



GÁBOR VARGYAS BARK - CLOTH CLOTHING
OF THE BRU OF CENTRAL VIETNAM¹

It is a well-known fact that “before the invention or adoption of woven textiles, bark-cloth was used to clothe the human body in many, if not all, tropical regions of the world”.² Beaten bark-cloth or, to use the Polynesian-originated name, *tapa* – a term used in almost all European languages – is still widely known and worn in many parts of the world, instead of or in addition to woven textiles.³ Regions where bark-cloth is traditionally used include Oceania (primarily Polynesia, but parts of Melanesia as well) and insular Southeast Asia; Central America and the Amazon Basin in South America; and Uganda and the Congo Basin in Africa. Items from these regions have long been at the forefront of scholarly and artistic interest, and they are relatively well studied.⁴ By contrast, the history of bark-cloth in mainland Southeast Asia is far less well-known, despite the fact that – to the best of our present knowledge – the most ancient archaeological evidence of the use of bark-cloth (in the form of stone bark-cloth beaters) comes from the Pearl River Delta region of South China.⁵ The art of weaving spread throughout mainland Southeast Asia relatively early in history, and supplanted the more “archaic” bark-cloth almost completely. By the first half of the twentieth century, the use of bark-cloth in this part of the world – apart from a few rare ethnographic exceptions – had more or less died out, and at best lived on in the collective memory.⁶ Proof of this is also provided by the volume titled *Bark-cloth in Southeast Asia* (2006), edited by Michael Howard. Disregarding its introduction, the work features only one essay on mainland Southeast Asia:⁷ unlike the other studies in the book, which are based on recent ethnographic field work carried out in insular Southeast Asia, the chapter in question is largely a second-hand summary of assorted data, taken from Vietnamese publications, dealing with ethnic groups in highland Vietnam.⁸ Another study in the same volume, which details an

1 I would like to express my gratitude to the following people for the valuable assistance they gave me in writing this article: to Ildikó Bellér-Hann for obtaining and copying Ihle’s work (1939), which I was unable to access anywhere else; to Gérard Diffloth for providing a detailed outline of the “Katuic” language data pertaining to *Antiaris toxicaria*; to István Rácz for his help in the botanical identification of *amúng*; to Irén Ráczkevi and Péter Nemes for making the drawings and patterns used as illustrations; to Imre Szakszon for preparing the videograms; and to Borbála Száva for the advice she gave me in analysing the photographs and data.

2 Aragon 1990, 32 (1), 33. The term “*beaten* bark-cloth” illustrates the fact that these materials are not *woven* textiles. The process may vary in degree of complication according to the region where the material is made, but the basic steps are the same: the wood bark is stripped off the trunk and soaked in water, and then, similarly to paper-making, the fibres are pounded using wooden or stone beaters; the pieces of fibre are then felted into larger sheets. Depending on the thickness of the material, and on the level of workmanship, the bark-cloth may resemble paper, textile or sometimes (for example, among the Bru, see below) coarsely pressed felt or animal skin.

3 The word *tapa*, in the sense of “textile-like material made from beaten wood bark”, came into European languages in the wake of Captain Cook’s voyages to Polynesia. On Samoa and Tonga, the term originally meant the border portion of bark-cloth sheets; on Hawaii, there is a special type of *tapa* called *kapa*.

4 See, for example, Anati 2005; Bell 1985; Guillaut and Bataille-Benguigui 2009; Howard 2006a; Klein 2001; Kooijman 1963; Kooijman 1972; Kooijman 1988; Leonard and Terrell 1980; Mesenhöller 2014; Pole and Doyal 2004; Schienerl 1997, etc.

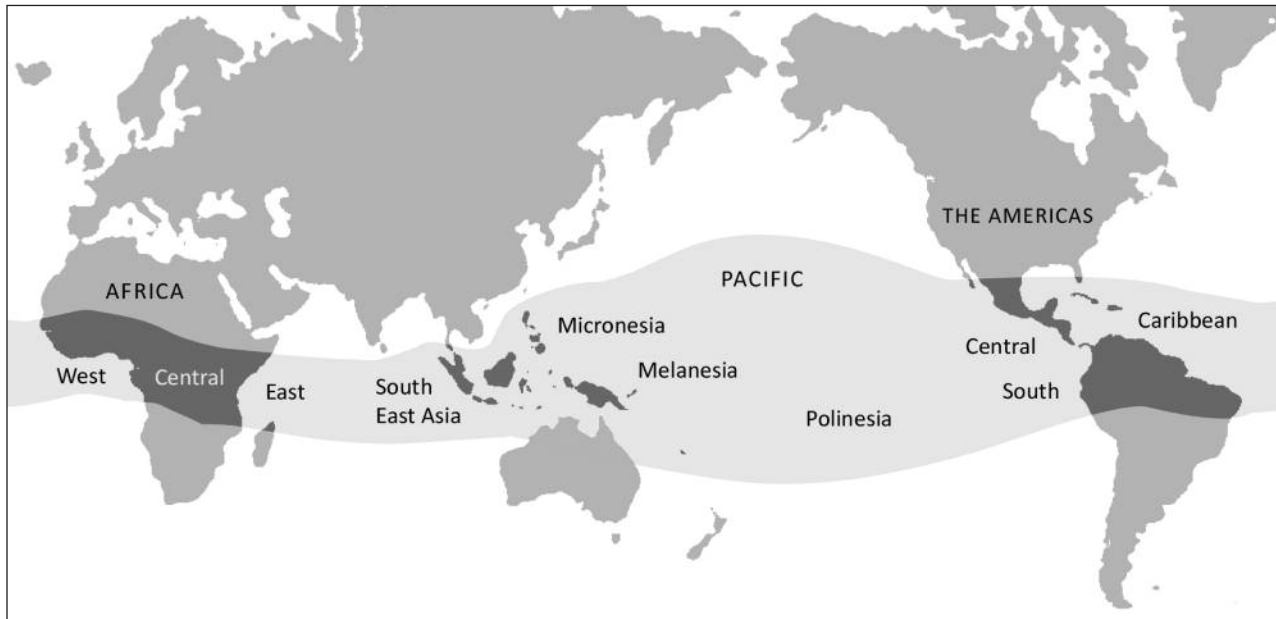

DISTRIBUTION OF TREE SPECIES USED IN THE PRODUCTION OF BARK-CLOTH. | AFTER POLE-DOYAL 2004. 19. COURTESY OF ROYAL ALBERT MEMORIAL MUSEUM & ART GALLERY AND EXETER CITY COUNCIL

interesting revival process on the island of Taiwan, demonstrates how far into the past bark-cloth technology has receded in certain areas: however, this reconstruction, carried out at the initiative of the local population, was “not based upon the living memory of past knowledge in terms of procedure and other associated labor involved but trial and error to recreate something in a new context for very different purposes”.⁹ This present study of mine may be regarded, in part, as a belated contribution to this landmark volume of essays: it describes a bark-cloth reconstruction from the highland region of Central Vietnam, which – unlike the aforementioned example from Taiwan – was based on still-living memory,¹⁰ and it contributes to redressing the balance between continental and maritime parts of Southeast Asia. As an aside, it is worth mentioning the unusual and paradoxical situation that *one* of the

references from Vietnamese literature cited by Luu Hung concerns the same ethnic group (the Bru), the same place, and even the same fieldwork and data collection as those I will expand upon below – only it omits my name and the circumstances of the collection, in addition to which it combines the data from this specific location and fieldwork with data taken from other written sources, which pertain to different ethnic groups!¹¹ I therefore seize this opportunity to clarify and supplement the information given there, and to provide a more complete picture of a clothing material and technique which are extremely important from a historical aspect, but which are no longer in use and have been virtually forgotten.

5 See Cameron 2006, 65–74; Howard 2006b, 1–64. The earliest known bark-cloth beaters are among the finds of the Xiantouling culture (4500–3700 BCE), from the Pearl River Delta.

6 Howard 2006b, 9.

7 Luu Hung 2006, 75–82.

8 Moreover, such data are often extremely superficial, taken from descriptions that generally apply to more than one ethnic group, and based on spoken information rather than participant observation.

9 Kun-Hui Ku 2006, 107.

10 Kun-Hui Ku (2006, 112) mentions another instance, in which the reconstruction was carried out at the request of the ethnographer-collector.

THE BRU. THE LOCATION AND CIRCUMSTANCES OF THE FIELDWORK

The Bru (known in Vietnamese as “*Vân Kiều*”),¹² whose language belongs to the Katuic group of the Mon-Khmer family, live in the forested hillside regions either side of the Truong Son (Annamite) mountain range separating Vietnam from Laos, close to the 17th parallel, which once divided North and South Vietnam. On the Vietnamese side, the Bru inhabit the provinces of Quang Trị and Quang Bình, mainly to the north of former Colonial Route 9, linking the coast (Đông Hà, Vietnam) to the Mekong Valley (Savannakhet, Laos). The area where their population is densest, around the capital of Hứng Hóa district, Khe Sanh (which achieved unwanted fame during the Vietnam War), was the location of my field work.¹³ The Bru are a typical “Proto-Indochinese” hilltribe. They are subsistence farmers, depending on slash-and-burn, shifting cultivation; their staple crop is “dry rice” (although in some places they also grow “wet rice”),¹⁴ which they supplement by growing maize, millet, sesame, tobacco and vegetables. They raise poultry, swine, goats, cattle and buffalo (of which goats and cattle are relatively recent adoptions from Europe). The wet climate precludes the production of cotton, so weaving is unknown, as are the skills of metalworking and pottery. Bru society is patrilineal, and upon marriage they practise patrilocal residence. The basic functional unit of social organisation is the *ntǎng*, which is a shallow patrilineage (or a segment of one) having a depth of 4-5 generations with a common ancestor: it is a named, exogamous, solidary, ritual group, headed by its eldest male member; leadership within the group is inherited according to the principle of seniority. The patrilineages themselves form parts of larger units, or clans (*mu*), although the latter no longer have any clear function.¹⁵ The political and landowning unit is the village. Political power is exercised by the village chief; his function is inherited according to the principle of seniority within the “indigenous” patrilineage; the functions of village chief and head of the patrilineage are therefore identical. The Bru religion is not a doctrinal one; it is based on the worship of various natural spirits (animism) and on ancestor cult. The ethnographic data collection took place at my initiative, following long and detailed preliminary discussions and preparations carried out during my previous fieldwork visits, in the villages of Xabai and then Đông Cho (Hứng Linh commune, Hứng Hóa district, Quang Trị province), between 25 November and 3 December 1989, with the collaboration of my Vietnamese colleague, Nguyễn Tất Thắng. Thanks to a favour extended to us by my host and friend in the village of Đông Cho, *mpɔaq* Toan, and by *mpɔaq* Tava from the village of Xabai, a tapa-making reconstruction took place at this time, which resulted in the production of two upper garments, “ponchos” (*ayǎh*)¹⁶ made from bark-cloth (*amúng*). The process was recorded in a series of photographs and

11 Nguyễn Tất Thắng 1991, 2, 62–65.

12 The Bru language has four distinct dialects, which are sometimes classified as independent languages: Vân Kiều, Khua, Tri and Mangkong. The first is only spoken in Vietnam, while the others are found mostly in Laos.

13 My field work lasted 18 months in total – spread out between 1985 and 1989 (2 months each in 1985 and 1986, 10 months in 1987–1988, and 4 months in 1989) – and was based in the twin villages of Cóc and Đông Cho, Hứng Linh commune, Hứng Hóa (Khe Sanh) district, in the province of Bình Trị Thiên (today Quang Trị).

14 “Dry rice” is the name given to any rice grown without irrigation in highland swidden fields. “Wet rice” is the term used for rice produced using flood irrigation methods on plains, in valleys or on hillside terraces.

15 According to some of my informants, in the past these clans were exogamous units. Furthermore, Vietnamese ethnographers state that the clans were “totemistic” – personally, however, I have no data regarding this matter, and I am convinced that “totemistic clans” do not exist among the Bru at all.



BRU BARK-CLOTH PONCHO. COLLECTED BY GÁBOR VARGYAS, 1989. MUSEUM OF ETHNOGRAPHY, BUDAPEST, INV. NO. 94.72.15.1.

also on a video lasting around an hour in total;¹⁷ one of the two ponchos made during the reconstruction is now in the Museum of Ethnography in Budapest, while the other (to the best of my knowledge) is part of the collection of the Vietnam Museum of Ethnology in Hanoi.¹⁸ Many members of the older generation still remembered that bark-cloth clothing was once worn by their community. They all concurred in stating that bark-cloth was the norm in their childhood, in the 1930s and 1940s, but when the wars came, the use of Vietnamese, Laotian and American textiles and clothing spread, and the older form was abandoned once and for all.¹⁹ At the time of my field work, between 1985 and 1989, such clothing was worn by nobody in the area I visited, which covered three communes; moreover, I was unable to find a single article of clothing preserved from the old days, although bark-cloth was recurrently mentioned whenever we talked about the past. The idea of reconstruction came about almost self-evidently. It must be stressed, however, that by that time, both bark-cloth itself (*amúng*) and the loincloths (*sarlai*) or “ponchos” (*ayǝǎh*) made from it were generally regarded as symbols of the past, and above all of backwardness and poverty.

CLOTHING MADE FROM BARK-CLOTH.

THE BARK-CLOTH PONCHO

Bark-cloth has long been used around the world for making a variety of items, from loincloths to ponchos that cover the entire upper body, from headwear to women’s skirts, from blankets to tablecloths or “carpets” spread on the ground; bark-cloth articles – like textiles – could be used in a range of situations, from the everyday to the ceremonial and sacral, and could also function as symbols of age, rank or status. In many areas (although not among the Bru!), certain items feature painted, appliqué or embroidered decorations; such decorated pieces often stand as outstanding exemplars of art in the cultures they originate from.

The Bru produced a limited number of types of clothing out of bark-cloth. From my own collection, I only know of data related to menswear: the bark-cloth poncho (*ayǝǎh*) and the loincloth (*sarlai*) were mentioned regularly when members of the Bru talked to me about the past, but I have no data of any kind to state that

16 In the French literature, Colani refers to this as *gilet* [waistcoat] (Colani 1936, 1, 197–280), while “jacket” is the term given in the volume edited by Howard (Howard 2006a); Ihle writes about “poncho-like upper garments” when speaking about the entire region (Ihle 1939). The term “tunic” also crops up, although the Roman tunic was rather an undergarment, and one of varying length, which could reach down to the waist or even as far as the ankle. I have chosen to use the term “poncho” for this best reflects its form and cut.

17 In view of the fact that the ethnographic data collection took place in the last few weeks of my (final) field work in 1989, the work remained slightly incomplete: I had no time to read through all my notes and to eliminate any inaccuracies, contradictions and omissions by making further enquiries: certain questions, regrettably, were left unanswered. I will make reference to these points in the relevant places.

18 The bark-cloth poncho I collected, which subsequently became part of the collection of the Museum of Ethnography, has the inventory number: 94.72.15.1; that of the two “loincloths” is: 94.72.15.2–3. I have placed the latter in inverted commas because these items are not true loincloths, but only imitations. See below. The museum’s collection includes a second bark-cloth poncho, also from the Bru, but from a more distant group in the vicinity of Vinh-linh, in the territory of the erstwhile Democratic Republic of Vietnam (North Vietnam), collected by the orientalist and philologist Benő Molnár in 1962. Its inventory number is: 68.84.15, and according to the definition made at the time by the collector, it is a “woman’s garment” made from bark-cloth in the 1950s. A picture of this item is included, but in the present study I have not presented a detailed examination of it. Even at first sight it is apparent that in terms of form, size and cut, it matches perfectly the bark-cloth poncho that I collected, although its raw material must have come from a different type of tree.

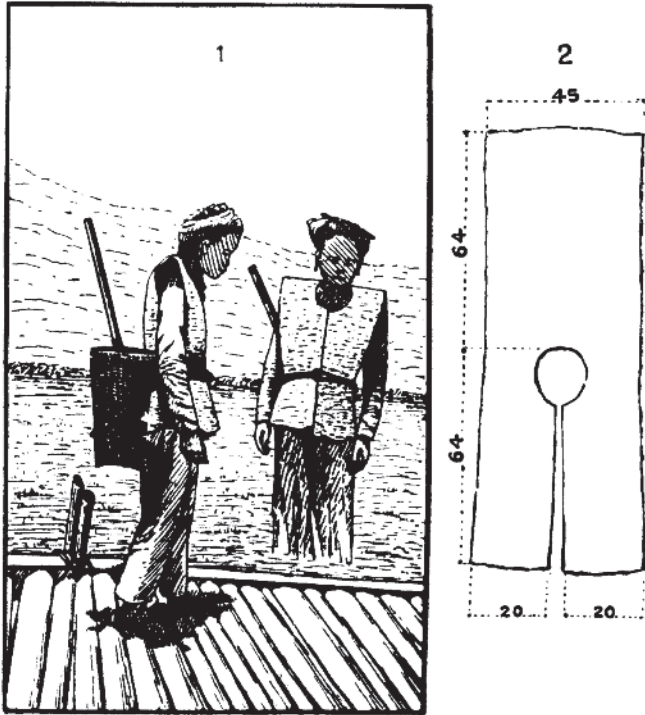

DRAWING AND PATTERN OF A PONCHO-LIKE BARK-CLOTH UPPER GARMENT. AFTER COLANI 1936, 240, FIGS. 51.1. AND 2, WITH THE CAPTION "BARK-CLOTH WAISTCOAT. KHA LƠ [ETHNIC GROUP] BA XUÔI VILLAGE, HƯỚNG HÓA DISTRICT, QUANG TRỊ PROVINCE". [BELOW THAT ARE FURTHER EXPLANATIONS: "1. ON THE LEFT IS THE VILLAGE "MAYOR" [!], ON THE TERRACE OF HIS HOUSE, DRESSED IN HIS WAISTCOAT, WITH A BASKET TIED TO HIS BELT AT THE WAIST. IN THE BACKGROUND IS THE SAME PERSON, FACE ON. 2. PICTURE OF THE FINISHED WAISTCOAT [VIEWED FROM ABOVE]." DRAWING BY MADELEINE COLANI, "BASED ON A PHOTOGRAPH". (SEE ALSO VARGYAS 2000, 72, FIG. 31)

blankets (*ayō*) or – apart from one uncertain reference – women's wrap skirts (*són*) were ever made from bark-cloth.²⁰ In the literature on the Bru, only one description of bark-cloth clothing can be found, written in 1936 by the art historian and ethnologist Madeleine Colani, the only scholar to make even a brief visit to the area

inhabited by the Bru. To quote from her: "We have in our possession a waistcoat made of wood-bark (figs. 51. 1 and 2); it comes from Annam [Central Vietnam], from the village of Ba Xuôi in Hướng Hóa huyện [district], Quang Trị province, inhabited by the Kha Lơ [Bru], a little evolved indigenous people. The material of our garment is coarse, light brown, slightly dirty, approximately 4 millimetres thick at most, covered with fibres that run across the garment, and bearing traces of beating. The waist-

coat, made of a single piece, without sleeves and without the least tailoring, is long, reaching around 64 centimetres in the middle of the back, along the spinal column; from one shoulder to the other, its width is 41 centimetres.²¹ Nothing is affixed to it, neither around the neck nor at the armholes. It is pleasantly warm. The Kha Lơ wear it when it is cold and on rainy days. They make this material themselves. Their other clothes are made from woven cotton; they do not make these cotton fabrics, but buy them from the Annamites [Vietnamese] at the large and very old market nearby, in Cam-lộ." In a footnote, she adds, "We saw one of these waistcoats being made: for the neck, a bowl

19 Kooijman (1963, 58, footnote 177) mentions a huge shortage of textiles in Indonesia during World War II. On Java, where bark-cloth had been displaced by textiles as early as the nineteenth century, to the extent that the older technique had been entirely forgotten, garments were substituted with other raw materials, such as pieces of rubber. The Toraja people of Sulawesi, however, were immediately able to revert to using their traditional *fuya* clothing, made from beaten bark-cloth. This example means that it is not inconceivable for the production of bark-cloth clothing to have undergone periodic revivals even among the hilltribes of Vietnam, such as the Bru, although I do not possess any data to substantiate this.

20 There is no way of knowing if this is the original state of affairs, or if erstwhile use was consigned to oblivion through more recent neglect or disuse.

21 The dimensions are in accordance with the average size of the Bru people. The poncho I collected has the following measurements: the thickness of the raw material varies between 3–9 mm, while the length is 70 cm and the width is 65 cm. The only relatively significant difference, therefore, is in the width, for reasons unknown.



BRU BARK-CLOTH PONCHO. COLLECTED BY BENŐ MOLNÁR, 1962. MUSEUM OF ETHNOGRAPHY, BUDAPEST, INV. NO. 68.84.15.

BRU MAN AND WOMAN - MAN WEARING A BARK-CLOTH PONCHO. PHOTOGRAPH BY MADELEINE COLANI, 1936?, WITH THE CAPTION "KHA" ["MOUNTAIN DWELLER"]. MUSÉE DE L'HOMME, PARIS, INV. NO. E. 34-236-69. | PUBLISHED IN: VARGYAS 2000, 73, FIG. 32. | ALTHOUGH THE MUSEUM CAPTION DOES NOT SPECIFY THE PLACE WHERE THE PHOTOGRAPH WAS TAKEN, IT WAS PROBABLY TAKEN IN THE VILLAGE OF BA XUÔI (HƯỚNG HÓA DISTRICT, QUANG TRỊ PROVINCE) | MUSÉE DU QUAI BRANLY, PARIS



BRU MEN IN BARK-CLOTH LOINCLOTHS. AFTER MALGALIVE AND RIVIÈRE 1902, 176, FIG. 45, WITH THE PHOTO CAPTION "KHA LEUNG" [ETHNIC GROUP]. (SEE ALSO VARGYAS 2000, 40, FIG. 14.)



of quite some size is placed on the bark, with its rim touching the middle [line] of the material; its line is traced with a piece of coal and then cut out using a knife, as is the slit at the front. The tailor uses neither thread nor scissors."²²

I will return later to the description, in particular the pattern; here, though, I must draw attention to an interesting fact concerning bark-cloth clothing: in the specialist literature, as in the discussions I had with the Bru, the poncho (*ayōǎh*) is a synonym (or symbol) of bark-cloth clothing: this is reported by Colani and also reflected in the Vietnamese literature,²³ while the method of making it was demonstrated to me – quite naturally and of their own accord, without being asked – by our Bru informant friends, in the course of the reconstruction! The "loincloths" which are now in the collection of the Museum of Ethnography, Budapest, but which are not part of the subject of the present study, were in fact by-products of the process of making

the ponchos, "supplementary" pieces assembled opportunely and hastily from the remnants cut off the ponchos, whose form and size were determined by the available, leftover raw material. It would seem that the loincloth, so familiar from the literature and from Vietnamese ethnic stereotypes, is not, after all, the most apt item for illustrating the essence of bark-cloth clothing! Furthermore, my informants generally referred to these ponchos as items of menswear, and this seems to be substantiated by a photograph taken by Colani, which shows a Bru man and woman standing side by side: the man is wearing a poncho and a loincloth, both made from bark-cloth, while the woman's upper body is naked above a trouser-type article of clothing, made of a thicker material which cannot be identified precisely (but which is definitely not bark-cloth!). (Also uncertain is the question of whether she is wearing actual trousers, or if they simply resemble trousers due to the special, uniquely Bru way of tying the wrap skirt.)²⁴

In view of the above, it is quite surprising to see that the original inventory note for the Bru bark-cloth poncho acquired by the Museum of Ethnography in 1962 states that the object is a "women's" garment.²⁵ We know from Ihle's comprehensive overview of Oceania and Southeast Asia²⁶ that "poncho-like garments with a head hole, side stitches and open armholes are relatively common" in Farther India.²⁷ "The items in question are almost always shirt-like or bag-like garments with a slit for the head, armholes on the sides,

²² Colani 1936, 239.

²³ Luu Hung (2006, 75), after a Vietnamese author, Mạc Đường (1963), writes not only about the Bru but generally about the groups speaking minor "Vietic" languages (Ruc, Arem, Sach), that "the Ruc, Arem, Sach, and Van Kieu [Bru] still wear a pullover shirt or 'poncho' made of bark-cloth up to present day".

²⁴ Borbála Száva drew my attention to a picture at the top of page 19 in the catalogue of the Vietnam Museum of Ethnology in Hanoi (Nguyễn Văn Huy 1997), which shows Bru women clearly wearing the loose wrap skirt as "trousers". I am also grateful to Borbála Száva for showing me a second parallel for wearing a skirt as trousers from the photo archive of the EFEO, which depicts a group of women

and more or less distinct joins for the sleeves”.²⁸ Such upper garments or ponchos, however, have generally survived only in relict areas; in his description, Ihle mentions Assamese (Naga), Khasi, Tibetan (Lepcha) and Kachin (Burmese) examples, but all of these were made from woven fabrics – in other words, he found no data on bark-cloth ponchos from mainland Southeast Asia! He does cite ethnographic examples of the latter from Polynesia, Micronesia (Ponape) and Indonesia (“Malayan Archipelago”), “while in Farther India it seems to belong to the past”.²⁹ The Bru bark-cloth described in detail below is therefore quite unique: as far as I am aware, apart from the two items we collected, there is no such object originating from continental Southeast Asia in any other museum in the world.³⁰ Moreover, there is no other description in the specialist literature that deals with the procedure for producing a bark-cloth poncho, not to mention its pattern or any detailed photographic or video documentation.

THE RAW MATERIAL

In Oceania, the barks of three types of tree are used for the production of tapa: the most commonly used is the paper mulberry (*Broussonetia papyrifera*), followed by species of wild breadfruit (*Artocarpus spp.*) and wild fig or banyan (*Ficus spp.*). Paper mulberry is a cultivated plant originating from Southeast China, while the others grow wild. In Southeast Asia, the situation is much more complex: even a single ethnic group may use a dozen types of tree. In his summary of Indonesia, Kooijman³¹ informs us that the Toraja of Sulawesi, for example, not only used the bark of *Broussonetia papyrifera*, *Artocarpus blumei* and *Ficus leucantatoma*, but also *Antiaris toxicaria (impo)*, *Trema amboinensis*, *Sloetia minahassae* and *Urostigma spp.* – all of these are wild trees of the forest. Aragon supplies similar data for the Tobaku, an Toraja group: besides *Broussonetia papyrifera*, *Artocarpus blumei* (wild breadfruit), and three species of *Ficus* (*F. infectoria*, *F. annulata*, *F. variegata*), *Antiaris toxicaria* was the main plant used as the raw material for tapa made by the Tobaku Aragon researched.³² With regard to Indonesia as a whole, based on 36 items of data identifiable with Latin names, Kooijman gives the following statistics: the most frequent are *Artocarpus* (7 mentions) and *Broussonetia papyrifera* (7 mentions) – the latter produces the finest quality material. Next in line is *Ficus* (6 mentions), and trailing far behind are *Trema amboinensis*, *Sloetia minahassae*, an *Urostigma sp.*

from an as-yet-unidentified “ethnic minority” of Laos, with no further information available. See: <http://collection.efeo.fr/web/app/collection/record/24886?vc=ePkH4LF7w6yelGA1iKGJhRIpKUQfM5CQIgKaH4AlZy64gIKHBQBs5i0N>.

²⁵ See footnote 18. Here I should note that I also have a single, severely doubtful item of data that refers to the possible existence of bark-cloth women’s wrap skirts: just one woman participating in the reconstruction, *mpiq* Toan, wife of *mpoaq* Toan, said, in an uncustomarily hesitant and uncertain tone, almost questioningly, and not very convincingly, that she thought that “poor” women sometimes wore such clothes (*sakát són*).

²⁶ Ihle 1939.

²⁷ Ibid. 1939, 101.

²⁸ Ibid. 1939, 96–97.

²⁹ Ibid. 1939, 102.

³⁰ Here, for the sake of simplicity, I have not included the other Bru bark-cloth poncho in the Museum of Ethnography, Budapest, which was collected by Benő Molnár. The present location of the item referenced by Colani is unknown.

³¹ Kooijman 1963, 56–57, 65.

³² Aragon 1990, 35.

and *Areca triandra* (1 mention each). The only cultivated plant among these is *Broussonetia papyrifera*, while all the others grow wild. Based on the enormous variety among wild, non-domesticated plants and the raw materials derived from them, fresh light may be cast on the questions of the existence of bark-cloth in Southeast Asia, its connection with Neolithic farmers, and its ancient origins – I will return to these questions at the end of this study.

The coarseness or smoothness of the raw material depends on the type of tree that is used: the softest material comes from *Broussonetia papyrifera*, as well as *Trema spp.* and *Artocarpus spp.* *Antiaris toxicaria*, by contrast, is known for producing thicker and coarser raw material;³³ what is more, the bark can only be collected from relatively young plants, because older trees contain toxins at an intensity that would pose a risk to those working with them.³⁴ As this type of tree has a lower adhesive content, it is not sticky enough to be handled using the same technique employed with *Broussonetia* and *Ficus* species, which involves felting together strips of bark taken from cut branches of different sizes. The tree is therefore cut down, and the bark is stripped off as a whole,³⁵ yielding a single piece of large, heavy, thick and coarse material that resembles textile or felt (and is not at all dissimilar to furry leather); it is subsequently cut to the desired size and shape. The fact that it comes from just one piece of material explains why the Bru poncho made from the bark-cloth of *Antiaris toxicaria* has such an elemental pattern, and why it is stitched (unusually for bark-cloth, which is customarily joined by felting).

In our case, we experienced difficulties with the botanical identification of the tree. The dried plant samples and material samples taken from the bark-cloth poncho could not be identified at the Natural History Museum in Budapest due to a lack of reference materials and suitable analytical equipment. Thanks to the kind efforts of botanist István Rácz,³⁶ however, we can state with a high degree of probability that the Bru *amúng* is *Antiaris toxicaria*; this is confirmed by data in the – not always completely reliable – Vietnamese literature. Both of the Vietnamese-Bru dictionaries,³⁷ for example, give the Vietnamese word for *amúng* as *cây sui*, which, according to virtually all the available Vietnamese sources, is *Antiaris toxicaria*. Nevertheless, our own experiences and a comment by Luu Hung advise caution when specifying precise

Latin names for botanical identification: “The Kinh people [Vietnamese] often call bark used as a substitute for woven cloth in general *sui* bark and assume that dress made of bark is made from *sui* bark. This is *Antiaris*, or *upas* in Malay.”³⁸ This clearly shows that the Vietnamese language uses the word *sui* as a general, collective term for all trees that are used for making bark-cloth – moreover, irrespectively of the fact that the local inhabitants, and even the Vietnamese-speaking majority, can identify numerous species of tree used as a source of bark-cloth, in dictionaries, the

33 This is supported by both Colani’s description and by the thickness of the poncho I collected, which fluctuates between 3–9 mm.

34 Aragon 1990, 36.

35 Ibid. 1990, 41; the Bru do the same, and according to Luu Hung (2006, 78), so do the Katu people.

36 István Rácz was able to identify the tree on the basis of the correspondence he conducted with his Vietnamese botanist colleague, and the photo sent to him from Vietnam, although the photo and the sample leaf did not match 100%.

37 Vương Hữu Lễ 1997; Hoàng Tuệ et al. 1986.

38 Luu Hung 2006, 76.

Latin name of *sui* tends to be given as *Antiaris toxicaria*, regardless of botanical reality! Luu Hung himself only differs from this tendency by mentioning – after having given detailed data on *Antiaris* – that several further types of tree also exist that are used for making bark-cloth. For these, however, he only provides the local names, and leaves out both the Vietnamese and the Latin equivalents!³⁹ In our case, the identification made by István Rác – though based on a photograph – enables us to accept, with high probability, that the tree known to the Bru as *amúng* is indeed *Antiaris toxicaria*. It remains for me to add that in Bru, the same word (*amúng*) can refer both to the tree and to the raw material produced from it.

FELLING TREES, BEATING THE BARK, AND PRODUCING THE RAW MATERIAL

The process was demonstrated in two stages. The first lasted a day and a half (25–26 November 1989) and consisted of cutting down the *amúng* tree and stripping the bark by beating it. The Bru are exceptionally knowledgeable about the forest and where exactly each type of raw material can be found: they know which part of the jungle plays home to different species of bamboo, ironwood, rattan, or *Antiaris toxicaria* – they fetch whatever they happen to need, as though popping into a “warehouse”. The trees – as is usual in such communities⁴⁰ – are owned communally by the village, as the land-owning unit; inhabitants of the village have the right to harvest them. In our case, the tree was in the territory belonging to the village of Xabai, so there was no

obstacle to the tree being cut down by *mpɔaq* Tava, a resident of the village. First, *mpɔaq* Tava spoke a brief prayer combined with a vow (*partoǎng*): he tied a knot onto one of the branches, and asked the tree spirit (*ylǎng*) to “stay in this knot” and to sprout the tree anew, thus ensuring the regrowth of the tree and continuation of the valuable material it provides.⁴¹ Measuring about 9–10 metres in length and



FROM SPEAKING THE VOW TO FELLING THE TREE
VIDEOGRAMS BY GÁBOR VARGYAS, 1989

³⁹ Six trees are mentioned without Latin names from the Ruch people, for example, a small group living in Quang Bìn province and speaking a “Vietic” language.

⁴⁰ See, for example, Aragon 1990, 37.

⁴¹ For a similar ceremony performed by the Tobaku, see Aragon 1990, 43.

with a perimeter of about 1 metre (30 cm diameter) close to the base of the trunk, the tree was cut down by axe (*achât*) and machete (*pria*) in just a few minutes, before being measured out – using outstretched arms, that is, a fathom – into two straight pieces from the middle, each a fathom long (roughly 170 cm),⁴² and devoid of branch stumps. After the trunk was cut up, these pieces were used as



CUTTING THE TRUNK INTO ONE-FATHOM LENGTHS
PHOTOGRAPH BY GÁBOR VARGYAS, 1989

⁴² The European fathom is generally between 180–190 cm. As the Bru are physically almost as diminutive as pygmies, I have estimated their fathom to be roughly 10 cm shorter than the European equivalent. Broadly similar measurements are also given by Aragon (1990, 37), who records branches 180 cm in length with diameters of 10–13 cm: in this case, the small diameter is explained by the fact that they are given not for *Antiaris toxicaria*, but for *Ficus spp.*, and the material of these trees (see above), by virtue of its greater stickiness, is felted together from thinner pieces and smaller strips.

⁴³ The beating began around 11 o'clock in the morning and continued until late afternoon. The next day, work resumed in the early hours and was completed by around 11 in the morning.

⁴⁴ Although I failed to ask explicitly during our enquiries, from the context it was clear that among the Bru the job of beating – like the entire process of making bark-cloth – is done by the men.

⁴⁵ *Aluang kuklôh kôq amúng*: “Wood + beat with a mortar using a vertical up-and-down movement + hit and knock perpendicularly + wood bark”, in other words, “bark-beating stick”. Unfortunately I did not witness the making of the bark-cloth beaters, as I was busy filming, so I do not know what type of wood they were made from, or who made them. I seem to remember collecting them together with the poncho, but somewhere along my way home they were misplaced.

the raw material for making the ponchos. Our friends lifted the two trunk pieces onto their shoulders and carried them back to the village, where work on beating the bark of the tree soon began – this part of the process lasted roughly a whole day, and was done in two phases.⁴³ The male population of the village of Xabai, a mix of young and old, joined in the beating. The people taking part changed from time to time, and their number increased slightly as the process went on, to 6–8 men; in addition there were other men, women and children just watching.⁴⁴

In the absence of any better tools, the beating was initially carried out using the thicker, blunter edge of the machete blade. Before an hour had passed, it transpired that this apparently quick and effective method was actually more damaging than useful: the iron was too hard, and was smashing the bark of the wood to pieces, rendering it too thin and ragged to be of lasting use. They soon began to use “traditional” wooden beaters instead. As this was a reconstruction, there was once more a certain amount of hesitancy and vacillation: at first, they used simple, cylindrical beaters, approximately 40 cm long, slightly narrowing at one end (*aluang kuklôh kôq amúng*), which were made on site.⁴⁵ Later, as the beating approached its



CARRYING THE TRUNK PIECES HOME | PHOTOGRAPH BY GÁBOR VARGYAS, 1989

BEATING THE WOOD BARK | VIDEOGRAMS BY GÁBOR VARGYAS, 1989



THE FIRST STAGE OF BEATING
PHOTOGRAPH BY GÁBOR VARGYAS, 1989



FROM BEATING THE TREE TO REMOVING THE BARK | PHOTOGRAPHS BY GÁBOR VARGYAS, 1989



conclusion, one of the older villagers, who had been watching the process, gave one of the participants a mallet-shaped beater, made from a forked piece of wood, which the old man had carved himself, but clearly from direct experience. The former implement was used to beat the trunk perpendicularly (*kôq*), while the latter was used at an oblique angle, removing the bark from the upheld trunk by hitting downwards along the trunk (*kang*). The fact that our bilingual informants had, together with the Bru name, already used the Vietnamese expression of *dùi dục* [= club-shaped mallet] to describe the previous type of bark-cloth beater (which was not shaped like a mallet!) is an indication that the shape is traditional, and not an innovation improvised there and then. This tool allowed the work to be carried out much more quickly and efficiently than with the previous ones.

What makes the Bru bark-cloth technique unique is that – unlike the Toraja⁴⁶ – they use the entire bark: in other words, they do not separate the bark into its outer, woodier part and its inner, softer part. From Aragon's description we know that the Tobaku score the bark with a knife and strip it off in one, before separating the outer and inner layers of the bark – only the inner part is used for beating. By contrast, the Bru do not strip the bark from the tree, but simply begin to beat the bark while it is still on the trunk – the trunk, cut to the right length, is initially laid flat on the ground, before being stood vertically after a short time. As a result of the beating, the outer and inner layers of the bark come away from the trunk together, already matted together to a certain extent. As the beating work progresses down the trunk, the loosened and separated bark material is pulled lower and lower. At the end of the beating process, the cylindrical piece of bark comes away completely, and turned "inside-out" like a bag, it can be pulled off the trunk in one piece. The woody outer bark is now largely pulverised and softened; any woody parts that remain after the beating and the subsequent process of soaking and drying are simply cut off with a knife. When the beating is finished, the "bark-cloth cylinder" is cut up using a knife and then spread out, resulting in a large, rectangular piece of material.

46 Aragon 1990. 41.



SOAKING

The beating is followed by soaking, which lasts one whole night.⁴⁷ The aim is not only to soften the material, but also to flush away any toxins from the bark-cloth. After we returned home from Xabai to Đông Cho in the late afternoon of 26 November, *mpoaq* Toan tied up the two pieces of bark-cloth with a twine and put them in the nearby river to soak overnight. The following morning (27 November) he removed them from the water, rinsed them thoroughly one by one, stamped on them and twisted them to tenderise them, and then hung them up to dry on a bamboo stick suspended horizontally above the veranda of his home. He then took a knife to cut off the harder, woodier parts – although he clearly made little effort to be thorough (perhaps as this was a reconstruction). The bark-cloth pieces needed several days to dry.



⁴⁷ According to Aragon (1990, 41), the Tobaku follow a similar procedure: the bark-cloth is soaked in water for just one night or day, and it is neither fermented nor boiled, unlike other types of bark. This also means that bark-cloth can be made most quickly – and *most simply* – from Antiaris. Conversely, Luu Hung contends (2006, 178) that in the process used by the Katu and the Bru (!), “A piece from an amung tree is cut and then soaked in water for about ten days.”



TAILORING AND SEWING THE PONCHO

The poncho was made on 3 December, back at our home base in the village of Đông Cho, once again with several active participants and quite a few – alternating – spectators.⁴⁸ The wife of *mpɔaŋ* Toan, *mpiq* Toan, also took part in the work, preparing the thread (*samũ*) for stitching the poncho from a type of forest liana (*yirong/yarong*); the tailoring, however, was exclusively men’s work, and *mpɔaŋ* Toan was aided in this by three other men.⁴⁹ First, the width of the poncho was measured out using the distance between

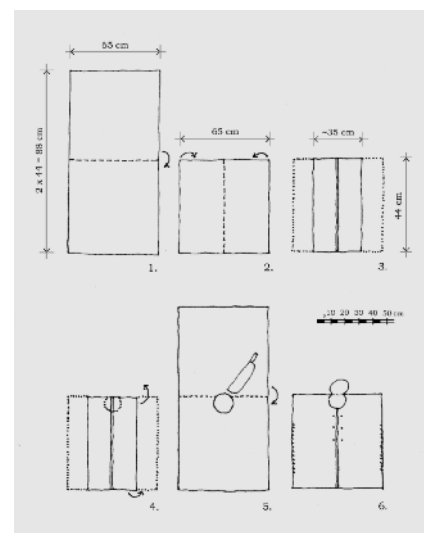
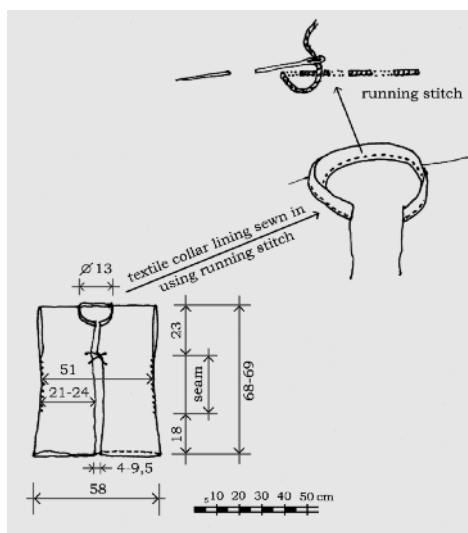
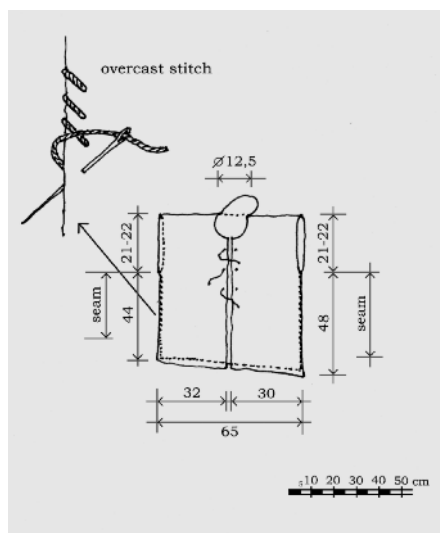

THE BARK-CLOTH PONCHO COLLECTED BY GÁBOR VARGYAS
 THE BARK-CLOTH PONCHO COLLECTED BY BENŐ MOLNÁR
 PATTERN OF A BRU BARK-CLOTH PONCHO | DRAWN BY IRÉN RÁCZKEVI

outstretched elbows, and then the material – cut straight and parallel a few centimetres from each elbow – was shaped (“evenly”) into a rectangular form using a machete.⁵⁰ The “tailoring” comprised the following steps: 1. The poncho was first folded in half lengthwise. 2–3. Both edges of the folded poncho were folded back (*kadap*) to the middle, but without them quite touching each other: this left a little space for the neck hole. 4. A porcelain bowl (*tangan*) was placed where the neck hole would be, and its outline was marked out using a piece of coal. The rim of the bowl was aligned with the top edge of the folded poncho, meaning that the neck hole was not precisely at the geometric centre of the poncho. 5. The bark-cloth was cut around the coal-drawn outline, but not completely, because 6. its upper part was left and then the material there was folded back. This served to strengthen the neck of the poncho.

⁴⁸ In light of the fact that I spent a year and a half in this village, my presence there was no longer regarded as a novelty – hence the relatively small number of people present.

⁴⁹ *Mpɔaŋ* Tava, from the village of Xabai, who had been one of the leading actors when the tree was cut down and the bark was beaten, did not take part in this stage of the reconstruction. In all likelihood, his presence had been needed when the tree was cut down because of issues of ownership. See above.

⁵⁰ *Ráiq amúng* = “cut + bark”; *táq tanlĩ* = “put + level”.



TAILORING THE PONCHO | VIDEOGRAMS AND PHOTO BY GÁBOR VARGYAS, 1989





TWISTING THE YARN AND THREADING THE NEEDLE | VIDEOGRAMS BY GÁBOR VARGYAS, 1989





51 A type of giant bamboo, which could not be identified more closely.

52 The method of making the "eye" of the needle is quite original: the opposite end to the sharpened point of the bamboo needle is softened by hitting it with the spine of a machete, and then two tines are twisted from it. The thread is then plaited together with the two tines.

7. The poncho was once again folded back to the middle from both sides: the point where the two sides met determined the line where the poncho would be slit down the front, resulting in openable flaps, like those on a jacket.

After the poncho was opened up, the only thing remaining was the sewing (*yīh amúng*): each of the two sides was sewn together using overcast stitching, leaving an unsewn section of roughly 20–25 cm at the top for the arms. Two types of material were used for sewing: on one side was the aforementioned thin, twisted thread made from forest liana (*sam̄ yirong/yarong*); the other side used a much stronger and coarser rattan yarn (*karái séaq*). The thread was twisted by the only female participant, *mpiq* Toan, and consisted of two stages: First she used a knife to lift up the outer bark of the liana, removed the soft, inner part, and then, using a rapid to-and-fro motion with the palm of her hand on her lower leg, she twisted it into small pieces of thread about 20 cm in length (*táq parlau*). She placed the pieces of thread between her toes, and when several dozen of them were ready, she twisted them together to form a longer thread, measuring several metres. The rattan "strips" were made by the men: *mpoag* Toan tore thin strips (*chēh karai séaq*) from a cylindrical rattan cane whose end had been hacked. The use of two different materials probably came about because of realisations made during the reconstruction: a piece of bamboo (*katang*)⁵¹ was sharpened to make a needle (*lanhô*),⁵² but sewing the thick bark-cloth with it proved problematic, as the needle broke several times and needed to be resharpened and hardened in hot embers; even then, the sewing process could only be completed by pre-punching holes using a sharp iron awl, to make it easier to pass the needle through the material. On the other side of the poncho, however, the pointed, flexible strips of rattan were simply threaded back and forth through the similarly pre-punched holes. This change of material was probably decided upon in order to speed up the process; I consider it unlikely that bark-cloth ponchos would originally have been sewn together using such coarse rattan strips. The final stage of the sewing process involved making the "buttonholes": four holes were made in each of the two flaps at the front of the poncho, and these were "laced" together using the thread. When the poncho is worn, it is tied around the waist using another strip of rattan as a belt; to this is affixed the "waist-held basket" (*adū*), an essential accessory in the forest, into which the machete is usually placed.

CONCLUSIONS

This completed the process of making the Bru bark-cloth ponchos. At the end of the reconstruction, when two men, *mpɔaq* Lô and *achuaih* Bônlai, put on the ponchos and the loincloth imitations, so that we could photograph them and film them as they walked next to the house, the people who had gathered around to watch burst into derisive laughter. There could be no better illustration of what I mentioned at the beginning: namely, that bark-cloth clothing was by “now” (1989, the time of the fieldwork) seen as a symbol of the past, of backwardness and poverty.⁵³

Regardless of how the Bru of today look down on the “archaic” bark-cloth poncho, from the point of view of the ancient history of Southeast Asia, the history of technology and the history of costume, this reconstruction provided us with invaluable data about a raw material, technology and type of clothing that are no longer in use, but which have not yet receded into oblivion. In this final section of my study, I will briefly touch upon a few related questions.

One of the frequently recurring questions in the literature on archaeology and ancient history concerns the spatial and temporal relationship between the techniques of weaving and bark-cloth beating, and the ancestral homeland of bark-cloth technology. Howard, in summarising earlier data and opinions, states that the “[a]rchaological evidence points to the origins of Southeast Asian and Pacific bark-cloth in southeastern China more than 6000 years ago. It is associated with Austric speaking peoples, who initially lived along and to the south of the Yangtze River, the ancestors of the Tai, Mon-Khmer, and Hmong-Mien speaking peoples of mainland Southeast Asia and the Austronesian speaking peoples of insular Southeast Asia.”⁵⁴ Howard associates bark-cloth technology in mainland Southeast Asia with the Neolithic Austric migration out of South China, and in his view the use of bark-cloth spread as the peoples living south of the Yangtze wandered far and wide.⁵⁵

The foundations for this and similar grand theories rest on a single distinctive – albeit partly disputed⁵⁶ – type of object: the stone bark-cloth beater. In 1978, Bellwood wrote the following on this topic: “One of the most significant points about these barkcloth beaters is that they are generally found only in Island Southeast Asia and its closest mainland fringes, particularly in Austronesian speaking areas, while most of the mainland sites produce spindle whorls instead. This may be an early reflection of a strong Austronesian tradition of barkcloth rather than woven clothing, a tradition which is still of course of paramount importance in Oceania.”⁵⁷ Even though our knowledge has expanded in the decades since Bellwood’s book was published, and we now have archaeological evidence of stone bark-cloth beaters from all over mainland Southeast Asia (South China, Vietnam, Cambodia, Laos, Malaysia, Thailand, Taiwan, and even Madagascar and South America),⁵⁸ “at this point it is not possible to link the earliest known bark-cloth beaters with a particular [language]

⁵³ A returning theme when talking to Bru informants about the poverty of the “olden days” was that “people used to wear bark-cloth clothing”.

⁵⁴ Howard 2006b, 1.

⁵⁵ *Ibid.*, 2.

⁵⁶ See, for example, Cameron 2006, 66; Kun-Hui Ku 2006, 108–10. These stone tools may have been pottery tools or even sago beaters – the consensus among archaeologists today is that the beaters with a jagged surface, at least, are associated with bark-cloth technology.

⁵⁷ Bellwood 1978, 173.

⁵⁸ Cameron 2006, 66.

group, but it does appear that all of the peoples mentioned above [i.e. members of the four major language families located to the south and east of the Yangtze River – G. V.] shared a common heritage of bark-cloth production that diffused as they spread from their homeland in southeastern China.”⁵⁹ In Howard’s opinion, among “Daic” and Hmong groups, weaving supplanted bark-cloth “at a very early date”, and there is little data available to indicate that they ever made or used clothes made from bark-cloth. “The spread of weaving in northern mainland Southeast Asia appears to be associated in particular with speakers of Daic languages.”⁶⁰ At the same time, the greatest number of ethnographic examples of bark-cloth technology are known from Mon-Khmer peoples, and to a lesser extent from Tibeto-Burman groups. Further, beyond the questions of “when” and “how”, there is also the matter of the kind of lifestyle pursued by groups of people who used bark-cloth technology. Based on the ethnographic material available, the general view in the specialist literature tended to be that bark-cloth was primarily associated with hunter-gatherers or swidden cultivators. Howard, however –without any evidence of any kind – dismissed this as pure speculation, based, in his opinion, on the fact that this technology had survived more strongly among such populations. “In the past, however, bark-cloth was also commonly produced among more sedentary [!] agriculturists as well. In fact, it is quite likely that its production began among early agriculturists and was later adopted by their less sedentary neighbors.”⁶¹

As I am no archaeologist, it is not my intention to debate these questions in detail; I would merely like to make a few remarks in connection with these matters based on my own material, presented in this paper. First of all it is important to stress that the Bru have no knowledge of weaving, just as they are ignorant of pottery and ironworking. This, however, is not a sign or consequence of some “innate” backwardness: the climate of the highlands they inhabit, the watershed of the Vietnamese Cordillera (Trường Sơn), with its high rainfall and humidity, preclude the cultivation of cotton.⁶² This fact in itself actually accords with Howard’s opinion, that bark-cloth technology existed among Mon-Khmer peoples, and preceded weaving. To this day, the Bru purchase most of their textiles from the neighbouring “Daic” peoples who know how to weave, specifically the Lao. It is therefore not surprising, and may indeed be logical, that bark-cloth technology remained in use until a relatively late date.

As the Bru are swidden agriculturalists, like the vast majority of hilltribes living in the vicinity, it would have been difficult for them to adopt this technology from the more “sedentary” Viet or Lao peoples, among whom bark-cloth technology – if it ever existed – is not known at all, judging from the literature.

The conceptual confusion reflected in Howard’s statement above (the difference between “early”, “more sedentary” agriculturalists and “less sedentary” swidden cultivators) poses difficulties of interpretation. Who are the “early” agriculturalists, if not the hill peoples practising swidden cultivation, among them the Bru? What kind of agriculture was carried out by “early agriculturalists”? And what is meant by “less sedentary”? Even though the essence of shifting cultivation lies in the fact that cultivators move on from one field to the next as the

59 Howard 2006b, 2.

60 Ibid.

61 Ibid., 1–2.

62 This was their own answer to my question, and they also used this reason to explain why they are well-known growers of tobacco, which – unlike cotton – requires copious rainfall.

soil fertility of the former becomes depleted, the Bru – like other practitioners of slash-and-burn farming – live as much a sedentary way of life as any other agricultural society. The fields are rotated, not the villages! This hypothesis of Howard’s – which in any event has no evidence to support it – can therefore be readily discarded for failing the test of factuality. Another argument against the hypothesis is the fact that – as we have seen – the majority of tree species used for making bark-cloth are still not domesticated, but grow naturally in the wild. Apart from the sole exception of *Broussonetia papyrifera*, which originated in South China, and which can only have reached Oceania as a domesticated plant, the multitude of different tree species grow wild all over both mainland and insular Southeast Asia, and are used locally according to need, as they always have been. As we could see from Kooijman’s summary of Indonesia, the most commonly used tree is wild *Artocarpus* (12 cases), followed jointly in second place (with 7 cases each) by – also wild – *Antiaris toxicaria*, and the cultivated *Broussonetia*. Faced with such circumstances, it seems remarkably contradictory to associate bark-cloth technology with sedentary Neolithic agriculturalists, just as it would be spurious to assert that South China is the origin of the entire technology due to the South Chinese origin of *Broussonetia*! Why should the sole domesticated plant be accorded greater weight than all the different species of wild trees? It seems far more likely that bark-cloth technology was once well-known across a much broader area: everywhere, in fact, where the plants required for bark-cloth grew – for this reason there is no need to resort to the as-yet-incomplete Austric theory, nor to the idea of the technology spreading from the Yangtze River region. A third question, related to this issue, is the problem of bark-cloth beaters. Archaeologists – and Howard as well – are aware that, aside from stone bark-cloth beaters, wooden bark-cloth beaters, which have survived only in the rarest of archaeological finds, are exclusively used in the whole of Polynesia and a large part of Oceania; despite this, for some unfathomable reason, grand theories of the spread of bark-cloth technology are nevertheless founded on the basis of the presence or absence of such objects.⁶³ As we have seen in the case of the Bru, a situation which is supported by numerous additional ethnographic parallels, the presence of a stone bark-cloth beater is by no means the *sine qua non* of the existence of the technology. One aspect of the shape of Bru wooden bark-cloth beaters that is of particular importance and interest to us is the “mallet-like” tool produced “*ad hoc*” towards the end of the reconstruction, which – if I have correctly understood the archaeological typology and drawings, which I am not intimately familiar with – is similar to the stone bark-cloth beaters of the Philippines described and presented by Bellwood, which have a special “horned protuberance”; this type is also



⁶³ For Polynesian wooden bark-cloth beaters, see Kooijman 1972 and 1988. The oldest wooden bark-cloth beater unearthed by archaeologists in Oceania was found in the Society Islands, and is dated to the ninth–thirteenth century CE (See Howard 2006b, 1).

presented by Cameron, who notes that they “are not widely distributed throughout Southeast Asia but appear to be confined to Taiwan and Insular Southeast Asia.”⁶⁴ The function of this “mallet” part – as I have already argued – is to enable the bark to be “beaten off/stripped off” in one piece from *Antiaris*. If the similarity of form proves correct, which – in my capacity as a non-archaeologist – I merely propose



as a question, this could have significant consequences. In view of the fact that, to the best of my knowledge, *Antiaris* is the only species of tree whose bark is stripped off in one piece, whereas other raw materials – due to their greater adhesive content – are felted together from smaller pieces, meaning that stripping them of their bark is not particularly problematic, the question may arise of whether this type of tool could be specifically related to working with *Antiaris*. If such a question were to stand its ground, then this could imply that different shapes of bark-cloth beaters could be related to different types of raw material – which would explain the

as-yet unresolved mystery of why there is such diversity in the shapes of bark-cloth beaters.

This question is also justified by the fact that, from the literature alone, it would seem that *Antiaris* is the *simplest* type of bark-cloth technology, involving the least amount of work, time and effort! Its importance is demonstrated by the fact that it is one of the most frequently used raw materials; it is thick and coarse, durable enough to withstand the physical demands of everyday work in the forest;⁶⁵ it is for this reason that clothes made from this material are usually undecorated, and never decorated by the Bru.

⁶⁴ See Bellwood 1978, 174, fig. 7.16./ type c. For the same (but drawn differently), see Cameron 2006, 66, fig. 2.1./ type II. Cameron 2006, 67.

⁶⁵ According to the Bru, they regularly wore the bark-cloth poncho when venturing into the forest. Besides keeping them warm and dry, the poncho also protected them from the scratches and other minor injuries that are almost unavoidable when walking through the undergrowth.

⁶⁶ G. Diffloth, e-mail, 20 February 2016.

Another source of bafflement when comprehensive archaeological theories about large geographical areas are formulated is how, in a matter of such ethnogenetic importance as beaten bark-cloth technology, it could be possible to proceed without taking into account any linguistic or lan-

guage-historical data. Whereas reconstructions concerning the ancestral home of Austronesian people have relied on the evidence of the Proto-Austronesian lexis ever since Heine-Geldern's study of 1937, it is striking that Howard fails to call upon the help of linguistics when outlining the hypothetical migrations of the Mon-Khmer and other language groups, or the history of bark-cloth technology. Yet, if we were to perform an overview of Mon-Khmer languages, the names of a tree or trees used as raw material for bark-cloth, for instance, may speak volumes: if the same linguistic stem could be established among distantly related languages, that might indicate common and ancient cultural assets. It was for this reason that I contacted the Mon-Khmer linguistic historian, Gérard Diffloth. I will quote from his kind reply: "A quick answer to your question about the Bru name for bark-cloth and *Antiaris toxicaria* is that there is a cognate word in Pacoh, with the same sound and meaning as in Bru, and there is a further cognate in Yiir (a closely related Katuic language called "In" in Lao): /mǎŋ/ "bark-cloth, *Antiaris tox.*" but this is all I have found so far; not very exciting, unfortunately, because Pacoh and Yiir are very closely related to Bru. Otherwise, there are of course several words in other Austroasiatic languages for these two notions, but not cognates. Quite meager, I am afraid; but still, the Yiir monosyllabic word suggests that the /ʔa-/ onset in the Bru and Pacoh names is historically a kind of Article, commonly found in Katuic Nouns; and then the /m-/ initial might suggest that this was at one point an -m- infix in a word that would have lost its initial consonant, but at this stage this would be a little gratuitous, unless that supposedly lost consonant could be recovered."⁶⁶ Although even this impeccably detailed linguistic-historical response is unfortunately unable to resolve the question raised, it does seem certain that several words exist in Mon-Khmer languages for the raw material of bark-cloth; any outline of the history of bark-cloth technology should therefore take account of linguistic reconstructions that encompass several language families (Mon-Khmer, Tibeto-Burman, Hmong-Mien, and "Daic").









APPENDIX



MAP OF SOUTHEAST ASIA SHOWING THE DISTRIBUTION OF THE ETHNIC GROUPS DESCRIBED IN THIS BOOK

