

## A Review of Thermoelectric Energy Harvester and Its Power Management Approach in Electronic Applications

Law Choon Chuan, Herman Wahid\*, Herlina Abdul Rahim, Ruzairi Abdul Rahim

Faculty of Electrical Engineering, Universiti Teknologi Malaysia, 81310 UTM Johor Bahru, Johor, Malaysia

\*Corresponding author: herman@fke.utm.my

### Article history

Received :April 2015

Received in revised form :

July 2015

Accepted :December 2015

### Graphical abstract

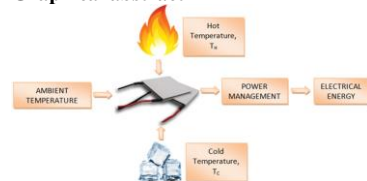

### Abstract

Thermoelectric energy (or power) harvester is a kind of renewable energy approach that extracts waste heat from targeted device or object to generate electrical power. It is an advance technology widespread among researchers for decades. By having plenty of promising advantages, the thermo-electric power harvester is being developed in types of feasible interfaces. This review paper focused on research had been done relating to thermo-electric power harvester, in the macro scale and mainly in the micro scale of power harvester. Several designs of thermo-electric technologies will be further discussed in this paper. This paper reveals the viability of thermo-electric power harvester in sustaining electric supply for micro-electronics applications. Eventually, some add-on is being proposed at the last part of the paper.

**Keywords:** Thermo-electric; energy harvester; power harvester; micro-scale; power management system

© 2015 Penerbit UTM Press. All rights reserved.

## 1.0 INTRODUCTION

Energy harvesting had been an imperative way of sustaining energy requirements these days. In order to remove finite life time of battery supplies, a self-sustain system needs to be introduced. Energy harvesting technologies overcomes the finite life time of battery supplies while reduce the dependent of coal and oil burning in power generations.

Energy harvesting system is classified into two types, macro energy harvesting and micro harvesting system. Macro energy harvesting system applies in large system to reduce needs for fuel and coal in energy generation. For micro energy harvesting system, it is targeted for low power device to sustain the power of device while trying to eliminate the use of battery in the system.

Among all energy harvesting resources, heat is described as one of the resource that is permanently available. An energy harvesting system that uses heat as source of conversion is called Thermo-electric Power Harvester. From the word of thermo-electric, it describes the relationship between thermal and electrical identities. As thermoelectric energy harvester depends on temperature fluctuation, heat can be converted into electrical energy using a solid state device called thermo-electric generator (TEG). TEG can be considered as popular among other energy harvesting resource due to its concise design. A simple block diagram of thermo-electric power harvester is illustrated in Figure 1. By having a simple design with permanent availability of resource, energy harvesting studies can be more straight forward and efficient. There is an extra token for this system where no moving parts are involved in the system design. This means that a

thermo-electric power harvester is effective in achieving cost effective in both modeling and maintenance sector.

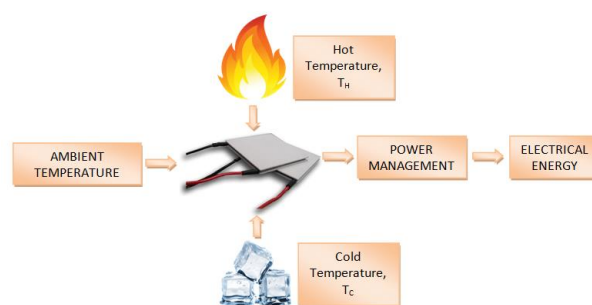

**Figure 1** Basic thermoelectric function block

Though, there are disadvantages in this thermoelectric energy harvester system where its energy conversion efficiency is low as compared to other types of energy harvester. However, the energy harvester systems from other sources such as wind and solar are much dependent on the availability of the source that is not constantly available and will directly affect the efficiency of the energy conversion. For hydro energy harvester, a specific water pressure is required in order to generate a specific rating of power, thus a small scaled high pressure hydro system is difficult to be done. A comparison table is made to compare the feasibility

of energy harvester in micro-scaled electronic applications as listed in Table 1. It is shown that heat based energy harvesting is more suitable with high availability of temperature in daily surrounding.

**Table 1** Energy harvester comparison table

Types	Source Availability	Energy Conversion Efficiency	Feasibility on Micro-scale Application
Wind	Depend on weather	Varies depending on source	Not suitable as wind speed is not constant
Heat	Always available e.g. on human body temperature	Low	Considerable with power management circuit under specific temperature range
Solar	Maximum six hours peak irradiance daily	Maximum during peak irradiance	Considerable with charge controller
Hydro	Available when there is high pressure water source	Conversion depending on water pressure	Considerable only with specific flow rate of water sources

Looking forward into efficiency of energy conversion, there are more to be discussed as many models of thermoelectric power harvester had been revealed in the research studies. For macro energy harvesting, Davidson and Mo had mentioned that thermoelectric power harvester had been applied into aircraft system and results in approximately 20 mW power generations from fluctuation of 70°C [1]. The generated power is sufficient enough to power up communication protocol by enabling communication procedure with central base station with power ranged 1 to 180 mW. In the same work, it is mentioned that by modifying power management circuit, a prototype TGI-2000 thermoelectric power harvester chip from Marlow Industries Incorporation is designed to support temperature fluctuation from an aircraft within a short distance flight. The invention of the chip clarify that a power management is a criteria when TEG energy harvesting is involved. It is mentioned that efficiency of energy conversion improved from 14% to 36%. Figure 2 describes the simulation of thermoelectric power harvester in different parts of aircraft. The simulation output varies from 5.46 mW to 34.15 mW accordingly to the parts within an aircraft.

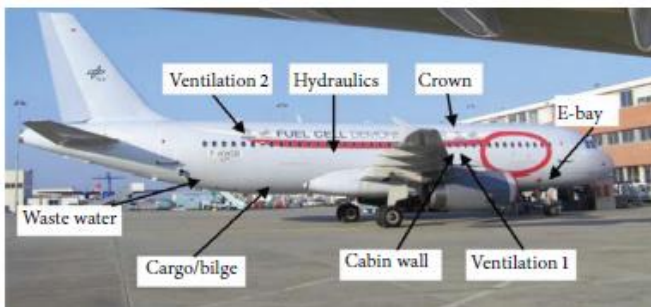

**Figure 2** Parts of aircraft with thermoelectric sensors [1]

There are applications where thermoelectric modules are being applied in dry cast storage. In [2], the author studies the possibility of placing a self-powered wireless sensor for nuclear dry cast storage. Since nuclear dry cast storage produces gamma

radiation, the studies of placing a wireless sensor without fading signal becomes tough. Spent nuclear fuel is being store in dry cast and it takes about five years before the fuel can be dispensed. Yet, before the spent fuel is disposed it has to be maintained under specific temperature for safety regulations. By working on all possible factors and modelling, the research was done by producing a self-powered wireless sensor that could last for 70 years for dry cast storage with a dc-dc converter. A sample of sensor positioning dry cast storage is presented in Figure 3 to give an idea on how the energy harvesting approach was done.

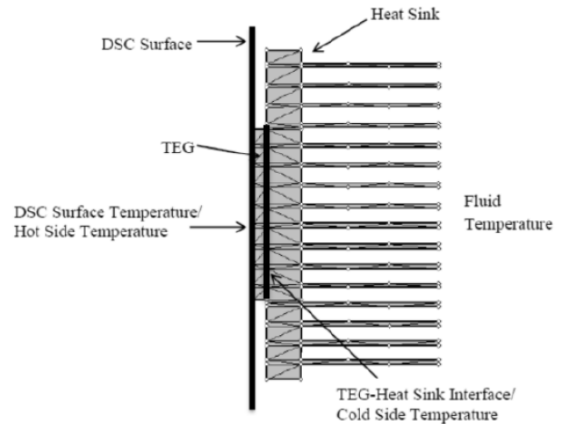

**Figure 3** TEG and heat sink positioning on dry cast storage surface [2]

Apart from aircraft and dry cast storage system, thermoelectric technologies also applied in hybrid energy harvester, the solar thermal dish. It is a high concentrated photovoltaic thermal electric module that could have plenty of functions. Concentrated heat can be used for evaporation process and energy conversion. In the studies, Xiao *et al.* [3] investigated the efficiency of conversion for the dish under wind condition. Initially, the energy conversion efficiency hits 20.6 percent with an operational temperature of 1280 K (approximately 1000 °C). With the present of wind blow, the efficiency drops to 19.0 percent at the same operating temperature. It is mentioned by the authors that wind blow does not affect efficiency of energy conversion while they proposed that solar thermal dish can be the least expensive solar concentrating system.

On the other hand, the micro scale thermoelectric power harvester received more popularity among researchers for its compendious design. According to Saez in [4], there are trends in technologies nowadays that the daily needs of electrical devices should be designed in smaller size with least power usage. The unremitting requirement for this technology trends made an imperative changes in technology development of thermoelectric power harvester. Wireless Sensor Networks (WSN), was a topic aimed to harvest energy from environment for low power electronics applications, the characteristic of thermoelectric sensor was also being included in the topic as human temperature was set as a source to harvest electrical energy. Several types of micro-scale application of thermoelectric power harvester mainly in human health monitoring will be reviewed in the paper.

## 2.0 OVERVIEW OF HEAT TO ELECTRICAL ENERGY CONVERSION USING THERMOELECTRIC

Energy conversion of heat to electrical involves three particular effects, described as Seebeck, Peltier effect and Thomson effect.

The theory of Seebeck effect explains the energy difference within an electrical circuit connected by two different types of materials exposed to two different temperatures. The theory was being discovered by T.J. Seebeck in 1821, as illustrated in Figure 4. Metal A is described as metal exposed to hot temperature while metal B is exposed to cold temperature. The variation of temperature caused potential differences within the circuit that can be measured using a voltmeter.

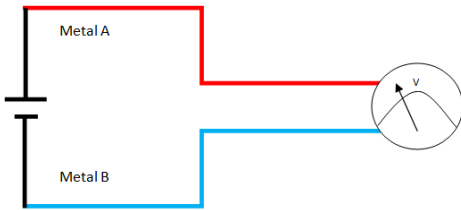

**Figure 4** Seebeck effect of metal A exposed to hot temperature (red) and metal B exposed to cold temperature (blue)

When the Seebeck theory was being applied and discovered, there was new statement mentioned that the flow of current within this doubled material circuit will harvest cool and hot temperature on the circuit itself. The effect of this case was called Peltier effect introduced by Jean Peltier right 13 years after Seebeck effect was discovered. Figure 5 shows the Peltier effect within a doubled material circuit.

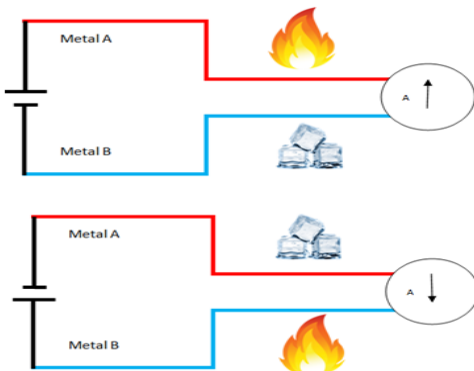
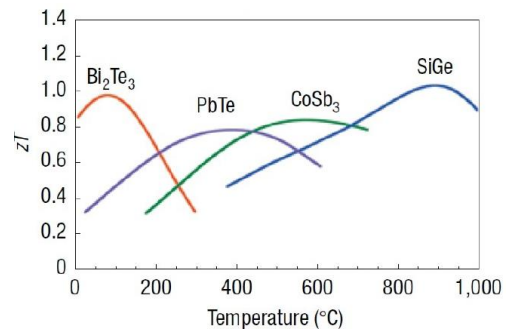

**Figure 5** Peltier effect in simple circuit

By creating a link in between Seebeck effect and Peltier effect, Thomson effect is revealed. This effect explains the generation of two sided heat from the flow of current along a conductor during a temperature gradient. These three effects conclude about the simple theory of heat to electrical energy conversion. Further into the theory will involves equation of process control that will result in characteristic and maximum output power generated.

As in energy conversion theory, the relative part that attracts most interest is the conversion efficiency of thermoelectric module. To maximize the conversion efficiency of thermoelectric module, factors that are needed to be considered are the conductivity of heat, conductivity of electric and rate of joule heating. These factors represented the base energy conversion circumstances where properties of material are important in determining efficiency of conversion. It is mentioned by Thomas [2] that relative low conductivity of heat is important to sustain large temperature gradient through material. Meanwhile, large conductivity of electric results in low rate of joule heating while large Seebeck coefficient produced high rates of voltage.

Optimizing Seebeck coefficient does not resolved the complexity of energy conversion efficiency as the three factors are vary by materials. In order to conclude all these factors, a new formulation had been introduced. The figure of merit, Z is a term that explains the efficiency of thermal energy conversion using the three factors stated above. Though, figure of merit over temperature, ZT is also varies on material. Practical conversion efficiency aims to achieve 1.0 but with variation of material, the conversion efficiency seemed fuzzy. A detailed figure of merit (ZT) for several types of material is shown in Figure 6. It explains the ZT over temperature for different kinds of temperature range.



**Figure 6** Figure of merit (ZT) over temperature for n-type of thermoelectric materials [5]

### ■3.0 EXAMPLES OF THERMOELECTRIC MICRO-SCALE APPLICATIONS

#### 3.1 Application of TEG in Implantable Medical Device

As rapid development had been done in micro-electronic devices, thermoelectric power harvester received more popularities in application as it provides a self-power sustaining idea to instruments so that charging and discharging does automatically. Meanwhile, thermoelectric energy harvester contributes to medical sectors as well in continuous monitoring that can be made to a patient and keep the patient secured.

As reported by Chen, implantable medical sensors had been proposed to be built in with thermoelectric energy harvester [5]. By understanding the power requirement for implantable sensors as in Figure 7, it is convincing that thermoelectric power harvester is feasible to be built in with these sensors. Since the sensors consumes from the range of 1  $\mu$ W up to 2 mW, it is considerable that thermoelectric power harvester could help in sustain operation of these sensors.

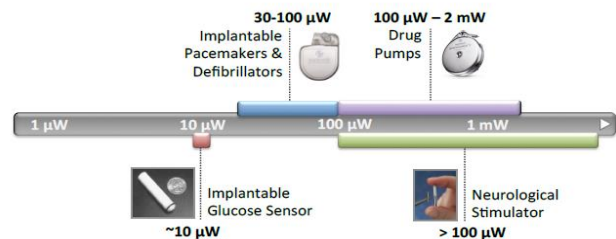

**Figure 7** Power requirement of implantable sensors [5]

Within the research, the author tries to fabricate a planar TEG using dispenser printing method. Within a few steps, the TEG can be fabricated on flexible and roll-able substrate for thermoelectric based technologies. By characterizing and synthesizing the material of TEG, the dispense printing can be

made on polymer material resulting a TEG that is flexible. The result of the flexible TEG can be viewed in Figure 8. The TEG is printed with double layer circuit that reduces total impedance on thermoelectric elements. Thus, efficiency of energy conversion can be improved.

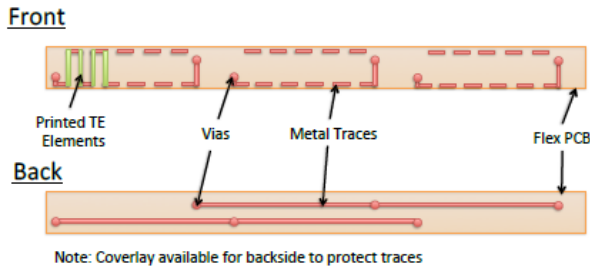

**Figure 8** Double layered TEG fabrication using dispenser printing method [5]

Taking consideration of the TEG produced, it is being considered that the TEG can be applied on fat layers by implanting techniques. Yet, there might be toxic element in TEG built material. A small dose of bismuth telluride ( $\text{Bi}_2\text{Te}_3$ ) does not cause effect in human organs. Large doses of  $\text{Bi}_2\text{Te}_3$  can cause toxicity to human organs especially kidney damage. In order to produce implantable thermoelectric based medical sensors, it is advised that the material for producing the TEG should be biocompatible so that it is safe to be use without harm.

**3.2 Application of TEG in Wearable Devices**

Having the same fabrication of TEG using dispenser printing method, there is research made for thermoelectric application on wearable devices. The typical thermoelectric wearable device is wrist watch which produced by Seiko Company. It is a watch that generates energy from the heat of human wrist to sustain watch function itself.

By aiming thermoregulation process from human body, heat will be an incessant source of energy for thermoelectric energy harvester. From the research done by Kim’s research team [6], a prototype of thermoelectric wearable device was produced. The device was produced and applied in fabric which is flexible and lightweight material. The fabrication of the thermoelectric fabric can be referred to Figure 9.

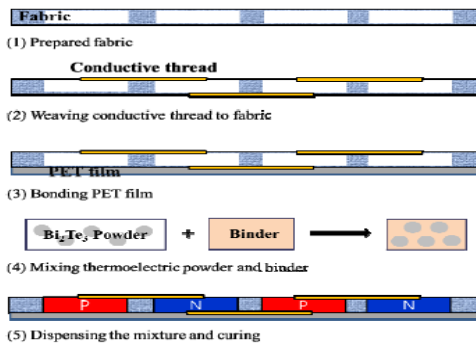

**Figure 9** Fabrication of thermoelectric fabric using dispenser printing [6]

The fabrication of fabric based thermoelectric module significantly attracts interest by its flexibility durability. The final

product of the fabrication is depicted in Figure 10 which shows the characteristic of the fabric and its design properties.

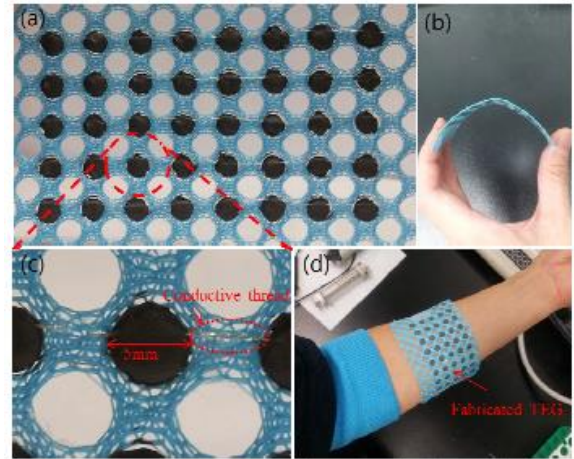

**Figure 10** (a) End product consisting of 20 thermoelectric device; (b) Elasticity of the fabric; (c) Zoom in view of the fabric materials; and (d) Prototype test on human arm [6]

The prototype was then being tested on human chest and result is as shown as in Table 2. The result obtained was not as good as in laboratory but it is referable due to the test was made on normal environment, a real time test with temperature fluctuations. The prototype is considered as success to prove the possibility of human wearable thermoelectric device and can be improved with better fabric material with less electrical resistance. By comparing available data from the table, it is shown that the greater temperature difference, the higher power generated. Though, ambient temperature to be as low as 5° C is not possible in Malaysia as the country does not have seasons change in a year. So, the best consideration is to have the first result with 7 °C temperature difference as a reference to ensure the next studies is applicable according to Malaysia weather.

**Table 2** Result of prototype testing on human chest [6]

Body Temperature (°C)	Ambient Temperature (°C)	Output Voltage (mV)	Output Power (nW)
32	25	2.1	15
32	5	7.3	178

**4.0 POWER MANAGEMENT APPROACHES FOR THERMOELECTRIC HARVESTING SYSTEM**

In order to produce a self-sustain system with thermoelectric module, power management is an important factor in the system design. Typical thermoelectric harvest millivolts on gradient of five degree Celcius of heat source, apparently it is not sufficient to sustain a system. So, proper power management approaches can be applied in order to manage the system that regulates with self-supplied functions.

Studies had been for made all over the world to verify the feasible of power management on low voltage source. There are few approaches that are available, among these approaches the most popular among researchers were step up DC-DC converter and charge pump. A step up DC-DC converter regulates input voltage by boost it up to rated voltage by the help of fast switching semiconductor. Throughout the advancing era in



technologies, this approach had been simplify into integrated circuits (IC) that user can connect pins on the IC and get appropriate output voltage without taking care of the element. A typical design of DC-DC step up converter can be seen in Figure 11 designed by Sarker et al. [7] on their research for 300mV startup voltage source. At the end of the study, the researchers managed to regulate 1.67V at the output of the DC-DC step up converter.

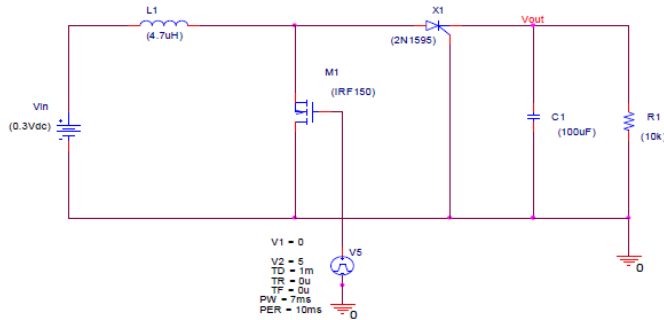

Figure 11 DC-DC step up converter for 300mV input voltage [7]

In order to reduce designs time, IC's are being produced to resolve the complexity of designing for electronics researchers. Linear Technologies company had produced an IC LT-3108 that is a simplify model of DC-DC step up converter that supports minimal voltage of 20mV with selectable output up to 5V. The typical application of this IC can be viewed in [8] which researched on power generation from body heat. A sample illustrated application of the IC is shown in Figure 12.

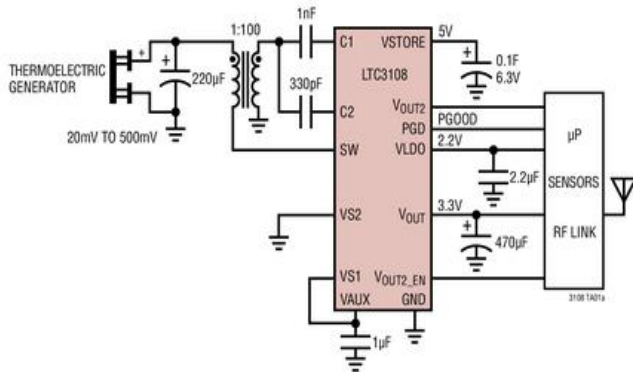

Figure 12 Sample application of LTC3108

Charge pump or voltage multiplier circuit is another approach to multiply voltage supply. The typical charge pump widely referred by researchers is Dickson charge pump. Dickson charge pump can be used to multiply supply voltage by adding the stage of the charge pump. On Anil and Sharma's paper [9], they reviewed several types of charge pump using charge switching transistor. By using a charge pump under fixed frequency, 1V can be generated to 15.97V. This shows the energy charging circuit is beneficial if it is applied to low voltage inputs. From Figure 13, the function of a multi-stage charge pump is described.

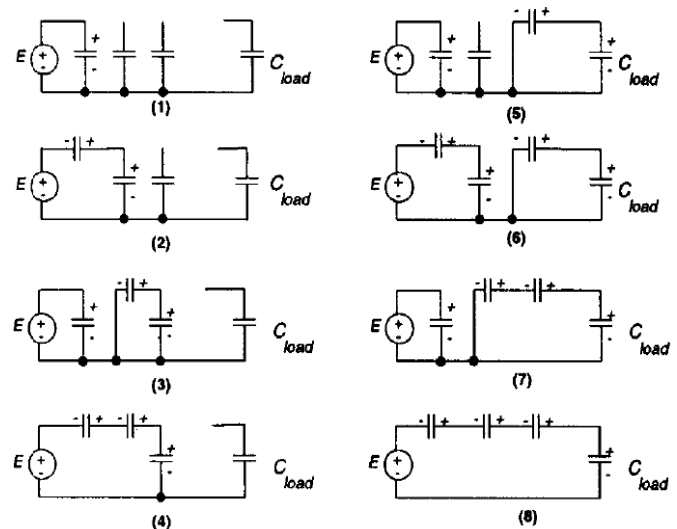

Figure 13 Operational of a multi-stage charge pump [10]

A comparison studies had been made to define the suitability of DC charge pump and DC boost converter by performances in [11]. It is a technical note to compare charge pump and boost converter by the specifications of design complexity, efficiency, size, flexibility, noise and ripple. In the comparison, DC charge pump score 4 out of 5 criteria. A detailed specification comparison is being summarize and recorded in Table 3. As shown in Table 3, specification of charge pump in terms of efficiency, noise and ripple is more convincing as power management tackles these points as in consideration for power conversion losses and total power conversion efficiency.

Table 3 Comparison of specification for charge pump and boost converter

Specification	Charge Pump	Boost Converter
Design Complexity	Simple.	Requires inductor and Schottky diode.
Efficiency	Up to 76%	59%
Size	Small	Slightly larger
Flexibility	Low, modification of output requires re-determination of nodes applied.	High, modification of output does not affect number of nodes applied.
Noise and Ripple	Less noise and ripple.	Noise and ripple due to voltage swing during switching process.

### 5.0 CONCLUSIONS AND FUTURE SUGGESTION ON THE THERMOELECTRIC ADVANCEMENTS

Thermoelectric had been taken broad interest among researchers and it shows big potential in developing this technology. Works in researching the characteristic of the thermoelectric module had been explored for the past decades and the significance of these researches can well be seen. However, it takes time for researchers to stabilize the output of energy harvested since the size requirement of hardware design is shrinking.

Based on research studies [1] to [4], it is well shown that TEG applications is widely applied in waste heat processing locations to generate power and power up small electronic devices. Within these studies, it is shown that each of the energy harvesting sequence is aided with a power management scheme in

order to stabilize generated energy. As mentioned in the studies, temperature differences must be high enough to ensure generate power is sufficient enough to sustain process of electronic circuits.

Considering studies in [5], [6] [14] and [17], the application of thermoelectric energy harvesting on medical devices and human daily needs is also an alternative way of generating power. Though, due to human body temperature is having small differences with ambient temperature, the generated power is only suitable in power up low power sensors as in Figure 7. In the way to improve the efficiency of thermoelectric sensors, fabrication process is encouraged to produce a TEG with less impedance on thermoelectric elements. In the way technologies are improving, TEG sensors are also well fabricated in small size. These sensors provided more studies to be adopted to enhance TEG energy conversion in human daily technologies.

Reviewing studies in [7], [8], [9], [10], [11], [24] and [25] the power management approach introduced is able to improve and stabilize energy conversion of TEG sensors. By comparing the charge pump and boost converter approaches, it is more convincing that charge pump is more suitable in manage and step up the power generated from TEG sensors. For output section, amplifiers can be applied to enhance the signal of output. In order to stabilize output fluctuations, filters can be applied while double stage voltage regulation can be made accordingly. For advanced control system, the Proportional-Integral-Derivative (PID) controller can be applied to achieve more accurate energy conversion while multi point power tracking (MPPT) can be applied to monitor power under specific nodes for power monitoring. For the primary stage of energy conversion stabilization, the method is not included this far.

As technologies had gone micro scale and devices are mostly designed handy and portable, there are possibility that thermoelectric energy harvester can be adopted into these technologies that enhance the portability of these devices. For example, health band for communication devices is widely attracting crowds to own for its function to calculate steps walk per day, heart rate, blood pressure etc. If thermoelectric technologies could be applied in these devices, then the wireless body sensor can be realized more practically. As a conclusion, a detailed study of the advancement of micro-scaled thermoelectric system configuration (i.e. in term of output efficiency) is preferred so that it can be applied in line with latest technologies contributing to human daily life.

### Acknowledgement

The authors would like to acknowledge the Flagship RG Grant from Universiti Teknologi Malaysia (UTM) with vote number Q.J130000.2423.02G12 for supporting this work.

### References

- [1] J. Davidson and C. Mo. 2014. Recent Advances in Energy Harvesting Technologies for Structural Health Monitoring Applications. *Smart Materials Research*.
- [2] T. A. Carstens. 2013. Thermoelectric Powered Wireless Sensor for Dry-Cask Storage. *ProQuest*, Thesis, University of Wisconsin-Madison.
- [3] L. Xiao, S. Y. Wu and Y. R. Li. 2012. Thermal-Electric Conversion Efficiency of the Dish/AMTEC Solar Thermal Power System in Wind Condition. *IEEE 2012 Third International Conference on Digital Manufacturing & Automation*.
- [4] M. L. M. Saez. 2009. Human Harvesting From Human Passive Power. Thesis, Universitat Politècnica de Catalunya.
- [5] A. Chen. 2011. Thermal Energy Harvesting with Thermoelectrics for Self-powered Sensors: With Applications to Implantable Medical Devices, Body Sensor Networks and Aging in Place. Thesis, University of California.
- [6] M. K. Kim, M. S. Kim, S. E. Jo, H. L. Kim, S. M. Lee and Y. J. Kim. 2013. Wearable Thermoelectric Generator for Human Clothing Applications. *IEEE Transducer 2013*. 16–20 June.
- [7] M. R. Sarker, S. H. Md Ali, M. Othman and S. Islam. 2012. Designing a Battery-Less Piezoelectric based Energy Harvesting Interface Circuit with 300mV Startup Voltage. *IOP Publishing in 3<sup>rd</sup> ISESCO International Workshop and Conference on Nanotechnology*.
- [8] C. J. Udalagama. 2010. Electrical Energy Generation From Body Heat. *IEEE ICSET*.
- [9] A. Anil and R. K. Sharma. 2012. A High Efficiency Charge Pump for Low Voltage Devices. *International Journal of VLSI design and Communications Systems (VLSICS)*. 3(3): June.
- [10] J. A. Starzyk, Y. W. Jian and F. Qiu. 2001. A DC-DC Charge Pump Design Based Voltage Doublers. *IEEE Transactions on Circuits and Systems-I: Fundamental Theory and Applications*. 48(3): March.
- [11] White LED Boost Converter V.S. Charge Pump. *Maxim Integrated*, Application Notes. 2005.
- [12] Z. H. Abdul Rahman, M. H. Md Khir, Z. A. Burhanudin, et al. 2013. CMOS based Thermal Energy Generator For Low Power Devices. *IJSER*. 4(5): May.
- [13] M. Kocoloski, C. Eger, R. McCarty, K. Hallinan and K. Kissock. 2007. Industrial Solid-State Energy Harvesting: Mechanisms and Examples. *ACEEE*.
- [14] P. D. Mitcheson. 2010. Energy Harvesting for Human Wearable and Implantable Bio-Sensors. In *32<sup>nd</sup> Annual International Conference of The IEEE EMBS*.
- [15] P. Dziurdzia. 2011. Modeling and Simulation of Thermoelectric Energy Harvesting Processes. *InTech Europe, Journal*. AGH University of Science and Technology, Cracow.
- [16] H. He. 2012. A Magnetomechanical Thermal Energy Harvester With A Reversible Liquid Interface. *ProQuest*, Thesis, University of California.
- [17] R. Kappel, W. Pachler, M. Auer and W. Pribly. 2013. Self-Sustaining Temperature Sensor in Body Area Networks. *IEEE*.
- [18] I. Boniche. 2010. Silicon-Micromachined Thermoelectric Generators for Power Generation from Hot Gas Streams. *ProQuest*, Thesis, University of Florida.
- [19] E. Brownell. 2013. Optimal Design of Thermoelectric Generators Embedded in a Thermal Resistance Network. *ProQuest*, Thesis, Tufts University.
- [20] A. S. Al-Merbaty. 2012. Thermal Analysis of Thermoelectric Power Generator; Including Thermal Stresses. *ProQuest*, Thesis, King Fahd University of Petroleum and Minerals.
- [21] M. Z. Yang, C. C. Wu, C. L. Dai and W. J. Tsai. 2013. Energy Harvesting Thermoelectric Generators Manufactured Using the Complementary Metal oxide Semiconductor Process. *ISSN Sensors 2013, Journal*.
- [22] E. Schwytter, W. Glatz, L. Durrer and C. Hierold. 2008. Flexible Micro Thermoelectric Generator Base on Electroplated  $\text{Bi}_{2-x}\text{Te}_{3-x}$ . *EDA/SDIP*.
- [23] T. M. M. A. I. Omer. 2014. Development of Solar Thermoelectric Generator. *European Scientific Journal*. 10(9): March.
- [24] V. Vitchev. 2006. Calculating Essential Charge-Pump Parameters. *Power Electronics Technology*, July.
- [25] Doms, P. Merken, C. V. Hoof and R. P. Mertens. 2009. Capacitive Power Management Circuits for Micro-power Thermoelectric Generators With a 1.4µA Controller. *IEEE Journal of Solid-State Circuits*. 44(10): October.
- [26] H. Jia, W. Ni and Y. Shi. 2007. A Novel DC-DC Charge Pump Circuit for Passive RFID Transponder. *IEEE Journal*.
- [27] W. C. Huang, J. C. Cheng and P. C. Liou. 2011. A Charge Pump Circuit by using Voltage-Doubler as Clock Scheme. *International Journal of Design, Analysis and Tools for Circuits and Systems*. 1(1): June.
- [28] J. A. Starzyk and Y. W. Jian. 2001. A DC-DC Charge Pump Based on Voltage Doublers. *Circuits and Systems I: Fundamental Theory and Applications*. *IEEE Transactions*. 48(3).
- [29] F. Pan and T. Samaddar. 2006. *Charge Pump Circuit Design*. McGraw-Hill Companies, Inc.
- [30] Th. Becker, M. Kluge, J. Schalk, T. Otterpohl and U. Hillerringmann. 2008. Power Management for Thermal Energy Harvesting in Aircrafts. *IEEE Sensors*.
- [31] R. Rahul and R. KartikArumuhaVelu. 2008. Power Management in Wireless Sensor Networks by enhancing Thermoelectric properties of their Circuitries. *International Conference on Advanced Computer Theory and Engineering*.
- [32] K. K. Win, S. Dasgupta and S. K. Panda. 2011. An Optimized MPPT Circuit for Thermoelectric Energy Harvester for Low Power Applications. *8<sup>th</sup> International Conferences on Power Electronics*. May 30 to June 3.

- [33] R. Grezard and J. Willemin. 2013. A Self-Starting Fully Intergrated Auto-Adaptive Converter for Battery-Less Thermal Energy Harvesting. *IEEE*.
- [34] G. Wu and X. Yu. 2013. System Design on Thermoelectric Energy Harvesting from Body Heat. *39<sup>th</sup> Annual Northeast Bioengineering Conference*.
- [35] M. Alhawari, B. Mohammad, H. Saleh and M. Ismail. 2013. A Survey of Thermal Energy Harvesting Techniques and Interface Circuitry. *IEEE*.
- [36] Q. Brogan, T. O'Connor and D. S. Ha. 2014. Solar and Thermal Energy Harvesting with a Wearable Jacket. *IEEE*.