

SURFACE SETTLEMENT INDUCED BY TUNNELING IN GREENFIELD CONDITION THROUGH PHYSICAL MODELLING

Aminaton Marto^a, Mohamad Hafeezi Abdullah^{a*}, Ahmad Mahir Makhtar^b, Hومان Sohæei^a, Choy Soon Tan^a

^aSoft Soil Eng. Research Group, Faculty of Civil Engineering,
^bIndustrialised Construction System Research Group, Innovative Engineering Research Alliance, Universiti Teknologi Malaysia, 81310 UTM Johor Bahru, Johor, Malaysia

Article history

Received

6 July 2015

Received in revised form

26 July 2015

Accepted

30 July 2015

*Corresponding author
feezi998@yahoo.com

Graphical abstract

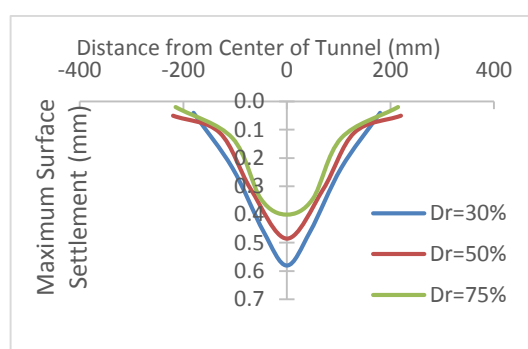
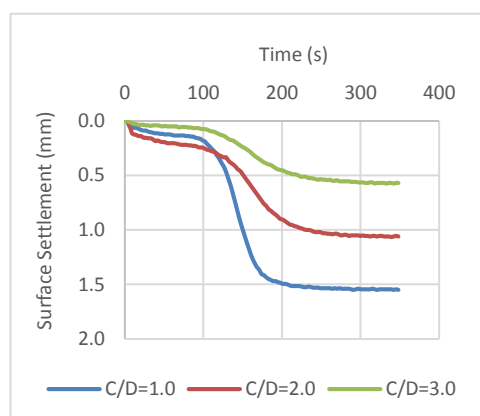

Abstract

Geotechnical conditions such as tunnel dimensions, tunneling method and soil type are few factors influencing the ground movement or disturbance. This paper presents the effect of tunnel cover to diameter ratio and relative density of sand on surface settlement induced by tunneling using physical modelling. The aluminum casing with outer diameter of 50 mm was used to model the tunnel shield. The size of the casing was 2 mm diameter larger than the tunnel lining. The tunnel excavation was done by pulling out the tunnel shield at constant speed with a mechanical pulley. The tested variables are cover to diameter ratio (1, 2 and 3) and relative density of sand (30%, 50% and 75%). The results demonstrated that the surface settlement decreased as the relative density increased. Also, as the relative density of sand increased, the overload factor at collapse increased. The surface settlement was at the highest when the cover to diameter ratio was 2. It can be concluded that in greenfield condition, the relative density and cover to diameter ratio affect the surface settlement.

Keywords: Relative density; cover to diameter ratio

Abstrak

Keadaan geoteknik seperti dimensi terowong, kaedah penerowongan dan jenis tanah adalah beberapa faktor yang mempengaruhi pergerakan tanah atau gangguan. Kertas ini membentangkan kesan nisbah penutup terowong kepada diameter dan ketumpatan relatif pasir ke atas enapan permukaan disebabkan oleh penerowongan menggunakan pemodelan fizikal. Sarung aluminium dengan diameter luar 50 mm digunakan untuk memodelkan perisai terowong. Saiz selongsong ialah 2 mm diameter lebih besar daripada lapisan terowong. Pengorekan terowong dilakukan dengan menarik keluar perisai terowong dengan kelajuan tetap menggunakan takal mekanikal. Pembolehubah yang dikaji adalah nisbah penutup kepada diameter (1, 2 dan 3) dan ketumpatan relatif pasir (30%, 50% dan 75%). Keputusan menunjukkan bahawa enapan permukaan mengurang apabila ketumpatan relatif berkurangan. Selain itu, apabila ketumpatan relative bertambah, faktor terlebih beban bertambah. Enapan permukaan adalah terbesar apabila nisbah penutup kepada diameter bernilai 2. Boleh disimpulkan bahawa dalam keadaan 'greenfield', ketumpatan relatif dan nisbah penutup kepada diameter memberi kesan kepada enapan permukaan.

Kata kunci: Ketumpatan relatif; nisbah penutup kepada diameter

© 2015 Penerbit UTM Press. All rights reserved

1.0 INTRODUCTION

Exploration and construction in underground space in other words tunneling is one of the most complex challenges in civil engineering. Two of the greatest issues in this 21st century are transportation and water, and by construction of bored tunnels is the only feasible means of providing such infrastructure while reducing the short term and long term impacts on both community and environment. However, one of the factors to be considered in tunnel construction is the settlement induced to the surface of the ground. Hence, the importance of having the knowledge on the deformation profile is crucial to ensure a safe and minimizing the impacts on surrounding existing environment.

The rapid growth of population in urban areas has enhance the increasing number of tunneling work which includes utilities construction, traffic flow and the necessity of underpinning structures. Hence, this indicates the importance of having the knowledge and estimating the surface settlement or failure mechanism in order to analyze its potential effect of affecting surrounding structures.

Shallow tunneling work is whereby the ratio of depth of tunnel to the tunnel diameter is less than 3. Different type of soils will results in different maximum surface settlement profile by taking into account the density of the soil and the rate of excavation to be carried out. This means that when the tunneling work is carried out in sand of different densities, the maximum surface settlement will also varies. Thus, by utilizing the physical modelling test, this study aimed to study the effect of depth to diameter ratio of tunnel and different relative density of sand used in order to produce a different profile of surface settlement.

2.0 PREVIOUS STUDY

The construction of underground space exploration which is tunneling has become very popular and demanding. This is due to the needs of the people that lived in urban areas usually that require alternative mode of transportation and also supply of utilities as the ground surface are already fully packed. Engineers must take note and acquire high knowledge on the pros and cons of tunneling construction. In urban areas, it is essential to protect existing adjacent structures and underground facilities from damage due to tunneling [1]. However, whenever construction of tunnel is being done, there will be surface settlement in both Greenfield and existing structures condition.

2.1 Surface Settlement Analysis

One of the most important issues in tunneling work is to understand and control the ground movement induced by tunneling. In other words, the surface settlement occur surrounding area of tunneling must be investigate as it may influence overlaying buildings and nearby utilities. Hence, various methods are used to predict the ground movement induced by tunneling which includes empirical

methods, analytical methods and physical modelling in tunneling. Empirically, several researchers [2], [3] have investigated the ground movements induced by tunneling and soil movements surrounding the tunnel.

2.1.1 Empirical Method

The surface settlement distribution can be determined empirically by using a normal probability Gaussian curve [2]. The properties of the normal probability function and its relationships to the dimensions of the tunnel are shown in Figure 1.

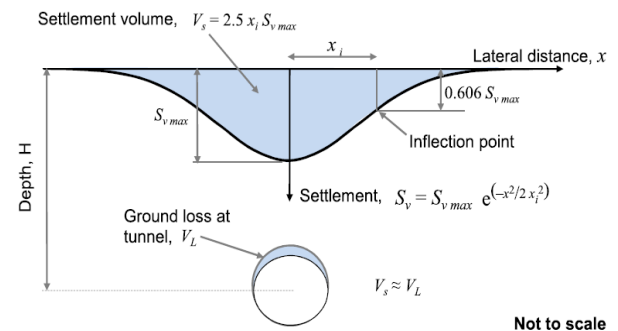

Figure 1 Properties of Gaussian functions used in prediction of surface settlement [2]

Basically, empirical solution that been developed is the main reference for researchers to develop more advance and detail solution. It helps in predicting the profile of the ground movement when tunnel is constructed. However, in order to adapt with this method, knowledge on expected ground loss volume, V_L , which is usually estimated as a percentage of the theoretical excavation volume. Table 1 summarized the factor that influence the estimation of the volume loss, include face loss, over excavation, pitching, ground disturbance, and tail void closure are the components that can cause the excavated volume to be larger than the theoretical tunnel volume.

Table 1 Relationship between volume loss (V_L), construction practice, and ground conditions [4]

Case	V_L (%)
Good practise in firm ground; tight control of surface pressure within closed face machine in slowly ravelling or squeezing ground	0.5
Usual practise with closed face machine in slowly ravelling or squeezing ground	1.0
Poor practise with closed face in poor ravelling ground	2.0
Poor practise with closed face machine in poor (fast ravelling) ground	3.0
Poor practise with little face control in running ground	4.0 or more

2.1.2 Analytical Method

The simplification of assumptions in terms of ground geometry, soil conditions, computing different case studies and definitions of boundary and initial condition are all the components when computing ground surface deformation by using analytical methods. When using analytical solutions, the volume loss computed is significantly reduced comparing with interpretations of volume loss that were based on empirical methods [5]. Moreover, the analytical solutions prove to be a very powerful tool in for describing ground displacements induced by different methods of tunneling excavation with different soil types. When using analytical method, the solution must satisfy the equilibrium equations, the strain compatibility equations, and the boundary conditions.

The analytical model [6] of shallow tunnel is shown in Figure 2. The model focused on short term ground movements of a shallow tunnel in a saturated ground with or without the application of air pressure during construction. The important feature includes: (a) circular cross-section with radius r_0 ; (b) plane strain conditions in a direction perpendicular to the cross-section of the tunnel; (c) frictionless interface between the ground and the liner; (d) depth to radius ratio larger than 1.5; (e) homogeneous and isotropic ground; (f) poroelastic behavior of the ground and elastic liner; (g) small thickness of the liner (i.e. liner thickness, $t \ll r_0$); and (h) permeability of the ground small enough such that no excess pore pressures dissipate during construction.

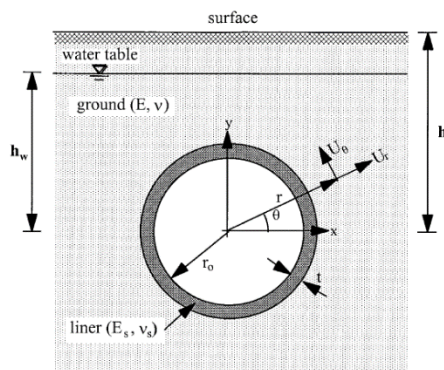

Figure 2 Analytical model of shallow tunnel [6]

2.2 Physical Modelling Technique to Predict Surface Settlement

One of the best methods for studies related to excavation of tunnels is by using physical modeling. Various modelling techniques have been developed by researchers [7],[8] all over the world. Physical modelling of tunnels also covers the ground deformation pattern around the tunnel as well as failure mechanisms.

In investigating the factor that influencing the ground-tunnel behavior, various laboratory models tests had been developed. Researchers investigate the ground movement and collapse mechanism induced by tunneling in different type of soils [7]. The model of tunnels usually modelled by either placing

soil around a pre-installed tube as a tunnel and controlling the supporting pressure or pre-cutting the tunnel opening and installing a lining system. In physical modelling, variety of techniques including trap door, rigid tube, pressurized air bags, polystyrene foam and organic solvent had been used by previous researchers.

Adachi *et al.* [9] conducted an axi-symmetric trap door experiments under 1g and centrifugal conditions. A tunnel was simulated using a circular trap door with a diameter of 5cm and can be lowered by a screw jack and electric motor. The interests are to measure the displacements and earth pressure surrounding the trap door placed in sand. Surface settlement is measured according to depth/tunnel diameter.

Chambon and Corte [10] conducted series of centrifuge tests to analyze the stability of the tunnel face in different types of soil. In order to represent the tunnel face, latex membrane was used. The transducer was utilized to record the face movements. The test was carried out by decreasing the pressure until failure.

3.0 METHODOLOGY

In this study, the shallow tunnel was modelled through physical model under single gravity (1g) using a box of 60 cm in length, 60 cm in width and 50 cm in height. The box was filled with sand obtained from Johor, Malaysia. The sand was allowed to dry under the sunlight for 24 hours prior to testing. The tunnel, constructed in circular shape which represents the Tunnel Boring Machine (TBM) technique, is made of aluminium tube with 48.8 mm inner diameter of tunnel and shielded by a tube of 50 mm outer diameter, which represents 5% of volume loss. The excavation rate of actual tunneling was scaled down and excavation was done by pulling out the tunnel shield at constant speed. This model was designed to stimulate the tunnel excavation process by controlling the ground volume loss induced by the process of pulling out the tunnel shield.

Two variable were considered in the physical model, which were the cover to diameter ratio, C/D (at three different ratio: 1, 2 and 3) and relative density of sand (at three different density: 30 %, 50 % and 75 %). Thus, altogether nine repetitive tests were conducted under the similar testing environment. The testing program was summarized in Table 2.

Table 2 Testing program considering various relative density and cover to diameter ratio

Relative Density	30 %	50 %	75 %
Cover to Diameter Ratio	1.0	1.0	1.0
	2.0	2.0	2.0
	3.0	3.0	3.0

Figure 3 shows the dimensions and the modelling approach used in the laboratory for the surface settlement prediction in greenfield condition as stated earlier. Figure 4 shows the details of the tunnel dimension and set-up of laboratory physical model. In

measuring the surface settlement, Linear Variable Differential Transducers (LVDT) were used. A rack containing four LVDTs was bolted onto the top of the modelling box to measure the vertical surface settlement.

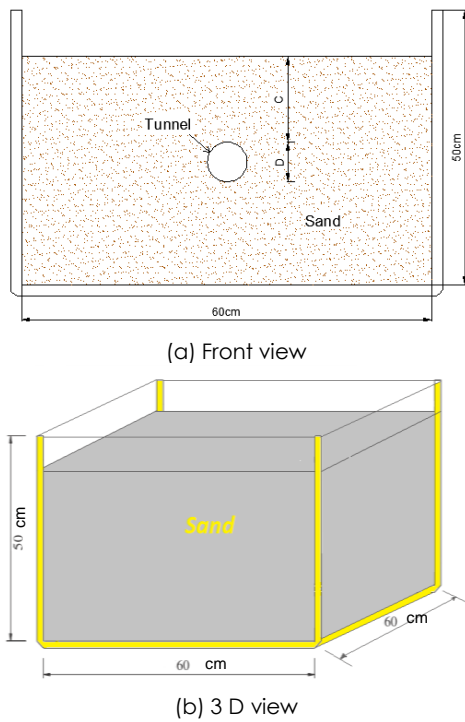
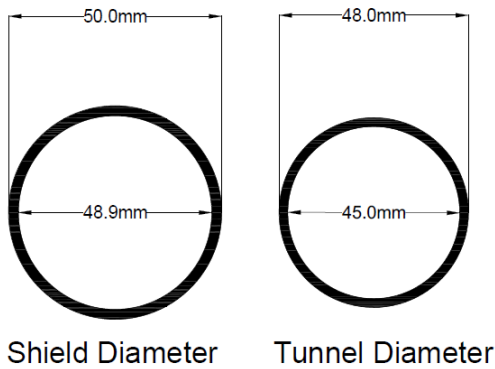

Figure 3 Test box model



(a) Tunnel details in modelling Test



(b) Physical model

Figure 4 Tunnel details and set-up of laboratory physical model

4.0 RESULTS AND DISCUSSION

4.1 Longitudinal Surface Settlement

The profiles of surface settlement at different relative density (30% represents loose sand; 50% represents medium dense sand and 75% represents dense sand) are shown in Figure 5. The graph was plotted by using the recorded value of LVDT located at the center axis to the tunnel center throughout the excavation process.

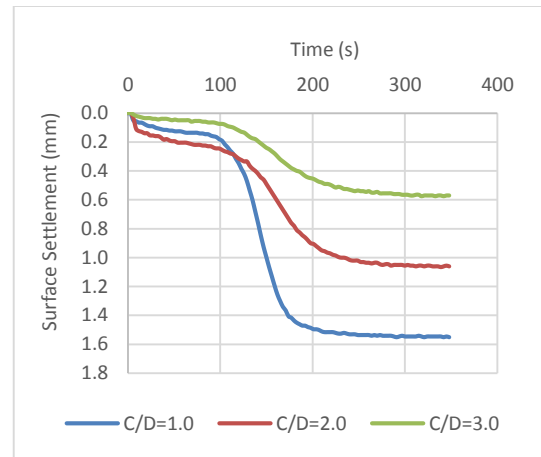

(a) Loose Sand ($D_r = 30\%$)

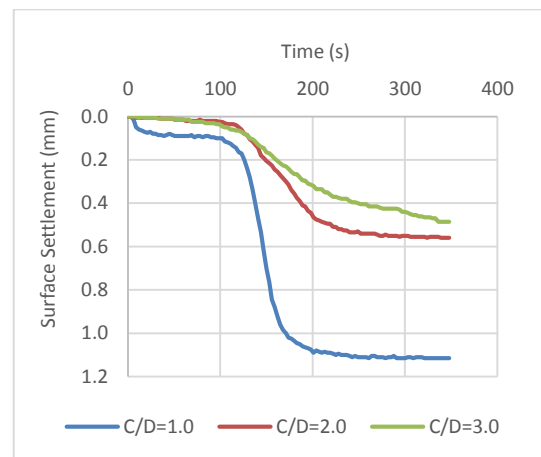

(b) Medium Dense Sand ($D_r = 50\%$)

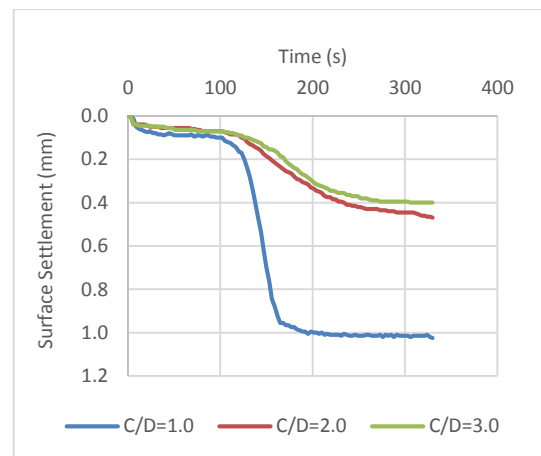

(c) Dense Sand ($D_r = 75\%$)

Figure 5 Surface settlements at different relative density

It can be seen from the Figure 5 that as the tunnels are excavated, the surface settlement increased steadily until reaching a point (critical point) beyond which the settlement dramatically increased. Generally, the critical point distance was further away in high dense sand than the loose sand. This is because the induced surface settlement increased dramatically due to the overload factor (OF) exceeded a critical value [11]. For a single tunneling work, there would be a point called overload factor at collapse (OF_c) that intersect the point. The importance of having this parameter is to help in installing supports from collapse in terms of stability of the tunneling work.

As shown in Figure 5, different C/D ratio resulted with different value of surface settlement induced. The surface settlement increased with respect to the time of construction. It can be observed that, for a particular density of sand almost the same point of OF_c was observed, although the C/D varies from 1.0 to 3.0. The OF_c was 120 sec, 130 sec and 140 sec for loose, medium dense and dense sand, respectively. However, the settlement between different C/D ratios clearly illustrated that when the C/D ratio increased, the longitudinal surface settlement induced by tunneling also increased.

4.2 Transverse Surface Settlement

The maximum surface settlement occurs at the location of excavation of tunnel carried out is known as transverse surface settlement. In order to obtain the measurement, the LVDT was set up vertically above the tunnel center. The results are shown in Figure 6. It can be seen that the maximum surface settlement occurs at the center of tunnel is due to ground loss, V_L attributable to soil that moved into the tunnel face [12]. For deeper tunnel (high C/D ratio), deeper trough and higher value of maximum surface settlement was observed. This is also true when the density of sand increased from loose sand to high density sand. The maximum surface settlement can be determined by using normal probability Gaussian curve [2]. The curve of maximum surface settlement shown in Figure 6 positively represents the shape of Gaussian curve by keeping the same size of the tunnel diameter.

4.3 Maximum Surface Settlement

The maximum surface settlement of nine different testing conditions was plotted in Figure 7. It demonstrates that the settlement decreased nonlinearly by increasing the tunnel depth. This effect was more effective when the relative density of soil was low (loose sand). In other words, at relative density of 30%, the result at C/D=1.0 shows the highest value of surface settlement (equal to 0.775 mm). In contrary, when the soil density changes to 75%, the surface settlement reduced. The smallest surface settlement observed was for C/D=3.0 where the amount of settlement were 0.29 mm and 0.2 mm for 30% and 75% relative density of sand, respectively. Table 3 shows the maximum values of surface settlement at C/D=1.0, 2.0 and 3.0 at different relative densities while Table 4 shows the

summary of maximum surface settlement, obtained during the physical modelling tests.

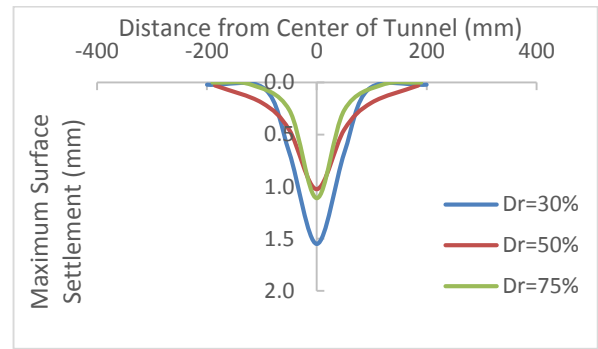

(a) C/D = 1.0

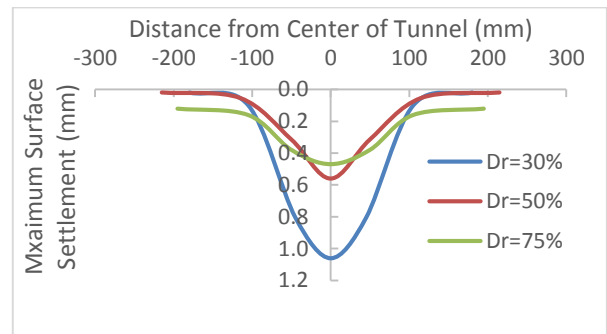

(b) C/D = 2.0

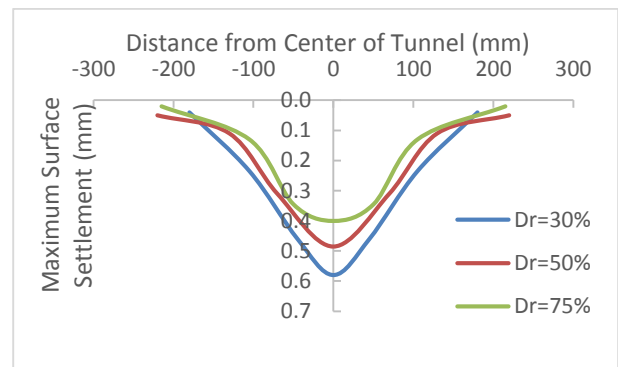

(c) C/D = 3.0

Figure 6 Maximum transverse and longitudinal surface settlement at different cover to diameter ratio

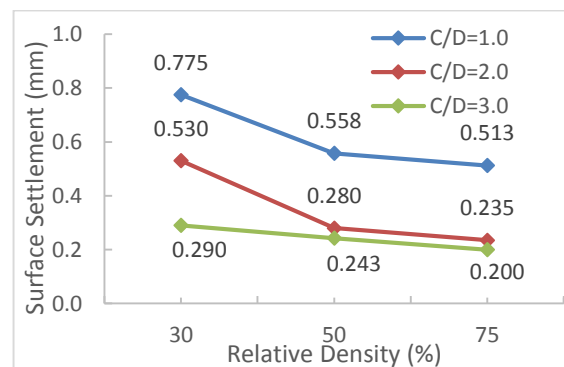

Figure 7 Summary of the maximum surface settlement

Table 3 Maximum transverse and longitudinal surface settlement at different relative density

Relative Density (%)	C/D=1.0		C/D=2.0		C/D=3.0	
	Transverse, S_{max} (mm)	Longitudinal, $0.5S_{max}$ (mm)	Transverse, S_{max} (mm)	Longitudinal, $0.5S_{max}$ (mm)	Transverse, S_{max} (mm)	Longitudinal, $0.5S_{max}$ (mm)
30	1.550	0.775	1.060	0.530	0.580	0.290
50	1.115	0.558	0.560	0.280	0.485	0.243
75	1.025	0.513	0.470	0.235	0.400	0.200

Table 4 Summary of maximum surface settlement, S_{max} (a) Relative Density, $D_r = 30\%$ (loose sand)

C/D=1.0		C/D=2.0		C/D=3.0	
Distance (mm)	S_{max} (mm)	Distance (mm)	S_{max} (mm)	Distance (mm)	S_{max} (mm)
-200	0.020	-180	0.020	-180	0.040
-95	0.060	-105	0.100	-105	0.235
-50	0.675	-45	0.805	-45	0.46
0	1.550	0	1.060	0	0.580
50	0.675	45	0.805	45	0.460
95	0.060	105	0.100	105	0.235
200	0.020	180	0.020	180	0.040

(b) Relative Density, $D_r = 50\%$ (medium dense sand)

C/D=1.0		C/D=2.0		C/D=3.0	
Distance (mm)	S_{max} (mm)	Distance (mm)	S_{max} (mm)	Distance (mm)	S_{max} (mm)
-185	0.030	-215	0.020	-220	0.050
-100	0.195	-115	0.055	-130	0.110
-50	0.455	-50	0.315	-70	0.310
0	1.115	0	0.560	0	0.485
50	0.455	50	0.315	70	0.310
100	0.195	115	0.055	130	0.110
185	0.030	215	0.020	220	0.050

(c) Relative Density, $D_r = 75\%$ (dense sand)

C/D=1.0		C/D=2.0		C/D=3.0	
Distance (mm)	S_{max} (mm)	Distance (mm)	S_{max} (mm)	Distance (mm)	S_{max} (mm)
-190	0.000	-195	0.120	-215	0.020
-120	0.020	-105	0.160	-105	0.130
-50	0.265	-50	0.380	-50	0.345
0	1.025	0	0.470	0	0.400
50	0.265	50	0.380	50	0.345
120	0.020	105	0.160	105	0.130
190	0.000	195	0.120	215	0.020

The difference on maximum surface settlement at relative density of 50% and 75% were calculated taking the maximum surface settlement at 30% relative density as the baseline. The percentage of differences between these relative densities were computed and shown in Table 5 for different C/D ratio.

Table 5 Percentage difference of S_{max}

C/D	Difference in S_{max} from 30% D_r	
	$D_r = 50\%$	$D_r = 75\%$
1.0	28	34
2.0	47	56
3.0	16	31

Figure 8 shows the percentage differences on S_{max} in $D_r=50\%$ and $D_r=75\%$ for C/D=1, 2 and 3 each with the results obtained at $D_r=30\%$ as the baseline. Generally, the percentage difference in dense sand was slightly higher than medium dense sand. At $D_r=50\%$, the percentage differences increased from 28% to 47% as the tunnel C/D ratio increased from 1 to 2. However, for C/D=3, the percentage difference reduced down to 16%. The pattern at $D_r=75\%$ was similar with $D_r=50\%$ but with larger percentage differences starting from 34% at C/D=1 that increased to 56% at C/D=2 and finally decreased to 31% for C/D=3.

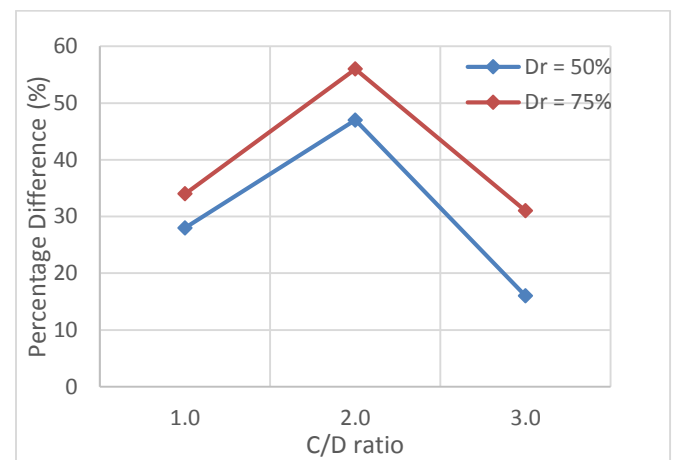
**Figure 8** Percentage differences on S_{max} with respect to $D_r = 30\%$

S_{max} at different depth of tunnel shows increased in the percentage differences from C/D=1 up to 2 but later resulting in lower percentage differences as the tunnel depth approaching C/D=3. For C/D=1 and 2, the tunnel depth were closer to the surface, resulting in higher surface settlement during tunneling work, hence causing the percentage differences to be higher. For C/D=3.0, the differences in maximum

surface settlement were lower at all relative densities, resulting with lower value of percentage differences.

5.0 CONCLUSION

From the physical modelling tests, the following conclusion can be drawn:

1. For shallow depth tunnel, the relative density of sand, D_r , plays more important role than the cover to diameter ratio, C/D .
2. The overload factor at collapse (OF_c) was observed to occur at 120 sec, 130 sec and 140 sec, in loose sand, medium dense sand and dense sand, respectively. As the OF_c is the lowest for loose sand, the tunnel support is needed faster for loose sand than for much denser sand.
3. The surface settlement trough profile were wider at $C/D=3$ than the surface settlement trough profile at $C/D=2$ and $C/D=1$. Hence, the surface settlement increased nonlinearly by decreasing the tunnel depth. The highest value of surface settlement was 0.775 mm occurred at relative density of 30% for $C/D=1.0$. On the other hand, the lowest surface settlement for this study belongs to $C/D=3.0$ where the amount of settlement was only 0.29 mm and 0.20 mm for 30% and 75% relative density of sand, respectively.
4. The percentage differences of S_{max} increased from $C/D=1.0$ up to 2.0 at different relative density, but then decreased when the test was carried out at $C/D=3.0$. The percentage differences in maximum surface settlement clearly shows an increased value as the tunneling work was done in loose and medium dense sand. However, at relatively dense sand, the percentages difference became low. It can be concluded that in greenfield condition, the relative density and cover to diameter ratio affect the surface settlement.

Acknowledgement

The authors gratefully acknowledged the financial support given by the Ministry of Higher Education, Malaysia and the Universiti Teknologi Malaysia (UTM)

through the project under the Research University Grant scheme, RUG Vote No. Q.J130000.2522.06H60. Not to forget, acknowledgement is also due to all the staff in Geotechnics Laboratory, FKA, UTM for the assistance in carrying out the laboratory tests.

References

- [1] Neaupane, K. M. and Adhikari, N. R. 2006. Prediction of Tunneling Induced Ground Movement with the Multi Layer Perception. *Tunneling and Underground Space Technology*, 21: 151-159.
- [2] Peck, R. B. 1969. Deep Excavations and Tunneling in Soft Ground. *Proc., 7th Int. Conf. on Soil Mechanics and Foundation Engineering*, Sociedad Mexicana de Mecánica de Suelos (Mexican Society of Soil Mechanics), Mexico City, 225-290.
- [3] Attewell, P. B. and Woodman, J. P. 1982. Predicting the Dynamics of Ground Settlement and its Derivatives Caused by Tunneling in Soils. *Ground Engineering*, 15(8): 13-22.
- [4] Ahmed, M. and Iskander, M. 2011. Analysis of Tunneling-Induced Ground Movement Using Transparent Soil Models. *Journal of Geotechnical and Geoenvironmental Engineering*, 137: 525-535.
- [5] Zymnis, D. M. 2009. Thesis (S.M.): Evaluation of analytical methods to interpret ground deformations due to soft ground tunneling. *Massachusetts Institute of Technology, Dept. of Civil and Environmental Engineering*.
- [6] Antonio Bobet and Wei-I, C. 2001. Predictions of Ground Deformations in Shallow Tunnels in Clay. *Tunneling and Underground Space Technology*, 17: 3-19.
- [7] Marto A., Hajihassani, M., Makhtar, A.M. and Kasim F. 2014. A Review on the Laboratory Model Tests of Tunnels in Soft Soils. *Malaysian Journal of Civil Engineering*, 26(1): 89-98.
- [8] Meguid, M. A., Saada, O., Nunes, M. A. and Mattar, J. 2008. Physical Modelling of tunnels in Soft Ground: A review. *Tunneling and Underground Space Technology*, 23: 185-198.
- [9] Adachi, T., Kimura, M., Kishida, K. 2003. Experimental study on the distribution of earth pressure and surface settlement trough three-dimensional trapdoor tests. *Tunneling and Underground Space Technology*, 18(2):171-183.
- [10] Chambon, P., Corte, J.F. 1994. Shallow tunnels in cohesionless soil: stability of tunnel face. *Journal of Geotechnical Engineering*, 120(7):1148-1165.
- [11] Wu B. R. and Lee C. J. 2003. Ground Movements and Collapse Mechanisms induced by tunneling in Clayey Soil. *International Journal of Physical Modelling in Geotechnics*, 4:15-29.
- [12] Cording, E. J. and Hansmire, W. H. 1975. Displacements around soft ground tunnels. *American Conference on Soil Mechanics and Foundation Engineering Session*, IV: 571-632.