

SHEAR STRENGTH DEGRADATION OF SEMARANG BAWEN CLAY SHALE DUE TO WEATHERING PROCESS

Idrus M Alatas^{a*}, Samira A Kamaruddin^b, Ramli Nazir^c, Masyhur Irsyam^d, Agus Himawan^d

^aInstitut Sains dan Teknologi Nasional, Jakarta, Indonesia

^bUTM Razak School of Engineering and Advanced Technology, Universiti Teknologi Malaysia Kuala Lumpur, Malaysia

^cFaculty of Civil Engineering, Universiti Teknologi Malaysia, 81310 UTM Johor Bahru, Johor, Malaysia

^dTeknik Sipil Institut Teknologi Bandung, Bandung, Indonesia

Article history

Received

3 August 2015

Received in revised form

31 August 2015

Accepted

23 September 2015

*Corresponding author

hb_idrus@yahoo.com

Graphical abstract

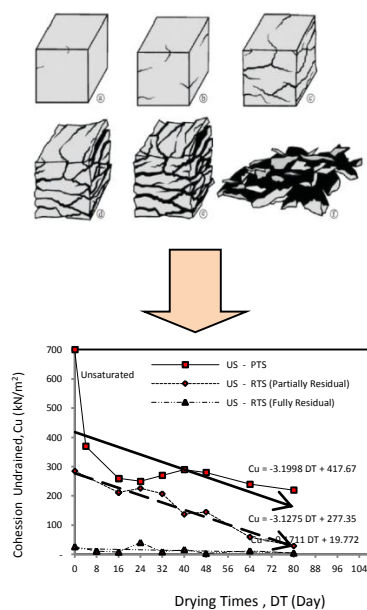

Abstract

The effect of weathering processes in decreasing the shear strength of clay shale had been done in this study. The drying process of clay shale with sunlight in the laboratory up to 80 days had been conducted to create the conditions of weathered sample. The peak and residual shear strength parameters of unsaturated and saturated clay shale were obtained from triaxial laboratory test, and all samples were tested on each 8 days of weathering process. Decrease of shear strength in peak and residual condition was obtained during 80 days of the drying process. The residual shear strength parameters were distinguished between residual shear strength without stress release and with stress release of confining pressure. The results up to 80 days of unsaturated clay shale showed that the cohesion at peak stress conditions reduced to 30 % based on initial shear strength before the occurrence weathering, while the internal angle friction reduced to 64 %. Residual cohesion without and with stress release reduced to 4 % and 1 %, respectively while residual internal angle friction without and with stress release reduced to 15 % and 5 %. Similar situation also occurs for the saturated clay shale samples.

Keywords: Clay Shale, weathering, shear strength, residual shear strength

Abstrak

Pengaruh dari proses luluhawa terhadap pengurangan kekuatan ricih dari syal tanah liat di laksanakan dalam kajian ini. Proses pengeringan syal tanah liat melalui panas matahari telah dilakukan di makmal sehingga 80 hari untuk mendapatkan sampel yang terluluhawa. Parameter kekuatan ricih pada nilai puncak dan baki dari sampel tak tepu dan tepu melalui ujian tiga paksi di makmal, dengan semua sampel diuji pada setiap 8 hari dalam proses luluhawa tersebut. Penurunan kekuatan ricih pada nilai puncak dan baki telah diperolehi sehingga 80 hari proses pengeringan. Parameter kekuatan ricih baki dibezakan antara kekuatan ricih baki tanpa pengurangan tegasan dan dengan pengurangan tegasan melalui tegasan sel. Hasil sehingga 80 hari syal tanah liat tak tepu menunjukkan bahawa kejelekitan pada keadaan pucak menurun kepada 30 % berdasarkan kekuatan ricih sebelum berlaku luluhawa manakala sudut geseran dalam menurun kepada 64 %. Kejelekitan baki tanpa dan dengan pengurangan tegasan, masing-masing menurun kepada 4 % dan 1 %, manakala sudut geseran dalam baki tanpa dan dengan pengurangan tegasan menurun kepada 15% dan 5%. Keadaan yang sama juga telah berlaku pada sampel syal tanah liat yang tepu.

Kata kunci: Syal tanah liat, luluhawa, kekuatan ricih, kekuatan ricih baki

© 2015 Penerbit UTM Press. All rights reserved

1.0 INTRODUCTION

Clay shale often found in Indonesia, especially in Java, such as West Java, Central Java and other areas in Indonesia. Clay shale which originally as claystone has a high shear strength when it is in the nature protected by other soil as overburden will drop drastically when having direct contact with atmosphere and hydrosphere. As can be seen in Figure 1, clay shale changed due to weathering over time [1].



Figure 1 Changes in physical form of clay shale over time [1]

Shear strength of clay shale rapidly decreases as the clay shale has impaired due to processes of weathering, such as drying and the loss of stress [1]. As a result of the weathering processes, parameter of clay shale shear strength that has been tested in the laboratory changed significantly as compared to its original undisturbed condition. The clay shale shows different behavior from other types of clay in generally because clay generally will increase the shear strength when performed drying in the sun.

Two landslide cases that have stunned people in Indonesia include landslide in the Sports Training Center in Hambalang Sentul and landslide in Semarang-Bawen Tol Road, Central Java. In 2012, landslide occurred in the infrastructure construction of Sports Education Center in Hambalang Sentul, West Java. The landslide required large work of cut and fill, as shown in Figure 2. Several clay soil reacts with air and led to soil erosion in the project [2].



Figure 2 Landslide case in the Sport Training Center project at Hambalang Sentul, West Java [3]

Another landslide occurred in KM. 32+000 toll road Semarang-Bawen in Central Java due to exposure of clay shale slopes as a result of cuts for the purposes of

the toll road (refer to Figure 3). The layer of clay shale was exposed and reacted with atmosphere and caused a sudden collapse to the weathered clay shale slope [3].



Figure 3 Landslide case in Semarang-Bawen Toll Road KM 32+000[4]

2.0 BEHAVIOUR AND PERFORMANCE OF CLAY SHALE

Engineering behavior of clay shale is a very complicated subject. If exposed to sunlight, air and water in a short time, clay shale will weathering and changed into soft clay. From previous studies, clay shale is an integral part of the clay stone (Clay-Bearing Rocks) [5], besides mud stone and silt stone [6]. The changes can be in the form of physical disintegration or chemical decomposition. In tropical climates region, such as Indonesia, the process is generally more common than other climatic conditions [7]. Figure 4 shows an illustration of that destruction process caused by weathering of the clay shale [8]. General mineralogy of clay stone is mainly composed of fine-grained particles, i.e. clay mineral sand rock flours. It is already well known that the rocks containing Smectite and Pyrite minerals may disintegrate when they are exposed to air and water [9], as shown in Figures 4.

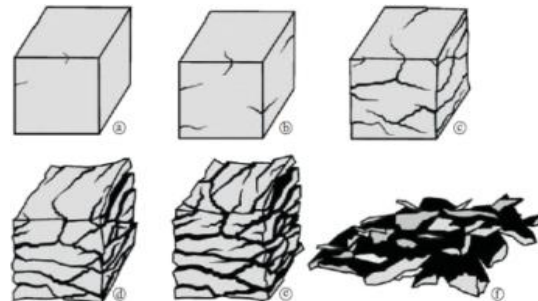

Figure 4 Illustration of general appearances of the body slaking mode of mudrocks under exposure condition clay shale behavior change over time due to drying process [8]

From drained direct shear box test, the shear strength of soaked clay shale shows dramatic decrease compared to unsoaked clay shale. Soaked residual and remoulded residual shear strength will be lower when compared to soaked peak stress and remoulded peak stress as shown in Figure 5(a) [10]. The disturbance effect has been supported in previous study [11] as indicated in Figure 5(b).

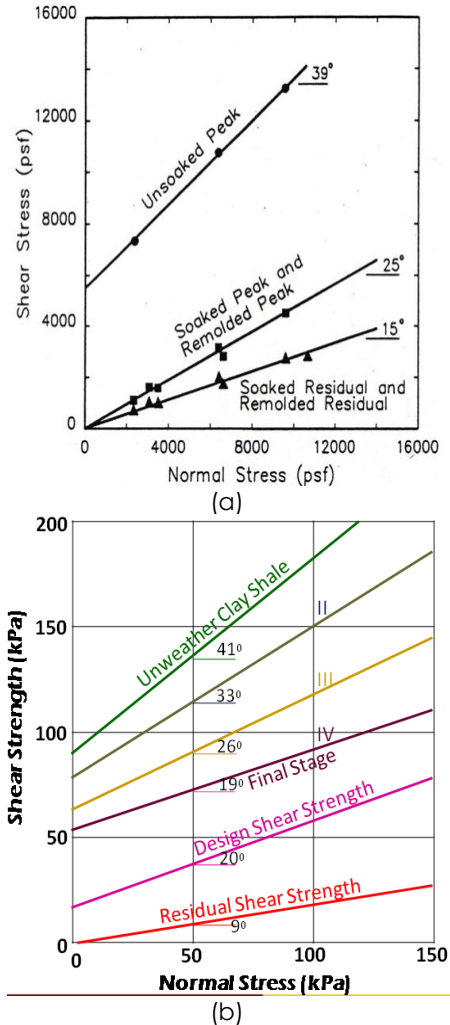

Figure 5 Results of (a) clay shale shear strength degradation from peak and residual with unsoaked and soaked samples [10] and (b) degradation of clay shale shear strength due to weathering grade effect compared with residual shear strength [11]

In northern provinces of West Java, Indonesia, a large formation of Subang clay shale has covered the areas. The formation of clay shale could disintegrate in shorter time when exposed to the atmosphere and hydrosphere, and led to some significant problems in design activities [12]. Weathering process has caused clay shale volume to change and reduce strength of the unconfined compression test [13].

Decreasing compression strength of clay shale and some type of rocks have been studied in with Schmidt Hammer Test [7]. The study has relating field testing with

intensity of weathering from the results of Schmidt Hammer value.

The relationship between weathering grade of clay shale and effective friction angle, and effective cohesion are shown in Figure 6. The increment weathering grade of clay shale will result ineffective internal angle friction and reduction of effective cohesion [14].

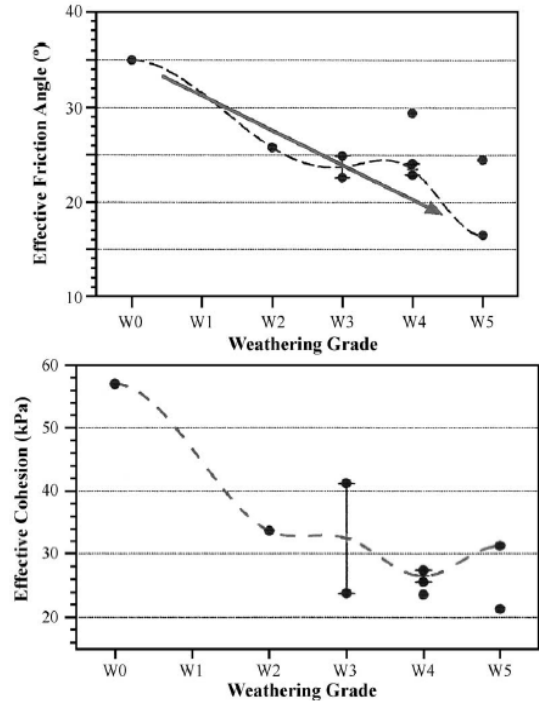

Figure 6 Correlation between effective shear strength parameter and weathering grade of clay shale [14]

3.0 METHODOLOGY

On 16th November 2013, a landslide occurred on cutting slope of KM 32+000 Semarang-Bawen toll road projects in Central Java Province. Construction of toll road embankment on clay shale has reactivated ancient landslide and resulted in large slope instability. Shear strength parameters for existing failure surface then must be derived from residual shear strength [4]. At this stage, residual shear strength parameters were determined as an important factor of safety factor accuracy.

To obtain the accurate residual shear strength parameters, some undisturbed and disturbed samples have been taken from test pit on the slope toe by using a core drilling machine. Clay shale samples were collected from the toe of affected slope. For this study, a field and laboratory testing were carried out to obtain physical and mechanical properties, as well as mineralogy of clay shale. As shown in Figure 8, Smectite was a dominant mineral founded at the site followed by Illite, Kaolinite and Chlorite (refer to Table 1). Microscopic figures of clay shale by using scanning electron microscopes (SEM) are shown in Figure 9.

Physical and mechanical properties of Semarang-Bawen clay shale can be referred to Table 2.



Figure 7 Landslide location at Semarang-Bawen toll road and test pit sampling work

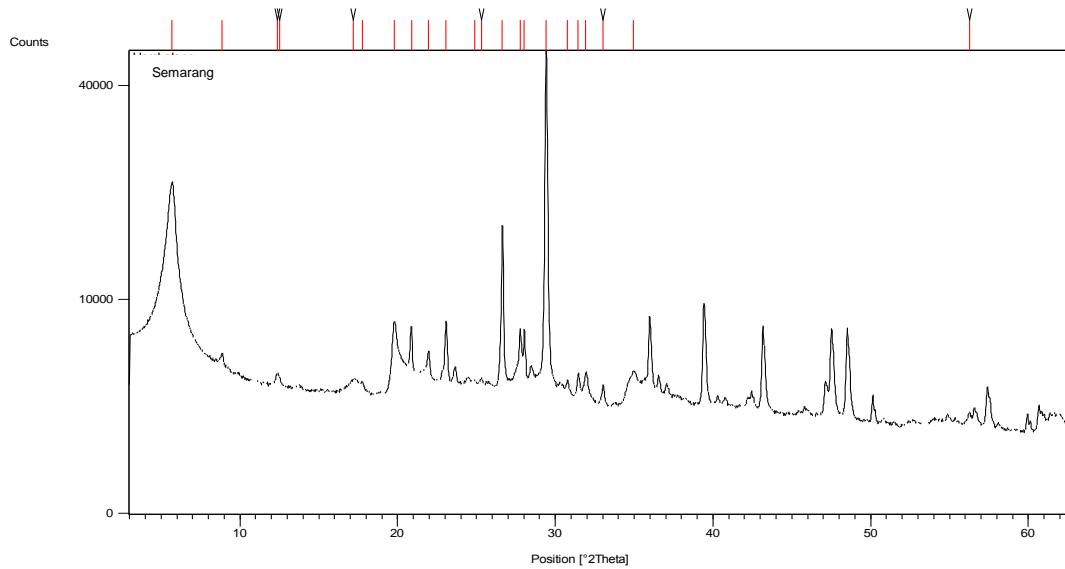

Figure 8 X-ray diffraction (XRD) of clay shale Semarang-Bawen [15]

Table 1 Name of compound and chemical formula for Semarang-Bawen mineralogy of clay shale [15]

Compound Name	Composition (%)	Chemical Formula
Smectite (Nontronite)	50	$\text{Na}_{0.3}\text{Fe}_2\text{Si}_4\text{O}_{10}(\text{OH})_2 \cdot 4\text{H}_2\text{O}$
Illite	3	$(\text{K}, \text{H}_3\text{O}) \text{Al}_2 \text{Si}_3 \text{Al} \text{O}_{10}(\text{OH})_2$
Kaolinite	2	$\text{Al}_2\text{Si}_2\text{O}_5$
Chlorite	1	$(\text{Fe}, \text{Mg}, \text{Al})_6(\text{Si}, \text{Al})_4\text{O}_{10}(\text{OH})_8$
Calcite	30	CaCO_3
Siderite	2	$\text{Fe}_2 + \text{CO}_3$
Quartz	8	SiO_2
Plagioclase	3	$(\text{Na}, \text{Ca})(\text{Si}, \text{Al})_4\text{O}_8$
Pyrite	1	FeS_2
Total	100	

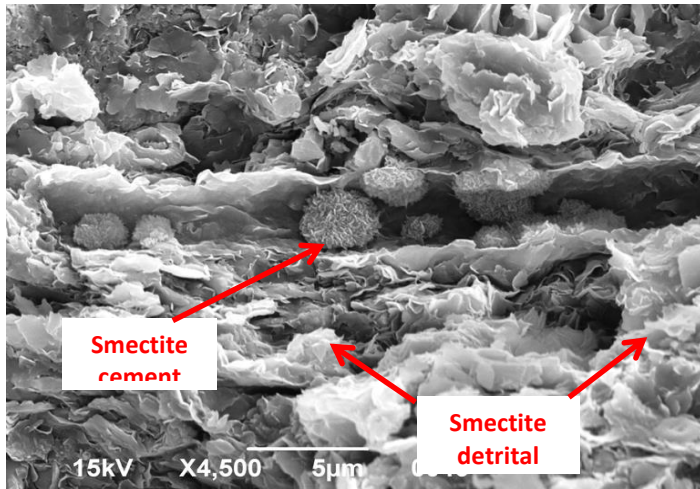

Figure 9 SEM images of Semarang-Bawen clay shale with scale 4500x [15]



Figure 10 Drying room of clay shale in laboratory

Table 2 Physical and mechanical properties of Semarang-Bawen clay shale

Properties	Value
Bulk density, γ (kN/m ³)	20.3 - 21.6
Water content, w (%)	15.3 - 18.5
Dry density, γ_d (kN/m ³)	17.6 - 18.6
Void ratio, e	0.465 - 0.517
Specific gravity, G_s	2.66 - 2.68
Liquid limits, LL (%)	59.12
Plastic limits, PL (%)	29.18
Plasticity index, PI (%)	29.23
Sand (%)	0.92
Silt (%)	45.08
Clay (%)	54.00
Undrained cohesion, c_u (kN/m ²)	700
Internal angle friction, ϕ_u (°)	59.4
Residual undrained cohesion, c_{ur} (kN/m ²)	285
Residual internal angle friction, ϕ_{ur} (°)	46

In laboratory, each sample of unsaturated clay shale was given different confining pressure to achieve the

peak stress and was left until it reached residual condition.

When the residual stress was stable, the test was continued by using a multistage system to obtain residual shear strength by gradually increasing the confining pressure [16] [17]. For the first sample, the confining stress after the peak stress was 39 kN/m² (CP-1). The confining pressure was increased from CP-1 of 39 kN/m² to CP-2 of 78 kN/m² until the stress condition was stable. Then, the test has been continued to increase at the CP-3 confining pressure of 118 kN/m² and lasted at the CP-4 confining pressure of 157 kN/m².

Similar procedure had been performed for the second and third clay shale samples. The initial confining stresses for the second and third samples were CP-2 of 78 kN/m² and CP-3 of 118 kN/m², respectively. After the stage, all confining pressures were returned to zero (i.e., stress release) and the test was continued to obtain fully residual shear strength. The stress-strain curves for the triaxial UU test method are illustrated in Figure 11.

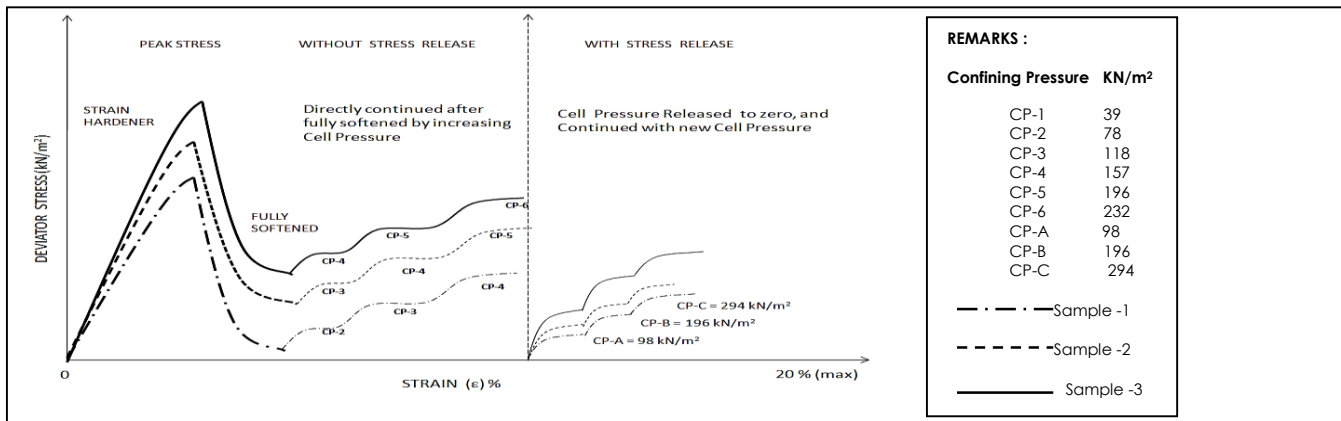

Figure 11 A continuous unsaturated triaxial UU test was conducted by multistage system to obtain residual strength without stress release and residual shear strength with stress release

After all parameters were obtained, a back analysis was carried out to determine the actual shear strength parameter that caused the slope failure by using Plaxis software and the value of this parameter should be in the range of residual shear strength parameters were obtained in laboratory test. [4]. Results of the analysis are given in Figure 12.



No	Layer	c_u' (kPa)	ϕ_u' (°)
1	Silty clay	15.0	20
2	Weathered Tuff Breccia	50	30
3	Tuff Breccia	100	38
	Solid on Tuff Breccia	R was assumed for back analysis of SF=1	
4	Clay shale	200	40
	Weathered clay shale	10	18

Figure 12 Calculated actual shear strength parameter when the SF = 1 from the back analysis by using Plaxis software

4.0 RESULTS AND DISCUSSION

The drying clay shale was carried out on 0 day, 4 days, 8 days, 16 days, 24 days, 32 days, 40 days, 48 days, 64 days and 80 days to determine the effect of clay shale

weathering. The samples took up to 4 days to be fully saturated because the clay shale has high density and low porosity. The clay shale was considered fully saturated when Skempton B coefficient becomes close to 1. Drying process was carried out in a room with transparent roof and walls' (drying room) exposed directly to sunlight and was protected from the rain.

4.1 The Relationship between Shear Strength and Principles Stress

Reduction of shear strength parameter by the Coulomb equation was determined in peak stress condition and residual stress condition. At the peak stress condition, shear strength parameter was obtained for peak of total stress and effective stress. Residual stress after peak stress condition and after stress release condition were determined as residual shear strength without stress release (c_{urp} and ϕ_{urp}) and after stress release as residual shear strength with stress release (c_{urf} and ϕ_{urf}). Relationship between shear strength and principles stress of 0 day, 40 days and 80 days of drying effect weathered are shown in Figures 13 to 15 respectively.

4.2 Reduction of Shear Strength

Drying process as one of weathering process has shown decreases in shear strength properties of clay shale. Significant changes of shear strength reduction had been seen when the clay shale has been exposed to atmosphere in which oxygen and hydrogen caused the clay shale to weathered [7]. The process of clay shale weathering becomes faster by considering wetting and drying processes. Frequent wetting and drying phenomena could create rapid weathering process. Reduction of effective cohesion and internal angle of the samples up to 80 days of drying process are shown in Figures 16 to 18.

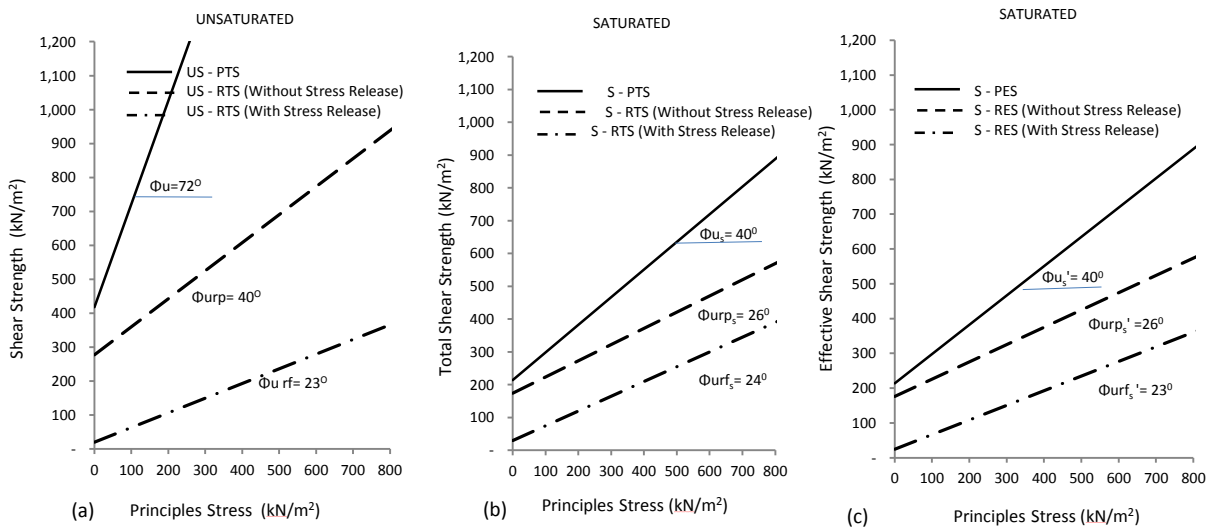

Figure 13 Relationship between shear strength and principles stress Semarang-Bawen clay shale at 0 day of drying process for (a) unsaturated samples, Peak Total Stress (PTS) and Residual Total Stress (RTS), (b) saturated samples, Peak Total Stress (PTS) and Residual Total Stress (RTS), and (c) saturated sample, Peak Effective Stress (PES) and Residual Effective Stress (RES)

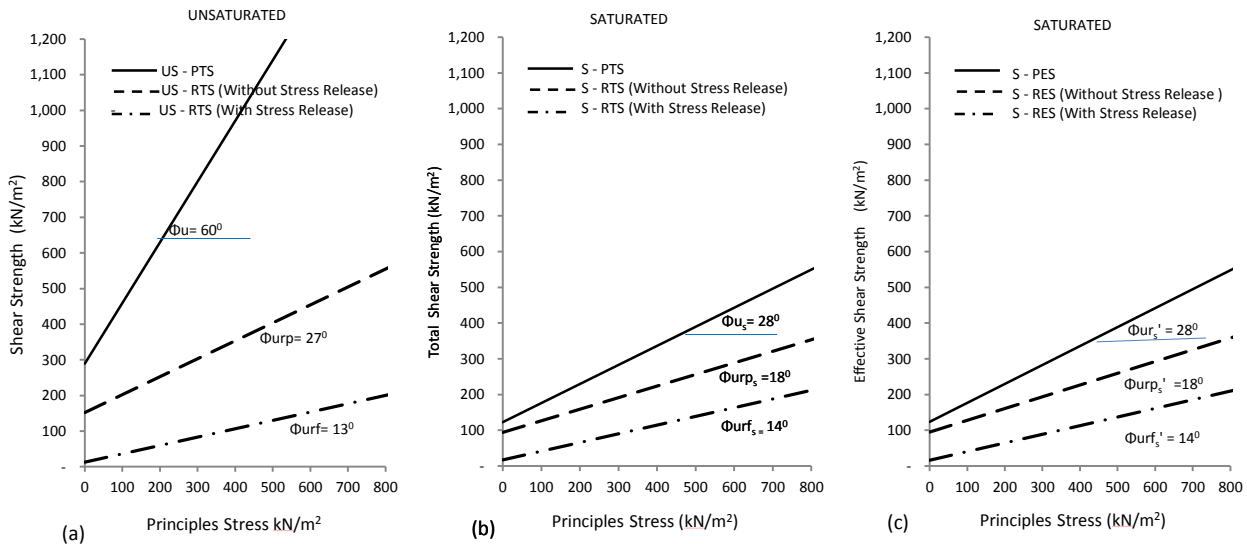

Figure 14 Relationship between shear strength and principles stress Semarang-Bawen clay shale at 40 day of drying process for (a) unsaturated samples, Peak Total Stress (PTS) and Residual Total Stress (RTS), (b) saturated samples, Peak Total Stress (PTS) and Residual Total Stress (RTS), and (c) saturated sample, Peak Effective Stress (PES) and Residual Effective Stress (RES)

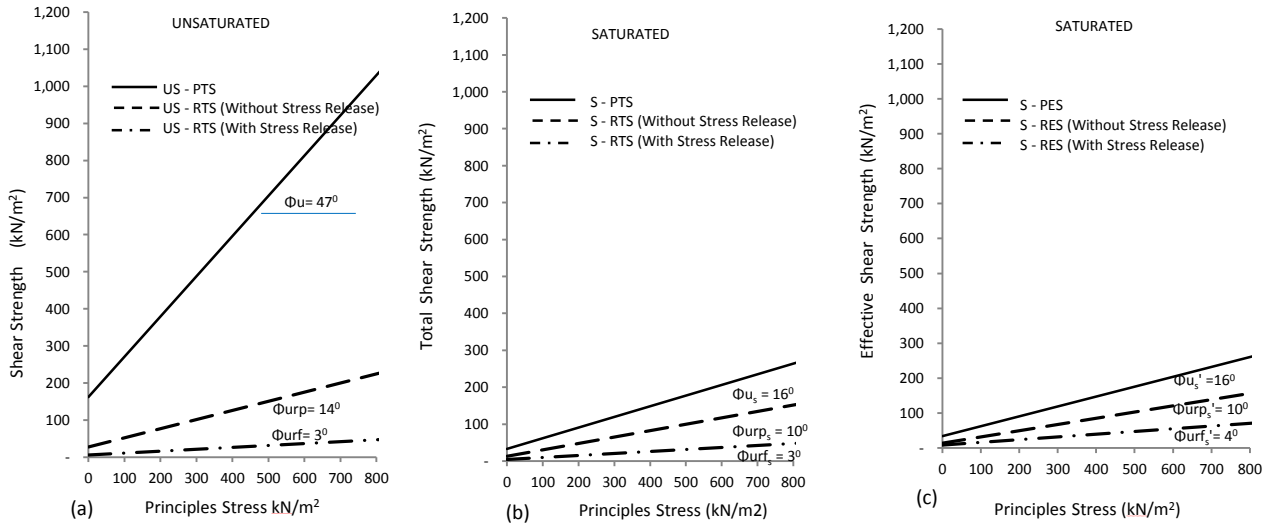

Figure 15 Relationship between shear strength and principles stress Semarang-Bawen clay shale at 80 day of drying process for (a) unsaturated samples, Peak Total Stress (PTS) and Residual Total Stress (RTS), (b) saturated samples, Peak Total Stress (PTS) and Residual Total Stress (RTS), and (c) saturated sample, Peak Effective Stress (PES) and Residual Effective Stress (RES)

From Figures 13 to 15, reduction of shear strength parameters in peak total stress (PTS) due to weathering drying process occurs in both unsaturated and saturated clay shale, albeit the degree of reduction of shear strength in saturated clay shale slightly faster than unsaturated clay shale. Not much different for the residual shear strength parameters of unsaturated and saturated clay shale at the same time of drying day of the residual stress conditions. Same thing goes to the total shear stress and effective shear stress.

The high value of bulk density of clay shale (21.16 kN/m³) compared with other clays in general, as well as

the small value of void ratio (0.416) causes long duration of clay shale saturation procedure using triaxial cell. The samples took 4 days to be fully saturated (i.e., B Value ≈ 1) prior to loading. Other clays generally take only 12 to 24 hours to be fully saturated. Therefore, the pore water pressure under loading is very small, so that the shear strength at total stress approximately equal to shear strength at effective stress.

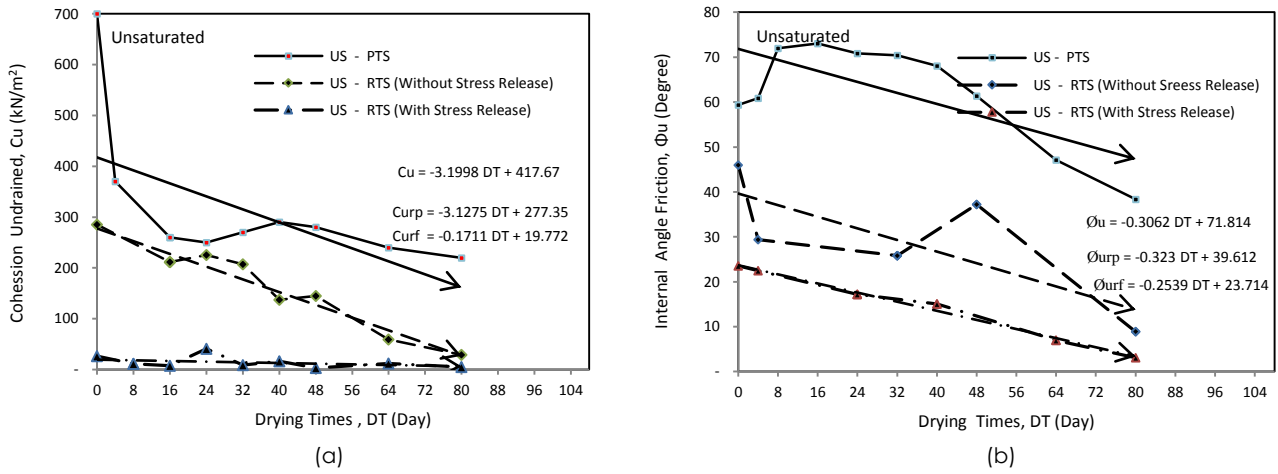

Figure 16 Results of (a) cohesion degradation and (b) internal angle friction degradation up to 80 days of drying process for unsaturated clay shale samples at Peak Total Stress (US-PTS) and Residual Total Stress (US-RTS)

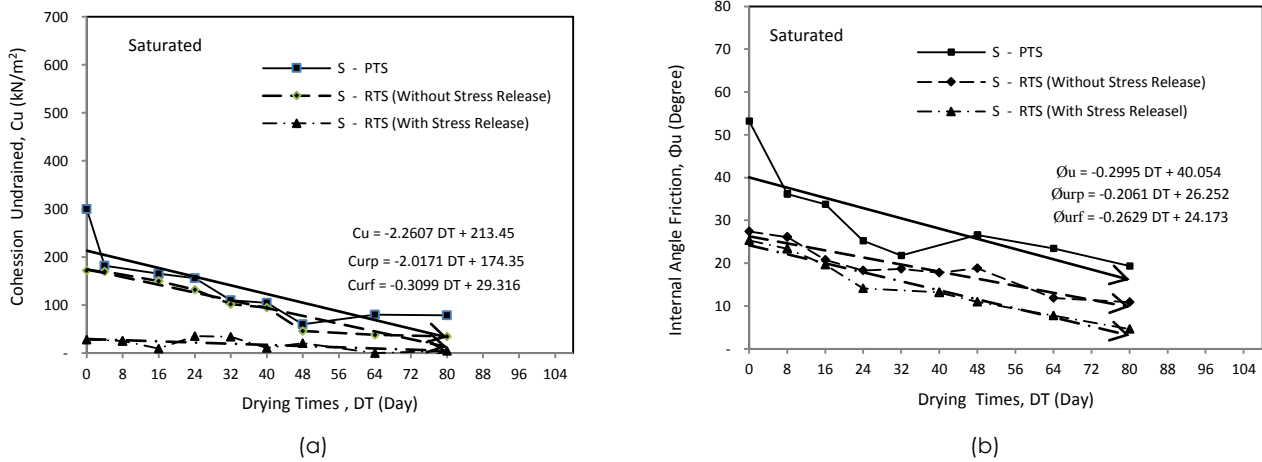

Figure 17 Results of (a) cohesion degradation and (b) internal angle friction degradation up to 80 days of drying process for saturated clay shale samples at Peak Total Stress (S-PTS) and Residual Total Stress (S-RTS)

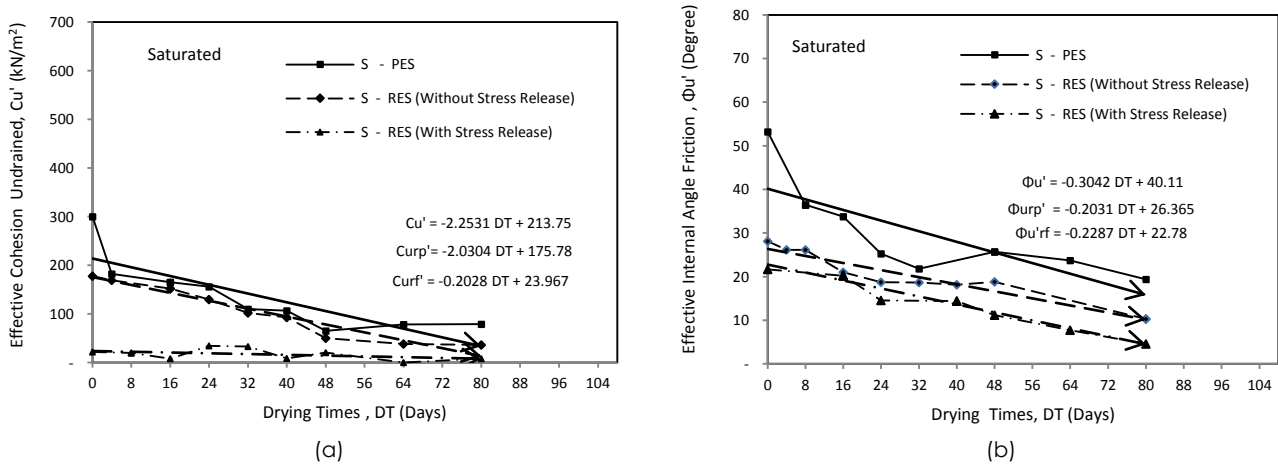

Figure 18 Results of (a) cohesion degradation and (b) internal angle friction degradation up to 80 days of drying process for saturated clay shale samples at Peak Effective Stress (S-PES) and Residual Effective Stress (S-RES)

The summary of shear strength reduction due to drying clay shale in the sun in 80 days of drying can be seen in Table 3 (a) to (c). In Table 3(a), percentage of cohesion and internal angle friction at the peak stress decreased to 31% and 64% for unsaturated clay shale, and 10% and 32% for saturated clay shale, respectively. Table 3(b) shows percentage of cohesion and internal angle friction at the residual stress without stress release decreased to 4% and 15% for unsaturated clay shale, and 5% and 18% for saturated clay shale, respectively. In Table 3(c), similar reduction can be seen in percentage of cohesion and internal angle friction at the residual stress with stress release, 1% and 5% for unsaturated clay shale, and 1% and 8% for saturated clay shale, respectively. The percentage is calculated based on the parameters of shear strength prior to beginning of weathering.

Table 3(a) Summary of shear strength reduction at the peak stress condition

Drying Time (day)	PEAK STRESS CONDITION					
	Cohesion Undrained			Internal Angle Friction		
	UnSat	Saturated		UnSat	Saturated	
	Cu kN/m ²	Cu _{tot} kN/m ²	Cu _{eff} ¹ kN/m ²	Øu kN/m ²	Øu _{tot} kN/m ²	Øu _{eff} ¹ kN/m ²
0	700	300	300	59.4	53.2	53.2
40	270	105	107	68.1	24.2	23.7
80	220	70	79	38.1	19.3	19.3
Reduction (%)	31 %	10 %	11 %	64 %	32 %	32 %

Table 3(b) Summary of residual shear strength reduction at the residual stress without stress release

Drying Time (day)	RESIDUAL STRESS WITHOUT STRESS RELEASE					
	Cohesion Undrained			Internal Angle Friction		
	UnSat	Saturated		UnSat	Saturated	
	Cur kN/m ²	Curp kN/m ²	Curp' ¹ kN/m ²	Øu kN/m ²	Øurp kN/m ²	Øurp' ¹ kN/m ²
0	285	172	177	46	27.4	28.1
40	207	95	93	31.5	17.8	18.3
80	29	35	36.5	8.9	10.8	10.2
Reduction (%)	4 %	5 %	5 %	15 %	18 %	17 %

Table 3(c) Summary of residual shear strength reduction at the residual stress with stress release

Drying Time (day)	RESIDUAL STRESS WITH STRESS RELEASE					
	Cohesion Undrained			Internal Angle Friction		
	UnSat	Saturated		UnSat	Saturated	
	Cur kN/m ²	Curp kN/m ²	Curp' ¹ kN/m ²	Øu kN/m ²	Øurp kN/m ²	Øurp' ¹ kN/m ²
0	26.7	28	21.7	23.5	25.3	21.6
40	16.5	10.7	9	15	13.2	14.4
80	5	4.7	8.3	3.1	4.6	4.6
Reduction (%)	1 %	1 %	1 %	5 %	8 %	8 %

4.3 Effect of Drying Process in Shear Strength Reduction

The drying process has resulted reduction of clay shale shear strength parameters. Cohesion and internal angle friction at peak stress and residual stress conditions decreases with increasing of drying time. It is applicable to unsaturated and saturated clay shale samples. The initial cohesion of unsaturated clay shale

at 0 day of drying time is 700 kN/m² and reduced to 5 kN/m² up to 29 kN/m² after 80 days for without and with stress release, respectively.

The results of triaxial test for unsaturated clay shale in peak stress indicate that internal angle friction parameters greater than 45° with value ranging between 47° and 72° and created joint roughness as illustrated in Figure 19(a). The illustration shows a joint surface with identical asperities rising at an angle *i*. Considering the angle of a smooth joint as ϕ_u , at the moment of peak shear stress, resultant force "R" on the joint is then oriented at an angle ϕ_u normal to the surface on which the motion is about to occur. Since this surface is inclined *i* degrees with the joint plane, the roughness angle *i* can be any value from 0 to 40° or more at low confining pressure [18]. The accuracy and utility of this concept has been demonstrated by Patton's law [19]. Figure 19(b) shows bilinear failure criterion for the joint representing the merging of Patton's law and the condition for sharing through asperities as follows:

$$\tau_p = \sigma \tan (\phi_u + i) \text{ for } \sigma \text{ small} \quad (1)$$

and

$$\tau_p = S_j + \sigma \tan \phi_r \text{ for } \sigma \text{ large} \quad (2)$$

Figure 20 shows results from triaxial test for the case of unsaturated Semarang-Bawen clay shale. The results showed that roughness effect occurred around failure plane. In common cases, unsaturated clay shale that exists before weathering has the same behaviour as rocks. The roughness effect occurs if small pressure is used to obtain internal angle friction parameters greater than 45°. Therefore, roughness joint effect does not occur if the saturated clay shale is in weathered or residual condition.

5.0 CONCLUSION

A field and laboratory testing were carried out to examine the behaviour of shear strength reduction of drying clay shale. Drying process was selected as one of the weathering phenomena. Effect of drying clay shale in the sun up to 80 days has led to reduction in peak shear strength and residual shear strength. The parameters decreased with increasing of drying time and happened to both unsaturated and saturated clay shale samples. The initial cohesion of unsaturated clay shale with and without stress release was reduced dramatically after 80 days.

The triaxial test of unsaturated clay shale resulted roughness effect around failure plane of the samples. This means that joint roughness does not occur if the saturated clay shale is in weathered or residual condition.

Because of the behavior of clay shale before it weathered like rocks, then the use of triaxial apparatus with high load capacity is recommended to be used in further research, in order to minimize the effect of joint roughness.

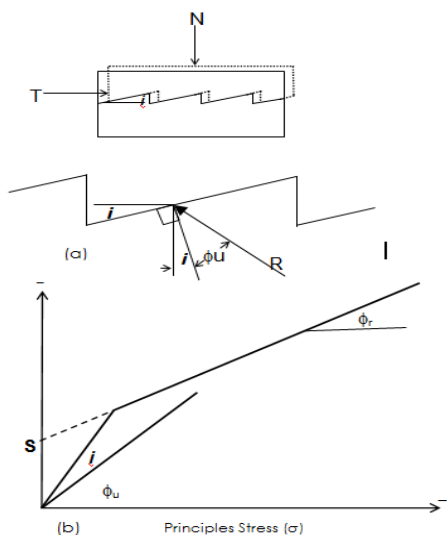

Figure 19 Schematic of (a) the basic of Patton's law for joint shear strength and (b) bilinear shear strength criterion [18]



Figure 20 Joint roughness effect around failure plane on unsaturated Semarang-Bawen clay shale from triaxial test

Acknowledgements

This research has been conducted based on MoU between Indonesian Society for Geotechnical Engineering with the Faculty of Civil Engineering, Universiti Teknologi Malaysia. The authors would like to express their sincere appreciation for the research collaboration.

References

- [1] Irsyam M., Jayaputra. A. A., Himawan A. and Kartawiria A. 2011. Kasus-Kasus Kelongsoran Pada Tanah Clay Shale dan Alternatif Penanggulangannya. *Proceeding of the 9th Indonesian Society for Geotechnical Engineers Conference and 15th Yearly Scientific Meeting*. Jakarta .
- [2] Idrus M. A. 2010. Soil Investigation Report : Pusdiklat Dan Sekolah Olah Raga Nasional, Hambalang, Sentul, Jawa

- Barat. in Final Report Soil Investigation. *Geoinves Soil Mechanics Laboratory*. Jakarta.
- [3] Idrus M. A., 2012. *Geotechnical Engineering Aspect In Infrastructure Building On Difficulties Soil*. C-Line Civil Eng Departement of ISTN.
- [4] LAPI ITB PT., 2013. Alternatif Mitigasi Kelongsoran dan Perkuatan Lereng Galian Tower SUTT STA 19+255 Pembangunan Jalan Tol Semarang - Solo Tahap I Ruas Ungaran-Bawen Paket V Tinalun - Lemah Ireng STA 18+000 - 21+825. in Technical Report LAPI ITB PT.
- [5] Shakoor A., Tej. P.G. 2011. Assessing The Slaking Behaviour of Clay- Bearing Rock. *10th Annual Technical Forum Geohazards Impacting Transportation In The Appalachian Region*. Columbus Ohio USA.
- [6] Nandi A. and Shakoor A. 2008. Application Of Logistic Regression Model For Slope Instability Prediction in Cuyahoga River Watershed, Ohio, USA. *Georisk*. 2(1): 16-27.
- [7] Sadisun I. A., Andri S. S., Asep N., and Prihananto S. 2006. Weathering Of Some Selected Rock Types And Their Strength Degradation Obtained From Schmidt Hammer. *Proceeding PIT IAGI Riau, The 35th IAGI Annual Convention and Exhibition* .Pekanbaru – Riau. 21 – 22 November 2006.
- [8] Sadisun I. A., Bandonu H., Shimada, M., Ichinose, and Matsui K. 2010. Physical Disintegration Characterization of Mudrocks Subjected to Slaking Exposure and Immersion Tests. *Jurnal Geologi Indonesia*. 5 (4). Desember 2010: 219-225.
- [9] Sadisun I. A., Bandonu H., Shimada, M., Ichinose, and Matsui K. 2004. Textural And Mineralogical Properties Of Argillaceous Rocks In Relation To Their Propensity To Slaking. *Engineering Geology for Sustainable Development in Mountainous Areas, Free & Aydin (eds) © 2004 Geological Society of Hong Kong*. ISBN 962 7320 07 2.
- [10] Timothy D. S., Duncan., and Michael., 1991. Mechanisms of strength loss in stiff clays. *Journal of Geotechnical Engineering*. 117(1): 139-154.
- [11] Gartung E. 1986. Excavation of The Hard Clays of The Keuper Formation. *Proceeding of Symposium Geotechnical Engineering Division*. Seattle, Washington.
- [12] Sadisun Sadisun I. A., Shimada M., Ichinose M., and Matsui K. 2005. Study On The Physical Disintegration Characteristics Of Subang Claystone Subjected To A Modified Slaking Index Test. *Geotechnical and Geological Engineering* . 23: 199–218.
- [13] Sadisun I. A., Shimada M., Ichinose M., and Matsui K. 2002. An Experimental Study Of Swelling Strain In Some Argillaceous Rocks By Means Of An Improvedunconfined Swelling Test. *Rock Engineering Problems and Approches in Underground Constuction*. Choi, Ryu, Jeon & Moon (eds).
- [14] Emberhardt E., Thuro K., and Luginbueh M. 2004. Slope Instability Mechanisms in dipping interbedded conglomerates and weathered marls- The 99 Ruffi landslide Switzerland. *Engineering Geology*. 77: 35-56.
- [15] SEM and XRD Lemigas Laboratory. 2015. Report for Semarang-Bawen and Hambalang Clay Shale. LEMIGAS: Jakarta.
- [16] ASTM D 2850-87. 1989. Unconsolidated Undrained Compressive Strength of Cohesive Soil in Triaxial Compression, in Annual Book of ASTM Standard.
- [17] Ho D.Y.F, Fredlund .D.E. 1982.A Multistage Triaxial Test For Unsaturated Soils. *Geotechnical Testing Journal*. GTJODJ.5 (1/2):18-25.
- [18] Goodman R E. 1989. *Intoduction to Rock Mechanics*. Second Edition. Canada: John Wiley & Sons.
- [19] Patton F. D. 1966. Multiple Modes Of Shear Failure In Rock. *Proceeding 1st Congress ISRM (Lisbon)*. 1: 509-513.