

Experimental Solid and Liquid Propellant Rocket Development in Universiti Teknologi Malaysia : 1992-2011

Wan Khairuddin Wan Ali , Ang Kiang Long* , Mohammad Nazri Mohd. Jaafar

Transportation Research Alliance (TRA), Faculty of Mechanical Engineering, Universiti Teknologi Malaysia, 81310 UTM Johor Bahru, Johor Malaysia

*Corresponding author: kianglong81@hotmail.com

Article history

Received: 13 August 2014
Received in revised form:
6 November 2014
Accepted: 1 February 2015

Graphical abstract

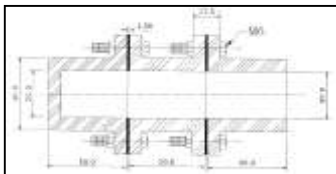

Abstract

This paper reports on the research and development activities related to the experimental solid and liquid propellant rocket in Universiti Teknologi Malaysia (UTM) from year 1992 to 2011. A total of 41 closed access academic theses and project papers from UTM library archive were exclusively selected for this review work. Some of these theses and papers originally written in Malay language were translated into English language in this paper for better understanding of the research community. This paper gives a historical insight on the apparatus and methodology designed for educational research activities related to rocket propulsion in UTM. With the available resources within UTM, a few chemical propellant using Ammonium Perchlorate, Potassium Nitrate and hydrogen peroxide as oxidizer were tested in UTM propulsion lab. Besides discussing the rocket fuel components, composite rocket body, ceramic nozzle and alternative binder using natural rubber also covered in this review work. Significant experimental results and numerical findings achieved by UTM researchers were included in this paper.

Keywords: Universiti Teknologi Malaysia; solid propellant; liquid propellant; rocket motor; static test.

Abstrak

Kertas penulisan ini melaporkan aktiviti pembangunan dalam bidang kajian roket propelan di Universiti Teknologi Malaysia (UTM) dari tahun 1992 sehingga ke tahun 2011. Sebanyak 41 buah tesis akademik dan penerbitan ilmiah yang dilabelkan sebagai bahan bacaan terhad dalam arkib perpustakaan telah dipilih secara eksklusif untuk penulisan kertas kerja ini. Sebahagian tesis akademik dan penerbitan ilmiah yang asalnya ditulis dalam bahasa melayu (atau Bahasa Malaysia) telah diterjemah ke bahasa Inggeris supaya senang difahami oleh para penyelidik antarabangsa. Kertas penulisan ini boleh dijadikan satu sumber rujukan yang bagus tentang peralatan penyelidikan dan cara penyelidikan yang direka khas untuk pembangunan roket teknologi di UTM. Beberapa jenis bahan bakar (atau oxidizer) seperti Ammonium Perchlorate, Potassium Nitrate dan hydrogen peroxide telah diuji dalam makmal tuhan UTM. Selain melaporkan bahan bakar, kertas penulisan ini juga membincangkan bahagian roket yang dibuat dengan bahan komposit, nozle berasaskan bahan seramik dan bahan campuran alternative berasaskan getah asli. Pada masa yang sama, kertas penulisan ini juga meliputi pencapaian dan penemuan saintifik penting yang dilaporkan dalam tesis akademik and penerbitan ilmiah tersebut.

Kata kunci: Universiti Teknologi Malaysia, propelan, roket motor, kajian statik.

© 2015 Penerbit UTM Press. All rights reserved.

1.0 INTRODUCTION

Universiti Teknologi Malaysia (UTM) was established as technical school in 1904. In 1941, it was upgraded to college status. The construction work of the new college buildings was affected by the World War II. However the technical college finally completed and officiated by British High Commissioner to Malaya in 1955. Engineering courses at diploma level were conducted at the college in early years before engineering courses at degree level were introduced in 1960. It took almost 10 years for the technical college to be officially declared as UTM on 1st April 1975. In 1985, a new campus was established at skudai, Johor with Kuala Lumpur campus remain operational¹.

Rocket research program in UTM started since 1989 through individual interest in developing small rocket motor for civilian application. Despite no official funding and unclear aerospace policy from Malaysia government, the UTM research team decided to venture into the development of solid propellant rocket motor. Before the first research grant was awarded in 1999, the research team had studied a strong foundation in nozzle and combustion chamber design, simple instrumentation, testing facilities and safety procedures².

The art of rocket propulsion was invented thousand years ago in China as gunpowder and later was further developed by various countries as ballistic missile and space launch vehicle³. Although there are tremendous reference literature published by the

international research community in rocket design and development, the knowledge in this area appeared to be limited among the local scientist in Malaysia.

This paper is organized as follows: (1) summarizes the research works from 1992 to 2000; (2) provides an overview of development in rocket motor from 2002 to 2011 as there is no relevant topic published in year 2001. A summary and conclusion is given in Section 4.

2.0 DEVELOPMENT BEFORE YEAR 2000

First experimental solid propellant in UTM was done by Kandiah Padmanathan in year 1992 using Ammonium Perchlorates (AP) as oxidizer, Aluminum (Al) powder as fuel and Polyvinylchloride (PVC) powder as binder. Low molecular Sebacic Acid (SA) was used as cross-linking agent in the propellant ingredient. Carbon (C) powder was used in the experiment to investigate the characteristic of the burning rate⁴. A total of 9 chemical compositions were evaluated with strand burning test at atmospheric condition. The compositions are shown in Table 1.

Strand burner samples were fabricated in the size of 4 mm x 4 mm x 20 mm. Optimum burning rate of 1.163 cm/s was observed for propellant No 9. Composition of propellant No 9 was used in the rocket motor for ballistic test. Thrust measurement was done with a simple ballistic test rig that consists of a weighting machine. The test rig is shown in Fig. 1.

In order to improve the thermal strength to the rocket motor structure, ceramic material that consists of 50 % fire brick and 50 % fire mortar was studied as insulation layer for the rocket motor nozzle and combustion chamber in year 1992. However, miscalculation in rocket motor design (Fig. 1) has caused a backfire in the ballistic test. The high tensile set screws that connected the rocket motor components were deformed and the threads were worn in the static test. It was suggested that the internal pressure has exceeded the designed combustion chamber pressure of 10 MPa and choking at the nozzle exit have contributed to the mishap.

Table 1 Compositions of propellant used by Kandiah Padmanathan⁴

Propellant no.	Formulation					Curing Temperature ($^{\circ}\text{C}$)	Curing Time (Hrs)	Burning rates (cm/s)
	AP	PVC	SA	Al	C			
1	80.0	20.0	-	-	-	170	1.5	Very slow
2	62.0	20.0	18.0	-	-	170	1.5	0.195
3	60.0	20.0	20.0	-	-	170	1.5	0.112
4	66.8	15.1	14.1	4.0	-	185	1.5	0.504
5	60.0	11.8	21.8	6.4	-	185	1.5	0.290
6	65.0	11.8	19.8	-	3.4	185	1.5	0.205
7	75.0	10.0	10.0	2.5	2.5	190	1.75	0.714
8	80.0	8.0	10.0	2	-	190	1.75	1.000
9	80.0	8.0	8.0	4.0	-	190	1.75	1.163
9a	80.0	8.0	8.0	4.0	-	190	1.75	1.155
9b	80.0	8.0	8.0	4.0	-	190	1.75	1.149
9c	80.0	8.0	8.0	4.0	-	190	1.75	1.150

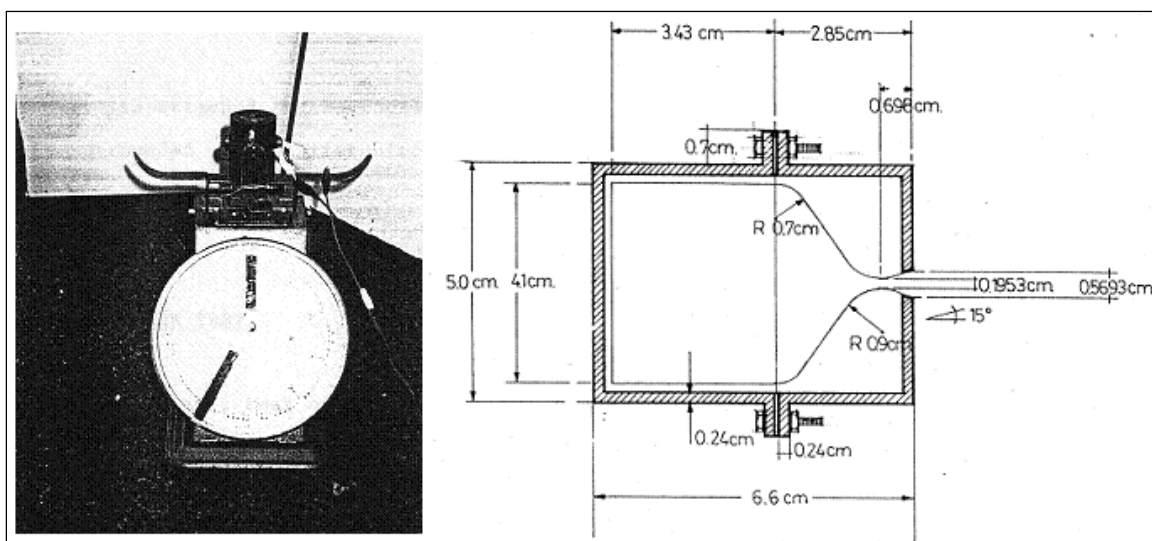

Figure 1 Simple test rig in Kandiah Padmanathan's experiment (left) and cross section view of rocket motor (right)⁴

Thrust measurement system available at UTM in 1992 was simple and the result was unsatisfactory. In order to capture accurate and reliable result, a test rig consists of electronic data acquisition (DAQ) system integrated with a load cell for rocket motor thrust measurement up to 10kg was designed by Liew⁵ in 1994. The test rig is illustrated in the schematic diagram in Fig. 2. Rocket motor was placed in vertical position and the thrust force was measured by placing a load cell under the rocket motor. The load cell consists of 4 column type active resistance strain gauges that was connected to a signal conditioner. The signal conditioner was designed to have a band-pass filter that operates at 0.1 to 1 kHz 3 dB frequencies 10 dB gain with 1 dB ripple width. Aluminum compensated strain gauges with gauge factor of 2.2 and 120 ohms resistant were installed in the system. A transducer-amplifier system was calibrated to a sensitivity of 0.2±0.1 Volt/kg.

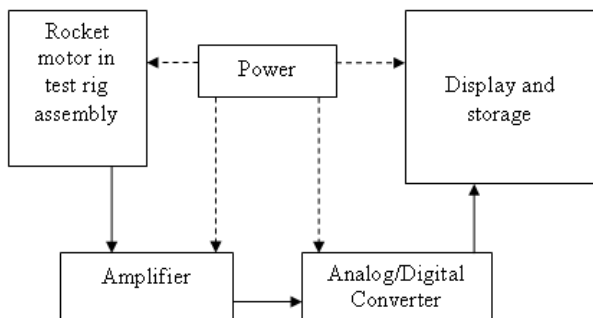

Figure 2 Schematic diagram of the rocket motor test rig⁵

Mu⁶ has continued Kandiah⁴ work by changing curing time to 4 hours and lowering curing temperature to 175°C. The method produced propellant grain with average density of 992.3 kg/m³. Five sets of mild steel nozzles which are listed in Table 2 were fabricated in the experiment. Fig. 3 showed the earliest design of Nozzle 1 in Mu's experiment which later the inlet diameter and exhaust diameter were altered from 30 mm to 32 mm.

Table 2 Nozzle configurations in Mu's experiment⁶

Nozzle no	Nozzle type	Inlet diameter D1 (mm)	Exhaust diameter D2 (mm)	D1/D2 ratio
1	Convergent	32.00	32.00	1.00
2	Convergent	32.00	26.75	1.20
3	Convergent	32.00	23.25	1.38
4	Convergent	32.00	19.72	1.62
5	Convergent	32.00	16.16	1.98

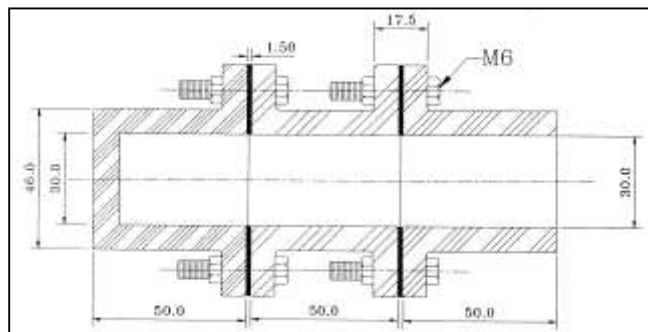

Figure 3 Design of nozzle 1 in Mu's report⁶

Some encouraging observations were recorded by Mu⁶. A constant flame with white smoke was observed at the end of the nozzle during firing process, followed with an aggressive burning behavior at the end of the burning process (Fig. 4). Mu suggests that the aggressive burning at the end of the burning process was due to the trapped air inside the solid propellant grain. There is no pressure leakage observed around the nozzle and the nozzle design survived the high temperature and pressure during the firing test.



Figure 4 Firing test in the Mu's experiment⁶

Beside achievements mentioned above, a custom build computer software namely COSMOS/M was used to study stress distribution and deformation of a pressurized vessel in year 1994⁷. Fig. 5 shows the analysis on a vessel with specified boundary displacement method. Due to the symmetrical shape of the model, the component was simulated quarterly in the computer program. It was found that the maximum stress experienced by the vessel under predefined pressure occurred at the connection area between cylinder and nozzle. Vessel specifications that were used in the simulation is presented in Table 3. A pressurized vessel manufactured by Malaysia Shipyard Engineering Company at Pasir Gudang in Johor state, Malaysia was analyzed with the developed computational method. The experimental result using strain gauges was in good agreement with the COSMOS/M result.

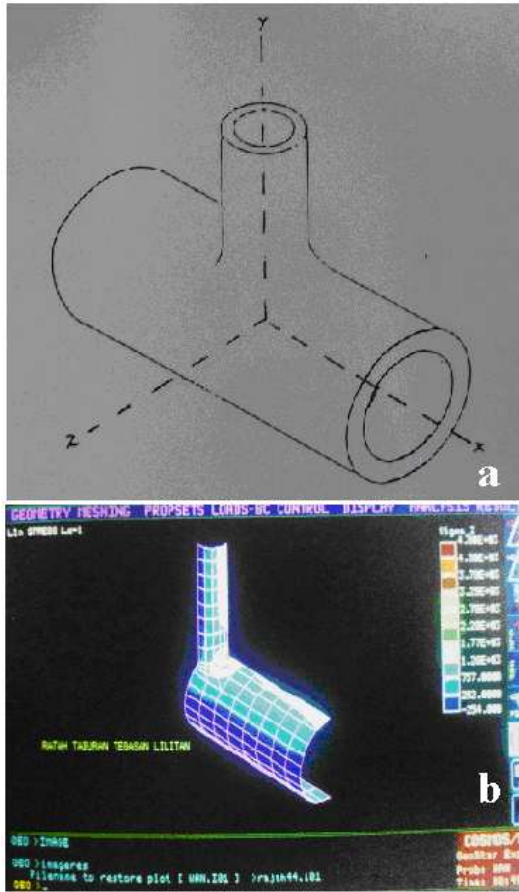

Figure 5 Pressure vessel for analysis (a) and stress distribution in computational analysis (b) ⁷

Table 3 Specification of the pressure vessel model ⁷

Properties	Cylinder	Nozzle
Applied pressure	0.689 MPa (100 Psi)	-
Young's Modulus	206.850 GPa (30x10 ⁶ Psi)	-
Outer diameter D _o	27.94 cm (11.00 in)	13.97 cm (5.50 in)
Inner diameter D _i	25.40 cm (10.00 in)	12.70 cm (5.00 in)
Length L	101.60 cm (40.00 in)	50.80 cm (20.00 in)

The same COSMOS/M computer software was also used by Arman Daut ⁸ for structural analysis on his rocket motor design in the same period of time. In Fig. 6, part 1, 2, 3, and 4 denote the component of the conceptual design of Kris-13. The Kris-13 was designed for surface to air missile mission. Analytical analysis was done on the Kris-13 rocket motor component design by considering composite propellant Flexadyne RDS-509 as solid propulsion fuel. A rocket model made of mild steel was fabricated without any firing test in this project. Thus, experimental ballistic test was suggested to understand the effectiveness of the design.

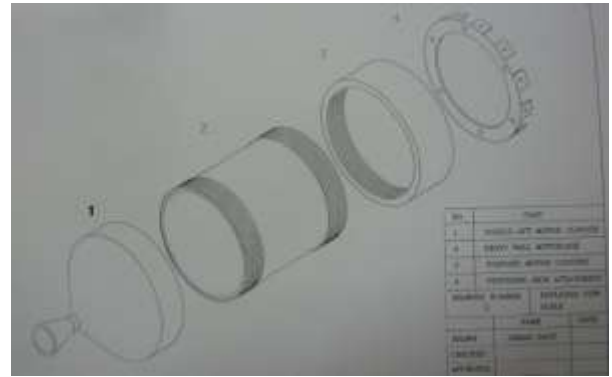

Figure 6 Conceptual rocket motor design by Arman Daut⁸

Two years after Arman Daut⁸ research, a ceramic element was used to insulate the nozzle wall was studied by K.C.Wong ⁹. A ceramic mixture with material code UTM-75FM25FB (75 % fire mortar and 25 % fire bricks) was molded according to the defined shapes shown in Fig. 7 as ceramic insert. The specifications of the fabricated ceramic inserts are presented in Table 4. The rocket motor was fabricated according to Mu's design⁶. High tensile set screws (M6 x 40) were used to assemble the mild steel case and nozzle (Fig. 8). Composite propellant (80 % AP, 10 % Al, 5 % PVC powder, 5 % low molecular S.A.) used in the ballistic test was cured for 1.5 hours at 175 °C. The ballistic test setup is shown in Fig. 9. Sand bags were used as safety precaution to block any flying fragments if mishap happened during the experiment.

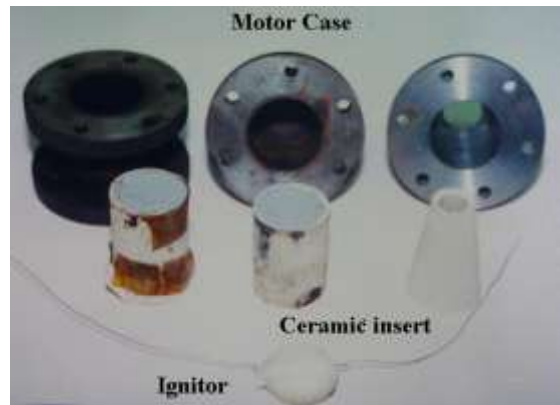

Figure 7 Ceramic insert with the rocket motor case and ignitor ⁹

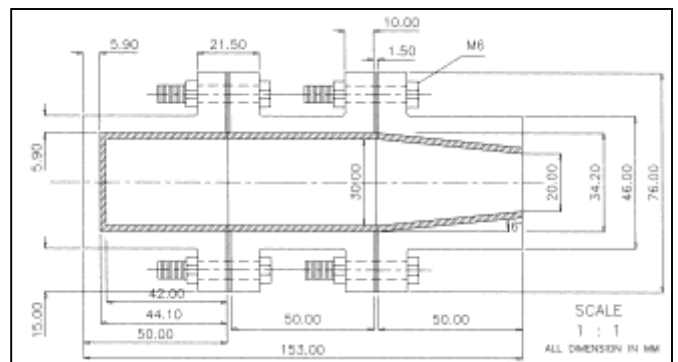

Figure 8 Rocket motor design used in the Wong's experiment ⁹

Table 4 Dimension of ceramic inserts used in K.C.Wong's experiment ⁹

Nozzle no	Nozzle type	Inlet diameter D1 (mm)	Exhaust diameter D2 (mm)	D1/D2 ratio	Ceramic thickness
1	Convergent	30.00	30.00	1.00	2.10
2	Convergent	30.00	20.00	1.50	2.10
3	Convergent	30.00	15.00	2.00	2.10

**Figure 9** Full assembly of rocket motor (left) and ballistic test setup (right) ⁹

The observations on the frame at nozzle exit for each type of nozzle were recorded using a video recorder. A white and slightly pink smoky flame of 15 cm was observed in the first ballistic test using Nozzle 1. After 10 seconds of burning time, a small explosion was occurred and the high exhaust pressure flung the ceramic insert out from the nozzle (Fig. 10). The 30 cm of yellowish smoky flame with sparks was observed in the second test using Nozzle 2, while Nozzle 3 produced the highest flame of 50 cm at the nozzle exit with bright and yellowish smoky flame. Fig. 11 shows the ceramic insert remained inside the nozzle in the second and third experiments with smooth burning and without explosion. K.C.Wong⁹ found that the ceramic insert able to act as a good thermal insulator to the combustion chamber and nozzle inner surface through the ballistic test.

**Figure 10** Observation in ballistic test for Nozzle 1⁹**Figure 11** Observation in ballistic test for Nozzle 2 (left) and Nozzle 3 (right) ⁹

3 years after K.C.Wong⁹ research in ceramic application for rocket motor, composite propellant made of Potassium Nitrate, Sucrose, and Aluminum powder was studied by Rizalman Mamat. Burning rates of the composite propellant under atmospheric condition was reported in Rizalman Mamat report¹⁰. Percentage of each chemical element was altered to observe their sensitivity influences on the burning behavior (Table 5). Two strand samples for each composition were tested accordingly in the burn rate test (Fig. 12). According to the experimental data that is shown in Table 5, sample no.16 has the highest burn rates of 1.715 cm/s among the samples, thus this chemical was selected for further verification in static thrust test. Solid propellant used in the static thrust test has the diameter of 30mm and length of 195mm.

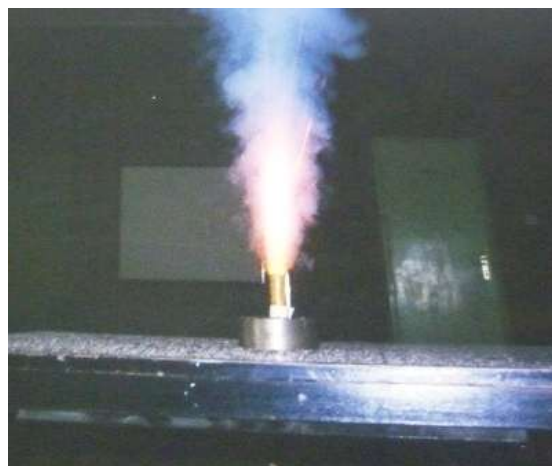
**Figure 12** Burn rate test for strand sample ¹⁰

Simple thrust measurement apparatus consists of a weighting machine and a support structure for the rocket motor was shown in Fig. 13. By referring to Mu's rocket motor design (Fig. 3), nozzle with inlet and exhaust diameter of 30mm was tested with 260 gram solid propellant. Black residue was observed in the rocket motor after the firing test. A reading of 2.5 kg of thrust force was recorded during experiment. A de Laval nozzle with inlet diameter of 30mm, throat diameter of 10mm and exhaust diameter of 28mm was fabricated for the rocket motor. The model rocket was loaded with 58 gram solid propellant was successfully launched vertically in this experiment. An explosion was observed when the model rocket nearly reached an altitude of 12 meter, which also the first rocket lift-off record since 1989.



Figure 13 Simple thrust measurement apparatus with weighting machine (left) and rocket motor after firing test (right) ¹⁰

Table 5 Burn rates of the studied propellant samples ¹⁰

Sample No.	Potassium nitrate (%)	Sucrose (%)	Aluminum (%)	Average Burn rates (cm/s)
1	75.00	25.00	0	0.743
2	70.00	30.00	0	0.474
3	65.00	35.00	0	0.757
4	60.00	40.00	0	1.249
5	55.00	45.00	0	0.489
6	50.00	50.00	0	0.581
7	45.00	55.00	0	0.140
8	40.00	60.00	0	0.034
9	55.25	29.75	15	0.439
10	56.55	30.45	13	0.600
11	57.85	31.15	11	0.583
12	59.15	31.85	9	0.638
13	60.45	32.55	7	0.693
14	61.75	33.25	5	1.137
15	63.05	33.95	3	1.233
16	64.35	34.65	1	1.715

A collaboration project between Malaysia Royal Armed Force (MRAF) and UTM to upgrade their manually operated weapon system was initiated in year 1999. The research objective was to reduce human workload during operation, while increasing the weapon accuracy. An electronic system using microcomputer was designed for Howitzer 105mm launcher by Khairul Ayob ¹¹. A microcomputer consists of multifunction DAQ card PCL818L was capable in adjusting the launcher vertically up to 80 degree. The electronic system was programmed to operate in MS DOS system.

■3.0 DEVELOPMENT AFTER YEAR 2000

Upon successful experiments on potassium nitrate based propellant in previous years, new fabrication method and formulation were studied by UTM researchers in year 2002¹². Fine potassium nitrate ($\pm 200\mu\text{m}$ with 99% purity) from Hamburg, Germany and sucrose were the main ingredients used in the experiments. Potassium nitrate was dried at 90°C in an oven for 24 hours before mixed with the ground sucrose. The mixture was stirred at rotation speed of 5 rpm for a period of 12 hours and homogenous mixture was expected after long hours of stirring process. The propellant mixture was then cured at 180°C for 30 minutes in a mould, before stored at room temperature for 12 hours to form an un-compressed propellant grain.

Mamat¹² used compressed mould method in the experiment by compressing the cured homogenous mixture with hydraulic press for five minutes to remove air bubble trapped within the mixture. The compressed grain was then sealed with industrial paper to avoid contamination from air moisture. Strand burning test on these samples at atmospheric pressure is shown in Fig. 14. Aggressive burning behavior was observed on the un-compressed sample, while the compressed sample produced more uniform end burning behavior.

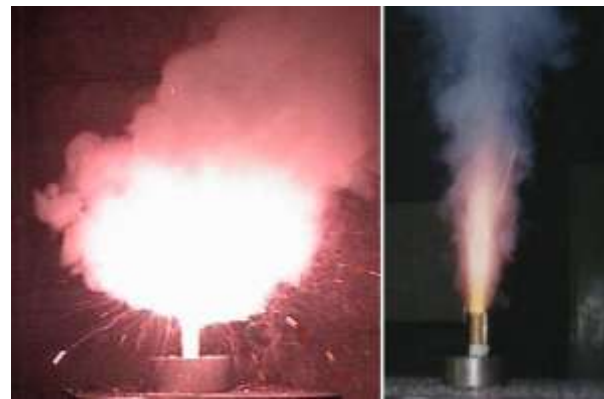

Figure 14 Burning behavior of uncompressed propellant sample (left) and compressed sample (right) ¹²

Stoichiometry formulation of the propellant mixture was determined using Traxel Labs, Inc.'s Propellant Evaluation Program (PEP). The stoichiometry formulation determined by PEP consists of 65 % Potassium Nitrate and 35 % of Sucrose. 5 static tests were done on the samples with various potassium nitrate/sucrose ratios and it was found that the stoichiometric formula produced the optimum thrust performance compared to the other four formulations in static test using convergent-divergent nozzle (Fig. 15 and Fig. 16)¹².



Figure 15 Static test at night time¹²

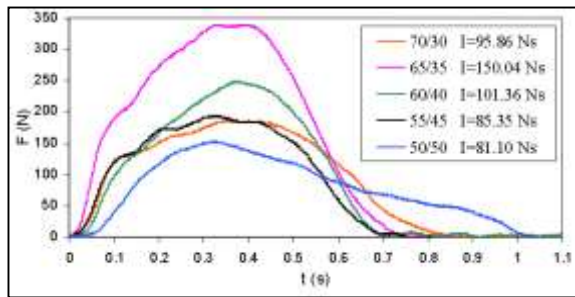

Figure 16 Thrust curves for various samples¹²

Numerical analysis of a rocket structure designed for cloud seeding activities was carried out by Mohamad Sukri¹³ in 2004. Rocket structures consist of three main components: (1) cylindrical body, (2) nose cone, (3) nozzle. They were analyzed with computational analysis MSC NASTRAN. Five different rocket nose configurations were studied at UTM open-loop subsonic wind-tunnel facilities¹⁴. Aerodynamic effects of these five nose configurations (Fig. 17) on rocket body were analyzed according to Dale L.B and Ernest E.N report (NACA RML53J06). It was found that the lift co-efficient C_L is increases as the angle of attack α is increased. At $\alpha=15^\circ$, hemisphere nose offered the lowest C_L value while the highest C_L value observed on the ogive nose configuration.

In 2005, airflow over a rocket body was studied at different Mach number ranging from subsonic to supersonic airflow and various angles of attack using analytical method¹⁵. The specifications of the designed rocket are shown in Table 6. Effect of compressibility in subsonic flow was not considered in the rocket body analysis while steady and non-rotational flow was assumed in the analysis using Computational Fluid Dynamics (CFD) software. Rocket model was simulated using 203202 cells with 43786 nodes for half configuration where the flow field assumed to be symmetric with respect to the mid-plane. FLUENT© Navier-Stokes solutions yield detailed flow features and good agreement with the calculated force and drag values. When the incident angle higher than 20 degree, Navier-Stokes

solutions produced substantial deviations in the analytical results as the flow field was assumed to be symmetrical and fully laminar or turbulent in the Spalart-Allmaras model.

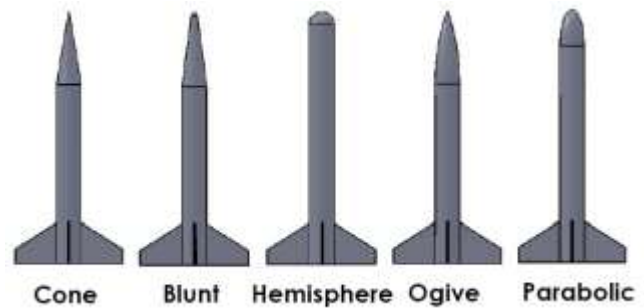

Figure 17 Nose configurations¹⁴

Table 6 Model Rocket Specification in Simulation¹⁵

Model rocket	9M-zetaGrip
Overall Length, L	4 m
Diameter, D	0.3676 m
Nose type	Conical
Nose length	1.1028 m
Afterbody length	2.7134 m
Fin cross section shape	Modified double wedge
Fin span	1.3236 m
Fin Area	0.5614 m ²
Fin Aspect Ratio	1.2450
Fin Thickness	0.0100 m
Fin Taper Ratio	0.4287
Boat-tail type	Conical
Boat-tail length	0.1838 m
Base Diameter	0.3481 m
Boat-tail angle	3.04 ⁰

The work of Rizalman Mamat¹² was further investigated in year 2006 where Polyethylene Glycol (PEG), Resin (Styrene 30 to 60 %, Polyester resin 30 to 60 %, additives 1 to 9 %) and Varnish lacquer (Isobutyl-Acetate 8%, Isobutyl-Alcohol 8%, Methyl-Ethyl-Ketone less than 5 %, Toluene 8 %, Xylene 8 %) were added to the propellant formulation as binder¹⁶. According to the computational analysis result, the stoichiometric formulation of the studied composite propellant without binder consists of 54 % potassium nitrate, 29 % aluminum powder and 17 % sulfur. Binder was then added to the stoichiometric formula at 20 %, 30 % and 40 % of total weight respectively to form the final propellant mixture. The changes in physical appearance and propellant burning behavior at various percentage of binder were observed in the experiment.

When the stoichiometric formula mixed with either kind of binder at 20 % of total weight, brittle product was formed in experiment, while bright yellow flame was observed in open air combustion process for all the samples (Fig. 18). Experimental data revealed that the burning rate of propellant grain was affected by the binder content percentage. Sample mixed with 40 % binder produces much slower burning rate compared to sample with 20 % and 30 % of binder¹⁶. Sample with 30 % of binder produces more desired results in term of sample workability and burning rates. Stoichiometric formulation had recorded an optimum burn-rate of 0.46 cm/s at atmospheric pressure.



Figure 18 Grain sample with 25% lekar composition (left) and the propellant burning behavior under atmospheric pressure (right) ¹⁶

Ammonium Nitrate based solid propellant was developed for academic research in 2005 ¹⁷. Ammonium Nitrate, sulfur and aluminum powder were mixed accordingly to the weight ratio presented in Table 7. It was found that the stoichiometric mixture consists of 55.4 % ammonium nitrate, 22.2 % sulfur and 22.4 % aluminum powder according to analytical method. Experimental data were shown that stoichiometric formulation has the optimum burning rate reading of 0.2045 cm/s under atmospheric pressure condition in strand burner test.

Table 7 Ammonium Nitrate Based Solid Propellant Formulation ¹⁷

Formulation	Ammonium Nitrate (% of total weight)	Sulfur (% of total weight)	Aluminum (% of total weight)
1	40	29	31
2	45	27	28
3	50	24	26
4	55	22	23
5	60	19	21
6	65	17	18
7	70	14	16
8	75	12	13

A new version of static thrust test station was designed by UTM researchers in year 2007 where dumbbell shaped load cell (Fig. 19) was introduced and tested in an academic research on Potassium Nitrate based propellant¹⁸. The load cell was made of aluminum alloy T-6062 with four set of 5mm strain gauges (RS632-168) connected to an oscilloscope (TEKTRONIX TDS3052). The signal from the strain gauges was calibrated for measurement up to 1000 N loading.



Figure 19 UTM-designed dumbbell shaped load cell (left) and load cell assembly in the static test station (right) ¹⁸

Carbon-based propellant and aluminum-based propellant were developed in UTM propellant lab in year 2007. These two kinds of propellants were tested in ballistic test with in-house designed

nozzles without thrust measurement (Fig. 20). It was found that the in-house designed nozzles able to withstand the hot gases produced by the 200gram propellant. Thus, the rocket motor was further evaluated with dynamic test (Fig. 21) ¹⁹. Although the researchers did not report any scientific value about the thrust produced by the designed rocket motor, the research team has successfully proven their ability in designing a safe and reliable experimental ballistic motor for future research in the institute.

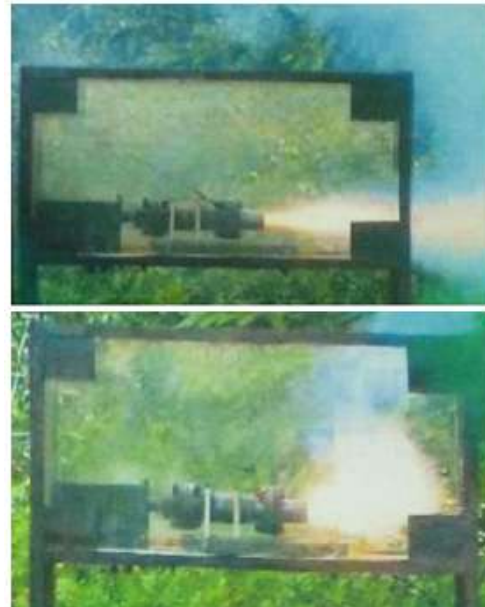

Figure 20 Nozzle tested with carbon-based propellant (top) and aluminum-based propellant (bottom)¹⁹



Figure 21 A rocket motor was on a rail for dynamic test¹⁹

Potassium nitrate based propellant became one of the major research activities in UTM propellant lab in year 2007 ^{20, 21}. Stoichiometric formula consists of 66.45 % Potassium Nitrate, 15.79 % Sulfur and 17.76 % Carbon was determined using CHEM computer software. A sample was prepared according to the stoichiometric formula followed by ignition test in open air condition (Fig. 22). Orange flame with sparks was observed during the burning process. Propellant strand with 10 mm diameter and 210 mm length was formed using Carbon, Sulfur and Potassium Nitrate for burn-rate test. Burn-rate of seven different compositions (Table 8) was observed using strand burner test under open air condition (Fig. 23). The element of sulfur remains at 15.79 % of total weight for all the composition and

varnish lacquer was used as binder for the mixture. Brittle sample was formed in formulation 1 and 2 with high percentage of carbon element. Thus, these two formulations were taken out from burn rate test. According to the experimental data, formulation No. 4 produced the highest burn rates of 0.2734 cm/s compared to others. The study deduced that stoichiometric formulation was critical in producing the optimum burn-rate of solid propellant.

Table 8 Potassium based propellant with 7 different chemical compositions and burn rate values ²⁰

Propellant No	Chemical composition (% by mass)				Burn rates cm/s
	Potassium Nitrate	Sulfur	Carbon	Varnish	
1	60.45	15.79	23.76	22	-
2	62.45	15.79	21.76	22	-
3	64.45	15.79	19.76	22	0.2203
4	66.45	15.79	17.76	22	0.2734
5	68.45	15.79	15.76	22	0.1994
6	69.45	15.79	13.76	22	0.1408
7	70.45	15.79	11.76	22	0.1252



Figure 22 Burning of a potassium nitrate based propellant ²⁰



Figure 23 Burn rate test rig for solid propellant ²¹

In order to investigate the relationship between burning rate r of a propellant and pressure in combustion chamber P_c , a UTM-designed pressurized burn-rate test rig (Fig. 24) was used to

obtain the burn-rate coefficient a and pressure exponent n of the following burn-rate equation ²².

$$r = aP_c^n \quad (1)$$

Critical area on the burn-rate test rig structure under applied pressure was analyzed using Nastran-Patran Computational method. Burn rate of Potassium Nitrate based propellant samples were measured at combustion chamber pressure of 2 bar and 4 bar. Experimental results indicate that the burn-rate coefficient $a=1.397 \times 10^{-3}$ and pressure exponent $n=0.5216$.



Figure 24 UTM-designed Pressurised Burn Rate Test Rig ²²

A model rocket UTM-X1 was designed for surveillance operation in year 2007 and its aerodynamic characteristic was analyzed using UTM low speed wind tunnel (Fig. 25). The specifications of UTM-X1 are given in Table 9. Data collected through computational method using U.S.A.F. Datcom and CFD software was verified with experimental data from low speed wind tunnel testing. Model rocket made of fiber glass composite material was tested at wind speed of 40 m/s to 70 m/s at angle of attack up to 30degree. Riza²³ found that Coefficient of lift C_L of UTM-X1 increased almost linearly to the angle of attack component, while the coefficient of drag C_D reacts differently for varies of wind speed at angle of attack larger than 15degrees.

Table 9 Specification of Model Rocket UTM-X1 ²³

Model rocket	UTM-X1
Overall Length, L	1050 mm
Diameter, D	70mm
Nose type	Conical
Nose length	198.49mm
Afterbody length	718.51mm
Fin cross section shape	Modified double wedge
Fin span	190mm
Fin Area	16800 mm ²
Fin Aspect Ratio	1.1828
Fin Thickness	2mm
Fin Taper Ratio	0.4286
Boat-tail type	Conical
Boat-tail length	35mm
Base Diameter	63.88mm
Boat-tail angle	5°



Figure 25 Model Rocket UTM-X1 inside the UTM Low Speed Wind Tunnel ²³

At the same period of time, UTM research team has developed a numerical model using Datcom method to predict the aerodynamic characteristics of a rocket. The computer program is capable of generating aerodynamic characteristics data up to an angle of attack below 25 degree at operational speed up to Mach number 3. The numerical data showed a maximum error of 10% compared to available published work cited in the report. Input parameters such as the designed geometry, location for the center of gravity and operational speed were required to obtain the output data in term of coefficient of lift, coefficient of drag, coefficient of momentum and center of pressure measured from nose tip. The limitations of the developed program are listed below: ²⁴

- Operational speed lower than Mach number of 3.
- Ratio of wing span to tail span lower than 1.5.
- Ratio of body diameter to wing span lower than 0.8.
- Suitable for rocket body with straight tapered wing and tail configuration.
- Suitable for airfoil profile using NACA0003, NACA0006 and NACA0009.
- Applicable only for symmetrical double wedge and bi-convex airfoil.
- Rocket tail will be treated as wing for rocket without wing.
- Analysis is limited to angle of attack of 25 degree at supersonic speed.
- Material surface roughness assumed as well polished metal surface.

Alwi²⁵ developed an effective fabrication technique using composite material for rocket body in 2008 . Chopped strand matted (CSM) typed fiberglass was chosen as raw material for their specific strength and stiffness compared to the typical carbon fiber. Patty sealing process (Fig. 26) was introduced by Alwi ²⁵ to seal the holes on surface of the cured rocket body. It is a process where a layer of fine cement is applied onto the cured composite rocket body before sanding with sand paper grade. A layer of paint was sprayed on the polished surface. This process was repeated twice to achieve a smooth rocket body surface. The rocket body was fabricated based on CRV-7 missile specification and computational method was used to analyze the rocket body aerodynamic characteristic.



Figure 26 Patty sealing process on rocket body (left) and assembly of rocket body (right) ²⁵

In order to conduct small scale static test on rocket motor at remote place, a research project on design and fabricate a rocket motor testing cradle was initiated in year 2008 ²⁶. The cradle (Fig. 27) consists of a load cell with two strain gauges RS632-168, rocket motor holder with trolley and a flat steel table with two railways. Finite Element software (NASTRAN 4.5) was used to analyze static stress distribution on the mild steel load cell under applied force up to 2000 N. Thrust force produced by rocket motor was transferred to the load cell, while the electric voltage differences in the load cell were further processed and recorded by computer.



Figure 27 Rocket motor testing cradle ²⁶

The cradle mentioned above was used for thrust measurement of a rocket motor. A new type of solid propellant was developed in the same period of time. Nitrocellulose was used as binder in the solid propellant formulation in 2008 ^{27, 28}. Nitrocellulose was produced using 25.4 ml Sulfuric Acid, 26.9 ml Nitric Acid, 5 grams Cotton, 500 ml Sodium Bicarbonate and 2 liter of water. ²⁷ 16.5 % (in total weight) Nitrocellulose was mixed with 64.0 % Potassium Nitrate, 12.0 % Carbon and 7.5 % Sulfur to form the experimental composite propellant (Fig. 28). Three hollow cylindrical propellants were fabricated for firing test and each one of them weighted 110g , 167 g and 330 g. Static test with a ballistic experimental motor (BEM) was recorded with video camera (Fig. 29) and thrust measurement system. Although the thrust measurement system didn't worked as desired, the in-house designed BEM was able to withstand the combustion pressure and combustion heat for the entire experiment. Bright light was observed behind the nozzle during the combustion process ²⁸.

Three grain configurations (Fig. 30) were studied in the same period of time. These solid propellant grains consist of 66.45 % Potassium Nitrate, 17.76 % Sulfur and 15.79 % Carbon. Strand burner samples with 100 mm length and 25 mm diameter were fabricated for burn rate test at atmospheric pressure. It was found that the star shape configuration given the highest burn rates at 25.37 mm/s, followed by tubular shaped grain with 8.25 mm/s and end burner shaped grain with 2.92 mm/s²⁹.



Figure 28 A propellant grain sample after cured for 3 days²⁸



Figure 29 Firing test of solid propellant.²⁸
 a) Ignition stage b) Propellant A (110grams) at 5 seconds
 c) Propellant B (167grams) at 6.5 seconds
 d) Propellant C (330grams) at 4 seconds.



Figure 30 Grain configurations consist of tubular, star and end burner²⁹

Propanone (also known as acetone) is an organic compound that commonly used as solvent in laboratory was mixed with Potassium Nitrate, Sulfur, Carbon and Varnish to form an experimental solid propellant in year 2008³⁰. The composite propellant grain consists of 85.84 g Potassium Nitrate, 11.44 g Sulfur, 17.46 g Carbon, 25.30 g Varnish and 5.00 g Acetone. Solid propellant grain with 40 mm diameter and 80 mm length was fabricated and fitted inside an in-house designed BEM for static test as it is shown in Fig. 31. Aggressive burning behavior was observed in the static test where the low carbon steel BEM was destroyed by the high combustion pressure.



Figure 31 Potassium Nitrate based solid propellant in static test³⁰

Heat produced by the solid propellant during combustion process became one of the research interests in UTM propulsion lab, thus a simple temperature measurement apparatus using K-type thermocouple was developed in the same year. K-type thermocouple used in the experiment was able to operate up to 1400°C. However, it was reported that the thermocouple melted in the combustion process of the Potassium Nitrate based propellant. This observation shows that the combustion temperature has reached more than 1400°C³¹.

A prototype of a solid propellant extruder was build in 2008 with the capability to extrude a product with 10mm diameter at the speed of 3.66 mm/s³². Taper parallel screw method was incorporated into the machine design. The extruder consists of a polyethylene (PE) plastic extrusion screw and a stainless steel barrel (Fig. 32). A modeling clay known as plasticine was used to simulate solid propellant in the experiment. The specifications of the prototype are given in Table 10.

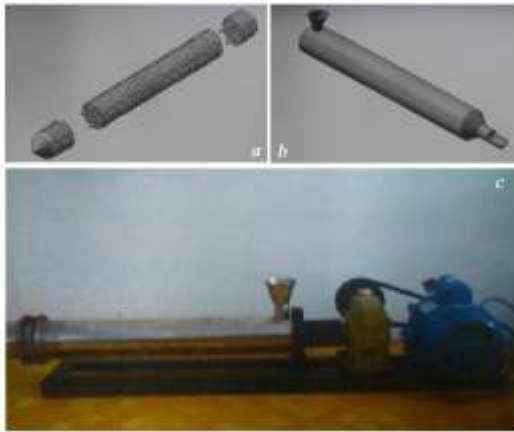

Figure 32 Prototype of a solid propellant extruder machine
a) Extrusion screw assembly; b) Extruder barrel; c) Complete system ³²

Table 10 The specifications of solid propellant extruder ³²

Extrusion screw	
Diameter	100 mm
Channel depth	5 mm
Pitch	50 mm
Flight width	10 mm
Flight clearance	0.1 mm
Rotation speed	35 rpm
Helix angle	18°
Extruder barrel	
Outer diameter	120 mm
Overall length	880 mm

The Potassium Nitrate study was continued in 2009 by Aliff. The relationship between the percentage of Nitrocellulose in the propellant mixture and the propellant burn rates was studied using strand burn test. The propellant was dried at 60°C for 24 hours before ground in a grinder for 150 mins. The ground product was sieved using standard sieve size of 212 µm. The strand samples were prepared according to the formulation presented in Table 11 and these samples were tested in strand burn test to obtain their burn rates data ³³.

Academic research on AP-based solid propellant with polybutadiene binder was initiated in year 2009 ^{34,35}. A six

hundred grams solid propellant consists of 66 % AP, 13 % Al, 21 % HTPB binder and 0.69 % Isophorone diisocyanate (IPDI) as curing agent was prepared for firing test using a BEM (Fig. 33). However, it was reported that the firing test was not successfully done due to structure failure at BEM steel casing. Steel bolts that secured the casing and nozzle experienced structural failure due to design error and high combustion pressure ³⁴.



Figure 33 Experimental ballistic motor (left) and ballistic motor in static test (right) ³⁴

A Crawford bomb (Fig. 34) for propellant burn rate test was designed and fabricated by UTM researchers. Thirteen sets of AP based propellant strand samples (Table 12) were prepared for the burn rate test at atmospheric pressure, while five sets were chosen for burn rate test at 65 Psi and 110Psi ³⁵. It was found that the burn rate increased with the increasing of AP amount within the propellant, while the aluminum powder seems has no effect on the propellant burn rates. Five sets of the empirical constant and pressure exponent were successfully obtained through this experiment.



Figure 34 A UTM-designed Crawford bomb for burn rate test ³⁵

Table 11 Composition of propellant samples and their burn rates at various pressures ³³

Sample No.	Percentage of Nitrocellulose (% in 50g of sample)	Mass of Nitrocellulose, g	Mass of Potassium nitrate, g	Mass of Carbon, g	Mass of Sulfur, g	Average burn rates at 15 Psi (1atm), mm/s	Average burn rates at 30 Psi, mm/s
1	30.0	15.00	31.10	3.08	0.82	-	-
2	25.0	12.50	33.32	3.30	0.88	1.79	-
3	22.5	-	-	-	-	2.76	15.27
4	20.0	10.00	35.54	3.52	0.94	6.20	22.16
5	17.5	-	-	-	-	4.18	-
6	15.0	7.50	37.76	3.74	1.00	5.14	-
7	10.0	5.00	39.98	3.96	1.06	-	-

Table 12 Propellant composition and burn rates³⁵

Sample no.	Composition (% by mass)				Burn rates (mm/s)			Experimental data	
	AP	AL	HTPB	IPDI	At 14.7 Psi	At 65 Psi	At 110 Psi	Coefficient, a	Pressure Exponent, n
1	62	25	13	0.94	2.13	-	-	-	-
2	64	23	13	0.94	2.86	-	-	-	-
3	66	21	13	0.94	2.75	7.69	12.67	0.90	1.318
4	68	19	13	0.94	2.81	-	-	-	-
5	70	17	13	0.94	3.30	10.33	25.30	0.95	0.987
6	72	15	13	0.94	3.58	-	-	-	-
7	74	13	13	0.94	4.37	-	-	-	-
8	76	11	13	0.94	3.52	24.63	21.49	1.21	1.112
9	78	9	13	0.94	4.04	21.46	25.69	1.20	1.088
10	80	7	13	0.94	4.26	13.35	25.21	1.30	1.132
11	82	5	13	0.94	4.64	-	-	-	-
12	84	3	13	0.94	4.33	-	-	-	-
13	86	1	13	0.94	4.34	-	-	-	-

An automated computer program namely OPTIMUMIX was developed by Feizal³⁶ to determine the optimum mixture ratio for liquid propellant rocket engine using nitrogen tetroxide and monomethyl hydrazine. Conceptual design of the rocket engine is shown in Fig. 35. Bell shaped nozzle was chosen instead of conical due to the mission requirements. Nozzle contour was determined with Rao's³⁷ nozzle contour optimization method. Combustion chamber was made of Nimonic 90, while the exhaust nozzle was made of Columbium C-103. Combustion chamber of the rocket engine was designed with semi-empirical method by fixing the oxidizer to fuel ratio at the value of 1.69. Specification of the designed rocket engine was comparable to commercial HiPAT engine. This preliminary design was the first step in developing a liquid propellant rocket engine for upper stage application in UTM research history.

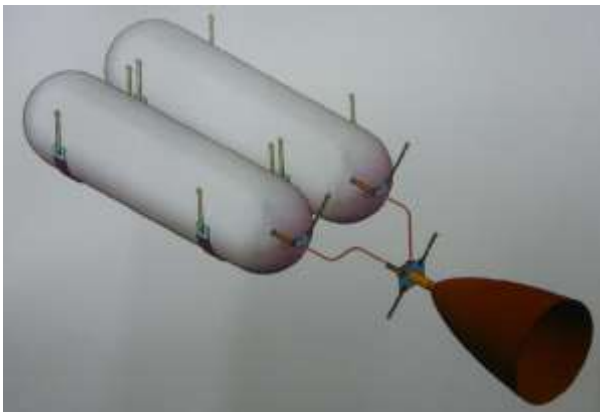
**Figure 35** Conceptual design of nitrogen tetroxide/monomethyl hydrazine liquid propellant rocket engine³⁶

Designing a conceptual liquid rocket engine for upper stage applications continue to receive interest among UTM researchers in year 2010 where the RD-58M rocket engine was chosen as reference for their design³⁸. A conceptual liquid rocket engine using hydrogen peroxide and kerosene (Fig. 36) which capable of producing 85 kN thrust force for a period of 700s was developed using computer software (NASA CEC-71). The bell shape nozzle contour was designed using parabolic approximation procedure.

The bell shaped nozzle has an exhaust diameter of 1.13 m with nozzle area ratio of 190 that operates under combustion pressure of 8 MPa. The hydrogen peroxide was stored in the 12.38

m cylinder shaped oxidizer tank, while the kerosene was stored in the 1.8 m spherical shaped fuel tank. The fuel and oxidizer were mixed and burned at combustion chamber, designed to generate the ideal specific thrust of 3306.1 Ns/kg.

**Figure 36** Conceptual design of hydrogen peroxide/kerosene liquid rocket engine³⁸

An effective method to produce rocket grade hydrogen peroxide with 85 % concentration at lab scale level was studied by Kuberaaraj in 2010³⁹. Two methods were used in the hydrogen peroxide preparation and the final product was then characterized with pH test and Inductively Coupled Plasma Mass Spectrometry (IC-PMS) machine. First method started by heating 1 liter of lab reagent grade hydrogen peroxide (35 % concentration with pH value of 2.12) on hot plate at atmospheric pressure. (Fig. 37) The solution was maintained at 55 to 60^oC for 18 hours until the solution volume reduced to 250cc or 30% of the original volume. The experimental data that is shown in Table 13 deduced a maximum value of volume concentration at 0.807 was achieved with this approach. Mass concentration C_m and volume concentration C_v were determined with the following relationships, where volume denoted as V and mass denoted as m .

$$C_v = \frac{V_{Hydrogen\ peroxide}}{V_{Hydrogen\ peroxide} + V_{water}} \quad (2)$$

$$C_m = \frac{m_{Hydrogen\ peroxide}}{m_{Hydrogen\ peroxide} + m_{water}} \quad (3)$$



Figure 37 Heating process with hot plate at atmospheric pressure (left) and boiling process with rotary evaporator (right) ³⁹

Table 13 Experimental data of atmospheric pressure boiling method ³⁹

Solution batch	Initial solution volume (ml)	Final solution volume (ml)	Hydrometer reading (g/cc)	Solution mass concentration, C_m	Solution volume concentration, C_v	pH value
1	600	171	1.295	0.774	0.704	-
2	600	190	1.295	0.788	0.721	0.46
3	600	197	1.305	0.807	0.744	-

Table 14 Experimental data of rotary evaporator method ³⁹

Solution batch	Initial volume in boiling flask (ml)	Final volume in boiling flask (ml)	Boiling Temperature ($^{\circ}$ C)	Hydrometer reading (g/cc)	Solution mass concentration, C_m	Solution volume concentration, C_v
1	600	182	60 - 88	1.370	0.891	0.850
2	600	148	65	1.374	0.915	0.882
3	600	180	60 - 88	1.355	0.887	0.845
4	600	145	65	1.383	0.928	0.900
5	600	172	60 - 88	1.362	0.889	0.845
6	600	168	65	1.353	0.887	0.845

Rotary evaporator method was used as the second approach for preparing the product. The solution in the boiling flask experienced rapid evaporation at 60 $^{\circ}$ C in water bath for 3 to 4 hours. Density of the concentrated product was measured with floating glass hydrometer. Experimental results (Table 14) show that the product with 90 % concentration can be achieved effectively with the solution remains at 65 $^{\circ}$ C. It was found that the product is extremely acidic where the pH value of zero was measured in the experiment ³⁹. Thus, the second approach was proposed as effective way in producing rocket grade hydrogen peroxide at lab scale.

There was another highlight in UTM research history where an experimental binder using natural rubber ⁴⁰ was studied in year 2010. Liquid rubber solution was prepared by mixing the natural rubber (standard Malaysian rubber grade L-typed) with toluene, hydrogen peroxide, ethanol, methanol, benzophenone and acetone. Hydroxyl-Terminated Natural Rubber (HTNR) was formed in the depolymerisation process through photochemical reaction using Ultraviolet (UV) lights. Liquid rubber solution experienced color changes from orange to milky white during depolymerisation process (Fig. 38). Burning rates for six different compositions (Table 15) were tested in this research and the experimental data shown that natural rubber samples have burn faster than HTPB samples. Burning behavior between the samples was recorded with camera (Fig. 39).



Figure 38 Depolymerisation process on HTNR sample (from top: 0 hours, 200hours and 400hours) ⁴⁰

Table 15 Propellant compositions ⁴⁰

Sample	Composition of propellant sample (in grams)				
	AP	Al	HTPB	IPDI	NR
1	33	9.5	7.5	-	-
2	33	7.0	10	-	-
3	33	9.5	7.5	0.7	-
4	33	9.5	-	-	7.5
5	33	7.0	-	-	10
6	33	9.5	-	0.7	7.5



Figure 39 Firing test on sample with natural rubber (left) and with HTPB (right) ⁴⁰

Fireclay is a known refractory ceramic that can withstand high temperature without experiencing melting or decomposing process. It is discovered that fireclay was able to protect the rocket casing from high temperature during firing process. Two kind of ceramic composition were developed and their thermal conductivity was determined in the research (Table 16). It was found that sample mixed water and Polyvinyl Acetate (PVA) offers lower thermal conductivity value than the sample mixed only with water. Thus, the ceramic insulator was made from combination of fireclay, water and PVA. The ceramic insulator was then installed in the combustion chamber and evaluated in a firing test (Fig. 40). It also found that the ceramic combustion chamber react as a good insulator for the rocket motor during the firing test with AP based solid propellant ⁴¹.

Table 16 Thermal conductivity of ceramic samples ⁴¹

Composition	Sintering Temperature °C	Thermal Conductivity k (steady state), W/mK
Fireclay with water	400	262.40
	800	240.33
Fireclay with water and Polyvinyl Acetate (PVA)	400	176.83
	800	168.74



Figure 40 Ceramic insulator (left) and static test at nozzle exhaust (right) ⁴¹

The successful evaluation in the ceramic insulator experiment has motivated the research team to further study the possibilities of using fireclay in rocket nozzle fabrication. Samples with three different fireclay grain sizes (Table 17) were fabricated and evaluated with Instron 8801 universal fatigue testing machine. Fireclay to water ratio was fixed at 2:1 for all sample. It was

found that Modulus Young increases as the grain size decreases. Thus, 150 μ m grain size fireclay was used for nozzle fabrication ⁴².

Table 17 Compression test on sample with various grain sizes ⁴²

Sample No.	Fireclay grain size (μ m)	Modulus Young, E (MPa)	Maximum Yield Stress, (MPa)
1- 6	300	92.25	1.00
21-23	212	146.87	1.38
11-13	150	314.55	1.90

An in-house designed mold coated with CilRelease® was used to form the shape of nozzle. Fireclay mixture was formed under compression pressure of 100Psi and dried at room temperature for 3 days before treated at 950 °C in furnace with heating rate of 5 °C/min. Although the fireclay was known melting at 1400 °C, the heating process was limited by the furnace maximum operational temperature at 950 °C. It was found that the sample losses 30 % of initial weight and experienced 5 % shrinkage of original size during sintering process. The nozzle sample (Fig. 41) was then stored at room temperature and tested in firing test using BEM filled with aluminum based propellant. The nozzle survived the 7 second combustion process and stayed intact with the BEM. Thus, the fireclay has shown it potential in rocket application.



Figure 41 Ceramic nozzle developed in year 2011 ⁴²

Detail investigation on AP based composite solid propellant ballistic properties using in-house build closed Crawford bomb facility were successfully done in year 2011. The composite propellant consists of AP, Al, HTPB and IPDI⁴³. A lab-scale Crawford bomb facility (Fig. 42) consists of cylindrical shape metal case with pressure gauge and safety valve. Solid propellant strand with 6mm diameter and 80 mm length was placed on the holder. Burn rate was calculated from the period of time taken by the hot frame to travel across a predefined distance on the strand samples. Nitrogen gas was filled inside the combustion chamber and act as inert gas throughout the experiment. Thirteen formulations were studied in the Crawford bomb facility and their average burn rates at atmospheric pressure were presented in Table 18. According to the experimental data, the oxidizer to fuel ratio (O/F) was a factor affecting the burn rate where the burn rate of the propellant increased with the O/F ratio.

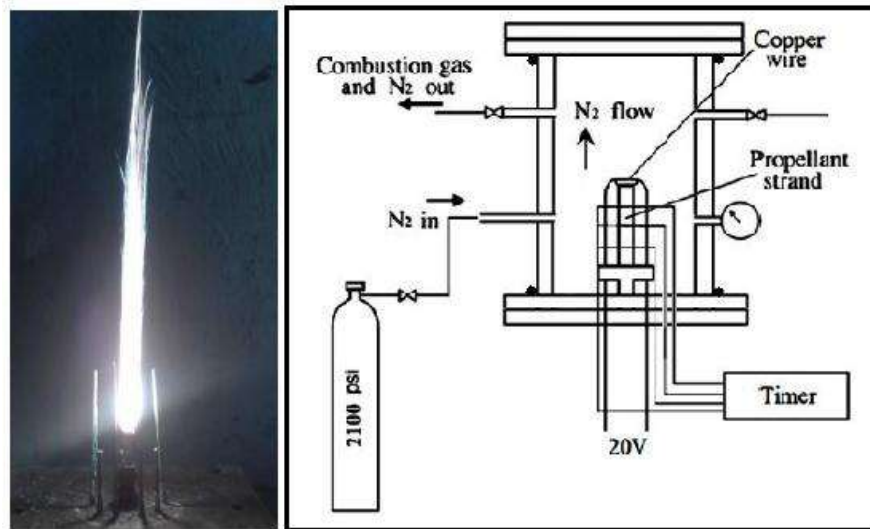

Figure 42 Burning of a propellant strand (left) and schematic diagram of burn rates test (right) ⁴³

Table 18 Thirteen formulations and their average burn rates ⁴³

Formulation	AP (%)	Al (%)	O/F ratio	Average burn rates at 1atm pressure (mm/s)
P80	80	5	4.00	1.776
P78	78	7	3.55	1.860
P76	76	9	3.16	1.670
P74	74	11	2.85	1.630
P73	73	12	2.70	1.680
P72	72	13	2.75	1.670
P71	71	14	2.45	1.580
P70	70	15	2.33	1.700
P68	68	17	2.13	1.580
P66	66	19	1.94	1.565
P64	64	21	1.78	1.590
P63	63	22	1.70	1.560
P60	60	25	1.50	1.527

Table 19 Average burn rates of four selected propellant at various pressure ⁴³

Formulation	Burn rates at various pressure					Empirical Constant, a	Pressure exponent, n
	Chamber Pressure 1 atm	Chamber Pressure 6 atm	Chamber Pressure 11atm	Chamber Pressure 21 atm	Chamber Pressure 31 atm		
P80	1.776	3.959	6.684	10.045	11.991	1.687	0.561
P74	1.630	3.790	6.113	9.520	10.749	1.578	0.554
P66	1.565	3.370	5.343	8.249	9.944	1.466	0.545
P60	1.527	3.260	4.610	7.327	8.425	1.455	0.501

Four formulations from Table 18 were chosen for burn rate test under varies pressure condition. They are the P80, P74, P66 and P60. The propellant with P80 has shown the highest burn rate value compared to others for all the combustion pressure condition. Empirical constant a and pressure exponent n of each propellant were determined from experimental data (Table 19). The relationship between propellant formulation and combustion pressure was recorded for the first time in UTM academic research history. Although P80 formulation shows more promising performance in term of burn rate, solid propellant with P66 formulation was selected as research subject in the static

thrust test. The P66 formulation was capable of producing better specific impulse value compare to the rest.

A cylindrical shaped propellant grain with 56.4mm outer diameter and 30.0mm port diameter was fabricated using compressed mold method. The 456 grams propellant grain with body length of 194.0mm was tested with BEM in a static thrust test (Fig. 43). Table 20 shows the ballistic performance of the P66 formulation in the BEM with expansion ratio of 1.44.

Table 20 Ballistic performance of a P66 propellant based on nozzle with throat diameter of 25mm⁴³

Parameter	Symbol and unit	Theoretical value	Experimental value
Specific impulse	I_{sp} , s	173.21	143.92
Average thrust	F_{avg} , N	283.68	189.35
Total impulse	I_{total} , N.s	774.83	643.79
Burning time	t_b , s	2.73	3.40
Burning rates	r , mm/s	4.83	3.88
Chamber pressure	P_c , Psia	1.565	1.466
Mass flow rate	M , kg/s	0.167	0.134
Exhaust velocity	v_o , m/s	1699.2	1411.86
Thrust coefficient	C_F	0.968	0.647

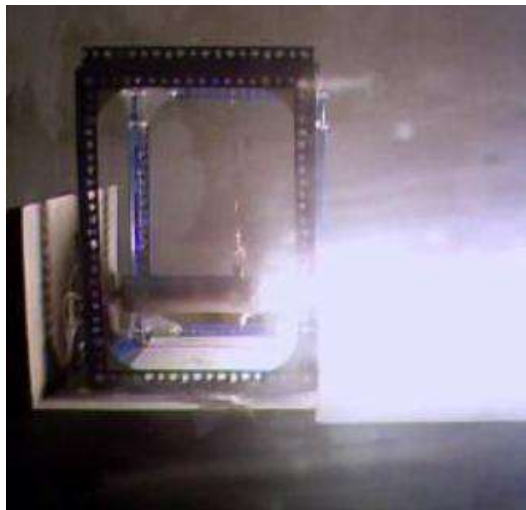
**Figure 43** Static test on AP based solid propellant⁴³

Hydrogen peroxide monopropellant rocket thruster capable of producing 50N thrust force for space application was successfully developed in UTM propellant lab in 2011⁴⁴. Thirty sets of hot test were successfully conducted throughout the experiment by varying catalyst pack compression pressure (6 MPa and 9.29 MPa), injector diameter (0.602mm, 1.045mm, 1.367mm and 2.011mm), nozzle throat diameter (3.588mm and 4.574mm) and injector pressure (around 37bar and 29bar). According to the experimental data, the desired 50N thrust force was achieved with the efficiency of hydrogen peroxide decomposition η_{c*} close to 0.90 by setting the injector diameter at 1.045 mm, nozzle throat diameter of 4.574 mm, catalyst pack compression pressure at 9.29 MPa and injection pressure at 37bar.

Hydrogen peroxide with concentration more than 90% was used as monopropellant for the rocket thruster. The thruster assembly was presented in Fig. 44. 40 mesh silver screen (99% impurity) supplied by King De Long wire mesh (Shijiazhuang) company in China was used to form the 50mm length catalyst pack. The 200 pieces of circular shaped silver screen need to be pickled in nitric acid (10% concentration) to remove contamination on the samples and washed with samarium nitrate solution (4% concentration) to enhance the catalyst effect in the thruster⁴⁴.

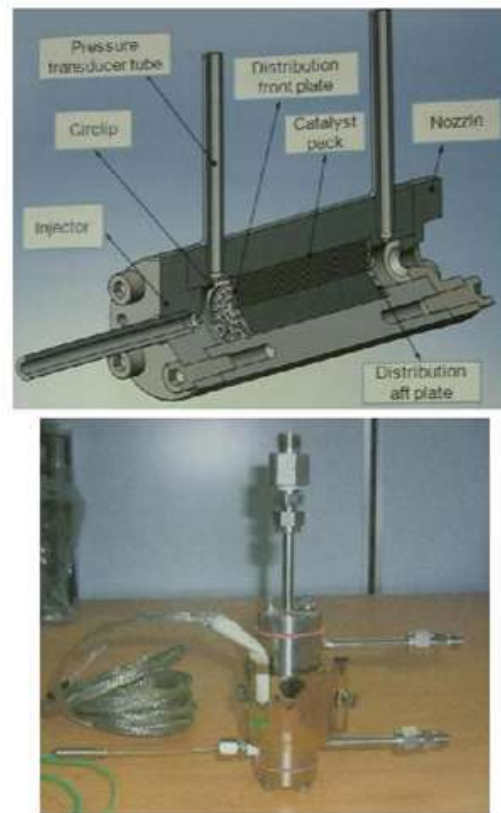
**Figure 44** Cross-sectional view of the rocket thruster (top) and rocket thruster (bottom)⁴⁴

4.0 CONCLUSION

A total of 41 closed access academic theses and project papers in the UTM library achieve were selected for this review work. A brief history insight on the research activities related to rocket in UTM was covered extensively from year 1992 to 2011. The research team has developed a strong foundation in term of rocket motor design and rocket propellant fabrication methodologies. Some of the significant findings reported in this paper can be a valuable reference for other research institutions that involved with rocket technologies, while achieving a global understanding in the UTM rocket research history.

Acknowledgement

The study was conducted under UTM-PHD Zamalah Scholarship and financial support under collaboration project (program pembangunan teknologi rocket VOT68730) between Universiti Teknologi Malaysia, Ministry of Science Technology and Innovation (MOSTI) and Ministry of Higher Education of Malaysia.

References

- [1] Universiti Teknologi Malaysia Official website [Online]. Available: < http://www.utm.my/about/brief-history-of-utm/> [accessed 31Jan2013].
- [2] Wan Khairuddin Wan Ali, Mohammad Nazri Mohd. Jaafar, Ainullofti Abdul-Latif, Md. Nizam Dahalan, Abd Basid Abd Rahman, Zuriana Mariati Mat Yajid et al. *Development indigenous rocket motor A UTM experience*. UTM research paper series.
- [3] Van Ripe, A. Bowdoin. 2004. *Rocket And Missiles: The Life Story Of A Technology*. Greenwood Press.
- [4] Kandiah Padmanathan. 1992. *Design Of An 60 Newton Rocket Motor*. Bachelor degree Thesis. Universiti Teknologi Malaysia.
- [5] Liew Shuang Chen. 1994. *A Design Of Rocket Motor Static Test Rig Together With Parameter Transducer*. Bachelor degree Thesis. Universiti Teknologi Malaysia.
- [6] Mu, Cher Liang. 1994. *A Design Of Testing Rocket Motor*. Bachelor degree Thesis. Universiti Teknologi Malaysia.
- [7] Wan Sazlina Abu Bakar. 1994. *Analisa Tegasan Ke Atas Bekas Tekanan*. Bachelor degree Thesis. Universiti Teknologi Malaysia.
- [8] Arman Daut. 1994. *Fabrikasi Model Peluru Kris-13 Tanpa Pandu Permukaan Ke Udara*. Bachelor degree Thesis. Universiti Teknologi Malaysia.
- [9] Wong Khay Chin. 1996. *Ceramic Nozzle*. Bachelor degree Thesis. Universiti Teknologi Malaysia.
- [10] Rizalman Mamat. 1999. *Merekabentuk Dan Menguji Sebuah Motor Rocket Kecil Yang Menghasilkan Tujah 1kN*. Bachelor degree Thesis. Universiti Teknologi Malaysia.
- [11] Khairul Ayob. 1999. *Pelancar Kawalan Computer Mikro*. Bachelor degree Thesis. Akademi Terentara Malaysia, Universiti Teknologi Malaysia.
- [12] Rizalman Mamat. 2002. *Ciri-Ciri Propellan Roket Pepejal Berasaskan Kalium (Characteristic Of Kalium Based Solid Rocket Propellant)*. Master degree Thesis. Universiti Teknologi Malaysia.
- [13] Wan Ikmal Harris Hasbi. 2004. *Rekabentuk Struktur Roket (Rocket Structure Design)*. Bachelor degree Thesis. Universiti Teknologi Malaysia.
- [14] Mohamad Sukri Mat Ali. 2004. *Merekabentuk Dan Membina Sebuah Model Roket Untuk Pengujian Terowong Angin (Design And Fabrication Of A Model Rocket For Wind Tunnel Testing)*. Bachelor degree Thesis. Universiti Teknologi Malaysia.
- [15] Seok, Wye Kay. 2005. *Aerodynamic Study of Flow Over Rocket Body*. Bachelor degree Thesis. Universiti Teknologi Malaysia.
- [16] Ahamd Saufi Mohamad Zahri. 2006. *Mereka Bentuk Propelan Pepejal Untuk Roket Kecil (Develop A Solid Propellant For Small Rocket)*. Bachelor degree Thesis. Universiti Teknologi Malaysia.
- [17] Shah Rizal Ruslan. 2006. *Membangunkan Bahan Dorong Ammonium Nitrate Sebagai Bahan Dorong Roket Pepejal (Development Of Ammonium Nitrate Based Solid Rocket Propellant)*. Bachelor degree Thesis. Universiti Teknologi Malaysia.
- [18] Mohd Effendi Abd. Ghani. 2007. *To Design A Rocket Static Test Rig*. Bachelor degree Thesis. Universiti Teknologi Malaysia.
- [19] Raffirul Hanif Ramli. 2007. *Rekabentuk Nozel Untuk Motor Roket (Nozel Design For Rocket Motor)*. Bachelor degree Thesis. Universiti Teknologi Malaysia.
- [20] Mohd Zaki Yamani Rahmat. 2007. *Membangunkan Bahan Dorongan Untuk Roket Pepejal (Development Of Solid Rocket Propellant)*. Bachelor degree Thesis. Universiti Teknologi Malaysia.
- [21] Intan Noryanah Kimsin. 2007. *Development of A Burning Rate Test Rig for Solid Propellant*. Bachelor degree Thesis. Universiti Teknologi Malaysia.
- [22] Nasrulrahim Musa. 2007. *Development of Pressurised Burning Rate Test Rig For Solid Propellant*. Bachelor degree Thesis. Universiti Teknologi Malaysia.
- [23] Muhammad Riza Abd. Rahman. 2007. *Wind Tunnel Test on UTM-X1 Rocket Body*. Bachelor degree Thesis. Universiti Teknologi Malaysia.
- [24] Su Vin Cent, Tai Vin Cent. 2007. *Development of Computer Software on Rocket Aerodynamic Characteristic Estimation*. Bachelor degree Thesis. Universiti Teknologi Malaysia.
- [25] Alwi Bin Amad. 2008. *Design And Fabrication Of Rocet Body Using Composite Material*. Bachelor degree Thesis. Universiti Teknologi Malaysia.
- [26] Adly Kalam. 2008. *Development Of Rocket Motor Testing Cradle*. Bachelor degree Thesis. Universiti Teknologi Malaysia.
- [27] Mohd. Qayyam Omar. 2008. *To Develop Solid Propellant Based On KNO₃ With Carbon Mixture*. Bachelor degree Thesis. Universiti Teknologi Malaysia.
- [28] Amir Aziz. 2008. *A Development Of 500N Thrust Rocket Motor Using KNO₃ Carbon Propellant*. Bachelor degree Thesis. Universiti Teknologi Malaysia.
- [29] Mohd. Muzamul Wahab. 2008. *Study On The Influence Of Grain Shape On Solid Propellant Performance*. Bachelor degree Thesis. Universiti Teknologi Malaysia.
- [30] Mohd Rozi bin Mohd Perang. 2008. *A Development Of 100N Thrust Rocket Motor Using KNO₃-Carbon Propellant*. Bachelor degree Thesis. Universiti Teknologi Malaysia.
- [31] Mohd Zaki Abdul Manaf. 2008. *Development Of Data Acquisition System For Propulsion Laboratory*. Bachelor degree Thesis. Universiti Teknologi Malaysia.
- [32] Annar Ahmad Salar. 2008. *Development Of Propellant Extruder*. Bachelor degree Thesis. Universiti Teknologi Malaysia.
- [33] Mohd. Aliff Hafifi bin Abdullah. 2009. *Development Of Nitrocellulose Base Propellant*. Bachelor degree Thesis. Universiti Teknologi Malaysia.
- [34] Mastura Binti Ab.Wahid. 2009. *Design And Fabrication Of A 200N Thrust Rocket Motor Based On Ammonium Perchlorate+Aluminum As Solid Propellant*. Bachelor degree Thesis. Universiti Teknologi Malaysia.
- [35] Norazila Othman. 2009. *Development Of Ammonium Perchlorate+Aluminium Base Solid Propellant*. Bachelor degree Thesis. Universiti Teknologi Malaysia.
- [36] Noor Muhammad Feizal Muhalim. 2009. *Design Of 450N Nitrogen Tetroxide And Monomethyl Hydrazine Liquid Propellant Rocket Engine For Upper Stage Application*. Bachelor degree Thesis. Universiti Teknologi Malaysia.
- [37] Rao, G.V.R. 1958. Exhaust Nozzle contour for optimum thrust. *Jet Propulsion*. 28(6): 377–382.
- [38] Muhammad Idris Sazali. 2010. *Design Of Hydrogen Peroxide/Kerosene Liquid Rocket Engine*. Bachelor degree Thesis. Universiti Teknologi Malaysia.
- [39] Kuberaraaj Nambharaja. 2010. *Preparation And Characterization Of Rocket Grade Hydrogen Peroxide Monopropellant*. Bachelor degree Thesis. Universiti Teknologi Malaysia.
- [40] Khairul Muazam bin Shaharuddin. 2010. *Development Of Propellant Binder Using Natural Rubber*. Bachelor degree Thesis. Universiti Teknologi Malaysia.
- [41] Muhammad Nurizad Rosli. 2010. *Development Of Rocket Motor With Ceramic Insulator In Combustion Chamber*. Bachelor degree Thesis. Universiti Teknologi Malaysia.
- [42] Ahmad Fitri Abdullah. 2011. *Development of Ceramic Nozzle for 100N Rocket Motor*. Bachelor degree Thesis. Universiti Teknologi Malaysia.
- [43] Amir Aziz. 2011. *Combustion Characterization Of Ammonium Perchlorate Based Solid Rocket Propellant*. Master degree Thesis. Universiti Teknologi Malaysia.
- [44] Norazila Othman. 2011. *Design and development of 50-N Hydrogen Peroxide Monopropellant Rocket Thruster*. Master degree Thesis. Universiti Teknologi Malaysia.