

**ALMA MATER STUDIORUM - UNIVERSITÀ DI
BOLOGNA**

School of Engineering and Architecture
Department of Electrical, Electronic, and Information Engineering
"Guglielmo Marconi"

Master of Science in Electronic Engineering

Master Thesis

IN

ELECTRONIC AND COMMUNICATION SCIENCE AND TECHNOLOGY

**OFDM-based Schemes for Next
Generation Wireless Systems**

PRESENTED BY:

Oltjon Kodheli

SUPERVISOR:

**Prof. Alessandro Vanelli
Coralli**

CO-SUPERVISOR:

**Ing. Alessandro
Guidotti**

II SESSIONE

ANNO ACCADEMICO 2015/2016

Declaration of Authorship

I, OLTJON KODHELI, declare that this thesis titled, ‘OFDM-based schemes for next generation wireless systems’ and the work presented in it are my own. I confirm that:

- This work was done wholly while in candidature for a Master degree at this University.
- Where I have consulted the published work of others, this is always clearly attributed.
- Where I have quoted from the work of others, the source is always given. With the exception of such quotations, this thesis is entirely my own work.
- I have acknowledged all main sources of help.
- Where the thesis is based on work done by myself jointly with others, I have made clear exactly what was done by others and what I have contributed.

Date: **30.09.2016**

Signed:



Abstract

School of Engineering and Architecture

Department of Electrical, Electronic, and Information Engineering "Guglielmo
Marconi"

OFDM-based Schemes for Next Generation Wireless Systems

by Oltjon Kodheli

The purpose of this study is to investigate two candidate waveforms for next generation wireless systems, filtered Orthogonal Frequency Division Multiplexing (f-OFDM) and Unified Filtered Multi-Carrier (UFMC). The evaluation is done based on the power spectral density analysis of the signal and performance measurements in synchronous and asynchronous transmission. In f-OFDM we implement a soft truncated filter with length $1/3$ of OFDM symbol. In UFMC we use the Dolph-Chebyshev filter, limited to the length of zero padding (ZP). The simulation results demonstrates that both waveforms have a better spectral behaviour compared with conventional OFDM. However, the induced inter-symbol interference (ISI) caused by the filter in f-OFDM, and the inter-carrier interference (ICI) induced in UFMC due to cyclic prefix (CP) reduction, should be kept under control. In addition, in a synchronous transmission case with ideal parameters, f-OFDM and UFMC appear to have similar performance with OFDM. When carrier frequency offset (CFO) is imposed in the transmission, UFMC outperforms OFDM and f-OFDM.

Keywords - *OFDM, f-OFDM, UFMC, waveform, modulation, sub-carrier, spectrum, CFO, performance*

Acknowledgements

First of all I would like to express my sincere gratitude to my supervisor Prof. Alessandro Vanelli Coralli for his excellent guidance. Also I would like to thank the co-supervisor Ing. Alessandro Guidotti for his continual support during the thesis work. Their suggestions and comments helped me to improve my work.

I would like to state my gratitude and love to my family who has been a constant support not only during this thesis work, but throughout the two years of this master degree. Thank you for everything.

Contents

| | |
|---|-------------|
| Declaration of Authorship | iii |
| Abstract | iv |
| Acknowledgements | v |
| List of Figures | ix |
| List of Tables | xi |
| Abbreviations | xiii |
| | |
| 1 Introduction | 1 |
| 1.1 Research Motivation | 1 |
| 1.1.1 Why OFDM in First Place? | 1 |
| 1.1.2 Future Wireless Systems and Waveform Requirements | 2 |
| 1.1.3 OFDM Limitations | 4 |
| 1.2 Thesis Contribution | 5 |
| 1.3 Thesis Organization | 6 |
| | |
| 2 Orthogonal Frequency Division Multiplexing | 9 |
| 2.1 Mathematical Description of OFDM System | 10 |
| 2.1.1 OFDM Symbol | 10 |
| 2.1.2 Multipath Channel Characterization | 12 |
| 2.1.3 Cyclic Prefix | 13 |
| 2.1.4 Demodulation | 14 |
| 2.2 Discrete-Time Representation | 17 |
| 2.3 OFDM Spectrum and Spectral Efficiency | 19 |
| 2.4 Numerical Results | 20 |
| 2.5 Summary | 21 |
| | |
| 3 Filtered-OFDM | 23 |

| | | |
|----------|--|-----------|
| 3.1 | General Framework | 24 |
| 3.2 | F-OFDM Transceiver | 25 |
| 3.3 | Filter Design | 27 |
| 3.3.1 | Soft-Truncated Filter | 27 |
| 3.3.2 | Filter Parameters | 29 |
| 3.3.3 | Filter Tails | 30 |
| 3.4 | Numerical Results | 31 |
| 3.5 | Summary | 33 |
| 4 | UFMC: Universal Filtered Multi-Carrier | 35 |
| 4.1 | General Framework | 35 |
| 4.2 | UFMC Transceiver Structure | 37 |
| 4.3 | Doph-Chebyshev Window | 39 |
| 4.4 | Numerical Results | 40 |
| 4.5 | Summary | 41 |
| 5 | Performance Assessment | 43 |
| 5.1 | Spectrum Comparison of OFDM, f-OFDM, UFMC | 43 |
| 5.2 | Performance Analysis in Synchronous Transmission | 45 |
| 5.3 | Performance Analysis in Presence of Carrier Frequency Offset | 46 |
| 6 | Conclusions | 49 |
| 6.1 | Thesis Summary | 49 |
| 6.2 | Conclusions | 50 |
| 6.3 | Future Work | 51 |
| | Bibliography | 53 |

List of Figures

| | | |
|-----|---|----|
| 1.1 | Future Applications of 5G [3] | 2 |
| 2.1 | Multi-carrier Modulation | 9 |
| 2.2 | OFDM vs FDM | 10 |
| 2.3 | Multipath Propagation Scenario | 12 |
| 2.4 | 2-path Channel Example | 14 |
| 2.5 | CP Insertion | 14 |
| 2.6 | OFDM Baseband Block Diagram | 18 |
| 2.7 | OFDM spectrum | 19 |
| 2.8 | OFDM Spectrum | 21 |
| 3.1 | Co-existence of Waveforms [12] | 24 |
| 3.2 | f-OFDM Block Diagram [12] | 26 |
| 3.3 | Time and Frequency Representations of Windows | 28 |
| 3.4 | Blackman windowed sinc filter (M=31) | 30 |
| 3.5 | Blackman windowed sinc filter (M=47) | 30 |
| 3.6 | f-OFDM Symbol [17] | 31 |
| 3.7 | Extended CP | 31 |
| 3.8 | f-OFDM spectrum | 32 |
| 4.1 | Subband Filtering | 36 |
| 4.2 | UFMC Symbol [17] | 36 |
| 4.3 | UFMC Block Diagram | 38 |
| 4.4 | UFMC inBand Spectrum | 41 |
| 4.5 | UFMC Spectrum | 41 |
| 5.1 | Spectrum Comparison | 44 |
| 5.2 | Performance Comparison | 45 |
| 5.3 | OFDM performance in presence of CFO | 46 |
| 5.4 | f-OFDM performance in presence of CFO | 47 |
| 5.5 | UFMC performance in presence of CFO | 47 |
| 5.6 | Performance Comparison BER vs E_b/N_0 | 48 |

List of Tables

| | | |
|-----|---|----|
| 1.1 | Potential Requirements of Various 5G Applications [4] | 3 |
| 2.1 | Simulation Parameters OFDM | 20 |
| 3.1 | Simulation Parameters f-OFDM transceiver | 32 |
| 4.1 | Simulation Parameters UFMC transceiver | 40 |
| 5.1 | Simulation Parameters | 45 |

Abbreviations

| | |
|---------------|--|
| AWGN | Additive White Gaussian Noise |
| BER | Bit Error Rate |
| BS | Base Station |
| BW | Band Width |
| CFO | Carrier Frequency Offset |
| CP | Cyclic Prefix |
| DFT | Discrete Fourier Transform |
| EMBB | Enhanced Mobile Broad Band |
| FFT | Fast Fourier Transform |
| f-OFDM | filtered Orthogonal Frequency Division Multiplexing |
| ICI | Inter Carrier Interference |
| IDFT | Inverse Discrete Fourier Transform |
| IFFT | Inverse Fast Fourier Transform |
| IOT | Internet Of Things |
| ISI | Inter Symbol Interference |
| LTE | Long Term Evolution |
| M2M | Machine To Machine |
| MIMO | Multiple Input Multiple Output |
| MBB | Mobile Broad Band |
| MTC | Machine Type Communication |
| OFDM | Orthogonal Frequency Division Multiplexing |
| OOBE | Out Of Band Emissions |
| PAPR | Peak Average Power Ratio |
| QAM | Quadrature Amplitude Modulation |

| | |
|-------------|--|
| QPSK | Q uadrature P hase S hift K eying |
| SNR | S ignal N oise R atio |
| TTI | T ransmission T ime I nterval |
| UE | U ser E quipment |
| UFMC | U nified F iltered M ulti C arrier |
| URLL | U ltra R eliable L ow L atency |
| ZP | Z ero P refix |

To my family and friends

Chapter 1

Introduction

1.1 Research Motivation

1.1.1 Why OFDM in First Place?

Orthogonal Frequency Division Multiplexing(OFDM) is a multi-carrier modulation technique, that has been successfully applied to digital communication, over the last years. Together with the multiple access technology OFDMA, they define the physical layer standard of the fourth generation of mobile communication (4G). This modulation scheme has proven to be very efficient for a wide variety of digital communication services (3GPP LTE, IEEE 802.11a, DAB, DVB-T, DVB-H, ADSL), especially for Mobile Broadband (MBB). There are many reasons why OFDM is in the first place today and is widely used in many standards. Basically, it is very efficient in terms of:

- Spectral Efficiency: OFDM is very spectral efficient due to the fact that the spectrum is divided into sub-carriers which overlap with each other, but still maintain the orthogonality among them.
- Robustness against multipath propagation: Being a multi-carrier technique, it converts the series data symbols with high rate into parallel symbols with

lower rate, causing the symbol duration to be larger. Hence, a larger symbol duration makes the effect of delay spread of the channel negligible.

- Simple equalization: At the receiver a one-tap equalizer is needed. The effect of the channel is spread through all the sub-carriers. Therefore each sub-carrier feels the channel like being flat and a simple equalizer is needed to cancel the effect of the channel

Thanks to these benefits, OFDM is being considered for future 5G communication systems. However, as we will show in the next sections, an evolution of this waveform is needed so as to meet the challenging 5G requirements.

1.1.2 Future Wireless Systems and Waveform Requirements

The next generation of mobile communication (5G) is going to offer more than just the traditional MBB service. The main application it will provide are divided into three major categories: enhanced mobile broadband (eMBB), massive machine type communication (mMTC) and ultra reliable and low latency communication (uRLL) [1][2]. This is illustrated in figure 1.1.

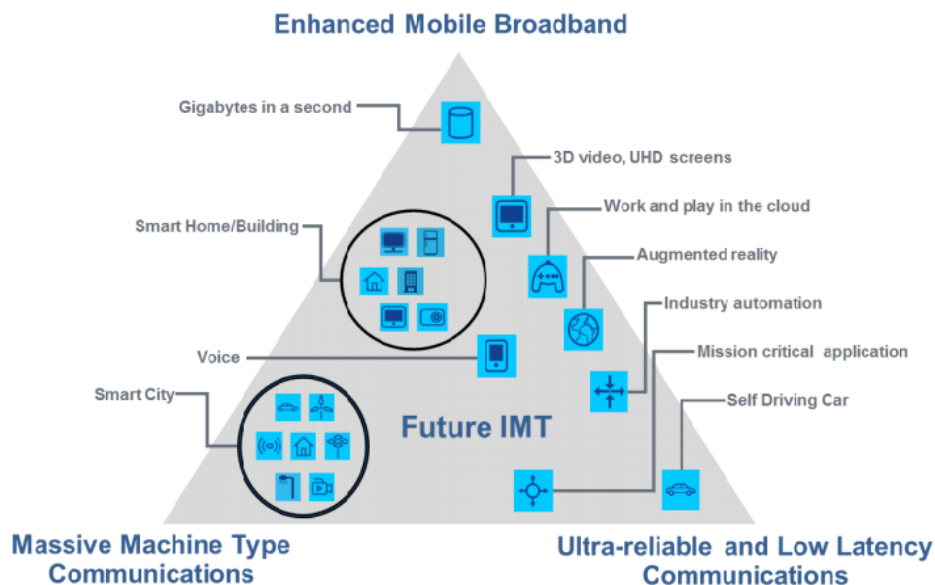

FIGURE 1.1: Future Applications of 5G [3]

Table 1.1 provides a complete picture of the future applications that 5G is expected to support.

| Scenario | Application | Requirements |
|----------|-----------------------|---|
| eMBB | UHD video, 3D video | ultra high data rate, low latency |
| | Virtual Reality | ultra high data rate, ultra low latency |
| | Augmented Reality | ultra high data rate, low latency |
| | Tactile Internet | ultra low latency |
| | Cloud Gaming | ultra high data rate, low latency |
| | Vehicular | ultra high data rate, support Doppler |
| uRLL | Industrial Automation | high reliability, high data rate, ultra low latency |
| | Self-driving Vehicles | high reliability, high data rate, ultra low latency |
| mMTC | Smart Home | operation in cluttered environment |
| | Smart Office | high reliability, obstacle penetration |
| | Smart City | high reliability, obstacle penetration |

TABLE 1.1: Potential Requirements of Various 5G Applications [4]

We can distinguish easily that every single applications imposes different requirements. Therefore, when investigating the Physical Layer (PHY) design for next generation of wireless systems, this requirements are the constraints to be considered.

Ideally, the waveform should have the following properties:

- low complexity - for machine type communication (MTC), low cost transceivers are needed, hence the computational complexity at the transmitter and receiver should be low.
- good spectral containment - the spectrum available for a particular service should be used in an efficient way, in order to relax the need for large guard bands between systems with neighbor frequencies.
- robustness against carrier frequency offset (CFO) - low cost transceiver are needed for MTC, hence poor oscillators can amplify CFO at the receiver.
- support multiple input multiple output (MIMO) - spatial multiplexing is a multiple antenna technique that increases the data rate as compared to single antenna techniques, hence MIMO becomes a key technology for future wireless systems.

- support asynchronous transmission - the need for strict synchronization would imply high cost transceiver and larger delays, which is something unwanted when trying to arrive at a throughput of 1 Gpps
- good localization in time - the demand for low latency imposes the need for having a well localized waveform in time-domain.
- flexible numerology - different kind of services implies different type of traffic. A flexible waveform [5][6] is needed in order to satisfy different traffic types.

The question that arises naturally is: **Is still OFDM in the first place?**

1.1.3 OFDM Limitations

To answer the question whether the OFDM can support the future wireless communication, let us have a look on the OFDM limitations [7]. The most important ones are listed below.

1. *Sensitivity to frequency and time offset*

The causes of carrier frequency offset can be different. It can occur due to impairments of the transmitter and receiver oscillators. Doppler effect can be a factor as well. The lost of orthogonality induced by CFO, causes a large ICI between sub-carriers. Therefore the reduction of the performance is considerable. Furthermore, if we consider OFDMA in an up-link case, time synchronization algorithms of different users are needed at the receiver. If the time of arrival of the signals from different users is not synchronized, the effect in terms of performance is large.

2. *Cyclic Prefix overhead*

In order to deal with ISI and ICI a CP is needed to be added in each OFDM symbol. We will see this in Chapter 2 when we are going to discuss in more detail the OFDM modulation. Nevertheless, based on LTE specifications,

the CP is around 7% of the OFDM symbol and causes an overhead in the transmission.

3. *Large peak to average power ratio (PAPR)*

Another important drawback of OFDM is large PAPR. Larger PAPR means that we can not push the amplifier of the transmitter to saturation, hence the energy available is not going to be used in an efficient way.

4. *Large out of band emissions (OOBE)*

Due to the rectangular pulse shape of each OFDM symbol in time domain, the frequency domain representation is a sinc function. Therefore the OOBE fall very slowly causing a bad spectral behaviour and imposing the need for large guard bands in order to satisfy spectrum masking.

It is clear enough that the OFDM modulation is not the perfect technique for future communication wireless systems. In terms of the new waveform requirements, it appears insufficient. However, the advantages it offers are precious and it is a good starting point when trying to look for new methods. The goal is to prevent all the advantages of OFDM and try to improve the limitations it imposes [8][9].

1.2 Thesis Contribution

In the scientific literature related to this topic, there are several proposals for future waveforms in order to satisfy the needs of next generation wireless systems. We are going to analyze in this thesis two of these proposed techniques, filtered-OFDM (f-OFDM) and Unified Filter Multi-Carrier (UFMC). The evaluation of f-OFDM and UFMC in this thesis will be done in two phases:

Firstly, numerical simulations are going to be performed through Matlab concentrating on the power spectral density of f-OFDM and UFMC.

Secondly, a performance assessment will be carried out in terms of BER vs E_b/N_0 in an AWGN channel. The results will be obtained through Matlab simulations of

a point-to-point communication scenario. The change of the performance having different CFO is going to be studied as well.

1.3 Thesis Organization

The thesis work is organized in six chapters. A brief description of each chapter is provided below:

- **Chapter 1: Introduction**

In this chapter an overview of the OFDM modulation is made, focusing more on its advantages and application in today standards of wireless communication. Furthermore, the waveform requirements for next generation wireless systems are listed and the limitations that OFDM offers to satisfy this requirements are emphasized. New modulation schemes techniques that are going to be analyzed in this thesis are introduced as well.

- **Chapter 2: Orthogonal Frequency Division Multiplexing**

Future generation wireless systems are expected to have OFDM-based modulation techniques. Therefore it is important to provide a detailed depiction of OFDM, starting from modulation, demodulation, channel model, transceiver structure and spectral efficiency. The last section of this chapter is dedicated to the numerical results of a point-to-point communication scenario, obtained through Matlab simulations, focused on the power spectral density of OFDM signal.

- **Chapter 3: Filtered-OFDM**

In this chapter a new modulation scheme technique f-OFDM is investigated. The mathematical description of f-OFDM symbol is given, as well as the transceiver structure. The filter technique and filter parameters used are presented as well. To conclude the chapter, the spectrum of f-OFDM signal obtained through Matlab simulations will be shown and interpreted.

- **Chapter 4: Unified Filtered Multi-Carrier**

The second proposal of alternative OFDM waveforms is presented and analyzed. We start with the UPMC symbol mathematical representation and the transceiver block diagram of UPMC. The filtered technique used in this scheme is discussed and finally we end with numerical simulation results like in the previous chapters.

- **Chapter 5: Performance Assessment**

Firstly, a comparison between OFDM, f-OFDM and UPMC signal spectrum is clearly shown and discussed. Furthermore, a performance analysis of all three modulation schemes is carried out, based on Matlab simulations of a point-to-point communication scenario in a AWGN channel. The robustness against CFO is demonstrated and analyzed as well.

- **Chapter 6: Conclusions**

The last chapter is dedicated in the conclusions, giving a brief summary of the thesis, conclusions and future work.

Chapter 2

Orthogonal Frequency Division Multiplexing

OFDM is a multi-carrier modulation scheme. In contrast with single-carrier modulation, it converts the series data streams into parallel data streams and perform modulation of data in different sub-carriers (see figure 2.1). The sub-carriers should be spaced in such a way that no inter-carrier interference is induced. One way is to keep them separated, imposing guard bands among them. By doing so we waste a lot of spectrum, hence it is needed to space the sub-carriers in such a way that they overlap, but still maintain the orthogonality. This is illustrated in figure 2.2.

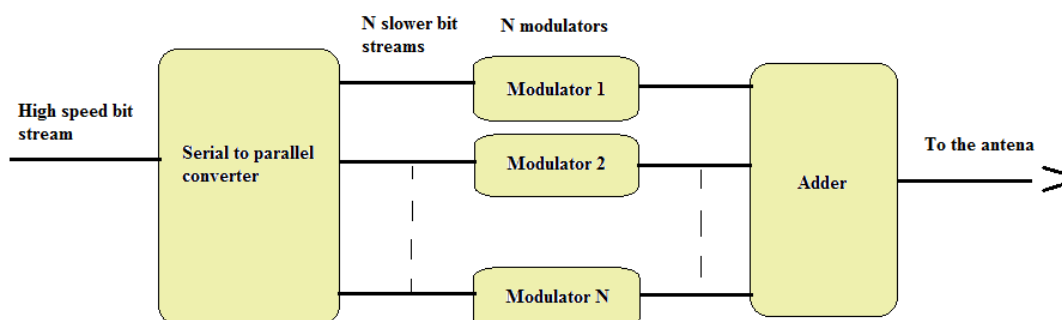

FIGURE 2.1: Multi-carrier Modulation

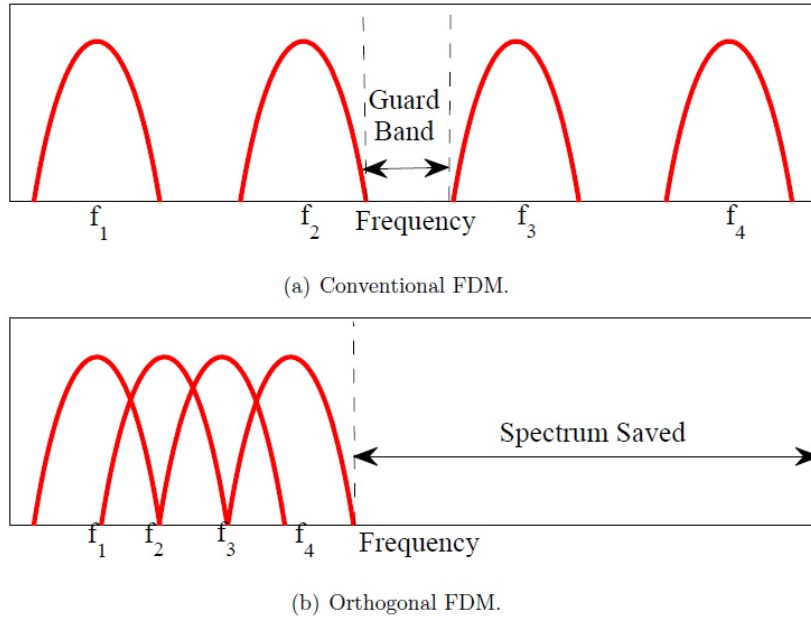

FIGURE 2.2: OFDM vs FDM

The mathematical representation of OFDM transceiver will be discussed in this chapter. We will start from the continuous time domain, passing to the discrete time representation of an OFDM system.

2.1 Mathematical Description of OFDM System

2.1.1 OFDM Symbol

Let us start by considering the construction of a single sub-carrier. Let the following orthogonal functions, be the basis functions of a bi-dimensional constellation, eg. 4-QAM, 16-QAM, etc.

$$\phi_{1u}(t) = \frac{1}{\sqrt{T}} \text{rect} \left(\frac{t - \frac{T}{2}}{T} \right) \cos(2\pi f_u t) \quad (2.1)$$

$$\phi_{2u}(t) = \frac{1}{\sqrt{T}} \text{rect} \left(\frac{t - \frac{T}{2}}{T} \right) \sin(2\pi f_u t) \quad (2.2)$$

where T is the symbol time and $f_u = \frac{u}{T}$ is the frequency of the u -th sub-carrier.

We can write eq. 2.1 and eq. 2.2 in a complex notation.

$$\phi_u(t) = \frac{1}{\sqrt{T}} \text{rect} \left(\frac{t - \frac{T}{2}}{T} \right) \exp(2\pi f_u t) \quad (2.3)$$

If we consider another basis function of another sub-carrier, we can write.

$$\phi_v(t) = \frac{1}{\sqrt{T}} \text{rect} \left(\frac{t - \frac{T}{2}}{T} \right) \exp(2\pi f_v t) \quad (2.4)$$

It holds that:

$$\int_{-\infty}^{+\infty} \phi_u \phi_v^* dt = \frac{1}{T} \int_0^T \exp \left[2\pi(u - v) \frac{t}{T} \right] dt = \begin{cases} 1, & \text{if } u=v \\ 0, & \text{otherwise} \end{cases} \quad (2.5)$$

Therefore to have orthogonality between sub-carriers, it is possible to use all the index numbers $u \neq v$. It is worth noticing that the minimum distance for ensuring orthogonality is $u - v = 1$. Hence, $\Delta f = \frac{1}{T}$. Let us now define N orthogonal functions as:

$$\phi_k(t) = \frac{1}{\sqrt{T}} \text{rect} \left(\frac{t - \frac{T}{2}}{T} \right) \exp(2\pi \Delta f k t) \quad k = 0, 1, \dots, N - 1 \quad (2.6)$$

where N is the number of sub-carriers. Each sub-carrier can carry 1 complex symbol, hence N sub-carriers will carry N symbols.

Organizing the series of complex symbols ($a_n \in \mathbb{C}$) with symbol rate $R_s = \frac{1}{T_s}$, in blocks of N parallel symbols $\vec{c}_l = [c_{0,l}, c_{1,l}, \dots, c_{k,l}, \dots, c_{N-1,l}]$, we can finally characterize the OFDM symbol:

$$x_l(t) = \sum_{k=0}^{N-1} c_{k,l} \phi_k(t - lT) \quad (2.7)$$

where $x_l(t)$ is the OFDM symbol generated at l -th symbol period T and $c_{k,l}$ is the k -th complex symbol carried from the k -th sub-carrier of the l -th OFDM block. By assuming a continuous transmission, the final signal can be written as follows:

$$x(t) = \sum_{l=-\infty}^{+\infty} \sum_{k=0}^{N-1} c_{k,l} \phi_k(t - lT) \quad (2.8)$$

It is worth noticing that the OFDM symbol duration is $T = NT_s$, therefore the OFDM symbol rate:

$$R_{ofdm} = \frac{1}{NT_s} = \frac{R_s}{N} \quad (2.9)$$

is N times slower than the symbol rate of symbols, coming from the digital constellation.

2.1.2 Multipath Channel Characterization

In wireless communication systems, the presence of multiple scatters (obstacles, vehicles, buildings etc.) causes the transmitted signal to arrive in different paths at the receiver. These multiple paths have different lengths. Therefore, the signal arriving at the receiver would be a superposition of all signals coming with different delays (see fig 2.3). This channel is said to be time-dispersive. Hence, the impulse response of the channel, would be a function of time $h(t, \tau)$.

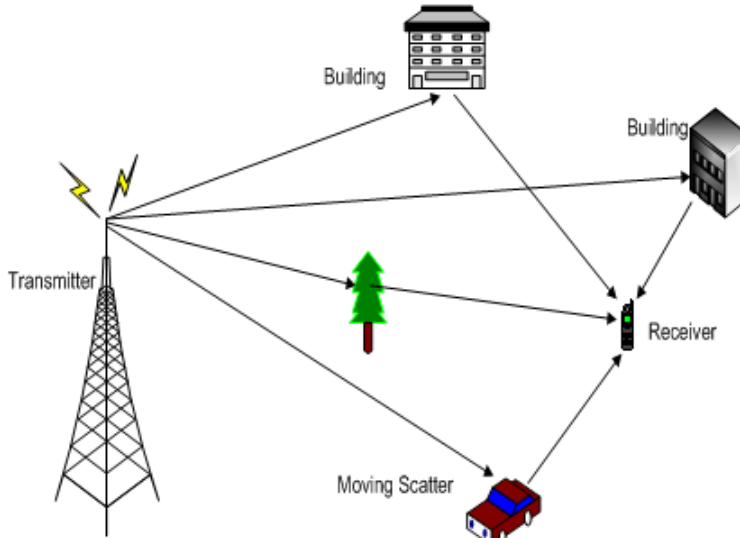

FIGURE 2.3: Multipath Propagation Scenario

In order to characterize our channel, let's consider a AWGN time dispersive channel. For simplicity, let's assume that our channel is time-invariant. It means

that:

$$h(\tau; t) = \begin{cases} h(\tau) & \text{if } \tau \in [0, \tau_{max}] \\ 0 & \text{otherwise} \end{cases} \quad (2.10)$$

where τ_{max} is the maximum delay spread. Passing the transmitted signal $x(t)$ through our channel, the output can be written as:

$$r(t) = h(\tau; t) * x(t) + n(t) = \int_{-\infty}^{+\infty} h(\tau; t)x(t - \tau) d\tau + n(t) \quad (2.11)$$

where $n(t)$ is the AWGN noise. Substituting eq. 2.10 on eq. 2.11 we obtain:

$$r(t) = h(\tau; t) * x(t) + n(t) = \int_0^{\tau_{max}} h(\tau)x(t - \tau) d\tau + n(t) \quad (2.12)$$

2.1.3 Cyclic Prefix

As we explained in the previous section, the transmitted signal arrives at the receiver through different paths and different delays. Hence, inter-symbol interference (ISI) is going to be induced in our transmission. Figure 2.4 represents an illustration of ISI effect. In order to avoid ISI we have to introduce guard bands in front of each OFDM symbol. If the guard band is larger than the maximum delay spread of the channel, it will perfectly cope with ISI. However, filling the guard period with a null transmission would imply the occurrence of ICI.

In order to cope with ICI, a cyclic prefix (CP) is added in front of each OFDM symbol. A part of the signal, is taken from the last part, and its added at the beginning of each OFDM symbol. We will understand this better in section 2.1.4 where we are going to demodulate our symbols. Finally, the basis functions now can be written as:

$$\tilde{\theta}_k(t) = \frac{1}{\sqrt{T}} \text{rect}\left(\frac{t - \frac{T_e}{2}}{T_e}\right) e^{j2\pi\Delta f k(t - T_{cp})} \quad k = 0, 1, 2, \dots, N - 1 \quad (2.13)$$

where $T_e = T + T_{cp}$ is the extended period after CP insertion.

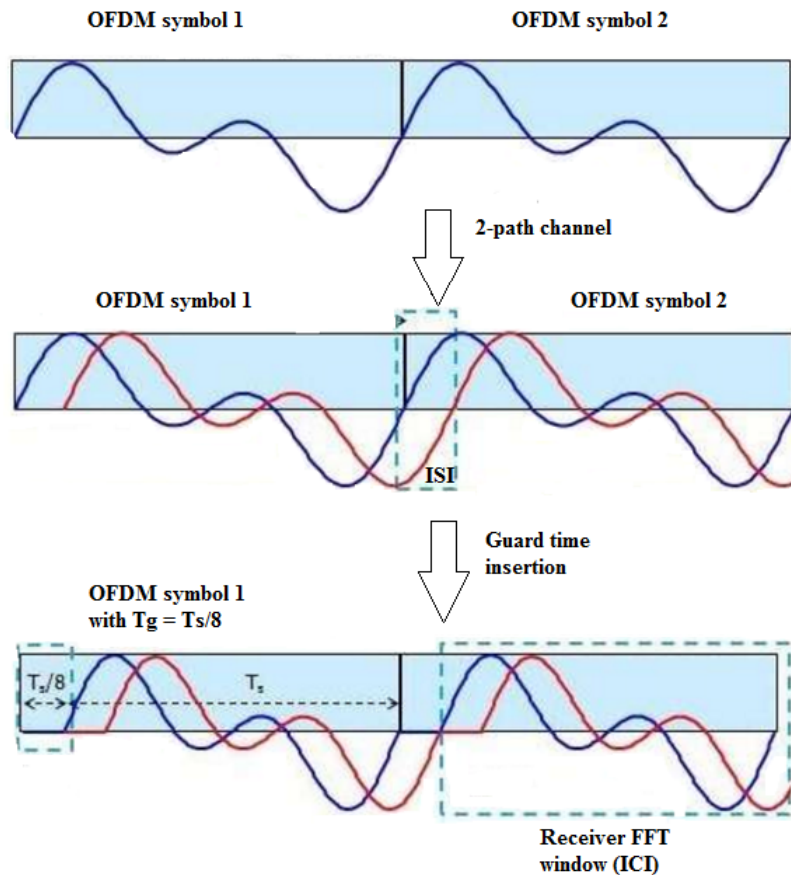

FIGURE 2.4: 2-path Channel Example

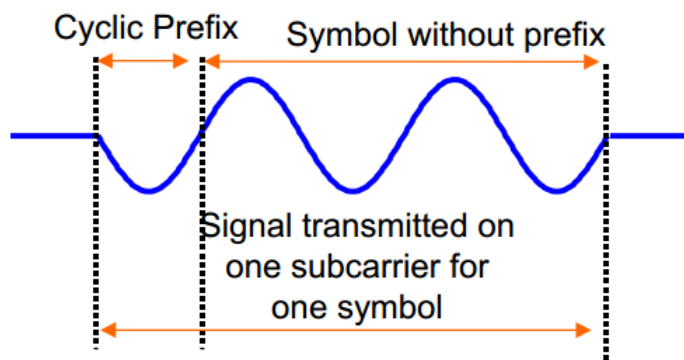

FIGURE 2.5: CP Insertion

2.1.4 Demodulation

At the receiver side, in order to recover the modulated symbols, we project the received signal onto the basis functions of each sub-carrier. This operation can be implemented through match filtering. Let's consider the case where we have to recover the l -th modulated symbol onto the l -th sub-carrier, transmitted over the

h-th time OFDM period. The received signal $r(t)$ is projected onto the conjugated version of l-th sub-carrier:

$$y_l(t) = \int_{hT}^{(h+1)T} r(t)\theta_l^*(t - hT) dt \quad (2.14)$$

For simplifying our calculations, let's assume $h = 0$. It hold that:

$$y_l(t) = \int_0^T r(t)\theta_l^*(t) dt \quad (2.15)$$

Taking into account the guard time T_{cp} where $T_e = T_{cp} + T$, we can still apply match filtering over the period $[T_{cp}, T_e]$. Therefore, eq. 2.15 can be written as:

$$y_l(t) = \int_{T_{cp}}^{T_e} r(t)\theta_l^*(t - T_{cp}) dt \quad (2.16)$$

Substituting the expression of the received signal $r(t)$ (eq. 2.12) onto the equation 2.16, it holds that:

$$\begin{aligned} y_{l,0} &= \int_{T_{cp}}^{T_e} \left[\int_0^{\tau_{max}} h(\tau)x(t - \tau) d\tau \right] \theta_l^*(t - T_{cp}) dt + \int_{T_{cp}}^{T_e} n(t)\theta_l^*(t - T_{cp}) dt \\ &= \int_{T_{cp}}^{T_e} \left[\int_0^{\tau_{max}} h(\tau) \sum_{k=0}^{N-1} c_{k,0}\theta_k(t - \tau) d\tau \right] \theta_l^*(t - T_{cp}) dt + n_l \\ &= \sum_{k=0}^{N-1} c_{k,0} \int_{T_{cp}}^{T_e} \left[\int_0^{\tau_{max}} h(\tau)\theta_k(t - \tau) d\tau \right] \theta_l^*(t - T_{cp}) dt + n_l \end{aligned} \quad (2.17)$$

where n_l is the noise projected onto the l -th sub-carrier. Then we substitute the expression of θ_k (see eq. 2.13) in the previous equation.

$$\begin{aligned}
y_{l,0} &= \sum_{k=0}^{N-1} c_{k,0} \int_{T_{cp}}^{T_e} \left[\int_0^{\tau_{max}} h(\tau) \frac{1}{\sqrt{T}} e^{2\pi\Delta f k(t-T_{cp}-\tau)} d\tau \right] \theta_l^*(t - T_{cp}) dt + n_l \\
&= \frac{1}{\sqrt{T}} \sum_{k=0}^{N-1} c_{k,0} \int_{T_{cp}}^{T_e} e^{j2\pi\Delta f(t-T_{cp})} \left[\int_0^{\tau_{max}} h(\tau) e^{-2\pi\Delta f k\tau} d\tau \right] \theta_l^*(t - T_{cp}) dt + n_l
\end{aligned} \tag{2.18}$$

We can interpret the inner integral:

$$\int_0^{\tau_{max}} h(\tau) e^{-j2\pi\Delta f k\tau} d\tau = \int_{-\infty}^{+\infty} h(\tau) e^{-j2\pi\Delta f k\tau} d\tau = H(f_k) \tag{2.19}$$

as the Fourier transform of the channel impulse response $F\{h(t)\}$. Hence it follows:

$$\begin{aligned}
y_{l,0} &= \frac{1}{\sqrt{T}} \sum_{k=0}^{N-1} H(f_k) c_{k,0} \int_{T_{cp}}^{T_e} e^{2\pi\Delta f k(t-T_{cp})} \theta_l^*(t - T_{cp}) dt + n_l \\
&= \frac{1}{\sqrt{T}} \sum_{k=0}^{N-1} H(f_k) c_{k,0} \int_{T_{cp}}^{T_e} e^{j2\pi\Delta f k(t-T_{cp})} e^{-j2\pi\Delta f l(t-T_{cp})} dt + n_l
\end{aligned} \tag{2.20}$$

Notice that:

$$\int_{T_{cp}}^{T_e} e^{j2\pi\Delta f k(t-T_{cp})} e^{-j2\pi\Delta f l(t-T_{cp})} dt = \begin{cases} 1, & \text{if } k=l \\ 0, & \text{otherwise} \end{cases} \tag{2.21}$$

Finally we are able to demodulate the symbol modulated onto the l -th subcarrier.

$$y_{l,0} = H(f_l) c_{l,0} + n_l \tag{2.22}$$

This is a results that is worthwhile analyzing. The equation 2.22 yields that the effect of the channel is not spread over the all modulated symbols, as in the case of single-carrier transmission, but it is concentrated on a single symbol. As a result, at the receiver side a single-tap equalizer for each sub-carrier is required, in order

to cancel the effect of the channel on our symbols.

We can now turn our attention to understanding the importance of the Cyclic Prefix (see eq. 2.21). We can understand by intuition that leaving the guard time empty, means wasting the mutual orthogonality between sub-carriers. The result of the integral is not going to be 0, because the functions are not going to be exponential in all the integration interval. This is illustrated in figure 2.5. In this particular case, the demodulated symbol is going to be as follows:

$$y_{l,0} = H(f_l)c_{l,0} + \sum_{k=0, k \neq l}^{N-1} c_{k,0} + n_l \quad (2.23)$$

where $\sum_{k=0, k \neq l}^{N-1} c_{k,0}$ is the ICI term.

2.2 Discrete-Time Representation

Based on the previous section, where we discussed the continuous time model of the OFDM symbol, transmitter and receiver, we can build the discrete-time model.

Let us start by constructing the discrete-time OFDM symbol. In order to write the sampled version of OFDM, we have to define the sampling period T_s .

We know that:

$$\frac{1}{T_s} = B = N\Delta f = N\frac{1}{T} \quad (2.24)$$

Hence the sampling period $T_s = \frac{T}{N}$ and the sampling frequency $f_s = \frac{N}{T}$. Therefore, $x(t)$ is equivalent to the following sampled version :

$$\begin{aligned} x_l(nT_s) &= \frac{1}{\sqrt{N}} \sum_{k=0}^{N-1} c_{k,l} e^{j2\pi\Delta f knT_s - lT} \\ &= \frac{1}{\sqrt{N}} \sum_{k=0}^{N-1} c_{k,l} e^{j2\pi\frac{1}{T} knT_s} \\ &= \frac{1}{\sqrt{N}} \sum_{k=0}^{N-1} c_{k,l} e^{j2\pi\frac{1}{N} kn} \end{aligned} \quad (2.25)$$

Given a discrete sequence $x(n)$, where $0 < n < N$, by definition its Discrete Fourier Transform (DFT) and Inverse Discrete Fourier Transform (IDFT) can be written as:

$$DFT\{x[n]\} = X[i] = \frac{1}{\sqrt{N}} \sum_{n=0}^{N-1} x[n] e^{-j2\pi in/N} \quad i = 0, 1, \dots, N-1 \quad (2.26)$$

$$IDFT\{X[i]\} = X[n] = \frac{1}{\sqrt{N}} \sum_{i=0}^{N-1} X[i] e^{j2\pi in/N} \quad n = 0, 1, \dots, N-1 \quad (2.27)$$

It is worth noticing that equation 2.25 represents the IDFT of the frequency sequence $\{c_k\}$. On the other hand to perform demodulation on the received signal it is enough to apply DFT of the received sequence $\{r[n]\}$. For complexity reasons, we tend to use a power of 2 IDFT and DFT because the processing time is lower. Using a power of 2 IDFT and DFT allows us to use Fast Fourier Transform (FFT) and Inverse Fast Fourier Transform (IFFT).

The block diagram of the transceiver discrete time OFDM is illustrated in figure 2.6.

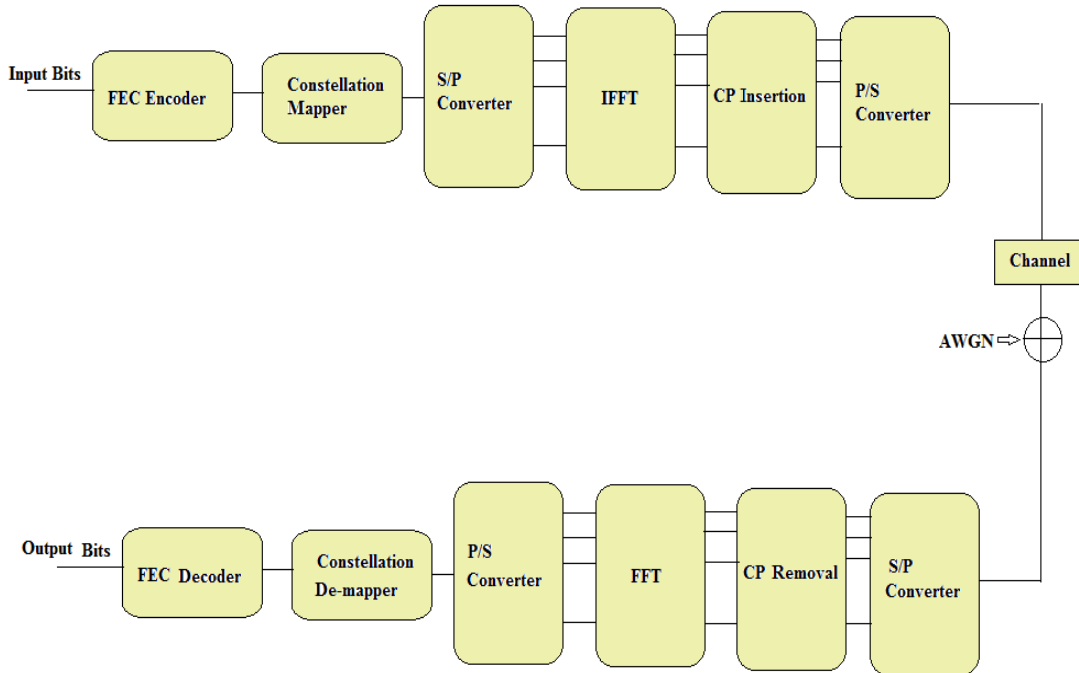

FIGURE 2.6: OFDM Baseband Block Diagram

2.3 OFDM Spectrum and Spectral Efficiency

It is well known that OFDM uses a rectangular pulse shape in time domain and that the frequency response of a rectangular window is a sinc() function. Therefore the spectrum of an OFDM signal is a linear combination of sinc() pulses equally spaced by a frequency $\Delta f = 1/T$. This is illustrated in figure 2.7.

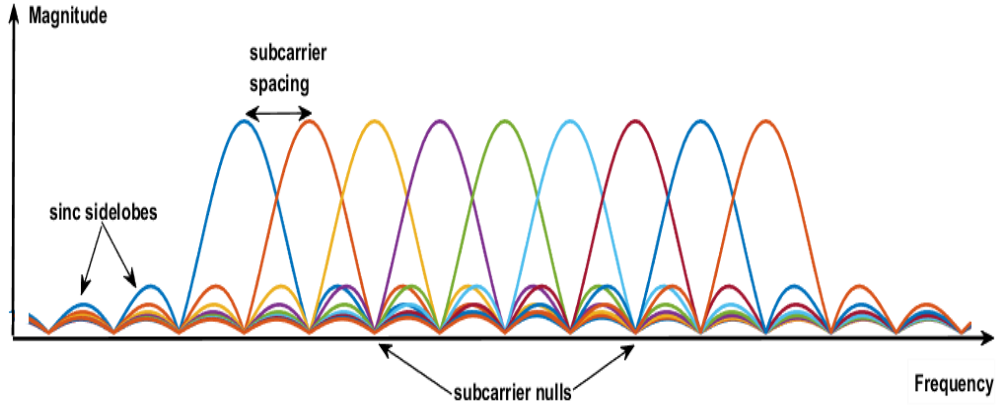

FIGURE 2.7: OFDM spectrum

The occupied bandwidth for OFDM transmission is $B = N\Delta f$. However, not all the sub-carriers are used for transmission. Near the spectrum edges (see 2.7), a certain number of sub-carriers are nulled to reduce the channel interference in adjacent channels. The remaining sub-carriers that are non-nulled are called *active sub-carriers* N_a . It is possible to define the **active carrier efficiency** as :

$$\eta_a = \frac{N_a}{N} \quad (2.28)$$

Not all the active sub-carriers are modulated with useful data. Some of the sub-carrier are filled with pilots for synchronization purposes. Let N_p be the number of sub-carriers filled with pilot data. The **information carrier efficiency** can be written as:

$$\eta_p = \frac{N_a - N_p}{N_a} \quad (2.29)$$

Based on the previous definitions, it is possible to define the **carrier utilization efficiency**:

$$\eta_u = \eta_a \eta_p = \frac{N_a - N_p}{N} \quad (2.30)$$

Another reason for the reduction of spectral efficiency is the insertion of the cyclic prefix. Inserting a cyclic prefix means extending the Symbol period T by a guard time T_{cp} . It is now possible to write the relation for the **guard time efficiency**:

$$\eta_g = \frac{T}{T_{cp} + T} \quad (2.31)$$

To define the overall spectral efficiency for the OFDM transmission, we need to take into account even the coding rate r_c and the cardinality of the digital constellation M . The **overall spectral efficiency** can be defined as:

$$\eta_g = r_c \log_2(M) \eta_a \eta_p \eta_g \quad (2.32)$$

2.4 Numerical Results

In this section a simple OFDM transceiver scheme is simulated through Matlab. The main goal is to analyze the spectrum containment. In order to perform simulations we have to characterize the parameters to be used. In this case we are going to take into consideration the Mobile WiMax standard parameters for the OFDM transceiver. However we can take into consideration any possible standard. All this parameters are summarized in the following table:

| Parameter | Value based on Mobile WiMAX standard |
|------------------------------------|--------------------------------------|
| FFT/IFFT size | 512 |
| Number of used data subcarriers | 360 |
| Number of pilot subcarriers | 12 |
| Number of guard bands | 92 (18 %) |
| Cyclic Prefix | 1/8 |
| Channel Bandwidth (MHz) | 5 |
| Subcarrier frequency spacing (kHz) | 10.94 |
| Useful symbol time (micro s) | 91.4 |
| Modulation | QPSK |
| Channel model | AWGN |
| Coding rate | uncoded |

TABLE 2.1: Simulation Parameters OFDM

After setting the parameters like in table 2.1, we plot the Power Spectral Density of the OFDM signal. This is illustrated in figure 2.8. As we expected, we see that the frequencies out of the BW fall very slowly. In spectrum edges of the $5MHz$ BW, we have $-25dB$ of attenuation. We have used in this case approximately 18% guard band in order to satisfy the spectrum mask needed. Therefore only 82% of the $5MHz$ which is $4.1MHz$ is used for the transmission of data. It means that the spectrum wasted is considerably large and the OOBs are very high.

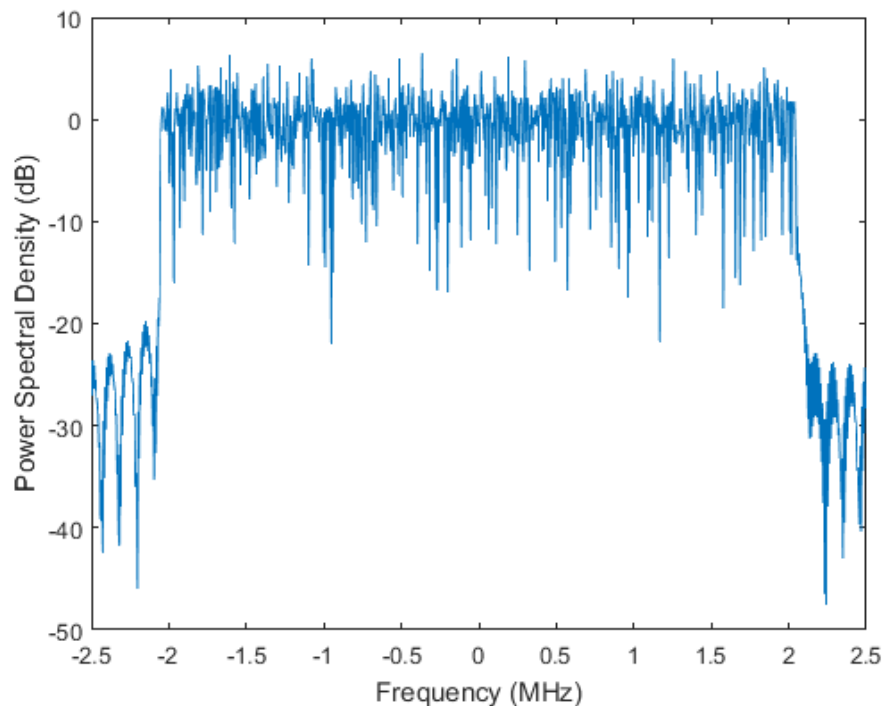

FIGURE 2.8: OFDM Spectrum

2.5 Summary

In this chapter an overall picture of OFDM modulation scheme was made. We started from characterizing the OFDM symbol, going on with the multipath channel model. The mathematical derivations of the recovering data at the receiver through performing demodulation was analyzed. Then going from continuous time domain to discrete time domain we defined the OFDM discrete time signal and

built the baseband block diagram of OFDM transceiver. In the last section of this chapter the simulation result of OFDM spectrum was shown and interpreted.

Chapter 3

Filtered-OFDM

We present in this chapter, an enabler for flexible waveform, named filtered OFDM (f-OFDM). We will see through this chapter that this waveform appears in many aspects better than the conventional OFDM[10]. Firstly, in contrast with conventional OFDM used in LTE/LTE-A nowadays, where a unified numerology is applied across all the assigned bandwidth (20 MHz), in f-OFDM the available bandwidth is divided in several sub-bands, each one having different numerology and accommodating different kind of services. This is a key feature to enable flexibility of the physical layer, which is a basic requirement for the next generation of mobile communication (5G). Secondly, even though OFDM is considered to be spectrum efficient, still 10% of allocated BW is wasted to allow attenuation of the signal. For sure we can do better than that and f-OFDM is a solution. The need of guard band is relaxed because the OOB is suppressed by the filter. Thirdly, to achieve orthogonality both in frequency and time in OFDM, extra signaling to assure synchronization is needed, especially for up-link transmission. Failures in perfect synchronization, will lead to performance degradation. In contrast, in f-OFDM the need for strict synchronization is relaxed.

Through this chapter, a general framework of f-OFDM will be given. Filtering technique used and filter parameters is going to be discussed. At the end, some simulation results will be shown, mainly focusing on the f-OFDM spectrum.

3.1 General Framework

It is expected that a larger bandwidth (100-200 MHz) will be assigned for 5G [11], in order to boost the data rate. According to the f-OFDM technique, this bandwidth is splitted in several sub-bands, each one filtered independently. In this way, we brake intentionally the time-domain orthogonality between consecutive f-OFDM symbols for lower OOB. Consequently, asynchronous transmission between sub-band is now supported. Each sub-band has different waveform parameters, meaning different length of CP, sub-carrier spacing and transmission time interval (TTI). Therefore, it is possible that in different sub-band to provide different kind of services, depending on the type of traffic.

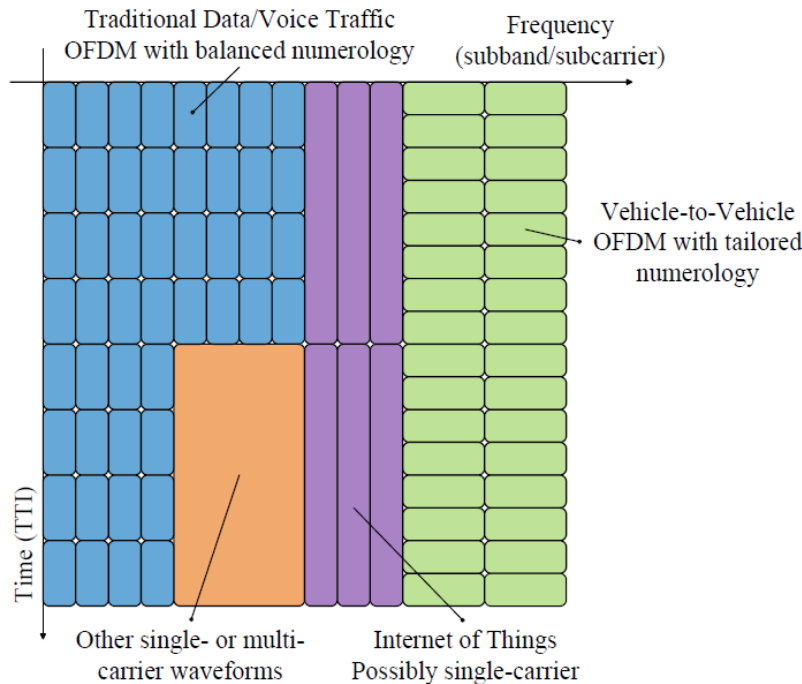

FIGURE 3.1: Co-existence of Waveforms [12]

To illustrate the coexistence of different f-OFDM waveforms, let us analyze figure 3.1. The time-frequency arrangement changes depending on the type of service. For example, in IOT scenario a single carrier modulation scheme may be used rather than OFDM. Meanwhile, in M2M communication, ultra low latency and high reliability are strictly needed. Therefore, providing a very short TTI allows to have a lower latency in the transmission of information as required. In other

kind of services other numerology can be needed and f-OFDM its capable of enabling it. Nevertheless, the performance is strictly limited in designing a proper filter depending on the situation. This is going to be discussed later through this chapter.

3.2 F-OFDM Transciever

Let us consider a down-link scenario of f-OFDM as shown in figure 3.2. We see that in Base Station (BS) side, depending on the service request, different numerology can be applied. For example, different subcarrier spacing, IFFT length and CP length. At the user equipment (UE) side, each UE will perform filtering with filter parameters arranged in this way, so as to match with that of the BS side and to take the service needed. This example also will work in an up-link case, where each UE will send the data to the BS, and will perform filtering operation in each sub-band allocated for different type of services. It worth noticing that in an up-link scenario of f-OFDM, synchronization need is relaxed because the waveforms are well localized in frequency.

Let us now mathematically characterize the f-OFDM symbol. This is very important in order to understand the operations needed at the transmitter and the receiver side. In order to do this, let us consider an up-link scenario where we have M UE transmitting at the BS. Starting from discrete time representation of OFDM symbol:

$$x_u(n) = \frac{1}{\sqrt{N}} \sum_{k=0}^{N-1} c_k e^{j2\pi kn/N} \quad (3.1)$$

and reminding that filtering operation is a convolution operation from the mathematical point of view, we can finally write:

$$\tilde{x}_u(n) = x_u(n) * f_u(n) \quad (3.2)$$

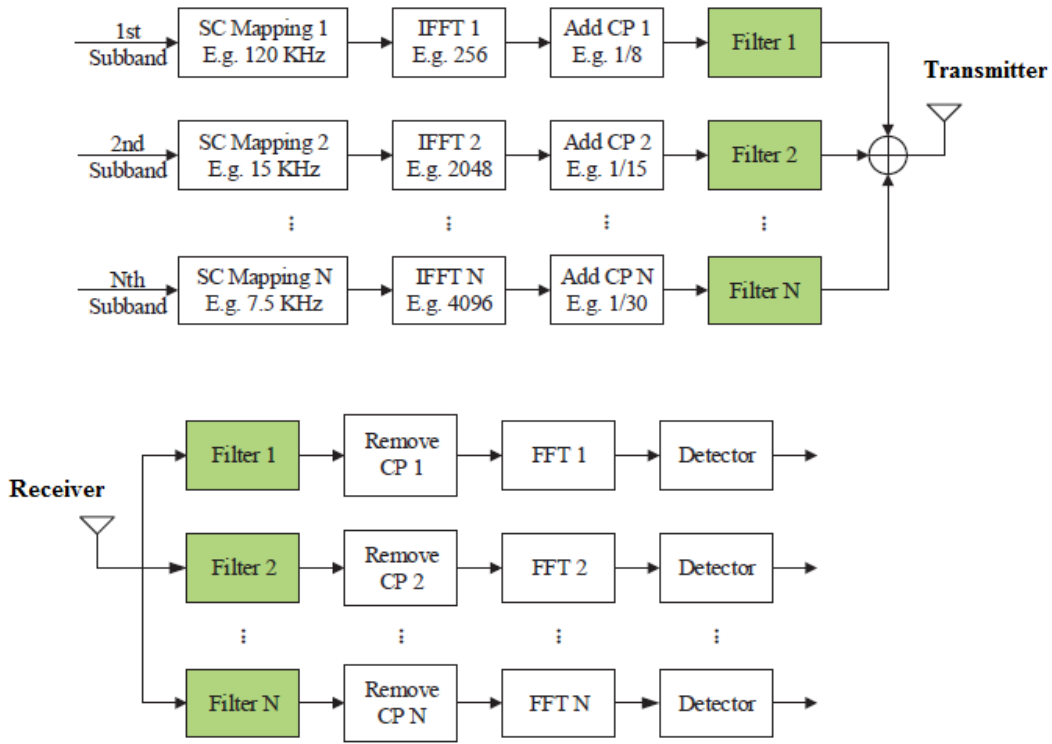

FIGURE 3.2: f-OFDM Block Diagram [12]

where $x_u(n)$ is the signal of the u -th UE and $f_u(n)$ is its particular filter. The spectrum shaping filter $f_u(n)$ should be appropriately designed in order to suppress only the out of band emissions. It means that it should have a central frequency in the middle of the assigned sub-carriers and the bandpass of the filter should include all the sub-carriers of the OFDM symbol.

The signal received at the BS side will have the following form:

$$r(n) = \sum_{u=1}^M \tilde{s}_u(n) * h_u(n) + w_u(n) \quad (3.3)$$

where M is the number of UEs, $\tilde{s}_u(n)$ is the signal coming from u -th UE, $h_u(n)$ is the channel impulse response of the u -th channel and $w_u(n)$ is the noise.

The BS receives the signal $r(t)$ and passes it through the filter $f_u^*(-n)$ which is matched with the transmitter filter of each UE f_u .

$$r_u(n) = r(n) * f_u^*(-n) \quad (3.4)$$

The role of the matched filter is to reject the interference from other UEs and it maximizes the signal-to-noise ratio (SNR). The BS should have a bank of filters, in order to get the symbols from each UE. Each filter at the receiver should be designed with the right parameters, centered frequency and BW in order to not have performance degradation. Then the demodulation procedure is like in the case of OFDM that we discussed in Chapter 2. The end-to-end channel $f_n(n) * h_u(n) * f_u^*(-n)$ should be estimated and equalized at the receiver. Therefore we will have an increasing of the complexity due to filtering at the transmitter and at the receiver, but still maintaining all the other advantages.

3.3 Filter Design

Whenever we have to design and implement a filter, we have to take into account the trade off between time and frequency localization of the filter [13][14]. A longer filter in the time domain, would provide a better spectrum containment, meaning better suppressing of the out of band emissions, and vice versa. Therefore, in order to take advantage of f-OFDM, a proper design technique needs to be implemented. Choosing the best filter is a difficult approach. However, based even in the scientific papers related to this topic [12][15], we are going to choose the soft-truncated filter.

3.3.1 Soft-Truncated Filter

As we know, an infinite sinc function in the time domain, gives us the ideal low-pass filter. All frequencies below the cutoff frequency are passed with unitary amplitude, whereas the other frequencies are blocked. This would be ideal if we can implement it, however we can not filter our signal for an infinite time. Therefore, it is important to truncate the sinc-function, leading us to the windowed-sinc filter or called differently soft truncated filter. We will implement the filter in the discrete time domain, so we will consider the discrete time representation of the filter.

In order to truncate the sinc function, the well known windowing functions [16] are considered:

- Rectangular:

$$h(n) = K_1 \text{rect}\left(\frac{n - M/2}{M}\right) \quad (3.5)$$

- Hamming:

$$h(n) = K_2 \left(0.54 - 0.46 \cos\left(\frac{2\pi n}{M}\right)\right) \quad (3.6)$$

- Hanning:

$$h(n) = K_3 \left(0.5 - 0.5 \cos\left(\frac{2\pi n}{M}\right)\right) \quad (3.7)$$

- Blackman:

$$h(n) = K_4 \left(0.42 - 0.5 \cos\left(\frac{2\pi n}{M}\right) + 0.08 \cos\left(\frac{4\pi n}{M}\right)\right) \quad (3.8)$$

where M is the number of taps of the discrete time filter, or usually called the filter length and K_1 to K_4 are the normalization factors. $n = 0, 1, \dots, M$

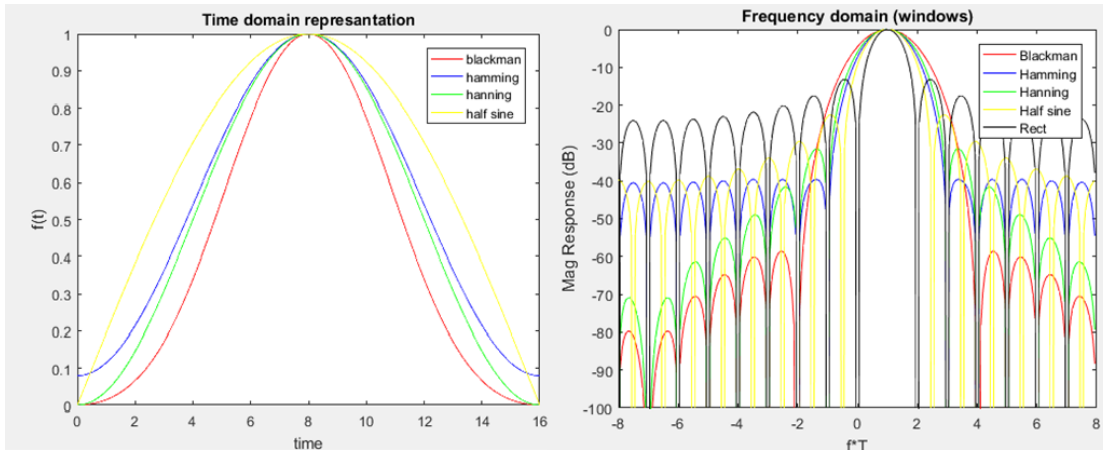

FIGURE 3.3: Time and Frequency Representations of Windows

Analyzing figure 3.3, it is obvious that the window which allows to have a better attenuation in the stop band is the Blackman window. It also has the advantage that gives less ripples in the passband with the cost of a higher transition band. For performing simulations we are going to choose the Blackman windowed-sinc

filter. However any kind of window, apart from rectangular one, would be a good choice.

Finally our filter can be expressed by the following mathematical description:

$$h(n) = K \frac{\sin(2\pi f_c(n - M/2))}{n - M/2} [0.42 - 0.5\cos(\frac{2\pi n}{M}) + 0.08\cos(\frac{4\pi n}{M})] \quad (3.9)$$

3.3.2 Filter Parameters

From equation 3.9 it is important to discuss the parameters of our filter, which are also our degrees of freedom in designing the proper filter.

f_c is the cutoff frequency. This is a parameter that we can choose depending on the transceiver structure. The important thing to mention here is that we need to assure that all the subcarriers that we want to filter should be inside the passband, otherwise we will lose information data. For example, choosing a cutoff frequency $f_c = 0.5$, it is enough to upsample the OFDM symbol by a factor of 2, before we apply filtering. Otherwise, applying filtering directly, would mean losing half of the information symbols.

M is the number of samples, called differently the length of the filter. This is a parameter that we can choose, taking into account the trade of between time and frequency localization. Applying filtering for a longer time, will lead to a greater overhead, which is something that we should keep under control.

On the other hand, a longer filter means a better attenuation in the stopband, allowing a better utilization of the available spectrum, because the need for guard bands is going to be relaxed. Analyzing figure 3.4 and 3.5 we can see that increasing filter length have an effect even in the pass band, decreasing the ripples. Less ripples means less distortion in the symbols we need to transmit, hence we have to take into consideration even this.

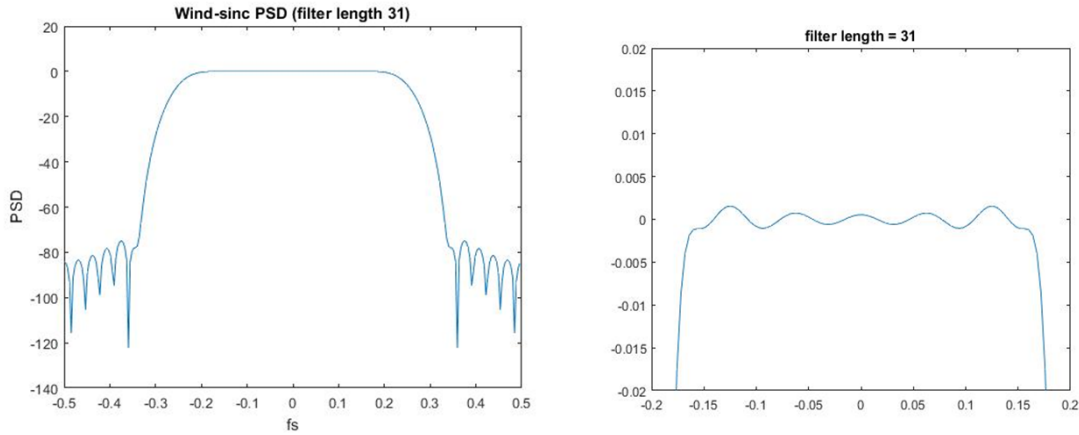
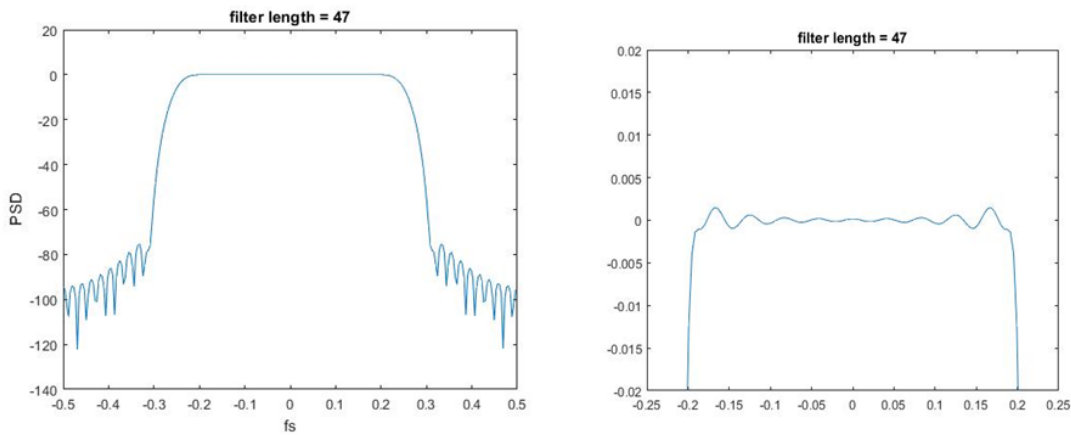
FIGURE 3.4: Blackman windowed sinc filter ($M=31$)FIGURE 3.5: Blackman windowed sinc filter ($M=47$)

3.3.3 Filter Tails

As we previously mentioned, filtering is a convolution operation, hence it introduces filter tails to the OFDM symbol (see fig 3.6).

We discussed in chapter 2 that in order to deal with ISI and ICI problem, we have to add a CP in front of each OFDM symbol.

In f-OFDM, due to filtering operation, the symbol duration is increased to $N+M-1$, where N is the OFDM symbol duration and M is the filter length. Hence, we will introduce ISI in consecutive symbols arriving at the receiver. In order to cope with this ISI we can enlarge the CP (see fig 3.7), so as to cancel both, the effect of multipath and filtering. However it is worth noticing that the main energy of filtering operation is concentrated on CP, and therefore its induced ISI

is very limited. Furthermore, enlarging the CP means reducing the performance by introducing a larger overhead, so we need to avoid it.

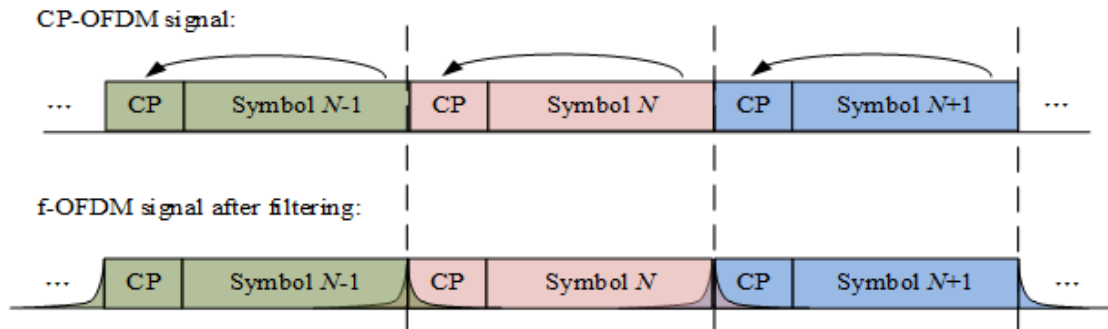

FIGURE 3.6: f-OFDM Symbol [17]

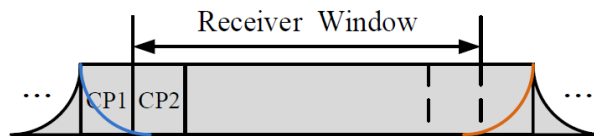

FIGURE 3.7: Extended CP

Finally, we can say that no treatment is needed for the filter tails. We have to accept it as an added noise to the next symbol, as long as its effect is very small in terms of reduction of performance.

3.4 Numerical Results

In this section we are going to discuss the results of the numerical simulation in Matlab of a point to point f-OFDM transceiver. The parameters used to built our transceiver structure are going to be listed in table 3.1. As we mentioned even in the previous chapter, this parameters are based on the Mobile WiMax standard, and we will follow this parameters for each scheme in order to be able to compare the results. Another important parameter to set is the order of the filter. Based even in the scientific literature about this topic, we are going to use a filter length $M = T/3$, which means 1/3 of the symbol time.

| Parameter | Value based on Mobile WiMAX standard |
|------------------------------------|--------------------------------------|
| FFT/IFFT size | 512 |
| Number of used data subcarriers | 360 |
| Number of pilot subcarriers | 12 |
| Number of guard bands | 32 (6 percent) |
| Cyclic Prefix | 1/8 |
| Channel Bandwidth (MHz) | 5 |
| Subcarrier frequency spacing (kHz) | 10.94 |
| Useful symbol time (micro s) | 91.4 |
| Modulation | QPSK |
| Channel model | AWGN |
| Coding rate | uncoded |
| Order of the filter M | 127 (1/3 of symbol time) |

TABLE 3.1: Simulation Parameters f-OFDM transceiver

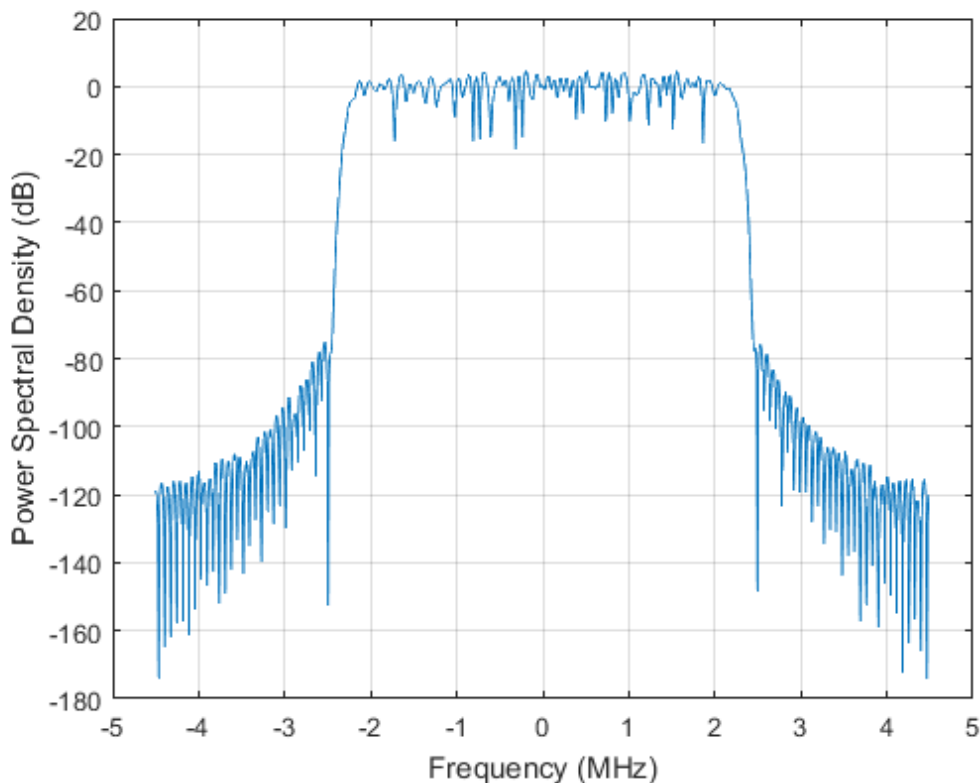

FIGURE 3.8: f-OFDM spectrum

We distinguish a great improvement of PSD compared with OFDM. It is also worth noticing that the guard band used here is approximately 6%, which is 1/3 of the guard band used in OFDM. It means that we have a considerable gain in the utilization of spectrum. However to make a full comparison with OFDM we have

to make a performance assessment, not only just the comparison of the spectrum (see Chapter 5).

3.5 Summary

In this chapter f-OFDM was studied. Some conceptual comparison with OFDM was made and what f-OFDM offers was discussed. Also the OFDM signal was characterized and filtering technique was analyzed. At the end the spectrum of f-OFDM was shown and interpreted.

Chapter 4

UFMC: Universal Filtered Multi-Carrier

Universal filtered multi-carrier (UFMC) is a potential candidate waveform for future wireless systems. It is also known as unified filtered OFDM (UF-OFDM). In this chapter we are going to start with a general picture of UFMC, going on with the mathematical description of UFMC transceiver. The filtering technique applied to this method will be discussed as well. We will finally conclude with some numerical results of UFMC spectrum.

4.1 General Framework

While f-OFDM filters the whole band for a specific service provided inside that band, UFMC divides the band assigned for a user in smaller sub-bands (see figure 4.1), and after filtering them separately, they are summed and sent through the channel. Both methods are similar, in the sense that they both imply filtering technique, but the way in which filtering is applied and the receiver structure is different. As we mentioned even in the previous chapter, filtering operation makes the symbol to be longer in time, causing consecutive symbols to overlap. Due to this filter tails, UFMC uses a null transmission or known as zero padding in

front of each symbol, in order to cope with both, the delay spread of the channel and filter tails. Using a null transmission as a guard band and not a CP means introducing ICI, as we previously discussed and explained in Chapter 1. In UFMC we intentionally introduce this ICI. Only by intuition we can understand that the ICI in this case is going to be lower because we filtering a specified number of subbands inside the whole band. The more subbands we filter inside a band, the less the effect of ICI would be. It is worth noticing that the filter length should be limited to the length of ZP in order to have an orthogonal waveform in the time-domain (see figure 4.2), as we are wasting the orthogonality in the frequency domain.

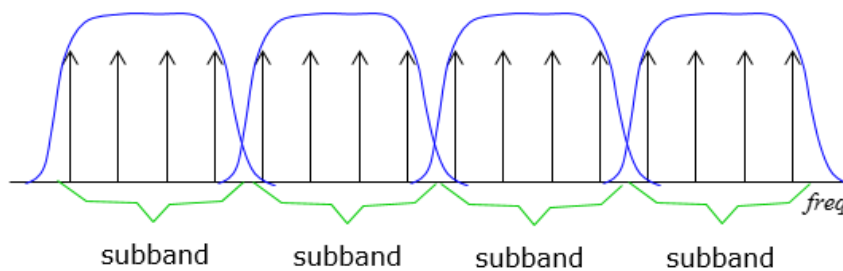

FIGURE 4.1: Subband Filtering

In contrast, in f-OFDM we use the CP to ensure an ICI free transmission, but we use long filters for a better spectrum localization, with the cost of introducing some ISI. While in UFMC we maintain orthogonality in time-domain, in f-OFDM we maintain it in frequency domain.

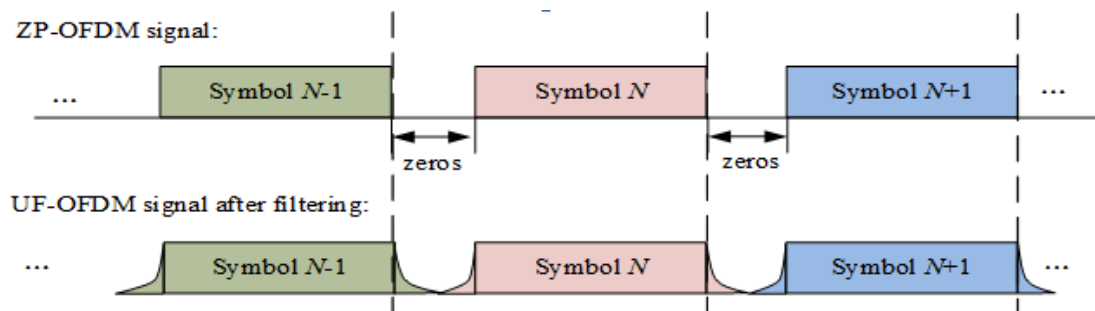

FIGURE 4.2: UFMC Symbol [17]

In UFMC, the filtering method proposed in the scientific papers [18][19][20], is a Dolph-Chebyshev filter due to its low side-lobes fall rate.

4.2 UFMC Transceiver Structure

Let's consider a simple one to one transmission in order to characterize our UFMC system. Suppose that we have N subcarriers allocated for transmission to the k -th user. The total N subcarriers are divided into B sub-bands. Suppose that there are M_i subcarriers in the i -th sub-band. Having these specifications the following formula should hold:

$$\sum_{i=1}^B M_i = N \quad (4.1)$$

In each sub-band is applied IFFT of length N , and filtering of length L . Hence, the data vector $x_{i,k}$ will have length $N+L-1$.

The final time-domain transmitted vector x_k to the k -th user would be a superposition of B sub-band filtered components:

$$x_k = \sum_{i=0}^B (x_{i,k} * f_{i,k}) \quad (4.2)$$

where $f_{i,k}$ is the filter for the i -th sub-band and $x_{i,k}$ is the data vector of the i -th sub-band after applying N point IFFT. We can write the equation 4.2 in a vectorial form by using the Toeplitz matrix for filtering operation and IDFT matrix for IFFT operation. Finally the UFMC signal for the k -th user can be written as:

$$x_k = \sum_{i=1}^B F_{i,k} V_{i,k} c_{i,k} \quad (4.3)$$

where $F_{i,k}$ is the Toeplitz matrix that contains the filter impulse responses performing the linear convolution and $V_{i,k}$ is the IDFT matrix which allocates the complex symbols c_i to the assigned subcarriers. Basically, the Toeplitz Matrix

will have the following form:

$$E_i = \begin{bmatrix} h[0] & 0 & 0 & \dots & 0 & 0 & \dots & 0 \\ h[1] & h[0] & 0 & \dots & 0 & 0 & \dots & 0 \\ h[2] & h[1] & h[0] & \dots & 0 & 0 & \dots & 0 \\ \vdots & \vdots & \vdots & \vdots & \vdots & \vdots & \vdots & \vdots \\ h[L-1] & h[L-2] & \dots & \dots & h[0] & 0 & \dots & 0 \\ \vdots & \vdots & \vdots & \vdots & \vdots & \vdots & \vdots & \vdots \\ 0 & 0 & 0 & \dots & h[L-1] & h[L-2] & \dots & h[0] \end{bmatrix}$$

It is worth mentioning that if the order of the filter $L=1$, UFMC converges to ZP-OFDM.

The block diagram of a UFMC transceiver is illustrated in figure 4.3.

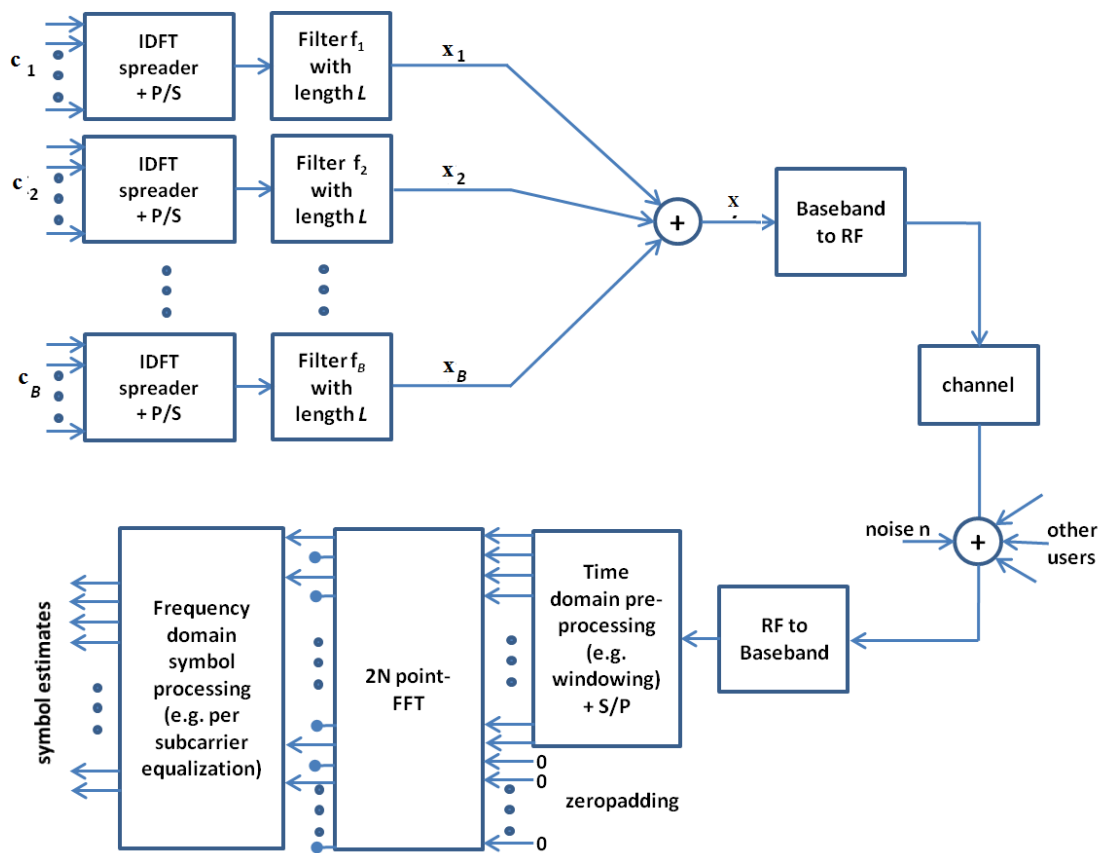

FIGURE 4.3: UFMC Block Diagram

At the receiver side, for complexity purposes, we have to zero pad the received signal to the next power of 2 and then perform FFT. This is due to the fact that

we usually apply a power of 2 point FFT or IFFT because it takes less time. After passing through filter the received signal would be of length $N+L-1$, where L is the delay of the filter (length of ZP) and N is a power of 2. Therefore, at the receiver we have to apply a $2N$ point FFT, which means an increased complexity compared with OFDM and f-OFDM. After applying FFT we have to apply some post processing like equalization and downsampling by a factor of 2, in order to get the transmitted UFMC signal. As in f-OFDM, the core of this technique is the filtering operation, therefore we should apply and build it in a proper way. The Dolph-Chebyshev filter is analyzed in the following section.

4.3 Doph-Chebyshev Window

There is a particular reason why we use Dolph-Chebyshev window in order to suppress the OOB emissions [18]. Given the desired side-lobe suppression, it gives the narrowest band possible. Or vice-versa, given the BW of the main lobe, it optimizes the OOB emissions. It minimizes the Chebyshev norm of the side lobes for a particular main lobe. The following equation characterize the optimal Dolph-Chebyshev window transform:

$$W(w_k) = \frac{\cos\{M\cos^{-1}[\beta\cos(\pi k/M)]\}}{\cosh[M\cosh^{-1}(\beta)]} \quad k = 0, 1, \dots, M - 1 \quad (4.4)$$

$$\beta = \cosh\left[\frac{1}{M}\cosh^{-1}(10^\alpha)\right], \quad \alpha \approx 2, 3, 4 \quad (4.5)$$

Now the Dolph-Chebyshev window is defined as:

$$w(n) = DFT\{W(w_k)\} \quad (4.6)$$

The α parameter effects the side-lobe level (SLS).

$$SLS_{dB} = -20\alpha \quad (4.7)$$

Usually, in this type of window the side lobes are called ripples in the stop-band because they have the same level of attenuation.

4.4 Numerical Results

In this section we are going to see the spectrum of an UFMC signal by performing the simulation of a simple point to point UFMC transceiver. Again the parameters of our transmission are going to be the same like in the case of OFDM and f-OFDM, in order to make a comparison of schemes. The following table summarizes all the parameters used.

| Parameter | Value based on Mobile WiMAX standard |
|------------------------------------|---|
| FFT/IFFT size | 512 |
| Number of used data subcarriers | 360 |
| Number of pilot subcarriers | 12 |
| Number of guard bands | 32 (6 percent) |
| Zero Padding | 1/8 |
| Channel Bandwidth (MHz) | 5 |
| Subcarrier frequency spacing (kHz) | 10.94 |
| Useful symbol time (micro s) | 91.4 |
| Modulation | QPSK |
| Channel model | AWGN |
| Coding rate | uncoded |
| Order of the filter M | 64 (1/8 of symbol time = ZP, -40dB sidelobes) |
| Number of sub-bands | 8 (64 sub-carriers/sub-band) |

TABLE 4.1: Simulation Parameters UFMC transceiver

Analyzing fig 4.4 we see that we have divided the 5MHz of BW into 8 smaller subbands and filtering them independently . We can distinguish that the effect of each subband on adjacent subbands is going to be low because the attenuation in the side lobes of each subband is high. The overall spectrum is shown in figure 4.5 when we see even the OOB emissions. A comparison between methods considering the spectrum is going to be made in the following chapter.

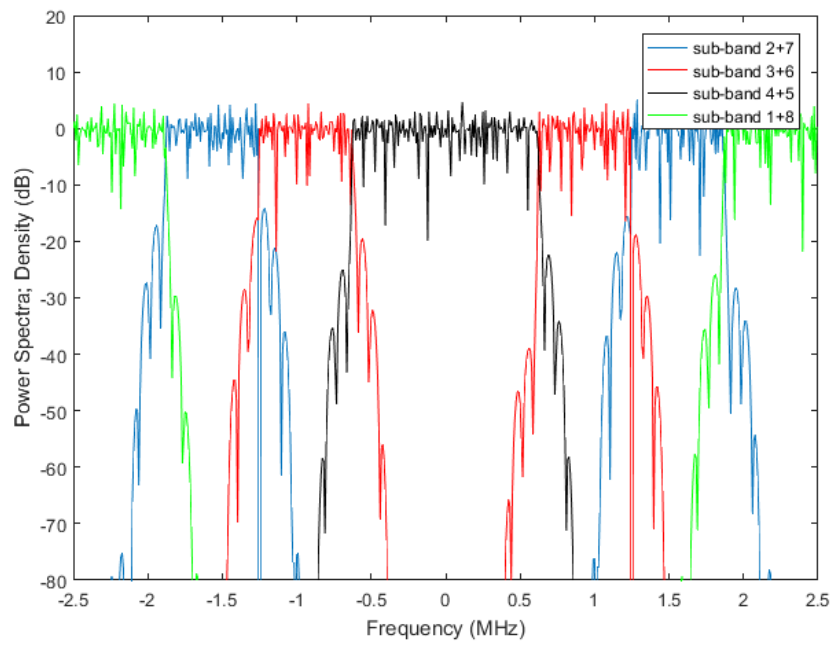

FIGURE 4.4: UFMC inBand Spectrum

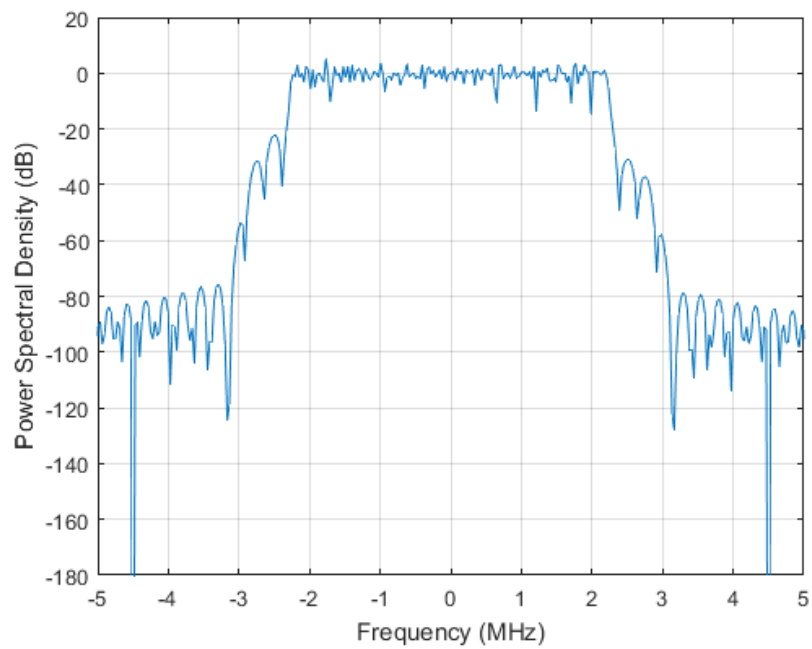

FIGURE 4.5: UFMC Spectrum

4.5 Summary

In this chapter the Unified Filtered Multi-carrier (UFMC) scheme was discussed. At the beginning of the chapter a general framework was explained, going on

with the block diagram of a UFMC transceiver. As this technique uses a Dolph-Chebyshev window to suppress the OOB E this type of window was analyzed. After performing some numerical simulations of a simple point to point UFMC transceiver the final result was shown.

Chapter 5

Performance Assessment

In the previous chapters, we focused our attention on the spectral properties of the considered waveforms. Our considerations were mainly focused on the overall picture of the transceiver of each scheme and the spectrum of the signal. We will see through this chapter some performance assessment of each scheme, based on simulation results using Matlab. We will perform our simulations, firstly by considering a synchronous transmission, going on with performance degradation evaluation due to Carrier frequency offset (CFO) [21].

5.1 Spectrum Comparison of OFDM, f-OFDM, UFMC

Firstly, let us start by comparing the results we obtained for the PSD of each signal, OFDM, f-OFDM and UFMC. We are going to put the results in the same plot, as shown in figure 5.1.

To begin with, we see that f-OFDM has the best localization in frequency. This is due to the fact that in these technique we are using long filtering, in contrast with UFMC where filter length should be the same as ZP. f-OFDM allows us to use a longer filter, because the waveform maintains the orthogonality in the frequency

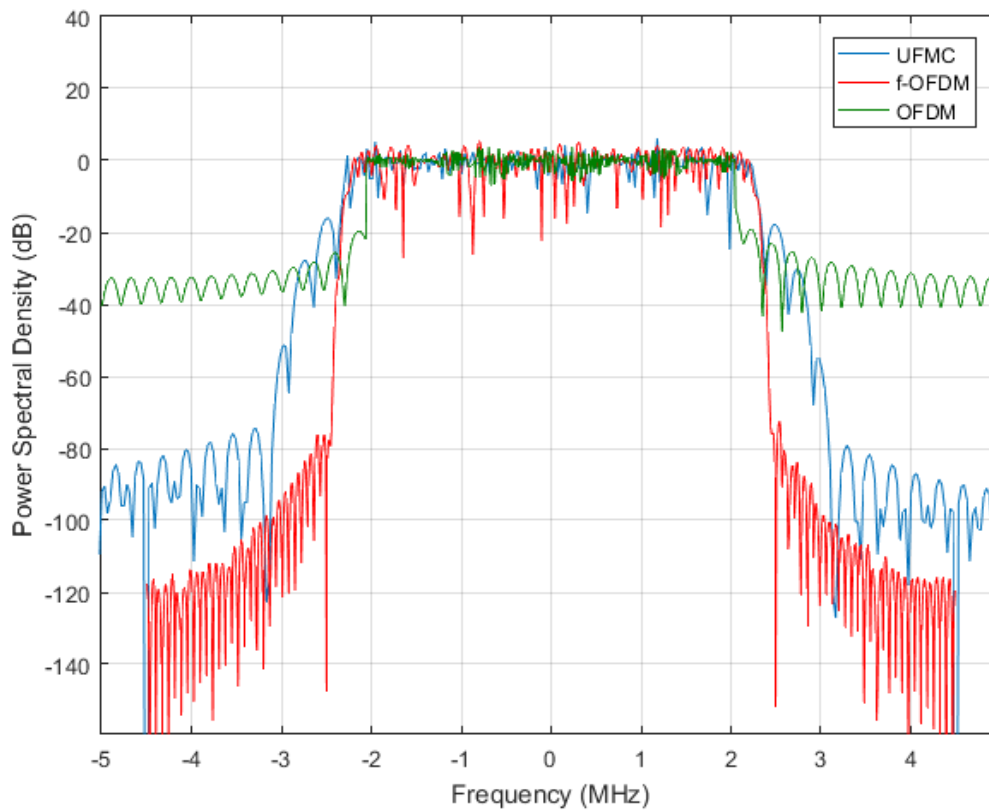

FIGURE 5.1: Spectrum Comparison

domain, by preserving the use of CP. On the other hand, in UFMC we intentionally remove the CP with the cost of having ICI. However, filtering operation in each subband makes the effect of the ICI self-introduced smaller.

Secondly, we can distinguish that the BW of f-OFDM and UFMC is larger compared with that of OFDM. This happens because we are using less guard bands compared with OFDM, which according to the parameters that we have run the simulations is 18% of the 5MHz BW assigned. Whereas in f-OFDM and UFMC we are using a smaller guard band, approximately 6%. Therefore f-OFDM and UFMC utilize the spectrum more efficiently compared with OFDM.

Finally, if we consider an asynchronous up-link scenario [22][23] of OFDM, f-OFDM and UFMC, by intuition we can understand that f-OFDM and UFMC would overperform OFDM due to their well localization in frequency.

5.2 Performance Analysis in Synchronous Transmission

We are going to measure the performance in terms of bit error rate (BER) vs E_b/N_0 over a AWGN channel for OFDM, f-OFDM and UPMC. The simulation of all the 3 schemes is done in Matlab, following the parameters according to table 5.1.

| Parameter | OFDM, f-OFDM, UPMC |
|------------------------------------|---------------------------|
| FFT/IFFT size | 512 |
| Number of used data subcarriers | 360 |
| Number of pilot subcarriers | 12 |
| Number of guard bands | 94, 32, 32 |
| CP or ZP | 1/8 |
| Channel Bandwidth (MHz) | 5 |
| Subcarrier frequency spacing (kHz) | 10.94 |
| Useful symbol time (micro s) | 91.4 |
| Modulation | QPSK |
| Channel model | AWGN |
| Coding rate | uncoded |
| Order of the filter M | no filter, 127, 64 |
| Number of sub-bands | no subband, no subband, 8 |

TABLE 5.1: Simulation Parameters

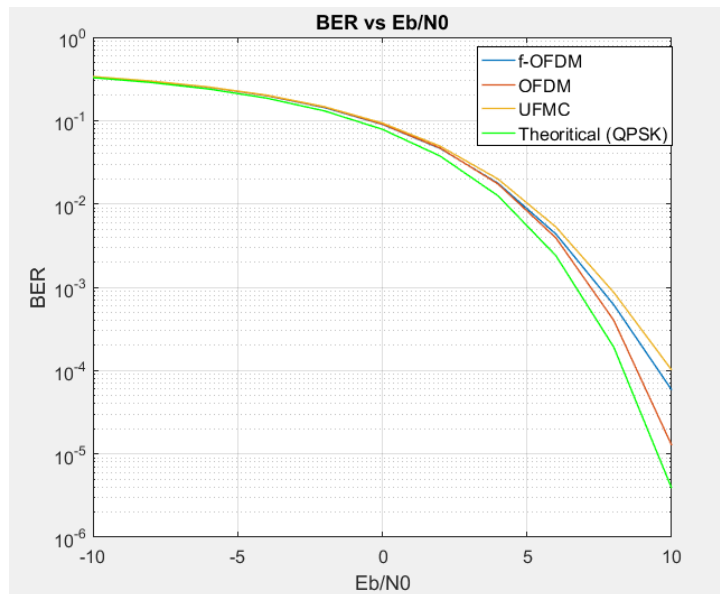

FIGURE 5.2: Performance Comparison

It is obvious from figure 5.2 that in a AWGN channel the performance of UFMC and f-OFDM is slightly lower than OFDM. This is due to the fact that the filter induces some ripples in the passband and will cause a small distortion in the symbol transmitted. The symbols in f-OFDM are less distorted from the passband ripples of the filter because the filter length is higher than UFMC. It is also worth noticing that the performance of OFDM is slightly lower than the theoretical one due to the CP. However, we have to keep in mind that in this simulation we do not have any kind of time offset, frequency offset or phase offset. Apart from the AWGN noise, the other parameters are ideal.

5.3 Performance Analysis in Presence of Carrier Frequency Offset

Let us now turn the attention on the effect of a CFO in the performance of OFDM, f-OFDM, UFMC. The carrier frequency offset is normalized to the frequency spacing. It means that a $CFO = 0.2 = 0.2 * \Delta f$. We will show below the results that we obtain by keeping the same parameters as in section 5.2.

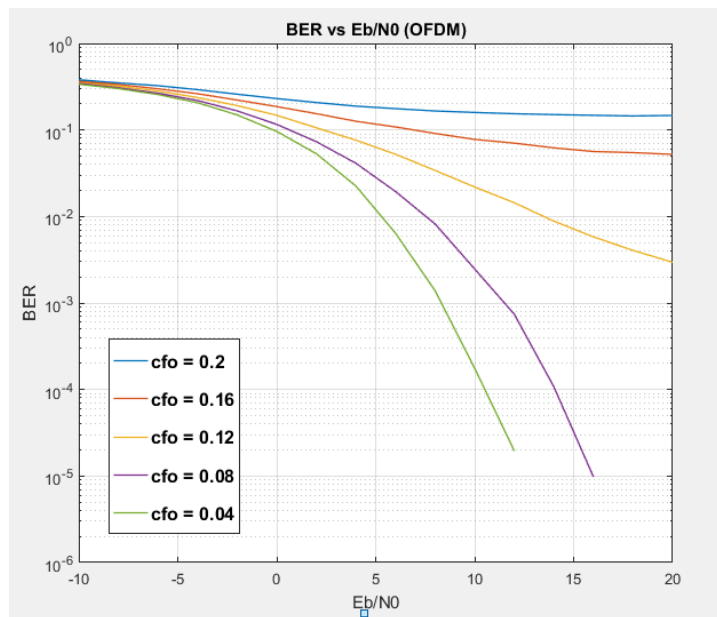

FIGURE 5.3: OFDM performance in presence of CFO

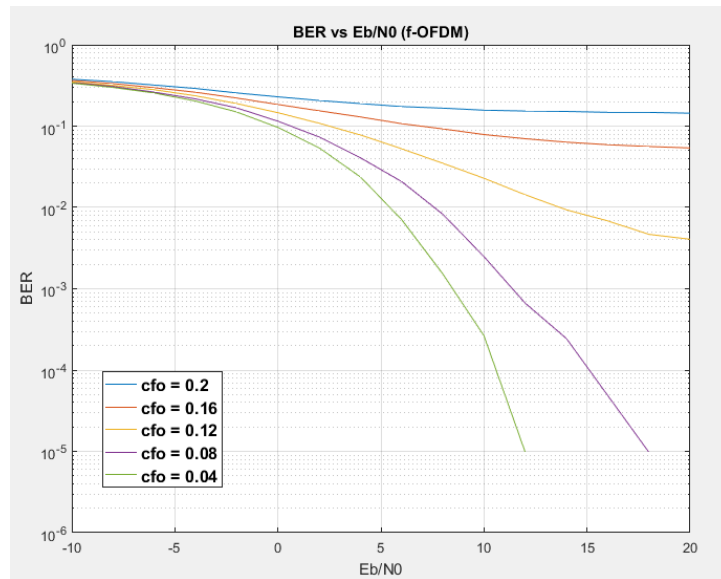

FIGURE 5.4: f-OFDM performance in presence of CFO

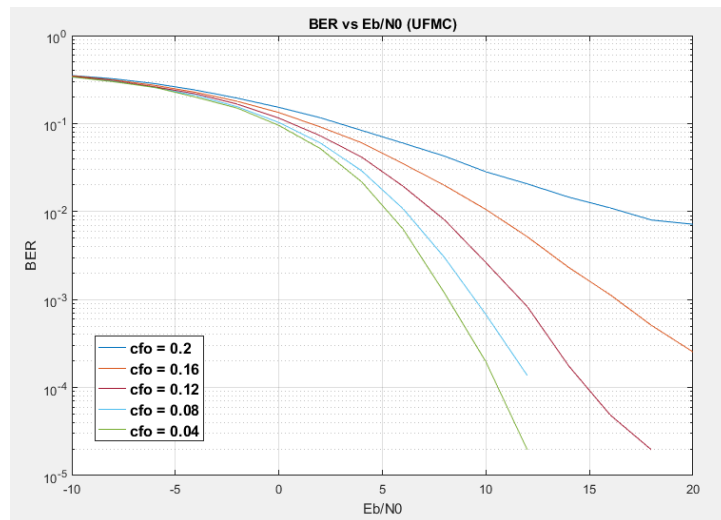

FIGURE 5.5: UFMC performance in presence of CFO

It is perfectly shown that UFMC is more robust towards CFO than the two other schemes. On the other hand, OFDM and f-OFDM have the same performance when the CFO is present because we are considering only a one-to-one communication. The OOB emissions suppressed by the filter in f-OFDM, does not give us any gain in a one-to-one scenario. It is important to understand that in an up-link scenario, where many UE send data to the BS, f-OFDM will outperform OFDM in an asynchronous transmission.

Furthermore, in UFMC as the filtering is applied in several subbands inside the

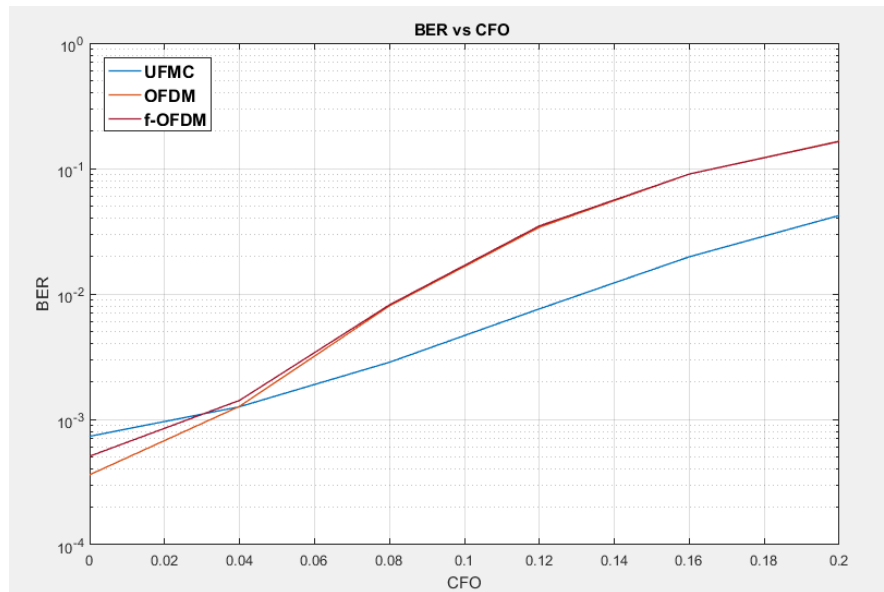

FIGURE 5.6: Performance Comparison BER vs E_b/N_0

band, the effect of a CFO will impose a lower effect in terms of performance degradation. This is even the reason why we discard the use of a CP, because wasting the orthogonality in frequency domain has a lower impact on the performance. This is also shown in figure 5.6 where we have plotted the result by fixing $E_b/N_0 = 8dB$ and applying different values of CFO.

Chapter 6

Conclusions

In this chapter it will be presented a brief summary of all the thesis project. The conclusions of the work are going to be mentioned and emphasized. Lately, we will discuss the future lines of study.

6.1 Thesis Summary

This thesis work was mainly focused on the evaluation of OFDM-based modulation schemes for future wireless communication. The modulation schemes we took into consideration were f-OFDM and UFMC. In order to enter in more details in each scheme, we started from the complete and detailed picture of OFDM. Furthermore, f-OFDM and UFMC were discussed in different chapters, starting from general framework and going on with the mathematical representation of each signal. The block diagram of each scheme was provided and the simulation results of the OFDM, f-OFDM and UFMC signal spectrum were shown. Then we made a performance assessment of each modulation scheme in a synchronous and asynchronous case, taking into account a point-to-point communication scenario.

6.2 Conclusions

To conclude, we will discuss the results we obtained through this thesis in terms of the following features:

- Complexity

Both schemes f-OFDM and UFMC offer lower complexity transmitter and receivers. Even though they introduce the presence of filter, less complex receivers are needed because the need for algorithms to perform strict synchronization is relaxed.

- Spectral Containment

The spectral containment of f-OFDM and UFMC is improved, compared with OFDM. F-OFDM outperforms UFMC in terms of attenuation in the stopband because it uses a longer filter. Therefore F-OFDM is better localized in frequency than UFMC.

- Robustness against CFO

UFMC is more robust against CFO than OFDM and f-OFDM in a one-to-one scenario transceiver.

- Asynchronous Transmission

Both techniques support asynchronous transmission because they are better localized in frequency and the performance degradation due to imparities is lower.

- Flexible Numerology

F-OFDM and UFMC offer flexible numerology due to the filtering operation that makes this waveforms flexible and re-configurable depending on the scenario.

6.3 Future Work

In this thesis the performance evaluation was only made considering a simple one-to-one communication. The results obtained are valuable. However a further performance assessment should be considered taking into consideration an up-link scenario communication. Furthermore, different kind of channel can be tried in order to see the robustness in different channel conditions.

Secondly, we have performed filtering in f-OFDM based on soft-truncated filter and in UFMC based on Dolph-Chebyshev filter. However other type of filters can be taken into account. There can be other filtering techniques that can offer better results.

Finally, other techniques like Filter Bank Multi-carrier (FBMC) and Generalized Frequency Division Multiplexing (GFDM) can be evaluated.

Bibliography

- [1] Qualcomm Incorporated. Waveform requirements. *3GPP TSG RAN WG1 Meeting, Korea*, April 2016.
- [2] P. Banelli, S. Buzzi, G. Colavolpe, A. Modenini, F. Rusek, and A. Ugolini. Modulation formats and waveforms for 5g networks: Who will be the heir of ofdm: An overview of alternative modulation schemes for improved spectral efficiency. *IEEE Signal Processing Magazine*, 31:80–93, November 2014.
- [3] Rohde & Schwarz. 5g waveform candidates, June 2016. URL https://cdn.rohde-schwarz.com/pws/dl_downloads/dl_application/application_notes/1ma271/1MA271_0e_5G_waveform_candidates.pdf.
- [4] URL https://www.ngmn.org/fileadmin/ngmn/content/images/events/other_events/2015/5G_Spectrum_Recommendations_White_Paper_.pdf.
- [5] Chih-Lin I, S. Han Z. Xu, S. Wang, Q. Sun, and Y. Chen. New paradigm of 5g wireless internet. *IEEE Journal on Selected Areas in Communications*, 34:474–482, March 2016.
- [6] H. Lin. Flexible configured ofdm for 5g air interface. *IEEE Access*, 3:1861–1870, September 2015.
- [7] G. Berardinelli, K. Pajukoski, E. Lahetkangas, R. Wichman, P. Mogensen, and O. Tirkkonen. On the potential of ofdm enhancements as 5g waveforms. *Vehicular Technology Conference (VTC Spring), IEEE*, May 2014.
- [8] METIS. URL <https://www.metis2020.com/>.
- [9] 5GNOW. URL <http://www.5gnow.eu/>.
- [10] A. R. S. Bahai, B. R. Saltzberg, and M. Ergen. *Multi-Carrier Digital Communications Theory and Applications of OFDM*. Springer, 2004.
- [11] J. G. Andrews, S. Buzzi, W. Choi, S. V. Hanly, A. Lozano, and A. C. K. Soong. What will 5g be. *IEEE Journal on Selected Areas in Communications*, 32:1065–1082, June 2014.
- [12] X. Zhang, M. Jia, L. Chen, J. Ma, and J. Qiu. Filtered-ofdm - enabler for flexible waveform in the 5th generation cellular networks. *Global Communications Conference (GLOBECOM), IEEE*, December 2015.

-
- [13] A. Antoniou. *Digital Signal Processing, SIGNALS, SYSTEMS AND FILTERS*. McGraw-Hill, 2006.
- [14] A. Sahin, I. Guvenc, and H. Arslan. A survey on multicarrier communications: Prototype filters, lattice structures, and implementation aspects. *IEEE Communications & Surveys Tutorials*, 16:1312–1338, December 2014.
- [15] J. Abdoli, M. Jia, and J. Ma. Filtered ofdm: A new waveform for future wireless systems. *Signal Processing Advances in Wireless Communications (SPAWC), IEEE*, July 2015.
- [16] B. Farhang-Boroujeny. Ofdm versus filter bank multicarrier. *IEEE Signal Processing Magazine*, 28:92–112, May 2011.
- [17] HiSilicon Huawei. Ofdm based flexible waveform for 5g. *3GPP TSG RAN WG1 Meeting, Korea*, April 2016.
- [18] M. Mukherjee, L. Shu, V. Kumar, P. Kumar, and R. Matam. Reduced out-of-band radiation-based filter optimization for ufmc systems in 5g. *Wireless Communications and Mobile Computing Conference (IWCMC)*, August 2015.
- [19] T. Wild, F. Schaich, and Y. Chen. 5g air interface design based on universal filtered (uf-)ofdm. *Digital Signal Processing (DSP), 19th International Conference*, August 2014.
- [20] F. Schaich and T. Wild. Waveform contenders for 5g ofdm vs. fbmc vs. ufmc. *Communications, Control and Signal Processing (ISCCSP), 6th International Symposium*, May 2014.
- [21] A. Aminjavaheri, A. Farhang, A. RezazadehReyhani, and B. F. Boroujeny. Impact of timing and frequency offsets on multicarrier waveform candidates for 5g. *Signal Processing and Signal Processing Education Workshop (SP/SPE), IEEE*, August 2015.
- [22] V. Vakilian, T. Wild, F. Schaich, S. ten Brink, and J. F. Frigon. Universal-filtered multi-carrier technique for wireless systems beyond lte. *Globecom Workshops (GC Wkshps), IEEE*, December 2013.
- [23] H. Kim, J. Bang, S. Choi, and D. Hong. Resource block management for uplink ufmc systems. *Wireless Communications and Networking Conference (WCNC), IEEE*, April 2016.