

Abstract

This paper presents an energy-efficient computer vision processor for a navigation device for the visually impaired. Utilizing a shared parallel datapath, out-of-order processing and co-optimization with hardware-oriented algorithms, the processor consumes 8mW at 0.6V while processing 30 fps input data stream in real time. The test chip fabricated in 40nm is demonstrated as a core part of a navigation device based on a ToF camera, which successfully detects safe areas and obstacles.

A 0.6V, 8mW 3D Vision Processor for a Navigation Device for the Visually Impaired

Dongsuk Jeon^{1,2}, Nathan Ickes¹, Priyanka Raina¹, Hsueh-Cheng Wang¹, Daniela Rus¹, and Anantha P. Chandrakasan¹

¹Massachusetts Institute of Technology, Cambridge, MA

²Seoul National University, Suwon, Korea

3D imaging devices, such as stereo and time-of-flight (ToF) cameras, measure distances to the observed points and generate a depth image where each pixel represents a distance to the corresponding location. The depth image can be converted into a 3D point cloud using simple linear operations. This spatial information provides detailed understanding of the environment and is currently employed in a wide range of applications such as human motion capture [1]. However, its distinct characteristics from conventional color images necessitate different approaches to efficiently extract useful information.

This paper describes a low-power vision processor for processing such 3D image data. The processor achieves high energy efficiency through a parallelized reconfigurable architecture and hardware-oriented algorithmic optimizations. The processor will be used as a part of a navigation device for the visually impaired (Fig.1). This handheld or body-worn device is designed to detect safe areas and obstacles and provide feedback to a user. We employ a ToF camera as the main sensor in this system since it has a small form factor and requires relatively low computational complexity [2].

The point cloud (converted in software from the raw depth image) is first reoriented based on the pitch and roll angles of the camera, as measured by an inertia measurement unit (IMU) in real time. We then apply a dynamic frame skipping algorithm, which significantly reduces power consumption by skipping processing of frames which are sufficiently similar to the previous frame. The frame-skipping algorithm divides the entire frame into multiple blocks and calculates the average depth of each block. If the number of blocks with significant depth changes does not exceed a threshold value, the processor skips all further processing of this frame and generates a frame skip signal. The frame skip signal can be used as feedback to control the frame rate of the ToF camera itself. The proposed algorithm was measured to reduce the number of frames processed by 69% in test cases of navigating through an indoor environments with variable paces.

The obstacle detection algorithm we employ is based on plane categorization. In indoor environments, artificial objects generally possess one or more perceptible planes and we utilize this property to detect obstacles. The main processing stage calculates the surface normal at each point in the cloud [3] and classifies each point as horizontal, vertical or intermediate. Post-processing filters and sub-samples this annotated cloud to reduce noise of the 3D imaging sensor. The processor then applies a plane segmentation algorithm based on region growing which groups similar neighboring points. From the extracted planes, we can differentiate the ground plane at a specific height, which is considered safe for the user to walk on, from other obstacles. The plane segmentation data can also provide information for other applications such as identifying regions of interest for object recognition. Finally, the processor calculates the distance to the closest obstacle in several different directions and sends it as a feedback so that the user can sense the environment and navigate avoiding obstacles without a cane.

The architecture of the processor is detailed in Fig. 2. It consists of 2 memory banks totaling 163kB; one each for the first 2 processing stages and post-processing. The design has a shared datapath which is reconfigured to accommodate different parts of the processing flow with minimal hardware overheads and energy consumption. The datapath includes multiple arithmetic unit banks for parallel 16-bit ADD, SUB, MULT and DIV operations, which provide enough throughput to process input data stream in real time. In addition, the block floating point blocks take a key role in mapping long operands onto the given fixed-point datapath by dynamically changing data scale without significant accuracy degradation. These blocks observe a set of operands and move the binary point location appropriately so that 16 MSBs excluding sign extension are preserved in the largest value. Fig. 3 shows the datapath configuration for the surface normal calculation and plane classification portions of the main processing. The colored blocks are the arithmetic blocks in the datapath. Some of the blocks are not required to be active on every cycle and hence are time-shared (colored yellow).

Since the surface normal calculation is one of the computation bottlenecks, we further parallelized it to process 2 locations simultaneously. However, the size of the calculation window changes based on the actual input data, making memory access patterns unpredictable and causing stalls due to memory access conflict. To address this, we implemented an out-of-order processing architecture shown in Fig. 4. The integral image block is divided into two banks storing even and odd rows. The width of the calculation window w_k at each calculation point y_k determines which bank the datapath needs to

access. The processor puts read addresses into one of two address FIFOs accordingly. Since each FIFO has a dedicated access to the corresponding integral image memory bank, two points can be processed at a time in out-of-order fashion unless one of the FIFOs becomes empty, which occurs infrequently when the number of even and odd memory accesses are similar on average. The proposed architecture increases throughput by 11% in simulation compared to in-order parallelization. This technique can also be directly applied to other algorithms that require extensive accesses to integral image memory such as SURF and Haar-like features [4, 5].

The annotated cloud is subsequently filtered and sub-sampled to reduce noise of the input cloud. The processor groups adjacent points that belong to the same plane type into larger planes using region growing based on [6]. The original algorithm launches search processes at arbitrary seed points and expands the current region by comparing with neighboring points in any direction. This incurs multiple comparisons especially for the points near the borders of different regions, and hence it requires excessive memory access operations and increases computation time. The arbitrary memory access pattern also impedes improving hardware efficiency further with a tailored architecture. Therefore, we developed a single pass region growing scheme depicted in Fig. 5. Instead of selecting among stored seeds, it starts at the top left point of the cloud and continues to the right pixel in the same row. Each point is only compared with the top and left points and merged to an existing region if they have similar properties such as normal vector. Note that two connected regions may not be merged until processing reaches specific location (*e.g.* region #1 and #5). We store the list of connected regions in a separate table so that they can ultimately be merged into a single plane. This scheme ensures that all of the points are accessed only twice throughout the search process and provides additional possibility of hardware optimization due to fixed memory access pattern, while producing exactly same results as the original algorithm. In simulation, the proposed algorithm reduces both computation time and memory accesses by 30%.

The vision processor was fabricated in 40nm CMOS process. It consumes 8mW at 0.6V, 50MHz while processing a 30fps input stream. Fig. 6 shows a prototype of the complete navigation device consisting of ToF camera, IMU, ARM processor, and the fabricated vision processor. It successfully detects obstacles and calculates safe distances in multiple directions while correcting for camera position based on the posture data from the IMU. The processor achieves more than 2 orders of magnitude better energy efficiency than a 1.7GHz quad-core ARM Cortex-A9 processor. The largest energy savings result

from the dedicated architecture, and additional savings result from the architecture optimization techniques such as out-of-order pipelining.

Acknowledgement

We thank Texas Instruments for funding and the TSMC University Shuttle Program for chip fabrication. We are also grateful to the Andrea Bocelli foundation for providing the important challenges that motivated this work. The authors thank Prof. Laura Giarré for valuable discussions.

References

- [1] H. Zhang et al., "Adaptive Human-Centered Representation for Activity Recognition of Multiple Individuals from 3D Point Cloud Sequences," *IEEE Int. Conf. on Robotics and Automation*, pp. 1991-1998, May 2015.
- [2] J. Cho et al., "A 3-D Camera With Adaptable Background Light Suppression Using Pixel-Binning and Super-Resolution," *IEEE J. Solid-State Circuits*, vol. 49, no. 10, pp. 2319-2332, Oct. 2014.
- [3] S. Holzer et al., "Adaptive neighborhood selection for real-time surface normal estimation from organized point cloud data using integral images," *IEEE/RSJ Int. Conf. on Intelligent Robots and Systems*, pp. 2684-2689, Oct. 2012.
- [4] Y. Hanai et al., "A Versatile Recognition Processor Employing Haar-Like Feature and Cascaded Classifier," *ISSCC Dig. Tech. Papers*, pp. 148-149, Feb. 2009.
- [5] X. Wen et al., "Efficient Feature Selection and Classification for Vehicle Detection," *IEEE Trans. Circuits and Systems for Video Technology*, vol. 25, no. 3, pp. 508-517, Mar. 2015.
- [6] L. Zhu et al., "Automatic Segmentation of the Left Atrium from MR Images via Variational Region Growing With a Moments-Based Shape Prior," *IEEE Trans. Image Processing*, vol. 22, no. 12, pp. 5111-5122, Dec. 2013.

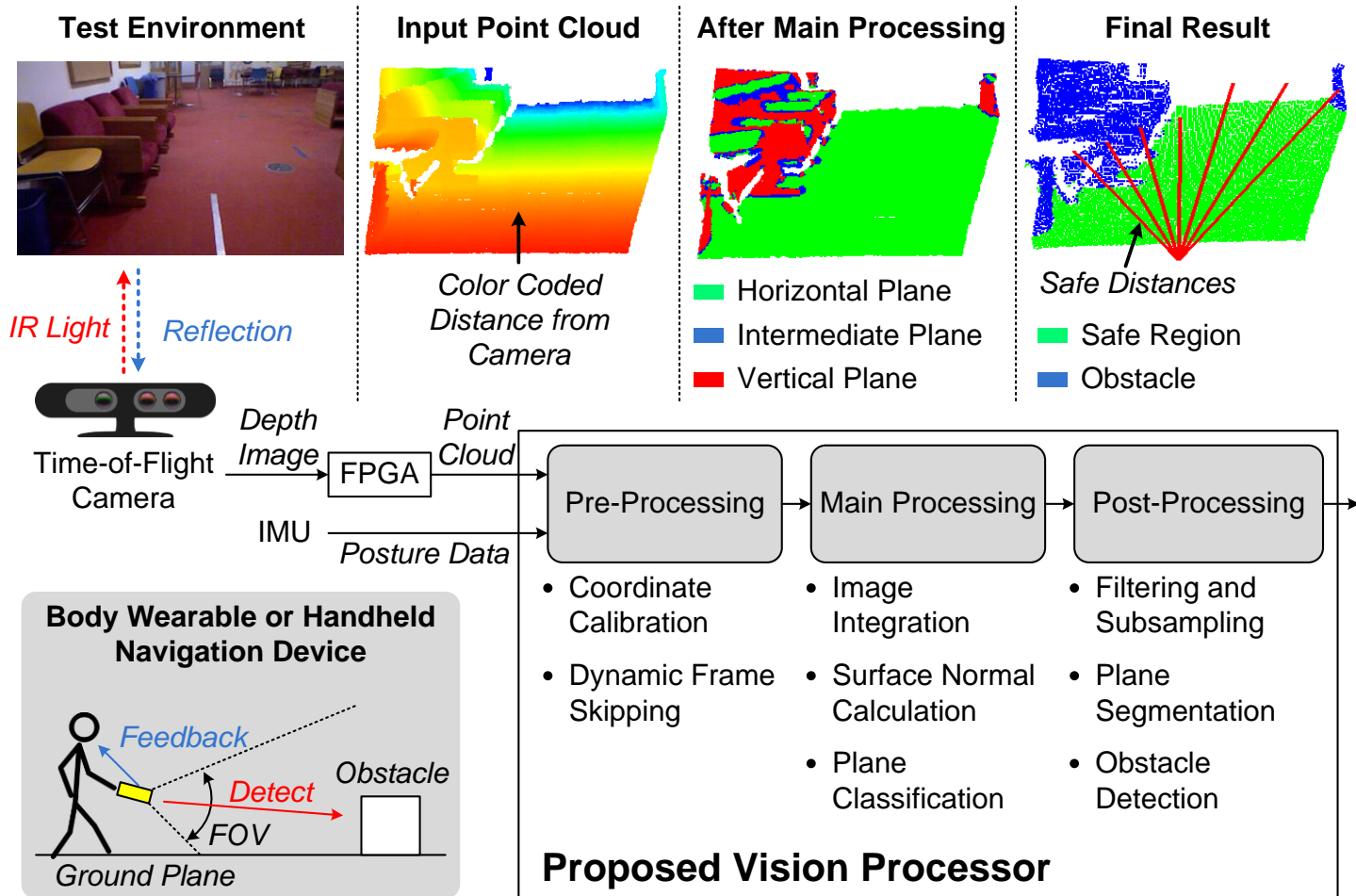

Figure 1. Overview of a navigation device for the visually impaired. The device is designed as a body wearable or handheld system which can replace a conventional cane.

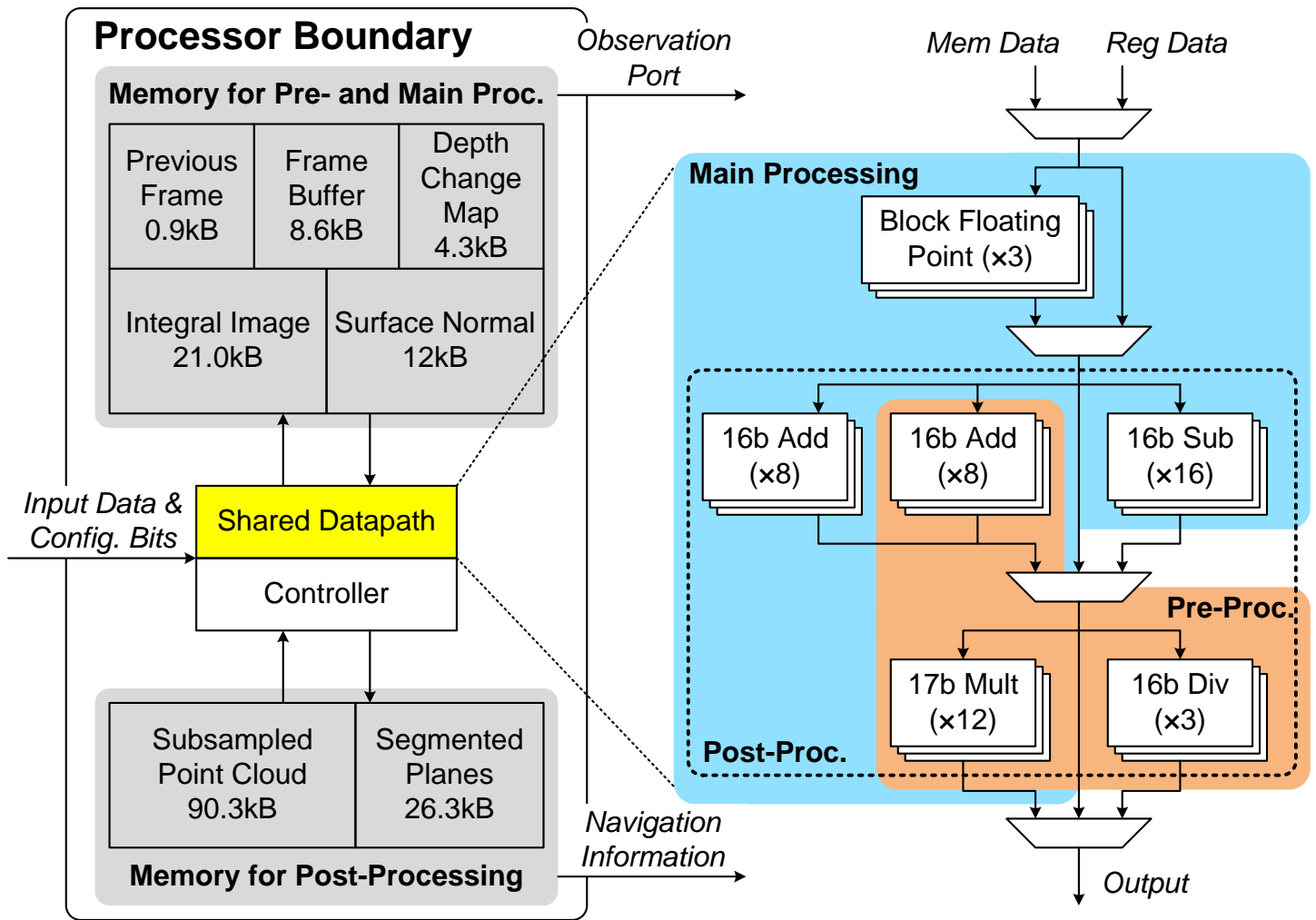

Figure 2. Architecture of the processor chip, showing the shared datapath that can accommodate all required computations with minimal reconfiguration and provide high throughput through parallelization.

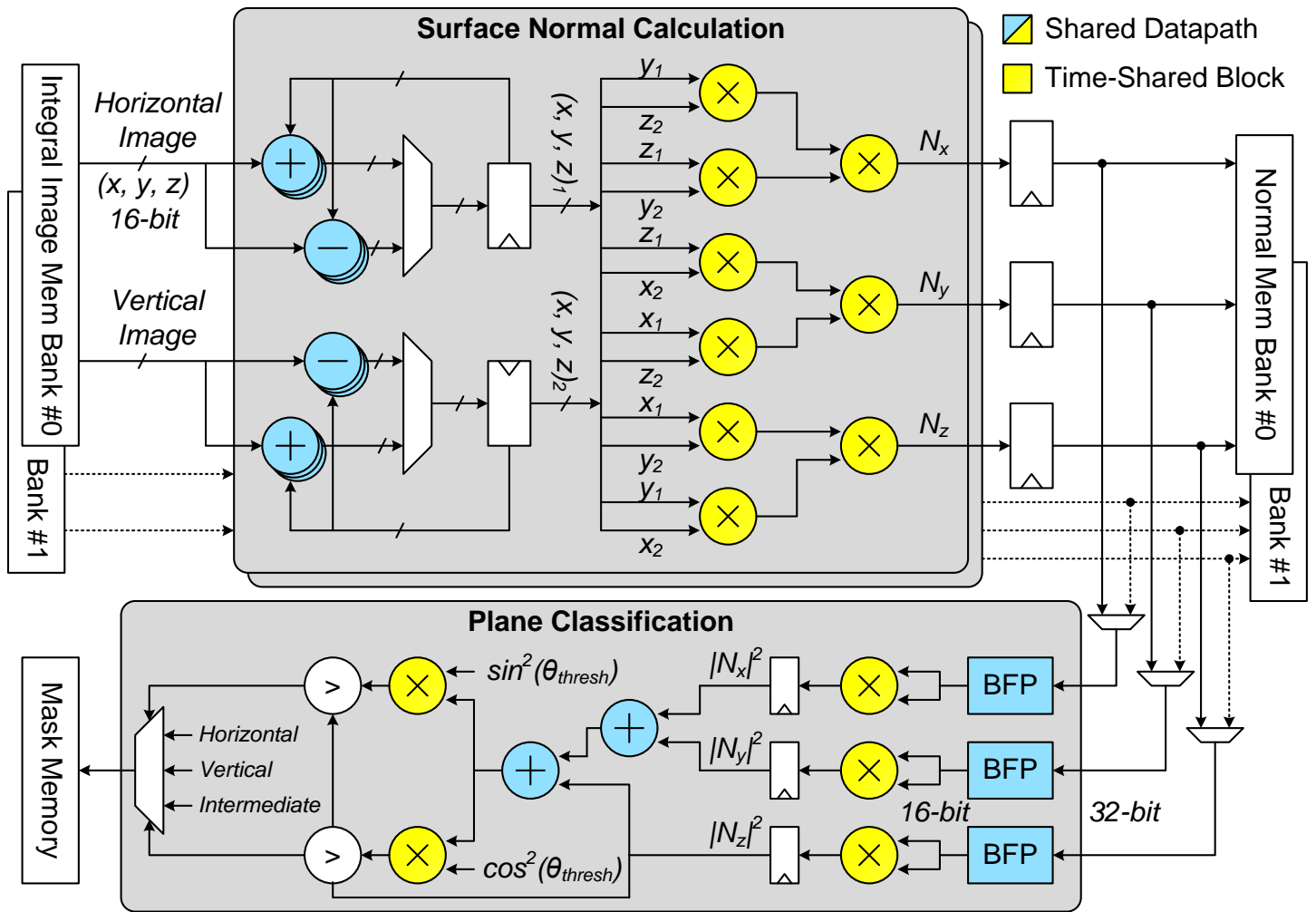
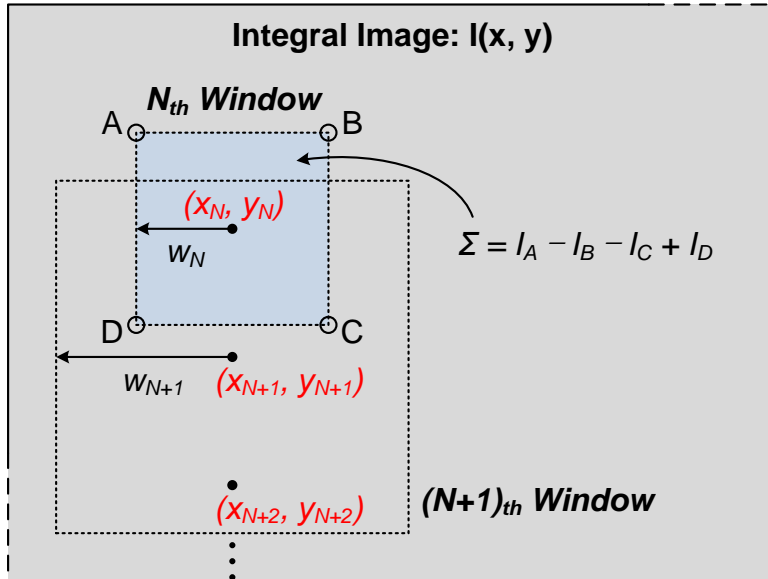
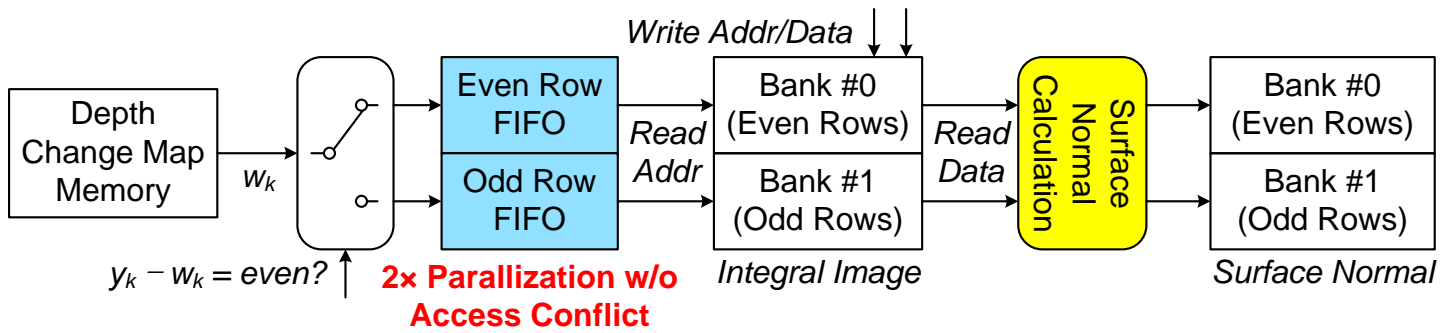

Figure 3. The shared datapath shown configured for surface normal and plane classification operations. Blue and yellow colored arithmetic blocks represent reconfigured elements of the shared datapath, where the yellow colored blocks are time-shared between two operations.



- (x_k, y_k) Locations of surface normal calculation
(Fixed)
- w_k Window size at each location
(Variable)
- $(x_k \pm w_k, y_k \pm w_k)$ Actual read addresses of integral image memory
(Variable)

Figure 4. The out-of-order surface normal computation scheme is shown. Since the width of processing window varies arbitrarily, read addresses of the integral image memory are selectively pushed into one of two FIFOs. The FIFOs increase throughput by 11% compared to in-order parallelization by averaging unbalanced access pattern over time.

Conventional Region Growing

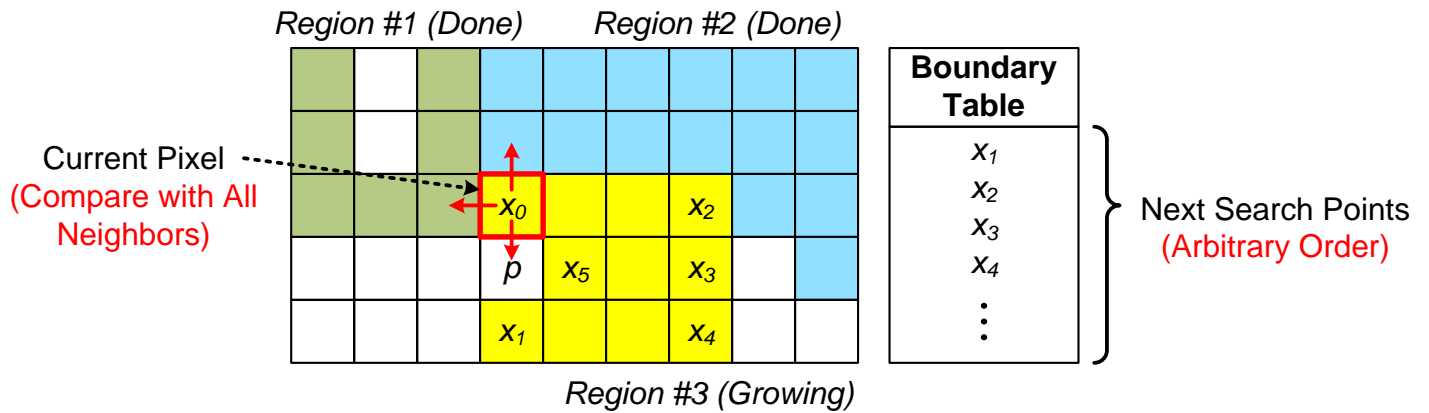

Single Pass Region Growing

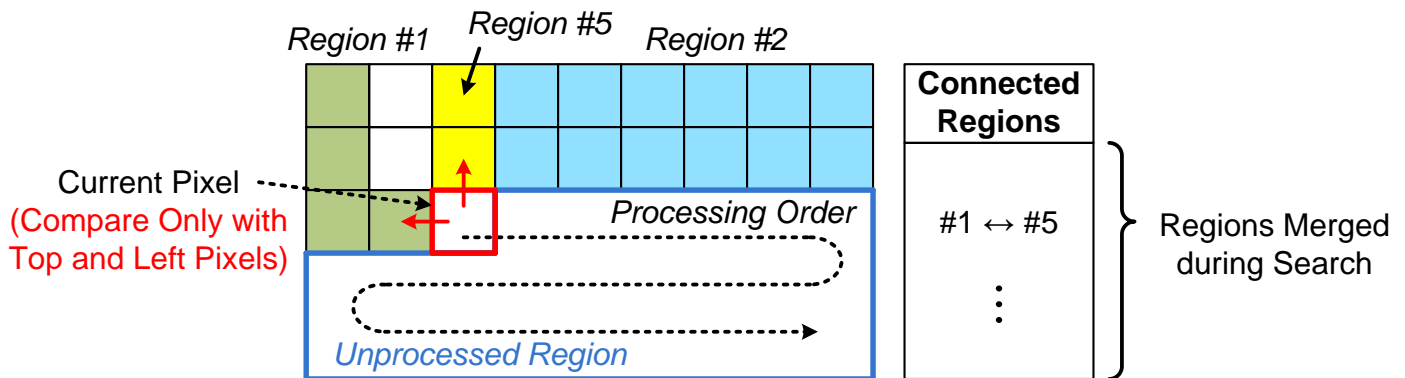

Figure 5. Comparisons between conventional and proposed single-pass region growing algorithms. A fixed search pattern in the single-pass algorithm removes unnecessary pixel comparisons and hence reduces both the number of memory accesses and the computation time by 30% in simulation.

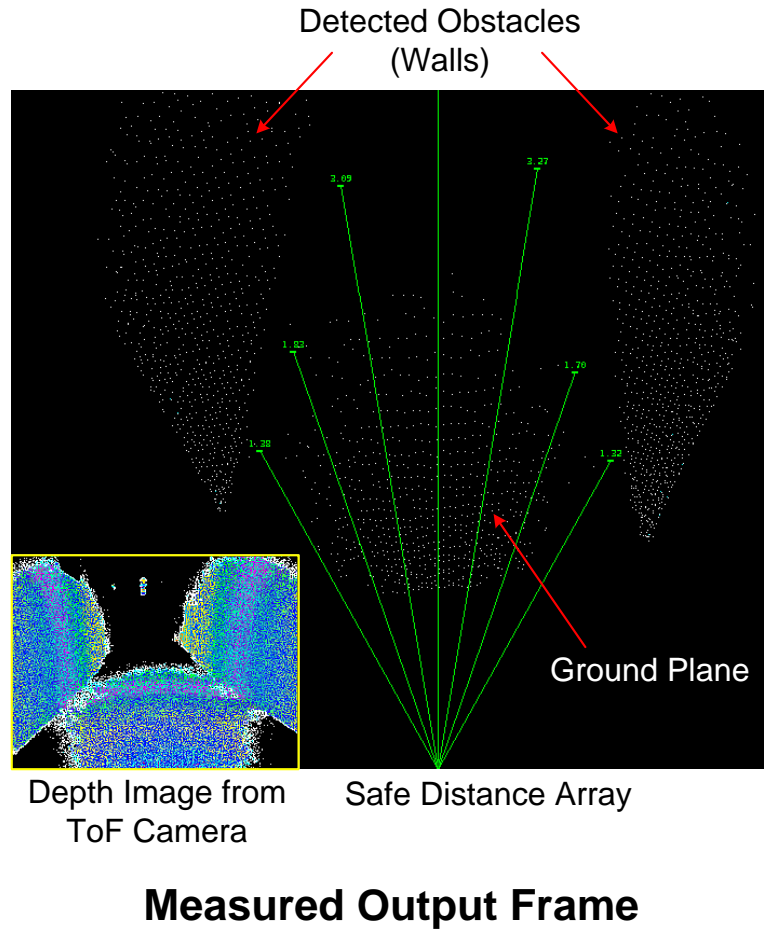
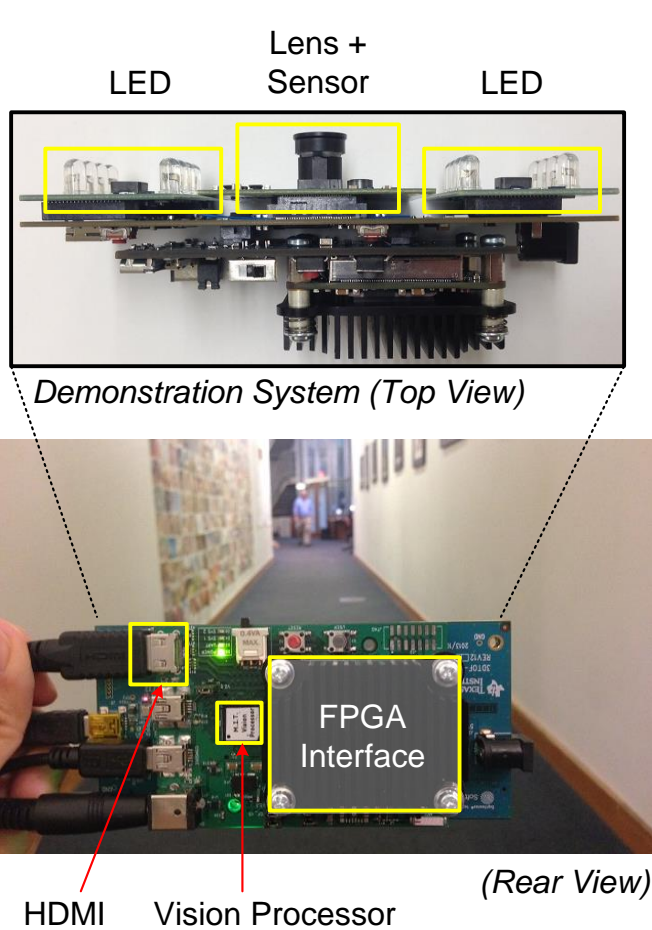
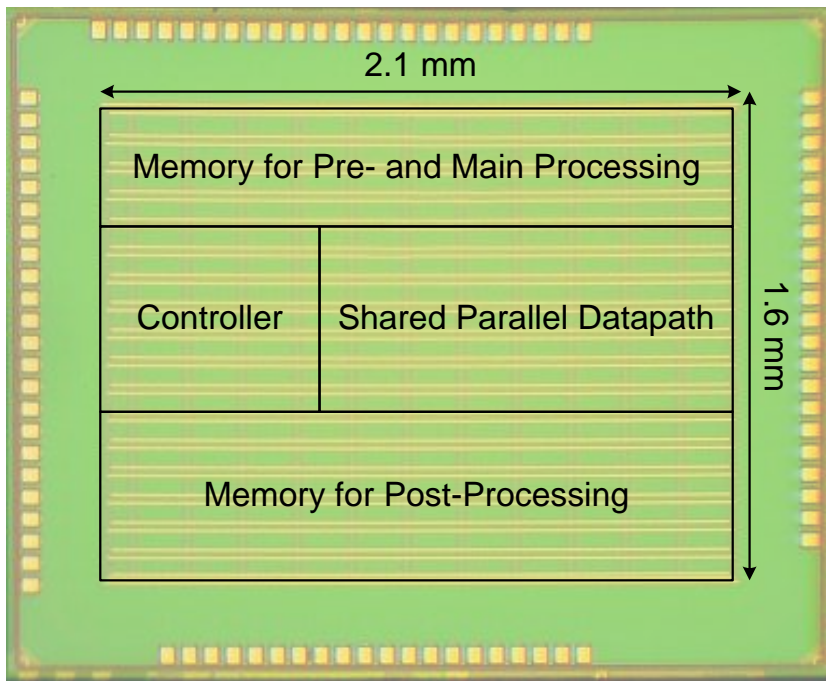

Figure 6. A navigation device using the fabricated processor is demonstrated. A ToF camera is on one side, and the processor and other peripherals are mounted on the other side. Measurement results show that the processor successfully detect obstacles (walls) on both sides in a long corridor and consequently generate longer safe distances toward free space in front.



Process	40nm CMOS
V_{DD}	0.6 V
Input Resolution	QVGA ~ HD
Output Resolution	QQVGA ~ QVGA
Clock Freq.	50 MHz
Power	8 mW
Performance	30 fps (@ QVGA)
Efficiency	270 μ J/frame
Search Directions	Up to 16

Figure 7. Die photo and a performance summary table for the processor.