

Architecture and System Analysis of Microgrids with Peer-to-Peer Electricity Sharing to Create a Marketplace which Enables Energy Access

Wardah Inam¹, Daniel Strawser¹, Khurram K. Afridi², Rajeev J. Ram¹, and David J. Perreault¹

¹Massachusetts Institute of Technology, Cambridge, Massachusetts, US

²University of Colorado Boulder, Boulder, Colorado, US

Abstract—More than 1.3 billion people in the world lack access to electricity and this energy poverty is a major barrier to human development. This paper describes a new concept of peer-to-peer electricity sharing which creates a marketplace for electricity. In this marketplace, the people who can afford power generating sources such as solar panels can sell electricity to people who are unable to afford generating sources or who might have access to electricity but require more electricity at certain times. These ad-hoc microgrids created by sharing of resources provide affordable electricity and are enabled by a Power Management Unit (PMU) described in this paper.

Index Terms—Dc microgrids, energy access, Power management Unit

I. INTRODUCTION

The lack of electricity is one of the most pressing concerns in the developing world. Today, about one out of every 5 people, i.e. more than 1.3 billion people in the world, do not have access to electricity and are denied a basic standard of living [1]. This deficiency impedes most aspects of human development: health, education and economic development.

While there is a pressing need to provide electricity access, the current technologies have not been able to scale to serve these areas. In developing countries, grid electricity is often unreliable or unavailable. The governments of these countries do not have the financial resources to increase generation to meet increasing demand, let alone to electrify off-grid areas. Also, grid extension to small remote areas can be very expensive [2]. Individual systems (such as solar home systems and diesel generators) have seen growth in recent years due to ease of deployment [3]. However, they are very expensive and require complex financing solutions. Moreover, it is difficult to extend their operation beyond what they have been originally designed for (usually only lighting and cellphone charging). Recently, microgrids have received more attention, especially in the developing world, due to their relatively low cost of electricity achieved by aggregate generation [4]. However, microgrid development has its own challenges. Microgrids have a high capital cost so are difficult to finance. Also, they traditionally require a rigorous planning process as a large percentage of the community needs to be convinced to use this service for it to make financial sense.

This paper introduces a concept for a peer-to-peer dc microgrid which creates a marketplace for electricity. This network

is enabled by a Power Management Unit that is able to not only provide the conversions necessary to power specific loads but also help establish and control the grid. Combined with an ability to autonomously schedule and price power, such systems can provide reliable electricity to people who could otherwise not access it. This results in people getting access to electricity who are not able to afford power generating sources. It also incentivizes people who can afford power generating sources to invest in more generation as now they are able to sell excess power.

This paper is organized as follows. In section II, the type of the microgrid (whether to have an ac or dc grid) is analyzed. In section III, an overview of the ad-hoc microgrid is given. Section IV presents how the batteries, solar panels and wires are sized. Section V explains the design methodology adopted and section VI presents the architecture considered. Section VII provided an overview of the software and section VIII concludes the paper.

II. TYPE OF MICROGRID

The debate of whether to have a dc or ac grid began more than a century ago. This is usually referred to as the "war of the electric currents" [5]. At that time it was found that an ac grid was a more feasible option mainly because it was difficult to transform dc voltages and thus dc had more loss over large distances. However, after the development of power semiconductor devices and the advancement in power electronics this question has to be reevaluated, especially for off-grid microgrids [6]. In developed regions, changing to dc is not considered feasible owing to the costly ac power grid infrastructure already established. However, dc distribution inside buildings is being proposed as it can result in cost-reduction [9]. For the developing world, the grid infrastructure is either not present or the grid is highly unreliable, so a dc microgrid can be a more feasible option.

The three main consideration for choosing dc or ac microgrids are:

1. Type of power generation
2. Size of the grid
3. Type of loads available

However, for this application safety and stability are also a major concern because the ad-hoc microgrid proposed has to

be low cost, easily configurable and safe for untrained people to interact with.

A. Type of power generation

Conversion losses depend on the type of interface. An ac generating source interfaced with dc distribution results in greater loss as compared to a dc to dc interface [7]. In this network PV panels are being considered as the power generating source which are low-voltage dc sources. The power generated by the PV panels need to be stored in batteries, which are also low voltage dc and are connected to the network. Hence, it is more efficient to interface these dc sources with a Low Voltage Direct Current (LVDC) grid.

B. Size of the grid

The size of the grid (geographical span and power transferred) determines the distribution losses. In the proposed system a peer-to-peer electricity sharing network is created. Power is transferred between two Power Management Units which are placed in neighboring houses. The study of 71 villages, in Indian state of Bihar, conducted by Varshney et al. [8] found that the average distance from each house to its next five closest neighbors is 19.26 m with a standard deviation of 4.76 m. With these small distances and the low power (around 25 W) being distributed, LVDC distribution makes sense.

C. Type of loads available

Most loads, especially those used in off-grid regions such as LED lights and cellphones, are dc and will have less conversion loss if they are powered from a dc grid [9], [10]. Also, most loads (e.g., televisions) that appear to be ac are inherently dc but are commonly available as ac (with ac to dc conversion) because of the existing ac grid infrastructure. Hence, it is much easier to find ac appliances in the market rather than dc. However, as the off-grid market matures the cost and availability of dc appliance is predicted to improve [11].

D. Safety

To transfer electricity over large distances, high voltage is preferred as it reduces the line losses or decreases the cost of the wiring. However, high voltage distribution can be unsafe, especially in a system where interaction with the grid is encouraged.

One of the main causes of death by electric shock is ventricular fibrillation where the heart ceases to pump blood causing a cardiac arrest. Other effects such as muscular contractions, burns and injuries from falling might also occur but ventricular fibrillation has the highest mortality rate and will be considered in this discussion. The severity of the shock depends on magnitude, duration, and frequency of the current. The magnitude of the current is determined by the voltage applied and the impedance of the human body. The impedance varies depending on the persons weight and external conditions. It is lowest for saltwater-wet conditions, i.e. the condition one might have when the person is sweaty.

To determine currents for safe operation, Dalziel theory [12], Koeppens theory [13] and IEC standards are commonly used. As the IEC standards are the most conservative among these we will consider them in this discussion. According to the IEC 60479 standard [14], above 120 mA will cause ventricular fibrillation. Considering the impedance of the human body (940Ω) from Table 3 of IEC60479, voltages below 100 V will not cause ventricular fibrillation. As the impedance of the human body may vary we will consider the more conservative IEC61201 standard [15]. According to Fig. 6 of the standard, 70 V (dc) is the minimum threshold for ventricular fibrillation in saltwater-wet conditions. Hence, ac voltage which is around $120 V_{rms}$ ($220 V_{rms}$ in South Asia), is not touch safe. The duration of the contact is important because there are parts of the heart cycle (recovery from excitation- T) when the ventricles are most vulnerable to cardiac arrest thus if the current flows for a very short time the probability of cardiac arrest decreases [14]. Moreover, ac current is more dangerous than dc current because it causes more frequent and severe muscular contractions. From [15] we can consider 50 V and below as a safe range of operation.

If ac voltage is considered users will not be able to interact with the network and extra safety measure will be needed (such as taller distribution poles, carefully insulated connectors, etc.) which increases the cost of the system. Also, LVDC is preferred as HVDC is not touch safe and requires additional safety measures such as protection devices for basic and fault protection have to be considered which increases the cost and complexity of the system [16].

E. Stability

Dc distribution system offers greater stability as compared to ac distribution [6]. Stability is a major concern in microgrids where each load is a significant portion of the total power of the system. In ac systems voltage and frequency control need to be used for a stable operation. This is regulated with active and reactive power control. In dc systems the control is simpler as only voltage needs to be regulated. Moreover, dc systems enable convenient use of dc storage, which is valuable for maintaining stability. As the proposed microgrid is not preplanned, an ac system will be challenging to control.

Many of the loads of interest in these microgrids are low-voltage dc loads, available (solar) energy sources are inherently low-voltage dc sources, and dc energy storage is a necessary component, making low-voltage dc a more natural native format for the microgrid. Also, for our application safety and stability are a major concern because the ad-hoc microgrid proposed has to be low cost, easily configurable and safe for untrained people to interact with. Hence, dc microgrid is a more viable option from a stability perspective.

III. OVERVIEW OF THE MICORGRID

In order to enable a microgrid with peer-to-peer electricity sharing, a Power Management Unit (PMU) is needed. The PMU provides the power conversions necessary to power loads

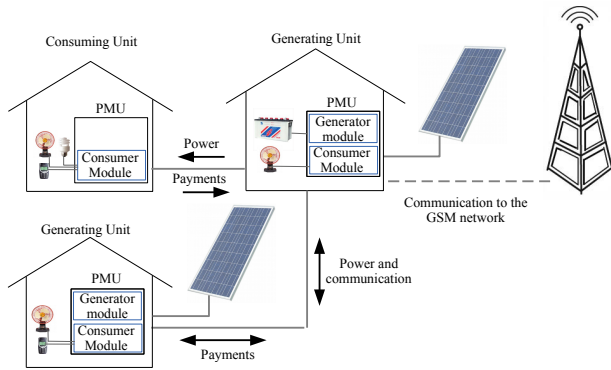

Figure 1: The Power Management Units (PMUs) can connect generating sources, batteries and loads to form an ad-hoc dc microgrid with peer-to-peer electricity sharing.

using power generating sources and storage elements (such as Photovoltaic (PV) panels and batteries) and also routes power between two or more generating sources as shown in Fig. 1.

The dc microgrid has the following features:

- PV panels are used for generation and lead acid batteries are used for storage. These are external to the PMUs. Other generating sources and batteries can also be utilized.
- The PMU as shown in Fig. 1 comprises two modules: a generator module (present only where power sources or and storage are provided) and a consumer module. The generator module takes power from the solar panels and the network and charges a battery. It also maintains the voltage of the distribution network. The consumer module powers the electric devices and appliances in the home.
- The distribution of electricity is at a low voltage and is done by low-cost wires strung between houses connecting two or more PMUs.
- The power transferred between modules is measured at each module and this measurement is used to remunerate the power generator and bill the power consumer.
- Information is transferred between units for scheduling and control of the system.
- Multiple generator modules and consumer modules can be connected to form an ad-hoc microgrid. A scheduling and dispatch algorithm running on the generator module(s) ensures reliable power to the consumers even with the limited resources.

IV. SIZING OF THE SYSTEM

The batteries, solar panels and the wiring need to be sized according to the load. If two or more generating sources are connected, each system can be sized for base load with electricity from the neighboring units used for peak loads.

A. Load

For a single home, the basic loads that need to be powered are lights (5 W, two LED lights at 2.5 W each), cell phone charging (2.5 W) and a fan (15 W). Television (e.g. 15" Phocos, 18 W) or small refrigerators (e.g., Chotukool, 62 W) are possible loads but are not affordable by most people living off-grid due to low unstable incomes. Also these devices require significant power so the operating cost will also be high. These can be additional loads that the PMU supports. However, the basic load that needs to be supported is 25 W.

B. Solar Panel

Consider the case where a consumer uses 25 W and shares 25 W with four neighbours; a total of 125 W is needed. If energy is needed for 6 hrs/day the total energy required (E_{req}) is 750 Wh. This is provided by a solar panel of capacity

$$P_{solar} = E_{req}/(\eta H_{sun}) \quad (1)$$

Where η is the efficiency of the conversions and H_{sun} is hours of sunlight. Considering the irradiance of a location as $5kWh/(m^2day)$, this is equivalent to the site receiving around 5 hours of sunlight per day with $1kW/m^2$ irradiance. As the rating for the solar panel is given for Standard Test Conditions (STC) i.e., for $1kW/m^2$, by using η of 0.7 and 5 hours of sunlight, the solar panel needed should be around 215 W.

All major solar manufacturers (e.g., Yingli, Suntech, Trina Solar and Sungen) produce solar panels of minimum 250 W. Some manufacturers have smaller solar panels for off-grid regions but the cost per watt of smaller solar panels is much higher [17]. At present, in off-grid areas these smaller solar panels of around 40 W are being deployed which are more expensive per watt. Thus, the sharing of electricity has the advantages of economies of scale by aggregating generation.

C. Battery

To supply at least 6 hours of full load the total energy required is 750 Wh per day. Also, in the case of a rainy day (when there is very little irradiance) extra storage would be needed. Using demand management, the full load might not be served and hence the battery capacity requirement will decrease, however, in this discussion we will only consider the simple case.

A deep cycle sealed lead acid battery should not be discharged more than 80% as it can be permanently damaged, however, for a longer life cycle a 50% depth of discharge (DOD) is recommended. Without any extra buffer day (very little irradiance), and with a 50% DOD a battery of 125 Ah capacity is needed, calculated from Equation. 2. However, for a one day buffer and without crossing 70% depth of discharge requirement of the battery, a battery of 180 Ah is required .

$$Capacity = E_{req}(b_{days} + 1)/(\%DV_{bat}) \quad (2)$$

Where b_{days} is the number of buffer days and $\%D$ is the percentage of depth of discharge.

Major battery manufacturers, such as Exide, AMCO, TATA green have their inverter line of batteries with capacities of

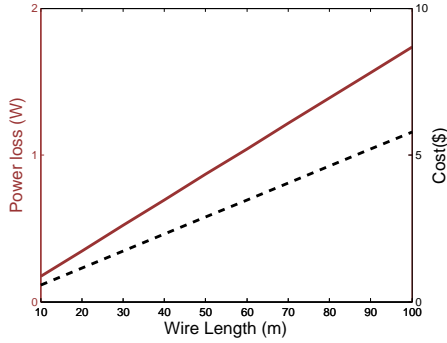

Figure 2: Power loss in distribution and cost of wire with 25 W transferred at 24 V with 14 AWG wire costing \$0.0578 per meter.

150 Ah to 200 Ah. These deep-cycle batteries are well suited for this application.

D. Wiring

Wires are strung between houses for distribution of power. Copper or aluminum insulated wires can be used. Although copper has lower resistivity, aluminum wires are commonly used in South Asia because of their low costs. By considering conduction losses and cost of wires with varying thicknesses, 14 AWG for 25 watt of power was considered a reasonable option, as shown in Fig. 2.

V. DESIGN METHODOLOGY

The Power Management Unit (PMU) can take multiple inputs (such as PV panels and the network connection) and is able to charge/discharge a battery and provide multiple outputs for electronic loads and the network, Fig. 7. The energy access space is a cost constrained environment hence cost is a major design consideration. We want to decrease cost of the PMU as well as that of the overall system. For this we need to decrease the number of voltage conversion steps which require added power conversion stages and decrease the energy storage requirements of the passives. Efficiency is also a major concern as loss translates directly to system cost.

A. Motivation for Modularity

People with the power generating sources are able to share electricity with their neighbors. For every person with access to a power generating source it is assumed there will be 4 or more people consuming power. Thus the power handling capacity of the converter which interfaces with the solar panels should be at least 4 times greater than the power handling capacity of the converter interfacing with consumer device. Hence, the Power Management Unit is being designed to have two modules; a generator module and a consumer module. To power a light, cellphone, and fan around 25 W is needed. This is the estimated load an average consumer is going to have so the consumer module is rated for 25 W while the generator module is rated for 250 W. People who can afford power generating sources are also financially better off and hence can

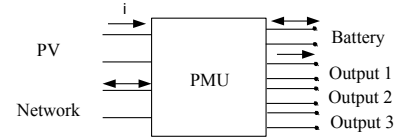
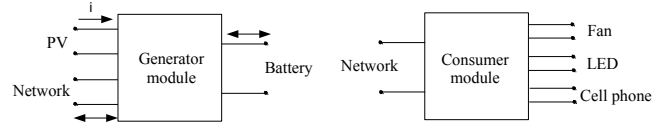

Figure 3: PMU Block Diagram



(a) Generator module

(b) Consumer module

Figure 4: PMU comprises of a generator module and a consumer module

afford the higher cost generator module. The generator module is shown in Fig. 4a and the consumer module is shown in Fig. 4b.

B. Voltages of Operation

To determine the voltages in the microgrid the battery voltage and distribution voltage need to be determined.

For safety reasons, we need to operate below 50 V [15]. The two voltage levels being considered for distribution are 24 V and 48 V. These voltages are commonly used because many devices are available due to the automotive truck industry standard (24 V) and telecom industry standard (48 V) which lowers their cost. Although, operating at 48 V lowers the distribution losses, it increases the cost of the the consumer module which has 12 V and 5 V outputs. The higher conversion cost for 48 V distribution arises from the higher device stresses and passive costs owing to the higher conversion ratio (and especially due to the cost of magnetics). The consumer module is the most price sensitive element in the whole network (Low-cost consumer modules are needed to drive adoption; generation and distribution costs are more readily absorbed by the electricity supplier). Also, 24 V is much safer than 48 V and is being promoted as an indoor dc distribution standard by the EMerge Alliance [18]. Moreover, this voltage is reasonable for the power levels and distribution distances considered in this application (see Fig. 2); and 48 V could be considered for applications where the distances or the power is higher.

For lowering cost of the generator module, a battery voltage of 24 V would be preferred. Typical solar panel voltages vary from 40 V to 25 V and the network voltage has been chosen as 24 V. The lead-acid batteries being considered are nominally 12 V and by putting two in series we can get a battery voltage to 24 V. Also, the cost of batteries (\$/Ah) decreases very sharply up to 33 Ah and then it flattens out [17]. Hence, the cost of having two 90 Ah batteries will be almost same as

having a single 180 Ah battery. However, to increase adoption of the system, compatibility with existing Solar Home Systems (SHS) is needed. Currently, most SHSs in off-grid areas have 12 V batteries, hence a 12 V battery voltage is considered for storage in our system.

An additional feature of HVDC distribution could be added when power is being transferred over large distances (requiring an additional power management unit to interface with this transmission voltage). However, this will involve better protection, insulation and taller electricity poles.

VI. ARCHITECTURE

The Power Management Unit is shown in Fig. 7. The generator module consists of two converters: A charge controller to charge the battery from the solar panel and a bidirectional converter that enables the connection of two or more PMUs to the network. This bidirectional converter is needed because without it, two or more batteries at different generation sites should not have different voltages otherwise they will be shorted, potentially causing high, uncontrolled currents to flow. The bidirectional converter avoids this and also enables electricity sharing. It takes power at the battery voltage and steps it up to the network voltage and also takes extra power on the network and stores it in the battery. The consumer module consists of a dc/dc converter with three outputs. A 12 V, voltage-regulated output (e.g., for fan), a 12 V, current-regulated output (for LED lighting) and 5 V, voltage-regulated output (for cell phone). To power ac devices, a dc to ac module could also be included in the consumer module.

A cascaded architecture or a parallel architecture, as shown in Fig. 5 and Fig. 6 respectively, can be used. The major advantage of using the parallel architecture is that the consumer module can be designed only for the network voltage rather than both the network voltage and battery voltage. In the cascaded system the consumer module will need to operate with an input voltage variation of 10 V to 24 V rather than the narrow range of network variation. Also, the parallel configuration simplifies the control of the power by the generator module as all load converters are connected in the same manner. However, the disadvantage is that the power to the consumer module is always processed by the bidirectional converter hence, depending on the voltages selected, one unit of the PMU (connected generator module and consumer module) may be less efficient in the parallel architecture.

Hence, for simplicity of control, flexibility of design and cost of the consumer module the parallel architecture, as shown in Fig. 6, is chosen.

VII. SOFTWARE OVERVIEW

The microgrid will often be undersupplied because ensuring that all loads are served with certainty under various contingencies is too costly. Therefore, the PMU needs control software that efficiently allocates and dispatches power in consideration of generation and load uncertainty. The software enables the grid to learn about user preferences in terms of power demand, produces a day-ahead schedule that accounts

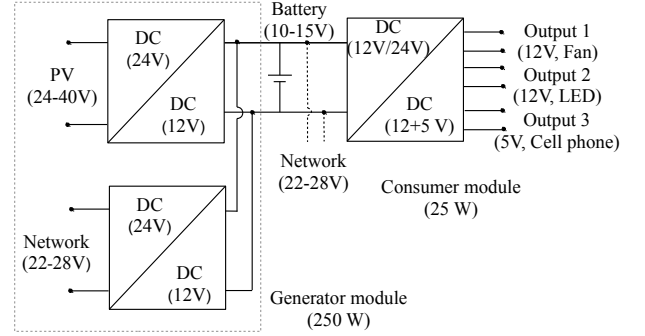

Figure 5: A possible network architecture with cascaded converters and direct battery voltage distribution.

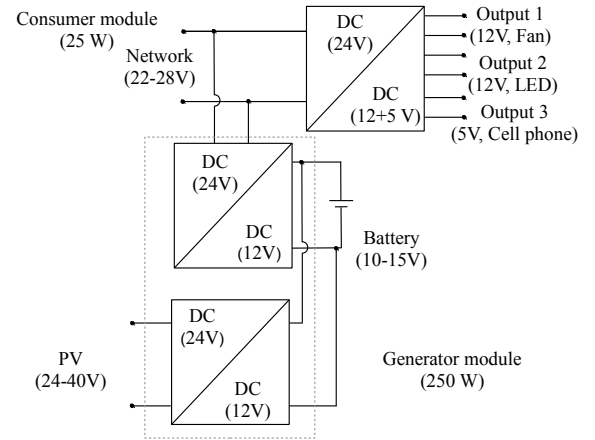

Figure 6: A possible network architecture with parallel converters.

for the stochastic nature of generation and load, and makes dispatch decisions in real-time based on grid state estimates.

A. Day-Ahead Scheduling

Studies indicate that common criteria for grid contingency scheduling (such as the $N - 1$ condition) are too conservative and do not represent the true probability of failure [19]. Instead, the PMU schedules generation and load by explicitly reasoning about the probability of not serving load. This reduces cost and improves user comfort. The day-ahead scheduling algorithm takes as input generation and load forecasts and outputs a schedule with probabilistic guarantees on serving load. It does this by employing a risk-based tatonnement approach that is able to run on a distributed network of low-cost microcontrollers [20].

1) *Load Forecast*: Instead of modeling power demand as an agglomerated load curve, the software uses statistical learning to classify loads into user activities (i.e. charging a cell phone or lighting for dinner) [21] [22]. This approach allows the microgrid to make smart decisions about how to schedule and

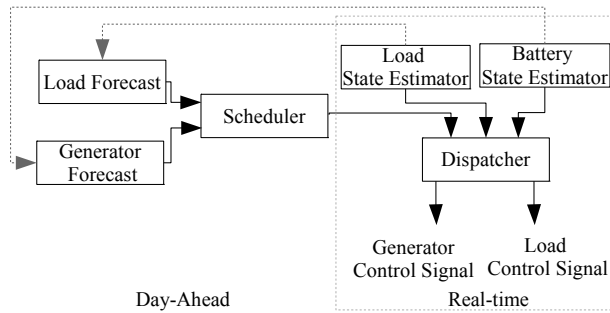

Figure 7: Overview of scheduling and dispatch in the grid

shed load and means that the grid is able to constantly improve the load forecast by updating its model of user preferences.

2) *Generator Forecast*: Historical solar irradiation data is used to predict the solar profile for the day-ahead scheduler. The data includes the probability of various scenarios such as sunny vs. cloudy days to account for uncertainty in generation.

B. Real-time Dispatch

Using state estimates for the batteries' charge states and loads' current power consumption, the dispatch algorithm decides which loads to serve and which batteries provide power. The dispatcher makes decisions to ensure that users receive an agreed upon quality of service and that excess battery capacity is rewarded. Droop control is used to ensure each generator contributes the allocated amount and maintains the grid voltage within limits.

VIII. CONCLUSION

The peer-to-peer electricity sharing network introduced in this paper enables scalable deployment of distributed generation to provide affordable electricity in off-grid areas. Compared to Solar Home Systems (SHSs), the cost per watt of electricity provided by this network is expected to be lower. This is due to demand aggregation, as larger but less expensive (\$/W) Solar panels can be used rather than the smaller (less wattage) individual solar home systems. Also, by managing the aggregated demand, resources can be optimally utilized hence further decreasing the cost of generation and storage. Compared to conventional microgrids, this system is less capital intensive and more scalable because it is built from the bottom up rather than depending on large centralized generation facility. Hence, the proposed system provides a more affordable and scalable electricity access.

ACKNOWLEDGMENT

The authors gratefully acknowledge the support provided for this work by MIT Tata Center for Technology and Design.

REFERENCES

- [1] IEA, *World Energy Outlook 2013*. International Energy Agency, 2013.
- [2] S. Mahapatra and S. Dasappa, "Rural electrification: optimising the choice between decentralised renewable energy sources and grid extension," *Energy for Sustainable Development*, vol. 16, no. 2, pp. 146–154, 2012.
- [3] P. Bardouille, "From gap to opportunity: Business models for scaling up energy access," *International Finance Corporation (IFC)*, 2010.
- [4] D. Schnitzer, D. S. Lounsbury, J. P. Carvallo, R. Deshmukh, J. Apt, and D. M. Kammen, "Microgrids for rural electrification: A critical review of best practices base on seven case studies," *United Nations Foundation*, 2014.
- [5] J. Jonnes, *Empires of light: Edison, Tesla, Westinghouse, and the race to electrify the world*. Random House LLC, 2004.
- [6] J. J. Justo, F. Mwasilu, J. Lee, and J.-W. Jung, "Ac-microgrids versus dc-microgrids with distributed energy resources: A review," *Renewable and Sustainable Energy Reviews*, vol. 24, pp. 387–405, 2013.
- [7] D. Boroyevich, I. Cvetkovic, D. Dong, R. Burgos, F. Wang, and F. Lee, "Future electronic power distribution systems a contemplative view," in *Optimization of Electrical and Electronic Equipment (OPTIM), 2010 12th International Conference on*. IEEE, 2010, pp. 1369–1380.
- [8] K. R. Varshney, G. H. Chen, B. Abelson, K. Nowocin, V. Sakhrani, L. Xu, and B. L. Spatocco, "Targeting villages for rural development using satellite image analysis," *Big Data*, vol. 3, no. 1, pp. 41–53, 2015.
- [9] P. A. Madduri, J. Rosa, S. R. Sanders, E. A. Brewer, and M. Podolsky, "Design and verification of smart and scalable dc microgrids for emerging regions," in *Energy Conversion Congress and Exposition (ECCE), 2013 IEEE*. IEEE, 2013, pp. 73–79.
- [10] B. A. Thomas, I. L. Azevedo, and G. Morgan, "Edison revisited: Should we use dc circuits for lighting in commercial buildings?" in *Energy Policy 45*, 2012, pp. 399–411.
- [11] K. Garbesi, V. Vossos, and H. Shen, "Catalog of dc appliances and power systems," 2011.
- [12] C. F. Dalziel and W. Lee, "Reevaluation of lethal electric currents," *Industry and General Applications, IEEE Transactions on*, no. 5, pp. 467–476, 1968.
- [13] M. Noritake, T. Iino, A. Fukui, K. Hirose, and M. Yamasaki, "A study of the safety of the dc 400 v distribution system," in *Telecommunications Energy Conference, 2009. INTELEC 2009. 31st International*. IEEE, 2009, pp. 1–6.
- [14] IEC, "Effects of current on human beings and livestock. part 1: General aspects," *IEC 60479-1*, 2005.
- [15] —, "Use of conventional touch voltage limits - application guide," *IEC 61201*, 2007.
- [16] R. M. Cuzner and G. Venkataramanan, "The status of dc micro-grid protection," in *Industry Applications Society Annual Meeting, 2008. IAS'08. IEEE*. IEEE, 2008, pp. 1–8.
- [17] A. Campanella, "An analysis of the viability and competitiveness of dc microgrids in northern india," Master's thesis, Massachusetts Institute of Technology, 2013.
- [18] "Public overview of the emerge alliance occupied space standard version 1.1," *EMerge Alliance*, 2012.
- [19] R. Moreno, D. Pudjianto, and G. Strbac, "Future transmission network operation and design standards to support a low carbon electricity system," in *Power and Energy Society General Meeting, 2010 IEEE*, July 2010, pp. 1–5.
- [20] D. Strawser, W. Inam, and B. Williams, "A market for reliability for electricity scheduling in developing world microgrids (extended abstract)," in *Proceedings of the 2015 International Conference on Autonomous Agents and Multi-agent Systems*, ser. AAMAS '15, IEEE. International Foundation for Autonomous Agents and Multiagent Systems, 2015.
- [21] R. Subbiah, K. Lum, A. Marathe, and M. Marathe, "Activity based energy demand modeling for residential buildings," in *Innovative Smart Grid Technologies (ISGT), 2013 IEEE PES*, Feb 2013, pp. 1–6.
- [22] N. C. Truong, L. Tran-Thanh, E. Costanza, and D. S. Ramchurn, "Activity prediction for agent-based home energy management," in *Proceedings of Fourth International Workshop on Agent Technology for Energy Systems (ATES 2013)*, 2013.