

Integrated Circuits Based on Bilayer MoS₂ Transistors

H. Wang^{1,*†}, L. Yu^{1,†}, Y.-H. Lee^{1,3}, Y. Shi¹, A. Hsu¹, M. Chin², L.-J. Li³, M. Dubey², J. Kong¹, T. Palacios^{1,*}

¹Department of Electrical Engineering and Computer Science, Massachusetts Institute of Technology, 77 Massachusetts Avenue, Cambridge MA 02139, USA. Tel: +1 (617) 324-2395.

²United States Army Research Laboratory, 2800 Powder Mill Road, Adelphi, MD 20783-1197, USA.

³Institute of Atomic and Molecular Sciences, Academia Sinica, Taipei, 11529, Taiwan.

*Corresponding author E-mail: hanw@mit.edu, tpalacios@mit.edu.

†H. W. and L. Y. contributed equally to this work.

Abstract

Two-dimensional (2D) materials, such as molybdenum disulfide (MoS₂), have been shown to exhibit excellent electrical and optical properties. The semiconducting nature of MoS₂ allows it to overcome the shortcomings of zero-bandgap graphene, while still sharing many of graphene's advantages for electronic and optoelectronic applications. Discrete electronic and optoelectronic components, such as field-effect transistors, sensors and photodetectors made from few-layer MoS₂ show promising performance as potential substitute of Si in conventional electronics and of organic and amorphous Si semiconductors in ubiquitous systems and display applications. An important next step is the fabrication of fully integrated multi-stage circuits and logic building blocks on MoS₂ to demonstrate its capability for complex digital logic and high-frequency ac applications. This paper demonstrates an inverter, a NAND gate, a static random access memory, and a five-stage ring oscillator based on a direct-coupled transistor logic technology. The circuits comprise between two to twelve transistors seamlessly integrated side-by-side on a single sheet of bilayer MoS₂. Both enhancement-mode and depletion-mode transistors were fabricated thanks to the use of gate metals with different work functions.

Keywords: molybdenum disulfide (MoS₂), transition metal dichalcogenides (TMD), Two-dimensional (2D) electronics, integrated circuits, ring oscillator.

Two-dimensional (2D) materials, such as molybdenum disulfide (MoS_2)¹ and other members of the transition metal dichalcogenides family, represents the ultimate scaling of material dimension in the vertical direction. Nano-electronic devices built on 2D materials offer many benefits for further miniaturization beyond Moore's Law^{2,3} and as a high-mobility option in the emerging field of large-area and low-cost electronics that is currently dominated by low-mobility amorphous silicon⁴ and organic semiconductors^{5,6}. MoS_2 , a 2D semiconductor material, is also attractive as a potential complement to graphene^{7,8,9} for constructing digital circuits on flexible and transparent substrates, while its 1.8 eV bandgap^{10,11} is advantageous over silicon for suppressing the source-to-drain tunneling at the scaling limit of transistors¹². Recently, various basic electronic components have been demonstrated based on few-layer MoS_2 , such as field-effect transistors (FETs)^{13,14,15}, sensors¹⁶ and phototransistors¹⁷. However, until now, only primitive circuits involving one or two discrete MoS_2 transistors connected through external wiring have been reported¹⁸. These devices also have mismatched input and output logic levels, making them unsuitable for cascading multiple logic stages. This paper addresses the next challenge in the development of 2D nanoelectronics and optoelectronics on MoS_2 , that is the construction of fully integrated multi-stage logic circuits based on this material to demonstrate its capability for complex digital logic. These circuits were fabricated entirely on the same chip for the first time thanks to the seamless integration of both depletion-mode (D-mode) and enhancement-mode (E-mode) MoS_2 transistors. The transistors show multiple state-of-the-art characteristics, such as current saturation, high on/off ratio ($>10^7$), and record on-state current density ($>23 \mu\text{A}/\mu\text{m}$). This demonstration of integrated logic gates, memory elements and a ring oscillator operating at 1.6 MHz represents an important step towards developing 2D electronics for both conventional and ubiquitous applications, offering materials that can combine silicon-like performance with the mechanical flexibility and integration versatility of organic semiconductors.

Molybdenum disulfide (MoS_2) is a layered semiconductor from the transition metal dichalcogenides material family (TMD), MX_2 (M=Mo, W; X=S, Se, Te)^{10,11,19,20}. A single molecular layer of MoS_2 consists of a layer of Mo atoms sandwiched between two layers of sulfur atoms by covalent bonds¹⁰. The strong intra-layer covalent bonds confer MoS_2 crystals excellent mechanical strength, thermal stability up to 1090 °C in inert environment²¹, and a surface free of dangling bonds. On the other hand, the weak inter-layer Van der Waal's force allows single- or few-layer MoS_2 thin films to be created through micro-mechanical cleavage technique²² and through anisotropic 2D

growth by chemical vapor deposition^{23,24}. This unique property of MoS₂, and 2D materials in general, enables the creation of atomically smooth material sheets and the precise control on its number of molecular layers. Field-effect transistors (FETs) built on the ultra-thin few-layer 2D crystals, hence, are effectively the optimal form of ultra-thin body FETs²⁵, a transistor structure ideal for suppressing the short-channel effects at its scaling limit. This benefit of 2D FETs has been demonstrated in ref. ¹⁴, which shows a high on/off current ratio of 10⁸ in a single-layer MoS₂ FET.

The planar nature and mechanical flexibility of 2D materials also make them excellent candidates for fabricating light-weight and rollable or foldable electronic systems on common commodities like paper, plastics and textiles; as well as for constructing low-cost driving circuits for flat-panel display applications²⁶. The incumbent technology for such applications is based on amorphous Si and polycrystalline Si, with organic semiconductors being the other potential option. Thin film transistors based on amorphous Si, for example, often have mobility below 1 cm² V⁻¹ s⁻¹, the on-off ratio in excess of 10⁶, and the device switches from on to off within about 5–8 V, making it barely fit within the requirements of display applications⁴. The organic semiconductors offer ease of fabrication, but exhibit similar or even lower mobility than amorphous Si due to its intrinsically disordered nature and quantum-mechanical-tunneling based transport²⁷. In contrast, the covalently-bonded, highly-ordered crystalline 2D materials have carrier mobility that is orders of magnitude higher than in amorphous Si and organic semiconductors. 2D materials are thus promising for improving the performance and enable new functionality of ubiquitous electronics and display technology, such as flexible radio-frequency identification tags and enhanced integration of drivers and logic circuits into display backplanes.

In this letter, we address the next key challenge in the development of 2D nanoelectronics by demonstrating the first fully integrated multi-stage circuits entirely assembled on few-layer MoS₂. These circuits are based on the development of a direct-coupled FET logic (DCFL)²⁸ in this material system, for which both enhancement-mode and depletion-mode devices with excellent pinch-off and current saturation are necessary. All the circuits were fabricated on bilayer MoS₂ obtained from micro-mechanical cleavage. Bilayer MoS₂ offers an excellent trade-off between the off-state and on-state current levels (see Supplementary Information). The number of MoS₂ layers can be confirmed by atomic force microscopy (AFM) (Fig. 1A) based on its thickness and by Raman spectroscopy based on the peak spacing between the E_{2g} mode and the A_{1g} mode²⁹, respectively (Fig. 1B and Supplementary

Information Fig. S1). The lateral size of the exfoliated bilayer MoS₂ thin films, which are 13 Å thick, can reach up to 40 μm (Inset of Fig. 1A).

The direct-coupled FET logic (DCFL) technology is a popular architecture for constructing high-speed circuit with low power dissipation, where an excellent trade-off between speed and power loss may be achieved^{30,31} and is suitable for application in low-power flexible electronics. The DCFL circuits used in this letter integrates both negative (D-mode) and positive (E-mode) threshold voltage transistors on the same chip (Fig. 2A and 2B). This can be achieved through engineering the gate metal work functions of the MoS₂ FETs (see Supplementary Information). Fig. 2C and 2D shows the device characteristics of two MoS₂ FETs with Al ($w_M = 4.08$ eV) and Pd ($w_M = 5.12$ - 5.60 eV)³² gates, respectively, fabricated side-by-side on the same bilayer MoS₂ thin film (see Supplementary Information for fabrication). The difference in the work functions of these two metals effectively shifts the threshold voltages of the MoS₂ FET characteristics by about 0.76 V to form a D/E-FET pair (Fig. 2C and 2D). The shift in the threshold voltage is lower than the metal work function difference in vacuum (~1.04 eV) (see Supplementary Information).

Both the D-mode and E-mode FETs have a high on/off current ratio in excess of 10^7 (Fig. 2D), which is very close to that in single-layer MoS₂ FETs¹⁴. On the other hand, at the on-state, these devices based on bilayer MoS₂ have much higher on-state current density (exceeding 23 μA/μm at $V_{ds}=1.0$ V and $V_{tg}=2.0$ V for the depletion mode FET, Fig. 2C) than that reported for single-layer MoS₂ FETs^{14,18}. The corresponding maximum transconductance of the bilayer FETs exceeds 12 μS/μm at $V_{ds}=1.0$ V. These bilayer MoS₂ FETs can hence offer superior on-state performance than single-layer devices, with only a small degradation in terms of on/off current ratio. The high-field transport of both FETs shows saturation behavior (Fig. 3A), a critical feature for both logic and analog circuits, for the first time in top-gate MoS₂ FETs. The excellent match between the on-set of saturation and the gate overdrive (i.e. $V_{sat}=V_{tg}-V_t$, where V_{sat} is the saturation voltage and V_t is the threshold voltage of the FETs) indicates that the current saturation is due to the classic channel pinch-off mechanism, as is typical for long channel MOSFETs³³. The field-effect mobility at $V_{ds}=1$ V is extracted to be 10-15 cm² V⁻¹ s⁻¹ before depositing the hafnium oxide (HfO₂). After the MoS₂ thin film was passivated by a 20-nm-thick HfO₂ layer, a conservative estimate based on back-gated characteristics shows a field effect mobility exceeding 300 cm² V⁻¹ s⁻¹ (see Supplementary Information).

Using the technology described above, we built four different integrated logic circuits entirely assembled on bilayer MoS₂: a logic inverter, a NAND gate, a static random access memory (SRAM) cell, and a 5-stage ring oscillator, all constructed with DCFL technology²⁸. For each of the four logic circuits, all active and passive elements are integrated on the same piece of bilayer MoS₂. It is found that a supply voltage of $V_{dd}=2$ V is suitable for operating the fabricated circuits. Hence, in this letter, a voltage level close to 2 V represents the logic state 1 while a voltage level close to 0 V represents the logic state 0.

An inverter circuit is a basic logic element that outputs a voltage representing the opposite logic-level to its input. Our inverter was constructed from an enhancement-mode MoS₂ transistor, and a depletion-mode resistor that was formed by connecting the gate of a depletion-mode transistor directly to its source electrode (Fig. 3B inset and Fig. 5A). The quality of a logic inverter is often evaluated using its voltage transfer curve (Fig. 3B), which is a plot of input vs. output voltage. When the input voltage is $V_{in}=2$ V (logic state 1), the E-mode MoS₂ FET is much more conductive than the depletion-mode FET, setting the output voltage to below 0.2 V (logic state 0). When V_{in} is 0 V (logic state 0), the MoS₂ FET is non-conducting and the output is close to 2 V (logic state 1). The slope of the transition region in the middle provides a measure of the gain - or the quality of switching. In the circuit of Fig. 3B, a voltage gain close to 5 is achieved. Fig. 3B also shows the mirror reflection of the V_{in} - V_{out} characteristics, which highlights the robustness of the inverter towards noise for multi-stage operations. When multiple inverter stages are cascaded together, the output signal from the previous stage becomes the input signal to the next stage. Hence, the shaded area (NM_L and NM_H) represents the noise margin that can be tolerated by the inverter for multi-stage operations, which is particularly important for the demonstration of the ring oscillator.

The schematic design and the optical micrograph of an NAND gate circuit fabricated on a sheet of bilayer MoS₂ are shown in Fig 4A. The output of the circuit is close to 2 V (logic state 1) when either or both of the inputs are at logic state 0 ($V_{in} < 0.5$ V). Under this state, at least one of the MoS₂ FETs is non-conducting and the output voltage is clamped to the supply voltage V_{dd} . The output is at logic state 0 only when both inputs are at logic state 1, so that both MoS₂ FETs are conducting. In Fig. 4C, the output voltage is measured as a function of time while the two input voltage states vary across all four possible logic combinations (0,0), (0,1), (1,0), and (1,1). This data demonstrates the stable NAND gate functions of this two-transistor bilayer MoS₂ circuit. A NAND gate is one of the two basic logic gates (the other being NOR gate) with universal functionality. Any other type of logic gates (AND, OR, NOR,

XOR, etc.) can then be constructed with a combination of NAND gates. Hence, this first demonstration of a NAND gate shows that it is possible to fabricate any kind of digital integrated circuit with MoS₂ thin film layers.

A flip-flop memory element (SRAM) has also been constructed from a pair of cross-coupled inverters (Fig. 4A). This storage cell has two stable states at the output, which are denoted as 0 and 1. The flip-flop cell can be set to logic state 1 (or 0) by applying a low (or high) voltage to the input. To verify the functionality of this flip-flop cell, a voltage source is applied to the input to set V_{in} to 2 V at time $T=0$ s. This drives V_{out} into logic state 0 (Fig. 4B). Then at $T=20$ s, the switch at V_{in} is opened and the output of the SRAM cell V_{out} remains at logic state 0. At time $T=60$ s, we apply $V_{in}=0$ V at the input to write a logic state 1 into V_{out} . As the switch is opened again at $T=80$ s, the output of the SRAM cell remains in the logic state 1. This data demonstrates that the flip-flop SRAM circuit fabricated on the bilayer MoS₂ thin film indeed functions as a stable memory cell.

Finally, a 5-stage ring oscillator was constructed to assess the high frequency switching capability of MoS₂ and for evaluating the material's ultimate compatibility with conventional circuit architecture^{28,34,35,36} (Fig. 5A). The ring oscillator, which integrates 12 bilayer MoS₂ FETs together, was realized by cascading five inverter stages in a close loop chain (Fig. 5B). An extra inverter stage was used to synthesize the output signal by isolating the oscillator operation from the measurement setup to prevent the interference between them. The output of the circuit was connected to either an oscilloscope or a spectrum analyzer for evaluation. The voltage transfer curve of the test inverter circuit fabricated side-by-side on the same piece of bilayer MoS₂ thin film (Fig. 3B and Fig. 5A) as the ring oscillator, shows that the gain in each inverter stage is close to 5. For robust ring oscillator performance, it is imperative to have stable operations in all five inverter stages throughout the oscillation cycles, and its tolerance towards noise can be determined from the noise margins for both low and high logic levels, i.e. the shaded regions in Fig. 3B. The positive feedback loop in the ring oscillator results in a statically unstable system, and the voltage at the output of each inverter stage oscillates as a function of time (Fig. 5C). At $V_{dd}=2$ V, the fundamental oscillation frequency is at 1.6 MHz, corresponding to a propagation delay of $\tau_{pd} = 1/(2nf) = 62.5$ ns per stage, where n is the number of stages and f is the fundamental oscillation frequency. The frequency performance of this ring oscillator, while operating at a much lower V_{dd} , is at least an order of magnitude better than the fastest integrated organic semiconductor ring oscillators³⁵. It also rivals the speed of ring oscillators constructed from the printed ribbons of

single-crystalline silicon reported in the literature³⁷. The output voltage swing measured by the oscilloscope (input impedance 1 M Ω) is about 1.2 V.

The output signal of the ring oscillator can also be measured in terms of its frequency power spectrum. Fig. 5D shows the spectrum of the output signal from the ring oscillator as a function of the drain bias voltage V_{dd} (Fig. 5D). The resonance frequency is at 0.52 MHz for $V_{dd}=1.15$ V. The corresponding fundamental resonance frequency reaches 1.6 MHz as V_{dd} increases to 2 V. The improvement in frequency performance with increasing V_{dd} can be attributed to the enhancement in the current driving capability of the ring oscillator due to the rise in the drain current I_{ds} in each individual MoS₂ FET with increasing drain and gate voltages. The fundamental frequency of oscillation is currently limited by the parasitic capacitances in various parts of the circuit rather than the intrinsic performance of the MoS₂ devices (see Supplementary Information). The signal peaks measured by the spectrum analyzer increases from -65 dBm to -46 dBm as V_{dd} raises from 1.15 V to 2V. This is again a result of the I_{ds} dependence on V_{dd} .

To summarize, the realization of fully integrated multi-stage logic circuits based on few-layer MoS₂ DCFL represents the first demonstration of integrated multi-stage systems on any 2D materials, including graphene. It is an important step towards realizing 2D nanoelectronics for high performance low-power applications. Further optimization is underway to increase operating speed, and towards realizing complementary logic circuits to decrease the power dissipation. With the rapid progress in large-scale growth of MoS₂ by chemical vapor deposition^{23,24}, these 2D crystals are extremely promising new materials for both conventional and ubiquitous electronics.

Acknowledgement

The authors are grateful to D. Antoniadis and L. Wei for discussions. The authors acknowledge financial support from the Office of Naval Research (ONR) Young Investigator Program, the Microelectronics Advanced Research Corporation Focus Center for Materials, Structure and Device (MARCO MSD), National Science Foundation (NSF DMR 0845358) and the Army Research Laboratory. This research has made use of the MIT MTL and Harvard CNS facilities.

Additional information

The authors declare no competing financial interests.

References

1. Helveg, S. *et al.* Atomic-scale structure of single-layer MoS₂ nanoclusters. *Phys. Rev. Lett.* **84**, 951–954 (2000).
2. Liu L., Kumar, S. B., Ouyang Y. & Guo J. Performance limits of monolayer transition metal dichalcogenide transistors. *IEEE Transactions on Electron Devices* **58**, 3042–3047 (2011).
3. Yoon, Y., Ganapathi, K. & Salahuddin, S. How good can monolayer MoS₂ transistors be? *Nano Lett.* **11**, 3768–3773 (2011).
4. Street, R. A. Thin-Film Transistors. *Advanced Materials* **21**, 2007–2022 (2009).
5. Forrest, S. R. The path to ubiquitous and low-cost organic electronic appliances on plastic. *Nature* **428**, 911–918 (2004).
6. Dimitrakopoulos, C. D. & Mascaro, D. J. Organic thin-film transistors: A review of recent advances. *IBM Journal of Research and Development* **45**, 11–27 (2001).
7. Wang, H., Nezych, D., Kong, J. & Palacios, T. Graphene Frequency Multipliers. *IEEE Electron Device Letters* **30**, 547–549 (2009).
8. Wang, H., Hsu, A., Wu, J., Kong, J. & Palacios, T. Graphene-Based Ambipolar RF Mixers. *IEEE Electron Device Letters* **31**, 906–908 (2010).
9. Lin, Y.-M. *et al.* Wafer-Scale Graphene Integrated Circuit. *Science* **332**, 1294–1297 (2011).
10. Mak, K. F., Lee, C., Hone, J., Shan, J. & Heinz, T. F. Atomically Thin MoS₂: A New Direct-Gap Semiconductor. *Phys. Rev. Lett.* **105**, 136805 (2010).
11. Splendiani, A. *et al.* Emerging Photoluminescence in Monolayer MoS₂. *Nano Lett.* **10**, 1271–1275 (2010).
12. Wang, J. & Lundstrom, M. Does source-to-drain tunneling limit the ultimate scaling of MOSFETs? *IEEE Tech. Dig. IEDM* 707–710 (2002).
13. Ayari, A., Cobas, E., Ogundadegbe, O. & Fuhrer, M. S. Realization and electrical characterization of ultrathin crystals of layered transition-metal dichalcogenides. *Journal of Applied Physics*, **101**, 014507 (2007).
14. Radisavljevic, B., Radenovic, A., Brivio, J., Giacometti, V. & Kis, A. Single-layer MoS₂ transistors. *Nature Nanotechnology* **6**, 147–150 (2011).
15. Liu, H. & Ye, P. D. MoS₂ dual-gate MOSFET with atomic-layer-deposited as top-gate dielectric. *IEEE Electron Device Letters* **33**, 546–548 (2012).
16. Li, H. *et al.* Fabrication of single- and multilayer MoS₂ film-based field-effect transistors for sensing NO at room temperature. *Small* **8**, 63–67 (2012).
17. Yin, Z. *et al.* Single-layer MoS₂ phototransistors. *ACS Nano* **6**, 74–80 (2012).
18. Radisavljevic, B., Whitwick, M. B. & Kis, A. Integrated circuits and logic operations based on single-layer MoS₂. *ACS Nano* **5**, 9934–9938 (2011).
19. Coehoorn, R. *et al.* Electronic structure of MoSe₂, MoS₂, and WSe₂. I. Band-structure calculations and photoelectron spectroscopy. *Phys. Rev. B* **35**, 6195–6202 (1987).
20. Tenne, R., Margulis, L., Genut, M. & Hodes, G. Polyhedral and cylindrical structures of tungsten disulphide. *Nature* **360**, 444–446 (1992).
21. Spalvins, T. A review of recent advances in solid film lubrication. *Journal of Vacuum Science Technology A: Vacuum, Surfaces, and Films*, **5**, 212–219 (1987).
22. Novoselov, K. S. *et al.* Two-dimensional atomic crystals. *Proc. Natl. Acad. Sci. USA* **102**, 10451–10453 (2005).
23. Lee, Y.-H., *et al.* Synthesis of Large-Area MoS₂ Atomic Layers with Chemical Vapor Deposition. *Advanced Materials* **24**, 17, 2320–2325 (2012).
24. Zhan, Y., Liu, Z., Najmaei, S., Ajayan, P. M. & Lou, J. Large-area vapor-phase growth and characterization of MoS₂ atomic layers on a SiO₂ substrate. *Small* **8**, 966–971 (2012).
25. Choi, Y.-K. *et al.* Ultra-thin body SOI MOSFET for deep-sub-tenth micron era. *Electron Devices Meeting, 1999. IEDM Technical Digest. International* 919–921 (1999).doi:10.1109/IEDM.1999.824298
26. Bae, S. *et al.* Roll-to-roll production of 30-inch graphene films for transparent electrodes. *Nature Nanotechnology* **5**, 574–578 (2010).
27. Karl, N. Charge carrier transport in organic semiconductors. *Synthetic Metals* **133–134**, 649–657 (2003).
28. Ayers, J. E. *Digital integrated circuits: analysis and design*. (CRC Press: 2004).
29. Lee, C. *et al.* Anomalous lattice vibrations of single- and few-layer MoS₂. *ACS Nano* **4**, 2695–2700 (2010).
30. Kuroda, S. *et al.* 0.25 μm gate length N-InGaP/InGaAs/GaAs HEMT DCFL circuit with lower power dissipation than high-speed Si CMOS circuits. *International Electron Devices Meeting (IEDM) Technical Digest*, 323–326 (1992).
31. Chen, W.-K. *Analog Circuits and Devices*. (CRC Press: 2003).

32. Michaelson, H. B. The work function of the elements and its periodicity. *Journal of Applied Physics* **48**, 4729–4733 (1977).
33. Tsividis, Y. & McAndrew, C. *Operation and modeling of the MOS transistor*. (Oxford University Press, USA: 2010).
34. Sun, D. *et al.* Flexible high-performance carbon nanotube integrated circuits. *Nature Nanotechnology* **6**, 156–161 (2011).
35. Fix, W., Ullmann, A., Ficker, J. & Clemens, W. Fast polymer integrated circuits. *Applied Physics Letters* **81**, 1735–1737 (2002).
36. Chen, Z. *et al.* An integrated logic circuit assembled on a single carbon nanotube. *Science* **311**, 1735 (2006).
37. Kim, D.-H. *et al.* Complementary Logic Gates and Ring Oscillators on Plastic Substrates by Use of Printed Ribbons of Single-Crystalline Silicon. *IEEE Electron Device Letters* **29**, 73–76 (2008).
38. Gu, D., Dey, S. K. & Majhi, P. Effective work function of Pt, Pd, and Re on atomic layer deposited HfO₂. *Applied Physics Letters* **89**, 082907 (2006).

Figures

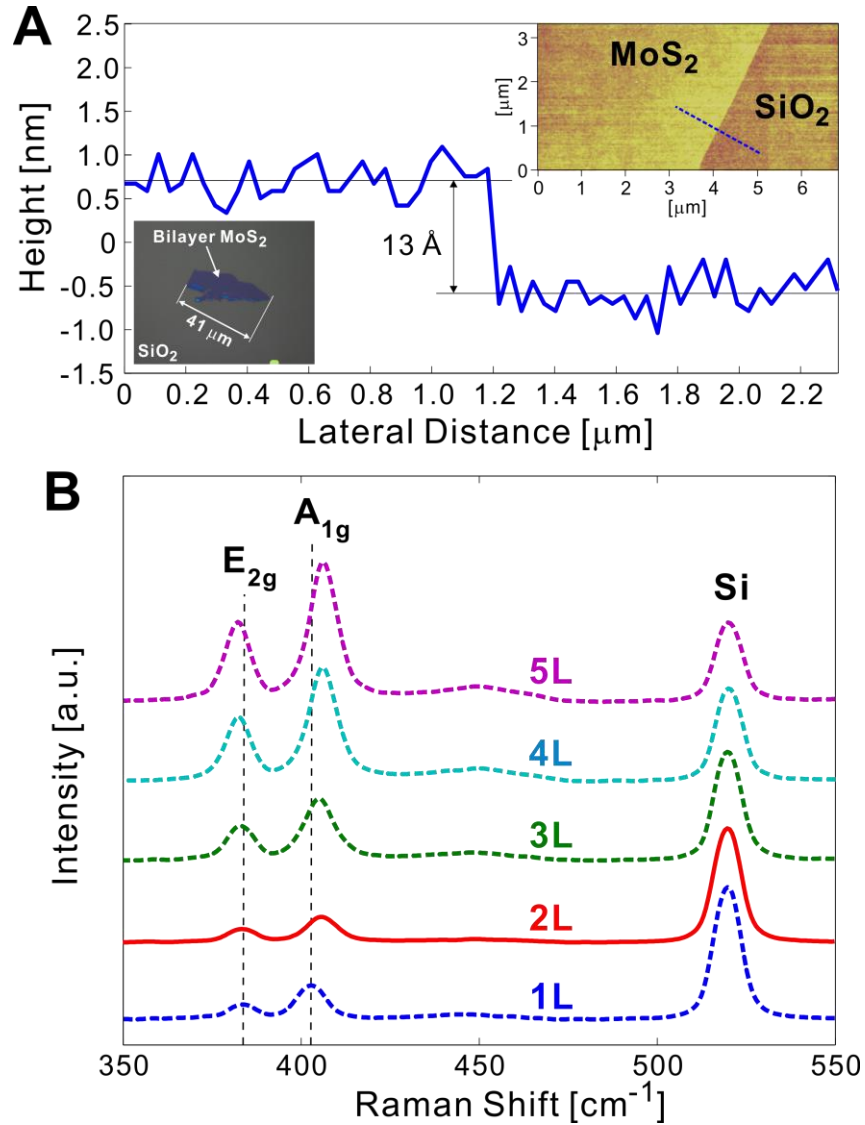

Fig. 1. Optical micrograph, AFM and Raman spectroscopy of bilayer MoS₂. **(A)** Optical micrograph and AFM data of a bilayer MoS₂ thin film. The flake is 13 Å thick, which is equal to twice the thickness of single-layer MoS₂, confirming the flake being bilayer. **(B)** The number of layers in the MoS₂ thin film can also be confirmed from its Raman spectroscopy based on the peak spacing between the E_{2g} mode and the A_{1g} mode²⁹. The red-shift of E_{2g} peak and blue-shift of A_{1g} peak lead to increasing peak spacing between E_{2g} and A_{1g} modes as the number of layers in the MoS₂ thin film increases.

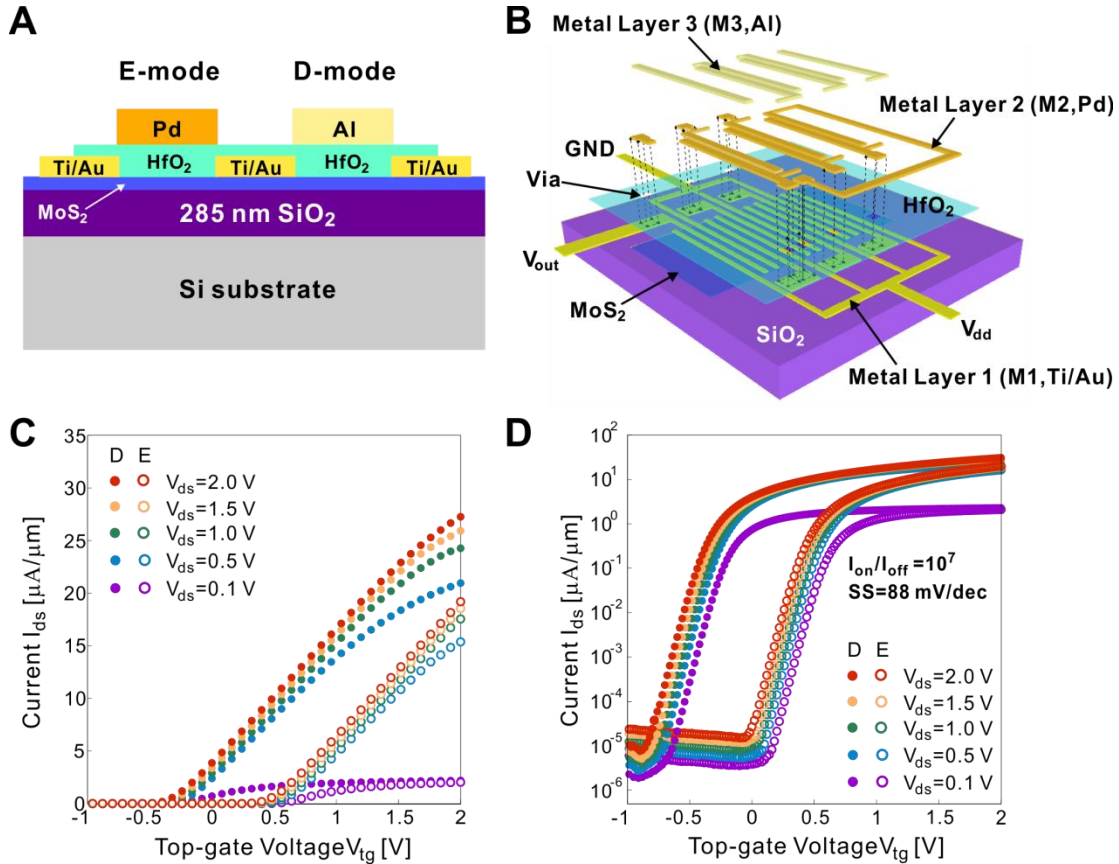

Fig. 2. (A) Schematic representation of an E-mode and a D-mode device. **(B)** Schematic illustration of an integrated 5-stage ring oscillator circuit on MoS₂ thin films, which is constructed by integrating 12 MoS₂ FETs. Three distinct metal layers of the MoS₂ IC are represented by M1, M2, and M3. M1 is directly in contact with the bilayer MoS₂ thin film while M2 and M3 are the Pd and Al gate layers, respectively. Via holes are etched through the HfO₂ dielectric layer to allow connections from M2 and M3 to M1. The fabricated ring oscillator circuit corresponding to the design above is shown in Fig. 5. The general aspects of the fabrication process apply to all the devices and logic circuits presented in this letter. **(C)** The transfer characteristics of depletion (D) mode and enhancement (E) mode bilayer MoS₂ FETs. The depletion mode FET has Al as the gate metal while the enhancement FET has Pd as the gate metal. The on-state current and transconductance of a device are its key dc performance metrics, critical for circuit application. In these bilayer MoS₂ FETs, the on-state current density exceeds 23 $\mu\text{A}/\mu\text{m}$ at $V_{ds}=1$ V and the transconductance is above 12 $\mu\text{S}/\mu\text{m}$, both being the highest values reported for MoS₂ FETs so far. The difference between the work functions of Al and Pd (~ 1.04 V in vacuum) gates results in a 0.76 V shift in the threshold voltage. The discrepancy between the work function difference in vacuum and in HfO₂ can be attributed to the dipoles at the metal/HfO₂ interface, resulting from charge transfer across this boundary³⁸. **(D)** The transfer characteristics in logarithmic scale of depletion (D) mode and enhancement (E) mode bilayer MoS₂ FETs. The I_{on}/I_{off} ratio exceeds 10^7 for V_{ds} above 0.5 V, and is about 10^6 at $V_{ds}=0.1$ V. The sub-threshold slope (SS) is 88 mV/dec. Device dimension: $L_g=1$ μm and $L_{ds}=1$ μm . The substrate is grounded.

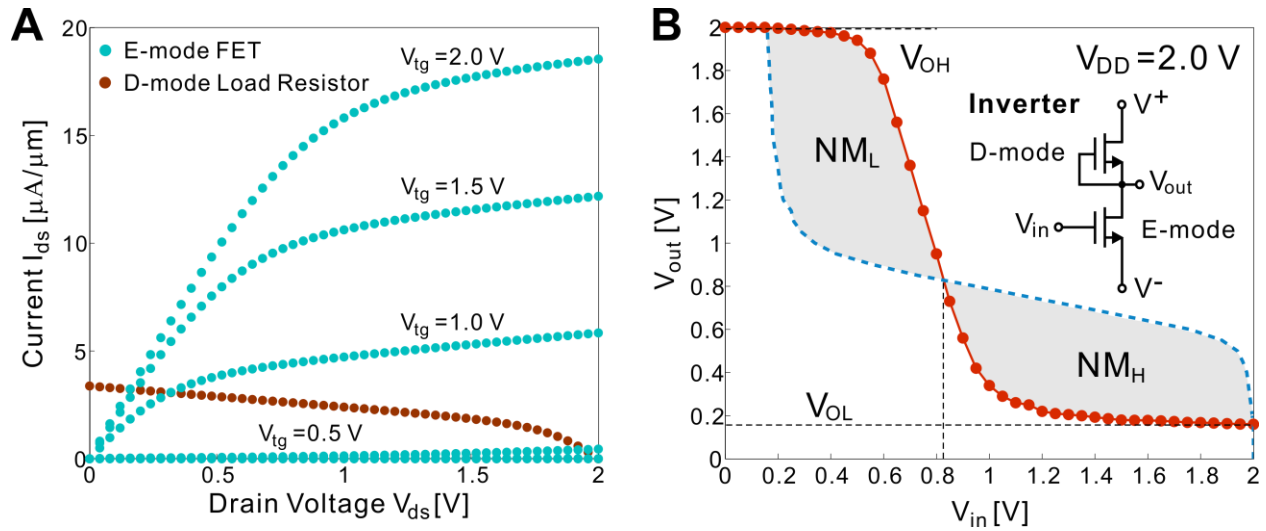

Fig. 3. Demonstration of an integrated logic inverter on bilayer MoS₂. **(A)** Output characteristics (I_{ds} - V_{ds}) of the E-mode FET and D-mode load for the inverter shown in Fig. 5A. $L_g=1\ \mu\text{m}$ and $L_{ds}=1\ \mu\text{m}$. For the E-mode FET, in the linear regime at small source-drain voltages, the current is proportional to V_{ds} , indicating that the source and drain electrodes made of Ti/Au metal stack forms ohmic contact with MoS₂. The current saturates at higher drain bias ($V_{ds}>V_g-V_t$) due to the formation of depletion region on the drain side of the gate, as is typical of long channel MOSFETs. **(B)** Output voltage as a function of the input voltage, and its mirror reflection, for a bilayer MoS₂ logic inverter. The shaded area indicates its noise margins (NM_L and NM_H) for logic operation. The gain of the inverter is close to 5. (Inset) Schematic of the electronic circuit for a logic inverter.

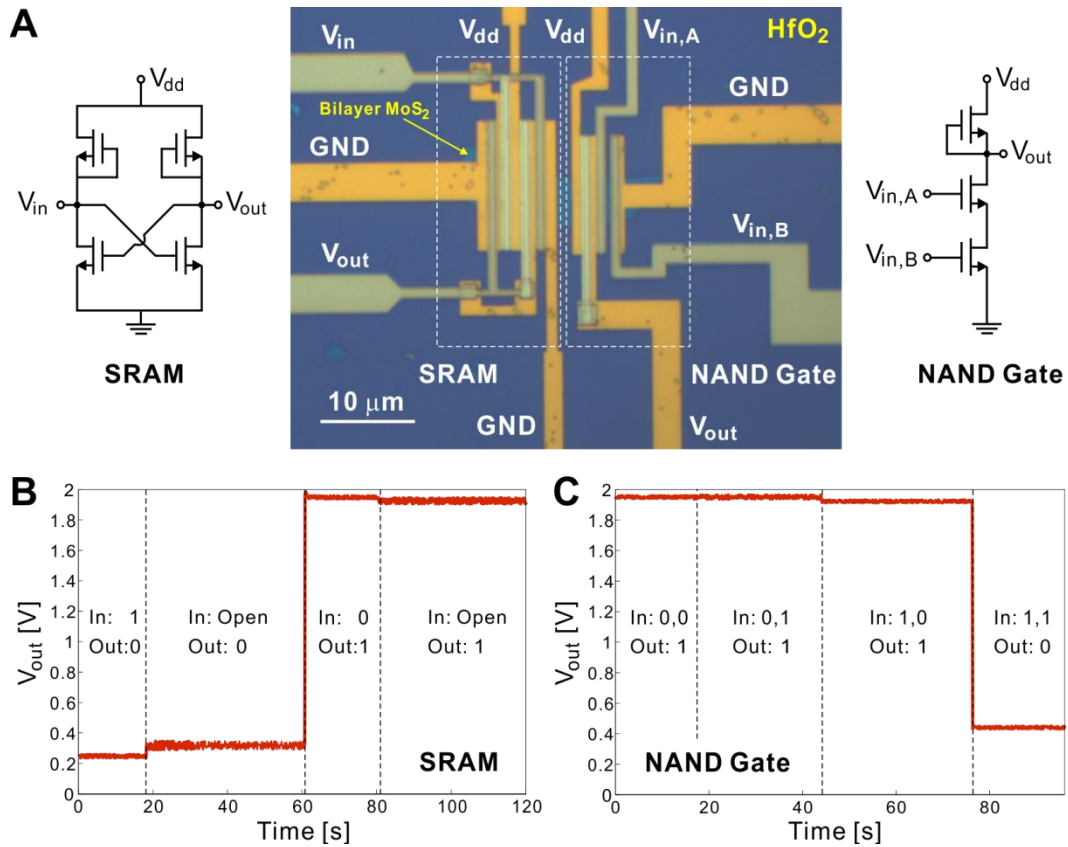

Fig. 4. Demonstration of an integrated NAND logic gate and a static random-access memory (SRAM) cell on bilayer MoS₂. **(A)** Optical micrograph of the NAND gate and the SRAM fabricated on the same bilayer MoS₂ thin film. The corresponding schematics of the electronic circuits for the NAND gate and SRAM are also shown. **(B)** Output voltage of the flip-flop memory cell (SRAM). A logic state 1 (or 0) at the input voltage can set the output voltage to logic state 0 (or 1). In addition, the output logic state stays at 0 or 1 after the switch to the input has been opened. **(C)** Output voltage of the NAND gate for four different input states: (0,0), (0,1), (1,0), and (1,1). A low voltage below 0.5 V represents a logic state 0 and a voltage close to 2 V represents a logic state 1.

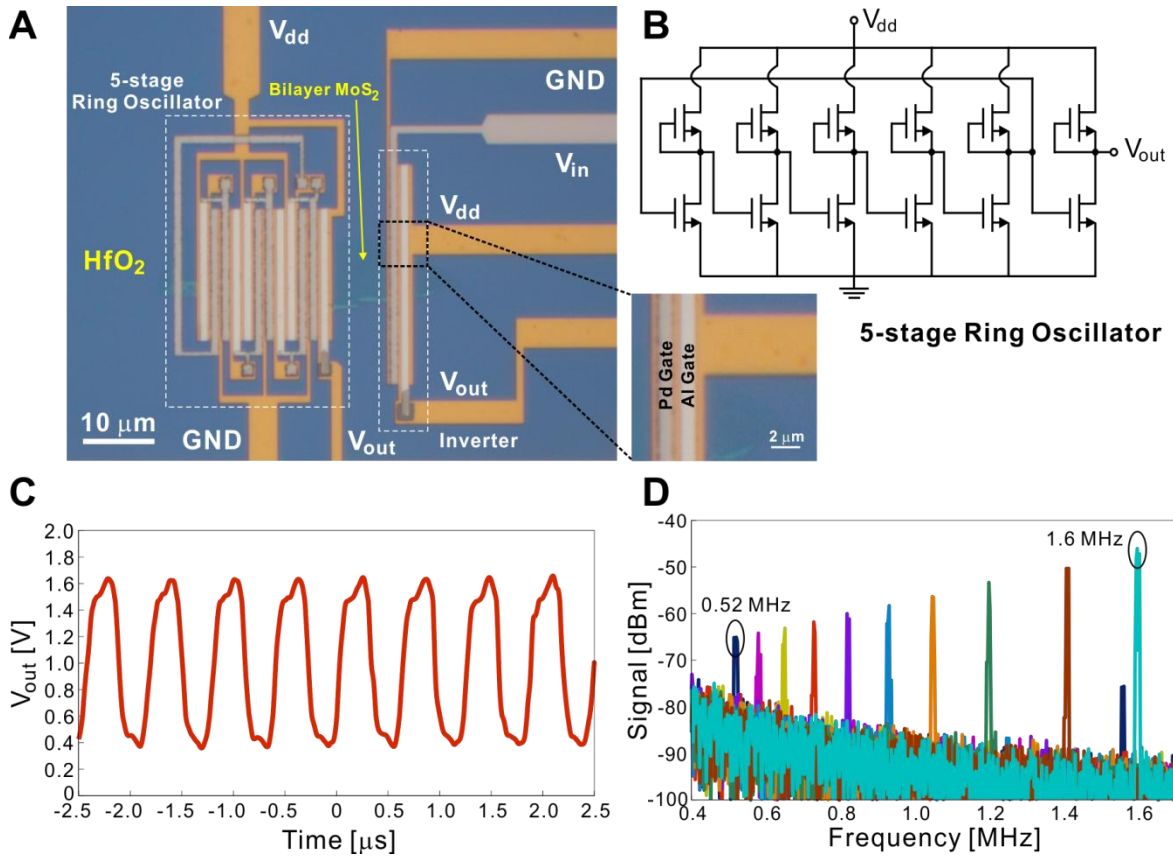
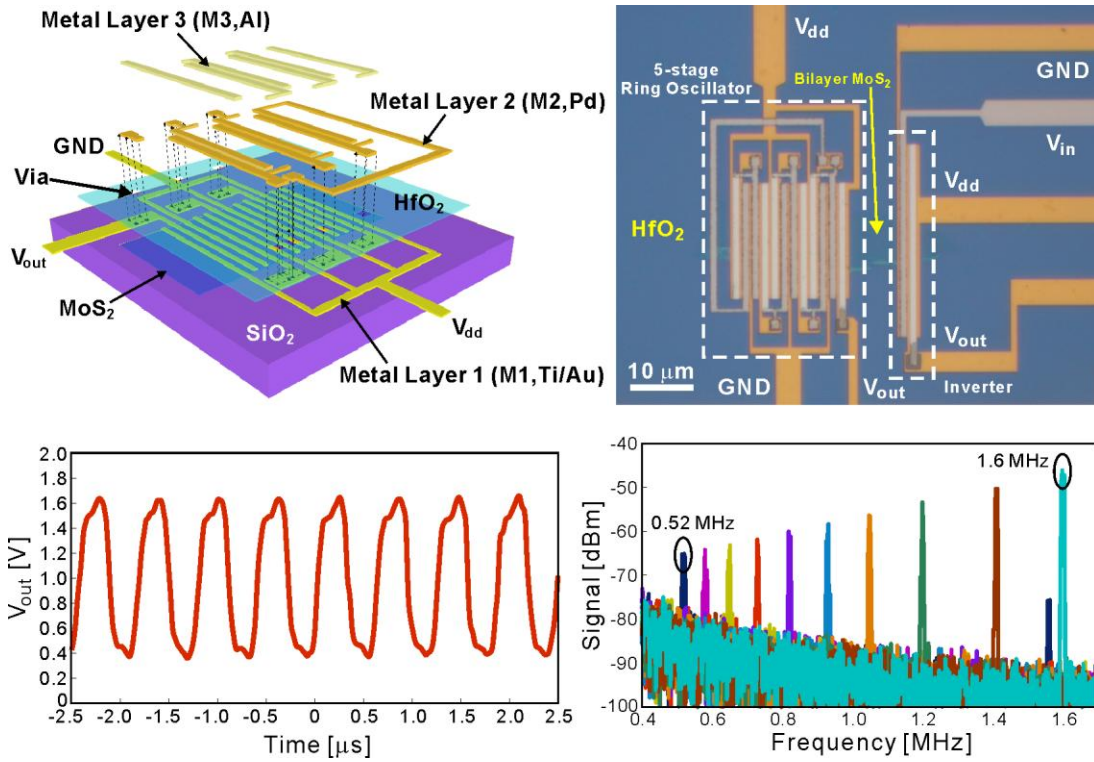

Fig. 5. A 5-stage ring oscillator based on bilayer MoS₂. **(A)** Optical micrograph of the ring oscillator constructed on a bilayer MoS₂ thin film. **(B)** Schematic of the electronic circuit of the 5-stage ring oscillator. The first five inverter stages form the positive feedback loop, which leads to the oscillation in the circuit. The last inverter stage serves as the synthesis stage. **(C)** Output voltage as a function of time for the ring oscillator at $V_{dd}=2$ V. The fundamental oscillation frequency is at 1.6 MHz. The corresponding propagation delay per stage is 62.5 ns. **(D)** The power spectrum of the output signal as a function of V_{dd} . From left to right, $V_{dd}= 1.15$ V, and 1.2 to 2.0 V in step of 0.1 V. The corresponding fundamental oscillation frequency increases from 0.52 MHz to 1.6 MHz.

Synopsis for Table of Contents



Supplementary Information

Integrated Circuits Based on Bilayer MoS₂ Transistors

H. Wang^{1,*†}, L. Yu^{1,†}, Y.-H. Lee^{1,3}, Y. Shi¹, A. Hsu¹, M. Chin², L.-J. Li³, M. Dubey², J. Kong¹, T. Palacios^{1,*}

¹Department of Electrical Engineering and Computer Science, Massachusetts Institute of Technology, 77 Massachusetts Avenue, Cambridge MA 02139, USA. Tel: +1 (617) 324-2395.

²United States Army Research Laboratory, 2800 Powder Mill Road, Adelphi, MD 20783-1197, USA.

³Institute of Atomic and Molecular Sciences, Academia Sinica, Taipei, 11529, Taiwan.

*Corresponding author E-mail: hanw@mit.edu, tpalacios@mit.edu.

[†]H. W. and L. Y. contributed equally to this work.

Methods

Device and integrated circuit fabrication: the fabrication of our devices and circuits starts with the exfoliation of MoS₂ thin films from commercially available bulk MoS₂ crystals (SPI Supplies) onto 285 nm SiO₂ on Si substrate, which has pre-patterned alignment grids (Cr/Au), using the micro-mechanical cleavage technique. The thickness of the SiO₂ was selected to provide the optimal optical contrast for locating MoS₂ flakes relative to the alignment grids and for identifying their number of layers^{S1}. The number of MoS₂ layers was then confirmed by atomic force microscopy (AFM) based on its thickness and by Raman spectroscopy based on the peak spacing between the E_{2g} mode and the A_{1g} mode, respectively^{S2}. The sample was then annealed at 350 C° in Ar 600 sccm/H₂ 30 sccm for three hours to clean away the tape residue. The next step was to pattern the first metal layer (M1), which are the electrodes directly in contact with MoS₂, i.e. source and drain of the devices, using electron-beam lithography (Elionix F125) based on poly(methyl methacrylate) (950k MW PMMA) resist. We then evaporated 3 nm Ti/ 50 nm Au followed by lift-off to form the contacts. Subsequently, the samples were annealed again at 350 °C, 600 sccm Ar/30 sccm H₂ for three hours. This annealing step reduces device resistance and also removes the PMMA residue to create a clean surface for subsequent atomic layer deposition (ALD) process. The top gate dielectric consisting of 20 nm HfO₂ was then deposited by ALD. To fabricate discrete transistors, the last step of the fabrication was to pattern the top gate electrode by electron-beam lithography, which was then formed by depositing the desired gate metal. The devices reported in this work (Fig. 2 in the main text) have $L_G=1 \mu\text{m}$ and $L_{DS}=1 \mu\text{m}$. The gate is aligned to the channel using the standard alignment techniques in e-beam lithography. For the construction of integrated logic circuits (Fig. 2B in the main text), the second and third metal layers (M2 and M3) need to be connected to the

first metal layer (M1) at certain locations depending on the design. This was achieved by patterning and etching via holes through the HfO₂ dielectric using reactive ion etching (RIE) with BCl₃/Cl₂ gas chemistry. This etching step preceded the definition of the gate metal layers M2 and M3.

AFM and Raman spectroscopy: Atomic force microscopy (AFM) for identifying the thin film thickness was performed on a Veeco DimensionTM 3100 system. Raman spectroscopy was performed with a 532 nm Nd:YAG laser. All optical micrographs were taken with a Zeiss Axio Imager.A1m microscope.

ALD and Via Hole Etching: the HfO₂ gate dielectric was deposited using ALD at 170 °C. The ALD deposition of HfO₂ was done on a commercial Savannah ALD system from Cambridge NanoTech using alternating cycles of H₂O and tetrakis(dimethylamido)hafnium (TDMAH) as the precursors. To fabricate the integrated circuits shown in this report, it is also necessary to etch via holes through the HfO₂ dielectric so that on-chip interconnections can be made between metal layer 1 and metal layers 2 and 3. We used a commercial Electron Cyclotron Resonance Reactive Ion Etcher (ECR/RIE) system (Plasma Quest) to perform this etch using BCl₃/Cl₂ gas chemistry. The ratio between the flow rates of BCl₃ and Cl₂ is 4:1. The etch rate of our low power recipe is around 6 nm/min.

Device and circuit characterization: Device characterization was performed using an Agilent 4155C semiconductor parameter analyzer and a Lakeshore cryogenic probe station with micromanipulation probes. The integrated circuits were characterized with an Agilent 54642A oscilloscope (1 MΩ input impedance) and the output signal power spectrum of the ring oscillator was measured with an Agilent N9010A Signal Analyzer (50 Ω input impedance). All measurements were done in vacuum (~10⁻⁵ Torr) at room temperature.

Identifying the number of layers in exfoliated MoS₂ thin film by AFM and Raman

The number of molecular layers in exfoliated MoS₂ thin film can be identified from measuring its thickness by atomic force microscope (AFM) and by Raman spectroscopy, based on the peak spacing between the E_{2g} mode and A_{1g} mode^{S2}. Fig. S1 shows the correspondence between the AFM data and Raman data for 1-layer (1L) to 5-layer (5L) MoS₂ flakes. After exfoliating the MoS₂ thin film onto 285 nm SiO₂/Si substrate, the flakes were first located using optical microscope and the number of molecular layers was estimated based on their optical contrast^{S1}. Then the number of layers was confirmed using both AFM and Raman spectroscopy. Bilayer MoS₂ thin films used in this report typically have a thickness around 13 Å as measured by AFM.

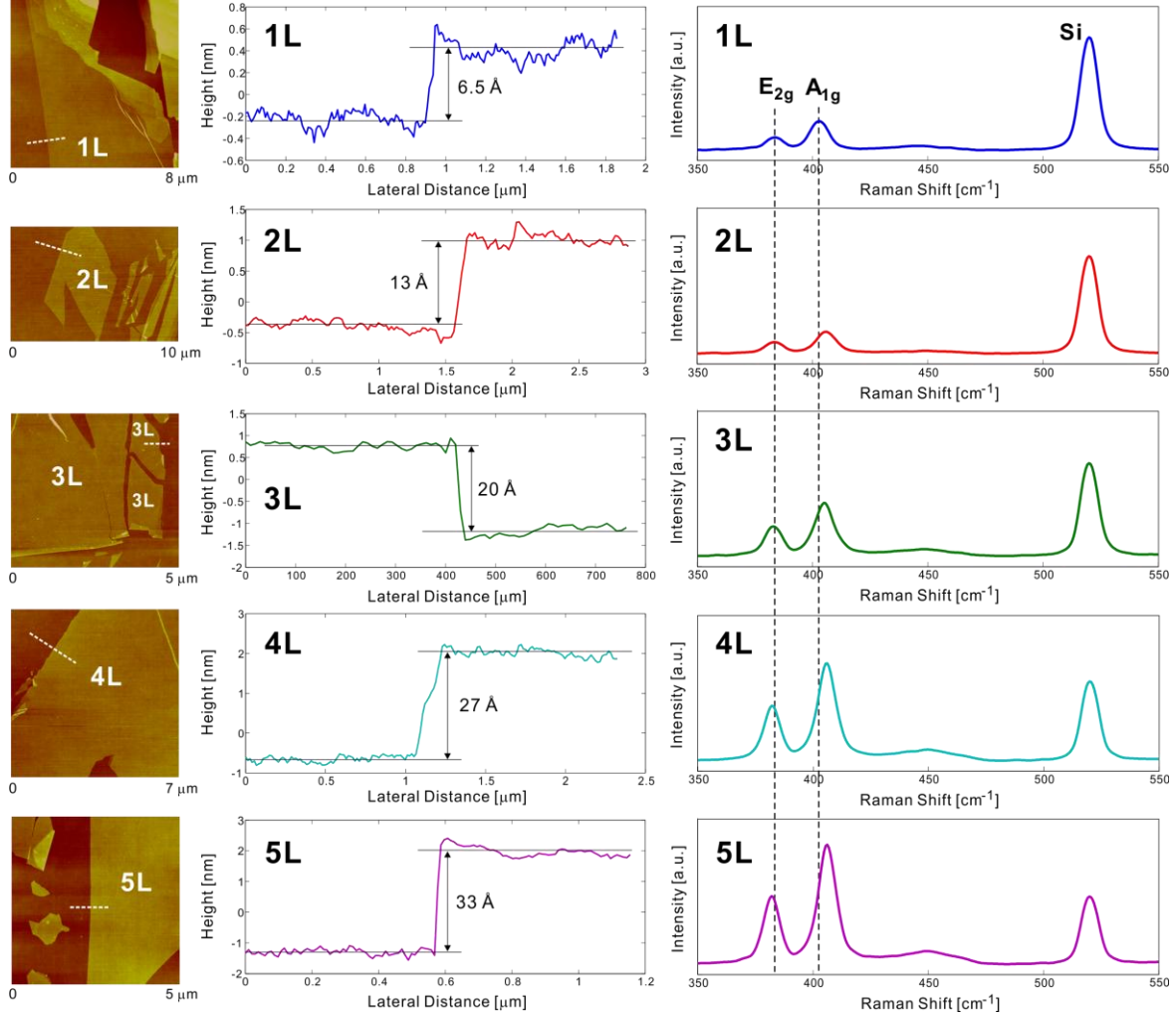

Fig. S1. Corresponding data from AFM and Raman spectroscopy measurements for one-layer to five-layer MoS₂ thin films. For each MoS₂ flake, the height information from AFM and Raman peak spacing between E_{2g} mode and A_{1g} mode are cross-checked to confirm the number of layers in the MoS₂ thin film.

Although single-layer MoS₂ FETs exhibits high on/off current ratio and low off-state current, which is important for minimizing the loss in the devices when they are turned off, it can only supply a very limited amount of current when the device is turned on (only 2.5 $\mu\text{A}/\mu\text{m}$ at $V_{\text{ds}}=0.5$ V as reported in ref. S3). Since the speed of a logic circuit is often determined by the ratio between the charge required to change the voltage across the various capacitances in the circuits and the current that can be supported by the transistors, the low on-state current in single-layer MoS₂ may limit the operation speed of any electronic systems constructed from this material. On the other hand, by increasing the number of MoS₂ layers, the on-state current of MoS₂ FETs can be increased significantly (close to 20 $\mu\text{A}/\mu\text{m}$ at $V_{\text{ds}}=0.5$ V $V_{\text{tg}}=2$ V for bilayer MoS₂ in this work) with only small degradation in terms of on/off current ratio. The higher on-state current in bilayer MoS₂ as compared to single layer MoS₂ can be due to several factors,

with the most important one being the increase in mobility with the number of MoS₂ molecular layers. The mobility of MoS₂ increases with the number of molecular layers, as reported in ref. S4. This is also evidenced by other recent results in the literature. For example, ref. S5 reported a mobility of 517 cm² V⁻¹ s⁻¹ for a 23 layer flake (15 nm thick). In this work, the bi-layer MoS₂ flake shows a mobility of 313 cm² V⁻¹ s⁻¹ while the best mobility reported for single layer MoS₂ flake is 217 cm² V⁻¹ s⁻¹ S³. For these reasons, we select bi-layer MoS₂ thin film as the material on which we demonstrate integrated logic circuits. For real electronic applications in the future, the selection of the number of layers may depend on the type of application. If better frequency performance is needed, then multi-layer MoS₂ may be used. If ultra-low power performance is necessary, then single-layer MoS₂ may be a better choice. And bi-layer and tri-layer MoS₂ thin films may offer good trade-off in between. In short, the capability to control the number of molecular layers in the 2D crystal and the consequent control of the electronic properties enables added flexibility in this material system. In the future, it may be possible to build integrated circuits where different sections of the IC use different number of layers of MoS₂ thin films. The high performance sections (e.g. analog to digital converters, high speed oscillators) can use multilayer MoS₂ thin films while the low loss section (e.g. memory units) can use fewer layer of MoS₂ thin films.

Work function Difference between Al and Pd

To build both depletion-mode and enhancement-mode FETs on the same sheet of MoS₂, we use metals with different work functions, w_M , as the gates to control the threshold voltages of the FETs. Fig. S2 shows the band diagram of FETs with gate metal work function either greater than the semiconductor work function, i.e. $w_M > w_S$, or smaller than the semiconductor work function, i.e. $w_M < w_S$. A low work function metal tend to induce electrons in the channel, tuning the channel to the charge accumulation regime; while a high work function metal can induce the channel into the charge depletion regime, all at zero gate bias. For the Al-gate and Pd-gate MoS₂ FETs reported in this work, the shift in threshold voltage is around 0.76 V, which changes the threshold voltage from negative to positive and confers MoS₂ both enhancement-mode and depletion-mode FETs (Fig. 2C and 2D in the manuscript).

The difference between the work functions of two metals on a dielectric is generally different from that in vacuum. This phenomenon may be characterized quantitatively by the S parameter, which accounts for dielectric screening. It can be calculated as the ratio between the effective metal work-function difference on a dielectric to that in vacuum:

$$\Phi_{M,\text{eff}} = \Phi_{\text{CNL,d}} + S (\Phi_{M,\text{vac}} - \Phi_{\text{CNL,d}})$$

where $\Phi_{M,eff}$ is the effective work function of the metal in a dielectric and $\Phi_{M,vac}$ is the work function of the same metal in vacuum. $\Phi_{CNL,d}$ is the charge neutrality level of the dielectric. The difference between the effective work functions of two metals can then be related to their difference in vacuum: $\Delta \Phi_{M,eff} = \Delta \Phi_{M,vac}$. Since $\Delta \Phi_{M,eff}$ and $\Delta \Phi_{M,vac}$ are about 0.76 and 1.04 eV, respectively, we have $S \sim 0.7$ for the metals on HfO_2 , which agrees closely with the value reported in ref. S6.

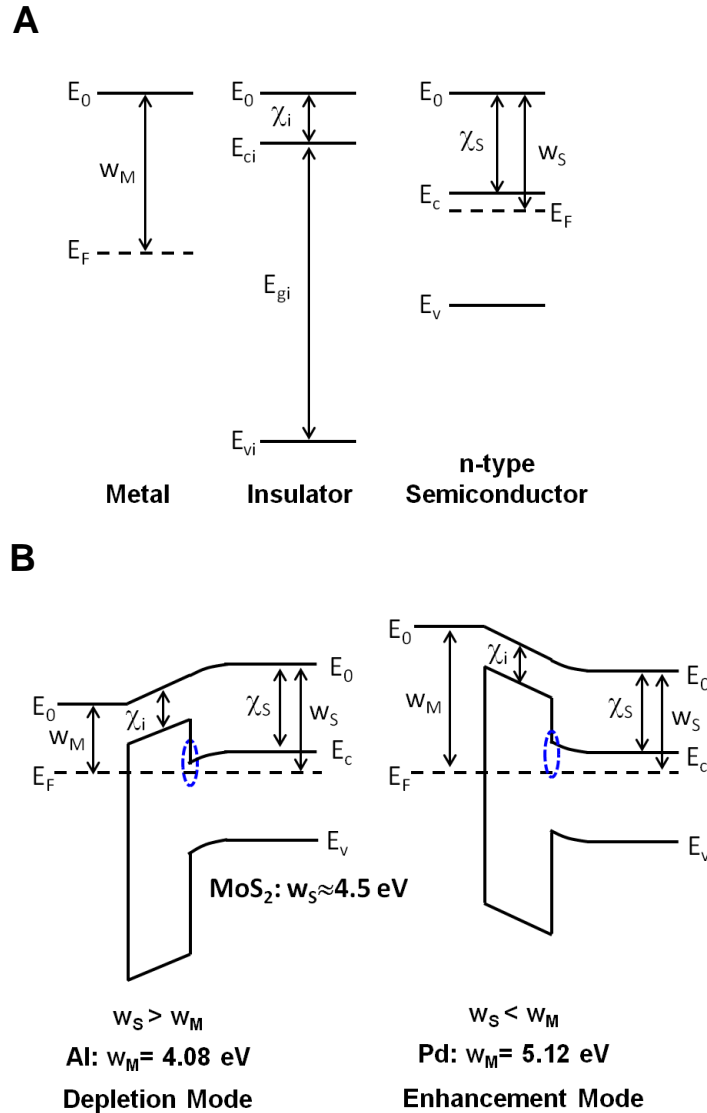

Fig. S2. Energy band diagrams **(A)** for isolated metal, insulator and semiconductor, and **(B)** after bringing them in intimate contact and thermal equilibrium is established. Depending on the different pairing of metal and semiconductor work functions, the metal-oxide-semiconductor (MOS) structure can induce the channel into either accumulation regime (for depletion mode FET) or depletion regime (for enhancement mode FET).

Mobility Extraction

The mobility of the bilayer thin films is extracted using the back-gate characteristics based on the expression $\mu = [dI_{ds}/dV_{bg}] \times [L/(WC_g V_{ds})]$. $W=4 \mu\text{m}$ is the width of the device. $L=1 \mu\text{m}$ is the gate length. C_g is the gate capacitance per unit area, which is based on 285 nm SiO_2 for the back gate. $V_{ds}=1\text{V}$ is the bias applied at the drain electrode relative to the source electrode.

Typical field effect mobility measured based on this two-contact method is around $5\text{-}15 \text{ cm}^2 \text{ V}^{-1} \text{ s}^{-1}$ for bilayer MoS_2 . After the deposition of HfO_2 , the extracted mobility increases to above $300 \text{ cm}^2 \text{ V}^{-1} \text{ s}^{-1}$ (Fig. S3). This significant increase in mobility after the deposition of high-k dielectric agrees with the observation in ref. S3, which is attributed to the suppression of Coulomb scattering by the high-k dielectric environment^{S7} and spatial-confinement-induced modification of the acoustic phonon spectrum in bilayer MoS_2 ^{S8}. The complete understanding of this improvement will, however, need further theoretical and experimental studies. The field-effect mobility extracted using this method represents a conservative estimate of the mobility value because of effect of contact resistance^{S3,S5}, which was not de-embedded in the measurements.

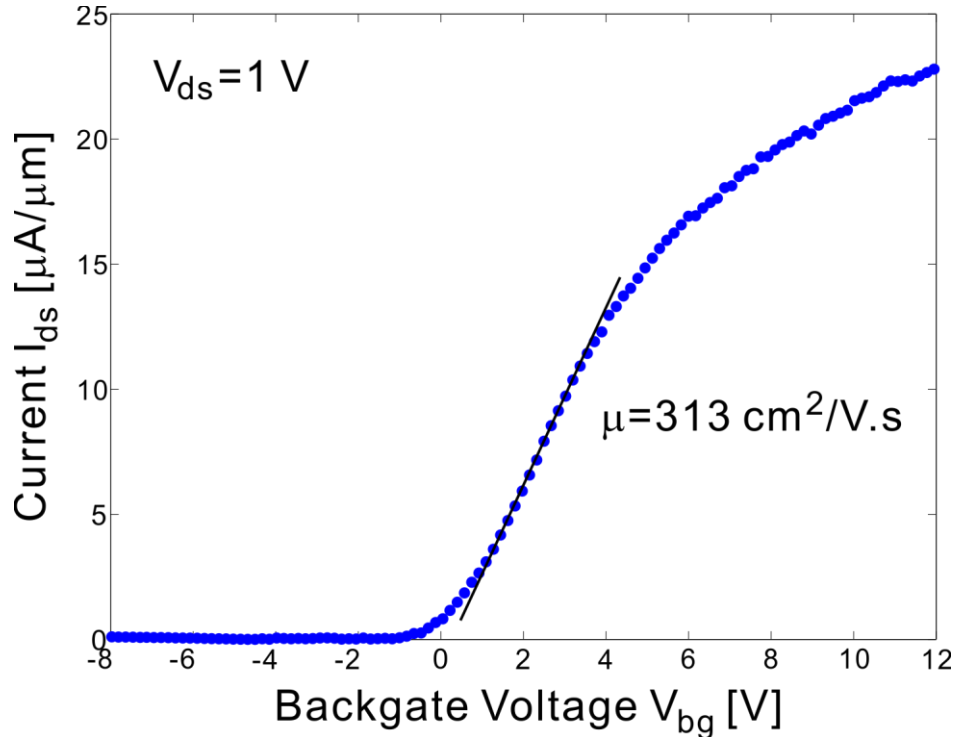

Fig. S3. Extraction of field-effect mobility based on back-gate characteristics of the device. The measurement is done at room temperature in vacuum ($\sim 10^{-5}$ Torr).

Estimation of the Ring Oscillator Speed

We can estimate the expected oscillation frequency for the ring oscillator at $V_{dd}=2$ V based on the parasitic capacitances present at various parts of the circuit and the driving current supported by the FETs as follows^{S9,S10}:

- a. The average driving current I_{ds} can be estimated from Fig. 3A of the report. Each inverter stage operates along the load line defined by the depletion-mode FET. Since the width of the FETs in the ring oscillator circuit is about 11 μm , we have $I \approx 22 \mu\text{A}$ for $V_{dd}=2$ V.

The parasitic capacitance in the circuit is mainly contributed by two parts:

- b. capacitances due to the overlap area between the top gate layers (M2 and M3) and the source/drain layer (M1). This capacitance is mainly due to the gate capacitance of the 12 FETs in the circuit as well as the overlap between the interconnects in the gate metal layers (M2 and M3) and that in the M1 layer. The gate capacitance of the 12 FETs are estimated based on their device width (about 11 μm on average for each FET), and their gate length (1 μm for each FET) with 20 nm HfO_2 (dielectric constant ~ 22) as the dielectric material. This leads to capacitances of 1.285 pF. The remaining overlap area between the interconnects is around 5.3 μm^2 , which gives an additional 0.051 pF. The total gate overlap capacitance is hence:

$$C_{ov_gate} = 1.336 \text{ pF}$$

- c. capacitances contributed by the conductive Si substrate with 285 nm SiO_2 :

$$C_{ov_Si} = 2.138 \text{ pF}$$

Hence, the estimated total parasitic capacitances per stage is equal to:

$$C \approx (C_{ov_gate} + C_{ov_Si})/6 = 0.579 \text{ pF}$$

The propagation delay per stage is estimated to be: $\tau_{pd} = CV_{dd}/I = 52.6$ ns.

Thus, at $V_{dd}=2$ V, the expected frequency for a 5-stage ring oscillator is equal to: $f = 1/(2n\tau_{pd}) = 1.9$ MHz.

This is very close to the measured value of the oscillation frequency, which is 1.6 MHz.

References

- S1. Benameur, M. M. *et al.* Visibility of dichalcogenide nanolayers. *Nanotechnology* **22**, 125706 (2011).
- S2. Lee, C. *et al.* Anomalous lattice vibrations of single- and few-layer MoS_2 . *ACS Nano* **4**, 2695–2700 (2010).

- S3. Radisavljevic, B., Radenovic, A., Brivio, J., Giacometti, V. & Kis, A. Single-layer MoS₂ transistors. *Nature Nanotechnology* **6**, 147–150 (2011).
- S4. Li, H. *et al.* Fabrication of single- and multilayer MoS₂ film-based field-effect transistors for sensing NO at room temperature. *Small* **8**, 63–67 (2012).
- S5. Liu, H. & Ye, P. D. MoS₂ dual-gate MOSFET With atomic-layer-deposited Al₂O₃ as top-gate dielectric. *IEEE Electron Device Letters* **33**, 546–548 (2012).
- S6. Gu, D., Dey, S. K. & Majhi, P. Effective work function of Pt, Pd, and Re on atomic layer deposited HfO₂. *Applied Physics Letters* **89**, 082907–082907–3 (2006).
- S7. Jena, D. & Konar, A. Enhancement of carrier mobility in semiconductor nanostructures by dielectric engineering. *Phys. Rev. Lett.* **98**, 136805 (2007).
- S8. Fonoberov, V. A. & Balandin, A. A. Giant enhancement of the carrier mobility in silicon nanowires with diamond coating. *Nano Lett.* **6**, 2442–2446 (2006).
- S9. Ayers, J. E. *Digital integrated circuits: analysis and design*. (CRC Press: 2004).
- S10. Chen, Z. *et al.* An integrated logic circuit assembled on a single carbon nanotube. *Science* **311**, 1735 (2006).