

ANALYTICAL MODELING OF A BUBBLE COLUMN DEHUMIDIFIER

Emily W. TowRohsenow Kendall Heat Transfer Laboratory
Department of Mechanical Engineering
Massachusetts Institute of Technology
Cambridge, Massachusetts 02139
Email: emilytow@mit.edu**John H. Lienhard V***Rohsenow Kendall Heat Transfer Laboratory
Department of Mechanical Engineering
Massachusetts Institute of Technology
Cambridge, Massachusetts 02139
Email: lienhard@mit.edu**ABSTRACT**

Bubble column dehumidifiers are a compact, inexpensive alternative to conventional fin-tube dehumidifiers for humidification-dehumidification (HDH) desalination, a technology that has promising applications in small-scale desalination and industrial water remediation. In this paper, algebraic equations for relevant mean heat and mass transfer driving forces are developed for improved modeling of bubble column dehumidifiers. Because mixing in the column ensures a uniform liquid temperature, the bubble column can be modeled as two single stream heat exchangers in contact with the column liquid: the seawater side, for which a log-mean temperature difference is appropriate, and the gas side, which has a varying heat capacity and mass exchange. Under typical conditions, a log-mean mass fraction difference is shown to drive latent heat transfer, and an expression for the mean temperature difference of the moist gas stream is presented. These expressions will facilitate modeling of bubble column heat and mass exchangers.

NOMENCLATURE

A	Surface area [m ²]
C	Heat capacity flow rate [J/K-s]
c_p	Specific heat at constant pressure [J/kg-K]
D	Bubble diameter [m]
Fo	Fourier number [-]
H	Column liquid height, measured during bubbling [m]
h	Specific enthalpy [J/kg] or heat transfer coefficient [W/m ² -K]

h_{fg}	Latent heat of vaporization of water [J/kg]
K	Mass transfer coefficient [kg/m ² -s]
K^*	Dimensionless mass transfer coefficient [-]
k	Thermal conductivity [W/m-K]
L	Equivalent length [m]
Le_f	Lewis factor [-]
M	Molar mass [kg/kmol]
m	Water vapor mass fraction [-]
\dot{m}	Mass flow rate [kg/m ²]
p	Pressure [Pa]
P	Equivalent wetted perimeter [m]
\dot{Q}	Heat transfer rate [J/s]
R	Specific gas constant [J/kg-K]
T	Temperature [K]
U	Overall heat transfer coefficient [W/m ² -K]
U^*	Dimensionless heat transfer coefficient [-]
u	Superficial velocity [m/s]
\dot{V}	Volumetric flow rate [m ³ /s]
v	Bubble rise velocity [m/s]
x	Distance [m]
x^*	Dimensionless distance [-]

Greek

α	Thermal diffusivity [m ² /s]
Δ	Mean difference
ε	Gas holdup [-]
Θ	Dimensionless temperature difference [-]
ρ	Density [kg/m ³]

*Address all correspondence to this author.

Subscripts

<i>A</i>	Bubble
<i>a</i>	Dry air
<i>B</i>	Bubble inner surface
<i>C</i>	Column liquid
<i>coil</i>	Coil and coolant fluid
<i>cond</i>	Condensation
<i>D</i>	Coil metal
<i>E</i>	Coolant
<i>e</i>	Entry
<i>i</i>	In
<i>l</i>	Latent heat
<i>LM</i>	Log mean
<i>ma</i>	Moist air
<i>o</i>	Out
<i>s</i>	Sensible
<i>sat</i>	Saturation
<i>turn</i>	Coil turn
<i>w</i>	Water vapor

INTRODUCTION

The development of energy-efficient desalination technologies with low capital and maintenance costs is critical to combating global fresh water scarcity. Humidification-dehumidification (HDH) is a promising desalination process because of its simple system design and compatibility with low-grade energy [1, 2]. However, the high cost of conventional dehumidifiers due to the large amount of copper required inhibits the use of HDH in poor and remote regions where its low-tech nature could be most useful.

Bubble column dehumidifiers reduce cost by moving the condensation process from expensive copper plates to the inner surface of bubbles in fresh water. In a bubble column dehumidifier, shown in Fig. 1, moist gas (usually air) is bubbled through a sparger into a column of fresh water cooled by a small coil running cold fluid (usually seawater). The high resistance to water vapor mass diffusion expected in dehumidifiers due to the high concentration of non-condensable gasses [1] is overcome by condensing on a very large surface area of bubbles. Heat transfer coefficients between the liquid in the column and the cooling coil are so high that only a small copper coil is needed, thereby reducing the cost of the dehumidifier dramatically [3].

Simple and accurate modeling of bubble column dehumidifiers (and bubble column humidifiers, which may also prove useful in HDH) will enable optimization of column designs for performance and cost. Developing algebraic equations such as the log-mean temperature difference (LMTD) to model heat transfer driving forces in parallel-flow and counterflow heat exchangers is useful because it eliminates the need for integration of differential equations. However, the use of LMTD to approximate the mean temperature difference relies on the assumption of constant

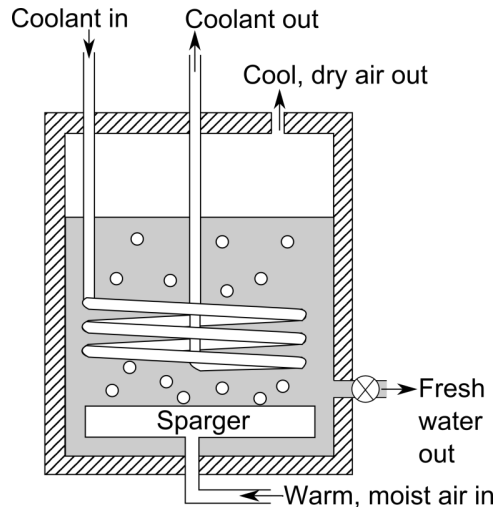

FIGURE 1. BUBBLE COLUMN DEHUMIDIFIER

heat capacity in each stream and does not allow for the thermal energy left in the stream by warm water vapor molecules diffusing down a temperature gradient coincident with the concentration gradient. Mills provides a clear derivation of LMTD [4]. This paper will follow a similar method to derive mean heat and mass transfer driving forces, but will account for mass transfer and the resulting change in the heat capacity of the moist air stream. Many authors have proposed mean temperature differences or corrections to LMTD for other heat exchanger configurations [5].

Failure to recognize the assumptions made in the derivation of LMTD has led some researchers to use it in heat and mass exchangers such as dehumidifiers. In their model of a bubble column dehumidifier, Narayan et al. [3] used a single-stream LMTD to model the sensible heat transfer driving force from the moist air stream to the column fluid. Similarly, Chen et al. [6] used LMTD to model the sensible heat transfer from the moist air in a plate-fin tube dehumidifier. This work will show that although the standard LMTD is inappropriate for streams with mass exchange, the error in sensible heat transfer predicted will be on the order of 10%. Since the majority of the heat removed from the moist air is latent, the error in the total predicted heat transfer rate due to modeling the moist air stream with LMTD is small, but if possible, a simple algebraic equation for mean temperature difference in a dehumidifier that accounts for mass transfer and the corresponding changes in heat capacity flow rate should be employed.

Both Narayan et al. and Chen et al. used a log-mean humidity (in kg water/kg dry air) difference to model the mass transfer driving force. Mills [7] uses a mass fraction driving force for mass transfer in his model of a humidifier which leads to a mass fraction profile similar to the one developed in this paper for a

dehumidifier.

Experiments demonstrate that mixing in the bubble column ensures an essentially uniform liquid temperature, so the bubble column will be modeled as two single stream heat exchangers of equal heat transfer rate in contact with the isothermal column liquid: the seawater side, for which LMTD is appropriate, and the gas side, which has mass exchange. Under conditions typical of these systems, a log-mean mass fraction difference will be shown to relate the latent heat transfer to the overall mass transfer coefficient on the air side. An expression for the mean temperature difference of the moist gas and an algebraic approximation will be presented. Given knowledge of the heat and mass transfer coefficients of the bubbles and cooling coil, the model developed in this paper enables calculation of the condensation rate, total heat transfer rate, and temperature pinch of a single stage bubble column dehumidifier or humidifier.

THEORY

The dehumidifier will be modeled as two single-stream heat exchangers interacting with the same isothermal stream, one of which has mass exchange. For the stream with mass exchange, mean heat and mass transfer driving forces will be found following a method analogous to that used to derive LMTD [4]. The equations and narrative will assume the device under consideration is a dehumidifier, but the model applies equally to a humidifier as long as careful attention is paid to signs.

Heat and Mass Exchanger Model

The bubble column as a whole behaves like a parallel-flow device because both the moist air and coolant streams interact with the column fluid, which is very well-mixed by the bubbles and can be treated as isothermal. Because the coil is small compared to the volume of bubbles, it will be assumed that the bubbles do not have significant thermal interactions with the coil that are unmediated by the column fluid. Similarly, heat transfer between the air stream and the coil in the air gap above the bubble column will be disregarded by this analysis [8]. Figure 2 shows a simplified resistance network model of the system, where node B is the inner surface of the bubble on the gas side, node C is the column fluid, D is the average tube temperature, and A and E represent average stream temperatures of the bubbles and coolant, respectively. For a steady pool temperature, both the sensible heat transfer from A to B and the latent heat released by condensation at B are transferred through the rest of the resistance network to the coolant. The total heat transfer into the coolant fluid is

$$\dot{Q}_{coil} = \dot{m}_{coil} c_{p,coil} [T_{coil,o} - T_{coil,i}], \quad (1)$$

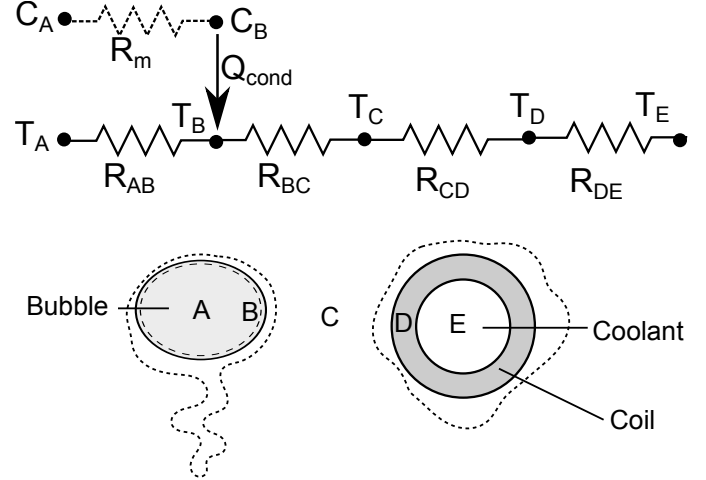

FIGURE 2. RESISTANCE NETWORK MODEL, WITH TEMPERATURES (T), CONCENTRATIONS (C), AND RESISTANCES (R)

assuming constant specific heat of the coolant liquid, and

$$\dot{Q}_{coil} = (UA\Delta T_{LM})_{coil} \quad (2)$$

where $(UA)_{coil}$ is based on the forced convection both inside and outside the coil. The LMTD for a single-stream heat exchanger with no mass exchange, and whose non-isothermal stream experiences a positive heat transfer is, as usual,

$$\Delta T_{LM} = \frac{T_o - T_i}{\ln \left(\frac{T_i - T_C}{T_o - T_C} \right)}. \quad (3)$$

It is assumed that the temperature difference across the thin boundary layer outside the bubble is very small compared to the temperature difference inside the bubble because water has a much greater thermal conductivity and smaller thermal diffusivity (and thus much thinner boundary layer) than air. This will be discussed in greater detail in the following section, but the result of this assumption is that the resistance between B and C can be neglected, and the moist air stream can be modeled as interacting directly with the isothermal column fluid. This approximation greatly simplifies modeling.

Applying conservation of energy to the entire air stream, as in Fig. 3,

$$0 = \dot{Q}_s + \dot{m}_a [h_a(T_i) - h_a(T_o)] + \dot{m}_{w,o} [h_w(T_i) - h_w(T_o)] + (\dot{m}_{w,i} - \dot{m}_{w,o}) [h_w(T_i) - h_w(T_C)], \quad (4)$$

and assuming constant specific heat capacities of the air and wa-

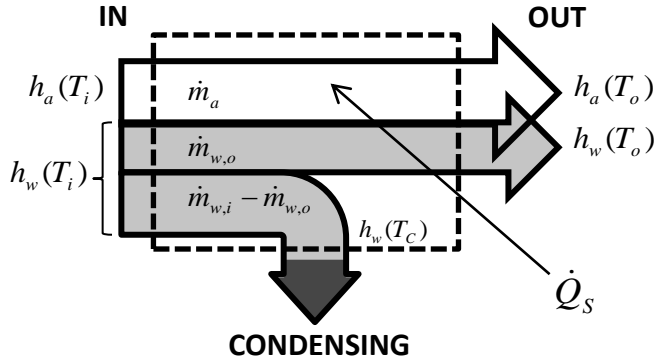

FIGURE 3. CONSERVATION OF ENERGY FOR AIR STREAM WITH CONDENSATION OCCURRING JUST OUTSIDE THE CONTROL VOLUME

ter vapor such that

$$h_a(T_1) - h_a(T_2) = c_{p,a}[T_1 - T_2] \quad (5)$$

and

$$h_w(T_1) - h_w(T_2) = c_{p,w}[T_1 - T_2], \quad (6)$$

Eqn. (7) gives the sensible heat transfer rate into the moist air, which in the case of a dehumidifier will be negative:

$$\begin{aligned} \dot{Q}_s = & (\dot{m}_a c_{p,w} + \dot{m}_{w,o} c_{p,o})(T_o - T_i) \\ & + c_{p,w}(\dot{m}_{w,i} - \dot{m}_{w,o})(T_c - T_i). \end{aligned} \quad (7)$$

In this equation, the first righthand side term represents the sensible heat lost by the moist air stream that passes through the column and the second represents the sensible cooling of water vapor that diffuses to the liquid surface, at T_c , and condenses there. The latent heat of vaporization is not present in Eqn. (7) because the heat released is absorbed on the liquid side of the bubble surface, which is not part of the air stream. The latent heat transfer rate into the liquid can be computed from the change in water vapor mass flow rate in the moist air stream, which is equal to the rate of condensation:

$$\dot{Q}_l = h_{fg}(\dot{m}_{w,i} - \dot{m}_{w,o}) = h_{fg}(\dot{m}_{cond}). \quad (8)$$

Assuming no heat is lost to the environment, the total steady heat transfer rate into the coolant is the sum of the latent and sensible heat transfers to the column fluid:

$$\dot{Q}_{coil} = -\dot{Q}_s + \dot{Q}_l = \dot{m}_{coil} c_{p,coil}[T_{coil,o} - T_{coil,i}]. \quad (9)$$

Heat and Mass Transfer Coefficients

It is important to verify the assumption of constant heat and mass transfer coefficients that will be employed in the driving force model. However, detailed modeling of heat and mass transfer coefficients is beyond the scope of this paper. Because bubble columns have primarily been used for gas-liquid reactions where the mass transfer is controlled by the diffusion of the gas into a liquid, many past studies have addressed the heat and mass transfer coefficients outside a rising bubble and neglected any resistance inside [9]. To show that the inner transfer coefficient can be assumed constant for driving force modeling purposes, a scaling argument can be used to approximate the entry length over which the heat and mass transfer coefficients inside the bubble reach steady values. Inside the bubble, diffusion and convection may both contribute to the heat and mass transfer, but a conservative estimate of entry length will assume that no convection occurs (since convection would shorten the entry length). Bubble velocity is estimated with Mendelson's wave analogy to be around $v = 0.2$ m/s [10]. The bubble is within its entry length at short times, around $Fo \leq 0.2$, when the thermal boundary layer inside the bubble is still developing [4]. Under typical conditions, the entry length for a bubble of diameter $D = 4$ mm can be approximated by Eqn. (10):

$$L_e = vt \approx \frac{vFoD^2}{4\alpha} \approx 7 \text{ mm} \quad (10)$$

Since a typical bubble column is at least 150 mm deep to ensure immersion of the cooling coil [3], the entry region is a sufficiently small fraction of the column that the constant heat transfer coefficient assumption is appropriate. Assuming a Lewis number of order 1 for the moist air, the mass diffusion entry length is comparable, so a constant mass transfer coefficient can also be assumed.

The heat transfer coefficients inside and outside the coil can also be taken to be constant along the length of the coil. In laminar flow, secondary flows induced by the coil curvature significantly reduce the radial length scale for convection (see Mori and Nakayama [11]) compared to a straight tube, thus shortening the thermal entry length inside the coil. These secondary flows also significantly raise the inside heat transfer coefficient above the straight pipe value, scaling as $h_{DE} \sim (D_{coil}/D_{turn})^{1/4}$, where D_{turn} is the diameter of coil winding. For example, the curved pipe Nusselt number was nearly ten times the straight pipe value for the cooling coil used in the bubble column dehumidifier tested in [8]. In turbulent flow, a short entry length is expected regardless of coil curvature, though the curvature-induced augmentation of the heat transfer coefficient does extend, to a lesser extent, into turbulent flow [12]. Outside the coil, the heat transfer coefficient is expected to be approximately constant so long as the flow conditions are consistent in the vicinity

of the entire coil, e.g. for a single loop placed centrally on a symmetrical sparger.

Estimating the heat and mass transfer coefficients inside and outside the bubble will help verify the approximation of a negligible temperature gradient outside the bubble. The bubbles are large enough that the bubble surface can be treated as free, and the temperature profiles both inside and outside can be approximated as semi-infinite slabs moving at the bubble terminal velocity. The thermal boundary layer will grow as $\sqrt{\pi\alpha x/v}$. Using a characteristic length of the bubble diameter, the heat transfer coefficient can then be approximated by conduction through the boundary layer thickness as in Eqn. (11):

$$h \approx k \sqrt{\frac{v}{\pi\alpha D}} \quad (11)$$

For typical dehumidifier operation temperatures and 4 mm bubbles, $h_{AB} \approx 20 \text{ W/m}^2\text{-K}$ and $h_{BC} \approx 7000 \text{ W/m}^2\text{-K}$, confirming the assumption that $h_{AB} \ll h_{BC}$. Even considering that the heat transfer rate outside the bubble is greater due to the latent heat transferred to the bubble surface, the heat transfer coefficient outside the bubble should be so much greater that the temperature difference between B and C can be neglected in the analysis of the mean heat and mass transfer driving forces.

Equivalent Length and Perimeter

For simplicity, the bubble stream will be modeled as a stream having an equivalent length and perimeter. The equivalent length L is related to the superficial (u) and terminal (v) velocities, gas holdup ε and column liquid height H by Eqn. (12).

$$L = \left(\frac{v}{u}\right) \varepsilon H \quad (12)$$

A wide array of experimental correlations for holdup can be found in the literature, depending on the choice of gas and liquid, operating conditions, sparger design, and column configuration [13].

The equivalent perimeter, P , which satisfies the relationship $PL = A$, where A is the total surface area of bubbles entrained in the column, is

$$P = \frac{6\dot{V}_{ma,i}}{vD}, \quad (13)$$

assuming spherical bubbles, a negligible change in bubble surface area due to vapor condensation and temperature change, and a nearly constant rise velocity. The density of the moist air can be calculated by assuming an ideal mixture of air and water vapor.

In high orifice velocity gas sparging, bubbles will be neither spherical nor uniform in size, and correlations from the literature for interfacial area should be used to compute the effective perimeter [14].

Mass Fraction Profile

The condensation rate is regulated by diffusion of water vapor through the moist air to the bubble surface, which is assumed to have the temperature of the column fluid. The partial pressure of water vapor at the bubble surface is equal to the saturation pressure at that temperature. It will be assumed that no mist forms inside the bubbles and that all condensation occurs at the bubble surface.

Mass transfer is examined through a differential control volume of length dx with a mass fraction-based mass transfer coefficient K with units of $[\text{kg/m}^2\text{-s}]$ such that:

$$d\dot{m}_{cond}(x) = KPdx[m(x) - m_C]. \quad (14)$$

In Eqn. (14), a dilute mixture of water vapor in air is assumed such that a mass fraction difference can represent the mass transfer driving force, as in Mills' humidifier model [7]. The saturated bubble surface mass fraction is

$$m_C = \frac{p_{sat}(T_C)}{R_w T_C \rho_{ma}(T_C)}. \quad (15)$$

Steady-state conservation of mass demands that

$$d\dot{m}_{cond}(x) = \dot{m}_w(x) - \dot{m}_w(x + dx), \quad (16)$$

so the differential equation for water mass flow rate becomes:

$$\frac{d\dot{m}_w(x)}{dx} = -KP[m(x) - m_C]. \quad (17)$$

Assuming the change in moist air mass flow rate is small,

$$\frac{\dot{m}_{cond}}{\dot{m}_{ma,i}} \ll 1, \quad (18)$$

then

$$\dot{m}_w(x) \approx m(x)\dot{m}_{ma,i} \quad (19)$$

and

$$\frac{dm(x)}{dx} = -\frac{KP}{\dot{m}_{ma,i}}[m(x) - m_C]. \quad (20)$$

Solving for $m(x)$ and applying the boundary condition $m(x=0) = m_i$ gives the water mass fraction profile:

$$m(x^*) = m_C + [m_i - m_C]e^{(-K^*x^*)}, \quad (21)$$

where

$$x^* = \frac{x}{L} \quad (22)$$

and the mass transfer NTU, K^* , is:

$$K^* = \frac{KPL}{\dot{m}_{ma,i}}. \quad (23)$$

Mean Mass Fraction Difference

The mean mass fraction difference, Δm , is defined by:

$$\Delta m = \frac{\dot{m}_{cond}}{KPL}. \quad (24)$$

Evaluation of Eqn. (21) at the outlet gives the expected outlet mass fraction:

$$m_o = m_C + [m_i - m_C]e^{(-K^*)} \quad (25)$$

Combining Eqns. (19), (23), (24) and (25) gives the mean mass fraction difference, which in this case is a log mean mass fraction difference:

$$\Delta m = \frac{m_i - m_o}{\ln\left(\frac{m_i - m_C}{m_o - m_C}\right)}. \quad (26)$$

The log-mean density difference can be used in Eqn. (24) to find the condensation rate, which can then be used in Eqn. (8) to compute the latent heat transfer rate.

Temperature Profile

The sensible heat transfer from the bubbles to the column fluid is regulated by the temperature difference between the bulk air and the bubble surface. Figure 4 illustrates conservation of mass and energy on a differential control volume of moist air inside the bubble, modeled as a stream with equivalent length and perimeter:

$$d\dot{Q}_s = d\dot{m}_{cond}h_w(T_C) + \dot{m}_a[h_a(x+dx) - h_a(x)] + \dot{m}_w(x+dx)h_w(T(x+dx)) - \dot{m}_w(x)h_w(T(x)), \quad (27)$$

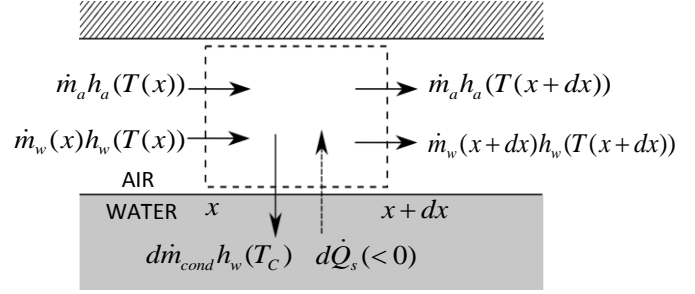

FIGURE 4. CONSERVATION OF ENERGY ON A DIFFERENTIAL CONTROL VOLUME OF MOIST AIR

where the sensible heat transfer rate into the differential element is

$$d\dot{Q}_s = -UPdx[T(x) - T_C] \quad (28)$$

and $d\dot{m}_{cond}$ is defined by Eqn. (16).

The latent heat of vaporization does not appear in the first law for the chosen control volume because the diffusing water leaves as vapor and condenses just outside the control volume. The latent heat is then assumed to be carried away across the thin liquid-side thermal boundary layer into the well-mixed column.

Taking the limit of small dx leads to the differential form of conservation of energy, assuming, again, constant specific heats.

$$0 = \left(c_{p,w} \frac{d\dot{m}_w}{dx} + UP\right)(T(x) - T_C) + c_{p,w}\dot{m}_w(x) \frac{dT}{dx} + c_{p,a}\dot{m}_a \frac{dT}{dx} \quad (29)$$

Next we define a dimensionless temperature Θ :

$$\Theta(x^*) \equiv \frac{T(x^*) - T_C}{T_i - T_C}. \quad (30)$$

Substituting in the water mass flow profile, Eqn. (21), and nondimensionalizing gives a linear, homogeneous, first-order ODE:

$$0 = \left[U^* - \left(\frac{C_i - C_C}{C_C}\right) K^* e^{(-K^*x^*)} \right] \Theta(x^*) + \left(\frac{C(x^*)}{C_C}\right) \frac{d\Theta(x^*)}{dx^*}, \quad (31)$$

where the heat transfer NTU is

$$U^* = \frac{UPL}{C_C}, \quad (32)$$

and the heat capacity flow rates are

$$C_i = \dot{m}_a c_{p,a} + m_i \dot{m}_{ma,i} c_{p,w}, \quad (33)$$

$$C_C = \dot{m}_a c_{p,a} + m_C \dot{m}_{ma,i} c_{p,w}, \quad (34)$$

and

$$C(x^*) = C_C + (C_i - C_C) e^{-K^* x^*} \quad (35)$$

Solution of Eqn. (31) gives the dimensionless temperature profile of the moist air along its path through the bubble column:

$$\Theta(x^*) = e^{(-U^* x^*)} \left(\frac{C_i}{C(x^*)} \right)^{\left(\frac{U^*}{K^*} + 1 \right)}. \quad (36)$$

If Eqn. (36) excluded the second righthand term, the temperature profile would be consistent with the profile assumed in the usual derivation of LMTD. However, this term appears for two reasons: the decreasing heat capacity of the moist air stream as water condenses, and the thermal energy left in the moist air stream from water vapor cooling as it diffuses to the bubble surface.

Mean Temperature Difference

The relevant mean temperature difference ΔT is defined as the solution to the equation

$$\dot{Q}_s = -UPL\Delta T. \quad (37)$$

Combining Eqns. (7), (23), (24), (32), (33), (36), and (37) at the air stream exit, $x^* = 1$, leads to an expression for the mean temperature difference, ΔT , which drives heat transfer in the moist air stream of the bubble column dehumidifier:

$$\Theta_o = \left(\frac{C_i}{C_o} \right)^{\left(1 + \frac{C_i - C_o \Theta_o}{C_C} \frac{T_i - T_C}{\Delta T} \frac{\Delta m}{m_i - m_o} \right)} e^{\left(-\frac{C_i - C_o \Theta_o}{C_C} \frac{T_i - T_C}{\Delta T} \right)}, \quad (38)$$

where

$$C_o = \dot{m}_a c_{p,a} + \dot{m}_{w,o} c_{p,w}, \text{ and} \quad (39)$$

$$\Theta_o = \frac{T_o - T_C}{T_i - T_C}. \quad (40)$$

The full solution for ΔT includes the ratio of dimensionless heat and mass transfer coefficients:

$$\Delta T = \frac{(T_i - T_C)(C_i - C_o \Theta_o) / C_C}{\left(1 + \frac{U^*}{K^*} \right) \ln \left(\frac{C_i}{C_o} \right) - \ln(\Theta_o)}. \quad (41)$$

Solving for ΔT without U^* and M^* presents a challenge because it appears in both exponents of Eqn. (38). However, Eqn. (41) can be modified by relating U^* and K^* to the Lewis factor, using the specific heat of the saturated mixture near the bubble surface [7, 15].

$$\frac{U^*}{K^*} = \frac{UPL \dot{m}_{ma,i}}{C_C KPL} \approx \frac{U}{K_{C_p,ma}(T_C)} = Le_f \quad (42)$$

Various Lewis factor correlations based on the Lewis number have been proposed, but Lewis himself found that for air-water mixtures $Le_f \approx 1$ [16]. Therefore, for dehumidifiers condensing water out of air, the first approximation for ΔT is

$$\Delta T_1 = \frac{(T_i - T_C)(C_i - C_o \Theta_o)}{C_C \ln \left(\frac{C_i}{C_o} \right)}. \quad (43)$$

The accuracy can be improved by iterating as follows:

$$\Delta T_n = \frac{(T_i - T_C)(C_i - C_o \Theta_o)}{C_C \left[\left(\frac{C_i - \Theta_o C_o}{C_C} \frac{T_i - T_C}{\Delta T_{n-1}} \frac{\Delta m}{m_i - m_o} + 1 \right) \ln \left(\frac{C_i}{C_o} \right) - \ln(\Theta_o) \right]}. \quad (44)$$

The temperature profiles that lead to the computation of ΔT_{LM} , ΔT_1 , and $\Delta T = \Delta T_\infty$ are plotted in Fig. 5 for a bubble column dehumidifier with typical operating conditions and approximate heat and mass transfer coefficients. The temperature profile implicitly assumed by using the standard LMTD is consistently lower than those which take into account changing heat capacity and mass transfer, leading to approximately a 10% underestimation of the mean temperature difference. The heating due to mass diffusion down a temperature gradient leads to a higher temperature than predicted by LMTD, and the reduction in heat capacity leads to the steeper slope at low values of Θ . The temperature profiles of ΔT_∞ and ΔT_1 are almost indistinguishable, so as long as $Le_f \approx 1$, Eqn. (43) for ΔT_1 can be used to approximate the mean temperature difference, which is presented in dimensional form in Eqn. (45):

$$\Delta T \approx \Delta T_1 = \frac{C_i(T_i - T_C) - C_o(T_o - T_C)}{C_C \ln \left(\frac{C_i^2(T_i - T_C)}{C_o^2(T_o - T_C)} \right)}. \quad (45)$$

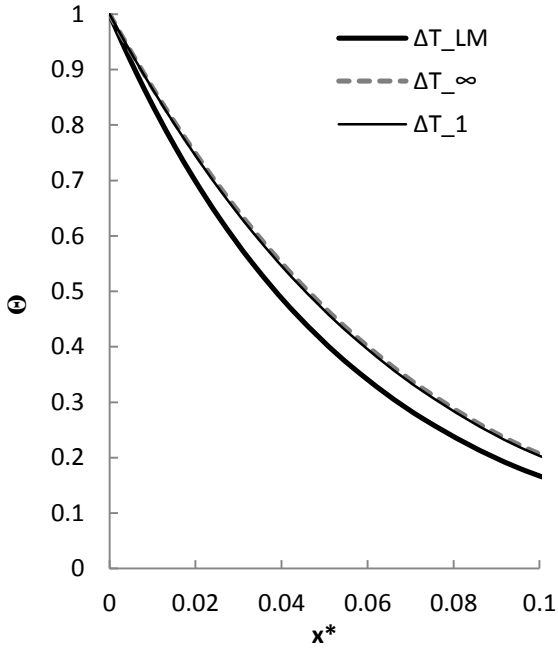

FIGURE 5. DIMENSIONLESS TEMPERATURE PROFILE

This equation can be used to find the mean temperature difference driving sensible heat transfer in the moist air stream of a bubble column dehumidifier or humidifier. Because of the sign conventions used in this work, ΔT will be negative in the case of a humidifier, resulting in positive sensible heat transfer into the humidifying air stream. If the inlet, outlet, and bubble surface heat capacities are set equal, Eqn. (45) reduces to the standard LMTD for a single-stream heat exchanger in which the non-isothermal stream is experiencing a negative heat transfer.

The mean temperature and mass fraction differences are used in the energy balance for a column with steady liquid temperature and no heat loss to the environment:

$$(UA\Delta T_{LM})_{coil} = UPL\Delta T + h_{fg}KPL\Delta m. \quad (46)$$

With the heat and mass transfer coefficients and the definitions of effective length and perimeter, the system consisting of Eqns. (1), (7), (8), (15), (46), and Eqn. (47),

$$\Delta m = \frac{\dot{m}_{ma,i}m_i - \dot{m}_{ma,o}m_o}{KPL}, \quad (47)$$

can be solved for the six unknown quantities: $T_{coil,o}$, $T_{a,o}$, T_C , m_o , m_C , and finally the total heat transfer rate, \dot{Q}_{coil} .

CONCLUSION

A model was developed which treats a bubble column dehumidifier as one single-stream heat exchanger and one single-stream heat and mass exchanger in contact with isothermal column liquid. Algebraic expressions were developed for the mean heat and mass transfer driving forces. The LMTD commonly used to model the mean temperature difference in heat exchangers does not apply to the stream with both heat and mass exchange due to: (a) the changing heat capacity flow rate; and (b) heating of the moist air stream by diffusion of water vapor down a temperature gradient. In the stream with both heat and mass exchange, a log-mean mass fraction difference was shown to be the driving force for mass transfer, and a mean temperature difference was presented which drives sensible heat transfer. With relevant heat and mass transfer coefficients taken from the literature, these simple algebraic expressions can be used to model heat and mass exchange in a bubble column dehumidifier or humidifier.

ACKNOWLEDGMENT

We would like to acknowledge support from the Center for Clean Water and Clean Energy at MIT and KFUPM. The first author would also like to thank the National Science Foundation, the Flowers Family Fellowship, and the Pappalardo Fellowship for partially funding this work.

REFERENCES

- [1] Ettouney, H., 2005. "Design and analysis of humidification dehumidification desalination process". *Desalination*, **183**(1-3), pp. 341 – 352.
- [2] Narayan, G. P., Sharqawy, M. H., Summers, E. K., V, J. H. L., Zubair, S. M., and Antar, M., 2010. "The potential of solar-driven humidification-dehumidification desalination for small-scale decentralized water production". *Renewable and Sustainable Energy Reviews*, **14**(4), pp. 1187 – 1201.
- [3] Narayan, G. P., Sharqawy, M. H., Lam, S., Das, S. K., and Lienhard V, J. H., 2012. "Bubble columns for condensation at high concentrations of non condensable gas: Heat transfer model and experiments". *AIChE Journal*, **Accepted**, pp. n/a–n/a.
- [4] Mills, A. F., 1999. *Heat Transfer*. Prentice Hall.
- [5] Nagle, W. M., 1933. "Mean temperature differences in multipass heat exchangers". *Industrial & Engineering Chemistry*, **25**(6), pp. 604–609.
- [6] Chen, T. D., Conklin, J. C., and Baxter, V. D., 1999. "Dehumidification: Prediction of condensate flow rate for plate-fin tube heat exchangers using the latent j factor". In Proceedings of the ASME/JSME Joint Thermal Engineering Conference, San Diego, CA.

- [7] Mills, A., 2001. *Mass Transfer*. Prentice Hall.
- [8] Tow, E. W., and Lienhard V, J. H., 2013. “Heat flux and effectiveness in bubble column dehumidifiers for HDH desalination”. In Proceedings of the 2013 International Desalination Association World Congress, Tianjin, China.
- [9] Gumerov, N., 1996. “The heat and mass transfer of a vapor bubble with translatory motion at high Nusselt numbers”. *International Journal of Multiphase Flow*, **22**(2), pp. 259 – 272.
- [10] Mendelson, H. D., 1967. “Prediction of bubble terminal velocities from wave theory”. *AIChE Journal*, **13**(2), pp. 250–253.
- [11] Mori, Y., and Nakayama, W., 1965. “Study on forced convective heat transfer in curved pipes: (1st report, laminar region)”. *International Journal of Heat and Mass Transfer*, **8**(1), pp. 67 – 82.
- [12] Mori, Y., and Nakayama, W., 1967. “Study of forced convective heat transfer in curved pipes (2nd report, turbulent region)”. *International Journal of Heat and Mass Transfer*, **10**(1), pp. 37 – 59.
- [13] Akita, K., and Yoshida, F., 1973. “Gas holdup and volumetric mass transfer coefficient in bubble columns: Effects of liquid properties”. *Industrial & Engineering Chemistry Process Design and Development*, **12**(1), pp. 76–80.
- [14] van Krevelen, D. W., and Hoftijzer, P. J., 1950. “Studies of gas-bubble formation calculation of interfacial area in bubble contactors”. *Chemical Engineering Progress*, **46**(1), pp. 29–35.
- [15] Kloppers, J. C., and Kroger, D. G., 2005. “The Lewis factor and its influence on the performance prediction of wet-cooling towers”. *International Journal of Thermal Sciences*, **44**(9), pp. 879 – 884.
- [16] Lewis, W. K., 1922. “The evaporation of a liquid into a gas”. *Mechanical Engineering*, **44**, pp. 445–446.