



Proceedings of the
**International Symposium on
Embedded Systems and Trends in
Teaching Engineering**
Nitra 2016



The Tempus project DesIRE:

**Development of Embedded System Courses with Implementation of Innovative Virtual
Approaches for Integration of Research, Education and Production in UA, Ge, AM**

ORGANIZED BY

Constantine the Philosopher University in Nitra

Faculty of Education

Department of Technology and Information Technologies

This publication is supported by the European Commission within the Tempus project DesIRE no. TEMPUS-project 544091-TEMPUS-1-2013-1-BE-TEMPUS-JPCR “Development of Embedded System Courses with Implementation of Innovative Virtual Approaches for Integration of Research, Education and Production in UA, Ge, AM”.

Embedded Systems and Trends in Teaching Engineering

Editors: prof. Ing. Tomáš Kozík, DrSc.,
Mgr. Miroslav Šebo, PhD.,
doc. PhDr. Zdena Kráľová, PhD.,

Reviewers: See list inside Proceedings

Layout: prof. Ing. Tomáš Kozík, DrSc.,
Graphic design: Mgr. Peter Kuna, PhD., Mgr. Miroslav Šebo, PhD.,
Cover design: Mgr. Miroslav Šebo, PhD., prof. Ing. Tomáš Kozík, DrSc.,

The publication did not pass the language edition review of the publishing house. The authors of individual papers are responsible for technical, content and linguistic correctness.

Published: Faculty of Education of the Constantine the Philosopher University in Nitra

Dražovská cesta 4, 949 74 Nitra, Slovakia

Printed: Garmond Nitra

Unauthorized use of the work is a breach of copyright and may be subject to civil, administrative or criminal liability

First edition Nitra 2016

© Constantine the Philosopher University in Nitra, Faculty of Education, 2016

ISBN 978-80- 558-1041-6

SECTION 3 - EDUCATION AND TRAINING

Implementation of "Embedded Systems" Disciplines in Computer Science Students Training

Vadym Abramov, Oksana Lytvyn

*Chair of Information Technologies and Mathematic Disciplines, Borys Grinchenko Kyiv
University, Kyiv (UKRAINE)*

v.abramov@kubg.edu.ua; o.lytvyn@kubg.edu.ua

Abstract

This article describes an approach to teaching of embedded systems (ES) disciplines for non-engineering students using original technique to study embedded systems design, realization and testing. The approach to be effective for implementation in a classical university and include all modern ES technologies. To create the teaching technique most of existing technologies were analysed, compared and adapted to be convenient for training. Teaching technique for the cycle of "Embedded Systems" disciplines includes traditional, virtual and remote design technologies. The example of completed student project described where "smart home" prototype was made.

Keywords: embedded system, teaching, technology, project activities

1 INTRODUCTION

Today the scope of ES is constantly expanding, they are widely used in consumer electronics, industrial automation, transportation, telecommunication, medical equipment, aerospace technologies and other areas. These systems will be imbued in all spheres of human activity soon. But a variety of automation tasks and solutions creates a huge number of options for ES implementation. It is a complex scientific and technical task for developer to make an optimal choice, taking into account various physical, technical and financial conditions and restrictions. Therefore, the developer is very important to be clear about the subject of design, the possible and available modern methods and means of its creating, to be able to choose or create a similar prototype, combine the knowledge of both hardware and software parts of the future product [1,2].

Therefore, one of the objectives of the "Embedded Systems" study is to familiarize students with the widest possible list of design tools and so-called semi-finished products (computing modules, libraries, peripherals, etc.) at every stage of embedded system development. Students should gain experience using them, and performing comparative analysis and conclusions on the use of each of the approaches in a particular task. In addition, since the actual specialized embedded systems may contain a ready-made and original solutions in different proportions, students must learn the main template solutions of basic problems and their possible modifications.

But taking into account the growing complexity of embedded systems and methods as well as means of implementation, the existing educational and methodical ways and means require review and renewal to perform the described task [3]. The purpose of the presented work was to develop training technique for embedded computer systems designing suitable for its implementation by students at the studding of relevant courses and creating of their own projects.

2 TEACHING TECHNIQUE FOR DEVELOPMENT OF EMBEDDED SYSTEM

Each developer of a real embedded system uses a limited number of their favorite or most effective methods in its field of design for simulation and debugging of hardware and software. The method also depends on the type of component base used, purpose of ES, the scope, technical and other requirements.

These production methods are not suitable for studding because they are very specialized, designed for a specific production process, production equipment, use some traditional microcontrollers and electronic components. Training techniques should provide students with basic tools at every stage of ES development. Students will take knowledge and experience of their application as well as the ability of independent comparative analysis of different approaches and selecting the most appropriate tool.

We have developed a training technique of ES designing for students of non-engineering specialty. The technique characterized by simplified, most popular and non-expensive technologies and features of their applications. The stages of training technique shown in Table 1.

Table 1: Main stages of training technique for embedded systems designing

| Stage | Contents of stage | The task for the student | The result of student learning |
|---|---|--|---|
| Preparation of technical specifications | <ul style="list-style-type: none"> - a detailed description of developed device functions and tasks by ordinary language - preparation of specification using terms of the relevant subject area | <ul style="list-style-type: none"> - study the art of active communication with the customer which is not always understand what they need and how to do it - introduction with concept of the specification - formulate goals and objectives of the device - study of domestic and international experience on the subject of project | <ul style="list-style-type: none"> - the ability to negotiate with the customer, - understanding of the contents and rules of a technical specification preparation - willingness to study scientific and technical information. |
| Block diagram preparation | <ul style="list-style-type: none"> - the transformation of functions and tasks described in specification into, the blocks of device, - designing of consolidated functional algorithm of device and microcontroller. | <ul style="list-style-type: none"> - implement device functions by standard or typical block or blocks of own design. | <ul style="list-style-type: none"> - ability to perform design of parts and assemblies in accordance with the terms of specification using both the standard design automation software and self-created original applications; |
| Designing of schematic diagram | <ul style="list-style-type: none"> - detailed elaboration of all functional blocks, - clarification of algorithm details - preliminary selection of microcontroller and components | <ul style="list-style-type: none"> - to study the structure and functions of microcontroller and external electronic circuitry, logic circuits, converters, display devices, sensors, executing devices and others. | <ul style="list-style-type: none"> - understanding of operation of all system elements and their management, - understanding of electronic circuit operation |
| Selecting IDE | <ul style="list-style-type: none"> - choice of programming languages, debugging techniques and hardware platform for physical modelling | <ul style="list-style-type: none"> - familiarization with the basic software (Arduino IDE, Atmel Studio, Code Vision, Quartus II, Proteus Design, Altium Designer), their capabilities and limitations, - selection of appropriate for the task | <ul style="list-style-type: none"> - knowledge of basic products for the ES designing and their functions - the ability to compare, analyse and choose the right tool |
| Coding of software | <ul style="list-style-type: none"> - coding, compiling and debugging of software. | <ul style="list-style-type: none"> - create a software for a particular task, - correction of errors | <ul style="list-style-type: none"> - programming skills using word processing environment, - ability to find and fix syntax and logic errors in code. |
| Simulation of project | <ul style="list-style-type: none"> - simulation of project with viewing and editing variables, code tracing, step by step code execution, - simulation with the external electronic circuit signals simulation | <ul style="list-style-type: none"> - familiarization with the principles of software simulation in different software, - simulation of the own project in chosen IDE, - simulation of microcontroller and external electronic circuit (in Proteus, Quartus II virtual on-line simulator Autodesk 123D) | <ul style="list-style-type: none"> - skills of created code testing by different means |

| | | | |
|--|--|---|---|
| Creating of a physical model of device | <ul style="list-style-type: none"> - construction of the physical layout of the device according to specification and schemes created on previous stages - uploading(firmware) of program in memory of the microcontroller, - hardware and software setup of the device | <ul style="list-style-type: none"> - make a layout - upload code via programmer - perform system debugging | <ul style="list-style-type: none"> - skills and experience of electronic circuits designing and work with interfaces and memory. |
| Production and adjustment of device | <ul style="list-style-type: none"> - development and production of printed circuit boards and assembly of finished devices - adjustment of created device for assembling defects, bad contacts, short circuits, faulty parts, electro-magnetic interference, etc. | <ul style="list-style-type: none"> - familiarity with printed circuit board development tools (Proteus, Fritzing), - Test hardware of device using a logic analyser | <ul style="list-style-type: none"> - understanding of the full production cycle of electronic equipment - ability to analyse the functioning of electronic circuit and diagnose it condition. |
| presentation of project | <ul style="list-style-type: none"> - presentation of fulfilled work for teacher and friends. | <ul style="list-style-type: none"> - Analysis of fulfilled work - Analysis of mistakes and achievements - preparation of presentation | <ul style="list-style-type: none"> - analysis skills of own activities, including errors - presentation skills of own work |

The main part of the methodology tested in practice during classes with students within disciplines "Physical processes in computer systems" and "Technology of Embedded Computer Systems", which were implemented in the 2015-2016 academic year. It was found that most problems arise when students modelling hardware in simulations including external electronic circuits and devices, as well as under adjustments of physical models and real physical devices. This is definitely the most difficult sections of the technique and the most expansive, so they should be given more attention. For example, the difficulties appear at working with simulator consisting of integrated platforms for modelling of external influences on microcontroller. Quite complex and expensive are devices for in-circuit debugging of hardware and software parts.

It is advisable to use Arduino platform [4] for simple and quick transition of students from programming to effective development of real projects. Having knowledge and skills in C programming, computer science students easily construct their own devices, which increases interest and initiative in creating their own product. The good point is that almost every sensor or module already tested by user community that enables students in a short time allocated to discipline, to get significant results. However, simplifying the process of creating embedded system platform through the use of Arduino, it is necessary to stress this point. Students must understand the depth and diversity of the developing process out of Arduino.

It should be noted that the establishment of a physical model is the most difficult stage to understand and requires expensive equipment and completely it is not always possible to do. Therefore, during training sometimes it makes sense to carry only the virtual design stage, such as using the GOLDi remote virtual lab [5, 6]. Students can remotely perform all phases of design and observe the operation of ES on a virtual and real physical object.

3 STUDENT PROJECT

During studding the "Technology Embedded Computer Systems" discipline students developed working model of "smart home". The model consists of hardware and software for monitoring, control and remote management via mobile device. The model includes a local control panel; remote management via mobile phone / tablet through the Internet; intelligent algorithms for decision-making based on custom settings and monitoring results; fire safety systems, monitoring of emergencies and security with appropriate notification about incidents through Internet to defined addressee.

The hardware component of the system, and monitoring and managing developed using Arduino platform and Blynk cloud service [7].

Blynk cloud service allows bidirectional data transfer and provides graphical interface (GUI) for remote control of microcomputers and microcontrollers, including Arduino and Raspberry Pi. Information collected from sensors and microprocessor and connected devices controlled through GUI. GUI has a great set of "gadgets" for control and visualization: switches, sliders, LEDs, displays. Each of them has its own logic and could be customized for data logging and visualization from corresponding sensors as well as for control data transmission.

Hardware and software Arduino platform selected due to availability, convenience and ease of programming language, open architecture and code, and a wide range of electronic devices of various types, including network adapters. The basis of the project is a microcontroller board Arduino Mega, connect to the Internet by ESP8266 Wi-Fi module. Popular sensors used for temperature and humidity measurements (Dallas DS18B20, DHT11) as well as an infrared motion sensor, photoresistors, servo driver motors, LEDs, relays and other components. Project designed in the Fritzing package [8], software sketch written in standard Arduino integrated development environment.

Key elements of the "smart home" monitoring and control, used in the project is shown in Figure 1. Circuit connection of the ESP8266 Wi-Fi module and LCD display of local control panel shown in Fig.2.

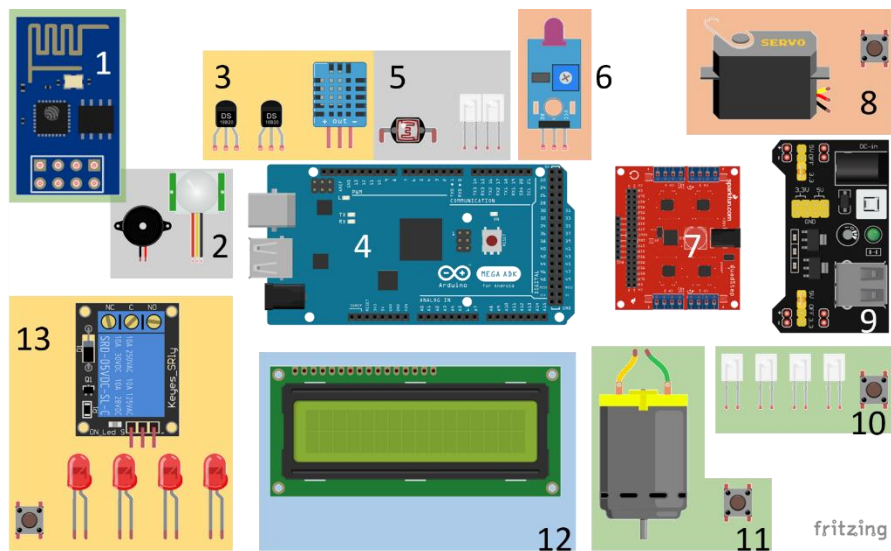

Figure 1: The components of "smart home" prototype: Wi-Fi Internet connection module (1), motion sensor and siren (2), temperature sensors, light and flame sensors (3,5,6), microprocessor board Arduino Mega (4) driver (7), air conditioning (11) and light (10), servo drive for garage door (8) power supply 3.3 and 5V (9), LCD display of local control panel (12), relay for heating control (13).

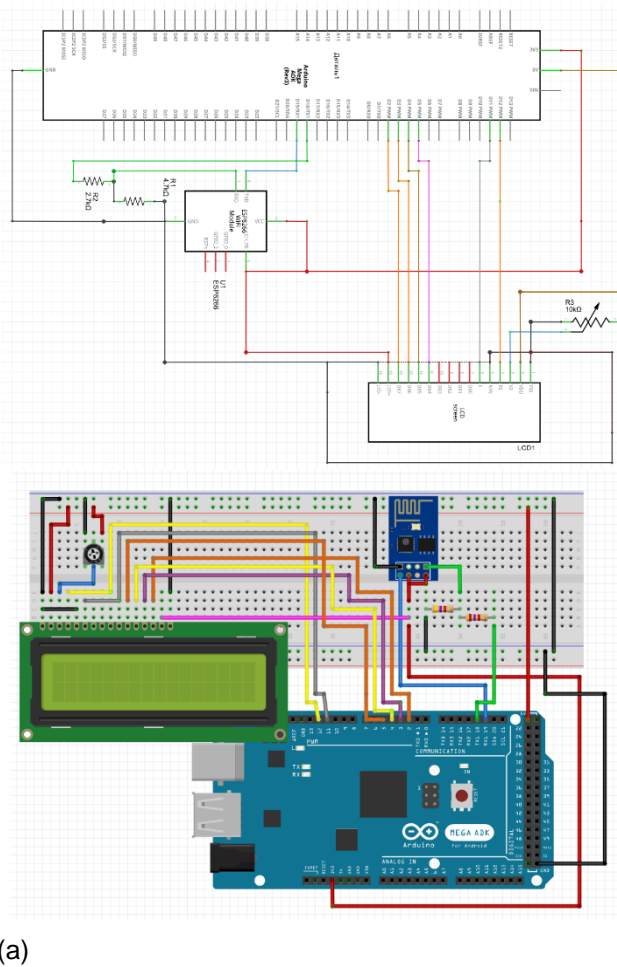

Figure 2: Schematic diagram (a) and circuit assembly (b) LCD display and ESP8266 Wi-Fi module.

The developed prototype of monitoring and control system for "smart home" based on Blynk cloud service and Arduino platform has a very high ratio of functionality / cost / complexity of implementation (Figure 3). The chosen modular approach allows further expansion of functionality (for example, "solar power", entertainment, automatic watering of plants etc.).

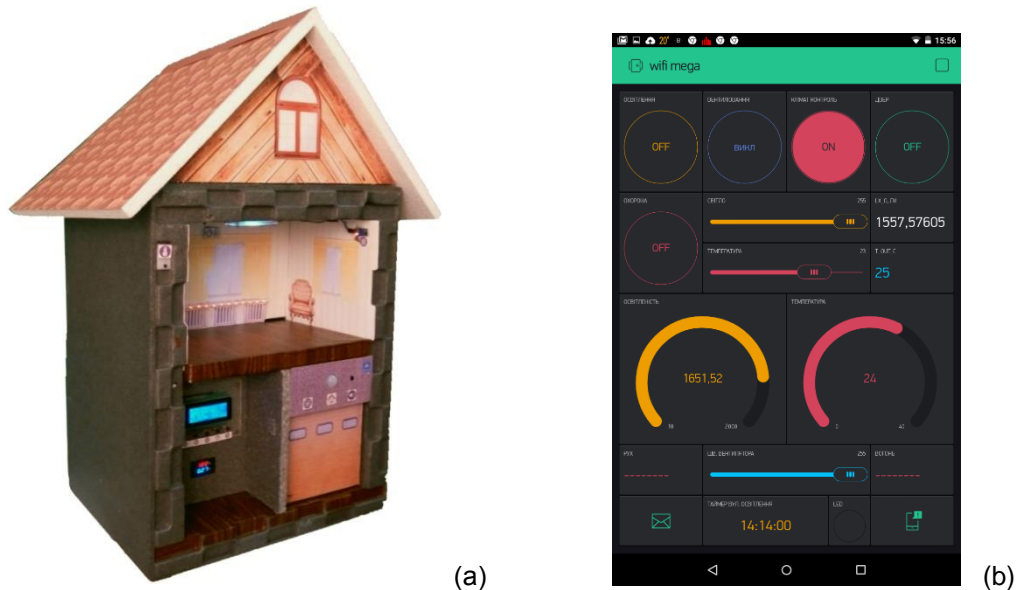

Figure 3: Model of “smart home” with built-in monitoring and management (a), the GUI (b).

4 CONCLUSIONS

In today's dynamic environment of methods, techniques, tools and technologies for embedded systems the main objective of the study is how to provide basic knowledge and skills in designing, and train students to work independently and learn to adapt to the constantly changing field of embedded systems. Despite the fact that in the described training technique we pay less attention to physical and technical aspects, it covers all stages of developing used in production, and achieves a stated goal: to develop the students' abilities and skills of designing technologies and assess the impact of software and hardware on the functionality and reliability of the device being developed.

The complexity of the subject of study predetermines implementation of the “project approach” to learning, which is used over several years and covers various disciplines. In addition, individual tasks in the developing project stimulate the most effective work of each student at all stages of project performance.

Acknowledgements

This work is also supported by the project "DesIRE - Development of Embedded System Courses with implementation of Innovative Virtual approaches for integration of Research, Education and Production in UA, GE, AM" by the European Commission within the program "Tempus", Grant No 544091-TEMPUS-1-2013-1-BE-TEMPUS -JPCR [9].

References

- [1] Field, K.: 10 skills embedded engineers need now. Available: <http://www.embedded.com/electronics-news/4438618/10-skills-embedded-engineers-need-now>
- [2] Kuz`min SA, Sinitsyn SV, etc: Configuration management for teaching designing embedded software (in rus.). In: XIII All-Russian conference "Teaching of information technology in the Russian Federation": Perm State National Research University, Perm, Russia, 2015. Available: <http://edu.evnts.pw/materials/141/18861/>
- [3] Büchner, S.: Teaching Embedded Systems in Higher Education by Visualizing Component Relations. In: X World Conference on Computers in Education, Vol. 1: Research Papers, pp. 92-100. Nicolaus Copernicus University Press, Torun, Poland, 2013. ISBN 978-83-231-3090-1
- [4] Arduino Website: <https://www.arduino.cc/>
- [5] Henke K., Ostendorff St., Wuttke H.-D., Vietzke T., Lutze Ch.: Fields of Applications for Hybrid Online Labs. In: International Journal of Online Engineering, Vol 9, 2013, pp. 20-30. ISSN: 1861-2121.
- [6] The Grid of Online Laboratory Devices Ilmenau (GOLDi) Website: <http://www.goldi-labs.net>

- [7] Blynk Website: <http://www.blynk.cc/>
- [8] Fritzing Website: <http://fritzing.org/>
- [9] DesIRE project Website: <http://tempus-desire.eu/>