

**Risk-based shutdown  
inspection and maintenance  
for a processing facility**

By

Abdul Hameed

A thesis submitted to the School of Graduate Studies  
in partial fulfillment of the requirements for the degree of

**Doctor of Philosophy**

Faculty of Engineering and Applied Science

Memorial University of Newfoundland

**October - 2016**

St. John's, Newfoundland

## **Abstract**

In this research, a risk-based shutdown inspection and maintenance interval optimization for a processing facility is proposed. Often inspection and maintenance activities can't be performed until the processing unit or plant is taken into a non-operational state, generally known as "shutdown". Extensive work on inspection and maintenance interval estimation modeling is available in the concerned literature however, no to very limited application on shutdown inspection and maintenance modeling is observed for a continuous operating facility. Majority of the published literature deals to optimize individual equipment inspection and maintenance interval without considering the overall impact of plant unavailability due to shutdown. They all deal to optimize individual equipment inspection and maintenance interval considering cost, risk, availability and reliability. The efforts towards finding an optimal inspection and maintenance interval is not considered in these studies especially when it requires unit or plant to be in shutdown state from an operational state for performing inspection and maintenance. This topic is selected to bridge the existing gap in the available literature and to provide a means to develop a methodology to estimate the shutdown inspection and maintenance interval for a continuous processing unit or plant, rather an inspection and maintenance interval for each piece of equipment considering the overall asset availability, reliability and risk.

A component failure due to wear or degradation is a major threat to asset failure in a processing facility. A carefully planned inspection and maintenance strategy not only mitigate the effects of age-based degradation and reduce the threat of failure but also minimize the risk exposure. Generally failure caused by wear or degradation is modeled as a

stochastic process. For an effective inspection and maintenance strategy, the stochastic nature of failure has to be taken into consideration. The proposed methodology aims to minimize the risk of exposure considering effect of failure on human life, financial investment and environment by optimizing the interval of process unit shutdown. Risk-based shutdown inspection and maintenance optimization quantifies the risk to which individual equipment are subjected and uses this as a basis for the optimization of a shutdown inspection and maintenance strategy.

**Keywords:** Risk-based, Availability, Reliability, Safety, Failure consequences, Shutdown, Maintenance Scheduling Optimization, Genetic Algorithms

**This dissertation is dedicated to my parents**

*Muhammad Alamgeer and Salma Khatoon*

*My wife*

*Shaista Hameed*

*&*

*My kids*

*Nabiha Hameed, Rayyan Hameed and Fayzan Hameed*

*for their endless love and support ...*

## **Acknowledgments**

First and foremost, all praises to Allah, the most Gracious and Most Merciful, for giving me the opportunity and strength to complete this work. I am pleased to acknowledge several individuals for their guidance, contribution and support throughout my Ph.D. program.

I would like to thank my academic advisor, Dr. Faisal Khan for giving me the opportunity to work with him on this research. Without his guidance, support and encouragement throughout this program, this dissertation would have been impossible. Dr. Khan has been supportive in all circumstances whether academically, professionally and personally.

I would also like to thank my supervisory team members, Dr. Salim Ahmed for providing valuable guidance and help throughout the study and Dr. Syed Imtiaz for his guidance and support in completing this dissertation.

I would like to offer thanks to my friends, Dr. Syed Asif Raza and Dr. Qadeer Ahmed, for their support and guidance to address industry problems.

I am indebted to the graduate studies department of Memorial University for providing me with such a great opportunity. I am sincerely thankful to all who helped me, including the administrative, technical and academic staff at Memorial University.

Most especially, I would like to thank my parents, brothers and sisters for providing me support and encouragement in growing and securing an outstanding education. I could not have completed this without their love, support and generosity.

Last but not least, I would like to take this opportunity to thank my wife and beloved kids for their unselfish support for their understanding, patience and sacrifices during my study.

## Co-Authorship Statement

I, Abdul Hameed, hold a primary author status for all the chapters in this dissertation. However, each manuscript is co-authored by my supervisor and co-researchers. Supports from my friends and colleagues were also obtained in facilitating the development of this work as described below.

- **Hameed A., & Khan, F. (2014). A framework to estimate the risk-based shutdown interval for a processing plant. Journal of Loss Prevention in the Process Industries, 32, 18–29.**

*Statement: I am the primary author and carried out numerical modeling and analysis. I have drafted the manuscript and included all the comments after review from co-author in the final manuscript. As co-author, Faisal I. Khan helped in developing the idea, reviewed, corrected the model and results. He also contributed in reviewing and revising the manuscript.*

- **Hameed, A., Khan, F., & Ahmed, S. (2015). A risk-based methodology to estimate shutdown interval considering system availability. Process Safety Progress, 34 (3), 267-279.**

*Statement: In primary author capacity, I developed the framework and implemented analyzed and compiled the results. I have drafted the initial manuscript which was reviewed and commented by co-authors. Their suggestions were later incorporated in the final manuscript. As co-author, Faisal I. Khan guided for the improvements of overall framework and supported in finalizing the methodology to implement the*

*framework. He also contributed in reviewing and revising the manuscript. As co-author, Salim Ahmed contributed in reviewing and revising the manuscript.*

- **Hameed, A., Khan, F., & Ahmed, S. (2016). A Risk-based Shutdown Inspection and Maintenance Interval considering human error for a processing facility. Process Safety and Environmental Protection, 100, 9-21.**

*Statement: In primary author capacity, I developed the framework and implemented analyzed and compiled the results. I have drafted the initial manuscript which was reviewed and commented by co-authors. Their suggestions were later incorporated in the final manuscript. As co-author, Faisal I. Khan guided for the improvements of overall framework and supported in finalizing the methodology to implement the framework. He also contributed in reviewing and revising the manuscript. As co-author, Salim Ahmed contributed in reviewing and revising the manuscript.*

- **Hameed, A., Raza, S.A., Ahmed, Q., Khan, F.I., & Ahmed, S. (2016). Risk-based maintenance scheduling for a LNG gas sweetening unit. Submitted in Journal of Loss Prevention in the Process Industries.**

*Statement: As a primary author, I developed and integrated the concept of maintenance scheduling considering shutdown application. I have drafted the manuscript for review and comments, later, included all the comments from co-authors in the final manuscript. As a co-author, Syed A. Raza participated in the development of the Genetic Algorithm code in MATLAB. He also contributed in reviewing and revising the manuscript. As co-author, Qadeer Ahmed contributed in*



*developing and refining the idea and providing data support, reviewed, and feedback on the model and results. He also contributed in reviewing and suggesting areas to improve the manuscript. As co-author, Faisal I. Khan guided for the improvements of overall framework and supported in finalizing the methodology to implement the framework. He also contributed in reviewing and revising the manuscript. As co-author, Salim Ahmed contributed in reviewing and revising the manuscript.*

Abdul Hameed

## Table of Contents

Abstract.....	ii
Acknowledgments.....	v
Co-Authorship Statement .....	vii
Table of Contents .....	x
Table of Figures .....	xiii
List of Tables .....	xvi
List of Symbols & Abbreviations .....	xvii
1 CHAPTER 1 – Introduction and Overview .....	1
1.1 Introduction .....	1
1.2 Research Objective and Scope .....	2
1.3 General Terminology and Definitions .....	5
1.4 Constraints and Limitations .....	15
1.5 Thesis Structure .....	16
2 CHAPTER 2 – A framework to estimate the risk-based shutdown interval for a processing plant.....	19
2.1 Introduction .....	20
2.2 State-of-the-art on shutdown inspection and maintenance: .....	22
2.3 Risk-based shutdown inspection and maintenance interval (RBSIM) methodology ..	27
2.4 The application of RBSIM to an onshore processing facility unit .....	41
2.5 Results & discussions .....	42
2.6 Summary and Conclusions.....	48

3	CHAPTER 3 – A risk-based methodology to estimate shutdown interval considering system availability.....	51
3.1	Introduction .....	52
3.2	A risk-based Shutdown Interval Methodology (RBSIM).....	57
3.3	The Application of RBSIM to a LNG Processing Facility .....	77
3.4	Discussion and Conclusions.....	88
4	Chapter 4 – A risk-based shutdown inspection and maintenance interval considering human error for a processing facility .....	91
4.1	Introduction .....	92
4.2	Past Studies .....	94
4.3	A risk-based inspection and maintenance modeling considering human error.....	99
4.4	The application of RBSIM to a LNG processing facility .....	116
4.5	Conclusion.....	127
5	Chapter 5 – Risk-based maintenance scheduling for a LNG gas sweetening unit.....	129
5.1	Introduction .....	130
5.2	Literature Research.....	132
5.3	LNG Gas Sweetening Unit.....	136
5.4	Risk-based Bi-Objective Maintenance Scheduling Model .....	140
5.5	Operational Risk-based Equipment Selection:.....	144
5.6	Bi-objective model formulation .....	150
5.7	Simulation Study .....	162
5.8	Conclusions .....	169
6	Chapter6 – Conclusion, Contribution and Future work .....	171

6.1	Introduction .....	171
6.2	Research Contributions .....	172
6.3	Conclusion.....	176
6.4	Recommendations for Future Research Work .....	177
7	REFERENCES.....	180
7.1	References - Chapter 1.....	180
7.2	References - Chapter 2.....	181
7.3	References - Chapter 3.....	185
7.4	References - Chapter 4.....	190
7.5	References - Chapter 5.....	197
7.6	References - Chapter 6.....	203

## Table of Figures

Figure 1-1: Overall research strategy .....	5
Figure 1-2: Types of maintenance.....	8
Figure 1-3: Failure consequence modeling.....	13
Figure 1-4: Asset Failure Scenarios and Hazards .....	14
Figure 2-1: Frame work to estimate risk-based shutdown interval.....	29
Figure 2-2: Qualitative Criticality risk ranking matrix .....	30
Figure 2-3: Block diagram showing equipment acting in series.....	31
Figure 2-4: Block diagram showing equipment acting in series/parallel configuration .....	31
Figure 2-5: Process flow schematic of a gas chilling/liquefaction unit .....	42
Figure 2-6: Block diagram of the critical equipment selected for a gas chilling/liquefaction unit.....	43
Figure 2-7: Risk-based shutdown maintenance & inspection interval.....	48
Figure 3-1: Shutdown Classification.....	54
Figure 3-2: Risk-based shutdown interval methodology.....	59
Figure 3-3: Qualitative criticality risk ranking matrix .....	61
Figure 3-4: Operational and shutdown state of a repairable system .....	63
Figure 3-5: Markov state space diagram of a single component repairable system .....	63
Figure 3-6: Illustration of failure patterns (redrawn after Nowlan and Heap, 1978).....	64
Figure 3-7: State space diagram of an unplanned and planned shutdown for system with redundancy.....	67
Figure 3-8: State space diagram of an unplanned and planned shutdown for system with no redundancy.....	68

Figure 3-9: Air Products AP-X™ process (redrawn after Roberts et al. 2002).....	79
Figure 3-10: Block diagram of critical selected equipment for MR unit .....	82
Figure 3-11: Risk-based shutdown inspection and maintenance interval modeling .....	86
Figure 3-12: Risk-based shutdown inspection and maintenance interval - Sensitivity analysis for availability .....	87
Figure 3-13: Risk-based shutdown inspection and maintenance interval - Sensitivity analysis for MSDT.....	88
Figure 4-1: A Risk based inspection and maintenance interval optimization model considering human error .....	101
Figure 4-2: Qualitative Criticality risk ranking matrix .....	104
Figure 4-3: System Operational Availability .....	107
Figure 4-4: SLIM methodology to calculate HEP .....	109
Figure 4-5: Impact of Human Error in Survival Function.....	111
Figure 4-6: A typical LNG processing plant process flow .....	117
Figure 4-7: Gas Chilling and Liquefaction Unit .....	119
Figure 4-8 Functional block diagram of selected equipment .....	120
Figure 4-9: Risk-based shutdown inspection and maintenance .....	126
Figure 4-10: Risk-based shutdown inspection and maintenance .....	127
Figure 5-1: A typical LNG Process Plant (Mokhatab, Mark, Valappil, & Wood, 2014) .....	137
Figure 5-2: A typical Section of gas sweetening unit .....	138
Figure 5-3: Operational Risk-based Equipment Selection .....	146
Figure 5-4: Proposed solution framework .....	154
Figure 5-5: Decision Variable re-orientation.....	155

Figure 5-6: Population representation in a typical generation ..... 161

Figure 5-7: Pareto Front - Total Maintenance Cost Subject to Reliability Constraints ..... 167

## List of Tables

Table 2.5-1: Critical equipment selected from gas chilling and liquefaction unit .....	43
Table 2.5-2: The failure rate data for the equipment considered in this case study .....	44
Table 2.5-3: Failure scenarios and their estimated consequences.....	46
Table 3-1: Five levels of probability of failure .....	61
Table 3-2: Five level consequence table.....	62
Table 3-3: Critical selected equipment for MR unit.....	81
Table 3-4: Critical selected equipment failure and repair data .....	83
Table 3-5: Estimated system failure and repair rates .....	83
Table 4-1: Five Level of Probability of failure (Khan et al. (2014)).....	104
Table 4-2: Five Level Consequence Table (Khan et al. (2014)).....	105
Table 4-3: Consequence Estimation (Khan et al. (2014)) .....	114
Table 4-4: The failure Characteristics of considered equipment. ....	120
Table 4-5: List of considered PSF.....	121
Table 4-6 : Performance Shaping Factor, Rank and Weight .....	122
Table 4-7: Common Shutdown Inspection and Maintenance activities and estimated HEP. ....	123
Table 4-8: Estimated failure consequences .....	125
Table 4-9: Estimated Shutdown Cumulative time .....	126
Table 5-1: MATLAB (2015b) built-in procedure ‘ga’ related selected parameters in ‘gaoptimset’ .	159
Table 5-2: MATLAB (2015b) built-in procedure ‘ga’ user-defined functions and parameters .....	160
Table 5-3: Operational Riskbased Equipment Selection .....	163
Table 5-4: Failure Data.....	164
Table 5-5: Inspection and Maintenance Cost Data .....	165
Table 5-6: Inspection and Maintenance Schedule for Target Reliability of 90% .....	168
Table 5-7: Inspection and Maintenance Schedule for Target Reliability of 95% .....	168



## List of Symbols & Abbreviations

<b>Symbol/ Abbreviation</b>	<b>Description</b>
<i>ABAO</i>	As bad as old
<i>AD</i>	Asset density
<i>AGAN</i>	As good as new
<i>ALARP</i>	As low as reasonably practicable
<i>APCI</i>	Air Products and chemicals inc.
<i>API</i>	American petroleum institute
<i>BLEVE</i>	Boiling liquid expanding vapor explosion
<i>CBM</i>	Condition based maintenance
<i>CF</i>	Cost of injury and fatality
<i>CM</i>	Corrective maintenance
<i>DOD</i>	Department of defense, USA
<i>FAA</i>	Federal aviation authority
<i>ECAL</i>	Economic consequence of asset loss
<i>ECF</i>	Economic consequence of failure
<i>ECHHL</i>	Economic consequence of human health loss
<i>ECPL</i>	Economic consequence of production loss cost
<i>ECSIM</i>	Economic consequence of shutdown inspection and maintenance
$EC_T$	Total economic consequence
<i>EZ</i>	Effected zone due to overpressure

<i>HEART</i>	Human error assessment and reduction technique
<i>HEP<sub>k</sub></i>	Human error probability of task k
<i>HP</i>	High Pressure
<i>HSE</i>	Health, safety and environment
<i>IAEA</i>	International atomic energy agency
<i>JHEDI</i>	Justified human error data information
<i>LLP</i>	Low low pressure
<i>LNG</i>	Liquefied natural gas
<i>LP</i>	Low pressure
<i>MCHE</i>	Main cryogenic heat exchanger
<i>MR</i>	Mixed refrigerant
<i>MSDT</i>	Mean shutdown time
<i>MTTR</i>	Mean time to repair
<i>MP</i>	Medium pressure
<i>NG</i>	Natural gas
<i>OEM</i>	Original equipment manufacturer
<i>OREDA</i>	Offshore and onshore reliability data
<i>PD</i>	Population density
<i>PDHF</i>	Probability of damage due to heat flux
<i>PDOP</i>	Probability of damage due to overpressure
<i>PERD</i>	Process equipment reliability database
<i>PIHF</i>	Probability of injury or death due to heat flux

<i>PL</i>	Production loss volume per day
<i>PM</i>	Preventive maintenance
<i>POF</i>	Probability of failure
<i>PSF</i>	Performance shaping factor
<i>RBD</i>	Reliability block diagram
<i>RBM</i>	Risk-based maintenance
<i>RBI&amp;M</i>	Risk-based inspection and maintenance
<i>RBSIM</i>	Risk-based shutdown inspection and maintenance
<i>SDT</i>	Shutdown time in days
<i>SLIM</i>	Success likelihood indexing method
<i>SP</i>	Selling price of product per unit volume (\$/Unit)
<i>THERP</i>	Technique for human error rate production
<i>VCE</i>	Vapor cloud explosion
<i>A</i>	System availability
$C_i$	Inspection Cost (\$)
$C_{ie}$	Cost of inspection equipment (\$/Hr.)
$C_{li}$	Cost of inspection labor (\$/Hr.)
$C_{lm}$	Cost of skilled maintenance labor (\$/Hr.)
$C_{lp}$	Cost of preparatory maintenance labor (\$/Hr.)
$C_{lts}$	Cost of technical labor (\$/Hr.)
$C_m$	Maintenance cost (\$)
$C_p$	Preparatory cost (\$)

$C_{sp}$	Cost of spare parts (\$)
$C_{ts}$	Technical support cost
$d$	Operational state with duration
$EC_T$	Total economic consequence
$f_i$	Expected number of failures of the $i$ th unique subsystem over the system design life
$F_{sys}(t)$	System failure probability at time $t$
$MTTR_i$	Mean time to repair the $i$ th unique subsystem
$MTTR_{sys}$	System mean time to repair
$P_i$	Probability of being in state $i$
$P_j$	Probability of being in state $j$
$p(t)$	Probability of a complete repair
$PL$	Production loss volume per day
$PL_c$	Cost of production loss
$Q$	System unavailability
$q_i$	Number of identical subsystem of type $i$
$q(t)$	Probability of minimal repair
$R_{sys}(t)$	System reliability at time $t$
$RISK_e$	Estimated risk (\$)
$SP$	Selling price of product volume per day
$t$	Operating time (h)
$t_d$	Design life of the plant or unit

$t_i$	Duration of inspection work
$t_m$	Duration of maintenance work
$t_p$	Duration of preparatory work
$t_{ts}$	Duration of technical support work
$T_{SD}$	Shutdown interval
$\beta$	Weibull Shape Parameter
$\theta$	Weibull Characteristic life
$\lambda(t)$	Weibull Hazard rate
$\lambda_{pc}$	Failure rate for parallel configuration
$\lambda_{sc}$	Failure rate for series configuration
$\lambda_{sys}(t)$	System failure rate
$\lambda$	Exponential failure rate
$\mu$	Exponential repair rate

# **CHAPTER 1**

## **Introduction and Overview**

### **1.1 Introduction**

Processing industries such as oil and gas and petrochemicals are considered to be complex industries due to their size and production volumes. A process plant consists of equipment, machineries, systems or their integral parts or components (hard resources; such as pipes, heat exchangers, electric motors, pumps, turbine, vessel, columns, flow and control valves etc. etc.), controlling and monitoring software (soft resources) which provide a specific function or services. These hard and soft resources are generally called physical assets. These physical assets are a combination of many permanent or temporary components which are configured within the hierarchy of an asset. Performance of these assets depends on their reliability, operation and maintainability. Very often these components need to be removed, repaired, overhauled or replaced in order for the asset to keep functioning or deliver the output it is designed for. When an asset fail (partial or total) to perform its intended function, it may result in loss of production, poor quality products, financial losses and in some case, serious hazardous and environmental issues. These failures or breakdowns could be due to cracks, leakages, corrosion, erosion, heating, vibration and wear (age related). Failure to detect these symptoms and not inspecting or reacting to remove these

degraded mode or functionality may result in major asset breakdowns or serious catastrophic failures.

A set of activities or actions which ensures that the asset is available to perform its intended function, in a cost effective manner is generally called maintenance. Proper and effective inspection and maintenance of the asset not only helps to sustain the reliability of its functioning but also to improve its availability and performance as required. Best inspection and maintenance strategy helps to detect the potential failure before it produce undesired event or down time e.g. emergency shutdown for corrective action. Gulati and Smith (2009) reported that maintenance is an act of maintaining, or the work of keeping an asset in proper operating condition. It may consist of performing maintenance inspection and repair to keep assets operating in a safe manner to produce or provide designed capabilities. These actions can be Preventive Maintenance (PM) and Corrective Maintenance (CM) actions. So, maintenance keeps assets in an acceptable working condition, prevents them from failing, and, if they fail, brings them back to their operational level effectively and as quickly as possible.

## **1.2 Research Objective and Scope**

Inspection and maintenance activities are carried out aiming to improve the reliability and availability of the system. Nowadays, complexity and advancement in systems and equipment has increased significantly in Oil & Gas, Refineries and Petrochemical facilities. Due to this reason, inspection and maintenance activities are moving from the reactive and expensive mode (e.g., breakdown maintenance, failure-finding maintenance and corrective maintenance) to proactive based, cost effective and high service maintenance techniques and

approaches. Kobbacy et al. (2008) reported that a survey of some 34 companies was carried out in the UK, which indicated that around half of the work that was carried out by maintenance department was on repair; around a quarter was on preventive maintenance and 5% on inspection and the remaining was on other type of maintenance actions including opportunistic maintenance, condition monitoring and design-out maintenance. Some of the planned inspection and maintenance activities require the facility to be in non-operational state, generally termed “shutdown”. Inspection and maintenance activities carried out during a shutdown are generally called shutdown, turnaround or outage maintenance. Majority of the inspection and maintenance methodology published in literature has presented optimization strategies without considering the overall impact of facility shutdown. This research tries to overcome this limitation and provide a novel solution to optimize shutdown interval with a risk-based approach.

Unexpected failures of a component or equipment produce an unplanned or emergency shutdown (outage) of processing facilities which operate on a continuous basis. Loss of production and higher maintenance cost (due to unplanned nature) not only create significant financial impact but also customer dissatisfaction. Production loss, safety and environment issues due to unexpected failures can be minimized using an effective inspection and maintenance strategy. A risk-based shutdown for inspection and maintenance activities provides a cost effective strategy by using the information obtained from the study of failure mode and their consequences. It is a strategic decision for operating companies to bring a running plant into a state on non-operational state in order to carry out inspection and maintenance for components of the system in certain period over a planning horizon.



This research focuses on developing a risk-based shutdown inspection and maintenance interval optimization methodology for a processing facility. This methodology will help to identify a proper inspection and maintenance interval in view of the overall risk exposure (financial impact), and lead to avoid unwanted breakdowns in the facility.

The specific research objectives of this work are:

- (1) To develop a framework to estimate risk-based shutdown inspection and maintenance interval
- (2) To develop a risk-based methodology to estimate shutdown interval considering system availability.
- (3) To develop a risk-based shutdown inspection and maintenance interval considering human error for a processing facility.
- (4) To develop a multi-constrained, bi-objective risk-based maintenance scheduling for a LNG gas sweetening unit.

The endeavor of this research is to find the optimum shutdown interval to perform inspection and maintenance of a system such that the overall risk is minimized subject to a constraint on reliability and availability. The proposed methodology will provide a means to achieve the desired reliability and availability of the processing unit or facility under considered circumstances as illustrated in Figure 1-1: Overall research strategy.

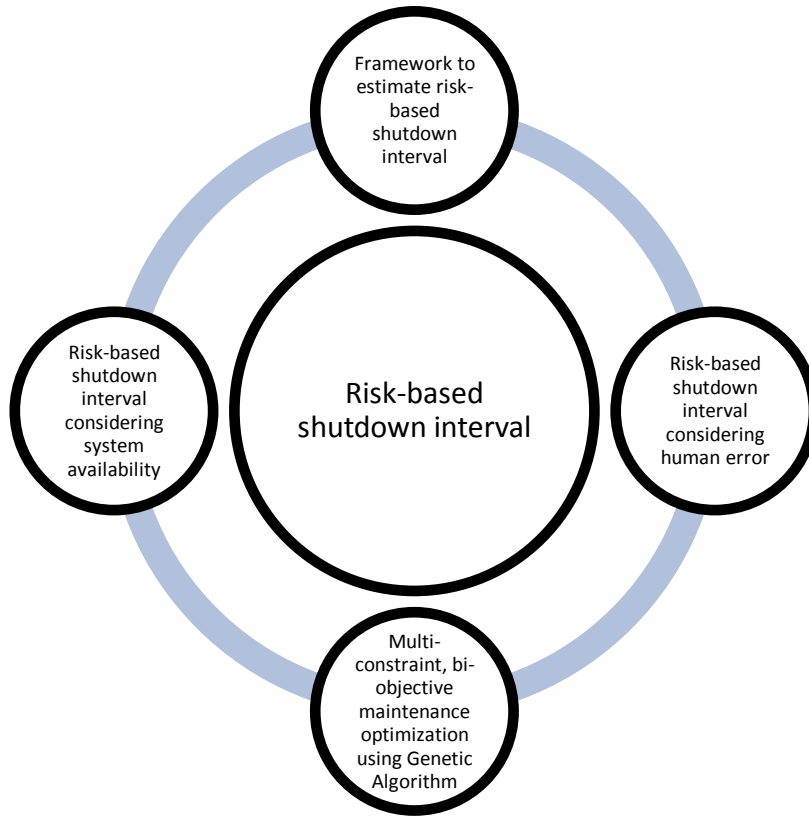

Figure 1-1: Overall research strategy

### 1.3 General Terminology and Definitions

To better understand the concepts in this dissertation, basic definitions and terminology are discussed in the following sub-sections.

#### 1.3.1 Shutdown

A duration in which a process facility is out of service and does not produce the desired outcome is termed as shutdown.

### **1.3.1.1 Planned/Scheduled Shutdown:**

Duffuaa and Daya (2004) and Lawrence (2012) have defined that a planned periodic shutdown (total or partial) of a processing unit or facility is the time taken to perform maintenance, overhaul and repair operations and to inspect, test and replace process materials and equipment. Planned/Scheduled shutdown can be classified as total and partial shutdown.

### **1.3.1.2 Total Shutdown:**

In a total planned shutdown, the entire process facility is taken out of service. This type of shutdown causes serious negative financial impact on business operations due to production loss and shutdown maintenance cost (labor and spare parts). Generally, planning for total shutdown begins well in advance and includes stakeholders such as procurement, engineering, maintenance, operations, quality assurance, Health, Safety, and Environment (HSE), security and administration.

### **1.3.1.3 Partial Shutdown:**

A partial shutdown is a scheduled short term shutdown. This type of shutdown is the result of critical equipment or process system deterioration for which the unit of the process facility has to be taken out for service. Generally, the duration of partial shutdown is short in nature. This type of shutdown may have some impact on the production rate, depending on the configuration of the plant.

### **1.3.1.4 Extended Shutdown:**

According to the International Atomic Energy Agency (IAEA) publication (2004), mothballing or extended shutdown is to place the facility in a condition of preservation in order to prevent degradation and to maintain the facility or part of the facility for future

usage. Mothballing is characterized by the treatment afforded to major components. Components and systems to be preserved may be physically removed from the environment in which they have been operating to a new environment where they are protected from degradation.

#### **1.3.1.5 Emergency Shutdown:**

The emergency shutdown is an unscheduled event which is initiated in the event of safety and/or environmental related issues such as fire, spill, etc., or due to a sudden failure of certain component or equipment which may produce or result in the loss of production. Emergency shutdown is triggered either by the operators or the safety interlock systems installed, to avoid failure of sophisticated and complex equipment such as compressors, pumps, turbines, boilers, furnaces, vessels etc.

#### **1.3.2 Maintenance and Inspections:**

Maintenance and inspections are activities carried out with the aim to improve the reliability and availability of the equipment or system. Some of these activities are inspection, cleaning, lubricating, adjustment, alignment and/or the replacement of components carried out in order to reduce the risk of failure. Some of the most important maintenance approaches are reviewed briefly here. Figure 1-2 shows a broad classification of maintenance activities.

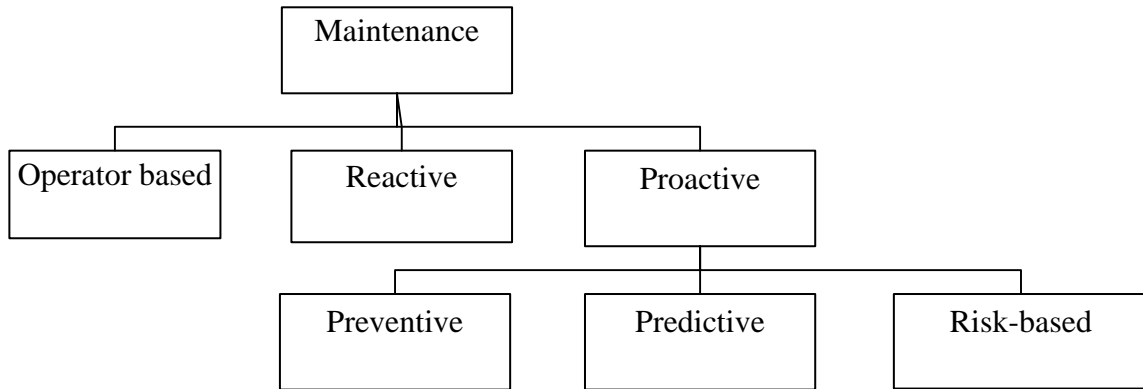

Figure 1-2: Types of maintenance

### 1.3.2.1 Reactive Maintenance:

Maintenance activities which are not planned and performed when an internal (inherent) or an external (operator-induced) failure is observed are called reactive maintenance. Run to failure, breakdown, corrective and emergency maintenance are reactive maintenance labeled as “unplanned”, having common characteristics with the objective to restore the equipment to a state in which it can perform its full intended function.

### 1.3.2.2 Proactive Maintenance:

Maintenance activities which are planned well in advance, to avoid any potential failure, whether internal (inherent) or external (operator-induced), are called proactive maintenance. Proactive maintenance is contrary to reactive maintenance. Preventive maintenance and predictive maintenance are proactive maintenance.

### **1.3.2.3 Preventive Maintenance:**

Duffua et al. (1999) and Dhillon (2002) reported that preventive maintenance can be defined as a series of planned tasks performed to counteract the known causes of potential failures of the intended function of an asset. Preventive maintenance can be planned based on time or usage. If the actual failure mechanism of an asset is known, certain maintenance action can be carried out and planned in advance to avoid failure. For example, if the failure mode is due to wear or usage and increases over a period of time, then the preventive maintenance will be time-based. The downside of preventive maintenance is that it increases system downtime as well as increases the possibility of induced failures which may negatively impact system availability and reliability.

### **1.3.2.4 Predictive Maintenance:**

Duffua et al. (1999) reported that predictive maintenance can be defined as a series of planned tasks performed to counteract the unknown causes of potential failures of the intended function of an asset by monitoring or inspecting the health of the asset. This type of maintenance strategy is also referred to as condition-based or diagnostic based maintenance. This strategy is very useful when the probability of failure is constant regardless of time, age, or usage, and there is a gradual degradation from the onset of failure. Gulati (2009) reported that the "predictive" component stems from the goal of predicting the future trend of the asset's condition. This approach uses the principles of statistical process control and trend analysis to determine at what point in the future, maintenance activities will be appropriate and cost effective.

### **1.3.2.5 Reliability Centered Maintenance:**

RCM strategy was developed in the commercial aviation industry in the late 1960s to optimize maintenance and operational activities in order to preserve critical aircraft functions. This strategy was adopted and published in Maintenance Strategy Group 1 (MSG-1), which was later approved by Federal Aviation Authority (FAA). In 1975, Department of Defense (DOD) directed that the MSG concept be labeled Reliability Centered Maintenance (RCM) and be applied to all major military systems (Gulati, 2009). Reliability centered maintenance is a proactive maintenance strategy which is based on an asset/system in its operating context to ensure safety, mission compliance, and system functionality. The process defines system boundaries and identifies functions, functional failures, and likely failure modes (Gulati, 2009).

### **1.3.2.6 Opportunity Maintenance:**

Duffuaa and Daya (2004) reported that maintenance activities which are not planned well in advance but rather carried out when the opportunity arises are called opportunity maintenance. Very often, this type of maintenance is carried out when the process plant/equipment enters in a planned or un-planned shutdown to perform maintenance and inspection activities. Such defects that are pointed out during operation, but could not be repaired, are maintained during shutdown.

### **1.3.2.7 Operator Based Maintenance:**

Stephens (2010) reported that in the operator-based maintenance strategy, plant or equipment operators, with help of formal training from maintenance department, can perform certain routine maintenance jobs such as house-keeping, equipment cleaning, protection from

dust, lubrication, routine inspection and routine adjustment as well as simple faults that can be easily taken care of by the production or operational staff. Telang et al. (2010) reported that operator driven maintenance strategy closes the gap between operation/production and maintenance and may help to achieve significant improvement in overall plant and equipment availability.

### 1.3.3 Risk

The word “risk” is widely used in the industries. This word is used to represent various conditions which are considered to be having a negative impact on the operating companies, such as business risk, economic risk, safety and environmental risk and injury or fatality risk. Risk is generally analyzed qualitatively or quantitatively. Kaplan and Garrick (1981) suggested that a qualitative risk analysis tries to answer three fundamental questions or the “set of triplets idea”:

- (1) What can go wrong?
- (2) How likely is it to happen?
- (3) What will be the consequences if it happens?

Once all the scenarios are covered, these sets of scenarios can be represented as a set of triplets as shown in the following equation:

$$Risk = \{ < S_i, P_i, X_i > \}, i = 1, 2, \dots \dots \dots N. \quad (1-1)$$

Further a quantitative risk is generally defined as the possibility of loss and injury and the degree of probability of such a loss. In this context, risk can be defined as:

$$Risk = Probability\ of\ failure \times Consequences\ of\ failure \quad (1-2)$$



The result of a quantitative risk analysis produces a number in \$ values/unit of time. This number is used by operating companies to decide their tolerance or acceptance criteria to meet their target or goal.

### **1.3.3.1 Failure and reliability function**

All equipment, either static or rotating degrades as the time passes or ages in operation. This degradation may result in a failure of the equipment or system. Generally, reliability of an equipment or system is defined as the probability that it will perform its intended function under a specified condition for the specified period of time without failure. In contrast, the probability that the equipment is in a failed state and unable to perform its required function is a complement to reliability. Mathematically, this is represented as:

For a given value of t,

$$R(t) + F(t) = 1 \quad (1-3)$$

where, R(t) is referred to as reliability function, and F(t) is the probability that failure occurs before time t.

$$F(t) = 1 - R(t) \quad (1-4)$$

### **1.3.3.2 Consequence of failure**

A failure or breach of containment can lead to various scenarios or hazards which may produce unwanted outcomes. Typically, in oil and gas or petrochemical industries, fire (Flash fire, Jet fire, Pool fire, and Fireball), and explosions (Boiling Liquid Expanding Vapor Explosion (BLEVE), Vapor Cloud Explosion (VCE), and Confined Vapor Cloud Explosion

(CVCE)), are considered to be major hazards events which may lead to devastated outcomes for the operating companies. Figure 1-3 briefly represents possible scenarios.

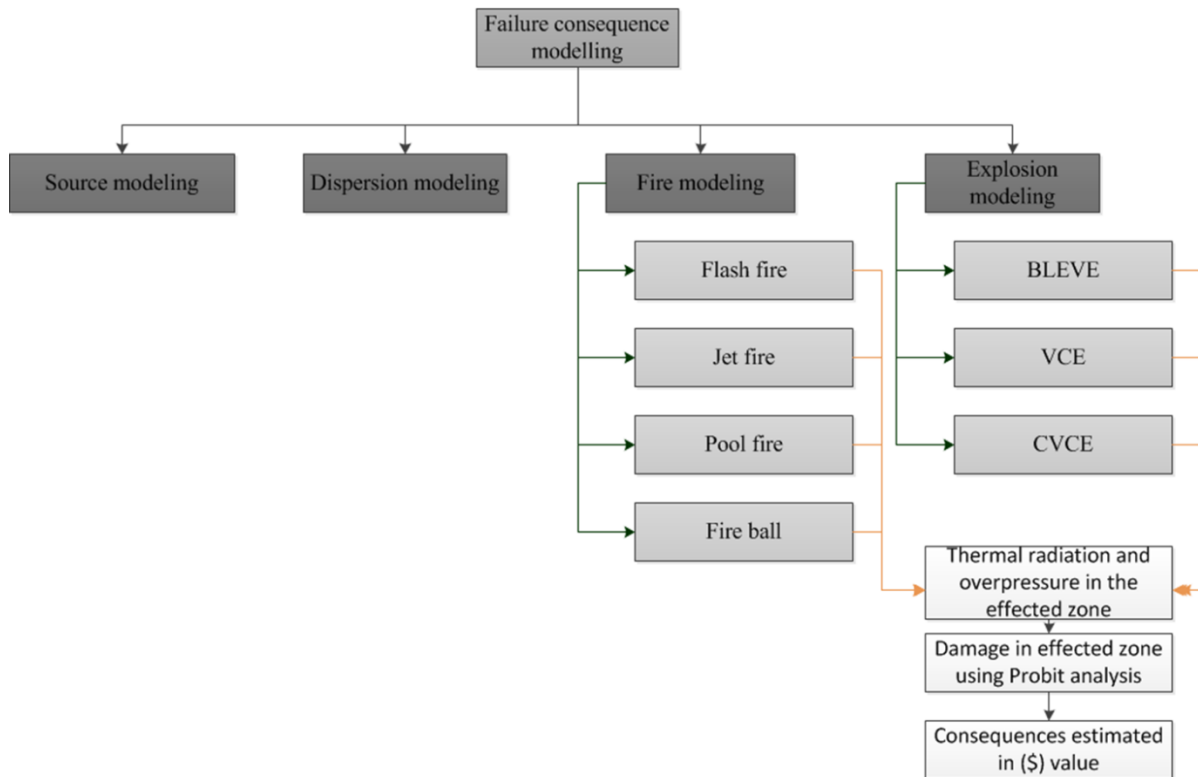

Figure 1-3: Failure consequence modeling

These consequences are estimated in terms of asset damage, production loss, health safety and environment and various inspection and maintenance costs and measured in \$ values as shown in Figure 1-4.

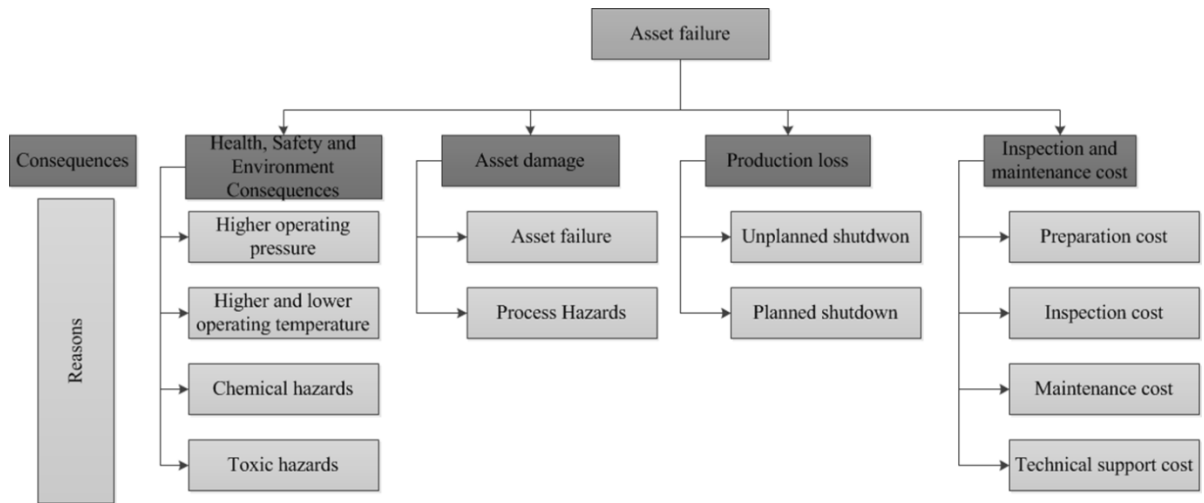

Figure 1-4: Asset Failure Scenarios and Hazards

### 1.3.4 Availability

Asset intensive industries such as petrochemical and hydrocarbon processing facilities operate on a continuous basis; 24 hours a day and 365 days a year. In order to maintain operability to meet the shareholders demands and to continue producing the output, availability of these assets is vital. Availability is one of the key measurement or performance indices for these industries. Higher availability indicates higher utilization of the facility. Ebeling (1996) defines availability as the probability that a system or component is performing its required function at a given point in time or over a stated period of time when operated and maintained in a prescribed manner. Availability is measured as the ratio of uptime and downtime of the facility, and represented as:

$$Availability = \frac{Uptime}{Uptime + Downtime} \quad (1-5)$$

where, uptime and downtime are generally represented in terms of mean time between failure (MTBF) and mean time to repair (MTTR). Using MTBF and MTTR, the availability equation can be represented as:

$$Availability = \frac{MTBF}{MTBF + MTTR} \quad (1-6)$$

### **1.3.5 Risk based Inspection and Maintenance (RBI&M):**

Maintenance strategies such as breakdown maintenance, preventive maintenance, condition monitoring and reliability centered maintenance were the main focus for reducing maintenance cost and improving plant operational reliability and availability. However, over the last two decades, a paradigm shift has been observed in which maintenance strategies are now coupled with the risk associated with the operating plants. A risk-based approach, compared to a fixed interval (conventional) approach, assesses the failure by considering not only the likelihood but also the consequences of total shutdown and failure.

## **1.4 Constraints and Limitations**

The proposal is based on a risk-based analysis. Quantification of risk requires having thorough understanding of equipment or system failure mechanism and failure probability. To calculate the failure probability of a component, equipment or system, failure data are required. Failure probabilities are primarily determined using physical plant data, test data, data banks and from the operating experience of plant personnel. Analyzing data without knowing the failure mechanism can lead to incorrect results. Depending on the availability of plant specific numerical data, failure rates can be estimated using the maximum likelihood

method, Bayesian reliability estimation or from a generic data base, if no raw data are available for a component. Some available industry databases e.g., Offshore and Onshore Reliability Data (OREDA) and Process Equipment Reliability Database (PERD), have documented failure and repair rates for different failure modes. In general, careful consideration is required in using this data since many of the failure modes are not applicable to all the processes. In this proposal, failure data for the selected critical equipment will be adopted from the available data banks, plant specific data as well as expert judgments.

## **1.5 Thesis Structure**

This thesis follows the sequence of objectives as discussed earlier. The Chapter structure is discussed as follows:

- Chapter 1 provides a brief introduction of the relevant terminologies discussed, such as shutdown and its types, inspection and maintenance and their types, operation performance measurements such as reliability, availability, and risk. Further, assumptions, limitations, research objectives are also mentioned.
- Chapter 2 discusses a novel framework to estimate risk-based shutdown interval for a processing facility. This chapter includes a discussion on the introduction of a risk-matrix for critical equipment selection to develop shutdown interval. Further, failure and consequence modeling for various failure scenarios is discussed and presented. Finally an operational risk profile is generated which is used considering the As Low As Reasonably Practical (ALARP) criteria to establish the shutdown interval. The proposed framework is applied and discussed to develop shutdown maintenance and inspection intervals for a gas chilling/liquefaction unit in a LNG processing plant.

- Chapter 3 describes the risk-based methodology to estimate shutdown interval considering system availability. Shutdown interval using plant availability as a constraint is discussed using Markov process. Availability of the system is estimated considering two different system configurations. Probabilities of failure and their consequences are presented. A novel concept of Mean Shutdown Time ( $M_{SDT}$ ) is proposed over the design life of the system, considering that the shutdown is a planned event in advance to obtain risk-based shutdown interval.
- Chapter 4 presents a novel risk-based methodology to estimate shutdown inspection and maintenance interval by integrating human errors. Probability of human error is introduced while modeling the system failure. Success Likelihood Methodology (SLIM) is used to estimate the human error probability (HEP). The proposed methodology is the extension of the previously published work by the authors to determine the shutdown interval, considering the system desired availability. The methodology is used to ensure the practicality of the proposed formulation to the real industry.
- Chapter 5 presents a multi-constrained, bi-objective non-linear maintenance scheduling optimization using Genetic Algorithm (GA). Further, in this chapter, the facility is split in to two main categories of equipment which help to develop a well-planned maintenance, considering planned shutdown and its financial impact. The benefits of maintenance can only be gained when a reliable performance with high availability and productivity is sustained without having frequent facility shutdowns. The two conflicting objectives are: i) the minimization of total expenditures incurred on maintenance related activities and ii) improving the total reliability of gas

sweetening unit. Finally a true Pareto-front using plant specific data and employing Genetic Algorithm Toolbox in MATLAB (Version 2015b) is presented. The developed approach is applied to construct the maintenance schedule for a processing facility unit.

- Finally, Chapter 6 presents the research conclusions with the key findings, presented novelties and contributions for the operating facility shutdown management. Further, possible opportunities to improve the shutdown modeling are also suggested to take this subject to the next higher level.

## CHAPTER 2

### **A framework to estimate the risk-based shutdown interval for a processing plant<sup>1</sup>**

#### **Abstract**

The proposed framework is a cost effective way to minimize the overall financial risk for asset inspection and maintenance, while fulfilling safety and availability requirements. Petrochemical plants and refineries consist of hundreds of pieces of complex equipment and machinery that run under rigorous operating conditions and are subjected to deterioration, over a time due to aging, wear, corrosion, erosion, fatigue and other reasons. These devices operate under extreme operating pressures and temperatures, and any failure may result in huge financial consequences for the operating company. To minimize the risk and to maintain operational reliability and availability, companies adopt various maintenance strategies. Shutdown or turnaround maintenance is one such strategy. In general, shutdown

---

<sup>1</sup> *This Chapter is based on the published work in a peer-reviewed journal. Hameed A., & Khan, F. (2014). "A framework to estimate the risk-based shutdown interval for a processing plant". Journal of Loss Prevention in the Process Industries, 32, 18–29. To minimize the duplication, all the references are listed in the reference list. The contribution of the authors is presented in Section titled, "Co-authorship Statement".*



for inspection and maintenance is based on the original equipment manufacturer's (OEM) suggested and recommended certain periods. However, this may not be the most optimum strategy given in which operating conditions may vary significantly from company to company.

The framework proposed in this work estimates the risk-based shutdown interval for inspection and maintenance. It provides a tool for maintenance planning and decision making by considering the probability of the equipment or the system for failure and the likely consequences that may follow. The novel risk-based approach is compared with the conventional fixed interval approach. This former approach, characterized as it is by optimized inspection, maintenance and risk management, leads to extended intervals between shutdowns. The result is the increase in production and the consequent income of millions of dollars.

## **2.1 Introduction**

Petrochemical plants and refineries consist of several pieces of equipment and machinery that are complex and run under rigorous operating conditions. They tend to deteriorate over time, due to aging, wear, corrosion, erosion, fatigue and other reasons. If the consequences of a failure are very low, the minimum amount of maintenance activity can be performed at the time of a failure. However, if the consequences of a failure are very high and are not addressed in a timely manner, the deterioration of equipment and system may result in unplanned shutdowns, production losses, higher production costs and in certain cases serious accidents and environmental issues.

To keep these losses low by minimizing the deterioration rate associated with time and operation, companies adopt different maintenance strategies by which to maintain the safety, reliability and availability of the systems, so that they may continue to operate smoothly. Shutdown maintenance is one of the maintenance management strategies used in process plants to improve the plant reliability, availability and integrity. Reliability is very important for any processing plant given that any equipment failure may result in safety consequences (e.g., injuries or loss of life and the company's reputation), financial damages (e.g., production losses and damages to assets) and environmental consequences. Some of the planned inspection and maintenance activities cannot be performed if the plant is operational and require the unit or plant to be in a non-operational state. This category of maintenance is referred to as shutdown, turnaround or outage maintenance. Lawrence (2012) reported that refineries and other petrochemical facilities that run continuously must shut down operations every few years to provide access to production units so that essential maintenance, modification and inspection work can be carried out. To achieve a predefined operational reliability goal, companies adopt preventive maintenance strategies based on the original equipment manufacturer's suggested fixed intervals of maintenance. However, these suggested intervals may not be the most optimum maintenance strategy, given that the operating conditions may vary significantly from company to company. Based on case studies performed for six major process plants in the United Kingdom, Obiajunwa (2012) reported that typically power plant shutdown (turnaround) maintenance is planned for every four years, oil refinery and petrochemical plant shutdown maintenance is planned for every two years, and chemical, steel, glass and food and beverage plant shutdown maintenance is planned for every year. Tan and Kramer (1997) reported that a typical refinery experiences

approximately 10 days of downtime per year due to equipment failures, with an estimated economic loss of \$20,000-\$30,000, per hour. Shutdown maintenance is critical to oil and gas companies as the availability of operating facilities has a major impact on the company's profitability through the cost of the event and the revenue loss due to the plant being offline. The average production losses due to planned shutdowns based on a fixed interval strategy have a significant financial impact amounting to millions of dollars, which can be minimized by adopting a risk-based shutdown interval strategy.

If the system deterioration can be modeled, it is possible to predict the time for failure, and maintenance action can be planned on the basis of the service age and the anticipated failure time. A risk-based shutdown maintenance interval methodology not only extends the interval between shutdowns but also produces millions of dollars in savings.

## **2.2 State-of-the-art on shutdown inspection and maintenance:**

In recent years, shutdown maintenance strategies have emerged as a critical management decision to achieve optimal output for a unit or a plant, while keeping the overall costs low and maintaining safety and regulatory requirements. In the last two decades, a paradigm shift (risk-based maintenance strategies) has been observed, in which maintenance strategies are now coupled with the specific risk associated with the operating plant. It is likely that this reason that has influenced researchers to focus more on risk-based maintenance management approaches. Different risk-based maintenance and inspection approaches are reported in the literature, ranging from the qualitatively ones to the quantitative ones. Duffua and Daya (2004) reported that shutdown maintenance (also termed as turnaround maintenance) is a periodic maintenance where plants are shutdown to allow

time for inspections, repairs, replacements and overhauls, that can be carried out only when the assets (plant facilities) are taken out of service. During this period, three types of work are carried out: (1) work on equipment that cannot be performed unless the whole plant is shutdown, (2) work that requires a lengthy maintenance and a large number of maintenance personnel and (3) maintenance on defects that are discovered during normal operations but cannot be repaired. Duffua, Raouf, and Cambell (1999), and Lenahan (1999) both extensively discussed detailed requirements for shutdown (turnaround) maintenance. Pokharel and Jiao (2008) reported that if project management practices and the involvement of external experts and parties are allowed during maintenance projects, then issues in maintenance projects can be more clearly addressed and the cost and schedule for such a project can be minimized. Levitt (2004) discussed five phases of shutdown: planning, initiating, executing, completion and closeout. Duffua et al. (1999), Duffua and Daya (2004), Lenahan (1999) and Levitt (2004) covered only the management and execution portions of shutdown and have not addressed the important question regarding shutdown intervals to improve plant reliability and availability. Zulkipli et al. (2009) reported that the studies regarding turnaround (shutdown) maintenance are descriptive and highly narrative in nature. The shutdown (turnaround) event is considered duration-driven, and the frequency is largely determined by variables such as plant technology, the required level of plant reliability, and the legal requirements associated with the operation. Ghosh and Roy (2009) proposed optimizing the maintenance intervals by maximizing the reliability based cost/benefit ratio. Rusin and Wojaczeck (2012) presented optimization of power machine maintenance intervals by taking the risk into consideration. Vaurio (1995) presented a procedure for optimizing test and maintenance intervals for safety related systems and components. This procedure was

based on minimizing the total plant-level cost and setting an upper bound, on the total accident frequency (risk). Khan and Haddara (2003) developed a risk-based maintenance (RBM) strategy interval for periodic preventive maintenance (PM) on key equipment. Khan and Haddara (2004a, 2004b) applied the risk-based maintenance (RBM) strategies to offshore oil and gas processing facilities to develop a maintenance plan and extended similar strategies to an ethylene oxide production plant. Krishnasamy, Khan and Haddara (2005) proposed a risk based maintenance strategy for a power plant. The strategies listed by Khan and co-authors are intended to develop an optimized inspection and maintenance program based on integrating a reliability approach and a risk assessment strategy. The desired end product is an optimum maintenance schedule that reduces the overall risk for the plants based on the individual equipment in the plant. However, these methods are deficient in considering the overall financial impact of plant shutdown on the facility and the frequency of the maintenance shutdown interval. Tan and Kramer (1997) proposed a general framework for preventive maintenance optimization that combines Monte Carlo simulations with a genetic algorithm. When applied to opportunistic maintenance problems, the method overcomes the demonstrated shortcomings using analytic or Markov techniques in terms of solution accuracy, versatility and tractability. Duarte, Craveiro, and Trigo (2006) proposed optimizing the preventive maintenance plans of a series of components to ensure availability under the assumption that all of the components in the system exhibit a linearly increasing hazard rate, a constant repair rate and that preventive maintenance returns the system to 'as good as new' condition. Vatn, Hokstand, and Bodsberg (1996) presented an overall model for maintenance optimization for the components of a production system considering safety, health, maintenance costs, environment objectives and the cost of lost production. Keshavarz,

Thodi, and Khan (2011) proposed a risk-based shutdown management strategy for LNG units. A combination of preventive maintenance, active redundancy and standby redundancy was considered to achieve an optimized shutdown maintenance strategy. This work failed to address the equipment selection criteria for the shutdown interval characterization of the plant, which is a key issue as far as optimizing the shutdown maintenance interval is concerned. Hadavi (2009) proposed a heuristic single function model incorporating cost, risk and loss for outage maintenance scheduling optimization. Fujiyama et al. (2004) developed a risk based maintenance system for steam turbine plants coupled with a quick inspection system. The objective was to provide a rational basis for life cycle maintenance planning. Tam, Chan, and Price (2006) reported that in the manufacturing industry, PM is carried out to minimize the probability of unexpected plant breakdown. Suggested PM intervals are normally determined by the OEMs. However, they observed that due to the multi-faceted relationship between the operating context and the production requirements for different plants, it is unlikely that these OEM suggested intervals are optimized for plant specific conditions. Additionally, these authors proposed three models to calculate the optimal maintenance intervals for a multi-component system in a factory with a minimum required reliability, maximum allowable budget and minimum total cost.

API Recommended Practice 580 (2009) provides guidance to owners, operators, and designers of pressure-containing equipment, including pressure vessels, process piping, storage tanks, rotating equipment (with pressure containing components), boilers and heaters, heat exchangers and pressure-relief devices. API Recommended Practice 581 (2008) provides quantitative procedures to establish an inspection program using risk-based methods for pressurized fixed equipment, including pressure vessels, piping, tankage, pressure relief

devices, heat exchangers, pumps and compressors. In literature, extensive work on inspection and maintenance modeling is available, however, very limited application is observed related to the modeling of shutdown for a processing unit or plant. Some of these methods have been discussed in details in literature to estimate optimal maintenance and inspection interval considering cost, risk, availability and reliability. However, they all tend to optimize individual equipment inspection and maintenance cycle. The efforts towards finding an optimal inspection and maintenance interval is not considered in these studies especially when it requires the unit or plant to be in non-operational (shutdown) state, from an operational state for performing inspection and maintenance on the equipment. If an inspection and maintenance strategy is developed only by giving consideration to individual equipment reliability and availability point of view, it will have a major impact on the return on investment for shareholders, lead to higher operating expenses and in some cases result in loss of market share. The Risk-based Shutdown Inspection and Maintenance Methodology (RBSIM) proposed in the present work, is a unique quantitative approach which enables us to find a unit or plant shutdown interval which will provide an optimal inspection and maintenance interval considering the overall system availability, reliability and risk. The proposed RBSIM is designed to optimize the plant shutdown interval and maintain a high level of equipment availability considering the critical equipment from the risk perspective, while ensuring that the overall financial impact is kept to a minimum, considering the critical equipment from risk perspective. RBSIM provides an efficient way to select the equipment based on the risk and direct impact on plant operability to manage assets in comparison to the individual equipment strategy by efficiently utilizing inspection and maintenance resources and thus achieve better results with less operating expenses.

## **2.3 Risk-based shutdown inspection and maintenance interval (RBSIM)**

### **methodology**

In this study, a framework to establish risk-based shutdown intervals is presented. This framework is broken down into three main modules, as shown in Figure 2-1:

1. Risk-based equipment selection for shutdown interval estimation
2. Estimation of failure data and failure consequences
3. Establishing a risk-based optimized shutdown interval

### **2.3.1 Module 1: Risk-based equipment selection for shutdown interval estimation.**

According to Zulkipli et al. (2009) tasks carried out during shutdown maintenance include overhauls, maintenance, replacement, inspection, tie-ins for plant expansions and modifications and upgrades. Duffua and Daya (2004) reported that during shutdown (turnaround), maintenance is performed on that equipment, which necessarily requires that the whole plant is shutdown and on defects that are discovered during operation that cannot be repaired or which require a lengthy repair period and a large number of maintenance personnel.

To estimate the shutdown interval or provide enhancement, the focus must be placed on equipment failure probabilities that have the most significant impact on system failure. In a typical operating plant, thousands of pieces of equipment and components are operating. It is very unlikely that a shutdown interval can be based on all of the equipment. The overall financial impact of the shutdown for inspection and maintenance activities can be offset by



reducing excessive equipment selection by removing those pieces that exhibit a lower risk to reliability, availability and safety.

Process industries such as oil, gas or petrochemical industries are exposed to risk which relates to financial losses due to losses in production and to operating risks associated with higher operating pressures, lower temperatures (cryogenic), as well as toxic and chemical hazards. To avoid or minimize these risks, risk-based equipment selection is proposed to help estimate the best risk-based shutdown intervals.

This process begins with a qualitative risk-based study for equipment selection in reference to the imposed risk on the facility and the performance of the equipment. This module proposes a unique risk assessment strategy to select the critical equipment that affects the functionality of the system. To achieve this, operating plants need to be divided into manageable units/systems to identify pertinent equipment or components. To minimize, the exposed risk to the company, each unit needs to be analyzed, to identify the equipment with the largest impact on the plant operability, reliability, availability, financial impact (e.g., production loss, asset damage due to failure and revenue loss due to shutdown), as well as the possible impact on safety and the environment. This cycle continues until the whole unit or plant is analyzed. The output from this qualitative risk assessment is a categorization of the equipment that exhibits a significant impact on the operability of the unit or plant.

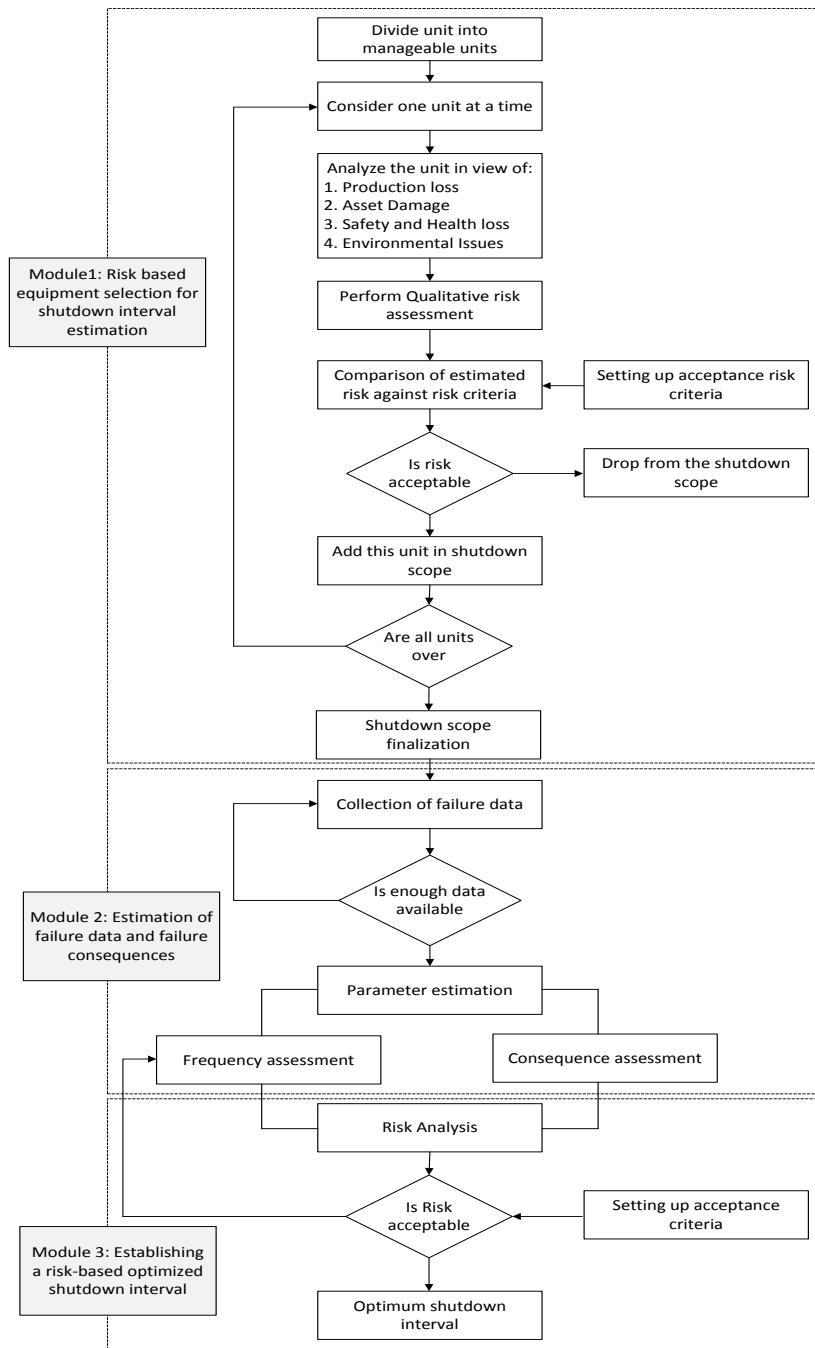

Figure 2-1: Frame work to estimate risk-based shutdown interval

A qualitative criticality risk ranking matrix (see Figure 2-2: Qualitative Criticality risk ranking matrix) is proposed to select critical equipment which cannot be inspected or repaired if the plant is in operation. A level of severity and probability of failure from 1 to 5

is assigned to each category. For the case of several competing consequences for equipment/components, the highest observed risk among the consequences should be considered to be the most critical component.

Risk Matrix						
Failure Frequency						
Frequent	5	M	H	H	H	H
Probable	4	L	M	M	H	H
Occasional	3	L	M	M	M	H
Remote	2	L	L	M	M	H
Extremely Unlikely	1	L	L	L	L	M
Consequence Rating		1	2	3	4	5
Asset Damage		Negligible	Minor	Moderate	Major	Catastrophic
Production Loss		<5%	5- 10%	10-30%	30-60%	>60%
Safety/Health		Near miss/ First Aid	Minor Injury	Injury with Disability	Permanent Disability	Fatalities
Environment		No effect	Minor effect	Moderate effect	Major effect	Massive effect

Figure 2-2: Qualitative Criticality risk ranking matrix

Operational relationships and knowledge regarding various system elements is required to perform shutdown interval estimation. System failures cannot be evaluated and improved until it is known that how these various elements affect system operation. A true representation of these relationships is required for prediction and assessment based on either cost or risk. Reliability block diagrams are usually used to represent these relationships. For a system comprising various elements (equipment), reliability diagrams are a good means of

showing the functional relationship between the elements and providing an indication of the elements which must operate successfully for the system to accomplish its intended function. An operating plant may constitute pieces of equipment arranged in series, active redundancy or standby redundancy. Typical reliability block diagrams are shown below (Figure 2-3 & Figure 2-4).

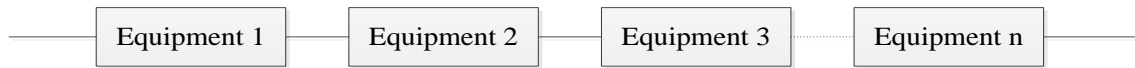

Figure 2-3: Block diagram showing equipment acting in series

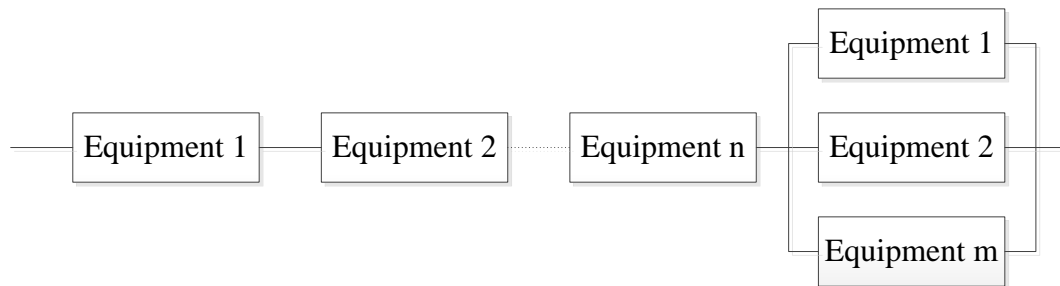

Figure 2-4: Block diagram showing equipment acting in series/parallel configuration

Furthermore, this study assumes that a piece of equipment/component in standby arrangement or active redundancy has the full capacity to undergo inspection and maintenance without requiring, that the operating plant be placed into a non-operational state.

### **2.3.2 Module 2: Estimation of system failure probability and failure consequences**

A failure of a piece of equipment or a system is defined as its inability to perform its intended function as per stated procedure in a defined environment. A partial failure may

result in a reduction of process throughput, whereas a complete failure will stop the entire process operation. Failures are generally modeled as a stochastic process. A stochastic process can be defined using a probabilistic method. Ebeling (1997) reported that the reliability of a piece of equipment or a system is defined as the probability that it will perform its intended function without failure for a given period of time. The failure of a piece of equipment or a system is complementary to the reliability and is written mathematically as:

$$R_{sys}(t) + F_{sys}(t) = 1 \quad (2-1)$$

$$F_{sys}(t) = 1 - R_{sys}(t) \quad (2-2)$$

### **2.3.2.1 System Failure Probability:**

A failure can be modeled using exponential, Weibull, normal or lognormal probability distributions. However, Weibull distributions provide a more generalized failure model and often are used in reliability analyses due to this model's inherent flexibility. Additionally, Weibull distributions can mimic the behavior of other statistical distributions, such as normal (for  $\beta = 3.4$ ) and exponential (for  $\beta = 1$ ) distributions. A decreasing failure rate ( $\beta < 1$ ) corresponds to an early life failure or infant mortality. A constant failure rate ( $\beta = 1$ ) suggests that items are failing from random events. An increasing failure rate ( $\beta > 1$ ) suggests that wear out is occurring and that parts are more likely to fail over time (Ghosh & Roy, 2009). The value of the shape parameter ( $\beta$ ) estimated from the failure data provides an insight into the failure processes of the equipment. This includes reliable operation for certain durations and when the device enters into the wear out zone. All maintenance activities are based on this assumption so that action can be taken before any failures occur. It is necessary

to express the probability of failure for a piece of equipment or a system as a function of time for risk-based shutdown maintenance and inspection interval estimation. In this study, the Weibull model with the parameters  $\beta$  and characteristic life ( $\theta$ ) is used to model the time dependent reliability of the equipment involved in the system. Ebeling (1997) reported that the reliability of equipment following the Weibull distribution is defined as:

$$R(t) = e^{-\left(\frac{t}{\theta}\right)^\beta} \quad (2-3)$$

$$\lambda(t) = \left(\frac{\beta}{\theta}\right) \left(\frac{t}{\theta}\right)^{\beta-1} \quad (2-4)$$

The variable  $R_i(t)$  is defined as the reliability of the equipment in a system that has not had any maintenance or inspection during a time  $t$  but is scheduled to undergo inspection and maintenance during a shutdown. Ebeling (1997) reported that the system failure probability prior to the shutdown maintenance and inspection is given as:

For a System in a Series Configuration (Figure 2-3):

$$F_{sys}(t) = 1 - \prod_{i=1}^n R_i(t) \quad (2-5)$$

$$R_i(t) = \exp\left[-\left(\frac{t}{\theta_i}\right)^{\beta_i}\right] \quad (2-6)$$

where  $i = 1, 2, \dots, n$  pieces of equipment acting in series, as shown in Figure 2-3, and:

For System in Series/Parallel Configuration (Figure 2-4):

$$F_{sys}(t) = 1 - \left[ \prod_{i=1}^n R_i(t) \times \left[ 1 - \prod_{j=1}^m (1 - R_j(t)) \right] \right] \quad (2-7)$$

where  $i = 1, 2 \dots n$  pieces of equipment acting in series and  $j=1, 2 \dots m$  pieces of equipment acting in parallel, as shown in Figure 2-4.

### 2.3.2.2 Estimation of failure probability parameters

To calculate the failure probability of a component, equipment or a system, failure data are required. Noortwijk, Dekker, Cooke, and Mazzuchi (1992) proposed a comprehensive method to use expert opinion for obtaining the lifetime distributions required for maintenance optimization. Failure probabilities are primarily determined using physical plant data, test data, data banks and from the operating experience of plant personnel. Analyzing data without knowing the failure mechanism can lead to incorrect results. Cizelj, Mavko, and Kljenak (2001) reported that estimation of a component failure rate depends on the availability of plant specific numerical data and proposed a new method that explicitly adds numerical and linguistic information into the assessment of a specific failure rate using a Bayesian updating approach. Depending on the availability of plant specific numerical data, failure rates can be estimated using the maximum likelihood method, Bayesian reliability estimation or from a generic data base if no raw data are available for a component. For this study, failure data for the selected critical equipment are adopted from the OREDA (2002). Keshavarz et al. (2011) reported that by using different causes of failure, number of failures, and demand for equipment reported in OREDA, the reliability of any component may be calculated in the following way:

$$R(t) = 1 - F(t) = 1 - \frac{n}{N} \quad (2-8)$$

where  $n$  is the number of critical failures and  $N$  is the demand.

As no information is listed in OREDA on the time of individual failures, it is fair to assume a constant mean time between failures for any specific cause. A simultaneous solution of Eq. (2-3) and Eq. (2-4) is used to obtain the distribution parameters  $\beta$  and  $\theta$  for any piece of equipment.

### **2.3.2.3 Economic failure consequences:**

Failure modes for process equipment (static or rotating) need to be assessed to perform inspection and maintenance activities. Maintenance activities can be as simple as lube oil analysis, lube oil replacement or a complete replacement of a degraded component. For example, a catastrophic failure of a pump bearing may result in damage to the casing, ring, impeller, and mechanical seal. A failure of a threaded drain connection due to corrosion in a process vessel may result in the release of a large amount of hydrocarbons. If a pump operating in a gas processing plant under extreme pressure or temperature fails catastrophically and releases hydrocarbons, it may form a vapor cloud and result in an explosion in the presence of an ignition source. The consequences of these failures are not only limited to mechanical damage of the equipment but may also cause significant damage to nearby assets, production loss, serious health and safety issues and environment impacts. These consequences can be calculated based on the effects of thermal radiation and overpressure on surrounding equipment and personnel and subsequently converted in the monetary (\$) terms that are assumed to be invariant with time. Improper inspection or maintenance of processing units may result in severe failure consequences. The purpose of



risk-based shutdown maintenance and inspection interval modeling is to minimize the consequences of these failures by reducing the risk associated with deterioration or aging effects. The total economic consequences of these failures include asset losses, human health losses, production losses and the cost of maintenance and inspections. Each of these economic consequences is discussed briefly in the following section.

#### **2.3.2.4 Economic Consequences of Asset Loss (ECAL):**

To determine any damage to surrounding assets due to various hazards resulting from a hydrocarbon release, such as flash fires, jet fires, pool fires, fire balls, VCE, CVCE, BLEVE, or toxic dispersion in a processing plant, consequence effect zones ( $m^2$ ) in terms of overpressure level are calculated to establish asset losses. The assessment of consequence effect zones and their impact involves many models, such as source modeling, dispersion modeling, fire and explosion models. A large number of computer software packages are available to perform these types of analyses. However, in this study, an analytical model is used to calculate overpressure in the effected zones due to an explosion (Crowl & Louvar, 2002) and converted into probability of damage due to overpressure using probit analysis (Assael & Kakosimos, 2010). The main parameters required to perform these calculations are operating pressure, temperature, physical and chemical properties, and atmospheric conditions. Asset loss is estimated for each accident scenario using the following equation:

$$ECAL = PDOP \times EZ \times AD \quad (2-9)$$

where *PDOP* is the probability of damage due to overpressure, *EZ* is the effected zone due to overpressure and *AD* is asset density.

### **2.3.2.5 Economic Consequences of Human Health Loss (ECHHL)**

The loss of life or pain suffered due to equipment failure or degradation has a severe impact on the operation of the facility and the operating company's perception in the eyes of the public. Although it is difficult to calculate the impact of the loss of life or pain suffered to one's family, the cost due to compensation and corporate liability needs be taken into account in terms of economic consequences, which vary from company to company. Judycki (1994) of the US Department of Transportation and the Federal Highway Administration published a technical note relating the injury scale (in terms of severity) to the comprehensive costs in police-reported crashes. The figures of this previous study are used hereinto calculate the financial impact on companies for human fatalities or injuries.

Similar to the calculation of asset loss, human health loss is calculated in terms of dollars for each scenario using the following equation:

$$ECHHL = PDOP \times EZ \times PD \times CF \quad (2-10)$$

where *PDOP* is the probability of damage due to overpressure, *EZ* is the effected zone due to overpressure, *PD* is population density and *CF* is cost of injury or fatality.

### **2.3.2.6 Economic Consequences of Production Loss (ECPL):**

The consequences of production loss are the product of downtime and the production loss volume:

$$ECPL = SDT \times PL \times SP \quad (2-11)$$

where *SDT* denotes the shutdown time in days, *PL* is production loss volume per day and *SP* is the selling price of the product per unit volume.

The shutdown time includes the total amount of time, the plant would be out of operation (from the moment it is stopped to the moment it is again fully operational).

### **2.3.2.7 Economic Consequences of Shutdown Inspection and Maintenance Costs (ECSIM):**

Shutdown inspection and maintenance costs include scheduled inspection and maintenance costs for a group of equipment or components. These costs include the cost of preparation (scaffolding, insulation removal, blinding, purging, etc.), the cost of inspection (visual inspection, hydro jetting, eddy current testing, etc.), the cost of maintenance activities and materials (spare parts, maintenance materials, tools and vehicles associated with maintenance or inspection jobs), and the cost of technical support.

#### **2.3.2.7.1 Preparation cost:**

The preparatory cost can be estimated in the following manner:

$$C_p = C_{lp} \times t_1 \quad (2-12)$$

where  $C_p$  is the preparatory cost (\$),  $C_{lp}$  is the cost of preparatory maintenance labor per hour (\$/h) and  $t_1$  is the duration of the work.

#### **2.3.2.7.2 Inspection cost:**

The inspection cost can be estimated with the following equation:

$$C_i = C_{li} \times t_2 + C_{ie} \times t_3 \quad (2-13)$$

where  $C_i$  is the inspection cost (\$),  $C_{li}$  is the cost of skilled inspection labor per hour (\$/h),  $C_{ie}$  is the cost of inspection equipment per hour (\$/h),  $t_2$  is the duration of the work and  $t_3$  is the duration of the required equipment.

#### **2.3.2.7.3 Maintenance cost:**

The maintenance cost can be estimated in the following manner:

$$C_m = C_{lm} \times t_4 + C_{sp} \quad (2-14)$$

where  $C_m$  is the maintenance cost (\$),  $C_{lm}$  is the cost of skilled maintenance labor per hour (\$/h),  $C_{sp}$  is the cost of spare parts consumed and  $t_4$  is the duration of the work. The cost of spare parts includes replacement parts, consumables, internally manufactured parts, parts sent out for repairs at vendor's facilities, special equipment and treatments. Spare part cost can be drawn from the plant warehouse book.

#### 2.3.2.7.4 Technical support cost:

The technical support cost can be estimated with the following equation:

$$C_{ts} = C_{lts} \times t_5 \quad (2-15)$$

where  $C_{ts}$  is the technical support cost (\$),  $C_{lts}$  is the cost of a technical support specialist per hour (\$/h) and  $t_5$  is the duration of the work in hours.

The economic consequences of shutdown inspection and maintenance are the following:

$$ECSIM = C_p + C_i + C_m + C_{ts} \quad (2-16)$$

The total economic consequences of failure are the following:

$$EC_T = \max(ECAL + ECHHL)_i + \sum_{i=1}^n ECSIM + ECPL \quad (2-17)$$

where  $i = 1, 2, 3, \dots, n$  is the equipment identified from the criticality matrix and considered for shutdown interval estimation.

### 2.3.3 Module 3: establishing risk-based optimized shutdown inspection and maintenance interval

The risk-based plant shutdown inspection and maintenance interval optimization model is a mathematical model in which both the risks and the benefits of maintenance are quantified in terms of failure probability.

Schon (1980) defined risk as a statement concerning the damage probability depending on both the frequency of occurrence and the extent of possible expected (either direct or indirect) damage to all kinds to life and health. The risk may be described by a suitable combination ( $\times$ ) of the frequency of occurrence of an undesirable event with the probable extent of the damage expected upon occurrence. Muhlbauer (2004) wrote that the most commonly accepted definition of risk is often expressed as the following mathematical relationship:

$$RISK_e = \textit{Event likelihood} \times \textit{Event Consequence} \quad (2-18)$$

$$RISK_e = F_{sys}(t) \times \sum \textit{Economic Consequence of failure} (\$) \quad (2-19)$$

$$RISK_e = (1 - R_{sys}(t)) \times \sum \textit{Economic Consequence of failure} (\$) \quad (2-20)$$

Where  $RISK_e$  is the estimated operational risk, which varies with time because the probability of failure is a function of time. The objective of this study is to obtain a risk-based plant shutdown inspection and maintenance interval with an acceptable risk and to

determine the time at which the estimated risk is equal to the acceptable risk. Thus, Eq. (2-19) is subject to the following condition:

$$RISK_e \leq RISK_{acceptable} \quad (2-21)$$

Acceptable risk is defined as the level of acceptance for shutdown inspection and maintenance planning purposes. For economic based consequence analysis, the acceptable risk is defined in terms of the financial limits. Each operating company defines its own tolerable risk criteria. This risk criterion should be used when making an estimation of risk-based shutdown interval.

#### **2.4 The application of RBSIM to an onshore processing facility unit**

The above-proposed methodology has been used to develop shutdown maintenance and inspection intervals for a gas chilling/liquefaction unit in a LNG processing plant. The plant considered in this study employs the AP-X<sup>TM</sup> Hybrid liquefaction process, licensed by Air Products and Chemicals Inc. (APCI). The AP-X<sup>TM</sup> process cycle is an improvement on the C3MR process in that the LNG is sub-cooled using a simple, efficient nitrogen expander loop rather than a mixed refrigerant. A schematic process flow of this unit is shown in Figure 2-5.

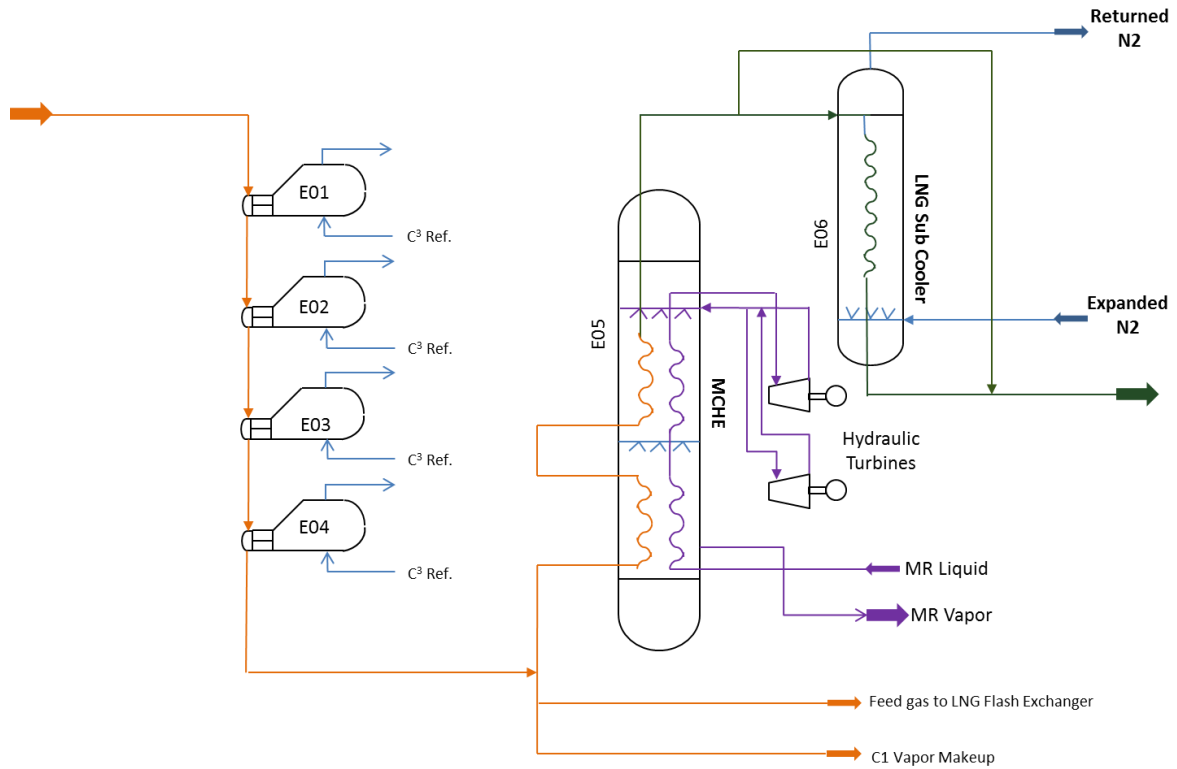

Figure 2-5: Process flow schematic of a gas chilling/liquefaction unit

## 2.5 Results & discussions

### 2.5.1 Module 1

The main purpose of the gas chilling and liquefaction unit is to condense the natural gas into LNG in the main cryogenic heat exchanger (MCHE) and sub-cool it in the Sub-cooling Heat Exchanger or the LNG Sub Cooler. The sweetened, dry and lean feed gas from the LNG recovery unit enters the Gas chilling and liquefaction unit and is chilled by vaporizing propane refrigerant in the exchangers (high, medium, low, and low-low pressure level), as shown in the block diagram. The propane vapors generated during chilling are

returned to the propane compressor via suction drums. After pre-cooling with propane refrigerant, the feed gas is liquefied in the MCHE, which uses a mixed refrigerant. It is then sub-cooled in the LNG Sub Cooler, which uses nitrogen as the refrigerant. The proposed risk matrix is applied to select the critical equipment from gas chilling and liquefaction unit (Table 2-1). A block diagram of the critical equipment selected for this unit is shown in Figure 2-6. It is evident that to perform any maintenance and inspections on any of these equipment, the unit (plant) must be placed in the shutdown mode.



Figure 2-6: Block diagram of the critical equipment selected for a gas chilling/liquefaction unit

Table 2-1: Critical equipment selected from gas chilling and liquefaction unit

<b>Chilling and Liquefaction Unit:</b>	
Equipment No.	Description
E01	Feed Gas/HP C3 Exchanger
E02	Feed Gas/MP C3 Exchanger
E03	Feed Gas/LP C3 Exchanger
E04	Feed Gas/LLP C3 Exchanger
E05	Main Cryogenic Heat Exchanger
E06	Sub Cooling Heat Exchanger/ LNG Sub Cooler



## 2.5.2 Module 2

System failure probability is calculated using the block diagram shown in Figure 2-6. As the equipment in this unit operates in series, Eq. (2-5) is appropriate for this scenario. To calculate the system failure probability, the Weibull distribution parameters for the selected equipment are estimated using the method described in section 2.3.2.2. The estimated values are shown in Table 2-2. As no data for the MCHE and the LNG Sub Cooler is available in the history of operation for these components in OREDA, and considering that it has not failed and is highly reliable, a characteristic life and shape parameter is adopted based on expert judgment.

Table 2-2: The failure rate data for the equipment considered in this case study

Equipment No.	Characteristic life ( $\theta$ , h)	Shape Parameter ( $\beta$ )
E01		
E02		
E03	282,000	4.38
E04		
E05		
E06	450,000	2.0

Failure scenarios such as VCE for equipment E01 to E05 and VCE and Asphyxiation are considered for equipment E06 as listed in Table 2-3. These failure scenarios are subjected to consequence assessment. Given that the equipment described here involves the processing of hydrocarbons and operates at extreme conditions, the consequences of any failure will be very high. The last column in Table 2-3 shows the consequences of asset loss and human

health loss at the study point. This clearly shows that these consequences will have a major financial impact due to asset damages and human injuries or fatalities. Judycki (1994) of the US Department of Transportation and the Federal Highway Administration published a technical note relating the injury scale (in terms of severity) to the comprehensive costs in police-reported crashes. This note is used to calculate the financial impact on companies for human fatality or injuries.

Table 2-3: Failure scenarios and their estimated consequences

Equipment No.	Accident Scenario	Accident Scenario Description	Consequences of Asset Loss and Human Health Loss at study point (all values in million dollars)
E01			344.98
E02	VCE (Vapor Cloud Explosion)	Release of hydrocarbons from any of the equipment, which upon finding an ignition source may result in vapor cloud explosion, causing shock wave damaging assets and humans.	307.29
E03			256.40
E04			88.34
E05			284.18
E06	VCE (Vapor Cloud Explosion) and Asphyxiation	a) Release of hydrocarbons from the equipment, which upon finding an ignition source may result in vapor cloud explosion, causing shock waves damaging assets and humans. b) Release of N <sub>2</sub> vapors, which upon physical contact may produce asphyxiation, resulting in human injuries or fatalities.	377.76

U.S. Energy Information Administration (2012) has published the LNG price in \$/thousand cubic feet. The same is used in this study to calculate the economic consequences of production loss.

### 2.5.3 Module 3

The estimated results of the consequences and failure probability of a unit are combined to quantify the operational risk. In general, the acceptable risk will be different from one company to another. An ALARP for this particular study is assumed to be \$100/h. or lower. Any value higher than this is not acceptable. Given that the considered failure rate of the selected equipment is time dependent, the operational risk changes over the time period that the unit is in operation. A comparison of the estimated operational risk with the acceptable risk helps to determine the optimal shutdown inspection and maintenance intervals under the considered risk criteria. The optimized risk-based shutdown inspection and maintenance interval is found to be **23,663 h** as shown in Figure 2-7. Estimated shutdown interval is considered to be an optimal solution under the assumed risk acceptability criteria. A conventional approach for inspection and maintenance interval based on the individual equipment does not consider the system unavailability resulting facility shutdown. Further, the consequences would be much higher with a conventional approach (based on individual equipment) as it does not consider, the overall facility shutdown, specifically production loss, leading to a higher risk.

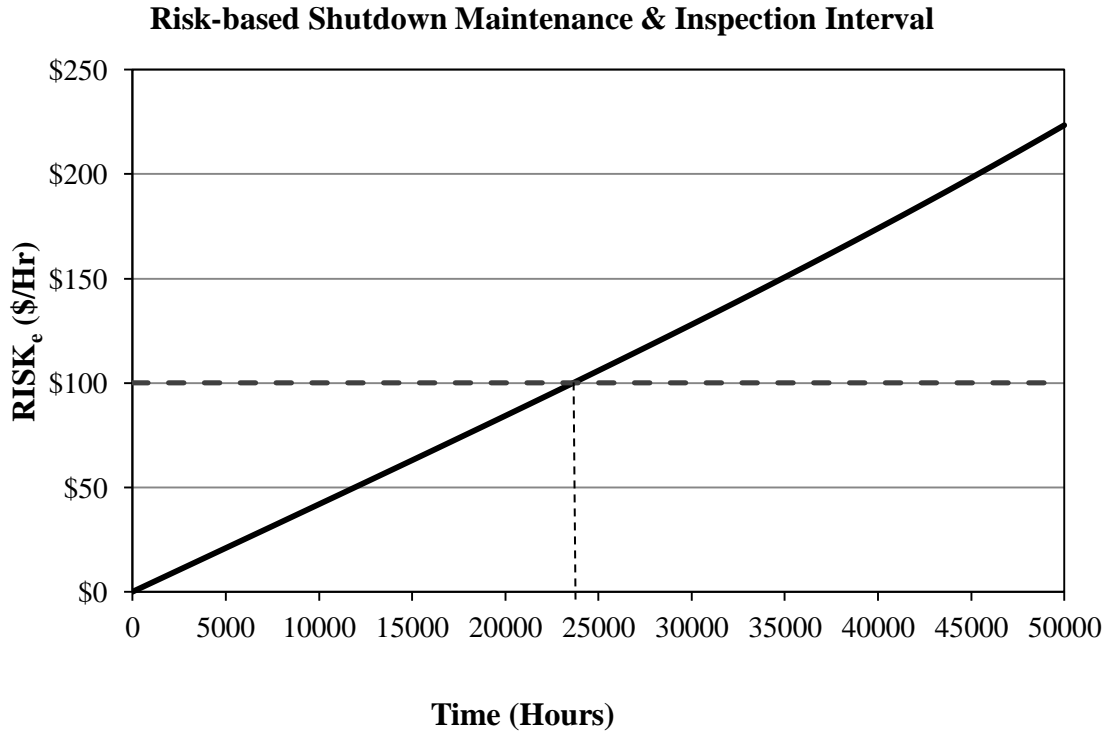

Figure 2-7: Risk-based shutdown maintenance & inspection interval

## 2.6 Summary and Conclusions

In this study, a new framework for risk-based shutdown interval estimation for inspection and maintenance is proposed. The proposed methodology differs from the various maintenance scheduling methodologies available in the literature in that it considers the selection of equipment based on the actual risk to which a company may be exposed when selecting the shutdown interval of a unit or plant for maintenance and inspection. The methodology is composed of three main modules: (1) risk-based equipment selection for shutdown interval estimation, (2) estimation of failure data and failure consequences and (3) establishing the risk-based optimized shutdown interval.

This methodology helps to optimize shutdown intervals for the inspection and maintenance of a processing unit or plant while considering the exposed risk related to production, safety and environment. It minimizes the financial consequences for an operating company due to production loss, loss of assets, safety (e.g., injury or loss of life) and environmental consequences.

The proposed methodology has been applied to obtain an optimum shutdown interval for a liquefied natural gas chilling and liquefaction unit, ensuring that the high level of risk is contained at an acceptable level. Such a shutdown interval optimization approach is expected to provide a cost-effective maintenance and inspection program and provide better asset and capital utilization. Estimated shutdown interval for maintenance and inspection are based on assumed ALARP criteria. As these criteria vary for different operating companies, the shutdown interval can be increased or decreased accordingly. The proposed RBSIM methodology can be easily applied to any processing facility, however, proper attention must be given to identify the most critical equipment which can be inspected or maintained only when the plant is in the non-operational (shutdown) state. A process plant consists of a large number of equipment and components which interact together under severe operating conditions such as high pressure, high and low temperatures and flow, thereby making the estimation of consequences an uphill task. A risk matrix must reflect a company's risk criteria as it will differ significantly from those of the other companies. It should ensure that appropriately experienced personnel from engineering, operations, SHE and the maintenance team ( with a good understanding of the system, failures, hazards, impact on operations and the consequences if the inspection and maintenance is delayed beyond a certain period) are

involved in performing risk assessment. Effective tools and methods should be utilized for the same. Other essential elements that govern the success of the methodology are:

- (1) An appropriate risk matrix that reflects organizational commitment,
- (2) Credible risk acceptance criteria developed considering the long term perspectives such as process safety and business interruption,
- (3) An effective data collection protocol to support risk assessment and evaluation of management strategies, and
- (4) Most importantly, safety culture. These non-technical elements require the unwavering commitment of the senior management.

## CHAPTER 3

### **A risk-based methodology to estimate shutdown interval considering system availability<sup>2</sup>**

#### **Abstract**

This paper presents a risk-based methodology to estimate shutdown inspection and maintenance interval considering system availability. Most inspection and maintenance activities are performed when the plant/unit is in the operational state. However, some inspection and maintenance activities require the plant to be in a non-operational or shutdown state. In most cases, operating companies adopt a shutdown schedule based on the original equipment manufacturer's (OEM) suggested recommended periods. However, this may not be the best strategy as OEM recommended duration is general and may not reflect the current state of operation. The proposed methodology is unique in the sense that it identifies a shutdown interval by identifying the critical equipment in terms of risk

---

<sup>2</sup> *This Chapter is based on the published work in a peer-reviewed journal. Abdul Hameed, Faisal Khan, Salim Ahmed (2015), "A risk-based methodology to estimate shutdown interval considering system availability," Process Safety Progress, Volume 34 (3), pages 267-279. To minimize the duplication, all the references are listed in the reference list. The contribution of the authors is presented in Section titled, "Co-authorship Statement".*



considering availability and safety of the operating unit. It optimizes process plant shutdown interval to minimize the risk (in dollar terms). The Markov process is used to establish the state diagram to calculate system availability. The proposed methodology is comprised of three steps namely, risk based equipment selection, shutdown availability modeling of a complex system using the Markov process and risk-based shutdown inspection and maintenance interval modeling. It can be applied to process plants such as those for LNG processing, petrochemicals and refineries. The key elements for the success of the proposed methodology are the plant specific data and identification of critical equipment.

### **3.1 Introduction**

Inspection and maintenance have evolved from a nonissue into a strategic concern in a short span of time. Mourbray (1997) reported that over the last few decades, maintenance has changed more than any other management discipline. The changes are due to a huge increase in the number and the variety of physical assets (plant, equipment and buildings), more complex design, new maintenance techniques and changing views on maintenance organization and responsibilities.

In general, a complex system consists of a large number of interacting components or equipment that performs the system's required functions. The system is subject to periodically or non-periodically planned inspection and maintenance during its life cycle. The inspection and maintenance actions are generally taken to fix a piece of equipment if it is found defective and having the potential to fail or to perform preventive maintenance to avoid any possible failure. In certain cases, these equipment or system cannot be isolated to perform inspection and maintenance, and this requires the plant to be taken out of service,

which is known as shutdown or turnaround. Shutdowns are generally classified as sudden or emergency and non-emergency shutdowns as shown in Figure 3-1. The sudden or emergency shutdown is an unscheduled event which is initiated in the event of a failure or breach of containment (such as fire, major spill, instrument failure, power failure, or total loss of control of chemical or physical processes). Non-emergency shutdowns can be further classified as planned or unplanned shutdowns. According to Duffuaa & Daya (2004) and Lawrence (2012), a planned, periodic shut down (total or partial) of a processing unit or facility is carried out to perform maintenance, overhaul and repair operations and to inspect, test and replace process materials and equipment. Generally, planning for total shutdown begins well in advance and involves the departments of procurement, engineering, maintenance, operations, quality assurance, HSE, security, and administration. An unplanned shutdown is initiated when a possible failure scenario seems to exist but does not require immediate stoppage of the operation, and can be delayed for a few weeks. Both planned and unplanned shutdowns can be total or partial in nature. In extended shutdown a facility is put in a condition of preservation to prevent degradation over time for future usage. The focus of this article is on planned shutdown, both total and partial.

Shutdown inspection and maintenance management is one of the maintenance management strategies used in continuously operating plants to improve plant reliability, availability and integrity.

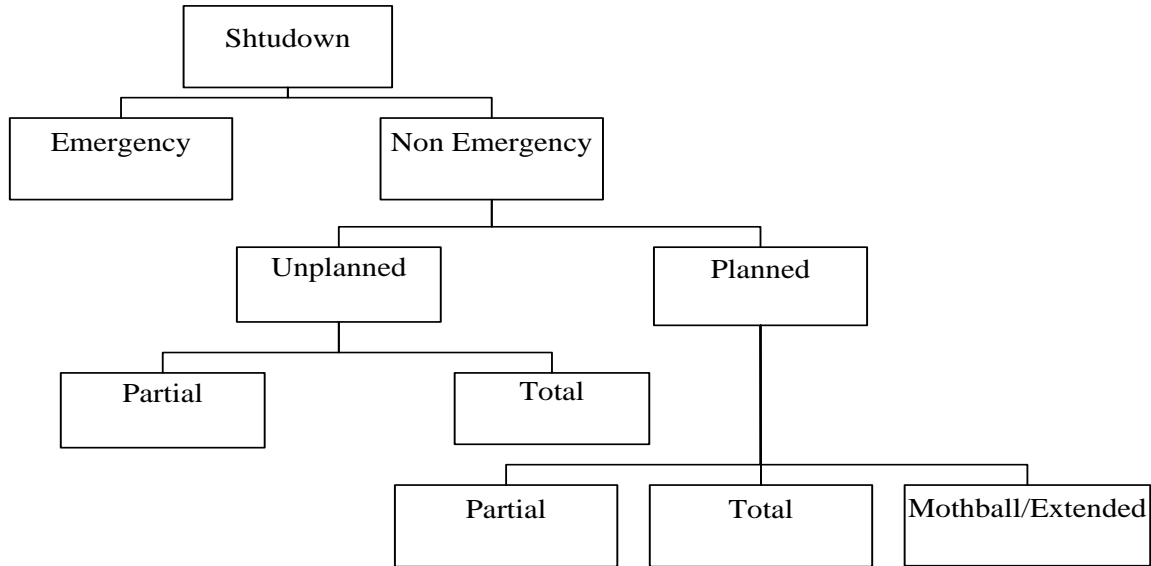

Figure 3-1: Shutdown Classification

Extensive literature is available on inspection and maintenance interval modeling considering cost, reliability, availability and risk. Inspection and maintenance intervals can be estimated on equipment by equipment basis. However, in a process plant, a unit or system consists of hundreds of pieces of equipment that run in continuous mode. Developing an inspection and maintenance strategy without considering the impact of these inspection and maintenance cycles over the operability of the plant will not produce an optimum interval. This problem could be solved by considering a risk-based critical component selection and by developing an optimized shutdown inspection and maintenance interval for the system. Risk, reliability and availability are interminably interlinked. Higher risk means lower reliability and availability, while higher availability means higher reliability and lower risk. In order to quantify the associated risk to the operating plant due to equipment or component failures, estimation of consequences is essential. Failure of a complex system results in not

only the loss of revenue due to production loss but also asset damages, safety and health issues and inspection and maintenance costs.

Khan et al. (2008) have presented a risk-based methodology to estimate the optimal inspection and maintenance intervals which maximize a system's availability by considering risk-based inspection and maintenance program to reduce the risk of failure and enhance the overall availability of the system. Sarkar and Behra (2012), Bertolini et al. (2009), Kumar and Chaturvedi (2008), Zhaoyang et al. (2011) and Wang et al. (2012) proposed that the risk-based maintenance approach provided a mean to reduce the overall risk when selecting a maintenance strategy. Neil and Marquez (2012) considered a hybrid Bayesian network (HBN) framework to model the availability of renewable systems. In this approach, HBNs were used to model distributions for corrective repair time, logistics delay time and scheduled maintenance and combine these with time- to-failure distributions to derive system availability. Jacob and Amari (2005) explored the difficulties in determining reliability and availability for repairable and non-repairable systems. The analysis is difficult when the failure distribution is not exponential and becomes even more difficult when the systems are hybrid and complex rather than only series, parallel or a combination of the two. A binary decision diagram to calculate a system's reliability and availability is presented (Jacob & Amari, 2005). Pil et al. (2008) proposed a concept of reliability assessment of re-liquefaction systems with focus on redundancy optimization and maintenance strategies based on a time dependent Markov approach. Penrose (2009) presented a tool for time to failure estimation for risk-based reporting of condition based maintenance tests and inspections to improve the effectiveness of the maintenance program by prioritizing corrective action. Khan and Haddara (2003) proposed a comprehensive and quantitative methodology for risk-based

maintenance. This methodology comprises of risk estimation module, risk evaluation module, and maintenance planning module by integrating reliability with safety and environmental issues and used as a decision tool for preventive maintenance planning. Risk-based approach has been applied successfully to the maintenance of oil pipelines (Dey et al., 1998), and Dey (2001). Krishnasamy et al., (2005) applied a risk-based maintenance strategy in developing cost-effective maintenance policies for critical equipment of a power-generating plant by reducing the overall risk of the plant. Krishnasamy et al., (2005) reported that the profitability is closely related to the availability and reliability of the equipment. Alsyouf (2007) presented a model which enables the decision-makers to trace how an effective maintenance policy could influence the productivity and profitability through its direct impact on quality, efficiency and effectiveness of operation. Backlund and Hanu (2002) reported that risk analysis depends on various factors and therefore the focus must be put on the function required of the subsystem and equipment. Fujiyama et al. (2004) developed a risk-based maintenance system for steam turbine plants coupled with a quick inspection system. The objective was to provide a rational basis for life cycle maintenance planning. Duffua et al. (1999), Duffua and Daya (2004), Lenahan (1999) and Levitt (2004) covered only the management and execution portions of shutdown and have not addressed the important question regarding shutdown intervals to improve plant reliability and availability. Keshavarz et al. (2011) proposed a risk-based shutdown management strategy for liquefied natural gas (LNG) units. However, it did not address the equipment selection criteria for the shutdown interval.

Thus, keeping in view the existing work, the objective of this article is to develop a risk-based methodology for a continuous processing facility to estimate shutdown interval for

optimal inspection and maintenance, considering complex system unavailability using the Markov model. This proposed methodology will provide a rational basis to make a shutdown interval inspection and maintenance decision considering the availability of the unit or plant and overall risk exposure.

### **3.2 A risk-based Shutdown Interval Methodology (RBSIM)**

Although extensive work on inspection and maintenance interval estimation modeling is available in the literature, a very limited number of studies are there on shutdown inspection and maintenance modeling for a continuous operating facility. Authors such as Ghosh and Roy (2009), Rusin and Wojaczeck (2012), Vaurio (1995), Khan and Haddara (2003, 2004a, & 2004b), Krishnasamy et al. (2005), Tan and Kramer (1997), Duarte et al. (2006) and Vatn et al. (1996) have discussed methods to estimate the optimal maintenance and inspection interval considering cost, risk, availability and reliability. However, most of these studies are concerned with optimizing individual equipment inspection and maintenance cycles. The efforts towards finding an optimal inspection and maintenance interval is not considered in these studies, especially when it requires a unit or plant to be in nonoperational (shutdown) state from an operational state. This work has been carried out to bridge the existing gap in the literature and to provide a means to develop a methodology to estimate the shutdown inspection and maintenance interval for a continuous processing unit or plant rather than an inspection and maintenance interval for each piece of equipment. The proposed methodology to determine risk-based shutdown inspection and maintenance intervals is presented in the following sections. This framework is broken down into three main modules as shown in Figure 3-2:

- (a) Module I: Risk-based selection of critical equipment
- (b) Module II: Shutdown availability modeling using the Markov model
- (c) Module III: Risk-based shutdown interval estimation

### **3.2.1 Module 1: Risk-based selection of critical equipment**

Duffua and Daya (2004) reported that during shutdown (turnaround), maintenance is performed on the equipment that cannot be performed unless the whole plant is taken out of service. In a typical operating plant where thousands of equipment and components are operating, it is very unlikely that a plant as a whole can be taken offline to perform inspection and maintenance based on individual equipment. It will have severe financial consequences due to loss of production. A better approach will be to focus on the selection of equipment which cannot be inspected or repaired during the plant operation. This will help to reduce the frequent production losses due to shutdowns of the facility for each individual equipment inspection and maintenance.

This module proposes a qualitative risk-based study for equipment selection with reference to the imposed risk on the facility and the performance of the equipment for taking the plant into shutdown mode. To achieve this, operating units or plants need to be divided into manageable systems to identify pertinent equipment or components. To minimize the exposed risk to the company, each unit needs to be analyzed to identify the equipment with the largest impact on the plant operability, reliability, availability, financial impact (e.g., revenue loss due to shutdown, asset damage due to failure, etc.), as well as the possible impact on safety and the environment. This cycle continues until the whole unit or plant is analyzed. The output from this qualitative risk assessment is a categorization of the equipm-

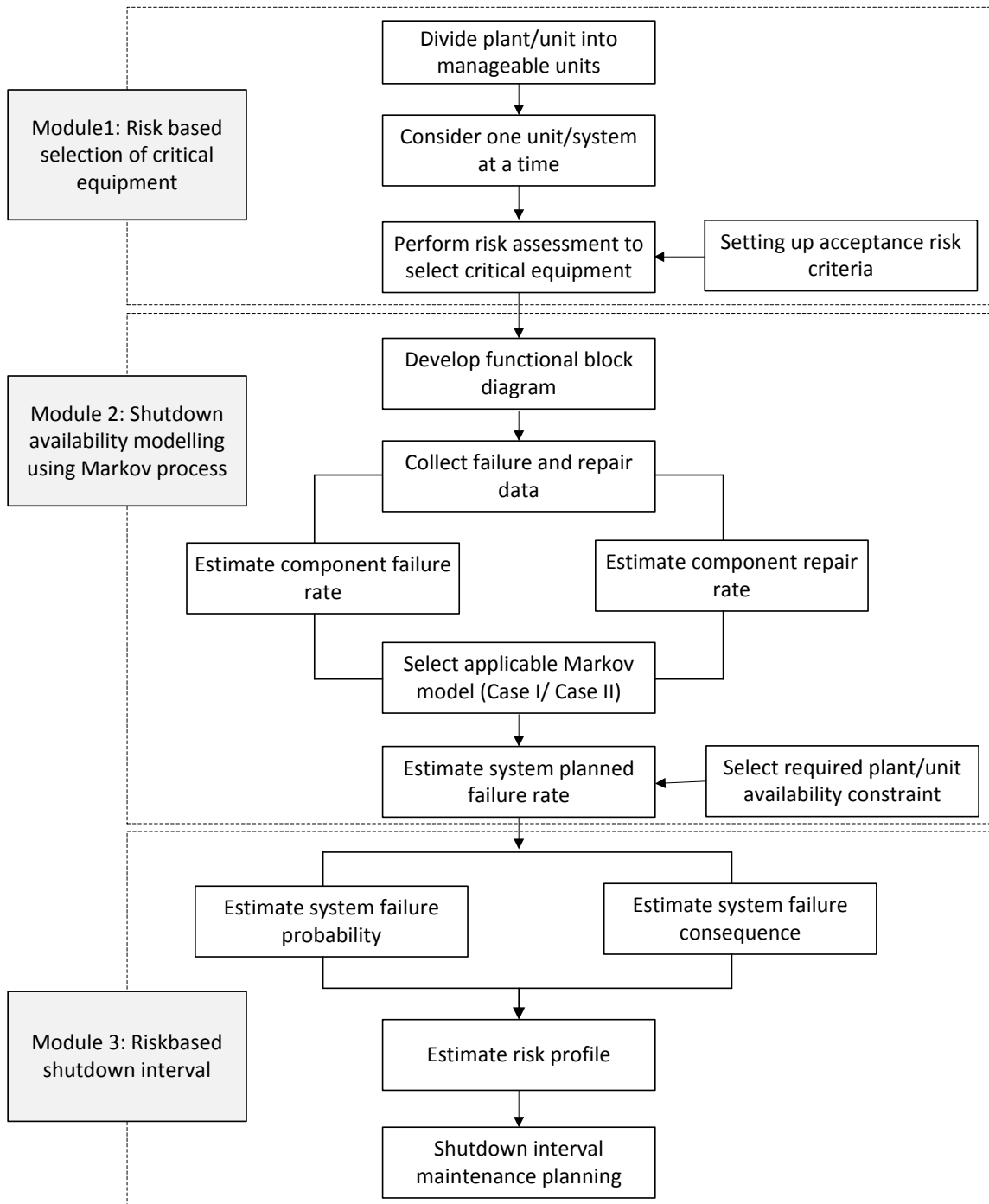

Figure 3-2: Risk-based shutdown interval methodology



-ment that exhibit a significant impact on the operability of unit or plant. API recommended practice API-580 (2009) provides the basic guidelines to develop a risk matrix. These guidelines have been used to establish the proposed risk-matrix as shown in Figure 3-3. According to API-580, (2009) for a qualitative risk analysis, the probability of failure (POF) may be categorized from one through five. However, it is appropriate to associate an event frequency with each probability category to provide guidance to determine the probability of failure as shown in Table 3-1. POF can be assessed separately for each unit, system, equipment grouping or individual equipment item. Similarly, consequences are represented in monetary terms (\$) as shown in Table 3-2.

Schon (1980) defined risk as a statement concerning the damage probability depending on both the frequency of occurrence and the extent of possible expected (either direct or indirect) damage to all kinds. The risk R, may be described by a suitable combination ( $\times$ ) of the frequency of occurrence of an undesirable event with the probable extent of the damage expected upon occurrence. Using the above definition, the risks associated with safety and health ( $RISK_{SH}$ ), production loss ( $RISK_{PL}$ ), asset loss ( $RISK_{AL}$ ) and environment ( $RISK_E$ ) can be calculated. For the case of several competing consequences for equipment/components, the highest observed risk among the consequences should be considered. The outcome of this risk assessment will enable the selection of the most critical set of equipment that may result in functional failure of a unit or a system and will require to go for shutdown inspection and maintenance. Overall risk can be selected using Eq. (3-1):

$$RISK = MAX(RISK_{SH}, RISK_{PL}, RISK_{AL}, RISK_E) \quad (3-1)$$

Risk Matrix						
Failure Frequency						
Frequent	5	M	H	H	H	H
Probable	4	L	M	M	H	H
Occasional	3	L	M	M	M	H
Remote	2	L	L	M	M	H
Extremely Unlikely	1	L	L	L	L	M
Consequence Rating		1	2	3	4	5
Asset Damage		Negligible	Minor	Moderate	Major	Catastrophic
Production Loss (DT in Hrs.)		DT<X	DT>X<X1	DT>X1<X2	DT>X2<X3	DT>X3
Safety/Health		Near miss/ First Aid	Minor Injury	Injury with Disability	Permanent Disability	Fatalities
Environment		No effect	Minor effect	Moderate effect	Major effect	Massive effect

Figure 3-3: Qualitative criticality risk ranking matrix

Table 3-1: Five levels of probability of failure

Possible qualitative rank	Annual failure probability or frequency
Frequent	>0.1
Probable	0.001 to 0.01
Occasional	0.0001 to 0.001
Remote	0.00001 to 0.0001
Extremely Unlikely	<0.000001

Table 3-2: Five level consequence table

Possible qualitative rank	Economic loss range
Negligible	$EL < \$10,000$
Minor	$\$10,000 < EL \leq \$100,000$
Moderate	$\$100,000 < EL \leq \$1,000,000$
Major	$\$1,000,000 < EL \leq \$10,000,000$
Catastrophic	$EL > \$10,000,000$

### 3.2.2 Module II – Shutdown availability modeling using the Markov process

In the life cycle of a plant, a component or a system, the duration for which it works can be defined as operational state with duration “d” until it undergoes into a fail or repair state. This leads to unavailability of the system which is generally referred to as unplanned shutdown. The component or system remains in the nonoperational state until a repair is completed with duration “r” and it starts delivering its intended function. This cycle of operation and shutdown continues throughout the lifetime of the component or system and can be represented as shown in Figure 3-4. An alternative approach is a planned cycle of inspection and maintenance of the systems, which cannot be inspected or maintained while in operation.

Availability of a component or a system is one of the most important measures to analyze its performance. Since availability is a probability, the rule of probability theory may be applied to compute the system availability from the knowledge of component or system availability. Markov analysis looks at a system as being in one of several states. One possible

state, for example, is that in which all the components comprising the system are in operation. Another possible state is that in which one component has failed but the other components continue to work. A third possible scenario is that a component failure leads to system failure. Markov model can be extended to the repairable component or system assuming that both the failure rate and repair rate are constant (exponential distribution). A majority of the components or systems in a process facility can often be modeled using a two state Markov process. For example, the simplest case for determining the steady state availability is a single component system that has a failure rate ( $\lambda$ ) and a repair rate ( $\mu$ ). Assume that the system will be in either one of the two possible states, Operational state (1) or Shutdown state (2) under repair or failed condition. This can be represented using a transition rate diagram as shown in Figure 3-5:

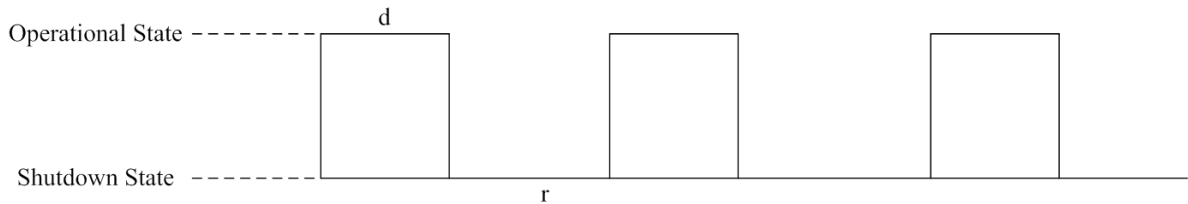

Figure 3-4: Operational and shutdown state of a repairable system

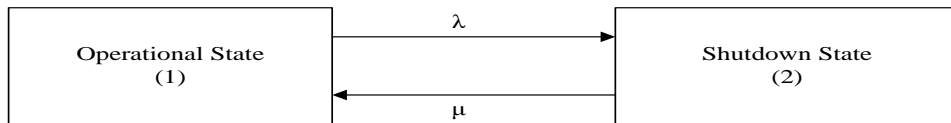

Figure 3-5: Markov state space diagram of a single component repairable system

Simple equipment is designed to perform few basic functions and is typically exposed to only one possible failure mode. However, a complex system performs multiple functions and consists of a number of items that can fail. Nowlan and Heap (1978) have reported that six different failure patterns exist as shown in Figure 3-6. NASA (2000) reported that random failures accounted for 77-92% of the total failures and age related failure characteristics accounted for the remaining 8-23% failures. Since 77-92% of the failures seem to follow constant failure rate, it is fair to assume the exponential distribution while modeling the availability of complex systems.

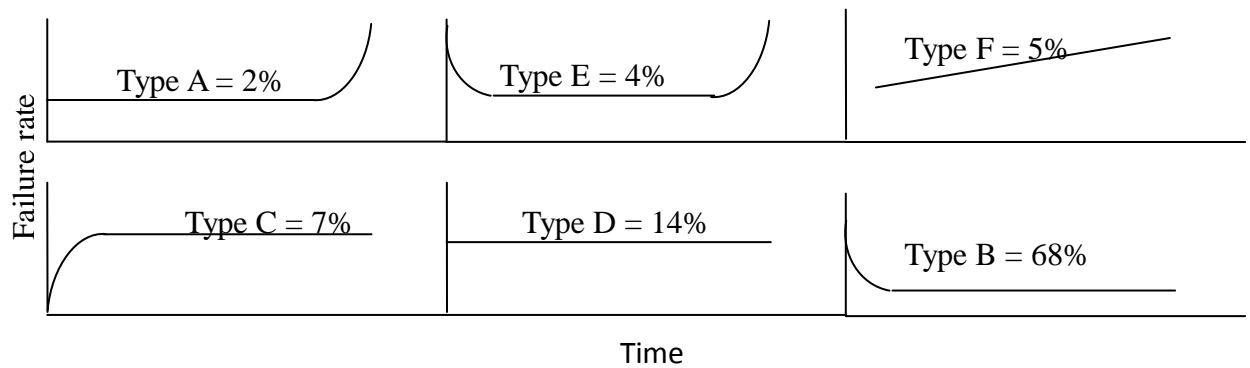

Figure 3-6: Illustration of failure patterns (redrawn after Nowlan and Heap, 1978)

Considering that 77-92% of the failures are random in nature (exponential distribution), Markov process can be extended to the complex system. Steady-state availability can be calculated using the Markov rate diagram. Steady state equations may be written for each state  $i$  on the basis of a general relationship as given in Eq. (3-2).

$$\sum_j (\text{Rate into state } i \text{ from state } j) \times P_j \quad (3-2)$$

$$= (\text{rate out of state } i) \times P_i$$

Letting  $P_i$  be the probability of being in state  $i$  and  $P_j$  in state  $j$ , the steady state equation can be written to calculate the availability or unavailability of the system. In general, the summation of all state probabilities remains equal to 1 as shown in Eq. (3-3).

$$P_1 + P_2 + \dots + P_n = 1 \quad (3-3)$$

In the life cycle of a process plant, a system can be in the state of unplanned shutdown for repair due to the failure which has already happened or in a planned shutdown to perform the inspection and maintenance activities to improve the availability and reliability. The parameters of the distributions for unplanned shutdown can be estimated from failure data over the life cycle of the plant. If a planned shutdown is treated as a random event then the state space diagram for an unplanned shutdown and a planned shutdown can be modeled under two scenarios namely Case I and Case II.

### 3.2.2.1 Case I

Complex industries consist of multiple equipment configurations. These arrangements can be either full standby or active redundant. Full stand by and active redundant configurations provide contingency to the operation of the facility in case of any unforeseen failure and help to avoid the unplanned shutdown. In a standby system, the primary unit is in operation while the other units are in standby. If repair of the primary unit is feasible when it is in failed state, the system will continue to operate as long as the backup unit has not failed. If the primary unit is restored before the back-up unit fails, then from the operational perspective no

unplanned shutdown situation arises. Standby systems are generally much more reliable than the active redundant systems. In the case of a parallel or redundant system, system failure will only happen when all of the redundant systems have failed. If one or more of the units are operational, the system continues to operate. Generally, in a complex system, standby or redundancy features are designed to take 100% load of the production. If in both of these configurations, the primary failed equipment is not restored before the operating equipment fails, then the system will enter into an unplanned shutdown state. This situation is modeled as Case I and the corresponding state space diagram is shown in Figure 3-7. In Figure 3-7,  $\lambda$  and  $\mu$  represents the transition rate for different system states.

Applying the Markov method to the state space diagram, system availability can be calculated as follows:

$$A = 1 - Q \quad (3-4)$$

where

$$Q = P_3 + P_4 \quad (3-5)$$

where,  $P_3$  and  $P_4$  represents system in unplanned shutdown mode and in planned shutdown mode.

For simplicity, it is assumed that  $\mu_1 = \mu_2 = \mu_3 = R$ , then the system availability (A) and unavailability (Q) can be defined as:

$$Q = \frac{\lambda_1 \lambda_2}{(\lambda_2 + R)(\lambda_1 + \lambda_3 + R)} + \frac{\lambda_3}{(\lambda_1 + \lambda_3 + R)} \quad (3-6)$$

Assuming that in an ideal case, failure rate is higher in the degraded as compared to the normal operation, Eq. (3-7) can be simplified as,

$$\lambda_1 = (\lambda_3 - \lambda_2) \quad (3-7)$$

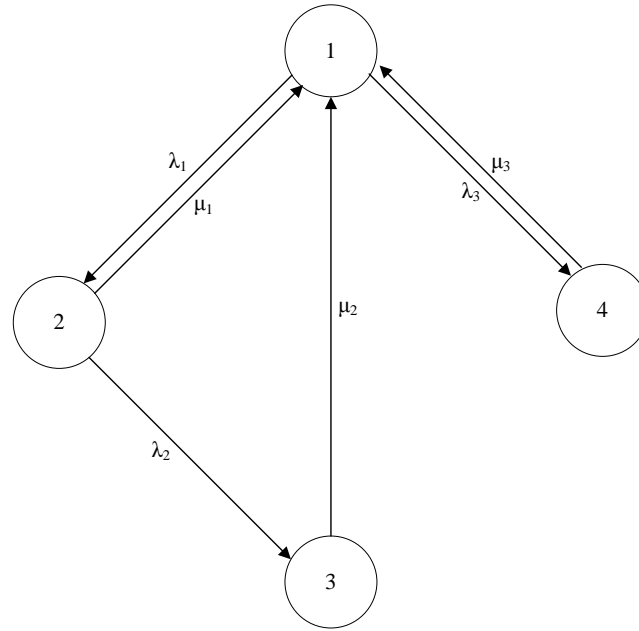

Figure 3-7: State space diagram of an unplanned and planned shutdown for system with redundancy

State	System condition
1	System in operation mode
2	System in operation mode with back-up unit
3	System in unplanned shutdown mode
4	System in planned shutdown mode

and thus, the expression for Q gets modified as:

$$Q = \frac{(\lambda_3 - \lambda_2)(\lambda_2 + R)\lambda_2 + \lambda_3(\lambda_2 + R)}{(\lambda_2 + R)(2\lambda_3 - \lambda_2 + R)} \quad (3-8)$$



### 3.2.2.2 Case II

Another possible scenario is that the systems are designed with no redundancy or standby. In this situation a failure of any equipment or component will lead to unplanned shutdown. Figure 3-8 shows the state space diagram for this type of a system configuration.

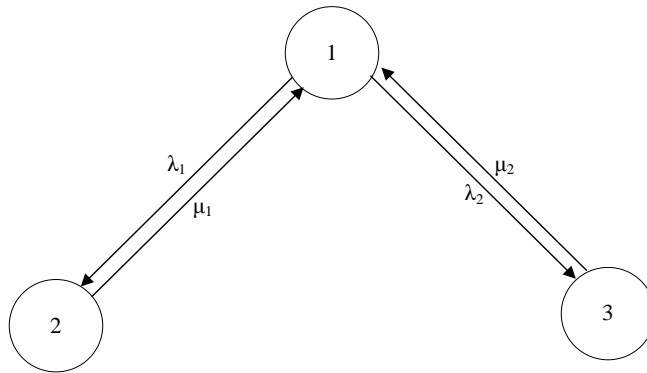

Figure 3-8: State space diagram of an unplanned and planned shutdown for system with no redundancy

State	System condition
1	System in operation mode
2	System in unplanned shutdown mode
3	System in planned shutdown mode

Applying the Markov method to the state space diagram, system unavailability can be calculated as:

$$Q = P_2 + P_3 \quad (3-9)$$

$$Q = \left( \frac{\lambda_1 R_2}{R_1 R_2 + \lambda_1 R_2 + \lambda_2 R_1} \right) + \left( \frac{\lambda_2 R_1}{R_1 R_2 + \lambda_1 R_2 + \lambda_2 R_1} \right) \quad (3-10)$$

$$Q = \left( \frac{\lambda_1 R_2 + \lambda_2 R_1}{R_1 R_2 + \lambda_1 R_2 + \lambda_2 R_1} \right) \quad (3-11)$$

where  $Q$  is the system unavailability. The availability of the system can be calculated using Eq. (3-4).

### 3.2.2.3 System Failure Rate

A complex system may fail through various means resulting from different physical phenomena or different failure characteristics of individual components which may lead to an unplanned shutdown. A useful analysis approach in reliability engineering is to separate these failures according to the mechanism or components causing the failure. These categories of failures are then referred to as failure modes. Ebeling (1997) has defined that if  $\lambda_i(t)$  be the failure rate function for the  $i$ th failure mode then, assuming independence among the failure modes, the system failure rate is obtained as:

$$\lambda = \lambda_{\text{sys}}(t) = \sum_{i=1}^n \lambda_i(t) \quad (3-12)$$

In case of a series-parallel combined system, the system failure rate can be calculated by breaking the network into series and parallel configurations. Mannan (2005) reported that if the failure rate of a component is constant,  $\lambda$ , then in the parallel configuration, the failure rate can be estimated using Eq. (3-13):

$$\lambda_{PC} = \frac{1}{\sum_{j=1}^k \frac{1}{j\lambda_j}} \quad (3-13)$$

Overall system failure rate for series-parallel configuration may be obtained by Eq. (3-14):

$$\lambda = \lambda_{sys}(t) = \sum \left( \sum_{i=1}^n \lambda_{SC} , \sum_{l=1}^m \lambda_{PC} \right) \quad (3-14)$$

where, the term  $\sum_{i=1}^n \lambda_{SC}$  represents the failure rate of the components acting in series and  $\sum_{l=1}^m \lambda_{PC}$  represents the failure rate of the parallel configuration..

### 3.2.2.4 System Repair Rate

System repair time is generally represented as the function of the repair times of the components. An average (mean) system repair time can be calculated by using the knowledge of the mean subsystem or component repair time. For a complex system comprising many subsystems or components, the mean time to repair depends on the repair time distribution of each of the subsystems or components such as electrical, hydraulic, mechanical and so on. Ebeling (1997) defined that the system mean time to repair (MTTR) may be computed as a weighted average of the subsystem MTTRs in which the weights are based on the relative number of failures and can be represented as:

$$MTTR_{sys}(t) = \frac{\sum_{i=1}^n q_i f_i MTTR_i}{\sum_{i=1}^n q_i f_i} \quad (3-15)$$

where  $MTTR_i$  is the mean time to repair the  $i$ th unique subsystem,  $f_i$  is the expected number of failures of the  $i$ th unique subsystem over the system design life, and  $q_i$  is the number of identical subsystems of type  $i$ .

### 3.2.3 Module III – Risk-Based Shutdown Interval Estimation

Muhlbauer (2004) presented the most commonly accepted definition of risk, often expressed mathematically as:

$$\text{RISK}_e = \text{Event Likely hood} \times \text{Event Consequence}, \quad (3-16)$$

However, in this paper, risk is defined as the POF of a system or component to deliver its intended function in a given time-frame under a given operating context and the overall consequences in monetary (\$) values. The two components of the risk can be quantitatively expressed as:

$$\text{RISK}_e = (F_{\text{sys}}(t)) \times \sum \text{Economic Consequence of shutdown } (\$), \quad (3-17)$$

Since the risk is a combination of probability and the consequence, one needs to consider all possible consequences, including safety and health, operational and non-operational consequences. Estimation of failure probability and the consequences are discussed below.

### 3.2.3.1 Estimation of System Failure Probability

In general, operating companies keenly focus on targeting to maintain the desired availability to achieve their operational goal. Considering the process plant targeted availability, and using this as a constraint in the Markov model (as discussed in Case I and II), system failure rate can be estimated. This planned failure rate will help to achieve the required availability of the unit or plant and minimize the overall exposure of the risk to operating companies. Since the system failure probability is a function of failure rate and is complementary to the reliability of the system, mathematically it can be written as:

$$F_{\text{sys}}(t) = 1 - R_{\text{sys}}(t) = \Pr \{T < t\} \quad (3-18)$$

where  $t$  is the failure time of the system on or before a time  $T \leq t$

### **3.2.3.2 Estimation of the Economic Consequences of Shutdown**

Generally, process plants run under extreme operating conditions such as high pressures and temperatures. Improper inspection and maintenance of processing equipment may result in damage to the casing, ring, impeller, and mechanical seal of rotating equipment. These in turn can lead to failure modes which can have a severe impact on the safety and health of the people. For example, a catastrophic failure of a pump bearing operating in a gas processing plant or refinery may release hydrocarbons, which may form a vapor cloud and result in an explosion in the presence of an ignition source. The consequences of a failure are not only localized to mechanical damage of the equipment itself; it can cause significant damages to nearby assets, as well as result in operational loss, serious safety and health issues, adverse environmental impact and inspection and maintenance cost. These consequences can be calculated based on the effects of thermal radiation and overpressure on surrounding equipment and personnel and subsequently converted in monetary (\$) terms. Each of these economic consequences is discussed briefly in the following section.

#### **3.2.3.2.1 Economic Consequence of Asset Loss (ECAL)**

A failure of processing equipment may lead to various hazards resulting from the release of materials and energy. For example, a hydrocarbon release may result in flash fires, jet fires, pool fires, BLEVE, fire balls, VCE or toxic dispersion in a process plant. Consequence effect zones ( $m^2$ ) for such hazards can be calculated in terms of overpressure to establish asset losses. The assessment of the consequence effect zones and their impact involves many models. These include source models, dispersion models, fire models and

explosion models. A large number of computer software packages are available to perform these types of analyses. The main parameters required to perform these calculations are operating pressure, temperature, physical and chemical properties, and atmospheric conditions. In cases of flash fire, jet fire, pool fire and BLEVE, asset damage due to heat flux can be calculated and converted into POF of various damage effects using the probit analysis ((Assael & Kakosimos, 2010), & (Crowl & Louvar, 2002)). Asset damage can be estimated for each accident scenario using the following equation:

$$(ECAL)_i = (PDHF)_i \times AD \quad (3-19)$$

where, *i* represents the various possible scenarios, PDHF is the probability of damage due to heatflux in the effected zones and AD is the asset density.

In the case of explosion, asset damage due to overpressure can be calculated and converted into POF due to overpressure using the probit analysis ((Assael & Kakosimos, 2010), & (Crowl & Louvar, 2002)). Asset damage can be estimated for this scenario using the following equation:

$$ECAL = PDOP \times EZ \times AD \quad (3-20)$$

where PDOP is the probability of damage due to overpressure, EZ is the effected zone due to overpressure and AD is asset density.

### 3.2.3.2.2 Economic Consequence of Human Health Loss (ECHHL)

In cases of flash fire, jet fire, pool fire and BLEVE, probability of injury or death due to fire effects can be calculated for a given heat flux at a specified effected zone and which can be converted into probability of injury or death using the probit analysis ((Assael &

Kakosimos, 2010), & (Crowl & Louvar, 2002)). ECHHL can be estimated for each accident scenario using the following equation:

$$(ECHHL)_i = (PIHF)_i \times PD \times CF \quad (3-21)$$

where, *i* represents the various possible scenarios, PIHF is the probability of injury or death due to heatflux in the effected zones , PD is the population density and CF is the cost of injury or fatality.

In the case of explosion, human health losses such as injuries and fatalities due to overpressure can be calculated and converted into probability of damage due to overpressure using the probit analysis ((Assael & Kakosimos, 2010), & (Crowl & Louvar, 2002)). Economic consequence of human health loss can be estimated for each accident scenario using the following equation:

$$ECHHL = PDOP \times EZ \times PD \times CF. \quad (3-22)$$

where, PDOP is the probability of damage due to overpressure, EZ is the effected zone due to overpressure, PD is population density and CF is cost of injury or fatality.

The loss of life or pain suffered due to equipment failure is difficult to calculate in monetary value. However, the cost due to compensation and corporate liability needs be taken into account in terms of economic consequences, which vary for operating companies. Judycki (1994) of the US Department of Transportation and the Federal Highway Administration published a technical note relating the injury scale (in terms of severity) to the comprehensive costs in police-reported crashes. The figures of this study are used herein to calculate financial impact on companies for human fatality or injuries.

### 3.2.3.2.3 Production Loss

One of the most important operational consequences is the production loss due to unavailability of the asset to perform its function. Production loss due to plant being taken into a planned shutdown is one of the major negative financial impacts on the operating companies. The loss due to the non-production of the desired product is directly linked to the inspection and maintenance duration and frequency over the life of the asset. Production loss is the function of the number of unit loss, selling price/unit and the amount of duration the system is out for inspection and service. In general, the reported MTTR does not cover all the factors which contribute in getting the actual repair duration. To overcome this shortfall and to have a better estimation of the production loss, in this paper a Mean Shutdown Time ( $M_{SDT}$ ) is proposed over the design life of the system or unit considering that the shutdown is a planned event in advance and the factors related to material supply delay and any uncertainty in supply are negligible.

It can be defined as:

$$\overline{M_{SDT}} = \frac{m(t_d)MTTR + \left(\frac{t_d}{T_{SD}}\right)MSDT}{m(t_d) + \frac{t_d}{T_{SD}}} \quad (3-23)$$

where,

MTTR is the mean time to repair,  $t_d$  is design life of the plant or unit,  $T_{SD}$  is shutdown interval and MSDT is Shutdown duration considering preparation, inspection and maintenance actions.

In the case of exponential distribution,  $m$  is replaced with  $\lambda_{sys}$ .

Hence, the operational consequence due to production loss can be represented mathematically as:



$$ECPL = \overline{M_{SDT}} \times PL \times SP , \quad (3-24)$$

where,  $\overline{M_{SDT}}$  denotes the mean shutdown maintenance time in days,  $PL$  is production loss volume per day and  $SP$  is the selling price of the product per unit volume.

#### 3.2.3.2.4 Inspection and Maintenance Cost

Planned inspection and maintenance cost can be classified as a nonoperational consequence. This cost includes the cost of preparation (scaffolding, insulation removal, blinding, purging), cost of inspection (visual inspection, hydro jetting, eddy current testing, etc.) and the cost of maintenance activities and materials (spare parts, maintenance materials, tools and vehicles associated with maintenance or inspection jobs), and the cost of technical support. These costs can be calculated using the following equations:

$$C_p = C_{lp} \times t_p, \quad (3-25)$$

$$C_i = C_{li} \times t_i + C_{ie} \times t_i, \quad (3-26)$$

$$C_m = C_{lm} \times t_m + C_{sp}, \quad (3-27)$$

$$C_{ts} = C_{lts} \times t_{ts}, \quad (3-28)$$

$$ECSIM = C_p + C_i + C_m + C_{ts}. \quad (3-29)$$

Where,  $C_p$  is the preparatory cost,  $C_{lp}$  is the cost of preparatory maintenance labor per hour (\$/Hr.),  $t_p$  is the duration of the preparatory work,  $C_i$  is the inspection cost,  $C_{li}$  is the cost of skilled inspection labor per hour (\$/Hr.),  $C_{ie}$  is cost of inspection equipment per hour (\$/Hr.),  $t_i$  is the duration of inspection work,  $C_m$  is the maintenance cost,  $C_{lm}$  is the cost of skilled maintenance labor per hour (\$/Hr.),  $C_{sp}$  is the cost of spare parts consumed,  $t_m$  is the

duration of maintenance work,  $C_{ts}$  is the technical support cost,  $C_{lts}$  is the cost of a technical support specialist per hour (\$/Hr.) and  $t$  is the duration of technical support work in hours.

The total economic consequences of shutdown are the following:

$$EC_T = Max (ECAL + ECHHL)_i + \sum_{i=1}^n ECSIM + ECPL, \quad (3-30)$$

where,  $i = 1, 2, 3, \dots, n$  is the equipment identified from the criticality matrix and considered for shutdown interval estimation.

A risk-based approach not only helps to make an optimized decision to bring a process plant or unit in a shutdown mode for inspection and maintenance but also assists in determining an optimized shutdown inspection and maintenance interval. The concept of risk-based inspection and maintenance optimization is generally accepted and applied in petrochemical and process industries. However, it has not been used to optimize the shutdown inspection and maintenance interval.

### 3.3 The Application of RBSIM to a LNG Processing Facility

Alabdulkarem et al. (2011) have reported that LNG plants are increasing in number due to the growing demand for natural gas (NG). NG is the cleanest of the fossil fuels. LNG is produced by the liquefaction of NG from the atmospheric temperature to  $-160^\circ\text{C}$ . Different NG liquefaction cycles exist that use either pure refrigerant in cascade cycles, multi-pressure cycles, or mixed refrigerant (MR) cycles. Mokhateb and Economides (2006) reported that the Air Products and Chemicals, Inc. (APCI) licensed Propane Precooled MR process has dominated the market since 1970 and accounts for a significant proportion of the world's base load LNG production capacity.

Alabdulkarem et al. (2011) reported that about 77% of LNG plants are using the propane pre-cooled MultiComponent Refrigerant cycle licensed by APCI for NG liquefaction. Roberts et al. (2002) reported that in response to continuing producer demand for increased LNG train capacity, APCI has developed the AP-X<sup>TM</sup> LNG Process. The AP-X<sup>TM</sup> process is a hybrid of a C3-MR cycle for precooling and liquefying LNG and a nitrogen gas compressor-expander cycle for subcooling LNG. In the AP-X<sup>TM</sup> process, the warmer LNG is subcooled to storage temperature by a gaseous nitrogen refrigerant in the same compression/expansion cycle that has been used for years to liquefy oxygen, nitrogen, and for peak-shaver NG liquefiers. Similar to the traditional C3MR process, propane is used to provide cooling to a temperature of approximately -30 °C. The feed is then cooled and liquefied by MR, exiting the Main Cryogenic Heat Exchanger (MCHE) at a temperature of approximately -120 °C. Final subcooling of the LNG is performed using cold gaseous nitrogen from the nitrogen expander. The proposed methodology is applied to a LNG facility. Figure 3-9 shows a general equipment layout for the liquefaction and subcooling sections of an AP-X<sup>TM</sup> LNG train. Coil wound heat exchangers are used to liquefy and subcool the LNG, while the nitrogen economizer uses brazed aluminum plate fin heat exchangers.

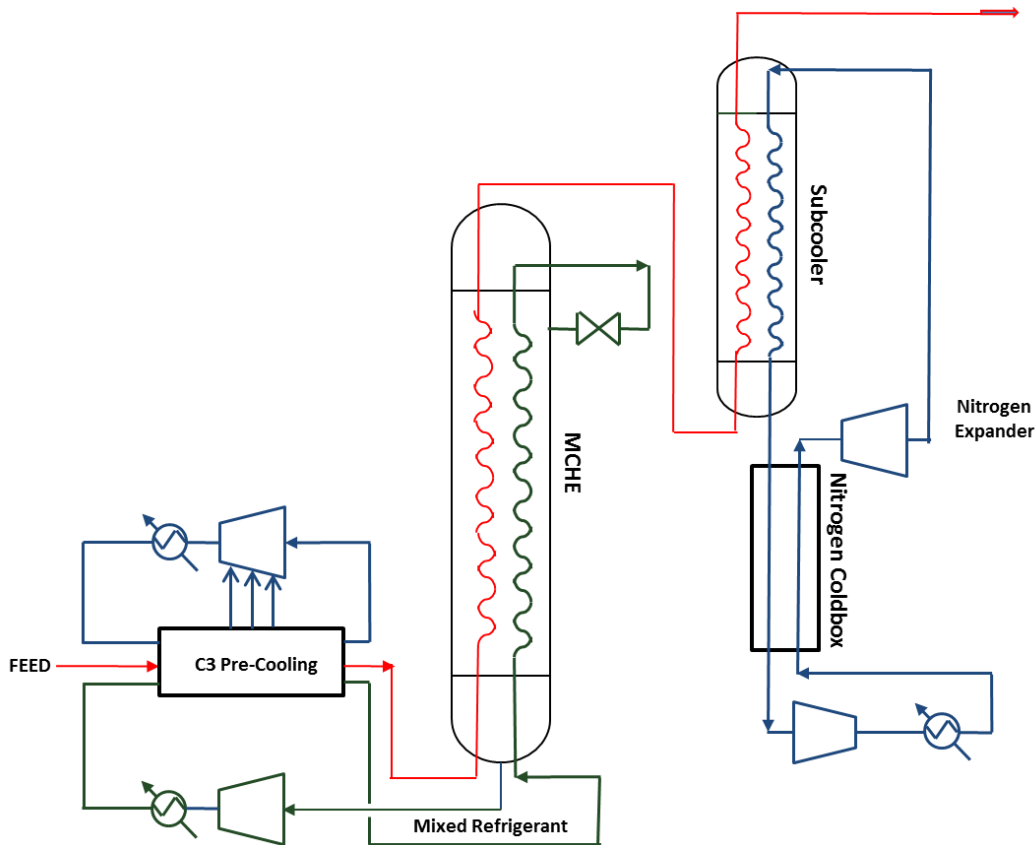

Figure 3-9: Air Products AP-X™ process (redrawn after Roberts et al. 2002)

The described methodology can be extended to other production processes as well. However, the risk matrix should be re-evaluated accordingly for equipment selection.

### 3.3.1 Module I: Risk-based Selection of Critical Equipment

In this application, the methodology discussed earlier is applied to a section of the refrigeration unit of one of the LNG liquefaction processing plants. The main purpose of the refrigeration unit in a liquefaction processing plant is to supply various refrigerants to condense the NG into LNG. As a by-product, the exhaust gas from the gas turbine is routed through a heat recovery system where high pressure steam is produced. The refrigeration unit

is composed of three major systems viz., the propane refrigeration system, the MR system and the nitrogen refrigeration system. The propane system primarily provides chilling for the feed circuit and the MR system. The MR system provides low temperature refrigeration to produce LNG in the MCHE. Finally the nitrogen system subcools the LNG in the Sub-cooling Heat Exchanger. The propane refrigeration system consists of propane compression, water-cooled condensers and subcoolers. The heart of the system is a gas turbine with a starter, helper and/or generator which drives the compressors. The MR comprises a mixture of hydrocarbon (methane, ethane and propane) and nitrogen. The system is composed of a numbers (varies design-wise) of compressors, turbine, water cooled and propane cooled heat exchangers, suction drums and separators. The nitrogen refrigeration system consists of compressor, water-cooled inter-coolers and exchangers. Equipment criticality analysis helps to evaluate how failures of these equipment impact the performance of assets and is used to prioritize equipment selection for inspection and maintenance. Module I of the presented methodology describes the critical equipment selection using the risk matrix. The proposed risk assessment not only helps to evaluate and select the critical equipment for shutdown inspection and maintenance availability modeling (by considering its influence on the plant or unit) but also to determine the risk associated if the inspection and maintenance interval cycle is delayed beyond the manageable duration. Equipment categorization using this methodology helps to identify the critical equipment and their interaction for unit or plant availability. The outcome of this qualitative risk evaluation is the classification of the equipment with a risk prioritization number. For example, if an equipment is identified having as high probability (frequent = 5) and higher production loss (extreme= 5), the risk number is 25. Similarly the other risk factors can be estimated. In the case of multiple risk

numbers, the higher risk number is considered for the equipment. This process is continued until all of the equipment in the unit is evaluated. In case, if the POF is low but has a higher consequence impact on HSE, the equipment is selected as critical. The selected critical equipment is used to develop the functional block diagram to model the shutdown availability. The block diagram helps to select the best Markov model for system availability estimation. A total of 12 equipment are identified to be critical for the considered unit which can have a severe financial impact on the operability of the unit. These equipment are listed in Table 3-3. The block diagram is shown in Figure 3-10, which is based on the selected equipment.

Table 3-3: Critical selected equipment for MR unit

<b>Tag</b>	<b>Equipment description</b>
MR1	Accumulator
LSD1	Suction Drum
LC1	Compressor
LPA1	Compressor After-cooler
MSD1	Suction Drum
MC1	Compressor
MPA1	Compressor After-cooler
HSD1	Suction Drum
HC1	Compressor
HPA1	Compressor After-cooler
GT1	Gas Turbine
HM1	Starter/Helper/Generator Motor

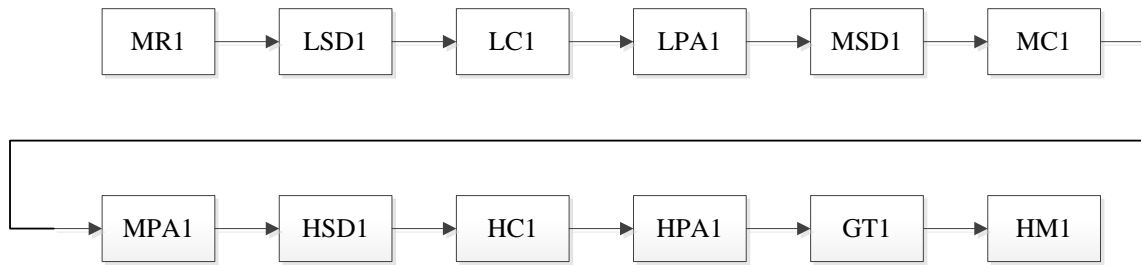

Figure 3-10: Block diagram of critical selected equipment for MR unit

### 3.3.2 Module II: System Availability Modeling using Markov Process

The developed block diagram in Module I will help to select the Markov model to estimate the planned system failure rate for inspection and maintenance under the considered availability constraint. It is evident from the block diagram that a failure of any of the selected equipment will lead to complete system failure which will produce an undesired shutdown of the plant. Thus, any inspection and maintenance plan should consider these critical equipment to perform a risk-based shutdown inspection and maintenance interval. In order to estimate the planned shutdown failure rate considering the required unit availability, failure rate and repair rate data are of primary importance. Failure and repair rates of a system are primarily determined using plant historical data, test data, data banks, and/or from the operating experience of plant personnel using expert judgment. In case if failure specific data are not available, theoretical approaches published by Cizelj et al. (2001) can also be used. For this study, failure and repair data for the selected critical equipment are either adopted from the OREDA (2002) or help has been sought from qualified plant personnel based on their technical judgment for repair data. Table 3-4 shows the failure rate and repair rate data considered for this study. Eq. (3-8) and Eq. (3-11) of the proposed Markov model

discussed in Module II are used to estimate the system planned shutdown failure rate which will help to achieve the desired availability target. The estimated value is shown in Table 3-5.

Table 3-4: Critical selected equipment failure and repair data

<b>Equipment description</b>	<b>Failure rate (<math>\lambda</math>)</b>	<b>Repair rate (<math>\mu</math>)</b>
Accumulator	$1.141 \times 10^{-6}$	0.0208
Suction Drum	$1.141 \times 10^{-6}$	0.0208
Compressor	$2.314 \times 10^{-6}$	0.0027
Compressor After-cooler	$1.141 \times 10^{-6}$	0.0208
Gas Turbine	$2.283 \times 10^{-5}$	0.0208
Starter/Helper/Generator Motor	$3.805 \times 10^{-6}$	0.0138

Table 3-5: Estimated system failure and repair rates

Availability Constraints	0.98	
Estimated system failure rate	$4.157 \times 10^{-5}$	Using Eq. (3-12)
Estimated system repair rate	0.0097	Using Eq. (3-13)
Estimated planned shutdown failure rate	0.00016	Using Eq. (3-9)

### 3.3.3 Module III: Risk-Based Shutdown Interval

Module III of the proposed methodology consists of three parts viz. estimating system failure probability, all possible consequences due to process unit shutdown, and finally developing a risk profile to find the optimal shutdown inspection and maintenance interval. A system failure probability is a function of time and failure rate, which can be modeled using



exponential, Weibull, normal or lognormal distribution. In order to apply Markov availability model system failure probability is calculated using the exponential distribution as discussed in Module II. The estimated value of exponential distribution parameter is shown in Table 3-5. Thus, the system failure probability function can be written using Eq. (3-17) as follows:

$$F_{sys}(t) = 1 - \exp(-0.00016t) \quad (3-31)$$

Given the fact that the equipment described here involves the processing of hydrocarbons and operates at extreme conditions, the consequences of any failure will be very high. The failure scenario considered for estimating the asset loss and human health loss for these equipment is the release of hydrocarbons, which upon finding an ignition source may result in explosion that could generate shock waves. These shock waves may cause serious asset damage as well as human injuries or fatality. Calculated shock waves are then transformed into probability of damage due to shock waves for various effected zones. In this particular scenario, estimated consequence is based on a radius of 200m. It is important to note that the loss of life or injury suffered by the people is hard to estimate in monetary value. However, the cost associated with the compensation and corporate liability needs to be taken into account in consequence analysis. In this regard, a published note from Judycki (1994) of the US Department of Transportation and the Federal Highway Administration relating the injury scale (in terms of severity) to the comprehensive costs in police-reported crashes is used. Production loss is estimated using Eq. (3-23), and an average of 10 days is considered for MSDT. The U.S. Energy Information Administration (2012) published the LNG price in \$/thousand cubic feet. The same is used in this study to calculate the economic consequences of production loss. The total calculated consequence along with Eq. (3-29) is

used to generate the expected risk profile to determine the optimal inspection and maintenance intervals. Figure 3-11, shows the obtained risk profile to achieve the optimal planned shutdown inspection and maintenance interval. This risk profile will enable the achievement of a desired level of availability (98%) for the system considered while meeting the risk exposure to the lowest level. The lowest risk point will give an optimum shutdown interval; in this case it is estimated to be 13000 h. It is evident that by performing a risk-based planned shutdown inspection and maintenance interval, the risk will be significantly reduced. As the shutdown interval beyond this period (the time at which the system needs to be down for inspection and maintenance) increases, the risk starts to increase as shown in Figure 3-11. Risk profile obtained is a function of system failure, and system configuration coupled with exposed consequences to the operation due to unavailability of the facility. Hence, depending upon the company risk tolerance, estimated shutdown interval for the considered unit can be further increased. A sensitivity analysis is performed to study the effect of the availability constraint and mean shutdown inspection and maintenance duration on the shutdown interval model. The results are plotted in Figure 3-12 and Figure 3-13. It is evident from Figure 3-12 that the estimated shutdown inspection and maintenance interval is sensitive to the overall system availability considered. For 95% system availability, the estimated interval is close to 19000 h. for 97% system availability the estimated interval is close to 16000 h., and for 98% system availability the estimated interval is close to 13000 h. No significant impact is observed for the mean shutdown time duration over the shutdown inspection and maintenance interval. Based on risk-based shutdown interval estimation, for the design life of 25 years, a total of 17 shutdowns are recommended. This is the optimal number of shutdown over the design life. However, if an inspection and maintenance strategy

is selected based on individual equipment basis, it will be suboptimal and will have higher financial risk (as evident in Figure 3-12).

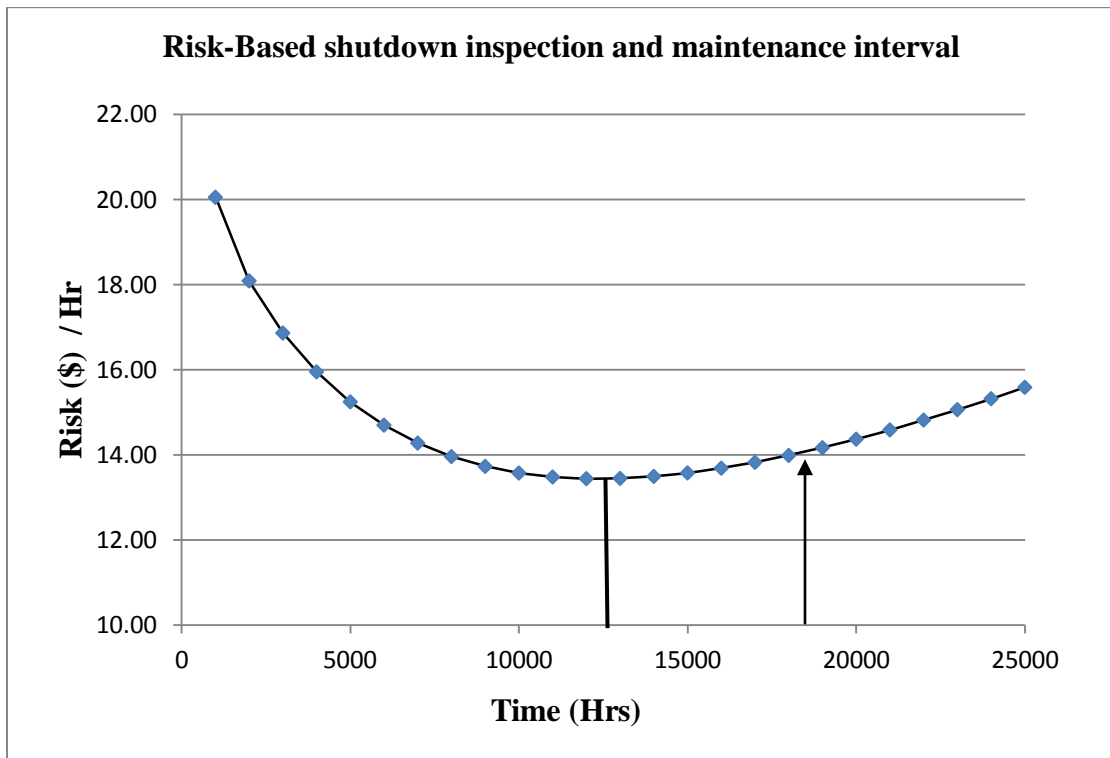

Figure 3-11: Risk-based shutdown inspection and maintenance interval modeling

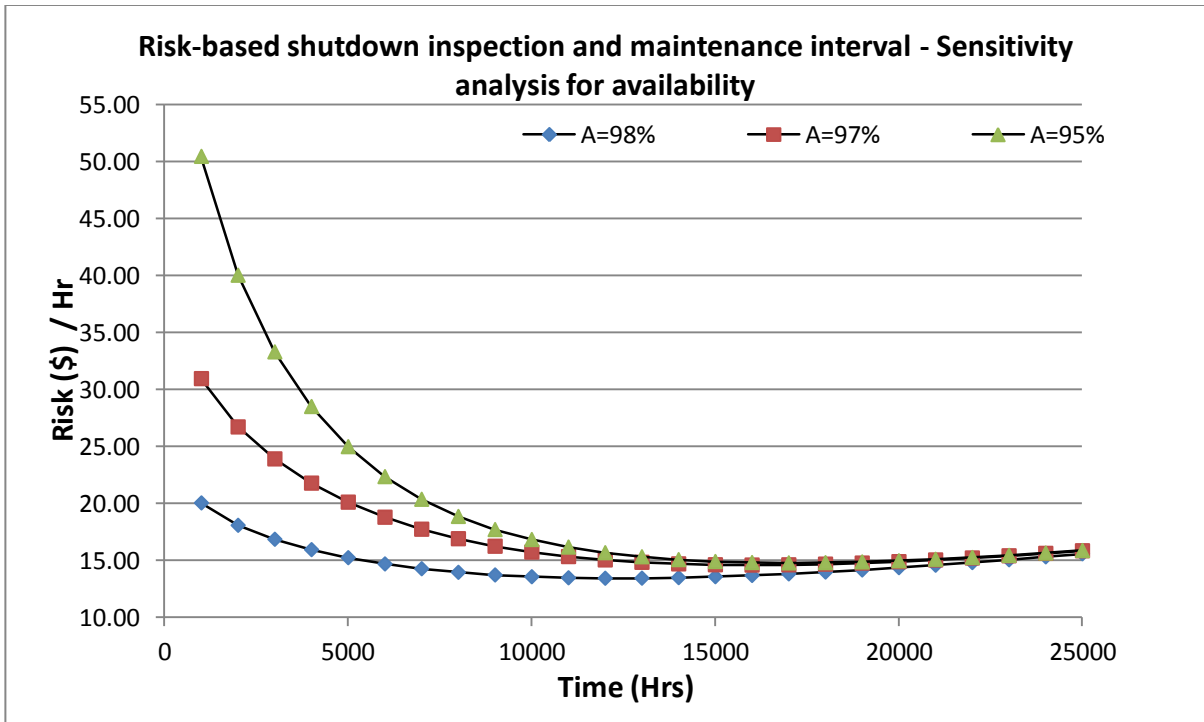

Figure 3-12: Risk-based shutdown inspection and maintenance interval – Sensitivity analysis for availability

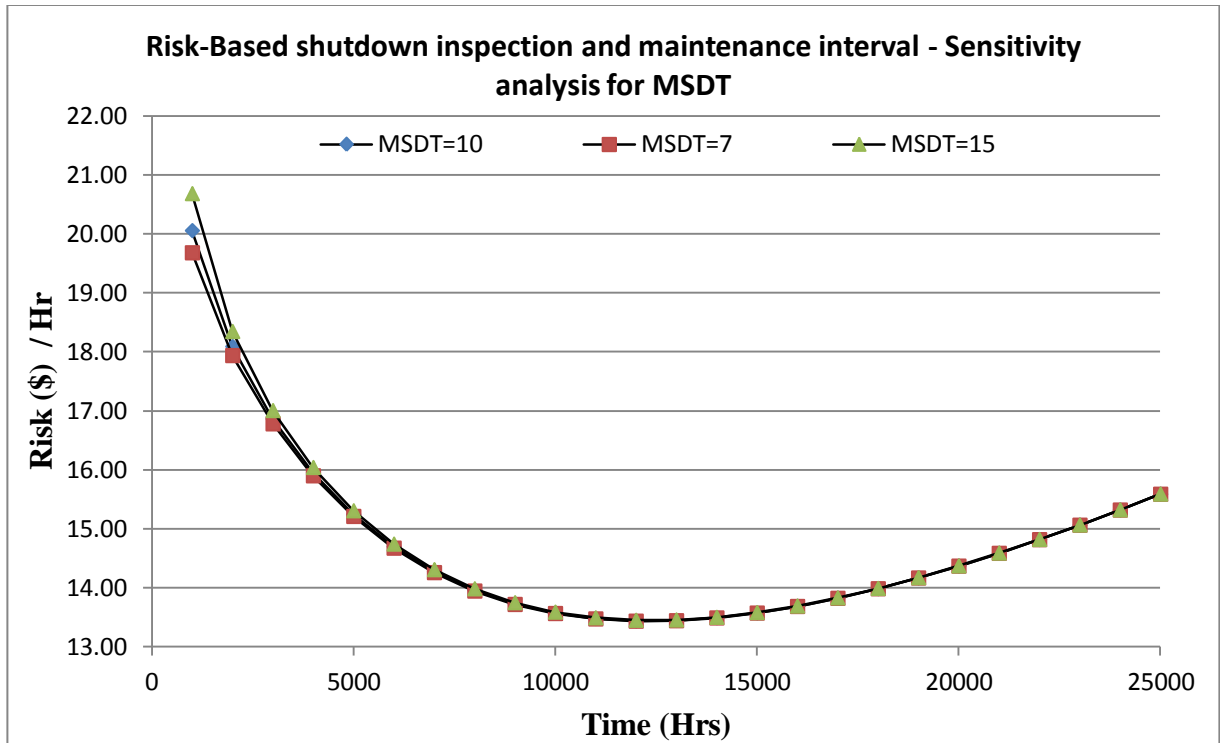

Figure 3-13: Risk-based shutdown inspection and maintenance interval - Sensitivity analysis for MSDT

### 3.4 Discussion and Conclusions

Over the last few decades risk-based inspection and maintenance optimization has been accepted and applied in petrochemical and process industries. However, in most cases it has been applied to optimize the inspection and maintenance interval on equipment basis. In addition, there is lack of system's approach to estimating risk-based shutdown inspection and maintenance interval. In this article a methodology to estimate the shutdown inspection and maintenance interval considering system availability using Markov process is presented to

reduce the exposure of risk to the operating company and shareholders. This methodology ensures that the unit or plant is not only available for production but also the overall risk exposure is reduced to an acceptable level. Estimated risk-based shutdown inspection and maintenance interval will not only enhance the reliability and availability but also the safety and operation of the facility. The methodology provides a tool to determine shutdown inspection and maintenance intervals for unit or systems based on the optimization of the total risk in order to bring the operating plant in a planned shutdown mode. The presented methodology consists of three main modules: (1) Risk-based critical equipment selection, (2) Shutdown availability modeling using Markov process, and (3) Risk-based shutdown interval estimation. The proposed methodology minimizes the financial consequences for an operating company due to production loss, loss of assets, safety (e.g., injury or loss of life).

In the present study, the proposed methodology is applied to the MR section of a LNG refrigeration unit, ensuring that the high level of risk is contained at an acceptable level. The developed risk-matrix is used to select the critical equipment that cannot be inspected or maintained without the unit or plant being taken into shutdown. Applying the Markov process, an availability constraint of 98% is used to estimate the planned shutdown rate. Estimated planned shutdown failure rate along with the consequences of failures are used to generate the risk profile as shown in Figure 3-11. Risk-based shutdown interval optimization approach is expected to provide a cost-effective maintenance and inspection program and provide better asset and capital utilization. All processing plants such as LNG processing facilities, petrochemicals and refineries, which consist of similar equipment like heat exchangers, vessels, columns, compressors, pumps, turbines, valves, detectors, transmitters and others can benefit immensely from this approach. The functionality of these equipment

remains the same, except that their operating parameters can vary. Moreover, since the shutdown availability modeling is only dependent upon the failure rate and the repair rate and other assumptions do not play a significant role, the presented methodology can be extended to any processing or manufacturing facility. However due care should be exercised when defining the risk-matrix for selecting critical equipment which requires the unit or plant to be taken in shutdown in order to perform any inspection and maintenance.

## Chapter 4

### **A risk-based shutdown inspection and maintenance interval considering human error for a processing facility <sup>3</sup>**

#### **Abstract**

This paper presents a risk-based methodology to estimate shutdown inspection and maintenance interval by integrating human errors with degradation modeling of a processing unit. The methodology presented in this paper addresses to identify number of shutdown intervals required to achieve a target reliability over a goal period. The proposed methodology is the extension of the previously published work by the authors to determine the shutdown interval considering the system desired availability. The proposed work is novel in the sense that a concept of human error during shutdown inspection and maintenance is introduced while modeling the system failure. Selection of critical equipment is the most important aspect in obtaining the shutdown interval to minimize overall operational risk. In order to achieve this; a risk criticality matrix is proposed to select the

---

<sup>3</sup> *This Chapter is based on the published work in a peer-reviewed journal. Abdul Hameed, Faisal Khan, Salim Ahmed (2016), "A Risk-based Shutdown Inspection and Maintenance Interval considering human error for a processing facility," Process Safety and Environmental Protection, Volume 100, pages 9-21. To minimize the duplication, all the references are listed in the reference list. The contribution of the authors is presented in Section titled, "Co-authorship Statement".*



critical equipment for shutdown inspection and maintenance. Probability of human error induced during shutdown inspection and maintenance is estimated using Success Likelihood methodology (SLIM). The proposed methodology is comprised of three steps namely, equipment selection considering criticality of operation, system failure modeling considering human error and finally a risk-based shutdown inspection and maintenance interval estimation. The proposed methodology is applied to a gas chilling and liquefaction unit of a hydrocarbon processing facility. The methodology is used to ensure the practicality of the proposed formulation to the real industry. The proposed methodology can be applied to any plant (process or non-process) such as those for LNG processing, petrochemicals, refineries or manufacturing plants. The key elements for the success of the proposed methodology are the identification and selection of critical equipment, breakdown of activities to estimate human error probability (HEP) and plant specific data for modeling system failures.

## **4.1 Introduction**

Due to continuous production demands, processing facilities are getting not only bigger and bigger but also more complex in nature. The increase in complexity and size is inviting maintenance and reliability engineers to put more emphasis on system inspection and maintenance optimization to minimize unplanned downtime, overall cost and risk exposure. Effective inspection and maintenance is one of the critical elements for operating facilities. The core objective of inspection and maintenance is to make sure that the facilities or equipment are optimized in a way, which does not only increase the reliability and availability of the plant but also minimizes the overall operational risk. Inspection and maintenance on some of the equipment are performed by taking the unit or facility out of the

service, generally termed as Shutdown. Taking the unit or facility out of the service, generally termed as shutdown, performs inspection and maintenance on some of the equipment. Duffua and Daya (2004) and Lawrence (2012) have stated that a planned periodic shut down is carried out to perform maintenance and to inspect, test and replace process materials and equipment. Inspection and maintenance strategies of the equipment, which do not require facility to be taken in shutdown mode, can be developed based on individual equipment. Shutdown interval is one of the most important factor in determining an effective inspection and maintenance policy. In case if the shutdown inspection and maintenance interval is too short, facility shutdown time and production loss along with the inspection and maintenance cost will be too high, vice versa if the shutdown interval is too long, the production loss and inspection and maintenance cost will be low but the risk exposure will be high. This leads to find an optimal solution for shutdown inspection and maintenance interval. Failure of equipment may lead to significant consequences due to improper planning. Understanding the facilities system from operation and safety is the most important facet when selecting and designing a shutdown inspection and maintenance model. A typical processing facility consists of hundreds of equipment, which works, in rigorous environment. One of the key aspects which should be covered and included when modeling for shutdown inspection and maintenance optimization, is to include human error and its impact on the equipment or system failure. Integration and design of the systems such as acting in series, parallel, combination of series-parallel, 50% load capacity or 100% load capacity dictate the development of shutdown inspection and maintenance strategy for the processing plant. Inspection and maintenance operation is one of the key links in the process chain for achieving the required production and management goals. While performing

inspection and maintenance, a minor failure and omission in following a clear guideline or process not only minimizes all of the inspection and maintenance benefits but also increases and changes the failure rate or behavior of the equipment or system due to introduction of human error. Despite technological advancement in equipment design and consideration given for maintainability, man-machine interface cannot be eliminated. In general, any inspection and maintenance process involves disassembly; reassembly and/or replacement of components. These processes require human interaction, and under various circumstances, create potential to include human error by installing or replacing a wrong part or assembling the part in wrong sequence despite all technological enhancement. In this paper, the focus is on the group of equipment which cannot be inspected or maintained and requires a shutdown of the facility. Thus, in order to develop an optimal inspection and maintenance strategy, attention must be paid while selecting these critical equipment.

## **4.2 Past Studies**

Inspection and maintenance optimization has gained huge momentum and dynamic changes over the last couple of decades due to the realization of potential benefits in plant availability, reliability, scheduling, cost and risk minimization. Risk, reliability and availability are the three facet of facility operation and are interminably linked together. A high risk is generally an indication of facility lower reliability and availability, while higher availability means higher reliability and lower risk. Operation risk is associated with the probability of equipment or component failure and the consequences of failure such as loss of revenue due to production loss, asset damages, safety and health issues and inspection and maintenance costs. Obiajunwa (2012) reported that typically power plant turnaround

maintenance is planned for every four years, oil refinery and petrochemical plant shutdown maintenance is planned for every two years, and chemical, steel, glass and food and beverage plant shutdown maintenance is planned for every year. Alsyouf (2007) presented a model enabling the decision-makers to identify how an effective maintenance policy could influence the productivity and profitability through its direct impact on quality, efficiency and effectiveness of operation. Backlund and Hanu (2002) reported that while doing the risk analysis focus must be put on the function required of the subsystem and equipment. Fujiyama et al. (2004) proposed a risk-based maintenance system for steam turbine plants which is coupled with an inspection system. Ghosh and Roy (2009), Rusin and Wojaczeck (2012), Vaurio (1995), Khan and Haddara (2003, 2004a,b), Krishnasamy et al. (2005), Tan and Kramer (1997), Duarte et al. (2006) and Vatn et al. (1996) have presented methods to estimate the optimal maintenance and inspection interval considering cost, risk, availability and reliability for individual equipment and have not considered the impact of facility shutdown. Neil and Marquez (2012) proposed a hybrid Bayesian network (HBN) framework to model the availability of renewable systems considering corrective repair time, logistics delay time and scheduled maintenance. These were combined with time- to-failure distributions using HBN. Mannan and Yang (2010) proposed a dynamic risk assessment (DORA) methodology considering various process variables such as level, flow rate, temperature, pressure and chemical concentration and their impact to guide and improve the process design and optimize failure probability. However, the proposed methodology is not considering whether a sequence of component failure will lead to the system failure. The uniqueness of the presented methodology is that it helps to optimize the shutdown inspection and maintenance interval to minimize the overall system failure which will lead to reduce the

un-necessary shutdown. Jacob and Amari (2005) presented a binary decision diagram to calculate system reliability and availability. Pil et al. (2008) proposed a redundancy optimization and maintenance strategies based on a time dependent Markov approach. Khan and Haddara (2003) proposed a comprehensive and quantitative methodology for risk-based maintenance. Dey et al. (1998) and Dey (2001) have applied risk-based approach to the maintenance of oil pipelines. Khan et al. (2008) have presented a risk-based methodology to maximize a system's availability by considering risk-based inspection and maintenance program to reduce the risk of failure and enhance the overall availability of the system. Sarkar and Behra (2012), Bertolini et al. (2009), Kumar and Chaturvedi (2008), Zhaoyang et al. (2011) and Wang et al. (2012) proposed that selecting a maintenance strategy based on risk reduces the overall risk. However, most of these studies are concerned with optimizing equipment inspection and maintenance cycles based on perfect (AGAN) as good as new or minimal (ABAO) as bad as old repair. AGAN strategy holds the assumption that after the maintenance intervention, the system starts its life under the same failure rate as if it were new. On the other hand ABAO holds that the equipment or system is maintained with minor action, which has not changed the failure rate behavior and after the maintenance activity the failure rate remains the same as it was before the maintenance. In order to overcoming the short fall of AGAN or ABAO strategy, researchers have introduced concept of imperfect maintenance. Nguyen and Murthy (1981) introduced the concept of imperfect maintenance considering that the failure characteristic of the system is different (worse) from that of correctively maintained system to minimize the mean cost rate. Block et al. (1985) extended Brown and Proschan model and proposed an age dependent repairable model considering a probability of  $p(t)$  a complete repair or with probability  $q(t)=1-p(t)$  is a minimal repair,

where,  $t$  is the age of the equipment in use at the failure time. Ben-Daya and Alghamdi (2000) presented two sequential preventive maintenance model considering age reduction model, an extension of Nakagawa's model while in the second model PM, intervals are defined such that the integrated hazard rate over each interval is the same for all intervals. Levitin and Lisnianski (1999) have used Genetic Algorithm to generalize a preventive maintenance optimization to multi-state system considering the effective age of equipment. Nakagawa et al. (2012) considered system damages (damage level  $k$ ) due to shock (shock number  $N$ ) and proposed a preventive model considering imperfect maintenance. Rangan and Grace (1989) extended Brown and Proschan model to develop a replacement policy for a deteriorating system with imperfect maintenance. Li and Shaked (2003) extended Brown and Proschan (1983) imperfect maintenance approach to model preventive maintenance and obtained stochastic maintenance comparisons for the number of failures under different policies via a point process approach. Malik (1979) introduces the concept of improvement factor assuming that maintenance action changes the system time of the failure rate curve and the failure rate post maintenance lies between as good as new and as bad as old. Brown and Proschan (1983) reported that some possible causes for imperfect, worse or worst maintenance due to the maintenance performer, such as repair the wrong part, only partially repair the faulty part, repair the faulty part but damage the adjacent part are the true contributor. Nakagawa and Yasui (1987) reported that hidden failures which are not detected during the maintenance, human errors such as wrong adjustment and further damage done during maintenance and replacement with faulty parts. Dhillon (1986) reported that operation, assembly design, inspection, installation and maintenance are all prone to human errors. These errors are due to poorly written maintenance procedures, complex maintenance

tasks, harsh environment, fatigue, outdated maintenance manual, inadequate training and experience. Dhillon and Liu (2006) reported that reasons for the occurrence of human errors including inadequate lighting in the work area, inadequate training or skills of the manpower involved, poor equipment design, high noise level, an inadequate work layout, improper tools and poorly written equipment maintenance and operating procedure. They further classified that human error in six categories, (1) operating error (2) assembly error (3) design error (4) inspection error (5) installation error and (6) maintenance error. Dhillon and Yang (1995) cited that failure of repairable system can occur not only due to hardware failure but also due to operating human error or maintenance error. Factors such as temperature, dust, fatigue, incomplete or inappropriate maintenance tools, errors in inventory and personal problems may be the contributor for these errors. Noroozi et al. (2014, 2013) used Human Error Assessment and Reduction Technique for evaluating human error risk assessment and applied to pre- and post-maintenance procedure of a process facility and has also applied Success Likelihood method (SLIM) to perform human factors analysis in pre- and post-pump maintenance activities for offshore facility. The above referred literature covers inspection and maintenance interval modeling considering cost, reliability, availability and risk, imperfect maintenance and human error. However majority of these have discussed inspection and maintenance based on equipment by equipment basis. In reality, a process plant, a unit or system consists of hundreds of pieces of equipment that run in continuous mode. Further, possible human errors in the inspection and maintenance activities can impact equipment performance. For example, poor repair can play an instrumental role in increasing the number of equipment breakdowns or failure pattern which in turns can significantly increase the risk associated with equipment. Understanding the probability of human error

while performing inspection and maintenance and including in the modeling will provide a better sight to reduce the overall risk and increasing reliability, availability and safety. Developing an inspection and maintenance strategy without considering the impact of these inspection and maintenance due to the shutdown of the plant and the associated risk due to human errors will not produce an optimum interval. This problem could be solved by considering a risk-based critical equipment selection and then by developing an optimized shutdown inspection and maintenance interval considering the imperfectness due to human error for the system or unit. The objective of this paper is to develop a risk-based shutdown inspection and maintenance optimization methodology by integrating HEP in the system failure model for a continuous processing facility. This proposed methodology will provide a rational basis to make a shutdown inspection and maintenance decision making considering human error contribution in inspection and maintenance and the overall risk exposure.

### **4.3 A risk-based inspection and maintenance modeling considering human error**

Although several research have been published on inspection and maintenance interval modeling and optimization in the literature as discussed above, majority of these works deals to address the individual equipment. Consideration of shutdown inspection and maintenance modeling is found to be limited. Hameed et. al (2014) and Hameed and Khan (2014) has proposed a risk-based shutdown interval modeling for continuous operating facilities. These modelings are based on the assumption of the perfect maintenance. In reality majority of the time inspection and maintenance does not meet the perfect conditions and fall short. The result of imperfectness is induced due to the contribution of human error. Errors



induced during inspection and maintenance may be realized immediately and result in the premature failure of the equipment or system or in some cases may lie dormant with the equipment or system for some period of time, until a combination of other factor accelerate the degradation mechanism and lead to a failure. Some-time these have resulted in serious accidents in process industries. The proposed model is developed considering the human error which may be induced during the shutdown inspection and maintenance and is the extension of Hameed et. al (2014) and Hameed and Khan (2014). The objective of this paper is to integrating human errors in the system failure model and to interlink this with the operational risk. Higher the probability of failure of inducing the human error in inspection and maintenance, the degradation or the system failure probability will be more impacted. The proposed shutdown inspection and maintenance methodology is broken down in three modules and shown in Figure 4-1. Assumption in developing the model as well as detail of each module is described below;

#### **4.3.1 Assumptions for Model Development:**

- A group of equipment which cannot be inspected or maintained without taking the plant into non-operational mode (shutdown).
- Failure as time-dependent process.
- Material, labor, specialist, production cost are available.
- The degree of imperfectness is assumed to be a number between 0 and 1 due to human error while performing inspection and maintenance.
- Sufficient manpower and equipment are available to execute the planned job.
- Inspection and maintenance durations are non-negligible.

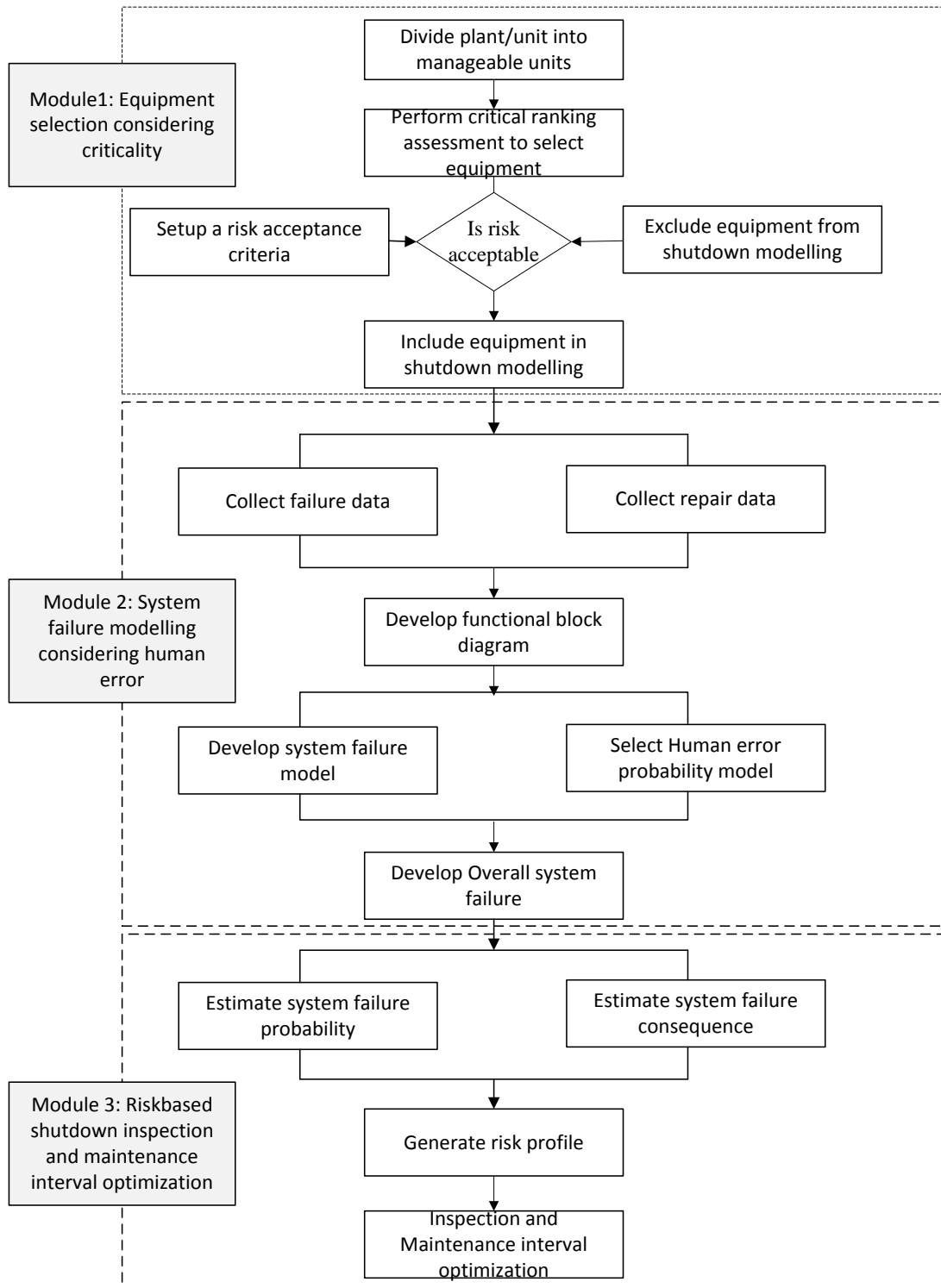

Figure 4-1: A Risk based inspection and maintenance interval optimization model considering human error

### **4.3.2 Module 1: Equipment selection considering criticality of Operation:**

A processing facility consists of a large number of interacting systems or equipment. When these system or equipment performs together the facility delivers its intended function. These systems or equipment are subject to periodically or non-periodically planned inspection and maintenance during its life cycle. The inspection and maintenance management is one of the key decisions for continuously operating plants to improve the plant reliability, availability and integrity. Some of these system or equipment can't be isolated to perform inspection and maintenance, and requires the plant to be taken in shutdown mode. The remaining systems and units do not impact the overall facility operation and can be taken out for inspection and maintenance without causing facility operation shutdown. Thus, it is very critical to identify system or equipment for their inspection and maintenance to minimize the impact due to operation loss and to achieve required reliability and availability. The success to achieve an optimal inspection and maintenance plan for the facility depends on identifying and selecting these critical equipment. In this paper a risk criticality matrix is proposed to select these equipment. The uniqueness of the proposed matrix is to identify these critical equipment and system which will not only help to reduce the utilization of inspection and maintenance resources but also help to increase the reliability and availability of the unit. The process consists of the following steps;

- (1) Developing a boundary diagram by breaking down units or plant into manageable system.

- (2) Reviewing all equipment in the selected boundary using a risk matrix to establish the criticality in relation to the operation of facility, production loss and impact on asset damage. Proposed criticality matrix is shown in Figure 4-2.
- (3) Estimating the qualitative risk criticality number and comparing with the acceptable criteria.
- (4) If the risk number does not meet the acceptable criteria, include the equipment in shutdown inspection and maintenance planning.
- (5) Continue the process until the all equipment in the selected boundary has been analyzed.

The advantage of this qualitative risk assessment helps to categories the equipment that will require a facility shutdown. For qualitative risk analysis, a criticality risk number may be developed depending on the company operational considerations. According to API (2009), risk-based inspection, for a qualitative risk analysis the likelihood of failure may be categorized from one through five. However, it is appropriate to associate an event frequency with each likelihood category to provide guidance to determine the probability of failure as shown in Table 4-1 and consequences are represented in monetary terms (\$) as shown in Table 4-2.

Risk Matrix						
Failure Frequency						
Frequent	5	M	H	H	H	H
Probable	4	L	M	M	H	H
Occasional	3	L	M	M	M	H
Remote	2	L	L	M	M	H
Extremely Unlikely	1	L	L	L	L	M
Consequence Rating		1	2	3	4	5
Asset Damage		Negligible	Minor	Moderate	Major	Catastrophic
Production Loss (DT in Hrs.)		DT<X	DT>X<X1	DT>X1<X2	DT>X2<X3	DT>X3
Safety/Health		Near miss/ First Aid	Minor Injury	Injury with Disability	Permanent Disability	Fatalities
Environment		No effect	Minor effect	Moderate effect	Major effect	Massive effect

Figure 4-2: Qualitative Criticality risk ranking matrix

Table 4-1: Five Level of Probability of failure (Khan et al. (2014))

Possible Qualitative Rank	Annual likelihood of failure
Frequent	>0.1
Probable	0.001 to 0.01
Occasional	0.0001 to 0.001
Remote	0.00001 to 0.0001
Extremely Unlikely	<0.000001

Table 4-2: Five Level Consequence Table (Khan et al. (2014))

Possible Qualitative Rank	Economic Loss Range
Negligible	EL<\$10,000
Minor	\$10,000<EL≤\$100,000
Moderate	\$100,000<EL≤\$1,000,000
Major	\$1,000,000<EL≤\$10,000,000
Catastrophic	EL>\$10,000,000

For the case of several competing consequences for equipment/components, the highest observed risk (criticality number) among the consequences should be considered to be the most critical component. Overall risk, R, can be selected using below equation:

$$RISK = MAX(RISK_{AD}, RISK_{PL}, RISK_{OC},) \quad (4-1)$$

### 4.3.3 Module 2: Component/System failure modeling considering human error

Failure characteristics of the component or system are one of the most important parameter used to analyze and model the system failure or behavior. Since failure of a system is a probability, the rule of probability theory may be applied to compute the system failure probability from knowledge of component or system characteristics.

#### 4.3.3.1 System Failure Modeling:

A unit or system may constitute pieces of equipment arranged in series, active redundancy or in standby. Very often, these redundancies or standby is designed to take full load in case of a functional failure to avoid unplanned shutdown. Operational relationships and knowledge regarding various system elements is required to develop a system failure

model. System failures cannot be evaluated and improved until it is known that how these various elements affect system operation. A true representation of these relationships is required for prediction and assessment based on either cost or risk. A functional block diagram is developed once the critical equipment are identified to represent their relationships and provide an indication of the element which must operate successfully for the system to accomplish its intended function. Depending on the functional block diagram, system reliability or failure model equation can be developed using either standard series or series-parallel equations. Further most often inspection and maintenance modeling is considered based on a fixed time interval between two consecutive inspection and maintenance. In this paper, it is assumed that the inspection and maintenance interval will be dictated by the risk considered and will vary between two consecutive shutdown inspection and maintenance as shown in Figure 4-3. Considering the variability in shutdown interval, the reliability of the system over the life cycle can be written as follows:

$$R_{sys}(t) = \prod_{i=0}^n R(\Delta_i) \cdot R\left(t - \sum_{i=0}^n \Delta_i\right) \quad (4-2)$$

Where;

- (1)  $t > \sum_{i=0}^n \Delta_i$
- (2)  $i = 1, 2, 3 \dots \dots n$  is shutdown inspection and maintenance interval
- (3)  $\Delta_0 = 0$
- (4)  $R(0) = 1$
- (5)  $\Delta_1 > \Delta_2 > \Delta_3 > \dots \dots > \Delta_n$

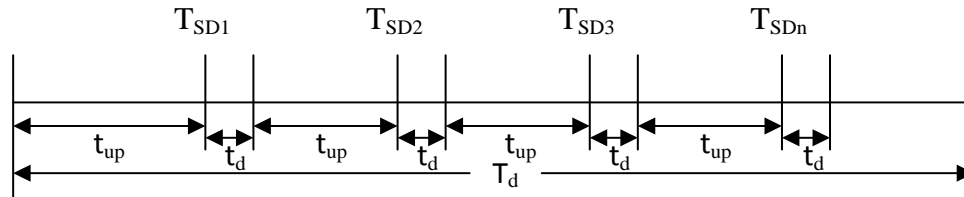

Figure 4-3: System Operational Availability

#### 4.3.3.2 Human error modeling in inspection and maintenance:

Inspection and maintenance activities are critical to improve the reliability and availability of equipment. These activities are performed not only under immense pressure to bring the facility up and running in shortest period of time but also under difficult and hazardous conditions. Even with all kind of technical advancement while designing the equipment or system, human involvement needs to be considered when performing inspection and maintenance. Human interactions with machines or systems are prone to introduce error while performing inspection and maintenance due to various factors. Human errors during inspection and maintenance activities have already produced disastrous outcomes (in millions of dollars) such as Flixborough, Three Mile Island, Piper Alpha and Bhopal accident. Sometime human errors in inspection and maintenance may lie in dormant mode for a longer period of time before leading the equipment or system to failure. An example of a loosely secure nut during maintenance may produce vibration and result into a fatigue crack over period of time. Human errors such as misinterpretation of engineering drawings and maintenance manuals, inadequate training, poor working environment, time constraint and working environment as well as processing hazards are some factors which impact human performance. Swain and Guttman (1983) have defined these factors as performance shaping factor (PSF) and listed several PSF which are linked with internal,



external, or stress related for complex man-machine interface for nuclear power plants. Wilson and McCutcheon (2003) reported that facility layout, workstation configuration, controls, hand tools, control systems, noise, vibration, lighting, temperature, force, repetition, posture, work schedule/workload, behavior based safety, labels/signs, communications, training, stress/fatigue, motivation, fitness/body size) are the areas where human factor should be considered. Toriizuka (2001) evaluated the importance of each PSF from the viewpoint of work efficiency, workload and human reliability. Any inspection and maintenance activity whether non shutdown or shutdown for a complex system consists of three major steps namely preparation activities, inspection and maintenance activities and boxing up/lining up activities before it is taken in operation. The above three steps consist of several sub-sets of task. Since these actions are performed by humans, there is always a probability of introducing an error. If the probability of inducing such human error is analyzed considering various PSF and represented by  $p$ , it can be integrated in to the system failure function of the equipment or system. Various techniques have been presented in literature to estimate the HEP. Some of the major techniques are Success Likelihood Indexing Method (SLIM), Technique for Human Error Rate Production (THERP), Justified Human Error Data Information (JHEDI) and Human Error Assessment and Reduction Technique (HEART). Kirwan (1996, 1997) and Kirwan et al. (1997) have discussed and validated these techniques in details. These techniques have been applied in Nuclear, Air and process industries. In this paper, SLIM technique is utilized to estimate human error probability and later integrated in the system failure probability. Figure 4-4 represents the SLIM process. SLIM process is based on developing the Performance Shaping Factors (PSF) and their impacts on human behavior. Generally an expert judgment is used to quantify PSF

which is used to derive a Success Likelihood Index (SLI) for each activity. A detailed set of task needs to be developed. Each task is reviewed in view of the considered PSF. Field and Technical expert judgments are used to assign a ranking and weighting to each PSF in terms of the influence on the success of a task. Eq. (4-4) is used to convert estimated SLI to estimate HEP.

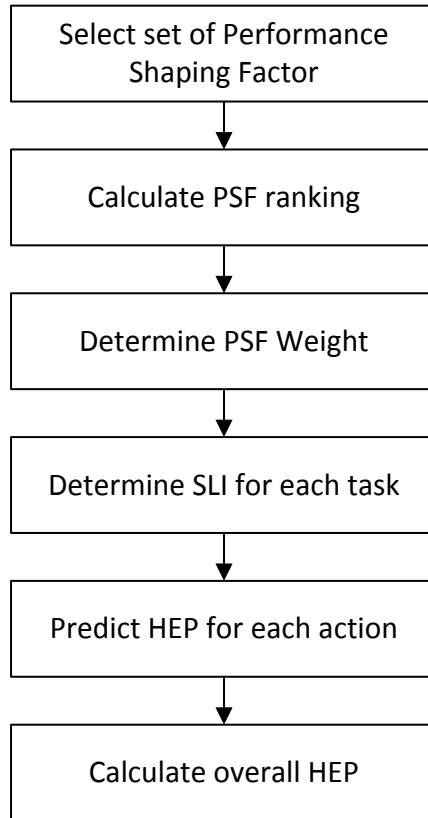

Figure 4-4: SLIM methodology to calculate HEP

$$SLI_k = \sum R_{jk} \times W_j \quad (4-3)$$

$$\text{LOG}(\text{HEP}) = a \times \text{SLI} + b \quad (4-4)$$

Where,  $\text{SLI}_k$  is the  $\text{SLI}$  for each activity  $k$ ,  $W_j$  is the importance weight for the  $j$ th  $\text{PSF}$ ,  $R_{jk}$  is the scaled rating of task  $k$  on the  $j$ th  $\text{PSF}$ . The *overall* probability of human error in inspection and maintenance can be calculated using Eq. (4-5):

$$p = \prod_{k=1}^m (1 - \text{HEP}_k) \quad (4-5)$$

Incorporating inspection and maintenance HEP in Eq. (4-6) will result in:

$$R_{\text{sys}}(t) = \prod_{i=0}^n R(\Delta_i) \cdot R\left(t - \sum_{i=0}^n \Delta_i\right) \cdot \prod_{i=1}^n (1 - p) \quad (4-6)$$

Figure 4-5 represents the impact of human induced error in the survival function of the system and is compared with no inspection and maintenance.

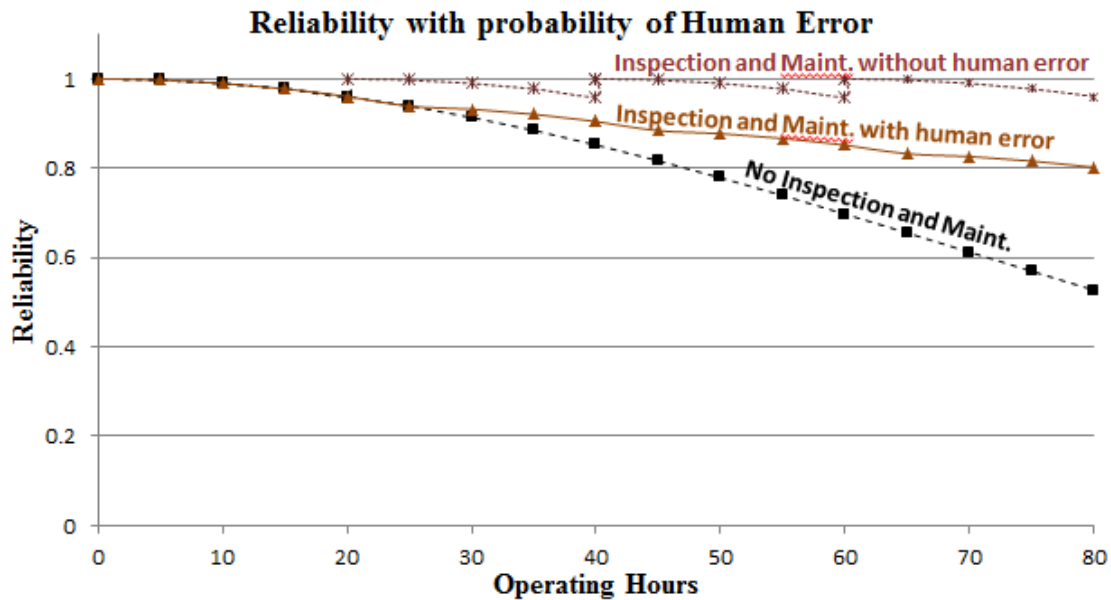

Figure 4-5: Impact of Human Error in Survival Function

#### 4.3.4 Module III – Risk-based shutdown interval estimation

Too frequent inspection and maintenance of equipment or system will increase not only the loss in revenue but also the overall operational risk exposure due to possible human error introduction in the system. On the other hand, an optimal inspection and maintenance interval will not only help to have better utilization of the inspection and maintenance resources but also reduce the risk of increased failure. It is necessary to express the probability of failure for a piece of equipment or a system as a function of time for risk-based shutdown inspection and maintenance interval estimation. In order to develop a risk-based shutdown inspection and maintenance interval, system failure probability considering human error and consequences are required to generate the overall risk exposure and are discussed below:

#### 4.3.4.1 Estimation of system failure probability

In general, operating companies keenly focus on targeting to maintain the desired reliability to achieve their operational goal. Since the system failure probability is a function of failure rate and is complementary to the reliability of the system, mathematically it can be written as:

$$F_{sys}(t) = 1 - R_{sys}(t) = \Pr \{T < t\} \quad (4-7)$$

$$F_{sys}(t) = 1 - \left[ \prod_{i=0}^n R(\Delta_i) \cdot R\left(t - \sum_{i=0}^n \Delta_i\right) \cdot \prod_{i=1}^n (1 - p) \right] \quad (4-8)$$

where  $t$  is the failure time of the system on or before a time  $T \leq t$

A system or equipment failure can be modeled using exponential, Weibull, normal or lognormal probability distribution. Plant-specific inspection and maintenance data are the best source to identify the model. However, sometime due to the limited availability of plant-specific data, test data, data bank or expert judgment is also used. Weibull distributions due to its inherent flexibility such as normal (for  $\beta = 3.4$ ) and exponential (for  $\beta = 1$ ) distributions is most commonly used to model system failure probability. In this study, the Weibull model with the parameters  $\beta$  and  $\theta$  is used to model the time dependent reliability of the equipment involved in the system. A decreasing failure rate ( $\beta < 1$ ) corresponds to an early life failure or infant mortality. A constant failure rate ( $\beta = 1$ ) suggests that items are failing from random events. An increasing failure rate ( $\beta > 1$ ) suggests that wear out is occurring and that parts are more likely to fail over time (Ghosh & Roy, 2009).

#### **4.3.4.2 Estimation of the economic consequences:**

In general, process plants such as refineries, chemical plants, natural gas processing facilities equipment operate under extreme conditions (pressure and temperature). It is due to these extreme operating conditions, failure consequences are not limited to the localized failure of component or equipment. Further these facilities process hazardous substances (hydrocarbons), failures due to leak of hydrocarbons may produce severe impact on the nearby assets, safety and health issues of the people and operational losses in the presence of an ignition source. For example in a gas processing plant, hydrocarbon release may result in flash fires, jet fires, pool fires, boiling liquid expanding vapor explosion (BLEVE), fire balls, vapor cloud explosions or toxic dispersion. In order to estimate the impact in the effected zones, operating pressure, temperature, physical and chemical properties and atmospheric conditions are required. Economic consequences due to these may be estimated based on the effects of thermal radiation and overpressure on surrounding equipment and personnel in monetary (\$) terms for effected zones. Failure to consider these consequences when developing inspection and maintenance strategies for the facility may increase the operational risk. Hameed et al. (2014) has described various equations to estimate economic consequences in monetary (\$) terms. Table 4-3 lists the summary of these equations which has been used here.

Table 4-3: Consequence Estimation (Khan et al. (2014))

<b>Economic Consequence of Asset Loss</b>		
Due to Heat Flux	$(ECAL)_x = (PDHF)_x \times AD$	(4-9)
Due to Overpressure	$ECAL = PDOP \times EZ \times AD$	(4-10)
<b>Economic Consequence of Human Health Loss (ECHHL)</b>		
Due to Heat Flux	$(ECHHL)_x = (PIHF)_x \times PD \times CF$	(4-11)
Due to Overpressure	$ECHHL = PDOP \times EZ \times PD \times CF.$	(4-12)
<b>Economic Consequence of Production Loss (ECPL)</b>		
	$ECPL = SDT \times PL \times SP$	(4-13)
<b>Economic Consequence of Inspection and Maintenance (ECSIM)</b>		
	$C_{p(i)} = C_{lp} \times t_p,$	(4-14)
	$C_{I(i)} = C_{li} \times t_i + C_{ie} \times t_i,$	(4-15)
	$C_{m(i)} = C_{lm} \times t_m + C_{sp},$	(4-16)
	$C_{ts(i)} = C_{lts} \times t_{ts},$	(4-17)
	$ECSIM_{(i)} = C_{p(i)} + C_{I(i)} + C_{m(i)} + C_{ts(i)}.$	(4-18)
The total economic consequences of shutdown ( $EC_T$ )		
	$EC_T = Max (ECAL + ECHHL)_i + \sum_{i=1}^n ECSIM + ECPL,$	(4-19)

where,  $x$  represents the various possible scenarios, PDHF is the probability of damage due to heatflux in the effected zones and AD is the asset density, PDOP is the probability of damage due to overpressure, EZ is the effected zone due to overpressure, PDHF is the probability of injury or death due to heatflux in the effected zones , PD is the population density and CF is the cost of injury or fatality, PDOP is the probability of damage due to overpressure,  $PL$  is production loss volume per day and  $SP$  is the selling price of the product per unit volume, SDT is the shutdown duration,  $C_p$  is the preparatory cost,  $C_{1p}$  is the cost of preparatory maintenance labor per hour (\$/h),  $t_p$  is the duration of the preparatory work,  $C_1$  is the inspection cost,  $C_{1I}$  is the cost of skilled inspection labor per hour (\$/h),  $C_{1e}$  is cost of inspection equipment per hour (\$/h),  $t_i$  is the duration of inspection work,  $C_m$  is the maintenance cost,  $C_{1m}$  is the cost of skilled maintenance labor per hour (\$/h),  $C_{sp}$  is the cost of spare parts consumed,  $t_m$  is the duration of maintenance work,  $C_{ts}$  is the technical support cost,  $C_{1ts}$  is the cost of a technical support specialist per hour (\$/h) and  $t$  is the duration of technical support work in hours.

#### **4.3.4.3 Risk estimation:**

Since the risk is a combination of probability and the consequence, one needs to consider all possible consequences, including safety & health, operational and non-operational consequences. In this paper, risk is estimated in terms of (\$) value due to all possible combination and can be written as:



$$\begin{aligned}
\text{RISK} = & (F_{\text{sys}}(t)) \\
& \times \left[ \text{Max} (ECAL + ECHHL)_i + \sum_{SDi=1}^n ECSIM \right. \\
& \left. + \sum_{SDi=1}^n ECPL \right] \quad (4-20)
\end{aligned}$$

#### 4.4 The application of RBSIM to a LNG processing facility

Sönmez et al. (2013) reported that energy plays a fundamental role in both manufacturing and services, and natural gas is rapidly becoming a key energy source worldwide. Since the last few decades liquefied natural gas (LNG) plants are increasing in number due to the growing demand for natural gas (NG) to meet the energy requirement. This trend is due to the fact that NG is the cleanest of the fossil fuels. LNG is a temporarily converted form of NG for storage and shipping because it occupies six hundred times less volume. The NG liquefaction process begins when the NG is extracted from the underground reservoirs and is sent to a liquefaction facility, where NG is liquefied at  $-160\text{ }^{\circ}\text{C}$ . The liquefaction plants are asset intensive which operates on continuous basis. Unavailability of major equipment or system due to any failure may have severe consequences and produce significant risk to the operating companies due to production loss, asset damage, safety and company perception. A typical onshore LNG processing plant consists of several units as shown in the following Figure 4-6. Raw gas is received from either an onshore or offshore reservoir to the inlet/receiving area where condensate and water is separated from hydrocarbon. Hydrocarbon is then pre-treated to remove corrosive and hazardous contents. These include  $\text{H}_2\text{S}$ ,  $\text{CO}_2$ , mercury, helium and water. The dry sweet gas is then cooled to

separate heavier hydrocarbon such as  $C_3$ ,  $C_4$  etc. Finally it is cooled in the cryogenic units to liquefy natural gas for storage and or shipping. In this paper, a section of gas chilling and liquefaction unit of a LNG processing facility is selected to develop shutdown inspection and maintenance interval for a targeted goal time to achieve a desired reliability (0.95). The general schematic and the block diagram of gas chilling and liquefaction unit section is shown in Figure 4-7 and is taken from Hameed and Khan (2014) previous work. The main purpose of the Gas Chilling and Liquefaction Unit is to condense the sweetened, dry, lean feed gas into LNG in the Main Cryogenic Heat Exchanger, and then sub-cool it in the Sub-cooling Heat Exchanger.

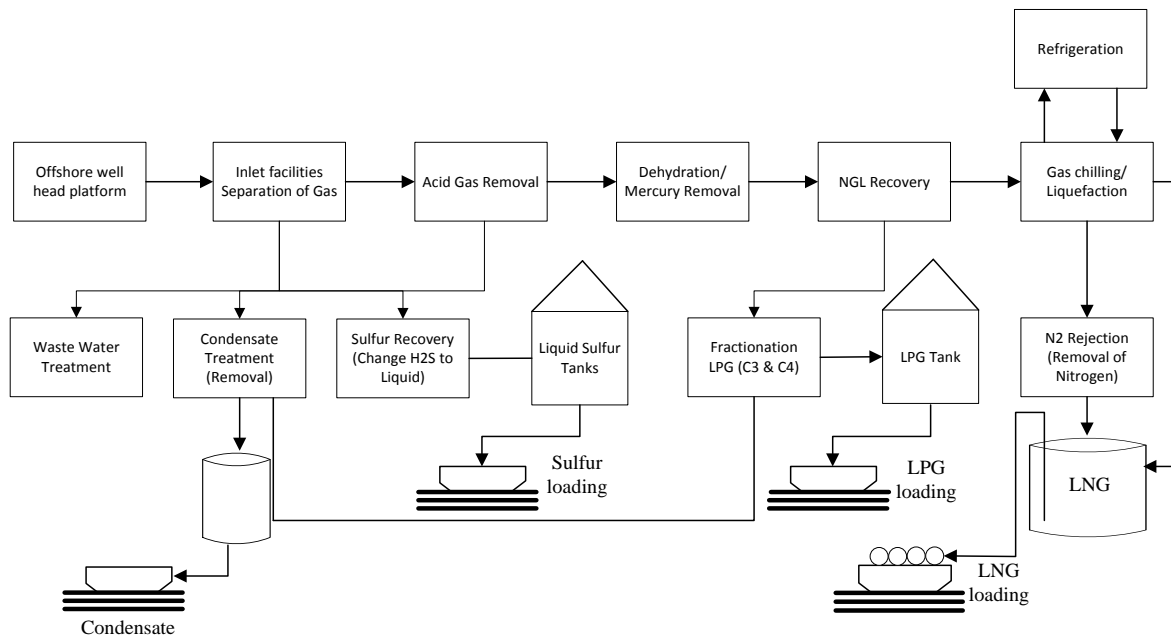

Figure 4-6: A typical LNG processing plant process flow

#### **4.4.1 Module 1: equipment selection considering criticality of operation**

Equipment criticality analysis helps to evaluate how failure of these equipment impacts the performance of asset and is used to prioritize equipment selection for inspection and maintenance. Module I of the presented methodology is applied to select critical equipment using the risk criticality matrix. The risk criticality matrix helps to estimate the risk criticality number for all equipment in the unit for all considered consequences. Using the risk criticality matrix, equipment can have a criticality number ranging from 1 to 25. Criticality number 1 indicates that the equipment has least impact while a criticality number 25 indicates significant impact on the risk. For example, if an equipment is having high probability (frequent = 5) of failure and the unavailability of the equipment having moderate impact on production, 50% loss (moderate = 3), the risk number will be 15, compared to an equipment which upon failure will result total loss of operation will get a criticality number of 25. Higher criticality number indicates that the equipment will have higher risk on operational facilities due to the unavailability, and should be considered for a shutdown inspection and maintenance. Other risk factors can also be estimated to obtain the criticality number. In the considered unit, hydraulic turbines are designed to take full load capacity, in case if one unit fails, other unit will take the load, hence it does not get a higher criticality number and is not considered for shutdown inspection and maintenance interval optimization. These can be inspected and maintained any time without taking the unit in shutdown. Equipment E01, E02, E03, E04, E05 and E06 as shown in Figure 4-7 are estimated to be having higher critical number and are selected for shutdown inspection and maintenance interval for the studied unit.

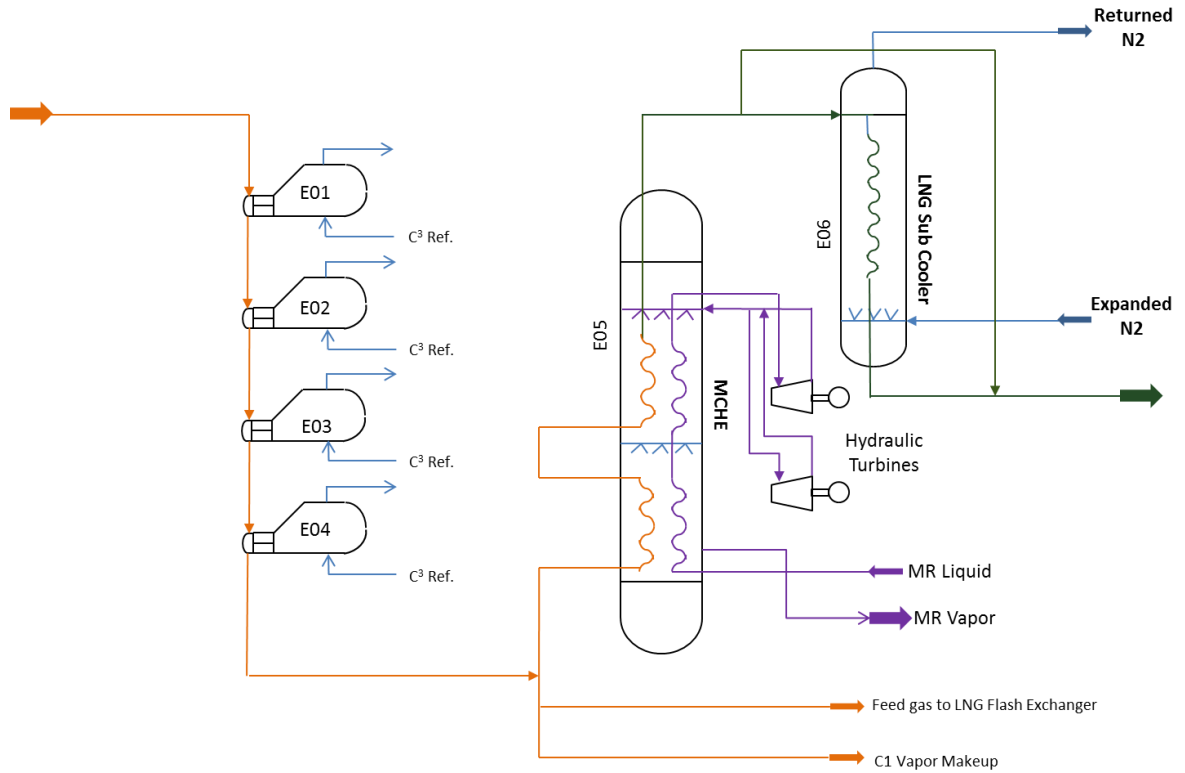

Figure 4-7: Gas Chilling and Liquefaction Unit

#### 4.4.2 Module 2: integrating human error in reliability modeling:

A functional block diagram is developed for the selected critical equipment and is shown in Figure 4-8. System failure probability is calculated using the block diagram from the selected critical equipment. Since these equipment (in this unit) operate in series, reliability equation in series is appropriate for this scenario. In order to estimate the risk-based inspection and maintenance interval, failure data is a key. For this study, failure and repair data for the selected equipment are taken from the previously published work by Hameed and Khan (2014) and is listed in Table 4-4.

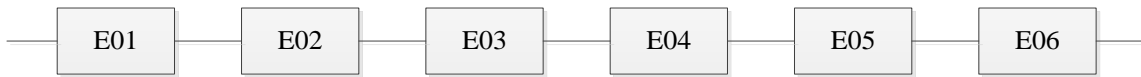

Figure 4-8: Functional block diagram of selected equipment

Table 4-4: The failure Characteristics of considered equipment.

Equipment No.	Characteristic life ( $\theta$ , h)	Shape Parameter ( $\beta$ )
E01		
E02	282,000	4.38
E03		
E04		
E05	450,000	2.0
E06		

All inspection and maintenance activities whether it is minor services, such as tightening the bolt or loose parts, cleaning and removing dust and rust, repairing and/or replacing degraded components such as bearing and seals, or performing welding to strengthen the integrity of the equipment requires human interaction. As discussed in Module II, various factors may introduced human error and result in accelerating the degradation or failure of the system. Table 4-5 list the considered PSF which may have impacts on the shutdown inspection and maintenance activities. Expert judgment from the experienced plant personnel are used to identify the significant Performance Shaping Factors and are listed in Table 4-5. These PSF are then ranked to select the top five PSF. Selected top five PSF were then assigned a weightage and is listed in Table 4-6. Table 4-7 list the general and common shutdown inspection and maintenance activities which were developed using field engineer's

experience. This information was used to estimate the HEP for individual activities using Eq. (4-3) to Eq. (4-5) as discussed in Section 4.3.3.2.

Table 4-5: List of considered PSF

<b>External PSF</b>	<b>Internal PSF</b>	<b>Stressors</b>
○ Environment	○ Training	○ Fatigue, Pain or discomfort
○ Working hours, work breaks, shift rotations	○ Experience	○ Temperature and Radiations
○ Availability and adequacy of special equipment, tools and supplies	○ Knowledge of performance standards	○ Oxygen insufficiency
○ Method, Policies and Procedure	○ Stress (Mentally or bodily)	○ Vibration
○ Criticality and Complexity of Task	○ Work Memory	○ Movement limitation
	○ Physical Condition	○ Risk and Threats

Table 4-6 : Performance Shaping Factor, Rank and Weight

Number	Performance Shaping Factor	Rank	Weight
1	Training	5	0.20
2	Experience	4	0.25
3	Time Pressure	3	0.20
4	Work Memory	2	0.15
5	Work Environment	1	0.20

Table 4-7: Common Shutdown Inspection and Maintenance activities and estimated HEP.

Task Number	Task Description	HEP
1	Receive I&M work permit	0.001594
2	Perform system blinding and isolation	1.47E-05
3	Open entry points	0.00029
4	Install ventilation System	0.00029
5	Install internal/external lighting	1.47E-05
6	Remove manways	1.47E-05
7	Install internal/external scaffolding for I&M	1.47E-05
8	Remove/Clean demisters, (if required)	0.000359
9	Clean Weld Joints, drains, nozzles etc.	0.010839
10	Carry out inspection	1.47E-05
11	Carry out repairing/maintenance works,	1.47E-05
12	Re-fix the demisters (if required)	1.47E-05
13	Remove Internal scaffoldings	1.47E-05
14	Re-fix internal manways	0.010839
15	Perform final inspection	5.07E-06
16	Final Internal Inspection	0.010839
17	Close entry points	1.47E-05
18	De-blinding & hydra tightening	1.47E-05
19	Close I&M work permit	1.47E-05

#### 4.4.3 Module III – risk-based shutdown inspection and maintenance interval:

Module III of the proposed methodology consists of estimating system failure probability, all possible consequences due to process unit shutdown and finally developing a risk profile to find the optimal shutdown inspection and maintenance intervals. Since system



failure probability is the function of time, it is modeled here using Weibull distribution. To calculate the system failure probability, the Weibull distribution parameters of the equipment are used as discussed in Module II, thus the system failure probability function can be written using Eq. (4-8). Considered gas chilling and liquefaction unit is used to process hydrocarbons and operates at higher pressure and cryogenic temperature conditions, the consequences of failure will be very high. Failure scenario considered to estimates the asset damage and human health loss for these equipment is release of hydrocarbon which upon finding an ignition source may result in explosion which could generates shock waves. Calculated shock waves are then transformed in to probability of damage due to shock wave for various effected zones. This shock wave may cause serious asset damage as well as human injury or fatality. In this particular scenario, estimated consequence is based on a radius of 200m and is listed in Table 4-8. It is important to note that the loss of life or injury suffered to the people is hard to estimate in dollars value, however the cost associated with the compensation and corporate liability needs to be taken account in consequence analysis. In this regard, published note from Judycki (1994) of the US Department of Transportation and the Federal Highway Administration published relating the injury scale (in terms of severity) to the comprehensive costs in police-reported crashes is used. In this paper production loss is estimated using Eq. (4-13) for 10 days of shutdown is considered. Plant-specific data and field engineer supports to estimate number of manhour, labor and equipment cost is considered to estimate economic consequence of each shutdown inspection and maintenance interval.

Table 4-8: Estimated failure consequences

Equipment No.	Consequences of Asset damage and human health loss in terms of (Million dollars)
E01	344.98
E02	307.29
E03	256.40
E04	88.34
E05	284.18
E06	377.76

The total calculated consequence along with Eq. (4-20) is used to generate the expected risk profile to determine the total number of shutdown intervals. Figure 4-9 show the obtained risk profile to achieve optimal shutdown inspection and maintenance interval, which would enable a level of 95.0% system reliability for a desired goal time while meeting the risk exposure to the lowest level. The shutdown inspection and maintenance interval is obtained from Figure 4-9. A sensitivity analysis is performed to study the effect of the number of shutdown days on the shutdown interval model. The results are plotted in Figure 4-10. It is evident from Figure 4-10 that operational risk profile is increasing or decreasing with the increase or decrease of shutdown duration, due to the impact of production losses, however the number of shutdown required in achieving desired system reliability over the goal time does not have significant impact. Table 4-9 shows the estimated shutdown cumulative time. It is evident from Figure 4-9 that the overall operational risk is low when a total of six shutdowns with unequal intervals are performed under the given conditions to achieve minimum operational risk (\$) per hour. The presented methodology does not only

provide optimal number of the facility shutdown interval but also suggest when these shutdowns should be planned to achieve target reliability, availability and to minimize the overall risk for the considered life of the facility.

Table 4-9: Estimated Shutdown Cumulative time

Shutdown Number	Cumulative Time
1	43222 h
2	72014 h
3	96487 h
4	117289 h
5	134971 h
6	150000 h

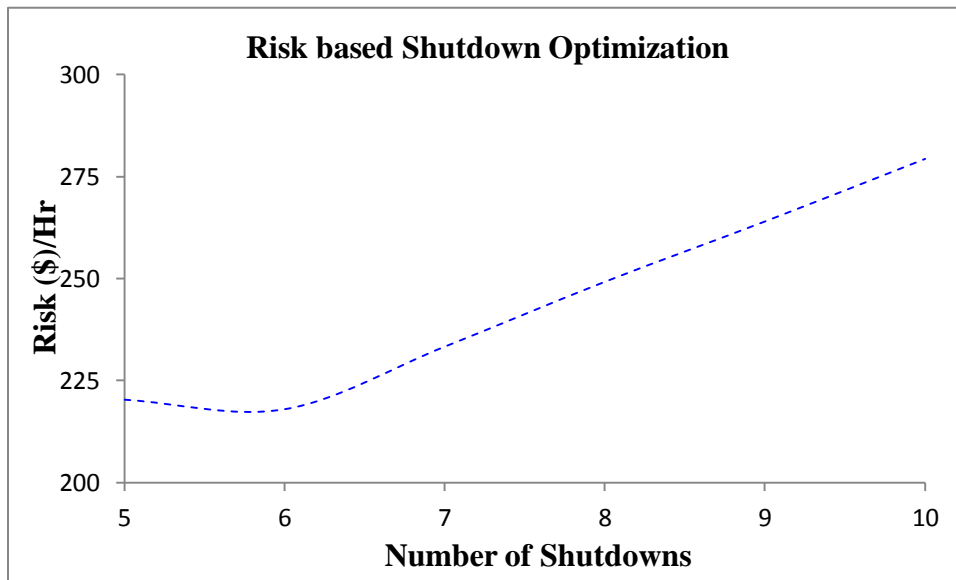

Figure 4-9: Risk-based shutdown inspection and maintenance

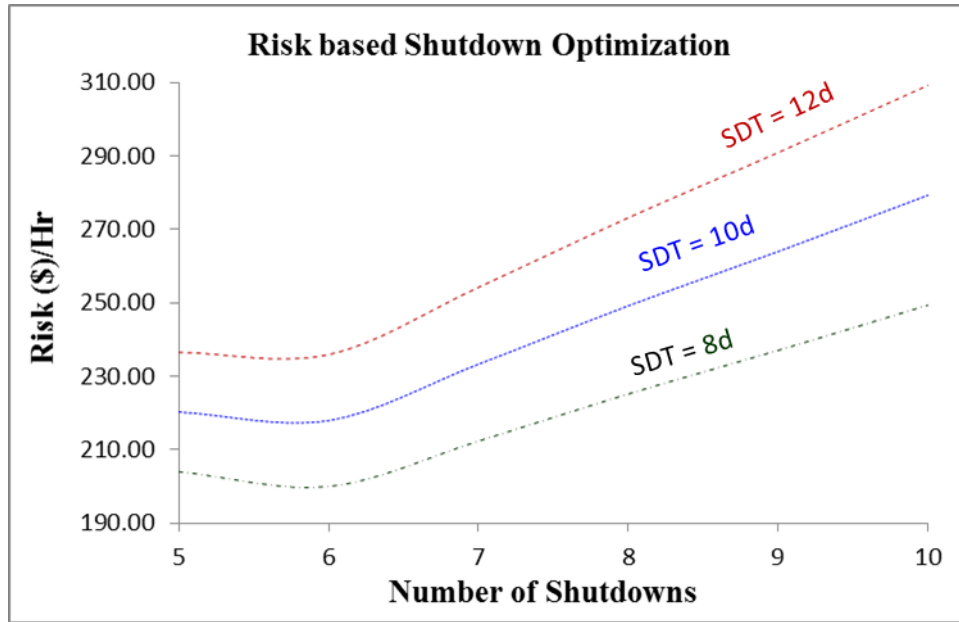

Figure 4-10: Risk-based shutdown inspection and maintenance

## 4.5 Conclusion

Shutdown inspection and maintenance activities are performed to increase the availability and reliability of facility by selecting the critical equipment to optimize the overall risk profile. Risk assessment integrates the system failure probability and consequences. A risk-based shutdown inspection and maintenance helps to select the critical equipment and systems which can't be inspected or maintained without taking the plant out of operation. This paper presents a risk-based shutdown inspection and maintenance intervals optimization for a processing facility unit considering human error which may be introduced during these activities. The unit considered in this study is a gas chilling and liquefaction unit of LNG facility. In this study, SLIs were calculated for each activity and converted into HEP using SLIM methodology. Estimated HEP is then integrated in the probability of system failure. Shutdown inspection and maintenance consequences of selected equipment were

determined and expressed in financial values (\$). The cost of inspection and maintenance were calculated using the plant data and/or using engineer's experiences. System probability of failure couples with estimated consequences is used to generate operational risk profile. By including the HEP in system failure modeling, it is safe to say that shutdown inspection and maintenance planning will help to obtain a risk profile which will not only allow achieving an optimal shutdown intervals but also the desired system reliability over the goal time by minimizing the overall risk. As the system operating life increases, the reliability decreases, which require shorter duration of inspection and maintenance to avoid excessive operational consequences. Duration of shutdown and the number of activities depends on the number of equipment selected which will go for inspection and maintenance and the scope of shutdown. The proposed methodology is an extension of Hameed and Khan (2014) and Hameed et al. (2014) to estimate shutdown interval, where in the previous studies, the impact of human error was not considered. Further these methodologies was considered to find a risk-based shutdown interval considering the equal interval whereas the proposed methodology helps to find optimal shutdown inspection and maintenance considering unequal interval over a goal time to minimize the overall operational risk. Risk-based shutdown inspection and maintenance interval methodology proposed in this paper can be applied and used for any processing or manufacturing facility. By using the risk criticality matrix, it is possible to select the critical equipment which should be considered for shutdown to optimize the overall risk.

## Chapter 5

### **Risk-based maintenance scheduling for a LNG gas sweetening unit <sup>4</sup>**

#### **Abstract**

Significant productivity increase has been observed due to advanced automation in process operations, which has also caused increased complexity in the process. The benefits from this investment can only be gained when a reliable performance with high availability and productivity is sustained. In process operations, a reliable performance requires well-planned maintenance activities. A well-planned maintenance considers planned shutdown and its financial impacts. Due to increased process complexity, it is cost effective to adopt a risk-based approach for maintenance planning. In this paper, a risk-based approach for maintenance planning and scheduling for a gas-sweetening unit in a Liquefied Natural Gas (LNG) plant is discussed. A bi-objective scheduling optimization model is developed for maintenance planning. The two conflicting objectives: i) the minimization of total

---

<sup>4</sup> *This Chapter is based on the submitted work in a peer-reviewed journal. Abdul Hameed, Syed A. Raza, Qadeer Ahmed, Faisal I. Khan and Salim Ahmed (2016), "Risk-based maintenance scheduling for a LNG gas sweetening unit," Submitted to Journal of Loss Prevention in the Process Industries. To minimize the duplication, all the references are listed in the reference list. The contribution of the authors is presented in Section titled, "Co-authorship Statement".*

expenditures incurred on maintenance related activities and ii) improving the total reliability of a gas sweetening are considered. The simulation-based optimization framework is proposed to obtain a true Pareto-front using plant specific data and MATLAB 2015b built-in Genetic Algorithm procedure. The developed framework provides a rapid decision support tool for bi-objective problem embedded with the simulation-based optimization framework.

## **5.1 Introduction**

Maintenance management is not only essential to manufacturing facilities but also highly critical to the asset intensive industries such as petrochemical, refineries and gas processing plants. These facilities consist of hundreds of equipment, which operate on a continuous basis. Some of the equipment inspection and maintenance cannot be performed until the unit or facility is taken into shutdown, which poses a significant impact to the company revenue. On the other hand, some equipment maintenance can be planned without triggering the facility shutdown, here we termed it as non-shutdown strategy. Inspection and maintenance has three critical aspects, which, what, and when? ‘Which’ relates to selecting the equipment considering the operational risk, ‘What’ relates to define maintenance task or activity and ‘When’ explains the time these activities should be performed. The right task at the right time on the right equipment is essential to make sure that facility remains in reliable operational condition. Developing maintenance management is not only about developing maintenance strategies on individual equipment basis but also to minimizing the risk to operability of the facility due to shutdown. It is vital to understand the integration and design of the systems such as acting in series, parallel, combination of series-parallel, 50% load capacity or 100% load capacity to design an optimal inspection and maintenance strategy.

Campbell, Jardine, and McGlynn (2011) reported that typically inspection and maintenance cost ranges from 28% to 52% of the total operating cost of a plant. The significant cost associated with inspection and maintenance has encouraged researchers to develop efficient methods, techniques for inspection and maintenance which have been published over the years. When developing inspection and maintenance schedule, it is critical to consider which strategy should be applied to minimize unplanned downtime, overall cost, risk exposure and to effectively utilize skilled personnel and available spares. The inspection and maintenance scheduling optimization topic has gained much attention among researchers and industrial practitioners over the last few decades. However, it is noted that there is an opportunity to introduce shutdown and non-shutdown inspection and maintenance strategy in the optimization model to minimize the overall cost and maximize reliability.

In this paper, a bi-objective risk-based maintenance scheduling optimization for a continuous processing plant considering facility shutdown is suggested. The proposed bi-objective scheduling optimization is solved using an  $\epsilon$ - constraint method and GA. If the maintenance schedule is developed without considering the facility shutdown mode, it will not only result in too frequent intervals, but also have produced huge financial losses such as production loss and maintenance cost due to higher number of shutdown. The proposed maintenance optimization methodology considers multiple conflicting objectives; several constraints with a common goal of achieving lower cost, higher reliability and efficient maintenance schedule. The prime objective of the proposed maintenance schedule optimization is to minimize the overall maintenance cost and maximize the reliability of the physical assets.



## **5.2 Literature Research**

### **5.2.1 Maintenance of Natural Gas processing plant:**

Liquefied natural gas (LNG) processing plants are not only asset intensive and complex, but also require a heavy financial investment. A careful maintenance planning for LNG assets depends on the good understanding of assets configuration and their impacts on operation. Some equipment deteriorates over time and failure of these key equipment produces an undesirable event which can lead to the shutdown of the facility. A carefully designed maintenance planning for these critical equipment may prevent unwanted breakdown. Gowid, Dixon, and Ghani (2014) developed and proposed a system redundancy and maintenance interval optimization for a Floating Liquefied Natural Gas (FLNG) export platforms to reduce the total associated maintenance cost. This was achieved by identifying the optimum maintenance intervals for the major LNG liquefaction plant components. Keshavarz, Thodi, and Khan (2011) proposed a risk-based shutdown management strategy for LNG units. A combination of preventive maintenance, active redundancy and standby redundancy was considered to achieve an optimized shutdown maintenance strategy. These proposed optimization studies cannot be applied to the existing plant, as most of the facilities do not have redundancies for liquefaction units. Nwaoha, Yang, Wang, and Bonsall (2010) used GA to model risk-based maintenance and repair cost for a liquefied natural gas containment system and its transfer arm in conjunction with probabilistic risk assessment technique to improve system safety. When developing shutdown maintenance planning for LNG or processing facilities, realizing the criticality of the equipment to the operation is very important. Hameed, Khan, and Ahmed (2014); Hameed, and Khan (2014) have proposed a risk-based shutdown interval modeling for continuous operating facilities by selecting and

analyzing the risk of critical equipment to define the facility shutdown interval. In reality, not all assets in the LNG plant required a facility shutdown to carry out maintenance. Thus, the key question is to define what would be the maintenance activities for equipment and what would be the frequency? Frequent maintenance activities on these equipment may introduce accelerated failure due to human interface and produce severe negative financial impacts due to frequent shutdown; on the other hand few of the planned maintenance activities will not help in achieving a reliable operation of the facility either. Thus, a balanced or optimized maintenance schedule is required to meet the functional requirements considering facility shutdown.

### **5.2.2 Risk-based maintenance optimization:**

Maintenance optimization is an active research topic. Single objective or multiple objectives optimization has been addressed under risk, reliability, availability, and cost. Backlund, and Hanu (2002) reported that while doing the risk analysis focus must be put on the function required of the subsystem and equipment. Garg, Monica, and Sharma (2013); Fitouhi, and Nourelfath (2014); Adhikary, Bose, Jana, Bose, D., and Mitra (2015); Salvador, and Juan-Carlos (2013); Ghosh, and Roy (2009); Rusin, and Wojaczeck (2012); Khan, and Haddara (2003, 2004a, 2004b) have presented methods to estimate the optimal maintenance and inspection interval considering cost, risk and availability. Bertolini, Bevilacqua, Ciarapica, and Giacchetta (2009) proposed a risk based inspection and maintenance strategy to minimize the overall risk considering time limit, budget and human resources. Zhaoyang, Jianfeng, Zongzhi, Jianhu, and Weifeng (2011); Wang, Cheng, Hu, and Wu (2012) proposed a risk rating criteria to select a maintenance strategy which reduces the overall risk. However,

the real-life optimization problems are quite complex and often intractable to solve using conventional optimization approaches.

### **5.2.3 Meta-heuristics approach for maintenance optimization:**

There has been significant development in the heuristics-based approaches to solve large-scale problems. Silver (2004) stated that a metaheuristic is an iterative master process that guides and modifies the operations of subordinate heuristics to produce efficiently high-quality solutions and presented an overview of various metaheuristic solution methods. Statistics presented by Jones, Mirrazavi, and Tamiz (2002) shows that 70% of the optimization problem used GA as primary meta-heuristic algorithms compared to 24% Simulated Annealing (SA) and 6% Tabu Search (TS). Dowsland (1996); and Chen, Vempati, and Aljaber (1995) reported that GA has been successfully applied to wide range of applications ranging from maintenance optimization to revenue maximization and so on. Moghaddam and Usher (2011) have explored maintenance scheduling using dynamic programming and introduction of heuristic algorithms in maintenance optimization with reliability, availability, and budget criteria. Painton, and Campbell (1995); and Coit and Smith (1996) have introduced meta-heuristics, for example GA, to effectively handle optimization problems in maintenance and reliability contexts. Hadi, Ashkan, and Isa (2012) presented a joint production, and maintenance scheduling model with multiple preventive maintenance services. A component-based heuristic algorithm was developed to solve the optimization model for a real field system while maintaining the architecture or components in a traction catenary system. Xu, Han, Wang, and Sun (2012) proposed a risk-based optimization model for system maintenance scheduling problem that consists of optimizing availability and cost of the system by balancing between system maintenance risk and failure

risk. Fu (2013) presented a selection of multiple maintenance strategy in process equipment. Three maintenance strategies namely, repair maintenance, preventive maintenance and preventive replacement on equipment reliability was analyzed. The harmony search algorithm was designed to solve the model, and the diversity of solutions was ensured by generating the new solution and the replacement process. Ahmadi, and Newby (2011) proposed an integrated model for the joint determination of both optimal inspection strategy and optimal repair policy for a manufacturing system whose resulting output is subject to system state. In this paper, an intensity control model adapted to partial information provides an optimal inspection intensity and repair degree of the system as an optimal control process to yield maximum revenue. Go, Kim, and Lee (2013) studied the problem of determining operations and maintenance schedules for a container ship equipped with various subsystems during its sailing according to a pre-determined navigation schedule. A mixed integer programming model is developed. Then, due to the complexity of the problem, a heuristic algorithm that minimizes the sum of earliness and tardiness between the due-date and the actual start time for each maintenance activity is discussed and improvement is reported over the experience based conventional method. Mirabedini, Mina, and Iranmanesh (2012) proposed a multi-objective integrated production and maintenance optimization using GA for multi parallel machines. Kancev, Gjorgiev, and Cepin (2011) proposed surveillance test interval optimization of standby equipment considering aging parameters uncertainty using GA. Esmaili (2012) developed a single machine scheduling problem with maintenance activities to optimize total cost scheduling problem using GA.

The above literature review clearly indicates that meta-heuristic such as GA has been successfully applied for maintenance scheduling optimization. However, it is found that

maintenance scheduling optimization considering facility shutdown for hydrocarbon facilities has not been explored extensively, and provides an opportunity to expand the application in this area. This paper is expected to contribute by developing a practical solution using  $\epsilon$ -constraint method, and GA to address the issue of efficient maintenance scheduling of LNG processing facility considering shutdown. In this work, inspection, maintenance and replacement are considered as various maintenance tasks to minimize the cost and maximize the system reliability.

### **5.3 LNG Gas Sweetening Unit**

At atmospheric condition when natural gas is cooled to approximately  $-162^{\circ}\text{C}$  it takes the liquid form which is generally known as liquefied natural gas (LNG). The most significant advantage of liquefying natural gas is that in liquid forms the volume of natural gas gets reduced to 1/600th the volume of in its gaseous form, which helps to transport long distance using transporting vessels. A typical LNG processing plant schematic is shown in Figure 5-1. These equipment require timely maintenance to meet safety, availability and reliability of the facility. In the gas processing facility, raw natural gas received from reservoirs is processed to remove unwanted corrosive and hazardous material before it can be liquefied and transported. In majority of the gas processing facility, a three phase raw gas is received at onshore processing plant in the inlet-receiving facility where the gas, condensate and water are separated. Condensate is usually sent to the refinery for further processing to obtain by-products. The separated natural gas from the inlet-receiving facility is processed to remove sulfur in the form of hydrogen sulfide and water in gas sweetening unit before it can be converted in the liquefied form. A general schematic of a section of gas sweetening unit is

shown in Figure 5-2 . The main function of this unit is to remove H<sub>2</sub>S, CO<sub>2</sub> and organic sulfurs from the stream and convert the gas into a sweet gas for further processing. Since this unit deals with highly corrosive and hazardous materials, equipment inspection and maintenance must be planned carefully to achieve reliable operation. Considering this, the proposed methodology has been applied to develop an optimized maintenance schedule under multiple constraints for a section of gas sweetening unit.

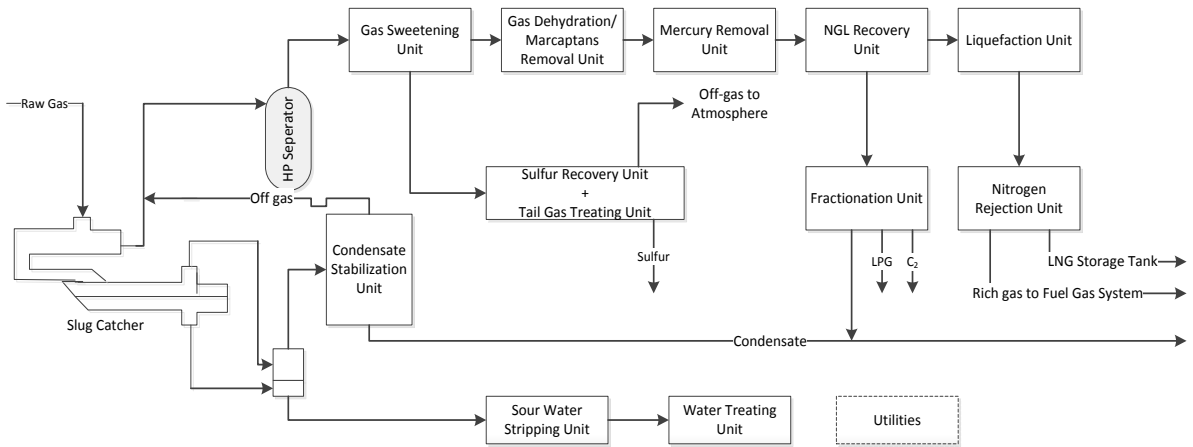

Figure 5-1: A typical LNG Process Plant (Mokhatab, Mark, Valappil, & Wood, 2014)

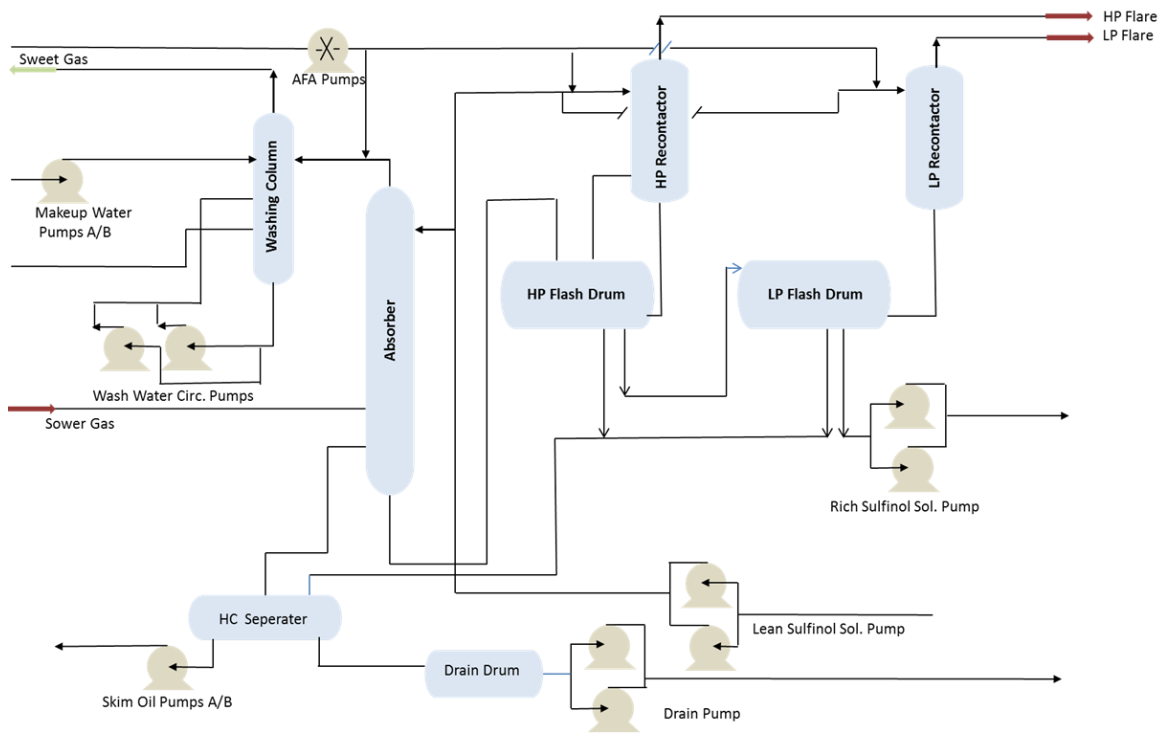

Figure 5-2: A typical Section of gas sweetening unit

Effective maintenance is one of the key functional areas in industry to address safety, reliability, plant uptime and maintenance cost. To address these objectives, maintenance optimization has gained momentum in understanding equipment failure modes, equipment age, remaining useful life and the disadvantages of only performing time-based maintenance.

Estimation of equipment age is a difficult task which drives the conservative maintenance schedules. This results in performing maintenance too early when it is not required and possibly introducing the effect of poor workmanship or human error. On the other hand, if the interval between successive maintenance is increased equipment may run into the risk of unscheduled breakdown. This situation results a demanding area of interest for the industry and researcher. The concept of inspection and maintenance management is not restricted to only the strategy but also how the strategy is being selected considering system process flow, equipment design, its maintainability, and so on. A continuous operating facility such as LNG processing plant operates in rigorous condition, 365 days a year. Developing a maintenance schedule for these equipment depends on the system configuration. These systems are designed in various possible configurations such as acting in series, parallel, 50% load sharing, 100% load sharing; thus results in two major scenarios a shutdown or non-shutdown maintenance strategy. Majority of the model presented in literature for maintenance optimization has not been specific to consider facility shutdown scenarios. This shortcoming provides an opportunity to integrate concept of shutdown in maintenance strategy to minimize cost and maximize system reliability considering aging of the equipment and error introduced in the system. Risk is usually based on the consequence and probability of an equipment breakdown or failure. Risk also relates to the operability, the operating pressures, temperatures, and age of the facilities. Maintenance planning and scheduling is important due to its direct impact on the reliability of the facility. The right maintenance activity at the right time is the goal of any maintenance organization. However, due to shortage of resources and to meet production demand sometimes a compromise is made by delaying the schedule task. Current maintenance strategies focus not only on



keeping the plant in operation but also on efficient utilization of equipment through quality and service. Processing liquefied natural gas is a hazardous process requiring considerable safety. It is a cryogenic process where the operating temperature is around  $-164\text{ }^{\circ}\text{C}$  and any failure can have catastrophic consequences. Hence, effective and optimized maintenance is a key to safety, reliability and to minimize overall maintenance cost. Maintenance strategy for hydrocarbon processing facilities is important not only because of critical application but also due to the high cost of unplanned or planned shutdowns on revenues due to production loss. These motivating factors are behind the formulation of a maintenance scheduling optimization model.

#### **5.4 Risk-based Bi-Objective Maintenance Scheduling Model**

In this section, a risk-based bi-objective mathematical model for maintenance scheduling for the gas sweetening process of a LNG plant is presented.

##### **5.4.1 Assumptions:**

Following are the assumptions to ensure the models are representative of real plant operations. These assumptions are the basis of bi-objective optimization.

- Equipment time to failure follows increasing failure with known or estimated shape and characteristics life parameter.
- Material, labor, specialist, and production cost are available.
- Labor cost/unit time is independent of equipment.
- Sufficient manpower and equipment are available to execute the job once planned.
- Inspection and maintenance times are non-negligible

## 5.4.2 Notations:

The following notations are used.

### Sets

$\Omega$  Set of Equipment, indexed such that  $\forall m = \{1,2,3, \dots, |\Omega|\}$

$T$  Set of time period intervals, indexed such that  $\forall t = \{1,2,3, \dots, |T|\}$

### Decision Variables

$X_{mt}$   $\begin{cases} 1 & \text{Maintenance (M) task is performed for an equipment } m \text{ at period } t \\ 0 & \text{Otherwise} \end{cases}$

$Y_{mt}$   $\begin{cases} 1 & \text{Replacement (R) task is performed for an equipment } m \text{ at period } t \\ 0 & \text{Otherwise} \end{cases}$

$Z_{mt}$   $\begin{cases} 1 & \text{Inspection (I) task is performed for an equipment } m \text{ at period } t \\ 0 & \text{Otherwise} \end{cases}$

### Parameters

$L$  Length of the planning horizon

$CF_m$  Cost of corrective (failure) task of equipment  $m$

$CLF_m$  labor cost/hour to perform a corrective task of equipment  $m$

$CR_m$  Cost of replacement of components in equipment  $m$

$CLR_m$  labor cost/hour to perform a replacement task of equipment  $m$

$CM_m$  Cost of maintenance of equipment  $m$

$CLM_m$  labor cost/hour to perform a maintenance task of equipment  $m$

$CMT_m$  cost of material of an equipment  $m$

$CI_m$  Cost of inspection of equipment  $m$

$CLI_m$	labor cost/hour to perform an inspection task of equipment $m$
$ETC$	Expected total inspection and maintenance cost
$HP$	High pressure
$LP$	Low pressure
$R_{sys}$	Overall system reliability
$TF_m$	Corrective repair time at equipment $m$
$TM_m$	time required to perform a maintenance at equipment $m$
$TR_m$	time required to perform a replacement at equipment $m$
$TI_m$	time required to perform an inspection at equipment $m$
$\beta_m$	Shape parameter of equipment $m$
$\lambda_m$	Scale parameter of equipment $m$
$\alpha_m$	Improvement factor of equipment $m$
$\nu_m$	Rate of occurrence of failure (ROCOF)
$\rho_m$	failure cost factor of equipment $m$
$E[N_{mt}]$	Expected number of failures of equipment $m$ at time $t$
$r_{mt}$	Reliability of an equipment $m$ at time $t$
$AS_{mt}$	Age of equipment $m$ at start of period $t$
$AE_{mt}$	Age of equipment $m$ at end of period $t$

### 5.4.3 Preliminaries:

In a typical LNG production facility, many maintenance actions are taken to ensure the functionality of each equipment by properly capturing its failure modes and assigning suitable tasks such as inspection, preventive maintenance or replacement. One of the objectives of this work is to develop maintenance task such as inspection, preventive maintenance and repair schedule for each equipment ( $m$ ), for a planning horizon ( $L$ ). While

developing this optimized maintenance schedule, the overall planning horizon is broken in equally spaced period i.e.  $L/|T|$ . At the end of each period, the system is analyzed to select which maintenance activity should be performed such as inspection (I), preventive maintenance (M) or replacement (R). Here the inspection task is considered to be an operator based inspection. These inspections (I) activities are specific to the operators using their sensory element such as visuals, hear, touch and feel to analyze the equipment behavior and report to the maintenance team if any un-wanted condition is observed such as noise, leak etc. etc. Based on the operator based inspection, if required, maintenance team performs the detail investigation and takes any necessary action. The operator based inspection does not change the failure rate of the equipment. At the same time, operator based inspection ease the maintenance resource utilization and helps in reducing the maintenance cost. In contrast, a predefined planned maintenance such as oil change or grease filling help to improve the degradation in the equipment failure characteristic. In industry these actions are called as preventive maintenance or simply maintenance (M). These actions help to improve the condition of the equipment. However, there is always a chance of introducing human error. Further, a corrective maintenance action is taken if a sudden failure of a component is observed while the system is in operational state. Corrective task or replacement task is synonymously being used in the industry. Corrective task is initiated when a sudden failure of equipment is observed. On the other hand, a replacement activity (R) may be of a planned replacement of seal, bearing and other components which may be in the wear-out zone of the failure characteristic. These actions will improve the equipment condition. Ahmed et al. (2015) has discussed these activities in greater details.

Many state-of-the-art computerized maintenance management systems have been developed to manage, execute, record and track these activities. These systems also help to obtain real operational failure data to perform equipment and system studies and failure investigations.

## **5.5 Operational Risk-based Equipment Selection:**

A risk-based approach for equipment selection to a section of gas sweetening unit of a LNG plant is outlined in this section. As described earlier in Section 5.3 (Figure 5-2) that a typical gas sweetening unit in an LNG plant consists of a large number of equipment and it would be very difficult to plan and manage the maintenance activities at once. Indeed, some equipment are likely to be at more risk of failure such as rotating equipment compared to stationary equipment. Also in certain cases, a planned maintenance action on some of the equipment cannot be performed, and requires the unit or plant to be taken out of operation. This situation is generally known as shutdown. On the other hand, some units or equipment do not impact the overall facility operation and hence, maintenance activity can be performed during normal operation. Identifying and integrating such systems and equipment is one of the most important aspects to achieve a risk-based optimal maintenance schedule without impacting operability and loss of revenue due to un-necessary shutdowns. A sound approach will be to plan and schedule maintenance activity considering the operational risk of the facility.

Generally risk is defined as the resultant of the probability of an undesired event and its consequences. Assessing and performing a risk assessment require a cross-functional team with detailed knowledge about the system and function being analyzed. Risk can be

measured in using the probability of failure and its relation to multi facet consequences such as operation loss due to facility shutdown, inspection and maintenance cost due to incorrect planning, environment and safety impacts on the facility and people. API (2009) guideline suggests that a risk matrix is an effective tool to show the distribution of risk associated with a plant or a process. The size of a risk matrix may vary, such as 5 ×5, 4×4 and so on. In this study, a 3×3 risk assessment matrix is used to segregate and categorize equipment for inspection and maintenance considering a unit or facility shutdown. A 3×3 risk matrix for probability of loss of operation and consequence (\$) is shown in Figure 5-3. To exemplify, if the consequence is as high as 3 and the probability of the failure is high as 3, the risk exposure will be maximum i.e. 9. In order to apply the risk matrix, facility needs to be broken down into small manageable units. All equipment in the gas sweetening unit of LNG plant are reviewed using the risk matrix to identify a quantitative measure of risk (also known as risk index) representing the impact on facility operability. Equipment having impact on facility operation with a higher risk index should be given higher priority in planning for shutdown inspection and maintenance strategy while others with a lower risk may be considered lower in the priority. This assessment process is performed for all equipment until the complete unit is analyzed as shown in Figure 5-2. One significant advantage of using the risk segregation would be to allocate and use skilled resources for the systems which are critical for plant operability and availability. Further, the proposed risk assessment will help to establish the equipment or system which will require facility shutdown for inspection and maintenance and help to make better planning. However, it should be noted that the risk criteria can vary from organization to organization, depending on their exposure and tolerance to absorb the consequences of the facility shutdown.

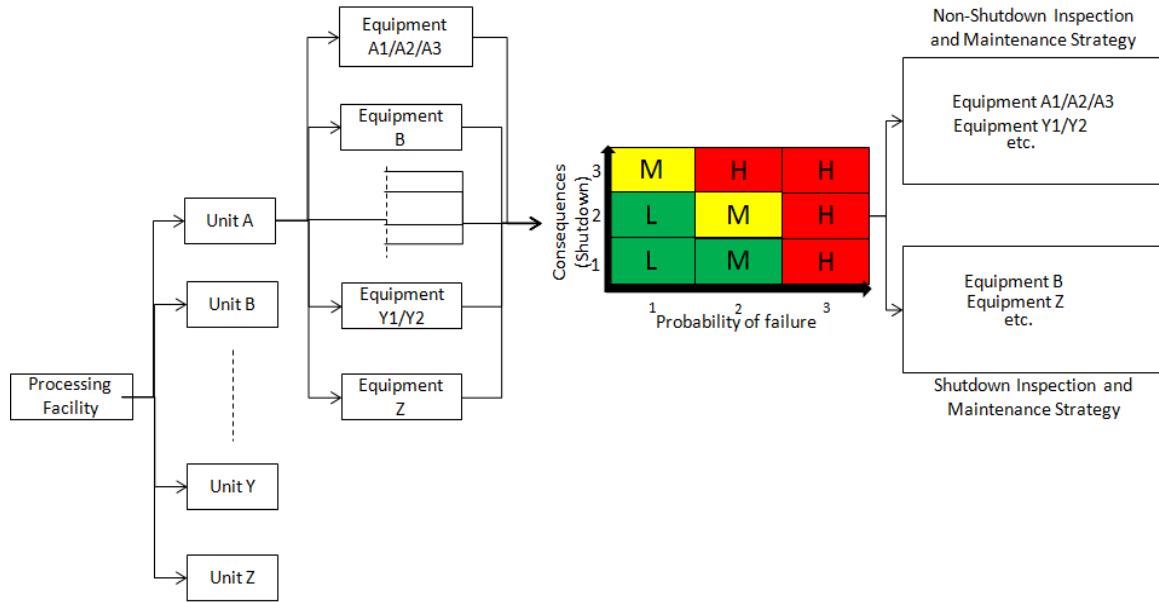

Figure 5-3: Operational Risk-based Equipment Selection

### 5.5.1 Modeling equipment failure mode:

While modeling the equipment failure mode, equipment is classified as repairable or non-repairable. Repairable equipment may include compressors, turbines, pumps, motors, valves etc. In contrast to this, non-repairable systems are more often the electronic modules. Generally corrective maintenance activities are taken when a repairable system fails. However, this strategy creates significant economic consequence in contrast to a planned maintenance which could be of inspection, preventive maintenance or replacement nature. Knowing and understanding the failure mode and their modeling is vital in developing the planned maintenance schedules for a reliable plant operation. Failure data obtained from actual operation provides better insight when developing the model as operational failures occurs under the actual operation and environments and provides an accurate representation of system behavior. Kapur and Lamberson (1977) reported that Weibull distribution is

considered as generalized failure model and is often used in reliability analysis due to its inherent flexibility to model increasing or decreasing failure rates. In reality equipment failure pattern does not always tend to be independent of each other; in this case a Non-Homogeneous Poisson Process (NHPP) can be used to model the time-dependent random failures. Ahmed, Moghaddam, Raza, and Khan (2015); Moghaddam and Usher (2011) and many other researchers have used this approach. In this article we assume that the selected equipment are repairable. It is also assumed that failure, repair, replacement and inspection task can be scheduled and time to failure follows a NHPP. Each equipment in the system is assumed to have an increasing failure rate. For non-homogeneous Poisson process, failure rate is a function of time. As we are considering increasing failure rate, Rate of Occurrence of Failure (ROCOF),  $v_m(t)$  is given by Eq. (1);

$$v_m(t) = \lambda_m \cdot \beta_m \cdot t^{(\beta_m-1)}, \quad \forall m = 1, \dots, |\Omega| \quad (5-1)$$

In Eq. (5-1)  $\lambda_m$ ,  $\beta_m$ ,  $t$  are scale parameter, shape parameter, and  $t$  is the time interval. Using Eq. (5-1), expected number of failures can be computed as follows:

$$E[N_{mt}] = \int_{AS_{mt}}^{AE_{mt}} v_m(t) dt, = \lambda_m (AE_{mt})^{\beta_m} - \lambda_m (AS_{mt})^{\beta_m}, \quad (5-2)$$

$$\forall m = 1, \dots, |\Omega| ; t = 1, \dots, |T|$$

### 5.5.2 Equipment age estimation:

Age of an equipment,  $m$  at a given time,  $t$  with respect to the different tasks such as inspection (I), Maintenance (M), and Replacement (R) is estimated by Ahmed et al. (2015) and is represented in Eq. (5-3) to Eq. (5-7). Further, the maintenance task is considered to be



imperfect, and therefore after the maintenance task the equipment does not return to as good as new ( $AE=0$ ) and its age is reduced by a factor  $\alpha_m$  for an equipment, m.

Inspection Task

$$AS_{mt+1} = AE_{mt}, \quad \forall m = 1, \dots, |\Omega| ; t = 1, \dots |T| \quad (5-3)$$

Maintenance Task:

$$AS_{mt+1} = \alpha_m \cdot AE_{mt}, \quad \forall m = 1, \dots, |\Omega| ; t = 1, \dots |T| \quad (5-4)$$

Replacement Task:

$$AE_{mt} = 1, \quad \forall m = 1, \dots, |\Omega| ; t = 1, \dots |T| \quad (5-5)$$

$$AS_{mt+1} = 0, \quad \forall m = 1, \dots, |\Omega| ; t = 1, \dots |T| \quad (5-6)$$

Considering the above maintenance task, if the age of the system at the end of each period t for equipment m can be obtained from Eq. (7)

$$AE_{mt} = AS_{mt} + \frac{L}{T}, \quad \forall m = 1, \dots, |\Omega| ; t = 1, \dots |T| \quad (5-7)$$

### 5.5.3 Maintenance activities costing:

Performing a maintenance activity such as inspection, corrective or preventive maintenance and replacement for any equipment requires skilled resources and materials. Consuming these resources derives various cost activities and is an increasing function depending upon the nature and number of time action is taken over the life span of the facility. The economic consequence (cost) of these activities has been discussed in detail by Ahmed et al. (2015) and is summarized in Eq. (5-8) to Eq. (5-11).

Inspection Task:

$$CI_m = (TI_m \times CLI_m), \quad \forall m = 1, \dots, |\Omega| ; t = 1, \dots, |T| \quad (5-8)$$

Where in Eq. (8),  $TI_m$  is the time for inspecting equipment  $m$  and  $CLI_m$  is the cost of labor for inspection.

Maintenance Task:

$$CM_m = (TM_m \times CLM_m), \quad \forall m = 1, \dots, |\Omega| ; t = 1, \dots, |T| \quad (5-9)$$

Where in Eq. (9),  $TM_m$  is the time required to carry out maintenance of equipment  $m$  and  $CLM_m$  is the cost of maintenance labor.

Replacement Task:

$$CR_m = (TR_m \times CLR_m + CMT_m), \quad \forall m = 1, \dots, |\Omega| \quad (5-10)$$

Where in Eq. (5-10),  $TR_m$  is the time required to replace an equipment  $m$ ,  $CLR_m$  is the cost of replacement labor and  $CMT_m$  is the replacement material cost. Due to various failure natures, the material cost is not considered here.

In the case of a failure, an unplanned replacement is carried out. It is assumed that this cost of replacement due to failure would be;

$$CF_m = \rho_m \times (TF_m \times CLF_m + CMT_m), \quad \forall m = 1, \dots, |\Omega| \quad (5-11)$$

Where in Eq. (5-11),  $TF_m$  is the time required to replace a failed equipment  $m$ ,  $CLF_m$  is the cost of labor to replace a failed equipment,  $\rho_m$  is the failure cost factor of equipment  $m$ , and  $CMT_m$  is the replaced material cost.

In addition to the above, one of the major and significant cost contributor is the production loss due to the facility shutdown. Since, in this proposed methodology, the maintenance schedule is designed such that there is no impact on operational availability; the cost of production loss is not considered.

#### 5.5.4 System reliability estimation:

We assume that the failure rate function of an equipment follows an increasing failure pattern and the rate of failure of occurrence for repairable system follows a NHPP, the reliability,  $r_{mt}$  of an equipment  $m$  for a given period  $t$  is computed using Eq. (5-12),

$$r_{mt} = e^{-E[N_{mt}]} = e^{-(\lambda_m (AE_{mt})^{\beta_m} - \lambda_m (AS_{mt})^{\beta_m})}, \quad (5-12)$$

$$\forall m = 1, \dots, |\Omega|; t = 1, \dots, |T|$$

However, when various subsystems are interlinked to each other, the system functionality depends on the function of each of the subsystem considered. Considering that the failures of each subsystem are independent, the system reliability is the product of the reliability of each individual subsystem for a considered interval. Thus for a system acting in series, reliability equation can be written as,

$$R_{sys} = \prod_{m=1}^{|\Omega|} \prod_{t=1}^{|T|} e^{-(\lambda_m (AE_{mt})^{\beta_m} - \lambda_m (AS_{mt})^{\beta_m})} \quad (5-13)$$

#### 5.6 Bi-objective model formulation

Damghani, Abtahi, and Tavana (2013) reported that epsilon-constraint method is one of the methodologies to solve multi-objective optimization. In this method decision makers select one objective function out of  $n$  to be optimized, while the remaining objective functions are put as a constraints to be less than or equal to given target values. We use an epsilon-constraint framework, and this has been used in other areas of research as well. Berube, Gendreau, and Potvin (2009) provided evidences that Pareto set of bi-objective

problem can be generated more efficiently using the epsilon-constraint method. Laumanns, Thiele, and Zitzler (2006); Amirian and Sahraeian (2015); and Morabi, Owlia, Bashiri, and Doroudyan (2015) have used this method for multi-objective decision problem.

In this paper expected total estimated cost ( $ETC$ ) and system reliability ( $R_{sys}$ ) are considered as the two objectives to optimize and the decision is the complete schedule for inspection (I), Maintenance (M), and Replacement (R)

*BONIP: Min ETC*

$$= \sum_{m=1}^{|\Omega|} \sum_{t=1}^{|\mathbb{T}|} [CF_m \cdot [N_{mt}] + \{(CM_m \cdot X_{mt}) + (CR_m \cdot Y_{mt}) + (CI_m \cdot Z_{mt})\}] \quad (5-14)$$

$$Max R_{sys} = \prod_{m=1}^{|\Omega|} \prod_{t=1}^{|\mathbb{T}|} e^{-(\lambda_m (AE_{mt})^{\beta_m} - \lambda_m (AS_{mt})^{\beta_m})} \quad (5-15)$$

5. *Subject to:*

6.

$$AS_{m1} = 0, \quad \forall m = 1, \dots, |\Omega| \quad (5-16)$$

$$AS_{mt} = (AE_{mt-1})Z_{mt} + (\alpha_m \cdot AE_{mt-1}) \cdot X_{mt}, \quad (5-17)$$

$$\forall m = 1, \dots, |\Omega|; t = 2, \dots, |\mathbb{T}|$$

$$AE_{mt} = AS_{mt} + \frac{L}{T}, \quad \forall m = 1, \dots, |\Omega|; t = 1, \dots, |\mathbb{T}| \quad (5-18)$$

$$X_{mt} + Y_{mt} + Z_{mt} = 1 \quad (5-19)$$

$$AS_{mt}, AE_{mt} \geq 0 \quad (5-20)$$

$$X_{mt}, Y_{mt}, Z_{mt} = \{0, 1\} \quad (5-21)$$

Eq. (5-16) to Eq. (5-21) represents various constraints used in designing the model. Where, Eq. (5-16) sets the initial age to zero for each subsystem at the beginning of the

planning horizon, Eq. (5-17) and Eq. (5-18) are used to estimate the effective age of the equipment due to various activities performed over the period, Eq. (5-19) prevents simultaneous activities scheduling for an equipment, Eq. (5-20) makes sure that in all cases the equipment age at the beginning or end of the period is always positive and more than zero and finally Eq. (5-21) defines various maintenance activities as a binary variables and restricts the values to be positive numbers.

### 5.6.1 Proposed solution approach

In Figure 5-4, a solution framework is presented. It is mainly a simulation-based optimization approach. The risk-based equipment selection has been completed in section 5.5 and a bi-objective nonlinear integer program (BONIP) is proposed in section 5.6. Next, following the solution suggested in Figure 5-4, we developed an  $\epsilon$ -constraint method to transform BONIP into a single objective function which can be solved more conveniently.

*SONIP: Min ETC*

$$= \sum_{m=1}^{|\Omega|} \sum_{t=1}^{|T|} [CF_m \cdot [N_{mt}] + \{(CM_m \cdot X_{mt}) + (CR_m \cdot Y_{mt}) + (CI_m \cdot Z_{mt})\}] \quad (5-22)$$

*Subject to:*

$$R_{sys} \geq R_{target} \quad (5-23)$$

And constraints defined in Eq. (16) to Eq. (21).

In Single Objective Nonlinear Integer Program (SONIP), the reliability objective  $R_{sys}$  is transformed as a constraint.

### **5.6.2 Decision variables re-orientation:**

In Figure 5-5, we have explored the structure of the decision variables ( $X_{mt}$ ,  $Y_{mt}$ ,  $Z_{mt}$ ) and have shown how we can generate a schedule ( $\mathcal{S}$ ). We can observe here that using the schedule,  $\mathcal{S}$ , it reduces the decision variables from  $3 \times |\Omega| \times |T|$  to considerably less,  $|\Omega| \times |T|$  variables in the schedule,  $\mathcal{S}$ . Each cell in the Schedule matrix can take either of three actions: Inspection ( $I$ ), Maintenance ( $M$ ), or Replacement ( $R$ ).

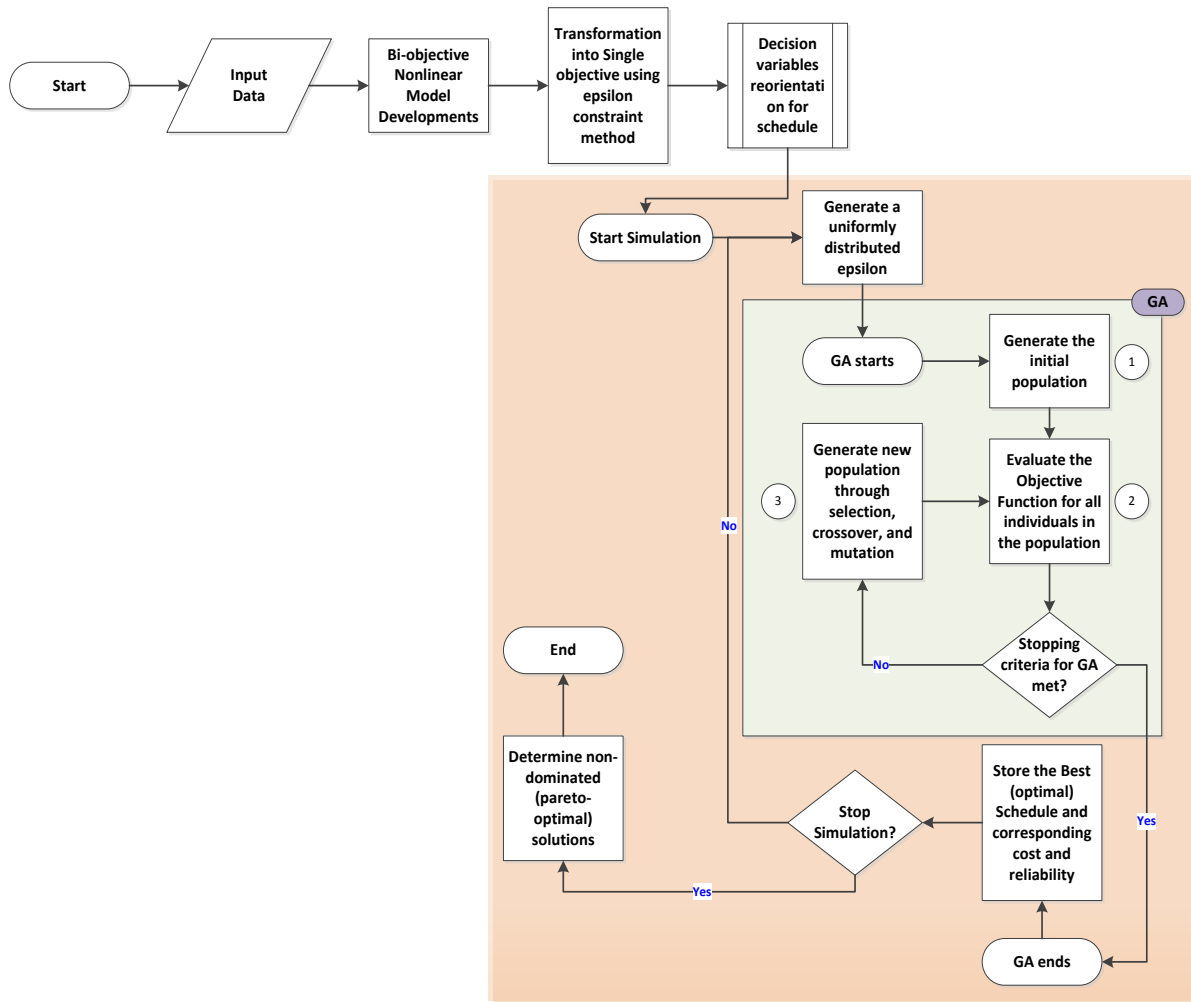

Figure 5-4: Proposed solution framework

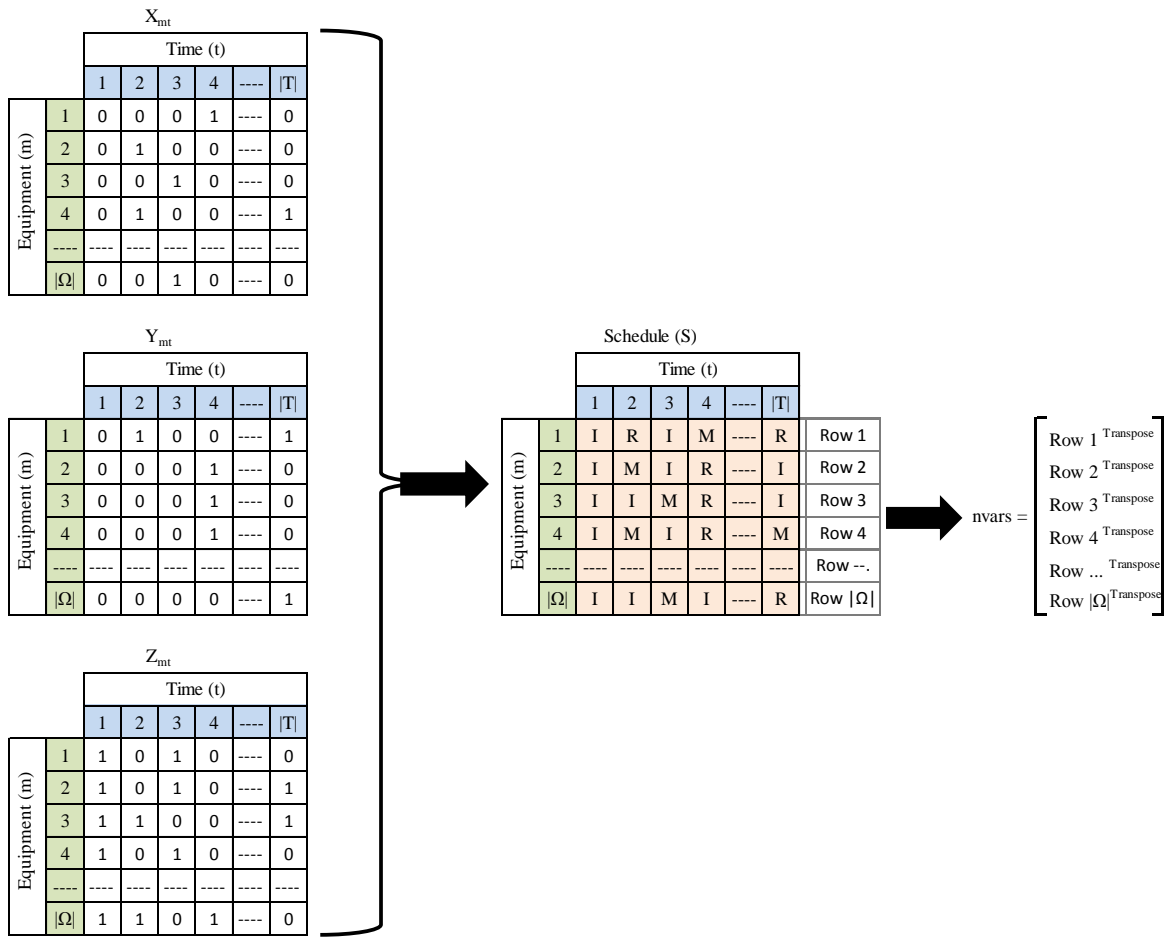

Figure 5-5: Decision Variable re-orientation

Using re-orientation presented in Figure 5-5, we can reduce the total number of decision variable to exact one-third of the original problem *SONIP*. Thus, we get a reduced problem *SONIP'*. We observe that in *SONIP'* the decision variable is  $\mathcal{S}$



$$SONIP' : \min_{\mathbf{S}} ETC$$

$$= \sum_{m=1}^{|\Omega|} \sum_{t=1}^{|T|} [CF_m \cdot [N_{mt}] + \{(CM_m \cdot X_{mt}) + (CR_m \cdot Y_{mt}) + (CI_m \cdot Z_{mt})\}] \quad (5-24)$$

Subject to:

$$R_{sys} \geq R_{target} \quad (5-25)$$

The matrix  $\mathbf{S}$  contains elements as outlined in Figure 5-5. Using Eq. (24), we can compute ETC by recoding  $S_{mt} = \{I, M, R\}$  into  $X_{mt}$ ,  $Y_{mt}$ , and  $Z_{mt}$ . Given  $S_{mt} = I$ , then  $X_{mt} = 1$ ,  $Y_{mt} = 0$ ,  $Z_{mt} = 0$ . Similarly for other values of  $S_{mt}$ , the  $X_{mt}$ ,  $Y_{mt}$ , and  $Z_{mt}$  are easily translated. Notice that constraints in Eq.(16)-(21) are removed as the proposed solution using schedule,  $\mathbf{S}$  resolves the selection decision among the three operation  $\{I, M, R\}$ , that was earlier addressed using, into  $X_{mt}$ ,  $Y_{mt}$ , and  $Z_{mt}$ . Similarly, for a given schedule,  $\mathbf{S}$ , the reliability,  $R_{sys}$  can be estimated using Eq. (15)

### 5.6.3 Genetic Algorithm (GA) implementation:

GA is a meta-heuristic, which belongs to the class of evolutionary algorithms (Deb, 2001). It mimics the process of natural evolution like inheritance, mutation, selection, and crossover in pursuit to find the best solution to an optimization problem (Kaveshgar, Huynh, & Rahimian, 2012). In the proposed solution framework as shown in Figure 5-4, we have utilized the GA provided in Global Optimization tool in MATLAB (2015b). The current version of the toolbox has incorporated increased functionality and enables the built-in GA

procedure to handle the nonlinear mixed integer optimization problem (NLMIP) such as the one presented in *SONIP'*. In the following we discuss the important features.

The procedure starts with the knowledge of the input data from the LNG plant gas sweetening process unit. The data includes information regarding equipment failure, and the estimated cost for each equipment regarding the inspection, preventive maintenance, planned replacement, and replacement or repair. The planning horizon is also decided at this stage. There are four main procedures a typical GA implementation performs:

### 5.6.3.1 Initial population generation:

Typically GA procedure starts with the creation of a randomly generated initial population. Using the decision variable re-orientation framework presented in Figure 5-6 an individual solution, 'schedule',  $\mathbf{S}$  which is also referred to as chromosome is randomly generated. The population size valuation could be arbitrarily set in the population generation option in 'gaoptimset' in the MATLAB (2015b) 'ga' procedure. In Figure 5-4, the procedure is represented in Step 1 in the GA related operators which is repeated for each simulation. In this implementation we have generated initial population using 'PopulationSize' parameters in 'gaoptimset'. In the following, the main procedure of MATLAB (2015b) 'ga' along with the options used is presented.

```
'options =gaoptimset('PopulationSize', 'Generations', 'EliteCount', 'TolFun', 'PlotFcns',  
@gaplotbestf)'
```

The MATLAB 2015b built-in procedure used is:

```
[x,fval,exitflag] = ga(@cost_obj,nvars,[],[],[],[],lb,ub,nonlcon1,IntCon,options),
```

Table 5-1 and Table 5-2 outline the user-defined and built-in parameters selection. In addition to the stated parameters in Table 5-1 and Table 5-2, all other parameters in 'ga'

procedure are set to their default values. A detailed documentation on how ‘ga’ built-in procedure works is available at MATLAB (2015b)<sup>a</sup> Global Optimization Toolbox. However, the problem that we have addressed here is an integer program which requires several modifications to basic ‘ga’ procedure. In this implementation for ‘ga’ procedure for our problem, we have restricted to default settings for crossover, mutation, special creation in order to keep the decision variables integers. These details on default settings can be found at MATLAB (2015b)<sup>b</sup> Global Optimization Toolbox.

Deep et al. (2009) have discussed the use of GA for constrained integer programming problems. ‘ga’ procedure used penalty functions as suggested in Deep et al. (2009) and Deb (2000) for handling nonlinear constraint in *SONIP*'. The MATLAB (2015b) built-in function ‘ga’ also suits this implementation of the integer variable problems as there are no equality constraints in *SONIP*'. Due to integer variables, no custom creation functions such as (‘CreationFcn’ option), crossover function (‘CrossoverFcn’ option), mutation function (‘MutationFcn’ option), or initial scores (‘InitialScores’ option) can be user-supplied in ‘ga’. These functions are self-selected in MATLAB default setting in ‘ga’ procedure. In the simulation, to maintain the integer decision variables, ‘ga’ have used special creation. Crossover, and mutation functions, and their detailed documentation is also available at MATLAB (2015b)<sup>c</sup> Global Optimization Toolbox.

Table 5-1: MATLAB (2015b) built-in procedure ‘ga’ related selected parameters in  
‘gaoptimset’

Parameters	Remarks	Selection value(s)
‘PopulationSize’	The number of individual chromosomes (solutions) in a generation	150
‘Generations’	Total number of generations explored in simulation run	500
‘EliteCount’	Number of individual in the current generation guaranteed to survive for next generation.	10 (MATLAB 2015b, default)
‘TolFun’	Function tolerance, i.e., the different between the objective values improved	1e-08
‘PlotFcns’	Optional. It is used to graph the best total expected cost	Built-in parameters
‘SelectionFcn’	Selection options specify how the genetic algorithm chooses parents for the next generation.	Binary tournament, default for integer problem

Table 5-2: MATLAB (2015b) built-in procedure ‘ga’ user-defined functions and parameters

Parameters	Remarks	Selection value(s)
@cost_obj	User-defined function to compute the total expected cost	Not applicable
nvars	Total number of decision variables. A column vector of size 168 containing values, ‘1’, ‘2’, ‘3’	$ T  \times  \Omega  = 168$ , where $M = 7$ , and $T = 24$ , Indicators 1= Inspection, 2= Maintenance, 3= Replacement
lb	Lower bound column vector of size 168 all values are ones, i.e., lb=ones(168,1)	1= Inspection
ub	Lower bound column vector of size 168 all values are set at three, i.e., ub=3 * ones(168,1)	3= Replacement
Nonlcon	User-defined non-linear constraint for reliability	
IntCon	The total number of integer values.	Set to 168, since $ T  \times  \Omega  = 168$ . All variables are integers.

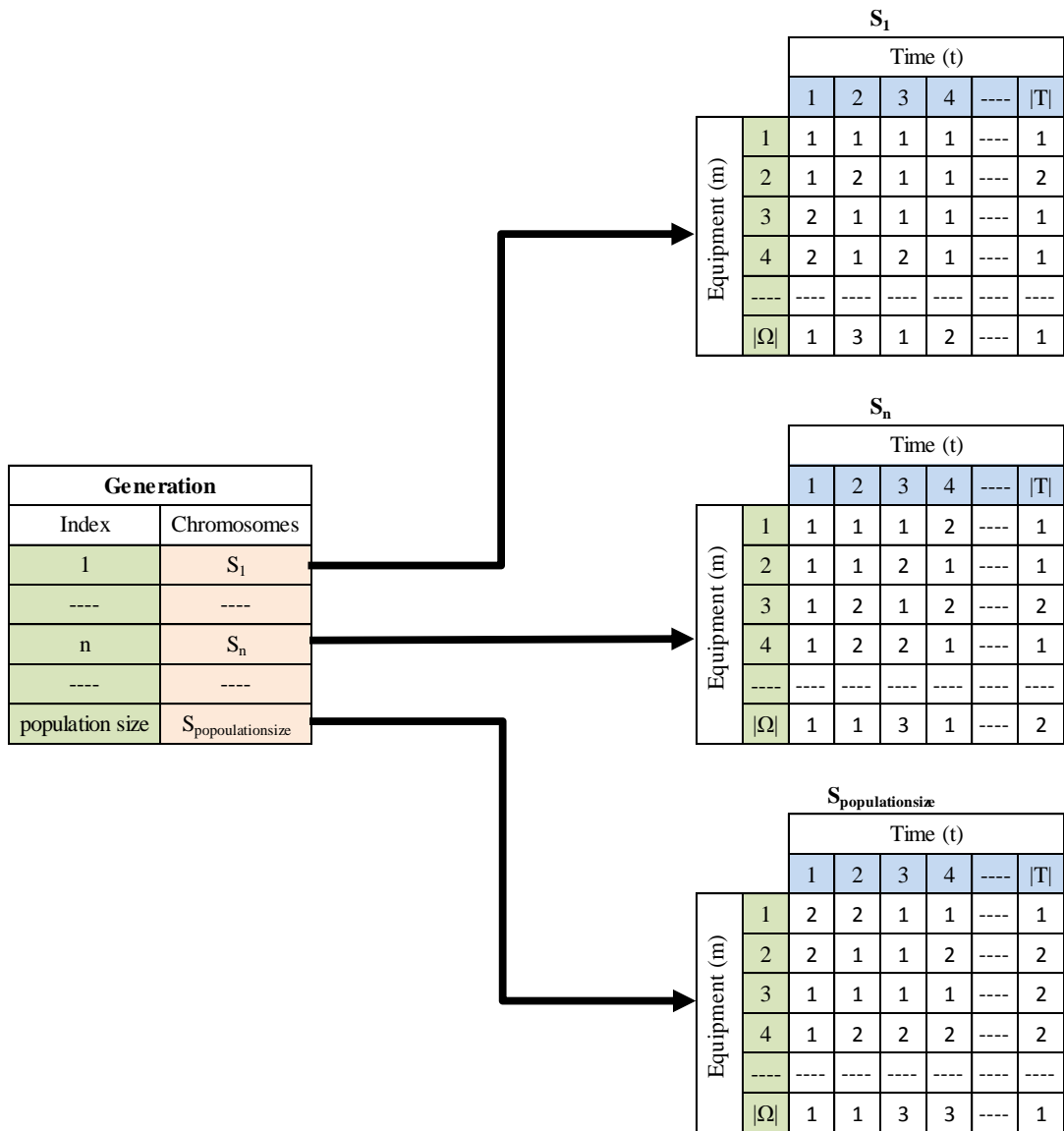

Figure 5-6: Population representation in a typical generation

### 5.6.3.2 Cost and reliability estimation:

For a given schedule,  $S$  as an individual chromosome in the population the expected total cost, ( $ETC$ ) is computed using Eq. (14) using the decision variable orientation

procedures outlined in Figure 5-4 and Figure 5-5. Similarly, we also estimate reliability for  $\epsilon$ -constraint method using Eq. (15).

### **5.6.3.3 Crossover and mutation:**

As discussed previously in Section 5.6.3.1, ‘ga’ procedure restricts a customized selection for crossover and mutation related parameters.

### **5.6.3.4 Stopping criterion:**

There are several stopping criteria that are employed with built-in ‘ga’ function in MATLAB (2015b). The details on the stopping criterion can be found in MATLAB (2015b)<sup>d</sup> Global Optimization Toolbox. We have selected the default stopping criterion, with the exception to two criteria: ‘Generations’ and ‘TolFun’. The selected values for these parameters are provided in Table 5-1.

## **5.7 Simulation Study**

### **5.7.1 Operational Risk-based Equipment Selection:**

Operational risk-based equipment selection process as discussed in Section 5.5 is applied to a section of gas sweetening unit as shown in Figure 5-2. The proposed operational risk-based equipment selection generated two categories of equipment as listed Table 5-3. From the operational risk analysis, it is evident that maintenance scheduling of all columns, drums and recontactor cannot be done unless the unit is planned for a shutdown and requires a shutdown maintenance strategy to develop the maintenance plan. Shutdown inspection and maintenance modeling has been presented by Hameed, and Khan (2014) and Hameed et al. (2014). On the other hand, for the remaining equipment maintenance scheduling can be

planned and optimized without shutting down the facility. The proposed model is applied to develop an optimized maintenance schedule for selected equipment considering facility non-shutdown maintenance strategy.

Table 5-3: Operational Risk-based Equipment Selection

Equipment requiring shutdown maintenance strategy	Equipment requiring non-shutdown maintenance strategy
Washing column	Wash water circulation pumps
Absorber	Skim oil pumps
HP recontactor	Makeup water pumps
LP recontactor	AFA pumps
HP flash drum	Drain pumps
LP flash drum	Rich sulfinol pumps
Drain drum	Lean sulfinol pumps

### 5.7.2 Equipment Failure Model:

Equipment failure history and repair data are generally stored in the maintenance management systems. Data from a LNG plant gas sweetening unit was analyzed and presented by Ahmed et al. (2015). In this study we use the same information. However, some of the data has been revised based on the information received from field engineers for some of the selected equipment. These data are presented in Table 5-4. Further, we have



considered 24 months of planning horizon to develop maintenance scheduling optimization strategy for the selected units.

Table 5-4: Failure Data

m	Equipment requiring non-shutdown maintenance strategy	$\lambda_m$ (failure/hr)	$\beta_m$	$\alpha_m$
1	Wash water circulation pumps	0.000436	1.2	0.4
2	Skim oil pumps	0.00029	1.9	0.6
3	Makeup water pumps	0.000152	2.5	0.6
4	AFA pumps	0.0001316	1.7	0.5
5	Drain pumps	0.0001104	1.8	0.4
6	Rich sulfinol pumps	0.00066	2.1	0.3
7	Lean sulfinol pumps	0.00075	1.9	0.3

### 5.7.3 Inspection and Maintenance Cost:

Majority of the published maintenance optimization model considers a time-based maintenance regardless of the condition of the equipment and follows a predefined interval by original equipment manufacturers. These pre-defined intervals set up set of activities in the form of work orders which is triggered automatically without considering the available resources and the shutdown of the system. In some cases multiple activities overlap and result in scheduling problems as well. Generally in Computerized Maintenance Management System (CMMS), data such as time required for completing a pre-defined inspection, maintenance, and replacement, as well as the cost of all associated skilled worker and required equipment is also stored and readily available for references. Table 5-5 present the

estimated cost (\$/event) related to failure ( $CF_m$ ), repair ( $CR_m$ ), maintenance ( $CM_m$ ) and inspection ( $CI_m$ ) for all considered equipment. These values are estimated using Eq. (5-8) to Eq. (5-11) and plant specific CMMS data and field personnel.

Table 5-5: Inspection and Maintenance Cost Data

M	$CF_m$ (\$/event)	$CR_m$ (\$/event)	$CM_m$ (\$/event)	$CI_m$ (\$/event)
1	970	480	190	20
2	1900	1080	190	20
3	1850	1050	190	48
4	1050	480	240	36
5	1000	450	240	36
6	800	320	180	45
7	800	320	200	40

#### 5.7.4 Numerical results:

Selected results of the solution run for developed model on the case study is presented in Table 5-6 and Table 5-7. The optimal maintenance schedule for the set of equipment, obtained from GA optimization procedure is presented in terms of corresponding Pareto Front as showed in Figure 5-7 within the objective function space. Pareto Front shown in the referred figure is comprised of 42 points i.e. a total of 42 possible optimal solutions of the objective functions. The Pareto front shown in Figure 5-7 is developed based on the 42 optimal solutions corresponding to the range of reliability from 0 to 0.99. The convergence graph clearly indicates that the cost increase exponentially when the target reliability is set to be more than 80% and is in line with the practical expectation. Higher cost associated with

higher level of reliability is due to the cost of frequent replacement; this is also reflected in the optimal schedule where frequency of replacement increases with increased reliability target. Appearance of successive replacement also observed in the schedule. It is understandable that in the extreme scenario of 100% target reliability, replacement (R) becomes the only option. When a plant can be operated with lower level of reliability, regular maintenance can be carried out instead of replacement. In the proposed methodology, the maintenance schedule is developed by minimizing the cost while considering variable target reliability. The user can then choose from a list of alternative schemes to decide maintenance schedule over a period of time considering budgetary constraints. Generally gas processing facility target to achieve and operate with the reliability in the range of 90% to 95%. Considering this, two maintenance schedule obtained using Pareto-front is presented in Table 5-6 and Table 5-7. The optimum schedule suggested by this integrated approach to achieve 90% system reliability produces a maintenance cost of \$34210 and for a 95% reliability results \$42926.75 for two years period. The optimized schedule is an outcome while maximizing reliability and minimizing cost. The Pareto frontier is representative of this fact. The failure model is developed using expected number of failures while estimating the maintenance cost. The outcome of the simulation run confirms that the inspection is not directly affecting the reliability. Hence, at lower level of reliability we expect more inspections and lower cost. In other case, maintenance and replacement is dominating, as they affect the reliability.

One of the outputs of the Pareto Front is that the analyst can select externally the best maintenance strategies considering various possible restrictions imposed over the solution simultaneously. Hence the analyst can analyze afterward every solution of each Pareto front

score based on reliability and cost. Additionally each of the 500 generation calculated in the front is related to specific schedule, so the decision maker can select a schedule of the Pareto front according to his or her preference knowing that the elected solution will accomplish all the imposed constraints. Maintenance and reliability team can effectively utilize the presented model to design maintenance activities such as inspection, maintenance and replacement to meet their organizational goals. Further in case of an equipment unexpected failures, the model need to be updated to develop a revised schedule for the remaining period.

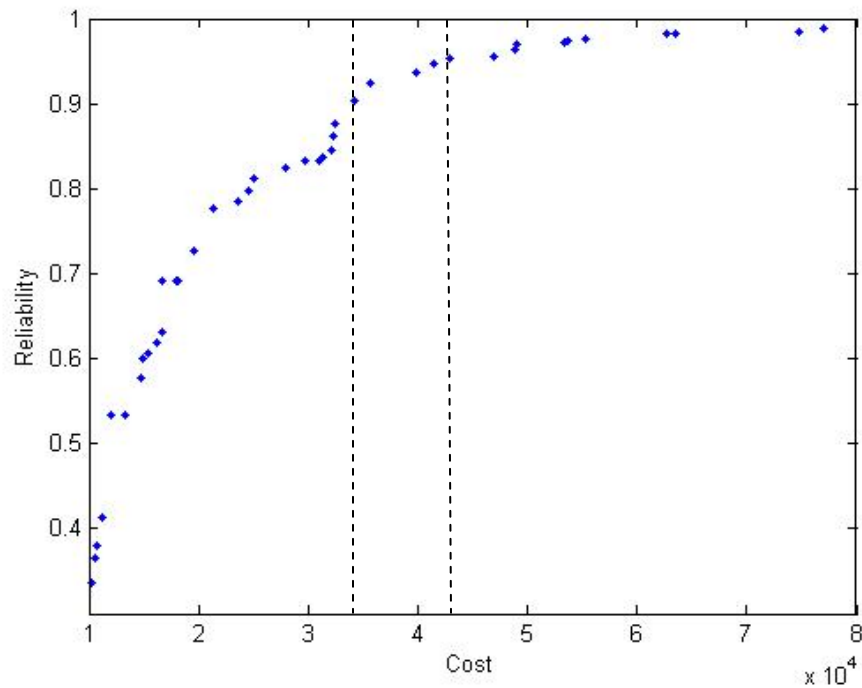

Figure 5-7: Pareto Front - Total Maintenance Cost Subject to Reliability Constraints

Table 5-6: Inspection and Maintenance Schedule for Target Reliability of 90%

**Total Cost = \$ 34210.55 and Reliability = 90.0%**

m	Planning Horizon (Month)																							
	1	2	3	4	5	6	7	8	9	10	11	12	13	14	15	16	17	18	19	20				
1	I	M	M	I	I	R	R	R	M	M	M	M	R	M	M	R	M	M	I	M	R	M	M	
2	I	M	M	I	I	M	I	I	I	R	M	M	M	R	M	I	M	M	I	I	M	I	M	I
3	I	R	I	M	R	M	M	I	I	M	M	R	M	M	I	I	R	M	I	M	M	M	M	M
4	I	M	M	M	I	M	M	I	I	M	I	R	M	I	I	I	I	I	I	I	M	I	I	I
5	I	I	R	M	M	I	I	I	M	M	M	M	M	M	M	M	M	I	M	M	M	I	I	M
6	I	M	M	M	I	R	M	I	R	M	R	M	M	M	M	M	R	M	R	M	M	R	R	M
7	I	M	R	M	M	M	R	M	R	M	M	I	R	M	M	M	I	M	R	R	M	I	M	M

Table 5-7: Inspection and Maintenance Schedule for Target Reliability of 95%

**Total Cost = \$ 42926.75 and Reliability = 95.0%**

m	Planning Horizon (Month)																							
	1	2	3	4	5	6	7	8	9	10	11	12	13	14	15	16	17	18	19	20				
1	I	R	M	M	M	M	I	R	M	M	M	R	M	R	I	M	R	I	R	M	M	M	M	M
2	I	R	M	M	M	M	M	R	M	R	M	I	I	I	R	M	M	R	M	M	M	I	I	M
3	I	M	M	M	M	M	R	M	M	R	I	M	R	I	R	I	M	R	M	M	R	R	M	M
4	I	M	R	I	M	I	M	M	I	M	I	M	R	M	M	M	M	I	I	I	I	M	I	I
5	I	I	R	I	R	M	I	I	M	M	M	M	R	M	M	I	M	M	I	R	M	I	I	I
6	I	M	M	R	M	M	M	M	R	R	M	M	M	R	R	M	M	R	R	I	R	M	M	M
7	I	M	R	R	M	R	M	M	R	M	R	R	R	M	M	M	R	M	M	I	R	M	M	M

## 5.8 Conclusions

This paper proposes a multi-constrained, bi-objective non-linear optimization models using GA for maintenance scheduling for a section of a sweetening unit of a hydrocarbon processing facility. The proposed simulation based approach presented in the study, provides an optimal schedule for inspection, maintenance and replacement activities to achieve a reliable performance of the facility considering the facility shutdown. A well planned maintenance schedule generated from the Pareto-optimal solution, such as presented here will not only help to reduce the overall maintenance cost, increase the reliability of the facility but also minimize unnecessary shutdown of the facility. Typically a shutdown of a LNG producing facility generates a significant financial impact, resulting in millions of dollars in loss of production. The developed risk-based equipment selection strategy helps to minimize such event of loss production due triggered from the shutdown for maintenance of the unit.

The proposed model has been successfully applied to obtain and optimize maintenance schedule for a gas sweetening unit, without provoking the facility shutdown. The proposed methodology, when extended to the complete plant will multiply the savings further, due to reduction in number of planned facility shutdown to maintain the desired reliability. Overall this methodology helps in developing an effective resource utilization planning. Pareto-optimal model provides flexibility to engineers and planners to develop maintenance schedules considering different conflicting objectives.

The overall results derived from the proposed optimization models confirm the applicability of the approach to real world maintenance scheduling optimization problem and its application to other asset intensive industries where these actions are important to ensure

safety, availability and reliability of the facilities. The proposed optimization methodology can be applied to any facility such as process or non-process.

In the future work, proposed methodology can be extended to solve non-linear optimization problem for maintenance scheduling with many other meta-heuristics such as Harmony Search algorithm, Tabu Search, and Simulated Annealing. This can assist in benchmarking the performance of the proposed GA with the other meta-heuristics. This problem of scheduling can also be revisited considering inflationary conditions as well. The current model has risk-neutral analysis to the problem, and interesting future work could be used to customize the schedule, based on the firm's risk tolerance attitude.

## **Chapter6**

### **Conclusion, Contributions and future work**

#### **6.1 Introduction**

The development of an optimal shutdown interval for inspection and maintenance considering the uncertainty surrounding the age-based wear-out or degradation of systems or equipment is vital for the safe operation of a processing plant. A carefully planned inspection and maintenance strategy not only mitigates the effect of age based degradation but also reduces the threat of risk exposure. During the operational life of a facility, the only way to prevent component failure is through optimal maintenance strategy which can facilitate inspection, repair, overhaul or replacement. Some of the maintenance and inspection activities can be completed while the processing unit is in operations; however some of the equipment requires the processing unit to be in a non-operational state, usually called shutdown. These maintenance and inspection activities involve cost, shutdown, and a likelihood of having a reduced life due to induced human error. If the interval between subsequent shutdown, maintenance and inspection tasks is too long, it may result in a number of premature failures of components, which will result in higher economic consequences. On the other hand, if the shutdown maintenance and inspection is performed very often, it will not only increase the overall cost but also the possibility of induced human error. This is why a careful inspection and maintenance shutdown interval is required. Finding an optimal



shutdown interval, after taking into consideration the uncertainty, is a challenging task. Failures due to wear-out, corrosion, erosion etc., can be modeled stochastically. Existing maintenance strategies e.g., preventive maintenance, and condition based maintenance are formulated on the probability of component failure only. However, the risk-based maintenance and inspection strategy is a new paradigm change. A risk-based methodology not only considers the probability of a failure of the equipment but also the possible consequences of the failure. The economic consequences of a failure include the cost of breakdown, production loss due to facility shutdown, consequence of environmental damage, consequence of asset damage and cost of liability. Inspection and maintenance tasks inherently have economic consequences such as cost of inspection, cost of repair, cost of technical support, cost of replacement parts, labor and equipment cost. Keeping in mind the importance of the probability of failure and its consequences, the risk based inspection and maintenance strategy proposed in this thesis provides a legitimate choice for the decision making process regarding the shutdown interval. In this proposed work, the reduction of risk to a reasonably low and practicable level is considered to ensure that the risk-based shutdown inspection and maintenance strategy maintains the safety of operations through the optimal utilization of resources. The proposed optimization methodology is a trade-off between the cost of failure, shutdown and the benefits of risk reduction, achieved by the optimal shutdown interval in terms of increased safety, availability and reliability.

## **6.2 Research Contributions**

In this proposed research, a methodology is developed and presented to estimate and manage the shutdown of complex processing units or facilities which operate on a 24 hours

and 365 days basis. The decision to shut-down a unit or facility is an important and a key decision for operating companies as this may produce a severe negative impact on their financial health. However, the benefits of having a best planned shutdown strategy will not only help to achieve high availability and reliability, low maintainability, and low overall cost but importantly will also minimize the operational risk. The availability of very limited shutdown modeling for inspection and maintenance for processing facilities provides us an opportunity to work on this topic, and to develop methodologies that can be applied and used to benefit operating companies in achieving their financial objectives. As discussed earlier, reliability, availability and cost are the three facet of risk.

The major contributions of this research are summarized as follows:

- ***A framework to estimate the risk-based shutdown interval for a processing plant***

Asset intensive industries such as oil and gas and petrochemical plants operate on a continuous basis. Planning inspection on maintenance on individual equipment will result in a significant impact on the operability as well as financial losses to the shareholders. In order to minimize these impacts, a frame work to estimate shutdown inspection and maintenance interval estimation on risk-based strategy is developed. This research analyzes the unit or facility by developing a risk-based equipment selection considering risk. The proposed research outlines the risk by estimating consequences considering various hazards. The proposed methodology is applied to develop shutdown interval for a LNG producing unit.

- ***A risk-based methodology to estimate shutdown interval considering system availability***

A novel risk-based approach to estimate the shutdown inspection and maintenance interval considering system availability using Markov process is presented. The proposed methodology reduces the risk of exposure to the operating company and shareholders for planning facility shutdown by maintaining the desired availability. This methodology ensures that the unit or plant is not only available for production but also the overall risk exposure meets the acceptance criteria. Considering and minimizing risk while planning for shutdown interval not only enhances the availability but also the safety and operation of the facility. The proposed methodology minimizes the financial consequences for an operating company due to production loss, loss of assets, safety (e.g., injury or loss of life) and environmental consequences.

- ***A risk-based shutdown inspection and maintenance interval considering human error for a processing facility***

Repair is the maintenance action that restores the equipment to its operating conditions. Some repair actions restore equipment to a new condition while others are classed as minimal repair, i.e., they restore equipment to the condition prior to its failure. However, in reality, an equipment is likely to be restored to a condition between these two states. Occasionally, repairs may introduce faults in the equipment. A majority of the maintenance models find the optimum maintenance and inspection interval under the assumption that after maintenance action, the system or equipment state will be as good as new. Other researchers have studied the impact of imperfect maintenance while optimizing the maintenance and inspection interval. However, in both the cases the optimization is performed considering individual equipment and

the impact of facility shutdown while optimizing the maintenance and inspection interval is not taken into account. The novel idea presented in this work is to link various mechanics which can induce human error during inspection and maintenance activities. SLIM methodology is deployed to estimate HEP for each set of inspection and maintenance activities. Estimated HEP is then integrated in the probability of system failure. Shutdown inspection and maintenance consequences of selected equipment are determined and expressed in financial values (\$). Integration of HEP results in obtaining a better risk profile, which is later used to optimize the shutdown interval.

- ***Risk-based maintenance scheduling for a LNG gas sweetening unit***

The previous three proposed articles help to develop an optimized shut down inspection and maintenance interval for the operating facility. In this paper, a multi-constrained, bi-objective maintenance scheduling optimization model is proposed using genetic algorithms. The genetic algorithm model was developed using MATLAB (Version 2015b) to solve this non-linear optimization problem. The proposed simulation based approach presented in the study, provides an optimal schedule for inspection, maintenance and replacement activities to achieve a reliable performance of the facility considering, the facility shutdown. Inspection, maintenance and replacement are considered as the three possible sets of activities to develop the schedule. Overall, this methodology helps in developing an effective planning for resource utilization. The developed Pareto-optimal model provides flexibility to engineers and planners to develop maintenance schedules considering different conflicting objectives.

### 6.3 Conclusions

Inspection and maintenance optimization using mathematical modeling and simulation of the stochastic process is a growing area of research. A critical review of literature shows that there is a need for a robust risk-based inspection and maintenance model considering the process plant shutdown to help make an informed decision. In this dissertation, new models, approaches and algorithms have been explored to estimate and manage the shutdown interval for complex hydrocarbon processing units.

The risk of equipment failure and its consequences on availability and reliability are vital for the hydrocarbon industry. In order to achieve a desired reliability and availability, these units are mostly taken out of service, i.e., put on “shutdown”. If the shutdown of the unit or facility is not planned considering the risk, it will produce a severe negative financial impact on the operating companies and their shareholders. By combining the probability of failure and the consequences of failure, an optimal strategy is proposed for developing shutdown interval.

The inspection and maintenance management and optimization is encouraging operating companies and engineers to invest efforts in this domain to meet the availability and reliability of the facilities. However, the emphasis is found to be very limited when planning for shutdown of the facility and is generally based on Original Equipment Manufacturer (OEM) suggested intervals. The aim of this proposed risk-based shutdown strategy for a processing facility is to provide an optimal interval. This optimal shutdown interval will not only improve the reliability and availability of the plant but will also protect human life, financial investment and the environment.

The key areas covered in this research include efforts to develop a risk-based framework for shutdown interval modeling, risk-based shutdown interval optimization considering required availability, integrating human errors in shutdown interval optimization model, and finally developing a risk-based maintenance schedule for the facility, considering shutdown.

In conclusion, the proposed methodologies will contribute to processing plant industries in providing a methodology for shutdown interval optimization. Most important, the proposed methodology not only takes account the uncertainty and variability by using stochastic modeling but also the economic consequence of failure.

In conclusion, it is envisaged that this research will effectively contribute to the field by providing a wide range of solutions to industry in terms of shutdown interval estimation and management. This proposal is an attempt to overcome the shortcomings of the existing methodologies published in the literature, which fail to capture the impact of overall facility shutdown in long duration operations. In this work an attempt has been made to overcome the said limitation and provide a novel solution to optimize shutdown interval with a risk-based approach.

#### **6.4 Recommendations for future research work**

Inspection and maintenance optimization is in focus since the last few decades. However, consideration of shutdown interval for inspection and maintenance is found to be very limited in literature. In this proposed research, a methodology to develop shutdown interval for a processing facility is presented considering the risk, availability, reliability, imperfect maintenance and finally genetic algorithms are applied to develop a maintenance

schedule. Along with the key development, there is always an option to enhance or extend the proposed work. Some of the suggestions are discussed in this section.

1. In the presented research, a risk profile is developed considering the consequences due to safety hazards, production loss and inspection and maintenance costs. Generally, operating companies operate with the resources which can meet their ongoing operations, however for shutdown they need to hire additional manpower, tools and purchase spares. This work can be extended to optimize shutdown interval optimization including other constraints such as inspection and maintenance manpower, tools and spares availability and their financial impact on shutdown planning. Consideration of these in generating a risk profile will provide a better insight into the optimization problem.

2. In the present work a risk-based shutdown interval methodology is explored considering the availability of the facility. Here, the proposed methodology has considered a constant failure and repair rate in determining a steady state availability to obtain the risk-based shutdown interval. This work can be extended to develop state dependent models with different failure behaviors. The flexibility of state-dependent models will help to develop various failure modes that will result in obtaining a better representation of the situation.

3. A planned shutdown helps in utilizing the available resources to minimize the operational risk. For any shutdown planning, multiple tasks can be considered such as no action can be planned on certain equipment of the facility, and/or the equipment is left to operate and continues to age with the same failure rate. An inspection, maintenance and repair action may be scheduled and in some cases a decision may be made to replace the equipment. These tasks will generate a detailed shutdown schedule for the considered equipment. Developing a detailed time schedule for a specific shutdown will help taking

account the uncertainties in completing these tasks and will lead to forecasting the actual shutdown duration. This in turn will help the operating companies to adjust their risk tolerance considering the impact of their delivery schedule and commitments.

4. Shutdown interval optimization for inspection and maintenance is considered to ensure the safety, reliability, and availability of the units and the facility. In this research, a simulation based Pareto-optimal solutions using genetic algorithms for multi-constrained maintenance scheduling optimization are discussed for the equipment which can be inspected and maintained without taking the facility in shutdown. The proposed methodology can be extended to solve non-linear optimization problems for shutdown maintenance scheduling with meta-heuristics such as Harmony Search algorithm (Geem, Kim, & Loganathan, 2001), Tabu Search (Glover, 1998), and Simulated Annealing (Kirkpatrick, 1984), etc.

5. Further, the shutdown interval optimization problem can be coupled with inflationary conditions to generate a risk profile for shutdown interval planning and decision making.



## REFERENCES

### 7.1 References - Chapter 1

- [1] Dhillon, B.S., (2002). Engineering maintenance, A Modern approach. CRC Press LLC, 2000 N.W. Corporate Blvd., Boca Raton, Florida 33431.
- [2] Duffua, S.O., Raouf, A., & Campbell, J., (1999). Maintenance planning and control, modeling and analysis. Wiley, New York, N.Y.
- [3] Duffua, S.O. & Daya M.A.B., (2004). Turnaround maintenance in petrochemical industry, practice and suggested improvement. Journal of Quality in Maintenance Engineering, 10(3), 184-190.
- [4] Ebeling, C. E., (1996). An Introduction to Reliability and Maintainability Engineering. 2nd edition, McGraw-Hill
- [5] Lawrence, G., (2012). Cost estimating for turnarounds: Petroleum Technology quarterly. Q1-2012. [www.eqtq.com](http://www.eqtq.com).
- [6] Gulati, R., & Smith, R., (2009). Maintenance and Reliability Best Practices. Industrial Press, Inc., 989 Avenue of the Americas New York, NY 10018.
- [7] International atomic energy association, (2004). IAEA-TECDOC-1387, Safety considerations for research reactors in extended shutdown, IAEA, VIENNA, Austria
- [8] Kaplan, S., & Garrick, B.S., (1981). On the quantitative definition of risk, Risk Analysis, 1, 11-27.
- [9] Kobbacy, K.A.H, & Murthy, D.N.P., (2008). A complex system maintenance handbook. Springer Series in Reliability Engineering, Springer-Verlang London Limited.

- [10] Stephens, M.P., (2010). Productivity and Reliability-Based Maintenance Management, Purdue University Press, USA.
- [11] Telang, A.D. & Telang, A., (2010). Comprehensive Maintenance Management, Policies, Strategies and Option; PHI Learning, ISBN – 978-81-203-3953-8.

## **7.2 References - Chapter 2**

- [1] API., (2009). Risk Based Inspection; Recommended Practice 580 (2nd ed.), Washington, D.C., USA: American Petroleum Institute.
- [2] API., (2008). Risk Based Inspection; Recommended Practice 581 (2nd ed.), Washington, D.C., USA: American Petroleum Institute.
- [3] Assael, M. J., & Kakosimos, K. E., (2010). Fires explosions and toxic gas dispersion; Effects calculation and risk analysis. Broken Sound Parkway NW, Boca Raton, FL, USA: CRC Press, Taylor & Francis Group.
- [4] Cizelj, R. J., Mavko, B., & Kljenak, I., (2001). Component reliability assessment using quantitative and qualitative data. Reliability Engineering and System Safety, 71, 81-95.
- [5] Crowl, D. A., & Louvar, J. F., (2002). Chemical process safety: Fundamentals with applications. Upper Saddle River, New Jersey, USA: Prentice Hall PTR.
- [6] Duarte, J. A. C., Craveiro, J. C. T., & Trigo, T. P., (2006). Optimization of the preventive maintenance plan of a series components system. International Journal of Pressure Vessel and Piping, 83, 244-248.

- [7] Duffua, S. O., & Ben-Daya, M. A. B., (2004). Turnaround maintenance in petrochemical industry; practice and suggested improvement. *Journal of Quality in Maintenance Engineering*, 10(3), 184-190.
- [8] Duffua, S. O., Raouf, A., & Campbell, J. D., (1999). *Planning and control of maintenance system, modeling and analysis*. New York, N.Y., USA: John Wiley & Sons, Inc.
- [9] Ebeling, C. E., (1997). *An introduction to reliability and maintainability engineering*. New York, N.Y., USA: McGraw-Hill.
- [10] Fujiyama, K., Nagai, S., Akikuni, Y., Fujiwara, T., Furuya, K., & Matsumoto, S., (2004). Risk-based inspection and maintenance system for steam turbine. *International Journal of Pressure Vessel and Piping*, 81, 825-835.
- [11] Ghosh, D., & Roy, S., (2009). Maintenance optimization using probabilistic cost-benefit analysis. *Journal of Loss Prevention in the Process Industry*, 22, 403-407.
- [12] Hadavi, S. M. H., (2009). A heuristic model for risk and cost impacts of plant outage maintenance schedule. *Annals of Nuclear Energy*, 36, 947-987.
- [13] Judycki, D. C., (1994). *Technical advisory on motor vehicle accident costs*. US Department of Transportation, Federal Highway Administration.  
[http://safety.fhwa.dot.gov/facts\\_stats/t75702.cfm](http://safety.fhwa.dot.gov/facts_stats/t75702.cfm) Accessed 20.12.12.
- [14] Keshavarz, G., Thodi, P., & Khan, F., (2011). Risk based shutdown management of LNG units. *Journal of Loss Prevention in the Process Industries*, 25, 159-165.
- [15] Khan, F. I., & Haddara, M., (2003). Risk-based maintenance (RBM): a quantitative approach for maintenance/inspection scheduling and planning. *Journal of Loss Prevention in the Process Industries*, 16, 561-573.

- [16] Khan, F. I., & Haddara, M., (2004)<sup>a</sup>. Risk-Based Maintenance (RBM): a new approach for process plant inspection and maintenance. *Process Safety Progress*, 23(4), 252-265.
- [17] Khan, F. I., & Haddara, M., (2004)<sup>b</sup>. Risk-based maintenance of ethylene oxide production facilities. *Journal of Hazardous Materials*, 108, 147-159.
- [18] Krishnasamy, L., Khan, F., & Haddara, M., (2005). Development of risk-based maintenance (RBM) strategy for a power generating plant. *Journal of Loss Prevention in the Process Industries*, 18, 69-81.
- [19] Lawrence, G., (2012). Cost estimating for turnarounds: *Petroleum Technology quarterly*. Q1-2012. [www.eqtq.com](http://www.eqtq.com).
- [20] Lenahan, T., (1999). *Turnaround management*. Oxford, MA, UK: Butterworth-Heinemann.
- [21] Levitt, J., (2004). *Managing maintenance shutdowns and outages* (1st ed.). New York, N.Y., USA: Industrial Press.
- [22] Muhlbauer, W. K., (2004). *Pipeline risk management manual, ideas, techniques, and resources* (3rd ed.). Burlington, MA, USA: Gulf Professional Publishing.
- [23] Noortwijk, J. M., Dekker, R., Cooke, R. M., & Mazzuchi, T. A., (1992). Expert judgment in maintenance optimization. *IEEE Transactions on Reliability*, 41(3), 427-432.
- [24] Obiajunwa, C., (2012). A framework for the evaluation of turnaround maintenance projects. *Journal of Quality in Maintenance Engineering*, 18(4), 368-383.
- [25] OREDA (2002). *Offshore reliability data* (4th ed.), Trondheim, NORWAY.

- [26] Pokharel, S., & Jiao, J., (2008). Turnaround maintenance management in a processing industry, a case study. *Journal of Quality in Maintenance Engineering*, 14(2), 109-122.
- [27] Rusin, A., & Wojaczek, A., (2012). Optimization of Power Machines maintenance intervals taking the risk into consideration. *Eksploatacja i Niezawodnosce Maintenance and Reliability*, 14(1), 72-76.
- [28] Schon, G., (1980). What is meant by risk? Basic technical views for the initiation and application of safety legislation. *Journal of Occupational Accidents*, 2, 273-281.
- [29] Tam, S. B., Chan, W. M., & Price, J. W. H., (2006). Optimal maintenance intervals for a multi-component system: production planning & control. *The Management of Operations*, 17(8), 769-779.
- [30] Tan, J. S., & Kramer, M. A., (1997). A general framework for preventive maintenance optimization in chemical process operations. *Computers and Chemical Engineering*, 21(12), 1451-1469.
- [31] U.S. Energy Information Administration, (2012). LNG Price. Retrieved from <http://www.eia.gov/dnav/ng/hist/n9103us3m.htm> Accessed 30.09.12.
- [32] Vatn, J., Hokstand, P., & Bodsberg, L., (1996). An overall model for maintenance optimization, *Reliability Engineering & System Safety*, 51(3), 241–257.
- [33] Vaurio, J.K., (1995). Optimization of test and maintenance intervals based on risk and cost, *Reliability Engineering and System Safety*, 49(1), 23–36.
- [34] Zulkipli, G., Halib, M., Nordin, S. M., & Ghazali, M. C., (2009). Rusty bolts and broken valves: a study on the plant technology, size, and organizational structure of

plant turnaround maintenance in Malaysian process-based industries. *International Review of Business Research Papers*, 5(5), 239-256.

### **7.3 References - Chapter 3**

- [1] Alabdulkarem, A., Mortazavi, A., Hwang, Y., Radermacher, R., & Rogers, P., (2011). Optimization of propane pre-cooled mixed refrigerant LNG plant. *Applied Thermal Engineering*, 31, 1091–1098.
- [2] Alsyouf, I., (2007). The role of maintenance in improving companies, productivity and profitability. *International Journal of Production Economics*, 105 (1), 70–78.
- [3] API, (2009). *Risk Based Inspection: Recommended Practice 580*, Second ed. American Petroleum Institute, Washington, D.C.,USA.
- [4] Assael, M. J., & Kakosimos, K. E., (2010). *Fires explosions and toxic gas dispersion; Effects calculation and risk analysis*. Broken Sound Parkway NW, Boca Raton, FL,USA: CRC Press, Taylor & Francis Group.
- [5] Backlund, F., & Hanu, J., (2002). Can we make maintenance decision on risk analysis?. *Journal of Quality in Maintenance Engineering*, 8 (1), 77-91.
- [6] Bertolini, M., Bevilacqua, M., Ciarapica, F.E., & Giacchetta, G., (2009). Development of Risk-Based Inspection and Maintenance procedures for an oil refinery. *Journal of Loss Prevention in the Process Industries*, 22, 244–253.
- [7] Cizelj, R. J., Mavko, B., & Kljenak, I., (2001). Component reliability assessment using quantitative and qualitative data. *Reliability Engineering and System Safety*, 71, 81-95.

- [8] Crowl, D. A., & Louvar, J. F. (2002). *Chemical process safety: Fundamentals with applications*. Upper Saddle River, New Jersey, USA: Prentice Hall PTR.
- [9] Dey, K.P., Ogunlana, S.O., Gupta, S.S., & Tabucanon, M.T., (1998). A risk-based maintenance model for cross-country pipelines. *Cost Engineering*, 40 (4), 24–31.
- [10] Dey, P.M., (2001). A risk-based model for inspection and maintenance of cross-country petroleum pipeline. *Journal of Quality in Maintenance Engineering*, 7 (1), 25–41.
- [11] Duarte, J.A.C., Craveiro, J.C.T., & Trigo, T.P., (2006). Optimization of the preventive maintenance plan of a series components system. *International Journal of Pressure Vessels and Piping*, 83, 244–248.
- [12] Duffua, S. O., & Ben-Daya, M. A. B., (2004). Turnaround maintenance in petrochemical industry; practice and suggested improvement. *Journal of Quality in Maintenance Engineering*, 10(3), 184-190.
- [13] Duffua, S. O., Raouf, A., & Campbell, J. D., (1999). *Planning and control of maintenance system, modeling and analysis*. New York, N.Y., USA: John Wiley & Sons, Inc.
- [14] Ebeling, C. E. (1997). *An introduction to reliability and maintainability engineering*. New York, N.Y., USA: McGraw-Hill.
- [15] Fujiyama, K., Nagai, S., Akikuni, Y., Fujiwara, T., Furuya, K., Matsumoto, S., Takagi, K., & Kawabata, T., (2004). Risk-based inspection and maintenance system for steam turbine. *International Journal of Pressure Vessels and Piping*, 81, 825–835.
- [16] Ghosh, D., & Roy, S. (2009). Maintenance optimization using probabilistic cost-benefit analysis. *Journal of Loss Prevention in the Process Industry*, 22, 403-407.

- [17] Jacob, D., & Amari, S., (2005). Analysis of complex repairable systems. *Institute of Electrical and Electronics Engineers*, 54, 517–529.
- [18] Judycki, D.C., (1994). Technical Advisory on Motor Vehicle Accident Costs. US Department of Transportation, Federal Highway Administration, USA. <http://safety.fhwa.dot.gov/facts stats/t75702>, Accessed on December 20, 2012.
- [19] Keshavarz, G., Thodi, P., & Khan, F., (2011). Risk based shutdown management of LNG units. *Journal of Loss Prevention in the Process Industries*, 25, 159-165.
- [20] Khan F. I., & Haddara, M., (2004)<sup>a</sup>. Risk-Based Maintenance (RBM): A new approach for process plant inspection and maintenance. *American Institute of Chemical Engineers Process Safety Progress*, 23(4), 252-265.
- [21] Khan, F. I., & Haddara, M., (2003). Risk-based maintenance (RBM): A quantitative approach for maintenance/inspection scheduling and planning. *Journal of Loss Prevention in the Process Industries*, 16, 561-573.
- [22] Khan, F.I., & Haddara, M., (2004)<sup>b</sup>. Risk-based maintenance of ethylene oxide production facilities. *Journal of Hazardous Materials*, 108(3), 147–159.
- [23] Khan, F.I., Haddara, M., & Krishnasamy, L., (2008). A new methodology for risk-based availability analysis. *IEEE Transactions on Reliability*, 57, 103–112.
- [24] Krishnasamy, L., Khan, F.I., & Haddara, M., (2005). Development of risk-based maintenance (RBM) strategy for a power generating plant. *Journal of Loss Prevention in the Process Industries*, 18, 69-81.
- [25] Kumar, E.V., & Chaturvedi, S.K., (2008). Prioritization of maintenance tasks on industrial equipment for reliability. *International Journal of Quality & Reliability Management*, 28 (1), 109–126.



- [26] Lawrence, G., (2012). Cost estimating for turnarounds: *Petroleum Technology quarterly*. Q1-2012. [www.eqtq.com](http://www.eqtq.com), Last accessed on August 5, 2014.
- [27] Lenahan, T., (1999). *Turnaround management*. Oxford, MA, UK: Butterworth-Heinemann.
- [28] Levitt, J., (2004). *Managing maintenance shutdowns and outages* (1st ed.). New York, N.Y., USA: Industrial Press.
- [29] Mannan, S., (2005). *Lee's Loss Prevention in the Process Industries: Hazard Identification. Assessment and Control, Vol. 1, Third Edition*, Elsevier Butterworth\_Heinemann, Burlington, MA.
- [30] Mokhatab, S., & Economides, M.J., (2006). Onshore LNG production process selection, SPE Annual Technical Conference and Exhibition, San Antonio, TX, September 24–27.
- [31] Mourbray, J., (1997). *An Introduction to Reliability Centered Maintenance*, Butterworth-Heinemann, Oxford.
- [32] Muhlbauer, W. K., (2004). *Pipeline risk management manual, ideas, techniques, and resources* (3rd ed.). Burlington, MA, USA: Gulf Professional Publishing.
- [33] NASA, (2000), *The National Aeronautics and Space Administration: Reliability-Centered Maintenance Guide for Facilities and Collateral Equipment*, NASA, Washington, DC.
- [34] Neil, M., & Marquez, D., (2012). Availability modeling of repairable systems using Bayesian networks, *Engineering Applications of Artificial Intelligence*, 25(4) ,698-704.

- [35] Nowlan, F.S., & Heap, W., (1978). Reliability Centered Maintenance, US Department of Commerce, National Technical Information Services, Springfield, VA.
- [36] OREDA, (2002). Offshore reliability data (4th ed.), Trondheim, NORWAY.
- [37] Penrose, H.W., (2009). Simple time-to-failure estimation techniques for reliability and maintenance of equipment, IEEE Electrical Insulation Magazine, 25(4), 14–18.
- [38] Pil, C.K., Rausand, M., & Vatn, J., (2008). Reliability assessment of reliquefaction systems on LNG carriers. Reliability Engineering & System Safety, 93(9), 1345-1353.
- [39] Roberts, M.J., & Agrawal, R., (2001). Hybrid Cycle for the Production of Liquefied Natural Gas. US Patent 6,308,531.
- [40] Rusin, A., & Wojaczek, A., (2012). Optimization of Power Machines maintenance intervals taking the risk into consideration. Eksploatacja i Niezawodnosce Maintenance and Reliability, 14(1), 72-76.
- [41] Sarkar, A., & Behera, D.K., (2012). Development of risk based maintenance strategy for gas turbine power system. International Journal of Advanced Research in Engineering and Applied Science, 1 (2), 20–38.
- [42] Schon, G., (1980). What is meant by risk? Basic technical views for the initiation and application of safety legislation. Journal of Occupational Accidents, 2, 273-281.
- [43] Tan, J.S., & Kramer, M.A., (1997). A general framework for preventive maintenance optimization in chemical process operations. Computers & Chemical Engineering, 21(12), 1451–1469.
- [44] U.S. Energy Information Administration, (2012). LNG Price. Retrieved from <http://www.eia.gov/dnav/ng/hist/n9103us3m.htm> Accessed 30.09.12.

- [45] Vatn, J., Hokstand, P., & Bodsberg, L., (1996). An overall model for maintenance optimization. *Reliability Engineering & System Safety*, 51(3), 241–257.
- [46] Vaurio, J.K., (1995). Optimization of test and maintenance intervals based on risk and cost. *Reliability Engineering and System Safety*, 49(1), 23–36.
- [47] Wang, Y., Cheng, G., Hu, H., & Wu, W., (2012). Development of a risk-based maintenance strategy using FMEA for a continuous catalytic reforming plant. *Journal of Loss Prevention in the Process Industries*, 25(6) ,958–965.
- [48] Zhaoyang, T., Jianfeng, L., Zongzhi, W., Jianhu, Z., & Weifeng, H., (2011). An evaluation of maintenance strategy using risk based inspection. *Safety Science*, 49(6), 852–860.

#### **7.4 References - Chapter 4**

- [1] Alsyouf, I., (2007). The role of maintenance in improving companies, productivity and profitability. *International Journal of Production Economics*, 105 (1), 70–78.
- [2] API, (2009). *Risk Based Inspection: Recommended Practice 580*. Second ed. American Petroleum Institute, Washington, D.C.,USA.
- [3] Backlund, F., & Hanu, J., (2002). Can we make maintenance decision on risk analysis?. *Journal of Quality in Maintenance Engineering*, 8 (1), 77-91.
- [4] Ben-Daya, M., & Alghamdi, A.S., (2000). On an imperfect preventive maintenance model. *International Journal of Quality & Reliability Management*, 17(06), 661–670.
- [5] Bertolini, M., Bevilacqua, M., Ciarapica, F.E., & Giacchetta, G., (2009). Development of Risk-Based Inspection and Maintenance procedures for an oil refinery. *Journal of Loss Prevention in the Process Industries*, 22, 244–253.

- [6] Block, H.W., Borges, W.S., & Savits, T.H., (1985). Age dependent minimal repair. *Journal of Applied Probability*, 22 (2), 370–385.
- [7] Brown, M., & Proschan, F., (1983). Imperfect repair. *Journal of Applied Probability*, 20, 851–859.
- [8] Dey, K.P., Ogunlana, S.O., Gupta, S.S., & Tabucanon, M.T., (1998). A risk-based maintenance model for cross-country pipelines. *Cost Engineering*, 40 (4), 24–31.
- [9] Dey, P.M., (2001). A risk-based model for inspection and maintenance of cross-country petroleum pipeline. *Journal of Quality in Maintenance Engineering*, 7 (1), 25–41.
- [10] Dhillon, B.S., & Liu, Y., (2006). Human error in maintenance: a review. *Journal of Quality in Maintenance Engineering*, 12 (1), 21–36.
- [11] Dhillon, B.S., & Yang, N., (1995). Probabilistic analysis of a maintainable system with human error. *Journal of Quality in Maintenance Engineering*, 1(2), 50–59.
- [12] Dhillon, B.S., (1986). *Human Reliability with Human Factor*. Pergamon Press, New York, USA.
- [13] Duarte, J.A.C., Craveiro, J.C.T., & Trigo, T.P., (2006). Optimization of the preventive maintenance plan of a series components system. *International Journal of Pressure Vessels and Piping*, 83, 244–248.
- [14] Duffua, S.O., & Ben-Daya, M.A., (2004). Turnaround maintenance in petrochemical industry, practice and suggested improvement. *Journal of Quality in Maintenance Engineering*, 10 (3), 184–190.

- [15] Fujiyama, K., Nagai, S., Akikuni, Y., Fujiwara, T., Furuya, K., Matsumoto, S., Takagi, K., & Kawabata, T., (2004). Risk-based inspection and maintenance system for steam turbine. *International Journal of Pressure Vessels and Piping*, 81, 825–835.
- [16] Ghosh, D., & Roy, S., (2009). Maintenance optimization using probabilistic cost-benefit analysis. *Journal of Loss Prevention in the Process Industries*, 22(4), 403–407.
- [17] Hameed, A., Khan, F., & Ahmed, S., (2014). A risk-based methodology to estimate shutdown interval considering system availability. *Process Safety Progress*, 34(3), 267-279. <http://dx.doi.org/10.1002/prs.11722>.
- [18] Hameed, A., & Khan, F., (2014). A framework to estimate the risk-based shutdown interval for a processing plant. *Journal of Loss Prevention in the Process Industries*, 32, 18–29.
- [19] Jacob, D., & Amari, S., (2005). Analysis of complex repairable systems. *Institute of Electrical and Electronics Engineers*, 54, 517–529.
- [20] Judycki, D.C., (1994). Technical Advisory on Motor Vehicle Accident Costs. US Department of Transportation, Federal Highway Administration, USA. <http://safety.fhwa.dot.gov/facts stats/t75702>.
- [21] Khan, F.I., & Haddara, M., (2004)<sup>a</sup>. Risk-based maintenance (RBM): anew approach for process plant inspection and maintenance. *Process Safety Progress*, 23 (4), 252–265.
- [22] Khan, F.I., & Haddara, M., (2004)<sup>b</sup>. Risk-based maintenance of ethylene oxide production facilities. *Journal of Hazardous Materials*, 108(3), 147–159.

- [23] Khan, F.I., & Haddara, M., (2003). Risk-based maintenance (RBM); a quantitative approach for maintenance/inspection scheduling and planning. *Journal of Loss Prevention in the Process Industries*, 16(6), 561–573.
- [24] Khan, F.I., Haddara, M., & Krishnasamy, L., (2008). A new methodology for risk-based availability analysis. *IEEE Transactions on Reliability*, 57, 103–112.
- [25] Kirwan B., (1996). The validation of three Human Reliability Quantification techniques – THERP, HEART and JHEDI; Part 1 – technique descriptions and validation issues. *Applied Ergonomics*, 27(6), 359-373.
- [26] Kirwan, B., (1997). The validation of three human reliability quantification techniques—THERP, HEART and JHEDI; part III—practical aspects of the usage of the techniques. *Applied Ergonomics*, 28 (1), 27–39.
- [27] Kirwan, B., Kennedy, R., Taylor-Adams, & S., Lambert, B., (1997). The validation of three human reliability quantification techniques—THERP, HEART and JHEDI: part II- results of validation exercise. *Applied Ergonomics*, 28 (1), 17–25.
- [28] Krishnasamy, L., Khan, F.I., & Haddara, M., (2005). Development of risk-based maintenance (RBM) strategy for a power generating plant. *Journal of Loss Prevention in the Process Industries*, 18(2), 69-81.
- [29] Kumar, E.V., & Chaturvedi, S.K., (2008). Prioritization of maintenance tasks on industrial equipment for reliability. *International Journal of Quality & Reliability Management*, 28 (1), 109–126.
- [30] Lawrence, G., (2012). Cost estimating for turnarounds. *Petroleum Technology quarterly*. Q1, 37-43, [www.eqtq.com](http://www.eqtq.com).

- [31] Levitin, G., & Lisnianski, A., (2000). Optimization of imperfect preventive maintenance for multi-state system. *Reliability Engineering and System Safety*, 67 (2), 193–203.
- [32] Li, H., & Shaked, M., (2003). Imperfect repair models with preventive maintenance. *Journal of Applied Probability*, 40(4), 1043–1059.
- [33] Malik, M.A.K., (1979). Reliable preventive maintenance policy. *AIIE Transactions*, 11(3), 221–228.
- [34] Mannan, M.S., & Yang, X., (2010). The development and application of dynamic operational risk assessment in oil/gas and chemical process industry. *Reliability Engineering & System Safety*, 95 (7), 806–815.
- [35] Nakagawa, T., & Yasui, K., (1987). Optimum policies for a system with imperfect maintenance. *IEEE Transactions on Reliability*, R-36 (5), 631–633.
- [36] Nakagawa, T., Qian, C., & Zhao, X., 2012. Optimal imperfect preventive maintenance policies for a used system. *International Journal of Systems Science*, 43(9), 1632–1641.
- [37] Neil, M., & Marquez, D., (2012). Availability modeling of repairable systems using Bayesian networks. *Engineering Applications of Artificial Intelligence*, 25(4) ,698-704.
- [38] Nguyen, D.G., & Murthy, D.N.P., (1981). Optimal maintenance policy with imperfect preventive maintenance. *IEEE Transactions on Reliability*, R-30(5), 496-497.
- [39] Noroozi, A., Khakzad, N., Khan, F., MacKinnon, S., & Abbassi, R., (2013). The role of human error in risk analysis: application to pre and post-maintenance procedures of process facilities. *Reliability Engineering & System Safety*, 119, 251–258.

- [40] Noroozi, A., Khan, F., MacKinnon, S., Amyotte, P., & Deacon, T., (2014). Determination of human error probabilities in maintenance procedures of a pump. *Process Safety and Environmental Protection*, 92(2), 131–141.
- [41] Obiajunwa, C.C., (2012). A framework for the evaluation of turnaround maintenance projects. *Journal of Quality in Maintenance Engineering*, 18 (4), 368–383.
- [42] Pil, C.K., Rausand, M., & Vatn, J., (2008). Reliability assessment of reliquefaction systems on LNG carriers. *Reliability Engineering & System Safety*, 93(9), 1345–1353.
- [43] Rangan, A., & Grace, R.E., (1989). Optimal replacement policies for a deteriorating system with imperfect maintenance. *Advances in Applied Probability*, 21(4), 949–951.
- [44] Rusin, A., & Wojaczek, A., (2012). Optimization of power machines maintenance intervals taking the risk into consideration. *Eksploatacja i Niezawodnosc-Maintenance and Reliability*, 14 (1), 72–76.
- [45] Sarkar, A., & Behera, D.K., (2012). Development of risk based maintenance strategy for gas turbine power system. *International Journal of Advanced Research in Engineering and Applied Science*, 1 (2), 20–38.
- [46] Sönmez, E., Kekre, S., Scheller-Wolf, A., & Secomandi, N., (2013). Strategic analysis of technology and capacity investments in the liquefied natural gas industry. *European Journal of Operational Research*, 226 (1), 100–114.
- [47] Swain A.D., & Guttman H. E., (1983); *Handbook of Human Reliability Analysis with Emphasis on Nuclear Power Plant Applications: NUREC/CR-1278*, U.S.



- Nuclear Regulatory Commission, with Addendum #1 to NUREC/CR-1278, August 1983, September 1, 1985, by A. D. Swain.
- [48] Toriizuka, T., (2001). Application of performance shaping factor (PSF) for work improvement in industrial plant maintenance tasks. *International Journal of Industrial Ergonomics*, 28 (3-4), 225–236.
- [49] Tan, J.S., & Kramer, M.A., (1997). A general framework for preventive maintenance optimization in chemical process operations. *Computers & Chemical Engineering*, 21(12), 1451–1469.
- [50] Vatn, J., Hokstand, P., & Bodsberg, L., (1996). An overall model for maintenance optimization. *Reliability Engineering & System Safety*, 51(3), 241–257.
- [51] Vaurio, J.K., (1995). Optimization of test and maintenance intervals based on risk and cost. *Reliability Engineering and System Safety*, 49(1), 23–36.
- [52] Wang, Y., Cheng, G., Hu, H., & Wu, W., (2012). Development of a risk-based maintenance strategy using FMEA for a continuous catalytic reforming plant. *Journal of Loss Prevention in the Process Industries*, 25(6) ,958–965.
- [53] Wilson, L., & McCutcheon, D., (2003). *Industrial Safety and Risk Management*. The University of Alberta Press, Edmonton, Alberta, Canada.
- [54] Zhaoyang, T., Jianfeng, L., Zongzhi, W., Jianhu, Z., & Weifeng, H., (2011). An evaluation of maintenance strategy using risk based inspection. *Safety Science*, 49(6), 852–860.

## 7.5 References - Chapter 5

- [1] Adhikary, D.D., Bose, G.K., Jana, D.K., Bose, D., & Mitra, S., (2015). Availability and cost-centered preventive maintenance scheduling of continuous operating series systems using multi-objective genetic algorithm: A case study. *Quality Engineering*, 1-6. doi: 10.1080/08982112.2015.1086001
- [2] Ahmadi, R., & Newby, M., (2011). Maintenance scheduling of a manufacturing system subject to deterioration. *Reliability Engineering & System Safety*, 96, 1411-1420.
- [3] Ahmed, Q., Moghaddam, K. S., Raza, S. A., & Khan, F.I., (2015). A multi-constrained maintenance scheduling optimization model for a hydrocarbon processing facility. *Proceedings of the Institution of Mechanical Engineers, Part O: Journal of Risk and Reliability*, 1–18. doi. 10.1177/1748006X15573166
- [4] Amirian, H., & Sahraeian, R., (2015). Augmented  $\epsilon$ -constraint method in multi-objective flowshop problem with past sequence set-up times and a modified learning effect. *International Journal of Production Research*, 53 (19), 5962-5976.
- [5] API, (2009). *Risk Based Inspection; Recommended Practice 580; Second edition*. American Petroleum Institute, Washington, D.C., USA.
- [6] Backlund, F., & Hanu, J., (2002). Can we make maintenance decision on risk analysis?. *Journal of Quality in Maintenance Engineering*, 8 (1), 77-91.
- [7] Bertolini, M., Bevilacqua, M., Ciarapica, F.E., & Giacchetta, G., (2009). Development of Risk-Based Inspection and Maintenance procedures for an oil refinery. *Journal of Loss Prevention in the Process Industries*, 22, 244–253.

- [8] Berube, J.F., Gendreau, M., & Potvin, J.Y., (2009). An exact  $\epsilon$ -constraint method for bi-objective combinatorial optimization problems: application to the traveling salesman problem with profits. *European Journal of Operational Research*, 194, 39–50.
- [9] Campbell, J.D., Jardine, A.K.S., & McGlynn, J., (2011). *Asset Management Excellence; Optimizing Equipment Life-Cycle Decisions*; Second edition. CRC Press, Taylor & Francis Group, Boca Raton, FL, USA.
- [10] Chen, C.L., Vempati, V.S., & Aljaber, N., (1995). An application of genetic algorithms for flowshop problems. *European Journal of Operational Research*, 80, 389-396.
- [11] Coit, D.W., & Smith, A.E., (1996). Reliability optimization of series-parallel systems using a genetic algorithm. *IEEE Transactions*, 45, 254-266.
- [12] Damghani, K.K., Abtahi, A.R., & Tavana, M., (2013). A new multi-objective particle swarm optimization method for solving reliability redundancy allocation problems. *Reliability Engineering and System Safety*, 111, 58–75.
- [13] Deb, K., (2000). An efficient constraint handling method for genetic algorithms. *Computer Methods in Applied Mechanics and Engineering*, 186(2), 311-338.
- [14] Deb, K., (2001). *Multi-objective optimization using evolutionary algorithms*. Wiley-Interscience series in systems and optimization; John Wiley & Sons, Ltd., England.
- [15] Deep, K., Singh, K.P., Kansal, M.L., & Mohan, C., (2009). A real coded genetic algorithm for solving integer and mixed integer optimization problems. *Applied Mathematics and Computation*, 212 (2), 505-518.

- [16] Dowsland, K.A., (1996). Genetic algorithms-a tool for OR?. The Journal of the Operational Research Society, 47, 550-561.
- [17] Esmaeili, M., (2012). Optimize costs of the single-machine scheduling problem with maintenance activities by using genetic algorithm. Management Science Letters, 2, 673-680.
- [18] Fitouhi, M.C., & Nourelfath, M., (2014). Integrating noncyclical preventive maintenance scheduling and production planning for multi-state systems. Reliability Engineering and System Safety, 121, 175-186.
- [19] Fu, F., (2013). Maintenance scheduling optimization for electromechanical equipment based on reliability. Computer Integrated Manufacturing System, 19(12), 2940-2946.
- [20] Garg, H., Monica, R., & Sharma, S., (2013). Preventive maintenance scheduling of the pulping unit in a paper plant. Japan Journal of Industrial and Applied Mathematics, 30(2), 397-414.
- [21] Ghosh, D., & Roy, S., (2009). Maintenance optimization using probabilistic cost-benefit analysis. Journal of Loss Prevention in the Process Industry, 22, 403-407.
- [22] Go, H., Kim, J. S., & Lee, D., (2013). Operation and preventive maintenance scheduling for containerships: Mathematical model and solution algorithm. European Journal of Operational Research, 229, 626-636.
- [23] Gowid S., Dixon R., & Ghani S., (2014). Optimization of reliability and maintenance of liquefaction system on FLNG terminals using Markov modeling. International Journal of Quality & Reliability Management, 31(3), 293 – 310.

- [24] Hadi, M., Ashkan, M., & Isa, N. K. A., (2012). A reliability/availability approach to joint production and maintenance scheduling with multiple preventive maintenance services. *International Journal of Production Research*, 50, 5906-5925.
- [25] Hameed A., & Khan, F., (2014). A framework to estimate the risk-based shutdown interval for a processing plant. *Journal of Loss Prevention in the Process Industries*, 32, 18–29.
- [26] Hameed A., Khan, F. & Ahmed, S., (2014). A risk-based methodology to estimate shutdown interval considering system availability. *Process Safety Progress*, 34(3), 267-279.
- [27] Jones, D.F., Mirrazavi, S.K., & Tamiz, M., (2002). Multi-objective meta-heuristics: An overview of the current state-of-the-art. *European Journal of Operational Research*, 137 (1), 1-9.
- [28] Kancev, D., Gjorgiev, B., & Cepin, M., (2011). Optimization of test interval for ageing equipment; A multi-objective genetic algorithm approach. *Journal of Loss Prevention in the Process Industries*, 24(4), 397-404.
- [29] Kapur, K.C., & Lamberson, L.R., (1977). *Reliability in engineering design*. John Willey & Sons, Inc., Newyork, USA.
- [30] Kaveshgar, N., Huynh, N., & Rahimian, S.K., (2012). An efficient genetic algorithm for solving the quay crane scheduling problem. *Expert Systems with Applications*, 39, 13108–13117.
- [31] Keshavarz, G., Thodi, P. & Khan, F., (2011). Risk based shutdown management of LNG units. *Journal of Loss Prevention in the Process Industries*, 25(1), 159-165.

- [32] Khan F. I., & Haddara, M., (2004)<sup>a</sup>. Risk-Based Maintenance (RBM): A new approach for process plant inspection and maintenance. *American Institute of Chemical Engineers Process Safety Progress*, 23(4), 252-265.
- [33] Khan F. I., & Haddara, M., (2004)<sup>b</sup>. Risk-based maintenance of ethylene oxide production facilities. *Journal of Hazardous Materials*, A108, 147-159.
- [34] Khan F.I., & Haddara, M., (2003). Risk-based maintenance (RBM); a quantitative approach for maintenance/inspection scheduling and planning. *Journal of Loss Prevention in the Process Industries*, 16(6), 561-573.
- [35] Laumanns, M., Thiele, L., & Zitzler, E., (2006). An efficient, adaptive parameter variation scheme for metaheuristics based on the epsilon-constraint method. *European Journal of Operational Research*, 169, 932–942.
- [36] MATLAB, (2015b)<sup>a</sup>. MATLAB documentation, retrieved from <http://www.mathworks.com/help/gads/how-the-genetic-algorithm-works.html>. on Dec 14, 2015.
- [37] MATLAB, (2015b)<sup>b</sup>. MATLAB documentation, retrieved from <http://www.mathworks.com/help/gads/mixed-integer-optimization.html>. on Dec 14, 2015.
- [38] MATLAB, (2015b)<sup>c</sup>. MATLAB documentation, retrieved from <http://www.mathworks.com/help/gads/gaoptimset.html>. on Dec 14, 2015.
- [39] MATLAB, (2015b)<sup>d</sup>. MATLAB documentation, retrieved from <http://www.mathworks.com/help/gads/gaoptimset.html>. on Feb 14, 2016.
- [40] Mirabedini, S., Mina, N. H., & Iranmanesh, S.H., (2012). Multi-objective optimization research of multi parallel machine with different preventive maintenance

- planning and scheduling with genetic algorithm. *International Journal of Academic Research in Business and Social Sciences*, 2(12), 129-139.
- [41] Moghaddam, S. K., & Usher, S. J., (2011). Preventive maintenance and replacement scheduling for repairable and maintainable systems using dynamic programming. *Computers & Industrial Engineering*; 60(4), 654-665.
- [42] Mokhatab, S., Mak, J.Y., Valappil, J. V., & Wood, D. A., (2014). *Handbook of Liquefied Natural Gas*. Kidlington, Oxford, UK.
- [43] Morabi, Z.S., Owlia, M.S., Bashiri, M., & Doroudyan, M.H., (2015). Multi-objective design of  $\bar{X}$  control charts with fuzzy process parameters using the hybrid epsilon constraint. *Applied Soft Computing*, 30, 390-399.
- [44] Nwaoha, T.C., Yang, Z., Wang, J., Bonsall, S., (2010). Application of genetic algorithm to risk-based maintenance operations of liquefied natural gas carrier systems. *Proceedings of the Institution of Mechanical Engineers, Part E: Journal of Process Mechanical Engineering*, 225(1), 40-52.
- [45] Painton, L., & Campbell, J., (1995). Genetic algorithms in optimization of system reliability. *IEEE Transactions on Reliability*, 44(2), 172-178.
- [46] Rusin, A., & Wojaczek, A., (2012). Optimization of Power Machines maintenance intervals taking the risk into consideration. *Eksplotacja i Niezawodność – Maintenance and Reliability*, 14(1), 72-76.
- [47] Salvador, P.C., & Juan Carlos, R.R., (2013). A model for the preventive maintenance scheduling of power plants including wind farms. *Reliability Engineering & System Safety*, 119, 67-75.

- [48] Silver. E.A., (2004). An overview of heuristic solution methods. *Journal of the operational research society*, 55(9), 936-956.
- [49] Wang, Y., Cheng, G., Hu, H., & Wu, W., (2012). Development of a risk-based maintenance strategy using FMEA for a continuous catalytic reforming plant. *Journal of Loss Prevention in the Process Industries*, 25(6), 958-965.
- [50] Xu, B., Han X., Wang, Y., & Sun, D., (2012). Risk-based optimization model for system maintenance scheduling. *IEEE International Conference on Power System Technology (POWERCON)*, 1-6. doi: 10.1109/PowerCon.2012.6401315
- [51] Zhaoyang, T., Jianfeng, L., Zongzhi, W., Jianhu, Z., & Weifeng, H., (2011). An evaluation of maintenance strategy using risk based inspection. *Safety Science*, 49(6), 852–860.

## **7.6 References - Chapter 6**

- [1] Geem, G.W., Kim, J.H., & Loganathan, G. V., (2001). A New Heuristic Optimization Algorithm: Harmony Search. *Simulation*, 76(2), 60-68.
- [2] Glover, F., (1998). Tabu search - Wellsprings and challenges. *European Journal of Operational Research*, 106(2), 221-225.
- [3] Kirkpatrick, S., (1984). Optimization by simulated annealing: Quantitative studies. *Journal of Statistical Physics*, 34(5), 975-986.