

Serum and plasma metabolites and insemination timing associated with greater pregnancy risk in suckled beef cows subjected to artificial insemination programs

by

Scott L. Hill

B.S., Kansas State University, 1983
M.S., Kansas State University, 2013

AN ABSTRACT OF A DISSERTATION

submitted in partial fulfillment of the requirements for the degree

DOCTOR OF PHILOSOPHY

Department of Animal Sciences and Industry
College of Agriculture

KANSAS STATE UNIVERSITY
Manhattan, Kansas

2016

Abstract

Four experiments were conducted in beef cows to determine factors that increased the probability of pregnancy per AI when cows are inseminated by appointment. Cows in all experiments were inseminated after a 7-d CO-Synch + CIDR program (100 µg GnRH [2 mL Factrel, Pfizer Animal Health, Whitehouse Station, NJ] 7 d before 25 mg PGF_{2α} [d 0; 5 mL Lutalyse; Pfizer Animal Health]). Experiment 1 compared 1 vs. 2 inseminations and GnRH injection times at 60 and 75 h after the CO-Synch + CIDR program. Delaying AI until 75 h, according to interpretation of estrus-detection patches, for cows not in estrus by 60 h after CIDR insert removal increased ($P < 0.05$) pregnancy risk (PR) compared with cows not in estrus and inseminated at 60 h (51.4 vs. 41.7%), respectively. The necessity of GnRH injection concurrent with AI was tested in experiment 2. Cows displaying estrus by 65 h that were injected with GnRH had similar PR to cows in estrus and not treated with GnRH (61.9 vs. 60.4%), respectively. Cows in experiment 2 that did not display estrus, but were treated with a GnRH injection at 65 h and then inseminated at 84 h after CIDR insert removal had increased PR compared with similar cows not treated with GnRH (33.4 vs. 15.0%; $P < 0.01$), respectively. Experiments 3 and 4 were observational studies conducted to determine if blood metabolites glucose and beta-hydroxy butyrate (BHB experiment 3), or physical body and blood metabolites, (glucose, BHB, non-esterified fatty acids [NEFA], blood urea nitrogen [BUN], body weight, rump fat [RF], or BCS; experiment 4) were indicative of future reproductive success in suckled beef cows enrolled in a timed AI program. In experiment 3, plasma glucose concentration 10 d before AI was lesser ($P = 0.01$; 52.2 vs. 56.9 mg/dL) and serum BHB concentration was lesser ($P < 0.01$) in cows that became pregnant 35 d after timed AI than for cows that did not become pregnant (600 vs. 690 µM), respectively. Experiment 4 identified relationships between

indicators and reproductive success including the finding that serum NEFA concentration 2 to 4 wk before AI is negatively correlated ($P < 0.05$) with PR to AI.

Serum and plasma metabolites and insemination timing associated with greater pregnancy risk in suckled beef cows subjected to artificial insemination programs

by

Scott L. Hill

B.S., Kansas State University, 1983

M.S., Kansas State University, 2013

A DISSERTATION

submitted in partial fulfillment of the requirements for the degree

DOCTOR OF PHILOSOPHY

Department of Animal Sciences and Industry
College of Agriculture

KANSAS STATE UNIVERSITY
Manhattan, Kansas

2016

Approved by:

Major Professor
Dr. Jeffrey S. Stevenson

Abstract

Four experiments were conducted in beef cows to determine factors that increased the probability of pregnancy per AI when cows are inseminated by appointment. Cows in all experiments were inseminated after a 7-d CO-Synch + CIDR program (100 µg GnRH [2 mL Factrel, Pfizer Animal Health, Whitehouse Station, NJ] 7 d before 25 mg PGF_{2α} [d 0; 5 mL Lutalyse; Pfizer Animal Health]). Experiment 1 compared 1 vs. 2 inseminations and GnRH injection times at 60 and 75 h after the CO-Synch + CIDR program. Delaying AI until 75 h, according to interpretation of estrus-detection patches, for cows not in estrus by 60 h after CIDR insert removal increased ($P < 0.05$) pregnancy risk (PR) compared with cows not in estrus and inseminated at 60 h (51.4 vs. 41.7%), respectively. The necessity of GnRH injection concurrent with AI was tested in experiment 2. Cows displaying estrus by 65 h that were injected with GnRH had similar PR to cows in estrus and not treated with GnRH (61.9 vs. 60.4%), respectively. Cows in experiment 2 that did not display estrus, but were treated with a GnRH injection at 65 h and then inseminated at 84 h after CIDR insert removal had increased PR compared with similar cows not treated with GnRH (33.4 vs. 15.0%; $P < 0.01$), respectively. Experiments 3 and 4 were observational studies conducted to determine if blood metabolites glucose and beta-hydroxy butyrate (BHB experiment 3), or physical body and blood metabolites, (glucose, BHB, non-esterified fatty acids [NEFA], blood urea nitrogen [BUN], body weight, rump fat [RF], or BCS; experiment 4) were indicative of future reproductive success in suckled beef cows enrolled in a timed AI program. In experiment 3, plasma glucose concentration 10 d before AI was lesser ($P = 0.01$; 52.2 vs. 56.9 mg/dL) and serum BHB concentration was lesser ($P < 0.01$) in cows that became pregnant 35 d after timed AI than for cows that did not become pregnant (600 vs. 690 µM), respectively. Experiment 4 identified relationships between

indicators and reproductive success including the finding that serum NEFA concentration 2 to 4 wk before AI is negatively correlated ($P < 0.05$) with PR to AI.

Table of Contents

List of Figures	x
List of Tables	xi
Chapter 1 - Bovine Peri-estrous Period.....	1
INTRODUCTION	1
PROGESTERONE	1
OVARIAN FOLLICULAR GROWTH.....	2
ESTRUS.....	3
EXOGENOUS GnRH STIMULATION	4
UTERINE ENVIRONMENT AND SPERM CAPACITATION.....	4
INSEMINATION TIMING	5
HYPOTHESIS	7
LITERATURE CITED	8
Chapter 2 - Using estrus-detection patches to optimally time insemination improved pregnancy risk in suckled beef cows in a fixed-time artificial insemination program.....	15
INTRODUCTION	15
MATERIALS AND METHODS.....	16
Experimental Design.....	16
Treatment Assignment	16
Pregnancy Diagnosis.....	17
Cycling Status	17
Statistical Analyses	18
RESULTS	19
Pregnancy risk (PR)	19
Estrus.....	21
Cyclicity	22
DISCUSSION.....	22
LITERATURE CITED	27

Chapter 3 - GnRH increased pregnancy risk in suckled beef cows not detected in estrus and subjected to a split-time artificial insemination program	36
INTRODUCTION	36
MATERIALS AND METHODS.....	37
Experimental Design.....	37
Pregnancy Diagnosis.....	38
Estrus-Cycle Status	38
Statistical Analyses	39
RESULTS	40
Pregnancy Risk	40
Occurrence of Estrus.....	41
DISCUSSION.....	42
LITERATURE CITED	46
Chapter 4 - Indicators Related to Fertility	55
INTRODUCTION	55
HYPOTHALAMUS	55
GnRH SECRETAGOGUES.....	57
HYPOTHALAMIC NEUROPEPTIDES	60
PHYSICAL INDICATORS OF NUTRITIONAL STATUS	61
NUTRITIONAL HORMONES WITH HYPOTHALAMIC ACTIVITY.....	62
Insulin	62
Leptin	63
Insulin-like Growth Factor-1	64
SELECTED METABOLITES AND RELATED REPRODUCTIVE FUNCTION	65
β -hydroxybutyrate.....	65
Blood Urea Nitrogen.....	66
Glucose	67
Non-Esterified Fatty Acids	68
HYPOTHESIS	69
LITERATURE CITED	71
Chapter 5 - Serum and Plasma Metabolites Related to Pregnancy Risk	85

INTRODUCTION	85
MATERIALS AND METHODS.....	86
Experiment 1	86
Assays	87
Pregnancy Diagnosis.....	88
Statistical Analyses	88
Experiment 2	89
Pregnancy Diagnosis.....	91
Ovulation.....	91
Metabolite Assays	91
Statistical Analyses	91
Repeated Measures	91
Multivariate Analysis of Variance	92
RESULTS	93
Experiment 1	93
Pregnancy Risk	93
Glucose	93
Experiment 2	94
Measures Normalized to Calving.....	94
Measures Normalized to Postpartum Ovulation.....	95
Measures Normalized to Timed AI.....	95
DISCUSSION.....	97
β -hydroxybutyrate.....	97
Blood Urea Nitrogen.....	97
Glucose	99
Non-Esterified Fatty Acids	100
Physical Indicators	102
Summary.....	103
LITERATURE CITED	104

List of Figures

Figure 2.1.....	33
Figure 2.2.....	34
Figure 2.3.....	35
Figure 3.1.....	52
Figure 3.2.....	53
Figure 3.3.....	54
Figure 5.1.....	113
Figure 5.2.....	114
Figure 5.3.....	115
Figure 5.4.....	116
Figure 5.5.....	117
Figure 5.6.....	118
Figure 5.7.....	119
Figure 5.8.....	120
Figure 5.9.....	121
Figure 5.10.....	122
Figure 5.11.....	123
Figure 5.12.....	124
Figure 5.13.....	125
Figure 5.14.....	126
Figure 5.15.....	127
Figure 5.16.....	128
Figure 5.17.....	129
Figure 5.18.....	130

List of Tables

Table 2.1.	31
Table 2.2.	32
Table 3.1.	49
Table 3.2.	50
Table 3.3.	51
Table 5.1.	109
Table 5.2.	110
Table 5.3.	111
Table 5.4.	112

Chapter 1 - Bovine Periestrous Period

INTRODUCTION

The estrous cycle in cows indicates they are reproductively active. In typical beef production systems, a plurality of cows are often anestrous at the start of the breeding season and are therefore not displaying regular estrous cycles. In a natural mating system, prolonged anestrus is usually associated with delayed calving or reduced pregnancy risk (PR) in the subsequent calving season (Bellows et al., 1982). The necessity of resumption of regular estrous cycles by the first opportunity to be bred is not as essential to achieve reproductive success in a natural breeding system compared with achieving reproductive success in artificial insemination (AI) programs that utilize reproductive technologies such as fixed-time AI at the start of a breeding season. Reproductive management strategies that initiate and synchronize estrus or ovulation can decrease the calving interval, increase the calf crop, and more uniformly group cows for a shorter calving season.

PROGESTERONE

The naturally estrus-cycling cow after her second postpartum ovulation will have circulating progesterone concentrations greater than 1 ng/mL before the luteal phase is terminated by luteolysis (Perry et al., 1991). Postpartum cows are considered to have a short estrous cycle (short inter-ovulatory period) when progesterone concentrations > 1 ng/mL for less than 7 d (Werth et al., 1996). Cows that have a shorter than normal luteal phase after calving are characterized as having fewer progesterone receptors in their uterus (Zollers et al., 1993), fewer pregnancies per AI (Werth et al., 1996; Perry et al., 1991), but similar ovulatory follicle size (Perry et al., 1991) compared with cows with normal luteal phases.

Estrus- or ovulation-synchronization programs that include an intravaginal progestin insert eliminate the reduction in PR associated with short cycles (Stevenson et al., 2000, 2003). Pregnancy risk of primiparous, but not multiparous, beef cows exposed to a timed AI (TAI) program is increased when progesterone concentrations > 1 ng/mL at the beginning of the programs (Stevenson et al., 2015). In contrast, dairy cows with greater concentration of progesterone at the initiation of a TAI system are reported to have greater PR than cows with lesser progesterone (Stevenson and Lamb, 2016). Diameter of the preovulatory dominant follicle is associated with the size of the subsequent corpus luteum, concentration of progesterone, and PR (Dadarwal et al., 2013).

OVARIAN FOLLICULAR GROWTH

Reduced PR and increased embryonic mortality in suckled beef cows are associated with pre-ovulatory follicles ≤ 11 mm near the time of ovulation (Perry et al., 2005). Larger follicles are associated with greater serum concentrations of estradiol than smaller follicles at the time of AI in TAI programs (Atkins et al., 2010b). Improvements in reproductive performance associated with large follicles are likely related to the increased estradiol secretion associated with large follicles (Geary et al., 2013). Furthermore, growth rate of dominant follicles is dependent on their acquisition of LH receptors as well as the systemic concentrations of progesterone during their growth (Dadarwal et al., 2013). Follicles that have a greater rate of growth result in preovulatory follicles of a greater size at ovulation than slower growing follicles (Atkins et al., 2010a). The day of estrous cycle and the estrus-cycle status of cows at the initiation of the TAI program affect the size of the preovulatory follicle at the time of induced ovulation concurrent with insemination.

ESTRUS

Estrus expression is the most obvious visual indicator of stage of cycle status in cattle. Numerous studies have documented that cows displaying estrus at or near the time of AI have greater PR to TAI than cows not displaying estrus (Perry et al., 2005; Busch et al., 2008; Hill et al., 2014; Richardson et al., 2016). Perry et al. (2005) also reported that cows exhibiting estrus had greater concentrations of circulating estradiol and greater subsequent concentrations of progesterone than anestrous cows. Increasing the number of beef cows in estrus at the same time also increased the number of times a cow was mounted and the duration of estrus (Floyd et al., 2009), and may increase the possibility of identifying more cows with less overt estrus expression in order to inseminate them at a more proper time in a split-time AI program (a program in which cows are inseminated at one of two predetermined times according to the expression of estrus at or before the first time).

Increased proportion of cows displaying estrus and becoming pregnant also is associated with greater conceptus size at d 19 of pregnancy and greater abundance of transcriptions for proteins in the endometrium that are favorable to pregnancy establishment and maintenance (Davoodi et al., 2015). Heifers inseminated after expressing estrus also had better quality embryos at a more advanced physiological stage than heifers not expressing estrus (Larimore et al., 2015). Acidification of the uterus (pH 7.0 to 6.7) occurs in cows that express estrus (Perry and Perry, 2008 a, b) and prolonged viability of sperm has been associated with decreased intracellular sperm pH (Jones and Bavister, 2000). It is clear that the uterine environment and endocrine milieu is more suitable for fertilization and embryo development in cows that express estrus compared with those not in estrus. Recent research in beef cattle induced to ovulate immature smaller follicles indicated that deficient uterine function is a major factor responsible

for infertility in these cows (Bridges et al., 2013). Failure to produce adequate concentrations of estradiol before ovulation results in delayed expression of uterine genes and proteins that participate in regulating uterine functions during early gestation (Bridges et al., 2013).

EXOGENOUS GnRH STIMULATION

Timed AI programs depend on ovulation occurring, either induced or spontaneous, within the time frame of uterine and oviductal sperm viability. Early TAI studies demonstrated that GnRH injection concurrent with AI or 24 h before AI resulted in similar PR (Geary et al., 1998). The surge in LH release from the anterior pituitary may be augmented by administering GnRH before ovulation; however, circulating concentrations of LH are only minimally influenced by exogenous GnRH after ovulation in dairy cows (Lucy and Stevenson, 1986; Pulley et al., 2015). In another experiment conducted in beef cows that displayed estrus, no increase was detected in the proportion of cows becoming pregnant after AI when GnRH was administered at the time of AI (Perry and Perry, 2009). In that study, cows were subjected to AI between 6 and 18 h after estrus was first detected. The interval from initiation of estrus until AI in a TAI program can be quite variable, which may limit the effectiveness of a GnRH injection administered concurrently with AI.

UTERINE ENVIRONMENT AND SPERM CAPACITATION

The uterus in the peri-estrous period undergoes changes that facilitate the opportunities for fertilization of the newly ovulated ovum or ova. The cervix is the primary gatekeeper of the uterus that allows sperm transport after natural service during estrus but prevents uterine contamination during the remainder of the cycle or during pregnancy. Changes in cervical histology are evident during estrus. Cervices of heifers at various stages of the estrous cycle were examined in a study to determine changes at the time of estrus (Pluta et al., 2011). Sulfated

mucins were more abundant, epithelial height was greater, and both neutral and acid mucins differed in concentration in heifers that were in estrus compared with heifers in other stages of the cycle. In a follow up study, Pluta et al. (2012) reported that the physical changes detected at estrus were related to transcriptional changes in the cervical tissue.

Capacitation of sperm is necessary before fertilization can occur (Hunter and Rodríguez-Martínez, 2004). The process of capacitation may take from 5 to 10 h depending on sperm location in the female tract. Recognizing the importance of capacitation timing is foundational to classical work reported by Saacke (2008) that illustrates the importance of insemination timing relative to the onset of estrus. In those studies, cows inseminated near the onset of estrus tended to have lesser fertilization risk but greater embryonic quality compared with cows inseminated at 24 h after the onset of estrus, in which fertilization risk was greater but embryo quality was compromised. Therefore, Saacke (2008) conclude that inseminating cows according the traditional a.m.-p.m. rule is a compromise of achieving maximal fertilization success and maintaining embryo quality compared with inseminating very early or very late relative to the onset of estrus.

INSEMINATION TIMING

Fixed-time AI is a strategy to reduce the variation in the timing of ovulation among females to maximize fertility after a single AI at a predetermined time. Reproductive strategies that employ PGF_{2α}, GnRH, and progestins have reduced the variation in timing of estrus after PGF_{2α} in populations of cows subjected to AI. Although ovulation after estrus is reported to be 31 ± 0.6 h in beef cows (White et al., 2002), the variation in timing of ovulation after PGF_{2α} in beef cows exposed to a TAI system has not been quantified. A study that examined the time differential from display of estrus to ovulation in primiparous dairy cows, the researchers

reported a 12- to 16-h interval from the onset of estrus to maximum PR associated with AI (Stevenson et al., 2014). Ovulation control programs are designed to maximize the opportunity for viable sperm and ova to interact in the oviduct after AI in beef cows.

In AI systems that allow all cows to be inseminated at a predetermined time, the demand for time conformity of insemination may supersede optimal timing of semen placement relative to estrus or ovulation. Several different strategies have been employed to minimize the difference between actual and optimal timing of AI by examining various single-insemination timings to produce the greatest probability of conception (Busch et al., 2008, Dobbins et al., 2009, Wilson et al., 2010). Allocating cows to optimal fixed times utilizing specific criteria, except for varying the time of AI for all cows (Dobbins et al., 2009) is largely unexplored. Although distribution of ovulation has not been quantified in TAI systems, hours to estrus following PGF_{2α} treatments concurrent with progesterone withdrawal has been investigated after employing the CO-Synch + CIDR (GnRH injected 7 d before and at 60 to 66 h after PGF_{2α} with an intravaginal progesterone-impregnated insert [CIDR] applied for 7 d starting with the first GnRH injection) program (Busch et al., 2008; Geary et al., 2000; Wilson et al., 2010). Previous studies have identified conditions that alter the proportion of cows that display estrus at a given time or in total. Postpartum suckled cows that are anestrous at the onset of TAI programs seem to display estrus earlier than their estrus-cycling herd mates (Geary et al., 2000; Stevenson et al., 2000; Busch et al., 2008). Cows with a lesser BCS, however, are less likely to display estrus than cows with a greater BCS (Richardson et al., 2016). Stage of the estrous cycle at the initiation of a synchronization program for estrus-cycling heifers can alter the timing of estrus (Atkins et al., 2008). The reported distribution of estrus (36 through 120 h after CIDR insert removal), in addition to differences in identifiable groups based on parity, day of cycle, and estrus-cycle

status, indicates that more than 1 insemination time may increase pregnancy risk (PR) associated with TAI particularly in groups of cows composed of both anestrous and cycling cows. A study that administered AI at 58 or 76 h reported that cows displaying estrus had greater PR than cows that were not identified in estrus at either time (Markwood et al., 2014). In a study utilizing sex-sorted semen, increases in PR were noted when utilizing 2 AI times separated by a 20 h interval (Thomas et al., 2014a). In another study examining 2 AI times with conventional semen, no difference in PR was detected between early and later-inseminated non-estrous cows (Thomas et al., 2014b). The timing chosen for the Thomas studies (66 and 86 h) may not be designed to minimize the differential between actual and optimal insemination timings.

HYPOTHESIS

The time period when fertile gametes are present together in the oviduct to achieve maximal fertilization in a TAI program may be increased when more than one insemination time is employed. We hypothesize that inseminating cows at two different times based on expression of estrus will 1) increase PR per AI, and 2) reduce the necessity for a GnRH-induced ovulation in cows that have already expressed estrus before TAI.

LITERATURE CITED

- Atkins, J. A., D. C. Busch, J. F. Bader, D. H. Keisler, D. J. Patterson, M. C. Lucy, and M. F. Smith. 2008. Gonadotropin-releasing hormone-induced ovulation and luteinizing hormone release in beef heifers: Effect of day of the cycle. *J. Anim. Sci.* 86:83–93. doi: 10.2527/jas.2007-0277.
- Atkins, J. A., M. F. Smith, K. J. Wells, and T. W. Geary. 2010a. Factors affecting preovulatory follicle diameter and ovulation rate after gonadotropin-releasing hormone in postpartum beef cows. Part I: Cycling cows. *J. Anim. Sci.* 88:2300–2310. doi:10.2527/jas.2009-2531.
- Atkins, J. A., M. F. Smith, K. J. Wells, and T. W. Geary. 2010b. Factors affecting preovulatory follicle diameter and ovulation rate after gonadotropin-releasing hormone in postpartum beef cows. Part II: Anestrous cows. *J. Anim. Sci.* 88:2311–2320. doi:10.2527/jas.2009-2532.
- Bellows, R. A., R. E. Short, and G. V. Richardson. 1982. Effects of sire, age of dam and gestation feed level on dystocia and postpartum reproduction. *J. Anim. Sci.* 55:18–27.
- Bridges, G. A., M. L. Day, T. W. Geary, and L. H. Cruppe. 2013. Deficiencies in the uterine environment and failure to support embryonic development. *J. Anim. Sci.* 91:3002-3013. doi: 10.2527/jas.2013-5882.
- Busch, D. C., D. J. Schafer, D. J. Wilson, D. A. Mallory, N. R. Leitman, J. K. Haden, M. R. Eppers, M. F. Smith, and D. J. Patterson. 2008. Timing of artificial insemination in postpartum beef cows following administration of the CO-Synch + controlled internal drug release protocol. *J. Anim. Sci.* 86:1519–1525. doi: 10.2527/jas.2008-0925.

- Dadarwal, D., R. J. Mapletoft, G. P. Adams, L. F. Pfeifer, C. Creelman, and J. Singh. 2013. Effect of progesterone concentration and duration of proestrus on fertility in beef cattle after fixed-time artificial insemination. *Theriogenology* 79:859–866. doi: 10.1016/j.theriogenology.2013.01.003.
- Davoodi, S., R. F. Cooke, A. C. C. Fernandes, B. I. Cappellozza, J. L. M. Vasconcelos, and R. L. A. Cerri. 2015. Expression of estrus modifies the gene expression profile in reproductive tissues on day 19 of gestation in beef cows. *Theriogenology in press*:1–11. doi: 10.1016/j.theriogenology.2015.10.002.
- Dobbins, C. A., D. R. Eborn, D. E. Tenhouse, R. M. Breiner, S. K. Johnson, T. T. Marston, and J. S. Stevenson. 2009. Insemination timing affects pregnancy rates in beef cows treated with CO-Synch protocol including an intravaginal progesterone insert. *Theriogenology* 72:1009–1016. doi: 10.1016/j.theriogenology.2009.06.025.
- Floyd, L. N., C. A. Lents, F. J. White, and R. P. Wettemann. 2009. Effect of number of cows in estrus and confinement area on estrous behavior of beef cows. *J. Anim. Sci.* 87:1998–2004. doi: 10.2527/jas.2008-1380.
- Geary, T. W., E. R. Downing, J. E. Bruemmer, and J. C. Whittier. 2000. Ovarian and estrous response of suckled beef cows to the Select Synch estrous synchronization protocol. *Prof. Anim. Sci.* 16:1–5.
- Geary, T. W., M. F. Smith, M. D. MacNeil, M. L. Day, G. A. Bridges, G. A. Perry, F. M. Abreu, J. A. Atkins, K. G. Pohler, E. M. Jinks, and C. A. Madsen. 2013. Triennial reproduction symposium: Influence of follicular characteristics at ovulation on early embryonic survival. *J. Anim. Sci.* 91:3014–3021. doi: 10.2527/jas.2012-5887.

- Geary, T. W., and J. C. Whittier. 1998. Effects of a timed insemination following synchronization of ovulation using the Ovsynch or CO-Synch protocol in beef cows. *Prof. Anim. Sci.* 14:217–220.
- Hill, S. L., G. A. Perry, V. R. Mercadante, G. C. Lamb, J. R. Jaeger, KC Olson, and J. S. Stevenson. 2014. Altered progesterone concentrations by hormonal manipulations before a fixed-time artificial insemination CO-Synch + CIDR program in suckled beef cows. *Theriogenology* 82:104–13. doi: 10.1016/j.theriogenology.2014.03.008.
- Hunter, R. H., and H. Rodríguez-Martínez. 2004. Capacitation of mammalian spermatozoa in vivo, with a specific focus on events in the fallopian tubes. *Mol. Reprod. Dev.* 67:243–250. doi: 10.1002/mrd.10390.
- Jones, J. M., and B. D. Bavister. 2000. Acidification of intracellular pH in bovine spermatozoa suppresses motility and extends viable life. *J. Androl.* 21:616–624.
- Larimore, E. L., O. L. Amundson, S. L. Bird, B. J. Funnell, S. G. Kruse, G. A. Bridges, and G. A. Perry. 2015. Influence of estrus at fixed-time artificial insemination on early embryonic development in beef cattle. *J. Anim. Sci.* 93:2806–2812. doi: 10.2527/jas.2015-8892.
- Lucy, M.C., and J.S. Stevenson. 1986. Gonadotropin-releasing hormone at estrus: Luteinizing hormone, estradiol, and progesterone during the periestrual and postinsemination periods in dairy cattle. *Biol. Reprod.* 35:300–311.
- Markwood, M. G., R.K. Peel, J. K. Ahola, G. E. Seidel Jr., R. N. Funston, S. L. Lake, and J. C. Whittier. 2014. Effect of delaying time AI based on Estroject patch status on pregnancy rates of nursing beef cows. *Proc. West. Sect. Anim. Soc.* 65:79-82.

- Perry, G. A., and B. L. Perry. 2008a. Effect of preovulatory concentrations of estradiol and initiation of standing estrus on uterine pH in beef cows. *Domest. Anim. Endocrinol.* 34:333–338.
- Perry, G. A., and B. L. Perry. 2008b. Effects of standing estrus and supplemental estradiol on changes in uterine pH during a fixed-time artificial insemination protocol. *J. Anim. Sci.* 86:2928–2935. doi: 10.2527/jas.2008-1181.
- Perry, G. A., and B. L. Perry. 2009. GnRH treatment at artificial insemination in beef cattle fails to increase plasma progesterone concentrations or pregnancy rates. *Theriogenology* 71:775–779. doi:10.1016/j.theriogenology.2008.09.050.
- Perry, R. C., L. R. Corah, G. H. Kiracofe, J. S. Stevenson, and W. E. Beal. 1991. Endocrine changes and ultrasonography of ovaries in suckled beef cows during resumption of postpartum estrous cycles. *J. Anim. Sci.* 69:2548–2555.
- Perry, G. A., M. F. Smith, M. C. Lucy, J. A. Green, T. E. Parks, M. D. MacNeil, A. J. Roberts, and T. W. Geary. 2005. Relationship between follicle size at insemination and pregnancy success. *Proc. Natl. Acad. Sci. USA* 102:5268–5273.
- Perry, R. C., L. R. Corah, G. H. Kiracofe, J. S. Stevenson, and W. E. Beal. 1991. Endocrine changes and ultrasonography of ovaries in suckled beef cows during resumption of postpartum estrous cycles. *J. Anim. Sci.* 69:2548–2555.
- Pluta, K., J. A. Irwin, C. Dolphin, L. Richardson, E. Fitzpatrick, M. E. Gallagher, C. J. Reid, M. A. Crowe, J. F. Roche, P. Lonergan, S. D. Carrington, and A. C. Evans. 2011. Glycoproteins and glycosidases of the cervix during the peri-estrous period in cattle. *J. Anim. Sci.* 89:4032–4042. doi: 10.2527/jas.2011-4187.

- Pluta, K., P. A. McGettigan, C. J. Reid, J. A. Browne, J. A. Irwin, T. Tharmalingam, A. Corfield, A. Baird, B. J. Loftus, A. C. Evans, and S. D. Carrington. 2012. Molecular aspects of mucin biosynthesis and mucus formation in the bovine cervix during the peri-estrous period. *Physiol. Genomics*. 44:1165-1178. doi: 10.1152/physiolgenomics.00088.2012.
- Pulley, S. L., D. H. Keisler, and J. S. Stevenson. 2015. Concentrations of luteinizing hormone and ovulatory responses in dairy cows before timed artificial insemination. *J. Dairy Sci.* 98:6188–6201. doi:10.3168/jds.2015-9473.
- Richardson, B. N., S. L. Hill, J. S. Stevenson, G. D. Gemechis, and G. A. Perry. 2016. Expression of estrus before fixed-time AI affects conception rates and factors that impact expression of estrus and the repeatability of expression of estrus in sequential breeding seasons. *Anim. Reprod. Sci.* 166:133–140. doi:10.1016/j.anireprosci.2016.01.013.
- Saacke, R. G. 2008. Insemination factors related to timed AI in cattle. *Theriogenology* 70:479–484.
- Stevenson, J. S., S. L. Hill, G. A. Bridges, J. E. Larson, and G. C. Lamb. 2015. Progesterone status, parity, body condition, and days postpartum before estrus or ovulation synchronization in suckled beef cattle influence artificial insemination pregnancy outcomes. *J. Anim. Sci.* 93:2111–2123. doi: 10.2527/jas.2014-8391.
- Stevenson, J. S., S. L. Hill, R. L. Nebel, and J. M. DeJarnette. 2014. Ovulation timing and conception risk after automated activity monitoring in lactating dairy cows. *J. Dairy Sci.* 97:4296–4308. doi: 10.3168/jds.2013-7873.
- Stevenson, J. S., and G. C. Lamb. 2016. Contrasting effects of progesterone on fertility of dairy and beef cows. *J. Dairy Sci.* doi: S0022-0302(16)00114-4.

- Stevenson, J. S., G. C. Lamb, S. K. Johnson, M. A. Medina-Britos, D. M. Grieger, K. R. Harmony, J. A. Cartmill, S. Z. El-Zarkouny, C. R. Dahlen, and T. J. Marple. 2003. Supplemental norgestomet, progesterone, or melengestrol acetate increases pregnancy rates in suckled beef cows after timed inseminations. *J. Anim. Sci.* 81:571–586.
- Stevenson, J. S., K. E. Thompson, W. L. Forbes, G. C. Lamb, D. G. Grieger, and L. R. Corah. 2000. Synchronizing estrus and (or) ovulation in beef cows after combinations of GnRH, norgestomet, and prostaglandin F_{2α} with or without timed insemination. *J. Anim. Sci.* 78:1747–1758. doi:/2000.7871747x.
- Thomas, J. M., S. L. Lock, S. E. Poock, M. R. Ellersieck, M. F. Smith, and D. J. Patterson. 2014a. Delayed insemination of nonestrous cows improves pregnancy rates when using sex-sorted semen in timed artificial insemination of suckled beef cows. *J. Anim. Sci.* 92:1747–1752. doi: 10.2527/jas.2013–7131.
- Thomas, J. M., S. E. Poock, M. R. Ellersieck, M. F. Smith, and D. J. Patterson. 2014b. Delayed insemination on non-estrous heifers and cows when using conventional semen in artificial insemination. *J. Anim. Sci.* 92:4189–4197. doi: 10.2527/jas.2014-7827.
- Werth, L. A., J. C. Whittier, S. M. Azzam, G. H. Deutscher, and J. E. Kinder. 1996. Relationship between circulating progesterone and conception at the first postpartum estrus in young primiparous beef cows. *J. Anim. Sci.* 74:616–619.
- White, F. J., R. P. Wettemann, M. L. Looper, T. M. Prado, and G. L. Morgan. 2002. Seasonal effects on estrous behavior and time of ovulation in nonlactating beef cows. *J. Anim. Sci.* 80:3053–3059.
- Wilson, D. J., D. A. Mallory, D. C. Busch, N. R. Leitman, J. K. Haden, D. J. Schafer, M. R. Ellersieck, M. F. Smith, and D. J. Patterson. 2010. Comparison of short-term progestin-

based protocols to synchronize estrus and ovulation in postpartum beef cows. *J. Anim. Sci.* 88:2045–2054. doi: 10.2527/jas.2009-2627.

Zollers, Jr., W. G., H. A. Garverick, M. F. Smith, R. J. Moffatt, B. E. Salfen, and R. S. Youngquist. 1993. Concentrations of progesterone and oxytocin receptors in endometrium of postpartum cows expected to have a short or normal oestrous cycle. *J. Reprod. Fertil.* 97:329–337.

Chapter 2 - Using estrus-detection patches to optimally time insemination improved pregnancy risk in suckled beef cows in a fixed-time artificial insemination program

INTRODUCTION

Ovulation control programs are designed to maximize the opportunity for viable sperm and ova to interact in the oviduct after AI in beef cows. In AI systems that allow all cows to be inseminated at a predetermined time (fixed-time AI or TAI), the demand for time conformity of insemination may supersede optimal timing of semen placement relative to estrus or ovulation. Several different strategies have been employed to minimize the difference between actual and optimal timing by examining various single-insemination timings to produce the greatest probability of conception (Busch et al., 2008, Dobbins et al., 2009, Wilson et al., 2010). Allocating cows to optimal fixed times utilizing specific criteria, except for varying the time of AI for all cows (Dobbins et al., 2009), is largely unexplored. Although variation in the timing of ovulation has not been quantified in TAI systems, hours to estrus following PGF_{2α} treatments concurrent with progesterone withdrawal has been investigated in the CO-Synch + CIDR program (Busch et al., 2008, Wilson et al., 2010). The reported distribution of estrus (36 through 120 h after CIDR insert removal), in addition to differences in identifiable groups based on parity and cyclicity, indicates that multiple insemination times may increase pregnancy risk (PR) associated with TAI particularly in heterogeneous groups of cows. The objective of this study was to test the hypothesis that allocating cows into 2 distinct insemination times based on activated estrus-detection patches would increase PR.

MATERIALS AND METHODS

All experimental procedures were approved by the respective Animal Care and Use Committees of the institutions participating in the study.

Experimental Design

A total of 1,611 mixed parity beef cows at 15 locations in 9 states (CO, IL, KS, MN, MS, MT, ND, SD, and VA) were enrolled in the experiment. Characteristics of suckled beef cows enrolled by location including breed, percentage of 2-year-old cows, days postpartum at AI, BCS, and proportion of cows having estrous cycles at the onset of the synchronization program were summarized (Table 2.1). All cows were treated with a 7-d CO-Synch + CIDR program (100 µg GnRH [2 mL Factrel, Pfizer Animal Health, Whitehouse Station, NJ] 7 d before and 60 or 75 h after 25 mg PGF_{2α} [d 0; 5 mL Lutalyse; Pfizer Animal Health]). A controlled internal drug release (CIDR) insert (Pfizer Animal Health) containing 1.38 g progesterone was inserted per vagina at the time of the first GnRH injection (d -7). On d 0, concurrent with CIDR insert removal, estrus-detection patches (Estroprotect, Rockway, Inc., Spring Valley, WI) were affixed to the tail head of each cow according to manufacturer's recommendation. Body condition scores (1 = thin; 9 = very fat; Bellows et al., 1982) were assigned (d -17) before the start of the ovulation synchronization program by a trained evaluator (Figure 2.1).

Treatment Assignment

Estrus-detection patches were interpreted and treatment assignments were made at 60 h after CIDR insert removal. Cows were defined to have exhibited estrus (evidence of standing activity) when > 50% of the gray coating was rubbed off or when the patch was missing (< 10% were missing patches). Cows in estrus by 60 h had patches removed, received an injection of 100 µg GnRH, and were inseminated (Control). Cows that had not exhibited estrus by 60 h were

balanced according to days postpartum and parity and assigned randomly to 3 treatments: 1) injected with 100 µg GnRH and inseminated at 60 h (early-early; EE); 2) injected with 100 µg GnRH at 60 h but inseminated at 75 h (early-delayed; ED); or 3) injected with 100 µg GnRH and inseminated at 75 h (delayed-delayed; DD). At 75 h, all patches were evaluated and removed from EE, ED, and DD cows to determine if estrus had occurred between 60 and 75 h (Figure 2.1).

Pregnancy Diagnosis

Cows were either observed for heat and inseminated on subsequent estrus or exposed to cleanup bulls beginning 10 to 12 d after TAI. At 35 ± 3 d after TAI, pregnancy was confirmed by transrectal ultrasonography (Aloka 500V, 5 MHz transrectal transducer, Wallingford, CT). A positive pregnancy outcome required presence of a corpus luteum and uterine fluid or an embryo with a heartbeat. A final pregnancy diagnosis was determined via transrectal ultrasonography approximately 35 d after the end of the breeding season (removal of natural service sires).

Cycling Status

Blood samples were collected via puncture of the caudal blood vessel from cows at 10 of the 14 locations on d -17 and -7 . Concentrations of progesterone in serum were measured in all blood samples by direct quantitative (non-extracted) RIA using Coat-A-Count progesterone kits (Siemens Medical Solutions Diagnostics, Los Angeles, CA) previously validated for bovine serum (Stevenson et al., 2012). Intra- and inter-assay CV for progesterone was 8.9 and 6.1%, respectively. Assay sensitivity was 14.1 ± 1.6 pg/mL. Progesterone concentrations were categorized as high (≥ 1 ng/ml) or low (all other samples). Cows with a high progesterone status at either d -17 or -7 were defined to have resumed estrous cycles (Table 2.1). All other cows were considered to have been anestrous at the onset of the ovulation synchronization program.

Statistical Analyses

The GLIMMIX procedure (method = laplace; ilink = logit dist = binomial solution oddsratio) in SAS (SAS Inst. Inc., Cary, NC) was applied to analyze the binomial outcome variables of cyclicity, estrus expression, and PR associated with AI. The independent variables of BCS, days postpartum, and parity (primiparous vs. multiparous) were included as fixed effects in all models. The median value of BCS (BCS = 5.0) was used to allocate cows into 2 BCS categories (< 5.0 vs. \geq 5.0). Treatment was tested as a fixed effect in the model that examined PR. Significance of treatment was tested by the random effect of treatment within location. Models included interactions of treatment with the fixed effects of parity, BCS, and the continuous variable days postpartum. When no significant interactions with treatment were detected, interactions with treatment were eliminated from the final model. The 2- and 3-way interactions among the variables days postpartum, BCS, and parity were then included in the model. Because a 3-way interaction was detected among parity, BCS, and days postpartum, days postpartum was grouped into quartiles and tested for interactions. Pregnancy risk changed when days postpartum were proportioned at 86 d resulting in identification of the interaction. A separate model including total expression of estrus (excluded treatment), examined 2-, 3-, and 4-way interactions with BCS, days postpartum, parity, and estrus expression on the dependent variable of PR. No interactions with estrus expression were identified and were therefore removed from the model.

Models to examine expression of estrus were constructed for cows that exhibited estrus by 60 h, between 60 and 75 h, and by 75 h. The general models for estrus at each of the 3 times included cyclicity, BCS, and parity. The continuous variable, days postpartum, was converted to a binomial variable by dividing the range of days postpartum at its median (< 75 vs. \geq 75 d).

Effects of cyclicity were not significant when evaluated in any of the 3 models; therefore, cyclicity was eliminated to include cows for which cycling information was not available. The 2- and 3-way interactions of days postpartum, BCS, and parity were included in all estrous models. The effect of GnRH injection timing was evaluated in a model that included estrus expression between 60 and 75 h as the dependent variable; GnRH injection time of 60 or 75 h was treated as an independent fixed variable to determine the effect of prior GnRH exposure on subsequent expression of estrus. The GnRH timing model also included BCS, days postpartum, and parity as fixed effects. The random variable location was included as the testing term in all estrous models.

The subset of cows for which cycling information existed was analyzed in a separate GLIMMIX model with cyclicity as the dependent variable. The independent fixed variables; BCS, parity, and days postpartum, all 2- and 3-way interactions among those variables, and the random effect of location were included in the model.

Final pregnancy risk and pregnancy loss (pregnancy loss between TAI and the final pregnancy diagnosis at the end of the breeding season) were both analyzed in models containing treatment or estrus expression and BCS, parity and days postpartum. In all models, differences were determined to be significant when $P < 0.05$.

RESULTS

Pregnancy risk (PR)

Control cows (HT) had a greater ($P < 0.01$) PR than cows in the EE, ED, or DD treatments (Figure 2.2). Pregnancy risk for cows in which AI was performed at 75 h (ED and DD) did not differ ($P = 0.50$) between treatments, however PR was greater ($P < 0.05$) than for EE cows. The poorest PR was detected in EE cows (not detected in estrus but inseminated and

treated with GnRH at 60 h). Cows not detected in estrus by 60 h, but expressed estrus by 75 h (49.2% of cows not observed in estrus by 60 h) were more ($P < 0.05$) likely to become pregnant than non-estrous herd mates when they were in the EE (46.1 vs. 34.5%), ED (64.2 vs. 39.2%), and DD (64.8 vs. 31.5%) treatments, respectively. When assessing PR, no 2- and 3-way interactions were detected among treatments, BCS, and parity.

Final PR did not differ among treatments, parity, or days postpartum; however cows with a $BCS \leq 5$ had lesser ($P < 0.01$) PR than cows with a $BCS > 5$ (94.1 vs. 89.5%, respectively). Final PR also was greater ($P = 0.001$) in cows that displayed estrus at either 60 or 75 h than those that did not display estrus (94.0 vs. 89.3%), respectively. The pregnancy loss (cows pregnant after TAI but not at the end of the breeding season) was $1.3 \pm 0.4\%$. Pregnancy loss did not differ between parity, estrus expression, days postpartum, or BCS. The pregnancy losses associated with treatments (Control, DD, ED, and EE) were 1.0, 0.2, 2.1, and 0.4%, respectively. Pregnancy loss was greater ($P = 0.04$) in ED than DD.

Days postpartum at TAI was analyzed as a covariate in the model describing the effects of treatment on PR. Days postpartum were related positively ($P < 0.001$) with the PR at 35 d post breeding, indicating that for every 10-d increase in days postpartum at AI, PR increased by $7.2 \pm 1.6\%$. Pregnancy risk was not affected ($P = 0.30$) by BCS. In contrast, PR in multiparous cows was 1.43 times (AOR = 1.43; CI = 1.03 to 1.98) more likely than in primiparous cows (56.7 vs. 47.8%). Cows that had resumed cyclicity before the onset of the breeding season were 1.72 times (AOR = 1.72; CI = 1.29 to 2.29) more likely to become pregnant to AI than their anestrous herd mates (60.9 vs. 47.5%). Furthermore, cows detected in estrus by 75 h were 2.6 times (AOR = 2.60; CI = 1.95 to 3.46) more likely to become pregnant to AI than their herd mates that did not exhibit estrus (61.3 vs. 37.9%).

Effects of the independent variables, days postpartum, parity, and BCS on PR were analyzed separately and a 3-way interaction was detected ($P = 0.05$; Figure 2.3). Pregnancy risk was compromised in primiparous cows with poorer BCS and fewer days postpartum at AI compared with all other variable combinations of days postpartum, BCS, and parity.

Estrus

A summary of when estrus was expressed (by 60 h or between 60 and 75 h) and the effects of BCS, parity, and days postpartum on expressed estrus are in Table 2.2. Overall, 46.3% of cows showed estrus by 60 h, 49.2% of the remaining cows showed estrus between 60 and 75 h, and 27.3% were not detected in estrus by 75 h after CIDR insert removal.

Although days postpartum did not affect the expression of estrus, primiparous, better conditioned cows were more likely to display estrus by 60 h than any other combination of parity and BCS (Table 2.2).

An interaction between parity and BCS was not detected in cows that displayed estrus between 60 and 75 h (Table 2). Neither days postpartum nor parity influenced expression of estrus during this 15-h interval; however, there were more of the better-conditioned cows showing estrus than those carrying less body condition (Table 2.2).

When estrus was expressed by 75 h; however, more primiparous cows with $BCS > 5$ were detected in estrus compared with all other combinations of parity and BCS (Table 2.2). Cows with more than 75 d since calving at AI did not differ ($P > 0.49$) from their herd mates with shorter postpartum intervals in expression of estrus by 75 h (Table 2.2).

When comparing occurrence of estrus between 60 and 75 h in the EE and ED cows, which received GnRH at 60 h, expression of estrus was not reduced ($P = 0.21$) subsequent to GnRH compared with the DD cows that received GnRH at 75 h (44.9 vs. 49.5%), respectively.

Cyclicity

In a subset of cows ($n = 1,046$) factors affecting cyclicity at the beginning of the breeding season were analyzed. When all 2-way interactions among BCS, days postpartum, and parity were tested, an interaction of magnitude was detected between BCS and days postpartum. The combination of > 75 d postpartum and $BCS > 5$ resulted in greater ($P < 0.006$) cyclicity (78.2%) than the combinations of days > 75 and $BCS \leq 5$ (59.6%), days ≤ 75 d and $BCS > 5$ (48.4%), or days ≤ 75 d and $BCS \leq 5$ (54.9%), respectively. The proportion of primiparous and multiparous cows having resumed estrous cycles before AI did not differ ($P = 0.37$; 64.4 vs. 57.7%), respectively.

DISCUSSION

Fixed-time AI is a strategy to reduce the variation in the timing of ovulation among females to maximize fertility after a single AI. Reproductive strategies that employ $PGF_{2\alpha}$, GnRH, and progestins have reduced the distribution of estrus in populations of cows subjected to AI. Ovulation after estrus is reported to be 31 ± 0.6 h in beef cows (White et al., 2002). The distribution of ovulation in beef cows exposed to a TAI system has not been quantified; however numerous studies have shown increased proportion of cows becoming pregnant after TAI when they exhibit estrus at or before time of GnRH to induce ovulation (Perry et al., 2005; Busch et al., 2008; Hill et al., 2014). Perry et al. (2005) also found that cows exhibiting estrus had greater concentrations of circulating estradiol and greater subsequent concentration of progesterone than non-estrous cows. Increasing the number of beef cows in estrus at the same time also increased the number of times a cow was mounted and the duration of estrus (Floyd et al., 2009) and may increase the possibility of identifying more cows with less overt estrus expression in order to inseminate them at a more proper time in a split-time AI program.

Increased proportion of cows displaying estrus and becoming pregnant is also associated with greater conceptus size at d 19 of pregnancy and greater abundance of transcriptions for proteins in the endometrium that are favorable to pregnancy (Davoodi et al., 2015). Heifers inseminated after expressing estrus also had better quality embryos at a more advanced physiological stage than heifers not expressing estrus (Larimore et al., 2015). Acidification of the uterus (pH 7.0 to 6.7) occurs in cows that express estrus (Perry and Perry, 2008a,b) and prolonged viability of sperm has been associated with decreased intracellular sperm pH (Jones and Bavister, 2000).

It is clear that the uterine environment and endocrine milieu is more suitable for fertilization and embryo development in cows that express estrus when compared with those that do not. Recent research in beef cattle induced to ovulate immature follicles indicates that deficient uterine function is a major factor responsible for infertility in these cows (Bridges et al., 2013). Failure to produce adequate concentrations of estradiol before ovulation results in delayed effects of expression and localization of uterine genes and proteins that participate in regulating uterine functions during early gestation (Bridges et al., 2103).

Pregnancy risk was consistently greater in cows that expressed estrus up through 75 h (64.2 to 64.8%) except for the lesser PR (46%) in the EE cows that expressed estrus. This lesser PR could be attributed to GnRH-induction of smaller follicles lacking insufficient estradiol to induce sexual behavior and estrus by 60 h, but did not reduce subsequent estrus expression compared with cows that received GnRH at 75 h. In contrast, the ED cows expressing estrus also received GnRH at 60 h, but had greater pregnancy risk. Therefore, lack of subsequent estradiol production and estrus may not explain the poorer PR, rather the timing of the insemination or

insufficient uterine function because of inadequate estradiol associated with estrus expression are possible explanations (Bridges et al., 2013).

The classic work reported by Saacke (2008) illustrates the importance of insemination timing relative to the onset of estrus. In those studies, cows inseminated near the onset of estrus tended to have lesser fertilization risk but greater embryonic quality compared with cows inseminated at 24 h after the onset of estrus, in which fertilization risk was greater but embryo quality was compromised. Therefore, Saacke (2008) conclude that inseminating cows according the traditional a.m.-p.m. is a compromise of achieving maximal fertilization success and maintaining embryo quality compared with inseminating very early or very late relative to the onset of estrus.

In light of those conclusions, perhaps the poorer PR in EE cows inseminated at 60 h was similar to PR in cows in which inseminations were made early in estrus that resulted in lesser fertilization risk but greater embryo quality than that for ED cows, resulting in the difference in PR being related to more fertilization failure in the EE cows. Compared with beef heifers not exhibiting estrus before TAI, however, heifers that expressed estrus had improved embryo quality and advanced embryo stage on d 6 and increased the number of accessory sperm associated with the embryo (Larimore et al., 2015). Therefore, differences in PR between the EE and ED cows, which exhibited estrus, may be attributed to differences in uterine environment, fertilization risk, or embryo quality.

Strategies to increase the proportion of cows in estrus exposed to TAI systems may be valuable; however, the actual expression of estrus (79 to 85%) reported previously (Wilson et al., 2010) during 36 through 144 h after PGF_{2α} indicates that strategies to more closely synchronize estrus or ovulation and timing of insemination may have the greatest opportunity for success. In

the current study we observed more than 75% of cows exhibiting estrus by 75 h after CIDR insert removal and PGF_{2α} injection, regardless of cyclicity, parity, or days postpartum. The recommended optimal insemination time of 66 h after CIDR removal is not ideal for up to 53.7% of the cows in the present study that had not displayed estrus by 60 h. The results of the current study indicate that primiparous cows display estrus earlier than multiparous cows. This observation corroborates results of an earlier study (Dobbins et al., 2009) in which younger cows were more fertile when inseminated at an earlier fixed time (≤ 56 h after CIDR insert removal) than multiparous cows. A possible bimodal distribution of estrus between primiparous and multiparous cows indicates that insemination at 2 distinct times determined by estrus detection would result in more cows being inseminated after estrus expression.

The distribution of estrus in cows reported by Wilson et al. (2010) indicated that approximately 50% of cows exhibited estrus by 60 h after CIDR removal. We chose 60 h as the timing of the first AI, and observed that 46% of cows expressed estrus by 60 h. We chose 75 h after CIDR insert removal for the second AI time to coincide with the 12- to 16-h interval from beginning of estrus expression to maximum conception risk in dairy cows (Stevenson et al., 2014). Although estrus expression by 75 h was not influenced by days postpartum indicating that progestin-based synchronization programs are effective at inducing estrus and presumably ovulation in non-cyclic cows, parity-BCS interactions were detected, with better-conditioned primiparous cows having the greatest expression by 75 h. All cows that expressed estrus preceding AI had greater PR than their non-estrous herd mates, indicating that regardless of insemination time, it was preferable to inseminate after estrus. The EE cows that were inseminated at 60 h had lesser PR than any other treatment, despite receiving GnRH before AI. Timing of GnRH injection at either 60 or 75 h did not affect either subsequent estrus expression

or PR indicating some flexibility in applying these procedures in commercial operations. The GnRH injection concurrent with insemination may be unnecessary in single fixed time AI systems when estrus is detected (Perry and Perry, 2009). The importance of concurrent GnRH injection in cows displaying estrus has not been tested in a split timed AI system, however increasing the number of cows inseminated after estrus has the potential to reduce the reliance on induced ovulation via exogenous GnRH treatment.

In a similarly conducted study utilizing sex-sorted semen, increases in PR were noted when utilizing 2 AI times (Thomas et al., 2014a). In another study examining 2 AI times with conventional semen, no difference in PR was detected between early and later-inseminated non-estrous cows (Thomas et al., 2014b). It is likely that the difference in results noted between the latter study and the current study is the choice of insemination times relative to CIDR insert removal. In the current study, it is probable that the second insemination was closer to the optimal time between semen placement and ovulation for cows that exhibited estrus between 60 and 75 h when compared with the second insemination timing of 86 h in the previous report (Thomas et al., 2014b).

In summary, delaying the insemination of cows to 75 h when not detected in estrus by 60 h increased the PR compared with like cows inseminated at 60 h regardless of whether GnRH was injected at 60 or 75 h. By delaying insemination of non-estrous cows to 75 h, the number of cows inseminated after exhibiting estrus was increased. Pregnancy risk was consistently greater in cows that had displayed estrus before TAI.

LITERATURE CITED

- Bellows, R. A., R. E. Short, and G. V. Richardson. 1982. Effects of sire, age of dam and gestation feed level on dystocia and postpartum reproduction. *J. Anim. Sci.* 55:18–27.
- Bridges, G. A., M. L. Day, T. W. Geary, and L. H. Cruppe. 2013. Deficiencies in the uterine environment and failure to support embryonic development. *J. Anim. Sci.* 91:3002-3013. doi: 10.2527/jas.2013-5882.
- Busch, D. C., D. J. Schafer, D. J. Wilson, D. A. Mallory, N. R. Leitman, J. K. Haden, M. R. Ellersieck, M. F. Smith, and D. J. Patterson. 2008. Timing of artificial insemination in postpartum beef cows following administration of the CO-Synch + controlled internal drug release protocol. *J. Anim. Sci.* 86:1519–1525. doi: 10.2527/jas.2008-0925.
- Busch, D. C., D. J. Wilson, D. J. Schafer, N. R. Leitman, J. K. Haden, M. R. Ellersieck, M. F. Smith, and D. J. Patterson. 2007. Comparison of progestin-based estrus synchronization protocols before fixed-time artificial insemination on pregnancy rate in beef heifers. *J. Anim. Sci.* 85:1933–1939.
- Davoodi, S., R. F. Cooke, A. C. C. Fernandes, B. I. Cappellozza, J. L. M. Vasconcelos, and R. L. A. Cerri. 2015. Expression of estrus modifies the gene expression profile in reproductive tissues on Day 19 of gestation in beef cows. *Theriogenology* in press:1–11. doi: 10.1016/j.theriogenology.2015.10.002.
- Dobbins, C. A., D. R. Eborn, D. E. Tenhouse, R. M. Breiner, S. K. Johnson, T. T. Marston, and J. S. Stevenson. 2009. Insemination timing affects pregnancy rates in beef cows treated with CO-Synch protocol including an intravaginal progesterone insert. *Theriogenology.* 72:1009–1016. doi: 10.1016/j.theriogenology.2009.06.025.

- Floyd, L. N., C. A. Lents, F. J. White, and R. P. Wettemann. 2009. Effect of number of cows in estrus and confinement area on estrous behavior of beef cows. *J. Anim. Sci.* 87:1998–2004. doi: 10.2527/jas.2008-1380.
- Hill, S. L., G. A. Perry, V. R. Mercadante, G. C. Lamb, J. R. Jaeger, KC Olson, J. S. Stevenson. 2014. Altered progesterone concentrations by hormonal manipulations before a fixed-time artificial insemination CO-Synch + CIDR program in suckled beef cows. *Theriogenology*. 82:104–13. doi: 10.1016/j.theriogenology.2014.03.008.
- Jones, J. M., and B. D. Bavister. 2000. Acidification of intracellular pH in bovine spermatozoa suppresses motility and extends viable life. *J. Androl.* 21:616–624.
- Larimore, E. L., O. L. Amundson, S. L. Bird, B. J. Funnell, S. G. Kruse, G. A. Bridges, and G. A. Perry. 2015. Influence of estrus at fixed-time artificial insemination on early embryonic development in beef cattle. *J. Anim. Sci.* 93:2806–2812. doi: 10.2527/jas.2015-8892.
- Perry, G. A., and B. L. Perry. 2008a. Effect of preovulatory concentrations of estradiol and initiation of standing estrus on uterine pH in beef cows. *Domest. Anim. Endocrinol.* 34:333–338.
- Perry, G. A., and B. L. Perry. 2008b. Effects of standing estrus and supplemental estradiol on changes in uterine pH during a fixed-time artificial insemination protocol. *J. Anim. Sci.* 86:2928–2935. doi: 10.2527/jas.2008-1181.
- Perry, G. A., and B. L. Perry. 2009. GnRH treatment at artificial insemination in beef cattle fails to increase plasma progesterone concentrations or pregnancy rates. *Theriogenology*. 71:775–779. doi:10.1016/j.theriogenology.2008.09.050.

- Perry, G. A., M. F. Smith, M. C. Lucy, J. A. Green, T. E. Parks, M. D. MacNeil, A. J. Roberts, and T. W. Geary. 2005. Relationship between follicle size at insemination and pregnancy success. *Proc. Natl. Acad. Sci. USA* 102:5268–5273.
- Saacke, R. G. 2008. Insemination factors related to timed AI in cattle. *Theriogenology* 70:479-484.
- Stevenson, J. S., S. L. Hill, R. L. Nebel, and J. M. DeJarnette. 2014. Ovulation timing and conception risk after automated activity monitoring in lactating dairy cows. *J. Dairy Sci.* 97:4296–4308. doi: 10.3168/jds.2013-7873.
- Stevenson, J. S., S. L. Pulley, and H. I. Mellieon Jr. 2012. Prostaglandin F_{2α} and gonadotropin-releasing hormone administration improve progesterone status, luteal number, and proportion of ovular and anovular dairy cows with corpora lutea before a timed artificial insemination program. *J. Dairy Sci.* 95:1831–44. doi: 10.3168/jds.2011-4767.
- Thomas, J. M., S. L. Lock, S. E. Poock, M. R. Ellersieck, M. F. Smith, and D. J. Patterson. 2014a. Delayed insemination of nonestrous cows improves pregnancy rates when using sex-sorted semen in timed artificial insemination of suckled beef cows. *J. Anim. Sci.* 92:1747–1752. doi: 10.2527/jas.2013-7131.
- Thomas, J. M., S. E. Poock, M. R. Ellersieck, M. F. Smith, and D. J. Patterson. 2014a. Delayed insemination on non-estrous heifers and cows when using conventional semen in artificial insemination. *J. Anim. Sci.* 92:4189–4197. doi: 10.2527/jas.2014-7827.
- White, F. J., R. P. Wettemann, M. L. Looper, T. M. Prado, and G. L. Morgan. 2002. Seasonal effects on estrous behavior and time of ovulation in nonlactating beef cows. *J. Anim. Sci.* 80:3053–3059.

Wilson, D. J., D. A. Mallory, D. C. Busch, N. R. Leitman, J. K. Haden, D. J. Schafer, M. R.

Ellersieck, M. F. Smith, and D. J. Patterson. 2010. Comparison of short-term progestin-based protocols to synchronize estrus and ovulation in postpartum beef cows. *J. Anim. Sci.* 88:2045–2054. doi: 10.2527/jas.2009-2627.

Table 2.1.

Selected characteristics of suckled beef cows enrolled in experiment

Location ¹	Breed	<i>n</i>	2 yr. old (%)	Mean (± SE) days postpartum at AI	Mean (± SE) BCS	Cyclicity ² (%)
CO-1	Angus x Hereford	93	28	74 ± 1.7	5.8 ± 0.07	... ³
KS-1	Angus x Hereford	178	0	93 ± 1.1	5.7± 0.03	96
KS-2	Angus x Hereford	18	0	74 ± 3.9	6.4± 0.14	44
KS-3	Angus x Hereford	57	0	67 ± 2.9	6.9 ± 0.11	74
KS-4	Angus, Hereford, Simmental	65	0	75 ± 1.7	4.8 ±0.07	66
KS-5	Angus x Hereford	51	20	65 ± 1.6	4.5 ± 0.06	59
KS-6	Angus x Hereford	29	0	61 ± 4.2	6.8 ± 0.11	59
IL-1	Angus x Hereford	150	0	67 ± 1.0	5.2 ± 0.06	... ³
MN-1	Angus x Hereford	124	15	69 ± 2.3	4.9 ± 0.06	61
MS-1	Angus, Hereford	50	19	67 ± 2.8	5.4 ± 0.08	... ³
MT-1	Angus	95	35	73 ± 1.6	4.8 ± 0.08	³
ND-1	Angus x Hereford	173	21	71 ± 0.9	5.4 ± 0.05	... ³
SD-1	Angus x Hereford	102	28	81 ± 1.5	5.6 ± 0.04	32
VA-1	Angus x Simmental	209	15	79 ± 1.4	4.5 ±0.06	62
VA-2	Angus x Simmental	213	16	75 ± 1.2	4.2 ± 0.04	52

¹ Cows at 15 locations in 9 states were enrolled.² Cyclicity was based on progesterone concentrations measured in 2 blood samples collected 10 d apart before the onset of the experimental protocol.³ Blood samples were not collected to assess cyclicity.

Table 2.2.

Estrus expression by 60, between 60 and 75 h, and by 75 h after CIDR insert removal as affected by BCS, parity, and days postpartum

Item	Days			<i>n</i>	Estrus (%)
	postpartum	BCS	Parity		
Estrus by 60 h					
Days postpartum	≤ 75	773	54.8
	> 75	838	52.7
BCS x parity	...	> 5	1	86	69.2 ^a
	...	≤ 5	1	142	48.9 ^b
	...	> 5	2+	608	49.1 ^b
	...	≤ 5	2+	775	46.7 ^b
Estrus between 60 and 75 h					
Days postpartum	≤ 75	400	47.0
	> 75	465	46.8
BCS	...	> 5	...	341	52.3 ^a
	...	≤ 5	...	524	41.5 ^b
Parity	1	106	43.7
	2+	759	50.1
GnRH at 60 h	574	47.7
GnRH at 75 h	291	52.2
Estrus by 75 h					
Days postpartum	≤ 75	773	77.7
	> 75	838	76.2
BCS x parity	...	> 5	1	86	87.0 ^a
	...	≤ 5	1	143	68.0 ^b
	...	> 5	2+	608	77.2 ^c
	...	≤ 5	2+	775	72.0 ^{bc}

^{abc} Means within category with different superscript letters differ ($P < 0.05$).

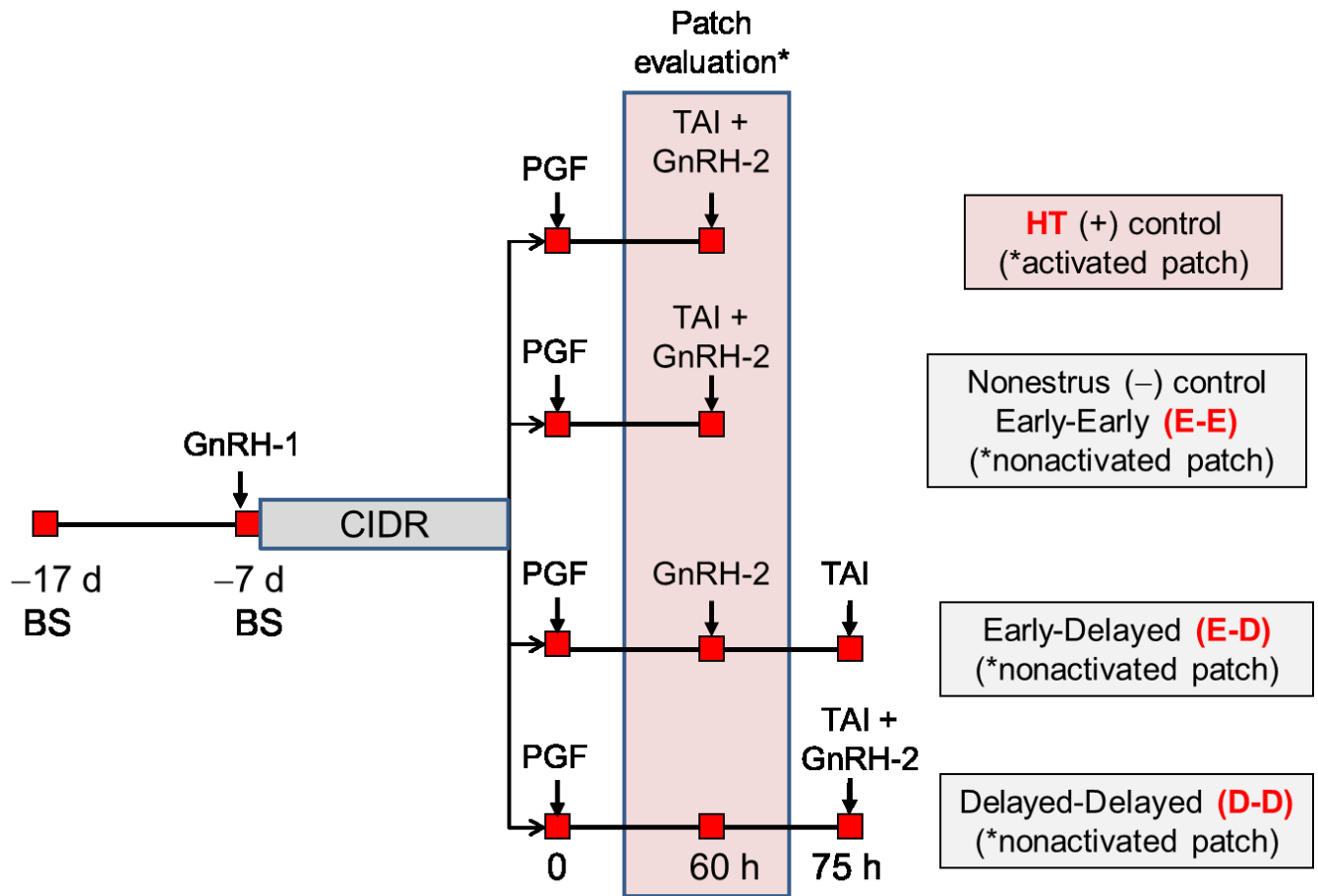

Figure 2.1.

Experimental design of treatments. The HT (n = 746) and EE (n = 292) cows received an injection of GnRH (GnRH-1) and an intravaginal controlled internal drug release (CIDR) insert containing 1.38 g of progesterone on study d -7, an injection of PGF_{2α} (PGF) and CIDR insert removal on d 0, and an injection of GnRH (GnRH-2), and AI 60 h later. The ED cows (n = 282) received GnRH-2 at 60 h, but were inseminated at 75 h. The DD cows (n = 291) received GnRH-2 and insemination at 75 h. Blood samples were collected on d -17, and -7 from a subset of cows (n = 1,046) at 10 of 14 locations. Estrus-detection patches were considered activated when more than 50% of the covering material was removed by either 60 or 75 h.

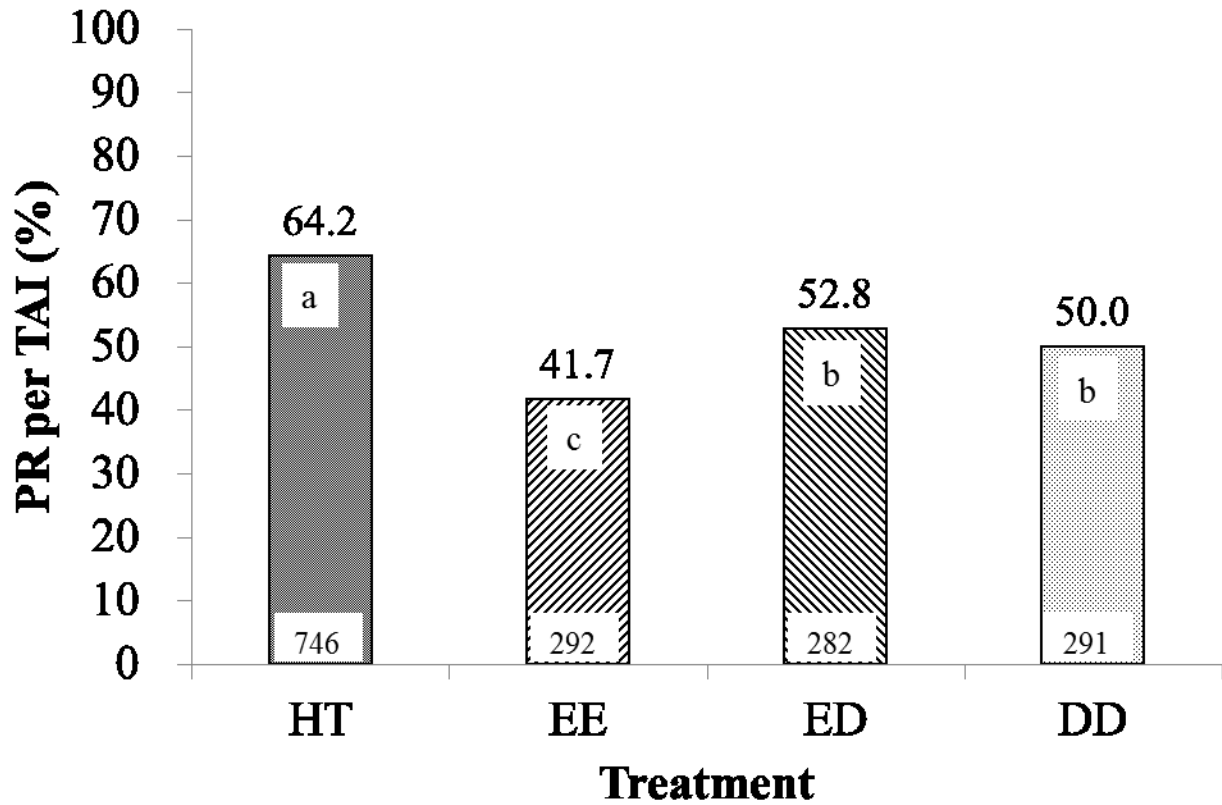

Figure 2.2

Pregnancy risk (PR) per timed AI (TAI) by treatment. Control cows (HT) were detected in estrus by 60 h, inseminated and received GnRH at 60 h. The remaining cows were allocated to 3 treatments: 1) injected with GnRH and inseminated at 60 h (early-early; EE); 2) injected with GnRH at 60 h but inseminated at 75 h (early-delayed; ED); or 3) injected with GnRH and inseminated at 75 h (delayed-delayed; DD). Bars with different letters differ ($P < 0.01$). Values within each bar represent the number of observations.

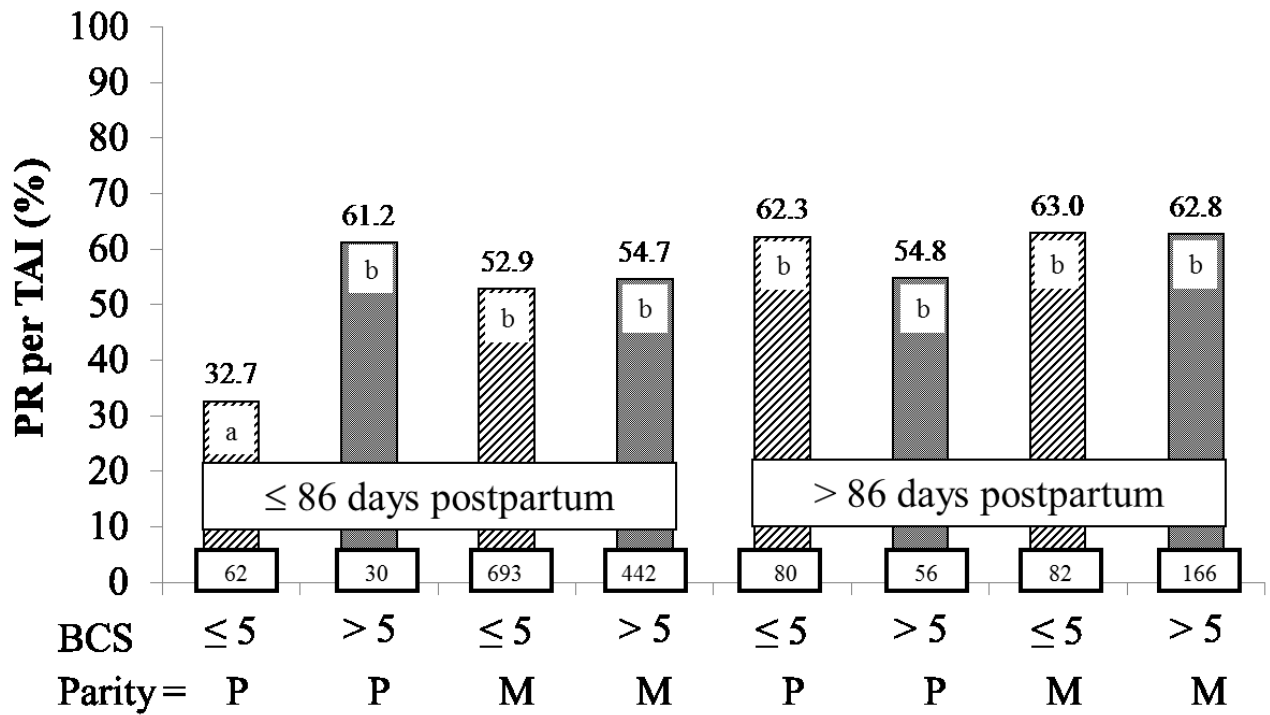

Figure 2.3

Pregnancy risk (PR) per timed AI (TAI), illustrating the 3-way interaction among BCS, parity (primiparous [P] and multiparous [M]), and days postpartum. The values at the base of the bars reflect the number of cows in each sub-group. Bars with different letters differ ($P < 0.05$).

Chapter 3 - GnRH increased pregnancy risk in suckled beef cows not detected in estrus and subjected to a split-time artificial insemination program

INTRODUCTION

Estrus-synchronization programs allow insemination of all females in a herd at one fixed-time on the first day of a breeding season. Inseminating cows after they have expressed estrus increases pregnancy risk (PR) compared with cows that do not display estrus in a timed AI (TAI) program (Richardson et al., 2016). Identification of estrus status can be facilitated by using estrus-detection patches. Varying AI timing according to estrus status has increased PR in some (Markwood et al., 2014; Thomas et al., 2014 a; Hill et al., 2016), but not all studies (Thomas et al., 2014 b). Reducing the number of injections in a TAI program decreases labor requirements, stress on cows, and overall cost of the program. Previous studies have demonstrated that PR is not compromised in cows displaying estrus when the GnRH injection concurrent with AI is eliminated (Perry and Perry, 2009). A split time AI program decreases the time between estrus expression and insemination compared with a single fixed-time AI when the first AI occurs before the recommended standard 60 to 66 h fixed time. Delaying AI results in approximately 50% more cows displaying estrus prior to AI when compared with a single insemination time (Hill et al., 2016). Eliminating the GnRH injection at the time of AI for cows displaying estrus in a split TAI program reduces the number of GnRH injections required and program cost. The objective of this study was to test the hypothesis that GnRH injection concurrent with split TAI program improves PR only in cows not displaying estrus.

MATERIALS AND METHODS

Experimental Design

The Kansas State University Animal Care and Use Committee approved all experimental procedures (protocol no. 3392). A total of 1,236 mixed parity suckled beef cows at 12 locations in 3 states (CO, KS, and ND) were enrolled in the experiment. Body condition scores (1 = thin; 9 = very fat; Bellows et al., 1982) were assigned (d -17) before the start of the TAI program by a trained evaluator (Figure 1). Characteristics of suckled beef cows enrolled by location including breed, parity, days postpartum at split TAI, and BCS at the onset of the synchronization program are summarized (Table 3.1). All cows were treated with a 100 µg GnRH (2 mL Factrel, Zoetis, Florham Park, NJ) 7 d before 25 mg PGF_{2α} on d 0 (5 mL Lutalyse; Zoetis). A new progesterone-impregnated controlled internal drug release (CIDR) insert (Zoetis) containing 1.38 g progesterone was placed intravaginally at the time of the GnRH injection (d -7). On d 0, concurrent with CIDR insert removal, estrus-detection patches (Estroject, Spring Valley, WI) were affixed to the tail head of all cows according to manufacturer's recommendation. Patches were evaluated at 65 h after CIDR removal and estrus was defined to have occurred when an estrus-detection patch was > 50% colored (activated). Cows with activated patches were assigned by random chute order to either receive 100 µg GnRH and concurrent early AI (**E+G**) or only AI (**E-G**) at 65 h. Remaining non-estrus cows received either GnRH injection (**L+G**) or no treatment at 65 h (**L-G**) and were inseminated later at 84 h. An additional evaluation of patch activation status was also conducted at 84 h to determine if activation had occurred between 65 and 84 h.

Pregnancy Diagnosis

Cows were either observed for estrus and re-inseminated upon subsequent estrus or exposed to cleanup bulls beginning 10 to 12 d after split TAI. At 35 d after split TAI, pregnancy (PR) was confirmed by transrectal ultrasonography (Aloka 500V, 5 MHz transrectal transducer, Wallingford, CT). A positive pregnancy outcome required presence of a corpus luteum and uterine fluid or an embryo with a heartbeat. A final pregnancy diagnosis was determined via transrectal ultrasonography or palpation per rectum at least 35 d after the end of the breeding season (removal of natural service sires). Pregnancy loss was defined as those cows pregnant 35 d after split TAI but not at the time of the final pregnancy diagnosis.

Estrus-Cycle Status

Blood samples were collected via puncture of a caudal blood vessel from cows ($n = 434$) at 8 of the 12 locations on d -17 and -7 . Concentrations of progesterone in blood serum were measured in all samples by direct quantitative (nonextracted) radioimmunoassay using ImmuChem Double Antibody progesterone ^{125}I kits (Catalog # 07-170105; (MP Biomedicals LLC, Orangeburg, NY) and validated for bovine serum. The radioligand was ^{125}I labeled progesterone (1,500 to 2,000 $\mu\text{Ci}/\mu\text{g}$). The anti-progesterone antibody was generated in rabbits using 11α -hydroxyprogesterone- 11α -hemisuccinate-human serum albumin as the antigen. Kit standards (0.05, 0.1, 0.5, 2, 5, 10, 25, and 50 ng/mL), to which we added 2 more standards of 0.05 and 0.1 ng/mL, unknowns, and assay pools were added (100 μL each) in duplicate to 12 x 75 mm plastic conical tubes. Next, 500 μL of anti-progesterone and 200 μL of ^{125}I labeled progesterone were added to each tube, vortexed for 5 s, and incubated for 1 h in a water bath at 37°C . Next, 500 μL of a precipitant solution was added to all tubes and thoroughly vortexed for 10 s before centrifuging at 5°C for 30 min at 5,000 x g. Tubes were then decanted, blotted on

paper towels, and radioactivity of each tube was quantified for 1 min in a gamma counter. Recovery of added mass in triplicate to 100 μ L of 4 different bovine serum samples (0.39, 1.38, 3.67, and 13.72 ng/mL) averaged 101.5%. Parallelism was demonstrated by assaying 50-, 75- and 100- μ L aliquots of bovine serum at 2 different concentrations in quadruplicate and recovering 105.5% added mass. Duplicate unknowns that failed to replicate within 10% were re-assayed. Intra-assay CV for progesterone was 5.6 %. Inter-assay CV for the low and high pool was 11.9 and 9.3 %, respectively. Assay sensitivity was 53.4 ± 14.4 pg/mL.

Cows with a serum progesterone concentration ≥ 1.0 ng/mL at either d -17 or -7 were defined to have resumed estrous cycles (Ireland et al., 1980). All other cows were considered to have been anestrous at the onset of the ovulation synchronization program (Table 3.1).

Statistical Analyses

Median value of the continuous variables BCS (< 5 vs. ≥ 5) and days postpartum (≤ 82 vs. > 82) were used to create corresponding binomial variables. Each of the dependent variables (cyclic status, estrus expression at 3 time intervals (by 65 h, 65 through 84 h, and by 84 h), PR, final PR, and pregnancy loss) was regressed on the independent variables in procedure LOGISTIC (SAS Inst. Inc., Cary, NC). A final model was produced using the stepwise selection method with a P value < 0.30 for inclusion and $P < 0.15$ for retention in the model. The independent fixed variables: BCS, days postpartum, parity, and all interactions of these variables were initially included in the selection for cycling status. A final model produced by backward stepwise selection of independent variables entered or retained in the model was based on a Wald statistic ($P < 0.10$).

Similar selection procedure was performed with the remaining outcome variables with the following inclusions; cycling status was added as an independent variable in the remaining

models, total estrus expression was added to the models analyzing PR and loss and treatment was added to all models. The list of variables measured and the factors included in the final model are summarized in Table 3.2.

The GLIMMIX procedure (method = laplace; ilink = logit dist = binomial solution oddsratio) in SAS was used to analyze the binomial outcome variables. Differences of means calculated using unequal sample sizes were adjusted using the Bonferroni adjustment. An additional GLIMMIX model with PR as the dependent variable was constructed to examine the interaction of GnRH injection and estrus expression for the cows inseminated at 84 h. The location of each herd was included in all models as a random variable. Differences were considered to be significant at $P \leq 0.05$.

RESULTS

Pregnancy Risk

Cows detected in estrus and inseminated at 65 h had greater PR than the cows inseminated at 84 h regardless of GnRH treatment (Figure 2). Pregnancy risk was not improved ($P = 0.68$), however, by administration of GnRH in cows that were in estrus by 65 h (61.9 and 60.4% for E+G and E-G, respectively). For cows inseminated at 84 h, PR was greater ($P = 0.001$) in cows that received GnRH at 65 h (L+G) compared with their herd mates not receiving GnRH at 65 h (41.7 and 30.8% for L+G and L-G, respectively).

Four cows were eliminated from the analysis of PR because patch data were not available at 84 h. Administration of GnRH at 65 h increased ($P < 0.01$) pregnancy risk in cows not detected in estrus by 84 h (Figure 3). In contrast, administration of GnRH did not impact PR ($P = 0.60$) in cows expressing estrus during the interval from 65 to 84 h. Pregnancy risk for cows inseminated at either time was not affected ($P \geq 0.10$) by BCS, parity, or days postpartum at AI. Final PR for

E+G, E-G, L+G, and L-G cows were 87.4, 89.0, 84.5, and 78%, respectively. Final PR of L-G cows differed from E+G ($P = 0.02$) and E-G ($P = 0.004$). Body condition score did not affect final PR. An interaction ($P = 0.05$) was detected between days postpartum and parity when considering the final PR. Primiparous cows that were ≤ 82 d postpartum had a lesser ($P = 0.003$) final PR than primiparous cows > 82 d (70.9 vs. 87.6%). Final PR of primiparous cows ≤ 82 d postpartum also differed ($P = 0.01$) from that of multiparous cows ≤ 82 d and multiparous cows > 82 d (87.8, and 89.7 %), respectively.

Pregnancy loss (1.3 %) between 35 d after TAI and final pregnancy status after the end of the breeding season did not differ among treatments ($P = 0.89$) and was not affected ($P \geq 0.14$) by BCS, days postpartum, or parity.

Occurrence of Estrus

Activated estrus-detection patches were observed in 61.3% (758/1,236) of cows at 65 h after insert removal. Of the remaining cows, 42.1% (201/478) had activated estrus-detection patches at 84 h indicating estrus had occurred between 65 and 84 h. In total, 77.6 % (959/1,236) of cows were observed with activated estrus-detection patches by 84 h.

The proportion of cows expressing estrus expression by 65 h was not impacted ($P > 0.10$) by BCS, parity, days postpartum, or their respective interactions (Table 3.3). Likewise, proportion of cows expressing estrus during the interval from 65 to 84 h was not influenced ($P > 0.10$) by BCS, parity, days postpartum, or their respective interactions. A greater proportion of cows > 82 d postpartum tended ($P = 0.09$) to express estrus by 84 h compared with cows ≤ 82 d postpartum (79.8 vs. 75.5%), respectively.

Estrus-cycle status based on concentrations of progesterone was examined for its effect on occurrence of estrus in the subset of 434 cows for which that information was available. Analysis

of the impact of estrus-cycle status on estrus expression revealed that similar ($P > 0.26$) proportions of cycling and anestrus cows were detected in estrus in each of the 3 observation periods (51 vs. 58 % by 65 h, 25 vs. 28% between 65 and 84 h, and 65 vs. 70% by 84 h) for cycling and anestrus cows, respectively. The proportion of cows that had resumed estrous cycles (32.0 %; 139/434) was neither influenced by BCS nor days postpartum. Primiparous cows, however, were more ($P < 0.01$) likely to be anestrus than their multiparous herd mates (94.6 vs. 63.6%), respectively.

DISCUSSION

The current experiment demonstrates that GnRH is not essential to achieve acceptable PR (> 60%) when cows had expressed estrus before AI at 65 h. More importantly, for cows not detected in estrus by 65 h, treatment with GnRH was only essential to enhance PR when cows were inseminated at the 84 h and had not expressed estrus. We assume that the majority of cows observed to have had activated estrus detection patches by 65 h were exposed to their own GnRH-induced LH surge and subsequently ovulated spontaneously. Programs that use 2 insemination times determined by occurrence of estrus allow for a closer alignment of the spontaneous LH surge and subsequent ovulation negating the need for exogenous GnRH in cows that display estrus. Treating cows that did not display estrus with GnRH increased PR 2 fold compared with untreated cows. Furthermore, use of estrus-detection patches to identify estrus accurately seems to be validated by the PR achieved (> 60%) in cows not exposed to exogenous GnRH before TAI, regardless of time of AI.

In cows that display estrus spontaneously, ovulation occurs 31 h after the initiation of estrus (White et al., 2002). Administering GnRH near the onset of estrus may induce the LH surge or augment the magnitude of the LH surge from the pituitary (Lucy and Stevenson, 1986); however,

circulating concentrations of LH are only minimally influenced by exogenous GnRH after the spontaneous LH surge in dairy cows (Lucy and Stevenson, 1986; Pulley et al., 2015). In an previous experiment conducted in beef cows that were detected in estrus, no increase was detected in the proportion of cows becoming pregnant after AI when GnRH was administered at the time of AI (Perry and Perry, 2009). In that study, cows were subjected to AI between 6 and 18 h after estrus was first detected. In a TAI program, the interval from initiation of estrus until AI is quite variable, this may change the effectiveness of a GnRH injection concurrent with AI. Cows that ovulate after AI in a TAI program, and therefore have the opportunity to conceive, can be grouped into the classifications of those that ovulate spontaneously and those that are induced to ovulate after exogenous GnRH-induced LH release. Timing of the GnRH treatment in relationship to AI in cows that do not display estrus should be examined more closely. In the current study, cows that were detected in estrus either before the first (65 h) or second (84 h) split-time AI had no improvement in PR after split TAI when treated with GnRH compared with untreated herd mates.

In split TAI programs, cows are treated differently based on the occurrence of estrus (Thomas et al., 2014a). The current study and previous research indicates that more than 50% of cows in a split TAI program displayed estrus by 65 h (Thomas et al., 2014, Hill et al., 2016). In previous research (Hill et al. 2016), time to the first assessment of estrus was 60 h after CIDR insert removal, resulting in 46.3% of cows in estrus compared with 61.3% of cows detected by 65 h in the current study. Furthermore, for cows not detected in estrus by 60 h in the latter study, administration of GnRH at either 60 h (15 h before AI) or 75 h (concurrent with AI), produced similar PR. For cows not detected in estrus between 60 and 75 h in the latter study, PR was numerically greater at 46% (n = 139) compared with 39.1% (n = 133) when GnRH was

administered at 60 vs. 75 h, respectively, and AI occurred at 75 h. The earlier time of the first split-time AI will likely result in a smaller proportion of cows in estrus and more cows requiring GnRH before the second-split-time AI. Therefore, timing of estrus may be quite important relative to the selected first and second split-time so further examination of insemination timing in a split TAI program is warranted.

The initial studies utilizing the Ovsynch and CO-Synch programs in beef cattle demonstrated the importance of administering GnRH to induce ovulation either concurrent or before insemination in a 7-d TAI system (Geary et al., 1998). Interval from PGF_{2α} injection to spontaneous ovulation in TAI systems varies depending on the prior estrus-cycle status, parity, and the stage of the estrous cycle at the initiation of the procedure (Geary et al., 2000). Results of the current experiment indicate that the increase in PR from GnRH treatment was associated with cows that did not display estrus.

Previous studies have identified conditions that alter the proportion of cows that display estrus at a given time or in total. Postpartum suckled cows that are anestrous at the onset of TAI programs seem to display estrus earlier than their estrus-cycling herd mates (Geary et al., 2000; Stevenson et al., 2000; Busch et al., 2008), which was not verified in the present study. Previous cyclic status did not influence when cows were detected in estrus. Cows with a lesser BCS, however, are less likely to display estrus than cows with a greater BCS (Richardson et al., 2016). Stage of the estrous cycle at the initiation of the synchronization program for heifers that are cycling can alter the timing of estrus (Atkins et al., 2008). Furthermore, variations in the response to GnRH have been identified in beef cows depending on the stage of their follicular wave and their previous cycling status (Atkins et al., 2010 a, b). In our previous research, we noted that primiparous cows that have a BCS > 5 display estrus sooner than older or thinner

cows (Hill et al., 2016). In contrast, in the current study the timing of estrus after the removal of the CIDR insert was not affected by parity, BCS, or cycling status. It is possible that the different time after CIDR insert removal chosen to measure estrus masked some of these physiological causative factors. In our previous report (Hill et al., 2106), time to the first assessment of estrus was 60 h after CIDR insert removal, resulting in 46.3% of cows in estrus compared with 61.3% of cows detected by 65 h in the current study.

In summary, GnRH injection at AI only improves pregnancy risk in those cows that are not detected in estrus before time of AI. Cows that exhibited estrus regardless of GnRH treatment had better PR than cows that did not display estrus and do not profit from exogenous GnRH. Insemination at a predetermined time in beef cows can reduce the time and labor associated with conventional AI. The split-time AI program serves as a compromise between conventional AI after detection of estrus and a standard one-time fixed TAI program. The economic trade-off of using estrus-detection patches at approximately one-third of the cost of GnRH may provide economic incentive for applying split-time AI programs. Furthermore, cost of semen and sire selection for cows detected in estrus having resulting greater PR compared with those not detected in estrus having lesser PR, can provide advantages for employing a split-time AI program.

LITERATURE CITED

- Atkins, J. A., D. C. Busch, J. F. Bader, D. H. Keisler, D. J. Patterson, M. C. Lucy, and M. F. Smith. 2008. Gonadotropin-releasing hormone-induced ovulation and luteinizing hormone release in beef heifers: Effect of day of the cycle. *J. Anim. Sci.* 86:83–93. doi:10.2527/jas.2007-0277.
- Atkins, J. A., M. F. Smith, K. J. Wells, and T. W. Geary. 2010a. Factors affecting preovulatory follicle diameter and ovulation rate after gonadotropin-releasing hormone in postpartum beef cows. Part I: Cycling cows. *J. Anim. Sci.* 88:2300–2310. doi:10.2527/jas.2009-2531.
- Atkins, J. A., M. F. Smith, K. J. Wells, and T. W. Geary. 2010b. Factors affecting preovulatory follicle diameter and ovulation rate after gonadotropin-releasing hormone in postpartum beef cows. Part II: Anestrous cows. *J. Anim. Sci.* 88:2311–2320. doi:10.2527/jas.2009-2532.
- Bellows, R. A., R. E. Short, and G. V. Richardson. 1982. Effects of sire, age of dam and gestation feed level on dystocia and postpartum reproduction. *J. Anim. Sci.* 55:18–27.
- Busch, D. C., D. J. Schafer, D. J. Wilson, D. A. Mallory, N. R. Leitman, J. K. Haden, M. R. Ellersieck, M. F. Smith, and D. J. Patterson. 2008. Timing of artificial insemination in postpartum beef cows following administration of the CO-Synch + controlled internal drug release protocol. *J. Anim. Sci.* 86:1519–1525. doi:10.2527/jas.2008-0925.
- Geary, T. W., E. R. Downing, J. E. Bruemmer, and J. C. Whittier. 2000. Ovarian and estrous response of suckled beef cows to the Select Synch estrous synchronization protocol. *Prof. Anim. Sci.* 16:1–5.
- Geary, T. W., and J. C. Whittier. 1998. Effects of a timed insemination following synchronization of ovulation using the Ovsynch or CO-Synch protocol in beef cows. *Prof. Anim. Sci.* 14:217–220.

- Hill, S. L., D. M. Grieger, K.C. Olson, J. R. Jaeger, C. R. Dahlen, G. A. Bridges, F. Dantas, J. E. Larson, A. M. Muth-Spurlock, J. K. Ahola, M. C. Fischer, G. A. Perry, E. L. Larimore, T. L. Steckler, W. D. Whittier, J. F. Currin, and J. S. Stevenson. 2016. Using estrus-detection patches to optimally time insemination improved pregnancy risk in suckled beef cows in a fixed-time artificial insemination program. *J. Anim. Sci.* In review.
- Ireland, J. J., R. L. Murphee, and P. B. Coulson. 1980. Accuracy of predicting stages of bovine estrous cycle by gross appearance of the corpus luteum. *J. Dairy Sci.* 63:155–60.
- Lucy, M.C., and J.S. Stevenson. 1986. Gonadotropin-releasing hormone at estrus: Luteinizing hormone, estradiol, and progesterone during the periestrual and postinsemination periods in dairy cattle. *Biol. Reprod.* 35:300–311.
- Markwood, M. G., R.K. Peel, J. K. Ahola, G. E. Seidel Jr., R. N. Funston, S. L. Lake, and J. C. Whittier. 2014. Effect of delaying time AI based on ESTROTECT™ patch status on pregnancy rates of nursing beef cows. *Proc. West. Sect. ASAS* 65:79-82.
- Perry, G. A., and B. L. Perry. 2009. GnRH treatment at artificial insemination in beef cattle fails to increase plasma progesterone concentrations or pregnancy rates. *Theriogenology* 71:775–779. doi:10.1016/j.theriogenology.2008.09.050.
- Pulley, S. L., D. H. Keisler, and J. S. Stevenson. 2015. Concentrations of luteinizing hormone and ovulatory responses in dairy cows before timed artificial insemination. *J. Dairy Sci.* 98:6188–6201. doi:10.3168/jds.2015-9473.
- Richardson, B. N., S. L. Hill, J. S. Stevenson, G. D. Gemechis, and G. A. Perry. 2016. Expression of estrus before fixed-time AI affects conception rates and factors that impact expression of estrus and the repeatability of expression of estrus in sequential breeding seasons. *Anim. Reprod. Sci.* 166:133–140. doi:10.1016/j.anireprosci.2016.01.013.

Stevenson, J. S., K. E. Thompson, W. L. Forbes, G. C. Lamb, D. G. Grieger, and L. R. Corah.

2000. Synchronizing estrus and (or) ovulation in beef cows after combinations of GnRH, norgestomet, and prostaglandin $F_{2\alpha}$ with or without timed insemination. *J. Anim. Sci.* 78:1747–1758. doi:/2000.7871747x.

Thomas, J. M., S. L. Lock, S. E. Poock, M. R. Ellersieck, M. F. Smith, and D. J. Patterson.

2014a. Delayed insemination of nonestrous cows improves pregnancy rates when using sex-sorted semen in timed artificial insemination of suckled beef cows. *J. Anim. Sci.* 92:1747–1752. doi: 10.2527/jas.2013-7131.

Thomas, J. M., S. E. Poock, M. R. Ellersieck, M. F. Smith, and D. J. Patterson. 2014b. Delayed

insemination on non-estrous heifers and cows when using conventional semen in artificial insemination. *J. Anim. Sci.* 92:4189–4197. doi: 10.2527/jas.2014-7827.

White, F. J., R. P. Wettemann, M. L. Looper, T. M. Prado, and G. L. Morgan. 2002. Seasonal

effects on estrous behavior and time of ovulation in nonlactating beef cows. *J. Anim. Sci.* 80:3053–3059. doi:/2002.80123053x.

Table 3.1.

Selected characteristics of suckled beef cows enrolled in the experiment

Location ¹	Breed ²	<i>n</i>	2 yr. old (%)	Days postpartum at AI ³	BCS ³	Cycling status ⁴ (%)	Pregnancy risk ⁵ %
CO-1	A	333	26	83 ± 1.0	4.6 ± 0.02	... ⁶	58.9
CO-2	A	80	23	81 ± 1.9	5.5 ± 0.08	... ⁶	68.8
KS-1	H	39	28	78 ± 2.9	5.6 ± 0.08	33	66.7
KS-2	A x H	40	25	82 ± 2.6	5.7 ± 0.10	53	45.0
KS-3	A x H	77	31	84 ± 1.7	5.4 ± 0.07	61	49.4
KS-4	A x H	61	26	83 ± 1.8	5.4 ± 0.09	49	55.7
KS-5	A x H	64	86	78 ± 2.6	5.5 ± 0.08	6	23.4
KS-6	A x H	98	0	69 ± 1.8	5.7 ± 0.06	18	46.9
KS-7	A x H	29	0	49 ± 3.8	5.8 ± 0.07	14	51.7
KS-8	A x H	19	0	69 ± 4.2	5.3 ± 0.18	5	21.1
ND-1	A x H	190	0	72 ± 1.4	4.4 ± 0.04	... ⁶	68.9
ND-2	A x H	206	32	83 ± 1.2	4.3 ± 0.04	... ⁶	62.6

¹Cows at 12 locations in 3 states were enrolled.²A = Angus and H =Hereford.³Mean ± SE.⁴Estrus-cycling status was based on progesterone concentrations measured in 2 blood samples collected 10 d apart before the onset of the experimental protocol (cut point = 1 ng/mL).⁵Assessed at 35 d after AI.⁶Blood samples were not collected to assess cyclic status.

Table 3.2.

Composition of statistical model selections

Dependent variable	Independent variable	Interactions
Cycling status	Days ³ , parity	... ²
Estrus by 65 h	... ¹	... ²
Estrus from 65 to 84 h	... ¹	... ²
Estrus by 84 h	BCS, days ³ , parity	... ²
PR at 35 d	Days ³ , parity, treatment	... ²
PR 35 d after breeding season	Days ³ , parity, treatment	Days x parity
Pregnancy loss	BCS, days ³ , parity, treatment	... ²

¹No variables had lesser P value than the selection criteria ($P = 0.15$).

²No interactions had lesser P value than the selection criteria ($P = 0.15$).

³Days postpartum at split TAI.

Table 3.3.

Estrus expression by 65 h, between 65 and 84 h, and by 84 h after CIDR insert removal as affected by BCS, parity, days postpartum and GnRH

Item	Estrus by 65 h		Estrus between 65 and 84 h		Estrus by 84 h	
	<i>n</i>	%	<i>n</i>	%	<i>n</i>	%
Days postpartum						
≤ 82	600	61.1	230	37.9	600	75.5 ^a
> 82	643	65.8	246	41.6	643	79.8 ^b
BCS						
≥ 5	696	64.3	271	41.8	696	79.3
< 5	547	62.6	205	37.7	547	76.1
Parity						
Primiparous	287	64.2	119	37.5	287	77.1
Multiparous	956	62.7	357	42.0	956	78.4
GnRH at 65 h	250	40.9
No GnRH at 65 h	226	38.6

^{ab} Means within estrus category with different superscript letters tend ($P < 0.10$) to differ.

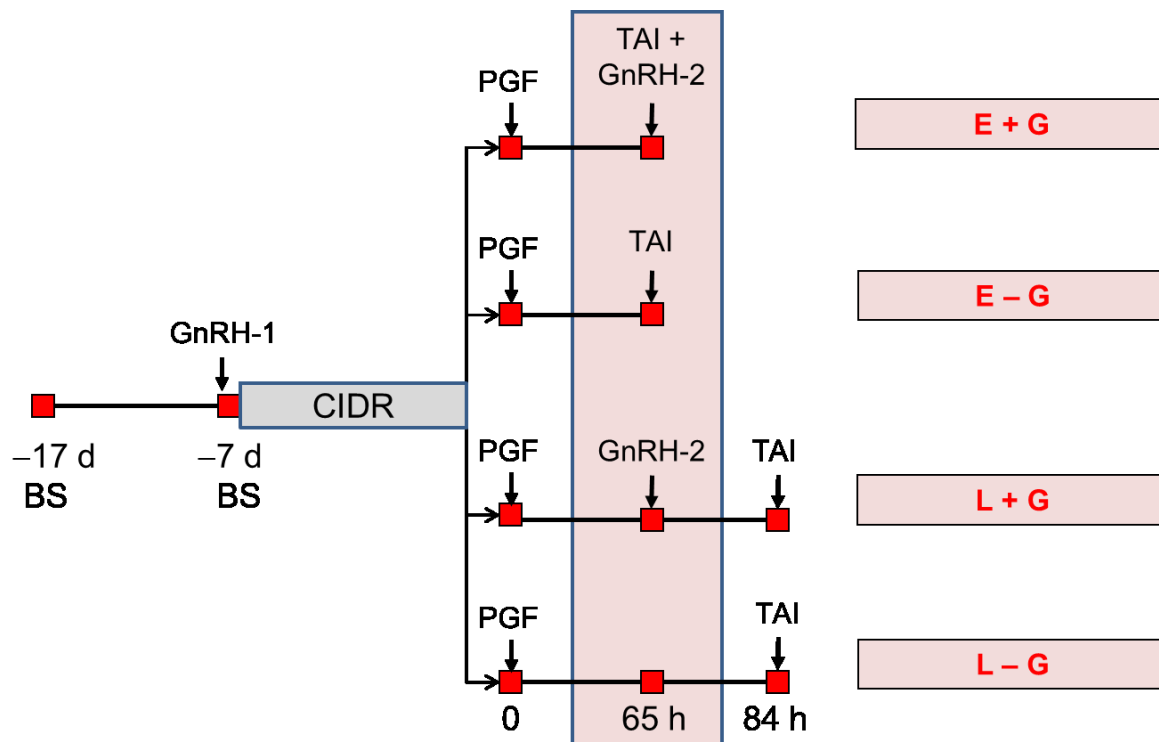

Figure 3.1

Experimental design of treatments. All cows ($n = 1,236$) received $100 \mu\text{g}$ GnRH i.m. (GnRH-1) and a controlled internal drug release (CIDR) insert containing 1.38 g of progesterone, followed in 7 d by 25 mg $\text{PGF}_{2\alpha}$ (PGF) and CIDR removal (d 0). Cows with patches $> 50\%$ activated were defined to be in estrus and treatment assignments were made at 65 h. The E+G cows ($n = 373$) received $100 \mu\text{g}$ GnRH (GnRH-2) and insemination at 65 h. The E-G cows ($n = 385$) received no GnRH and were inseminated at 65 h. The L+G cows ($n = 252$) received GnRH-2 at 65 h and were inseminated at 84 h. The L-G cows ($n = 226$) received no GnRH and were inseminated at 84 h. Blood samples (BS) were collected on d -17 and -7 from a subset of cows ($n = 434$) at 8 of 12 locations.

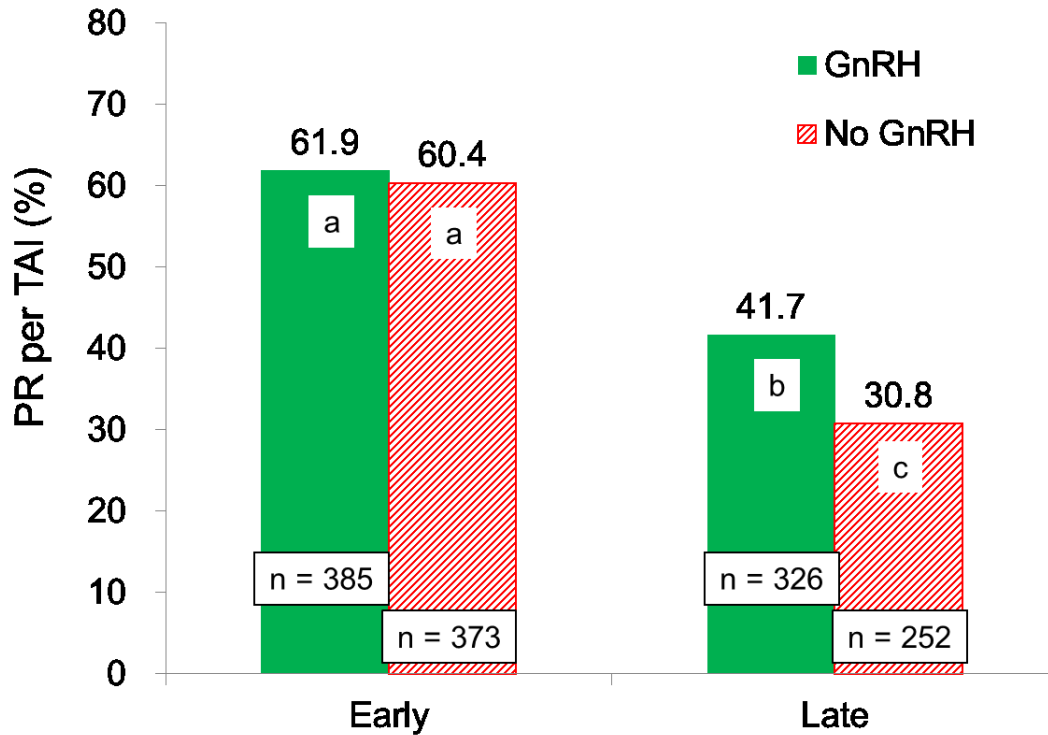

Figure 3.2

Pregnancy risk (PR) per timed AI by treatment. The early cows (E+G, and E-G) were detected in estrus by 65 h, inseminated and either received GnRH at 65 h (E+G) or did not receive GnRH (E-G). The remaining cows were allocated to 2 treatments: 1) injected with GnRH at 65 h and inseminated at 84 h (L+G); or 2) no GnRH at 65 h and inseminated at 84 h (L-G). Bars with different letters differ ($P < 0.05$). Values at the base of each bar represent the number of cows per treatment.

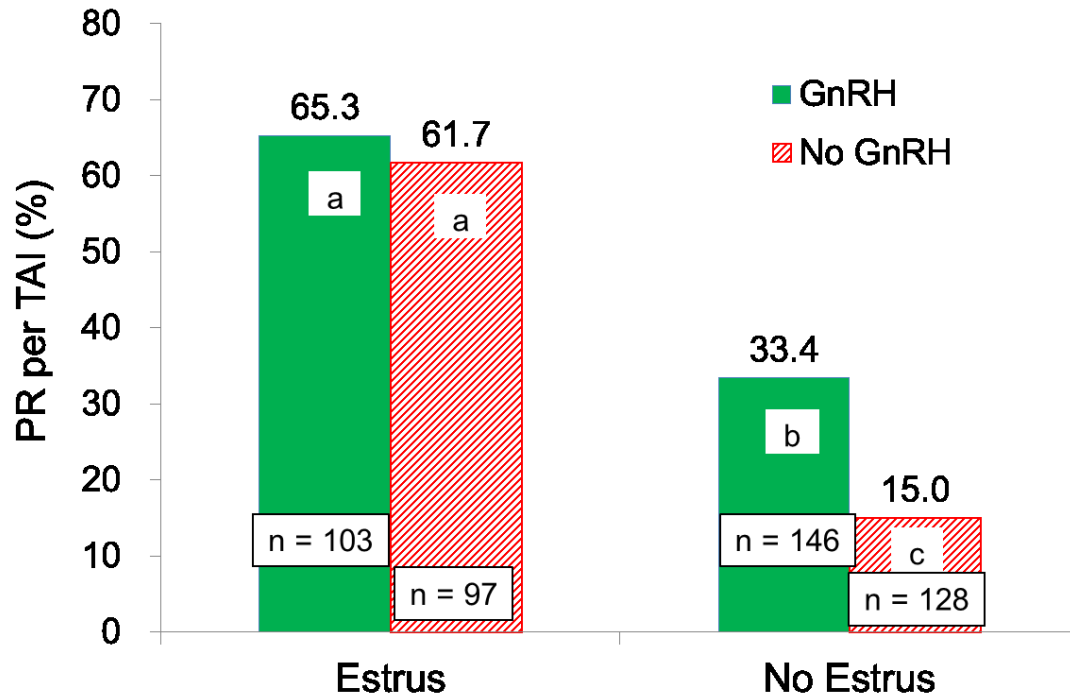

Figure 3.3

Pregnancy risk (PR) per timed AI for cows inseminated at 84 h. Based on whether the estrus-detection patch with > 50 % activated between 65 and 84 h after CIDR insert removal, cows were classified as estrus or no estrus. Bars with different letters differ ($P < 0.05$).

Chapter 4 - Indicators Related to Fertility

INTRODUCTION

Reproduction in mammalian species requires a highly integrated series of controls and feedback loops. Control of reproductive function not only involves feedback from reproductive organs, but also signals indicating the nutritional status of the animal. The study of either nutrition or reproduction without considering their interaction is only valuable for understanding basic concepts. Understanding reproduction from the animal level should include considerations for all factors that may have a significant impact on overall reproductive performance. The significant energetic expenditure necessary to reproduce deems nutritional status to be a key component of successful reproductive performance. Regulation of organ, tissue, and cellular communications in beef cows related to reproductive function arising from nutritional inputs of the animal are somewhat unique considering the metabolic functions of the complex digestive system of a ruminant. Specific partitioning of energy utilization warrants investigation of the signals involved and indicators of that signaling. The control center that is involved not only in the integration of reproductive and digestive organ signals, but also the single gateway through which initiation of reproduction function occurs is the hypothalamus.

HYPOTHALAMUS

Tissues of the hypothalamus synthesize and release peptides and hormones that release hormonal signals from the anterior pituitary that govern various reproduction functions. The portal vascular system is responsible for relaying one of these signals from the hypothalamus in the form of the decapeptide GnRH to the anterior pituitary. GnRH secreting neurons arise in the hypothalamus and the hormone they release is the final common pathway of reproductive control. Reproductive performance is dictated solely by the hypothalamic synthesis and release

of GnRH (Clarke and Cummins, 1982). Immunoreactivity studies have determined that cells which synthesize GnRH are located mainly in two areas of the bovine hypothalamus. The preoptic area (POA) and the organum vasculosum of the lamina terminalis (OVLT) both contain a relative abundance of GnRH soma and fibers (Tanco et al., 2016). The researchers also reported that the abundance of GnRH did not vary depending on the phase of the estrous cycle. This finding collaborates other studies that have concluded that GnRH neurons do not possess steroid hormone receptors (Herbison and Theodosis, 1992; Skinner et al., 2001).

Control of reproductive function is mediated through variations in the amplitude and frequency of GnRH released from the hypothalamus. Gonadotropes in the anterior pituitary are dependent on pulsatile GnRH secretions released by the hypothalamus (Clarke et al., 2011). Luteinizing hormone (LH) is released in correspondence to GnRH pulses; however, there are exceptions. When the frequency of GnRH pulses is reduced and the amplitude of the pulses is held constant the response of LH release is increased. The amplitude of the LH release is limited by the releasable quantity of LH in the anterior pituitary (Clarke and Cummins, 1985). The effect of cortisol on the gonadotropes in the anterior pituitary has been shown to decrease the amplitude of LH pulses in some cases (Breen et al., 2008). Follicle-stimulating hormone (FSH) synthesis is also dependent on GnRH secretion; however, release of FSH is not as closely linked to GnRH as LH. Follicle-stimulating hormone will continue to be released as long as releasable stores are available even if GnRH pulses from the hypothalamus cease (Clarke and Cummins, 1985). Secretions of LH then are more responsive to changes in GnRH pulse generation, whereas FSH is released in a more consistent and non-GnRH dependent manner.

Hypothalamic release of growth-hormone releasing hormone (GHRH), although not directly responsible for gonad activity, is of interest reproductively because of the interaction of

nutrition and reproduction. Growth-hormone releasing hormone, similar to GnRH, is secreted into the portal vascular system where it binds to somatotrophs in the anterior pituitary resulting in growth hormone (GH) release into the circulatory system. Growth hormone is involved in many metabolic processes either directly or through one of its intermediaries, insulin-like growth factor I (Etherton, 2004). Thomas et al. (2009) reported that although serum concentrations of GH were only weakly correlated with GHRH concentrations in the third-ventricle of the hypothalamus, 90% of GH pulses detected in the circulatory system were preceded by a pulse of GHRH. The close proximity and activity of GHRH and GnRH is of interest in the search to determine indicators of metabolic control of reproductive function.

GnRH SECRETAGOGUES

As noted previously, it is not likely that steroid hormone receptors are found in or on GnRH-secreting neurons. Likewise, no receptors have been identified for circulating metabolites on said GnRH secreting neurons. Short and Adams (1988) noted a connection between nutrition and reproductive function nearly 30 y ago; however, the mechanism and specific metabolic messengers or signals are still not fully described. Recent research has identified several links in the pathway before GnRH secretion that furthers the knowledge of nutritional influences.

The family of peptides known as kisspeptins has emerged as central secretagogues that impact GnRH-secreting neurons in the hypothalamus. Kisspeptins are a product of the *Kiss 1* gene and were first discovered as a metastasis-suppressor (Lee et al., 1996). The amino acid sequence of kisspeptins contain an initial common decapeptide with numerous longer peptide chain versions that have specific roles in fish, birds, non-mammalian vertebrates, and mammals (Kotani et al., 2001). Kisspeptin is identified as the most potent factor in GnRH release (Steiner, 2013). Kisspeptin signals through the activation of G protein-activated phospholipase C (PLC β)

when bound to the kisspeptin receptor (Stafford et al., 2002). The PLC β pathway continues with the generates the second messengers, inositol triphosphate (IP₃) and diacylglycerol (DAG), which in turn mediate intracellular Ca²⁺ for the activation of protein kinase C.

Bovine kisspeptin soma and fibers are abundant in both the POA and the arcuate nucleus (ARC); the respective sources of GnRH surges and pulsatile secretions (Tanco et al., 2016). The fibers of kisspeptin cells in the ME of the hypothalamus of horses synapse with GnRH soma and fibers that express kisspeptin receptors (Magee et al., 2009). Cows treated with exogenous injections of kisspeptin at the dosage of 0.1 nmol/kg BW demonstrated a LH release, which supported the role of kisspeptin in GnRH control (Whitlock et al., 2008). Similar responses have been documented in sheep (Smith et al., 2009), goat (Hashizume et al., 2010), pig (Lents et al., 2008), and horses (Magee et al., 2009).

Kisspeptin cells in the ARC are co-expressed with the endogenous opioid dynorphin and neurokinin B (NKB, Wakabayashi et al., 2010). Dynorphin and NKB are inhibitory and stimulatory, respectively, to GnRH release. The neural complex of kisspeptin, NKB, and dynorphin (KNDy) is critical for the pulsatile secretions of GnRH from the ARC (Goodman et al., 2014). Pulses of NKB initiate, whereas dynorphin effectively terminates, each pulse of GnRH. Coupled with kisspeptin this mechanism modulates the frequency and amplitude of pulses of GnRH. Kisspeptin cells in the ovine ARC all have estradiol receptors (ER α) and 90% also have progesterone receptors (Franceschini et al., 2006; Adachi et al., 2007). Presence of these steroid receptors thus facilitates the mechanism for gonadal control of pulsatile GnRH. Tanco et al. (2016) identified an abundance of KNDy neurons in the ARC of bovine, with a greater expression during periestrous than diestrous stages of the estrous cycle. Merkley et al. (2012) suggested that the KNDy complex of neurons modulates the effect of estradiol in the

ARC and also found that kisspeptin neurons in ewes were likely involved in the preovulatory LH surge in both the POA and the ARC.

A fourth peptide, in addition to those produced by KNDy neurons, that has shown to alter GnRH secretion, is RFamide-related peptide-3, which is also known as gonadotropin-inhibitory hormone (GnIH). This GnIH as the name implies has an inhibitory effect on GnRH secretion (Kriegsfeld et al., 2010). These GnIH cells are predominantly located in the dorsomedial hypothalamic nucleus; however the fibers of these cells project into the POA to synapse with GnRH-secreting neurons (Ubuka et al., 2012; Tanco et al., 2016). Kriegsfeld (2010) reported that in hamsters the inhibitory effect of GnIH was a direct action on GnRH neurons. Considering the similar location of soma and fibers in the bovine, it is reasonable to hypothesize a similar mode of action in the cow.

Gonadal feedback to the hypothalamus, both positive and negative, is adequately explained through the KNDy complex and GnIH; however, the influence of circulating metabolites either directly or through signaling hormones still an active area of discovery. A ruminant model using sheep, because of animal size and cost considerations, is more completely understood than the cow. The beef cow that is typically on grazing land and not conducive to intense study is conspicuously understudied. The information that is known about nutritional signaling in the hypothalamus of the cow does correspond with similar studies in sheep; however, understanding of the sheep model is not complete. The seasonal breeding behavior of sheep is an example of differences in reproductive controls between species. It is unknown if nutritional controls exist that are significantly unique to the beef cow.

HYPOTHALAMIC NEUROPEPTIDES

Signaling peptides related to nutritional status to which the hypothalamus is responsive are relevant to the discussion of nutritional impact on reproduction. Neuropeptide Y (NPY), first described by Tatemoto et al. (1981), was reported to be present in the brain. Further research determined that NPY is an orexigen (appetite effector; Clark et al., 1984). When suckled, ovariectomized cows were subjected to treatment with NPY a rapid decrease in LH, and presumably GnRH secretions were noted (Gazal et al., 1998). More recent research in sheep has confirmed that elevated NPY expression reduces LH amplitude; moreover, NPY expression is greater in thinner sheep and decreases as the plane of nutrition improves (Miller et al., 2007). Reduction in NPY expression was accelerated as adiposity increased, when compared with sheep of similar body condition but in a static nutritional plane. This apparent nutritional “memory” indicates that change in body condition over time is more critical to reproductive function than absolute energy reserves at a point in time.

Several neuropeptides have been identified since the discovery of NPY that are both orexigenic and anorexigenic in the way they affect eating behavior. The orexigenic peptide agouti related protein (AgRP) is important because it serves as an intermediary for signaling energy balance with receptors colocalized with NPY. Although AgRP increases appetite, elevated blood non-esterified fatty acids (NEFA) commonly observed in early lactating dairy cows suppresses AgRP (Borner et al., 2013). Cows with elevated AgRP are more efficient in their energy usage. The dependency on stored fat during early lactation and the associated greater NEFA concentration compared with cows in positive energy balance might actually result in reduced energy efficiency and feed intake associated with AgRP suppression. In sheep

studies AbRP has been shown to be a more powerful orexigenic peptide than NPY (Wagner et al., 2004).

The neuropeptide proopiomelanocortin (POMC), in contrast to AgRP and NPY, is anorexigenic (Miller et al., 2007). The hypothalamic GnRH response to POMC, which is actually a complex of interacting peptides, varies depending on cofactors that result in either activation or deactivation of GnRH pulses (Clarke et al., 2014). For example, POMC in the presence of estradiol results in increased activation of GnRH pulses (Conde et al., 2016). In lean sheep the expression of the gene for proconvertase 1 reduces activation and effect of POMC. Kisspeptin also has been shown to reduce the activity of POMC (Daniel et al., 2015). The variable activation of POMC provides a mechanism for a variable GnRH secretion depending on nutritional status.

Increasing nutritional status in ruminants is characterized by an increase in the expression of cocaine- and amphetamine-regulated transcript (CART) genes (Miller et al., 2007). The CART genes have an anorexigenic effect in the animal and also a direct reproductive effect. Studies conducted in cows demonstrate that CART is involved in the process of follicle selection (Folger et al., 2013). The selection process is mediated by CART, which reduces the estrogenic capabilities of subordinate follicles.

PHYSICAL INDICATORS OF NUTRITIONAL STATUS

The concept that reproductive function is influenced by the nutritional status of an animal has been observed for decades (Kennedy, 1953). Short et al. (1990) proposed that energy is partitioned and that, until body fat reserves are satisfied, there is no energy available for reproduction. Short also suggested that BCS would be an accurate indicator of breeding fitness. In support of the positive influence of pre calving BCS on future reproductive performance,

Ayres et al. (2014) reported that Zebu cattle in greater BCS and with greater depth of rump fat (RF) at calving had improved PR in the next breeding season. In contrast, BCS at calving was not related to future reproductive performance in young *Bos taurus* cows grazing in New Mexico (Mullinicks et al., 2012). Roberts (2008) also found that BCS at calving was an inadequate indicator of breeding competence in primiparous beef cows in Montana. In a study that investigated BCS and RF changes during the postpartum period, cows that maintained or gained fat reserves had greater PR than cows that became thinner (Looper et al., 2010). Variability of BCS assignment in conjunction with the inability to detect subtle changes in condition has promoted the search for a more precise measure of energy status. Ultrasound measurements of fat deposition are repeatable among both episodes and technicians (Brethour, 1992). Rump fat measurements procured with ultrasound have the potential to accurately monitor subtle changes in body composition in field conditions (Odhiambo et al., 2009). The change in body composition determined over a period of time postpartum and prior to breeding with a minimum of two observations could more accurately assess breeding fitness than a single subjective BCS.

NUTRITIONAL HORMONES WITH HYPOTHALAMIC ACTIVITY

Insulin

The role of insulin in regulating circulating glucose indicates that insulin should be important in the control of GnRH pulses. In a study to examine insulin effect on ovarian tissue, heifers fed a low-energy diet were infused with insulin via jugular cannula (Harrison and Randel, 1986). Heifers infused with insulin had more corpora lutea (CL) in their ovaries, ovaries of a greater weight, and CL with a greater weight than their non-infused herd mates. In another study that examined gene expression, heifers fed a high-energy diet had greater concentrations of blood insulin and a corresponding lesser expression of NPY and AgRP in the ARC than heifers fed a

low-energy diet (Allen et al., 2012). Presence of insulin receptors in GnRH-secreting neurons seems to identify insulin as a nutritional signal for reproductive performance (Salvi et al., 2006). Insulin administered to sheep via intracerebroventricular cannula stimulated LH secretion in rams, indicating a role for insulin in GnRH release (Miller et al., 1995). The ARC is responsive to insulin and greater insulin concentrations associated with greater circulating glucose concentrations is indicative of improved reproductive function when compared with diminished insulin concentrations.

Leptin

The role of leptin in controlling the release of GnRH has been researched in a large number of studies. Leptin is secreted by adipocytes and other tissues that have lipogenic-lipolytic capabilities (Keisler et al., 1999). In the ruminant, glucose is tightly regulated by insulin. Anabolism and catabolism of adipose tissue become important indicators of nutritional status. Serum concentrations of leptin are positively correlated with percentage of body fat. When cows were fasted for 60 h, glucose and LH release were not affected; however, leptin and insulin concentrations were attenuated (Amstalden et al., 2002). Intracerebroventricular delivery of leptin restored leptin and insulin concentrations, and also increased the concentration and pulse amplitude of LH. This finding indicates that greater leptin concentration has a positive and rapid influence on the ARC. Keisler et al. (1999) reported that feed-restricted ewes had increased abundance of hypothalamic leptin receptors compared with well-fed ewes. The rapid change in LH release reported by Amstalden et al. (2002) may have been due to the colonization of leptin receptors during limit feeding.

Insulin-like Growth Factor-1

The liver is the primary synthesis site of a 70 amino acid chain that is known as insulin-like growth factor 1 (IGF1); it has a close relationship with insulin. Cows in a positive energy balance have a positive relationship between GH and IGF-1; however, when nutrients are restricted, the relationship between GH and IGF-1 is reversed (Flores et al., 2008). Cows that were energy restricted postpartum did not resume estrus and had lesser circulating IGF-1 but greater GH concentrations than contemporary cows that did resume estrus (Roberts et al., 1997). In the same study, cows that were not energy restricted had similar concentrations of GH and IGF-1 regardless of estrus-cycle status. Furthermore, beef heifers fed a restricted energy diet had decreased concentrations of blood IGF-1 and normal GH (Armstrong et al., 1993). Dairy cows treated with exogenous GH had an increase in circulating IGF-1 concentrations when compared with untreated cows; however their plane of nutrition was not restricted (Bilby et al., 1999). The correlation between IGF-1 and estrus-cycle status could enable researchers to use IGF-1 concentrations as a breeding fitness indicator.

Supporting IGF-1 concentration as a breeding fitness indicator is an experiment incorporating high-linoleate safflower in a beef cow diet (Scholljegerdes et al., 2009). Supplemented cows were less fertile even though the energy content of their diet was greater than non-supplemented cows. The linoleate supplement had a negative effect on IGF-1 concentrations. Flores et al. (2008) also reported that pre ovulatory follicular diameter was greater in suckled beef cows with greater IGF-1 concentrations than their herd mates with lesser IGF-1. Based on results in another study, Funston et al. (1996) proposed that IGF-1 was critical to oocyte maturation and ovulation. When GH was decreased via immunization against GHRH, IGF-1 concentrations were lesser, puberty was delayed in heifers, and the number of follicles

present on ovaries was reduced (Armstrong and Benoit, 1996). The presence of circulating IGF-1 in sufficient quantity appears to be critical for fertility in beef cattle.

SELECTED METABOLITES AND RELATED REPRODUCTIVE FUNCTION

The previous sections have detailed how several circulating metabolites and hormones are associated with reproductive performance in beef cows. It is difficult and expensive to assay these indicators, so efforts are being made to find more easily-assayed indicators to predict reproductive performance. In this section, commonly assayed indicators will be examined to see if they accurately and easily describe physiological events that are important for reproductive success. Actual nutrients used in cell metabolism or by products of metabolic processes should be found in proportional amounts in the animal's circulatory system. Negative energy balance (NEB) represents the quantity of energy in the diet that is lacking to meet the maintenance and production needs of a cow (Drackley and Cardoso, 2014). Incidence of NEB in dairy cows is associated with more days postpartum to first estrus, reduced oocyte quality, impaired conception to AI, and delayed time to conception. Energy balance is nearly impossible to quantify in grazing beef cows; however, a post calving decrease in BW has been noted (Mulliniks et al., 2011). Identifying specific profiles of circulating metabolites may be helpful in understanding the extent and duration of NEB in beef cows.

β -hydroxybutyrate

The nutritional physiology of a postpartum lactating cow is characterized by NEB because energy requirements needed to support maintenance, growth (immature cows), and lactation exceed energy intake. To compensate for energy shortfalls, lipolysis of adipose tissue is initiated (Bauman and Currie, 1980). Circulating fatty acids in the non-esterified form (NEFA)

are utilized by the liver to provide glucose for milk production and other carbon structures to support body functions (Hegardt, 1999). The products of hepatic fat metabolism include β -hydroxybutyrate (BHB) and acetate. When dairy cows had circulating blood concentrations of BHB > 12 mg/dL reproductive traits were reduced (Ospina et al., 2010). In contrast cows with BHB > 10 mg/dL did not have poorer pregnancy risk than cows with BHB < 10 mg/dL (Chapinal et al., 2012). In both of the latter studies, greater BHB concentrations were associated with metabolic disease and decreased milk production. Mulliniks et al. (2013) analyzed the calving dates of young suckled beef cows in light of their serum BHB concentrations assessed during the previous year. In year 1 of the experiment, BHB was indicative of future calving when sampled at the time of breeding. In the next year of the study, BHB only had predictive power when considering a pre-calving concentration in second-parity cows. The underlying physiology and the equivocal results indicate that the value of BHB concentrations as a reproductive predictor should be examined further.

Blood Urea Nitrogen

The correct quantity and type of amino acids are necessary for cellular growth and function. Adequate protein is important in reproductive function of animals. The ruminant's requirements for protein are generally focused on quantity rather than type because of the rumen's ability to produce microbial protein. Some protein is not digested in the rumen (RUP) and is bypassed directly to the abomasum. Excess dietary protein in the cow is reduced to ammonia in the rumen and is converted to urea in the liver (Rajala-Schultz et al., 2001). Protein that is not converted to ammonia in the rumen does not contribute to blood urea nitrogen (BUN). The practice of feeding corn byproducts has increased the amount of RUP available to beef cows when supplementation is implemented (Wilson et al., 2015). Circulating concentrations of BUN

have been used as an indicator of the protein status of grazing beef cows; however, if RUP is incorporated into the diet, BUN assays may not reflect overall protein intake. Cows fed isocaloric and isonitrogenous diets with increasing amounts of RUP had similar reproductive performance (Wilson et al., 2015). In a large study of dairy cows, Rajala-Schultz (2001) reported that dairy cows with greater concentrations of circulating urea had poorer fertility than cows with lesser urea. In contrast, BUN concentration did not impact fertility in lactating dairy sheep (Karen et al., 2011). When cows were fed a diet with elevated RUP during gestation they were reported to have lower BUN and lighter birth weight calves than cows fed a diet with elevated rumen-degraded protein (RDP); however, dystocia and subsequent reproductive performance did not differ (Radunz et al., 2010). In another study, pregnancy risk was not dependent on BUN concentrations in primiparous cows (Wiley et al., 1991). In a study conducted in Africa, Bonsmara heifers on a protein-rich diet had poorer pregnancy risk than heifers consuming lesser protein (Tshuma et al., 2014). Elevated BUN concentration has been associated with earlier puberty (Cappelozza et al., 2014), but impaired oocyte competence in beef heifers (Sinclair et al., 2000). The impact of protein quantity in the diet is inconclusive when the pregnancy risk of beef cows is considered. There seems to be lower and upper thresholds where reproductive performance is compromised, which are largely undefined in beef cows.

Glucose

In the ruminant animal, volatile fatty acids are the primary energy sources for most bodily functions. Milk synthesis in the lactating female, however, is dependent on glucose availability. Reproductive tissues including oocyte development also require glucose (Berlinger et al., 2012). A decrease in circulating glucose in early postpartum dairy cows indicates a partitioning priority that favors lactation over reproduction (Lucy et al., 2013). Although beef

cows do not produce the same quantity of milk as dairy cows, the partitioning priorities are likely similar. When Lucy et al. (2013) infused glucose in stepwise, increasing fashion; they determined a physiological upper limit which was accompanied by rapid decreases in NEFA and BHB concentrations. In another study, Garverick et al. (2013) reported that plasma glucose concentration on d 3 postpartum was indicative of reproductive success at the first insemination after calving in lactating dairy cows. Glucose is likely more sensitive to nutritional status than measures of stored energy such as BCS. When beef cows in either a BCS of 4 or 6 were sampled for glucose concentration after calving no difference was detected between BCS 4 or 6 (Lake et al., 2006). Contrary to the report in dairy cows (Garverick et al., 2013), Mullinicks et al. (2013) reported that beef cows with greater circulating glucose concentration were less likely to become pregnant early in the breeding season. The samples in Mullinicks et al. (2013) were collected during the 60 d before calving compared with d 3 postpartum in the dairy-cow study (Garverick et al., 2013). Temporal differences in glucose concentration, dependent on the time of collection relative to feeding also have been noted (Lake et al. 2006). Daily variations in glucose concentrations make accurate assessment of glucose difficult. In addition, rapid changes in glucose concentration after feeding and other physiological events complicate accurate assessment of glucose status. Nevertheless, the predictive power of glucose on reproductive success warrants further examination.

Non-Esterified Fatty Acids

Ruminants including beef cows use propionate and acetate as their primary energy source (Harmon, 1992). During periods when digested energy supply is inadequate to meet the cow's nutritional requirements, such as during lactation, stored lipids are mobilized in the form of non-esterified fatty acids (NEFA) for conversion to energy. In dairy cows where NEB is easier to

quantify than in beef cows, early lactation was associated with decreased concentrations of glucose and insulin coupled with increased concentrations of NEFA (Overton and Waldron, 2004). Similarly, Lake et al. (2006) reported an inverse relationship between insulin and NEFA in conjunction with increased NEFA concentration in postpartum beef cows. Beef heifers infused with VFA responded with greater insulin and lesser NEFA concentration (DiConstanzo et al., 1999). A study conducted using dairy cows also indicated that cows with NEFA concentration above 0.60 mEq/L were likely to have lesser PR and milk yield (Ospina et al., 2010). A larger more geographically diverse study, in contrast, only detected an impact on milk yields and not PR in postpartum dairy cows with greater concentration of NEFA (Chapinal et al., 2012). Primiparous beef cows with greater concentration of NEFA before calving had longer intervals of postpartum anestrus than primiparous cows with lesser NEFA concentration (Guedon et al., 1999). Circulating concentrations of NEFA is an accurate indicator of energy balance in cows and may be indicative of reproductive success (Gross et al., 2011).

HYPOTHESIS

Assays for circulating metabolites are readily available and relatively inexpensive. The metabolites BHB, BUN, glucose, and NEFA correspond with systemic changes in energy and protein status. In contrast, body condition score was not a strong indicator of pregnancy success in young beef cows (Mullinicks et al., 2012). Nutritional status of cows before the breeding season was associated with differences in PR (Ciccioli et al., 2003). Individual nutritional measures at a specific time may be indicative of PR; however, multiple measures over several wk could provide greater predictive power for future reproductive success. We hypothesize that nutritional indicators assessed during the several wk before the breeding season will differ

among cows that become pregnant to timed AI compared with those cows that fail to conceive to AI.

LITERATURE CITED

- Adachi, S., S. Yamada, Y. Takatsu, H. Matsui, M. Kinoshita, K. Takase, H. Sugiura, T. Ohtaki, H. Matsumoto, Y. Uenoyama, H. Tsukamura, K. Inoue, and K-I Maeda. 2007. Involvement of anteroventral periventricular metastin/kisspeptin neurons in estrogen positive feedback action on luteinizing hormone release in female rats. *J. Reprod. Devel.* 53:367–378.
- Allen, C. C., B. R. Alves, X. Li, L. O. Tedeschi, H. Zhou, J. C. Paschal, P. K. Riggs, U. M. Braga-Neto, D. H. Keisler, G. L. Williams, and M. Amstalden. 2012. Gene expression in the arcuate nucleus of heifers is affected by controlled intake of high- and low-concentrate diets. *J. Anim. Sci.* 90:2222–2232. doi:10.2527/jas.2011–4684.
- Amstalden, M., M. R. Garcia, R. L. Stanko, S. E. Nizielski, C. D. Morrison, D. H. Keisler, and G. L. Williams. 2002. Central infusion of recombinant ovine leptin normalizes plasma insulin and stimulates a novel hypersecretion of luteinizing hormone after short-term fasting in mature beef cows. *Biol. Reprod.* 66:1555–1561.
- Armstrong, J. D., W. S. Cohick, R. W. Harvey, E. P. Heimer, and R. M. Campbell. 1993. Effect of feed restriction on serum somatotropin, insulin-like growth factor-I (IGF-I) and IGF binding proteins in cyclic heifers actively immunized against growth hormone releasing factor. *Domest. Anim. Endocrinol.* 10:315–324.
- Armstrong, J. D., and A. M. Benoit. 1996. Paracrine, autocrine, and endocrine factors that mediate the influence of nutrition on reproduction in cattle and swine: an in vivo, IGF-1 perspective. *J. Anim. Sci.* 74(Suppl. 3):18–35.

- Ayres, H., R. M. Ferreira, J. R. Torres-Junior, C. G. Demetrio, M. F. Sa Filho, L. U. Gimenes, L. Penteado, M. J. D'Occhio, and P. S. Baruselli. 2014. Inferences of body energy reserves on conception rate of suckled zebu beef cows subjected to timed artificial insemination followed by natural mating. *Theriogenology* 82:529-536. doi:10.1016/j.theriogenology.2014.04.026.
- Bauman, D. E., and W. B. Currie. 1980. Partitioning of nutrients during pregnancy and lactation: A review of mechanisms involving homeostasis and homeorhesis. *J. Dairy Sci.* 63:1514-1529.
- Berlinguer, F., A. Gonzalez-Bulnes, I. Contreras-Solis, A. Spezzigu, L. Torres-Rovira, S. Succu, S. Naitana, and G. G. Leoni. 2012. Glucogenic supply increases oocyte developmental competence in sheep. *Reprod. Fertil.* 24:1055–1062.
- Bilby, C. R., J. F. Bader, B. E. Salfen, R. S. Youngquist, C. N. Murphy, H. A. Garverick, B. A. Crooker, and M. C. Lucy. 1999. Plasma GH, IGF-I, and conception rate in cattle treated with low doses of recombinant bovine GH. *Theriogenology* 51:1285–1296. doi:S0093–691X(99)00072–2.
- Brethour, J. R. 1992. The repeatability and accuracy of ultrasound in measuring back fat of cattle. *J. Anim. Sci.* 70:1039–1044.
- Börner, S., E. Albrecht, C. Schäff, S. Hacke, Ulrike Kautzscha, M. Derno, H. M. Hammon, M. Röntgen, H. Sauerwein, and B. Kuhla. 2013. Reduced AgRP activation in the hypothalamus of cows with high extent of fat mobilization after parturition. *Gen. Comp. Endocrinol.* 193:167-77. doi:10.1016/j.ygcen.2013.08.002.

- Cappellozza, B. I., R. F. Cooke, M. M. Reis, P. Moriel, D. H. Keisler, and D. W. Bohnert. 2014. Supplementation based on protein or energy ingredients to beef cattle consuming low-quality cool-season forages: II. performance, reproductive, and metabolic responses of replacement heifers. *J. Anim. Sci.* 92:2725–2734. doi:10.2527/jas.2013–7442.
- Chapinal, N., M. E. Carson, S. J. LeBlanc, K. E. Leslie, S. Godden, M. Capel, J. E. Santos, M. W. Overton, and T. F. Duffield. 2012. The association of serum metabolites in the transition period with milk production and early-lactation reproductive performance. *J. Dairy Sci.* 95:1301–1309. doi:10.3168/jds.2011–4724.
- Ciccioli, N. H., R. P. Wettemann, L. J. Spicer, C. A. Lents, F. J. White, and D. H. Keisler. 2003. Influence of body condition at calving and postpartum nutrition on endocrine function and reproductive performance of primiparous beef cows. *J. Anim. Sci.* 81:3107–3120.
- Clark, J. T., P. S. Kalra, W. R. Crowley, and S. P. Kalra. 1984. Neuropeptide Y and human pancreatic polypeptide stimulate feeding behavior in rats. *Endocrinology* 115:427–429.
- Clarke, I. J., K. J. Burman, B. W. Doughton, and J. T. Cummins. 1986. Effects of constant infusion of gonadotrophin-releasing hormone in ovariectomized ewes with hypothalamo-pituitary disconnection: Further evidence for differential control of LH and FSH secretion and the lack of a priming effect. *J. Endocrinol.* 111:43–49.
- Clarke, I. J., R. Campbell, J. T. Smith, and S. Wray. 2011. Neuroendocrine control of reproduction. In: Fink, G., D. P., Levine, J. (Eds), *Handbook of Neuroendocrinology*. Elsevier, pp. 198–235.

- Clarke, I.J., and J. T. Cummins, 1982. The temporal relationship between gonadotropin releasing hormone (GnRH) and luteinizing hormone (LH) secretion in ovariectomized ewes. *Endocrinology* 111:1737–1739.
- Clarke, I. J., and J. T. Cummins. 1985. GnRH pulse frequency determines LH pulse amplitude by altering the amount of releasable LH in the pituitary glands of ewes. *J. Reprod. Fertil.* 73:425–431.
- Conde K., C. Meza, M. J. Kelly, K. Sinchak, and E. J. Wagner. 2016. Estradiol rapidly attenuates ORL-1 receptor-mediated inhibition of proopiomelanocortin neurons via Gq-coupled, membrane-initiated signaling. *Neuroendocrinology* 2016 Jan 16. [Epub ahead of print]
- Daniel, J. A., C. D. Foradon, B. K. Whitlock, and J. L. Sartin. 2015. Reproduction and beyond, kisspeptin in ruminants. *J. Anim. Sci. Biotech.* 6:23–28. doi:10.1186/s40104-015-0021-4.
- DiCostanzo, A., J. E. Williams, and D. H. Keisler. 1999. Effects of short- or long-term infusions of acetate or propionate on luteinizing hormone, insulin, and metabolite concentrations in beef heifers. *J. Anim. Sci.* 77:3050–3056.
- Drackley, J. K., and F. C. Cardoso. 2014. Prepartum and postpartum nutritional management to optimize fertility in high-yielding dairy cows in confined TMR systems. *Animal* 8 Suppl 1:5–14. doi:10.1017/S1751731114000731.
- Etherton, T. D. 2004. Somatotrophic function: The somatomedin hypothesis revisited. *J. Anim. Sci. (E suppl)* 82:239–244.

- Flores, R., M. L. Looper, R. W. Rorie, D. M. Hallford, and C. F. Rosenkrans Jr. 2008. Endocrine factors and ovarian follicles are influenced by body condition and somatotropin in postpartum beef cows. *J. Anim. Sci.* 86:1335–1344. doi:10.2527/jas.2007–0574.
- Folger, J. K., F. Jimenez-Krassel, J. J. Ireland, L. Lv, and G. W. Smith. 2013. Regulation of granulosa cell cocaine and amphetamine regulated transcript (CART) binding and effect of CART signaling inhibitor on granulosa cell estradiol production during dominant follicle selection in cattle. *Biol. Reprod.* 137:1–8. doi:10.1095/biolreprod.113.111609.
- Franceschini, I., D. Lomet, M. Cateau, G. Delsol, Y. Tillet, and A. Caraty. 2006. Kisspeptin immunoreactive cells of the ovine preoptic area and arcuate nucleus co-express estrogen receptor alpha. *Neurosci. Letters* 401:225–230.
- Funston, R. N., G. E. Seidel Jr, J. Klindt, and A. J. Roberts. 1996. Insulin-like growth factor I and insulin-like growth factor-binding proteins in bovine serum and follicular fluid before and after the preovulatory surge of luteinizing hormone. *Biol. Reprod.* 55:1390–1396.
- Garverick, H. A., M. N. Harris, R. Vogel-Blue, J. D. Sampson, J. Bader, W. R. Lamberson, J. N. Spain, M. C. Lucy, and R. S. Youngquist. 2013. Concentrations of nonesterified fatty acids and glucose in blood of periparturient dairy cows are indicative of pregnancy success at first insemination. *J. Dairy Sci.* 96:181–188. doi:10.3168/jds.2012–5619.
- Gazal, O. S., L. S. Leshin, R. L. Stanko, M. G. Thomas, D. H. Keisler, L. L. Anderson, and G. L. Williams. 1998. Gonadotropin-releasing hormone secretion into third-ventricle cerebrospinal fluid of cattle: Correspondence with the tonic and surge release of

- luteinizing hormone and its tonic inhibition by suckling and neuropeptide Y. *Biol. Reprod.* 59:676–683. doi:10.1095/biolreprod59.3.676.
- Goodman, R. L., L. M. Coolen, M. N. Lehman. 2014. A role for neurokinin B in pulsatile GnRH secretion in the ewe. *Neuroendocrinology* 99:18–32. doi:10.1159/000355285.
- Gross, J., H. A. van Dorland, R. M. Bruckmaier, and F. J. Schwarz. 2011. Performance and metabolic profile of dairy cows during a lactational and deliberately induced negative energy balance with subsequent realimentation. *J. Dairy Sci.* 94:1820—1830. doi:10.3168/jds.2010-3707.
- Guedon, L., J. Saumande, and B. Desbals. 1999. Relationships between calf birth weight, prepartum concentrations of plasma energy metabolites and resumption of ovulation postpartum in Limousine suckled beef cows. *Theriogenology* 52:779–789.
- Harmon, D. L. 1992. Impact of nutrition on pancreatic exocrine and endocrine secretion in ruminants: A review. *J. Anim. Sci.* 70:1290–1301.
- Harrison, L. M., and R. D. Randel. 1986. Influence of insulin and energy intake on ovulation rate, luteinizing hormone and progesterone in beef heifers. *J. Anim. Sci.* 63:1228–1235.
- Hashizume, T., H. Saito, T. Sawada, T. Yaegashi, A. A. Ezzat, K. Sawai, and T. Yamashita. 2010. Characteristics of stimulation of gonadotropin secretion by kisspeptin-10 in female goats. *Anim. Reprod. Sci.* 118:37–41.
- Hegardt, F. G. 1999. Mitochondrial 3-hydroxy-3-methylglutaryl-CoA synthase: A control enzyme in ketogenesis. *Biochem. J.* 338 (Pt 3):569–582.

- Herbison, A. E., and D. T. Theodosis. 1992. Localization of oestrogen receptors in preoptic neurons containing neurotensin but not tyrosine hydroxylase, cholecystokinin or luteinizing hormone-releasing hormone in the male and female rat. *Neuroscience* 50:283–298 doi 10.1016/0306–4522(92)90423–Y.
- Karen, A. M., P. Kovacs, J. F. Beckers, N. M. de Sousa, and O. Szenci. 2011. Plasma urea nitrogen in relation to pregnancy rate in dairy sheep. *Anim. Reprod. Sci.* 124:69–72. doi:10.1016/j.anireprosci.2011.01.012.
- Keisler, D. H., J. A. Daniel, and C. D. Morrison. 1999. The role of leptin in nutritional status and reproductive function. *J. Reprod. Fertil. Supp.* 54:425–435.
- Kennedy, G. C. 1953. The role of depot fat in the hypothalamic control of food intake in the rat. *Proceedings of the Royal Society of Medicine.* 140:578-592.
- Kotani, M., M. Detheux, A. Vandenbogaerde, D. Communi, J. M. Vanderwinden, E. Le Poul, S. Brézillon, R. Tyldesley, N. Suarez-Huerta, F. Vandeput, C. Blanpain, S. N. Schiffmann, G. Vassart, and M. Parmentier. 2001. The metastasis suppressor gene KiSS-1 encodes kisspeptins, the natural ligands of the orphan G protein-coupled receptor GPR54. *J. Biol. Chem.* 276:34631–34636.
- Kriegsfeld, L. J., E. M. Gibson, W. P. Williams 3rd, S. Zhao, A. O. Mason, G. E. Bentley, and K. Tsutsui. 2010. The roles of RFamide-related peptide-3 in mammalian reproductive function and behaviour. *J. Neuroendocrinol.* 22:692–700. doi:10.1111/j.1365–2826.2010.02031.x.

- Lake, S. L., E. J. Scholljegerdes, D. M. Hallford, G. E. Moss, D. C. Rule, and B. W. Hess. 2006. Effects of body condition score at parturition and postpartum supplemental fat on metabolite and hormone concentrations of beef cows and their suckling calves. *J. Anim. Sci.* 84:1038–1047. doi:84/4/1038.
- Lee, J. H., M. E. Miele, D. J. Hicks, K. K. Phillips, J. M. Trent, B. E. Weissman, and D. R. Welch. 1996. KiSS-1, a novel human malignant melanoma metastasis-suppressor gene. *J. Natl. Cancer Inst.* 88:1731–1737.
- Lents C. A., N. L. Heidorn, C. R. Barb, and J. J. Ford. 2008. Central and peripheral administration of kisspeptin activates gonadotropin but not somatotropin secretion in prepubertal gilts. *Reproduction* 135:879–887.
- Looper, M. L., S. T. Reiter, B. C. Williamson, M. A. Sales, D. M. Hallford, and C. F. Rosenkrans Jr. 2010. Effects of body condition on measures of intramuscular and rump fat, endocrine factors, and calving rate of beef cows grazing common bermudagrass or endophyte-infected tall fescue. *J. Anim. Sci.* 88: 4133-4141. doi: 10.2527/jas.2010-3192.
- Lucy, M. C., R. C. Escalante, D. H. Keisler, W. R. Lamberson, and D. J. Mathew. 2013. Short communication: Glucose infusion into early postpartum cows defines an upper physiological set point for blood glucose and causes rapid and reversible changes in blood hormones and metabolites. *J. Dairy Sci.* 96:5762–5768. doi:10.3168/jds.2013–6794.
- Magee, C. C. D. Foradori, J. E. Bruemmer, J. A. Arreguin-Arevalo, P. M. McCue, R. J. Handa, E. L. Squires, and C. M. Clay. 2009. Biological and anatomical evidence for kisspeptin

- regulation of the hypothalamic-pituitary-gonadal axis of estrous horse mares. *Endocrinology* 150:2813–2821. doi:10.1210/en.2008–1698.
- Merkley, C. M., K. L. Porter, L. M. Coolen, S. M. Hileman, H. J. Billings, S. Drews, R. L. Goodman, and M. N. Lehman. 2012. KNDy (kisspeptin/neurokinin B/dynorphin) neurons are activated during both pulsatile and surge secretion of LH in the ewe. *Endocrinology* 153:5406–5414. doi: 10.1210/en.2012-1357.
- Miller, D. W., D. Blache, and G. B. Martin. 1995. The role of intracerebral insulin in the effect of nutrition on gonadotrophin secretion in mature male sheep. *J. Endocrinol.* 147:321–329.
- Miller, D. W., J. L. Harrison, E. J. Bennett, P. A. Findlay, and C. L. Adam. 2007. Nutritional influences on reproductive neuroendocrine output: insulin, leptin, and orexigenic neuropeptide signaling in the ovine hypothalamus. *Endocrinology*. 148:5313–5322. doi:10.1210/en.2007–0534.
- Mulliniks, J. T., S. H. Cox, M. E. Kemp, R. L. Endecott, R. C. Waterman, D. M. Vanleeuwen, and M. K. Petersen. 2012. Relationship between body condition score at calving and reproductive performance in young postpartum cows grazing native range. *J. Anim. Sci.* 90:2811–2817. doi:10.2527/jas.2011–4189.
- Mulliniks, J. T., M. E. Kemp, S. H. Cox, D. E. Hawkins, A. F. Cibils, D. M. Vanleeuwen, and M. K. Petersen. 2011. The effect of increasing amount of glucogenic precursors on reproductive performance in young postpartum range cows. *J. Anim. Sci.* 89:2932–2943. doi:10.2527/jas.2010–3198.

- Mulliniks, J. T., M. E. Kemp, R. L. Endecott, S. H. Cox, A. J. Roberts, R. C. Waterman, T. W. Geary, E. J. Scholljegerdes, and M. K. Petersen. 2013. Does beta-hydroxybutyrate concentration influence conception date in young postpartum range beef cows? *J. Anim. Sci.* 91:2902–2909. doi:10.2527/jas.2012–6029.
- Odhiambo, J. F., J. D. Rhinehart, R. Helmondollar, J. Y. Pritchard, P. I. Osborne, E. E. Felton, and R. A. Dailey. 2009. Effect of weaning regimen on energy profiles and reproductive performance of beef cows. *J. Anim. Sci.* 87: 2428-2436. doi: 10.2527/jas.2008-1138.
- Ospina, P. A., D. V. Nydam, T. Stokol, and T. R. Overton. 2010. Evaluation of nonesterified fatty acids and beta-hydroxybutyrate in transition dairy cattle in the northeastern united states: Critical thresholds for prediction of clinical diseases. *J. Dairy Sci.* 93:546–554. doi:10.3168/jds.2009–2277.
- Overton, T. R., and M. R. Waldron. 2004. Nutritional management of transition dairy cows: Strategies to optimize metabolic health. *J. Dairy Sci.* 87(E. Suppl.):E105–119.
- Radunz, A. E., F. L. Fluharty, M. L. Day, H. N. Zerby, and S. C. Loerch. 2010. Prepartum dietary energy source fed to beef cows: I. effects on pre- and postpartum cow performance. *J. Anim. Sci.* 88:2717–2728. doi:10.2527/jas.2009–2744.
- Rajala-Schultz, P. J., W. J. A. Saville, G. S. Frazer, and T. E. Wittum. 2001. Association between milk urea nitrogen and fertility in Ohio dairy cows. *J. Dairy Sci.* 84:482–489.
- Roberts, A. J. 2008. Assessment of insulin-like growth factor-1 as an indicator of competence for rebreeding in first calf heifers. *Proc. West. Sec. Am. Sci.* 59:257-260.

- Roberts, A. J., R. A. Nugent 3rd, J. Klindt, and T. G. Jenkins. 1997. Circulating insulin-like growth factor I, insulin-like growth factor binding proteins, growth hormone, and resumption of estrus in postpartum cows subjected to dietary energy restriction. *J. Anim. Sci.* 75:1909–1917.
- Salvi, R., E. Castillo, M. J. Voirol, M. Glauser, J. P. Rey, R. C. Gaillard, P. Vollenweider, and F. P. Pralong. 2006. Gonadotropin-releasing hormone-expressing neurons immortalized conditionally are activated by insulin: Implication of the mitogen-activated protein kinase pathway. *Endocrinology* 147:816–826. doi:en.2005–0728.
- Scholljegerdes, E. J., B. W. Hess, M. H. Grant, S. L. Lake, B. M. Alexander, T. R. Weston, D. L. Hixon, E. A. Van Kirk, and G. E. Moss. 2009. Effects of feeding high-linoleate safflower seeds on postpartum reproduction in beef cows. *J. Anim. Sci.* 87:2985–2995. doi:10.2527/jas.2008-1424.
- Short, R.E., and D.C. Adams. 1988. Nutritional and hormonal interrelationships in beef cattle reproduction. *Can. J. Anim. Sci.* 68:29–39.
- Short, R. E., R. A. Bellows, R. B. Staigmiller, J. G. Berardinelli, and E. E. Custer. 1990. Physiological mechanisms controlling anestrus and infertility in postpartum beef cattle. *J. Anim. Sci.* 68:799-816.
- Sinclair, K. D., M. Kuran, F. E. Gebbie, R. Webb, and T. G. McEvoy. 2000. Nitrogen metabolism and fertility in cattle: II. Development of oocytes recovered from heifers offered diets differing in their rate of nitrogen release in the rumen. *J. Anim. Sci.* 78:2670–2680.

- Skinner, D. C., A. Caraty, and R. Allingham. 2001. Unmasking the progesterone receptor in the preoptic area and hypothalamus of the ewe: No colocalization with gonadotropin releasing neurons. *Endocrinology* 142:573–579. doi:10.1210/endo.142.2.7956.
- Smith, J. T., S. N. H. Saleh, and I. J. Clarke. 2009. Seasonal and cyclical change in the luteinizing hormone response to kisspeptin in the ewe. *Neuroendocrinology* 90:283–291.
- Stafford, L. J., C. Xia, W. Ma, Y. Cai, and M. Liu. 2002. Identification and characterization of mouse metastasis-suppressor KiSS1 and its G-protein-coupled receptor. *Cancer Res.* 62:5399–5404.
- Steiner, R. A. 2013. Kisspeptin: past, present, and prologue. *Adv. Exp. Med. Biol.* 784:3–7. doi:10.1007/978-1-4614-6199-9_1.
- Tanco, V. M., B. K. Whitlock, M. A. Jones, R. R. Wilborn, T. d. Brandebourg, and C. D. Foradori. 2016. Distribution and regulation of gonadotropin-releasing hormone, kisspeptin, RF-amide related peptide-3, and dynorphin in the bovine hypothalamus. *PeerJ*. 2016 Mar 21;4:e1833. doi: 10.7717/peerj.1833. eCollection 2016.
- Tatemoto, K., M. Carlquist, and V. Mutt. 1982. Neuropeptide Y--a novel brain peptide with structural similarities to peptide YY and pancreatic polypeptide. *Nature* 296:659–660.
- Thomas, M. G., M. Amstalden, D. M. Hallford, G. A. Silver, M. D. Garcia, D. H. Keisler, and G. L. Williams. 2009. *Domest. Anim. Endocrinol.* 37:196–205. doi:10.1016/j.domaniend.2009.05.006.

- Tshuma, T., D. E. Holm, G. T. Fosgate, and D. C. Lourens. 2014. Pre-breeding blood urea nitrogen concentration and reproductive performance of Bonsmara heifers within different management systems. *Trop. Anim. Health Prod.* 46:1023–1030. doi:10.1007/s11250-014-0608-3.
- Ubuka, T., Y. L. Son, G. E. Bentley, R. P. Millar, and K. Tsutsui. 2013. Gonadotropin-inhibitory hormone (GnIH), GnIH receptor and cell signaling. *General and Comparative Endocrinology* 190:10–17. doi:10.1016/j.ygcen.2013.02.030.
- Wagner, C. G., C. D. McMahon, D. L. Marks, J. A. Daniel, B. Steele, and J. L. Sartin. 2004. A role for agouti-related protein in appetite regulation in a species with continuous nutrient delivery. *Neuroendocrinology* 30:210–18. doi:10.1159/000082735.
- Wakabayashi, Y., T. Nakada, K. Murata, S. Ohkura, K. Mogi, V. M. Navarro, D. K. Clifton, Y. Mori, H. Tsukamura, K. Maeda, R. A. Steiner, and H. Okamura. 2010. Neurokinin B and dynorphin A in kisspeptin neurons of the arcuate nucleus participate in generation of periodic oscillation of neural activity driving pulsatile gonadotropin releasing hormone secretion in the goat. *J. Neurosci.* 30:3124–3132. doi:10.1523/jneurosci.5848-09.2010.
- Whitlock, B. K., J. A. Daniel, R. R. Wilborn, S. P. Rodning, H. S. Maxwell, B. P. Steele, and J. L. Sartin. 2008. Interaction of estrogen and progesterone on kisspeptin-10-stimulated luteinizing hormone and growth hormone in ovariectomized cows. *Neuroendocrinology* 88:212–215.

Wiley, J. S., M. K. Petersen, R. P. Ansotegui, and R. A. Bellows. 1991. Production from first-calf beef heifers fed a maintenance or low level of prepartum nutrition and ruminally undegradable or degradable protein postpartum. *J. Anim. Sci.* 69:4279–4293.

Wilson, T. B., D. B. Faulkner, and D. W. Shike. 2015. Influence of late gestation dry lot rations differing in protein degradability and fat content on beef cow and subsequent calf performance. *J. Anim. Sci.* 93: 5819-5828. doi: 10.2527/jas.2014-8805.

Chapter 5 - Serum and Plasma Metabolites Related to Pregnancy

Risk

INTRODUCTION

Synchronization of estrus and ovulation in suckled beef cows facilitates the use of timed artificial insemination (TAI) by reducing or eliminating the need for detecting estrus. Pregnancy risk (PR) associated with TAI varies depending on nutritional status, age, BCS, and days postpartum of cows. Measures of other indicators of potential reproductive success would be valuable in formulating management decisions. Nutritional and body condition traits of suckled beef cows are causative factors related to pregnancy outcome after breeding (Short et al., 1988). Metabolites circulating in the blood are likely signals to indicate current nutritional status to hypothalamic control centers. Physical appraisals used in establishing BCS (Bellows et al., 1982) effectively assess adipose tissue stores, but do not indicate current energy partitioning. Although partitioning of energy determines the success of insemination (Short et al., 1990), little information is available to identify the metabolic priority of reproductive processes at a given time in postpartum beef cows.

Plasma glucose is the primary energy source used for brain function and lactation in the ruminant. Plasma glucose is a possible candidate to be a hypothalamic signaling metabolite. Stored adipose tissue is metabolized to produce non-esterified fatty acids (NEFA) and circulating NEFA concentration reportedly has an inverse relationship with PR in dairy cows (Ospina et al., 2010). Beta-hydroxybutyrate (BHB) is a major serum-stable ketone produced by the liver during the process of incomplete fatty acid oxidation. The close relationship between BHB and stored lipid utilization warrants investigation of BHB as a signaling metabolite. Increased postpartum intervals to estrus and ovulation in beef cows have been linked to prepartum NEFA

concentration (Guedon et al., 1999); however, the impact of NEFA concentration at the time of AI has not been reported. Research conducted in dairy cows also has indicated a relationship between excessive blood urea nitrogen (BUN), an indicator of dietary ruminally-degradable protein (RDP), and reduced fertility (Rajala-Schultz et al., 2001). Similar relationships in beef cows have not been reported; however, possible changes in protein availability associated with variable, seasonal dietary conditions warrant investigation of relationships between BUN and PR.

Suckled beef cows grazing native pastures are likely to have variations in blood concentrations of the metabolites glucose, BHB, NEFA, and BUN. Two different experiments were designed to examine possible relationships between PR and concentration patterns of metabolites and other physical traits including BW, BCS, and rump fat.

MATERIALS AND METHODS

Experiment 1

All experimental procedures used were approved by the Kansas State University Animal Care and Use committee (protocol no. 3392). Mixed parity (n = 602) suckled beef cows from 11 locations in Kansas during 2 yr were enrolled. Body condition scores (1 = thin; 9 = very fat; Bellows et al., 1982) were assigned 20 d before TAI (d 0) by a trained evaluator. Characteristics of beef cows enrolled by location including breed, percentage of 2-yr-old cows, days postpartum at AI, and BCS at the onset of the ovulation-synchronization program are summarized (Table 5.1).

Concurrent with BCS assessment, blood samples were collected from all cows via puncture of a caudal blood vessel. Blood for plasma glucose analyses were collected into green-top, 10-mL vacutainers containing 143 units of sodium heparin (Covidien LLC, Mansfield, MA).

Blood tubes were inverted several times after collection, stored on ice, transported to the lab, immediately centrifuged at 1,000 x g, and frozen at -20° C. A second blood sample was collected into red-top 10-mL vacutainers for later analysis of BHB, stored on ice, allowed to clot at 5° C, and centrifuged at 1,000 x g within 24 h to harvest serum. Serum was immediately frozen -20° C for later analysis.

Time of AI was designated as d 0. All cows were treated with a 100 μ g GnRH (2 mL Factrel; Zoetis, Florham Park, NJ) on d -10 , 25 mg PGF_{2 α} (; 5 mL Lutalyse; Zoetis) d -3 , and 100 μ g GnRH on d 0. A new progesterone-impregnated controlled internal drug release (CIDR; Zoetis, Florham Park, NJ) insert containing 1.38 g progesterone was placed per vagina at the time of the first GnRH injection (d -10). On d -3 the CIDR insert was removed and cows were inseminated artificially by trained technicians 66 to 72 h later.

Assays

Serum concentrations of progesterone from blood samples collected from cows on d -20 and -10 , were measured by direct quantitative (non-extracted) RIA using Coat-A-Count progesterone kits (Siemens Medical Solutions Diagnostics, Los Angeles, CA) previously validated for bovine serum (Stevenson et al., 2012). Intra- and inter-assay CV for progesterone was 8.9 and 6.1%, respectively. Assay sensitivity was 14.1 ± 1.6 pg/mL. Progesterone concentrations were categorized as high (≥ 1 ng/ml) or low (all other samples). Cows with a high progesterone status at either d -17 or -7 were defined to have resumed estrous cycles (Table 5.1). All other cows were considered to have been anestrous at the onset of the ovulation-synchronization program.

Glucose was measured in plasma samples by an enzymatic assay using a 96-well plate and an Autokit Glucose (Cat# 439-90901, Wako Chemicals, Richmond, VA). Samples were read in a plate reader at 490 nm.

Concentrations of serum BHB were determined using an enzymatic reactivity assay (Pointe Scientific, Ann Arbor, MI). The color reactivity was measured in a plate reader at 490 nm.

Pregnancy Diagnosis

After the TAI, cows were either observed for estrus and reinseminated or exposed to clean-up bulls no sooner than 10 to 12 d after TAI. At 35 ± 3 d after TAI, pregnancy was confirmed by transrectal ultrasonography (Aloka 500V, 5 MHz transrectal transducer, Wallingford, CT). A positive pregnancy outcome required the presence of an embryo with a heartbeat or, in rare occurrences, presence of a corpus luteum and uterine fluid.

Statistical Analyses

The GLIMMIX procedure (METHOD = LAPLACE; ILINK = LOGIT DIST = BINOMIAL SOLUTION ODDSRATIO in SAS (SAS Inst. Inc., Cary, NC) was applied to the binomial outcome variable PR (assessed at 35 d after AI). The independent variables of BCS, days postpartum at AI, and parity (primiparous vs. multiparous) were included as fixed effects in all models. The median value of BCS (BCS = 5.0) was used to allocate cows into 2 BCS categories (≤ 5.0 vs. > 5.0). The median value of days postpartum (75 d) was used to allocate cows into 2 categories (≤ 75 vs. >75). Concentrations of glucose and BHB on d -10 were tested as continuous fixed effects in the model that examined PR. Significance of fixed effects were tested by the random effect of location within year. Models included interactions of the fixed

effects of parity, BCS, and days postpartum. When no significant ($P > 0.05$) interactions were detected, interactions were eliminated from the final model.

The variable BHB had a significant effect on PR and therefore a substitution method was used to determine the cut point with the greatest impact on PR. The GLIMMIX model for PR with BHB as a fixed effect was subsequently analyzed with BHB concentration as a binomial variable (< 800 vs. ≥ 800 μM).

Effects of BCS, days postpartum, parity, and eventual pregnancy risk on glucose and BHB were examined using the GLM procedure in SAS (SAS Inst. Inc.). Cows were categorized by blood concentrations of BHB and glucose. The initial glucose category (G1) was < 30 mg/dL, and then each subsequent category (G2 to G7) was categorized by 10 mg/dL increments. The greatest concentration category (G8) was for cows with concentration ≥ 90 mg/dL. In a similar manner, sample concentrations were allocated to 7 categories reflecting their BHB concentration. The initial category (B1) for BHB concentration was < 400 μM . Categorical divisions were set at each increment of 100 μM (B2 to B6). The greatest concentration category was for those cows with BHB concentration ≥ 900 μM (B7). The concentration categories for glucose and BHB were used in separate analysis by using the GLM procedure in SAS to examine concentration category effects on PR.

Experiment 2

All experimental procedures used were approved by the Kansas State University Animal Care and Use committee (protocol no. 3392). Multiparous Hereford x Angus crossbred suckled beef cows ($n = 38$) at a single location in Kansas were enrolled in a 12-wk study. Cows grazed native pastures consisting primarily of big bluestem (*Andropogon gerardii*), little bluestem (*Schizachyrium scoparium*), and Indian grass (*Sorghastrum nutans*). During the dormant season

(before study wk 8), cows were supplemented (1 kg·cow/d) with a 16% CP supplement and low quality (CP < 10 %) prairie hay. New growth of native grasses was 7 cm in height at study wk 8 and supplementation was discontinued. An excess of 5 cm rainfall occurred during study wk 9 and pastures conditions were excellent during the remainder of the study. All cows were either postpartum (< 3 wk; n = 21) or prepartum (n = 17) at the onset of the study. Every 7 d during a period of 12 wk (between 0800 and 1100 h) before the initiation of a TAI program (d -10; d 0 = TAI), cows were weighed, assigned a body condition score (Bellows et al., 1982), assessed for rump fat depth via ultrasound (Aloka 500V, 3.5 MHz linear transducer, Wallingford, CT; Odhiambo et al., 2009), and blood samples were collected weekly via puncture of a caudal blood vessel for later concentration analyses of NEFA, BHB, BUN, and progesterone. Blood plasma samples for later glucose analyses were handled as described in experiment 1.

At the conclusion of the sample collection period (d -10), all cows were treated with 100 µg GnRH (2 mL Factrel, Zoetis, Florham Park, NJ) and received per vagina a new controlled internal drug release (CIDR; Zoetis, Florham Park, NJ) insert containing 1.38 g progesterone. Seven d later, CIDR inserts were removed and cows were treated with 25 mg PGF_{2α}. Concurrent with CIDR insert removal, estrus-detection patches (Estroject, Rockway, Inc., Spring Valley, WI) were affixed to the tail head of each cow according to manufacturer's recommendation. Cows were inseminated by a trained technician at either 60 or 75 h after CIDR insert removal. Estrus-detection patches were read to determine if estrus occurred by 60 or 75 h. Estrus was indicated when the patch was more than 50% colored.

Pregnancy Diagnosis

Cows were exposed to cleanup bulls beginning 10 to 12 d after TAI. At 35 ± 3 d after TAI, pregnancy was confirmed as described in experiment 1.

Ovulation

Concentrations of progesterone in serum were measured in weekly blood samples as described in experiment 1. First postpartum ovulation was determined to have occurred during the week before the first weekly blood serum concentration of progesterone was ≥ 1 ng/mL.

Metabolite Assays

Plasma glucose and serum BHB were analyzed as described in experiment 1. Non-esterified fatty acids (NEFA) were quantified in serum samples using an acylation of coenzyme A (Wako Chemicals, Richmond, VA) and the color saturation was read at 490 nm. To determine BUN concentrations, 1-mL serum samples were processed by an AutoAnalyzer III (Seal Analytical Inc., Mequon, Wisconsin). The serum samples for the BUN assay were read at the 520 nm.

Statistical Analyses

Metabolite and physical measures of each cow that potentially could be associated with pregnancy outcome were defined as predictor variables: circulating concentrations of glucose, BHB, BUN, and NEFA, in addition to BCS, BW, and rump fat.

Repeated Measures. Weekly values for each of the predictor variables were analyzed in repeated-measure models using the MIXED procedure in SAS (METHOD = REML) to determine the variables influencing PR. A few missing samples were estimated by interpolation of the sample concentration preceding and following the missing value.

A subset of cows ($n = 10$) with at least 3 measures before and 5 measures after calving were analyzed in separate repeated measures models in procedure MIXED to examine the influence of the predictor variables during the peripartum period on subsequent PR. The model consisted of the fixed effects of cow, cow nested within PR outcome, week, and the interaction of PR with week. Effect of PR was tested by the split-plot error of PR within cow, whereas the effect of week or the interaction of PR by week was tested by the whole-plot (residual) error.

A second subset of 12 postpartum cows was used to determine the influence of predictor variables relative to week of ovulation. A total of 9 weekly measures (4 before the week of ovulation, week of ovulation, and 3 after ovulation) in cows that ovulated before the week of AI were analyzed in a repeated measures model in procedure MIXED. The models were constructed as described previously for the first subset of cows, but in these analyses, data were normalized to the week of first postpartum ovulation.

A third subset of postpartum cows ($n = 34$) having at least 7 measures before the onset of the TAI program were used to determine the association of the predictor variables immediately preceding AI on pregnancy outcome and analyzed as repeat measures in procedure MIXED. Each of the predictor variables was examined according to reproductive statuses: 1) estrus-cycle status before onset of the TAI programs (ovulated or anestrus); and 2) resulting pregnancy status after TAI (pregnant vs. not pregnant [open]). The models were constructed as described previously except that number of days post calving was included as a covariate in the model to account for variations relative to calving and data were normalized to the week of AI. The type of covariance matrix that yielded the smallest Akaike's coefficient was used for the final model.

Multivariate Analysis of Variance. To determine possible correlations among predictor variables, a separate model was constructed using the GLM procedure in SAS with all 7

predictor variables included. The MANOVA option was utilized to determine partial correlations among variables, and the significance of each predictor variable on PR. A separate GLM model was run for each of the 7 wk before the onset of the TAI program. Results for each of the weekly determined correlations and their associated *P*-values were then summarized. The week with the most significant correlation between each pair of variables also was noted.

RESULTS

Experiment 1

Pregnancy Risk. The PR after TAI ranged from 6.9 to 78.9% by location (Table 5.1). The overall PR at 11 locations during 2 yr was 50.2 %. The PR according to glucose category in 602 cows, calculated for every 10 mg/dL increment in glucose concentration, ranged from 35 to 58% (Fig. 5.1). Glucose concentration 10 d before timed AI did not affect (*P* = 0.79) PR when analyzed as a continuous variable. In contrast, increased concentration of BHB tended (*P* = 0.08) to negatively affect PR in a subset of 207 cows. The PR according to BHB category, calculated for every 100 μ M change in BHB concentration, ranged from 9 to 45% (Fig. 5.2).

Cows with BCS ≥ 5 were more likely (*P* < 0.01) to become pregnant than their thinner herd mates (59.0 vs. 35.8%), respectively. The PR in primiparous cows (n = 94) was less (*P* = 0.02) than in older (n = 508) cows (17.0 vs. 56.3 %, respectively). Cows that had resumed estrous cycles (n = 174) before the timed AI program were not (*P* = 0.68) more likely to become pregnant than their anestrous (n = 211) herd mates (51.7 vs. 39.8 %), respectively.

Glucose. Plasma glucose concentration 10 d before AI was less (*P* = 0.01) in cows that were pregnant at 35 d after timed AI than in cows that were not pregnant (52.2 vs. 56.9 mg/dL), respectively. In contrast, glucose concentrations 10 d before AI did not differ (*P* > 0.60) between cows above and below the median days postpartum at AI (≤ 75 vs. > 75), between cows that

were cycling vs. anestrous, or between primiparous and multiparous cows. Cows with BCS ≥ 5 had lesser ($P = 0.001$) plasma glucose than their thinner herd mates (51.1 ± 1.0 vs. 57.9 ± 2.0 mg/dL), respectively. The greatest PR (42%) was associated with cows in the lowest glucose category (G1). The least PR (22%) was associated with cows in the greater glucose concentration categories (Fig. 5.1).

β -Hydroxybutyrate. At 10 d before initiating the TAI program, serum BHB concentration was less ($P = 0.002$) in pregnant cows compared with those diagnosed not pregnant (600 ± 18 vs. 690 ± 14 μ M), respectively. No differences ($P = 0.61$) in serum BHB concentrations were detected between primiparous and multiparous cows or between cows above or below the median of 75 d postpartum ($P = 0.35$). In contrast, cows with a BCS ≥ 5 had greater ($P = 0.002$) serum BHB concentration than thinner cows (680 ± 12 vs. 610 ± 24 μ M), respectively. In a subset of cows ($n = 207$) in which estrus-cycle status was determined, cows that had resumed estrous cycles at the initiation of the timed AI program had lesser ($P < 0.05$) serum concentrations of BHB than cows that were anestrous (668 ± 19 vs. 710 ± 16 μ M), respectively. When cows were categorized by their serum BHB concentration, the greatest PR (45%) was associated with the lowest concentration of BHB and the least PR was associated with the second greatest (10%) and greatest BHB concentration (13%; Fig. 5.2).

Experiment 2

The 38 cows enrolled in the study had an overall first postpartum ovulation risk during the 12 wk study period of 57.9%. The pregnancy risk associated with timed AI determined 35 d after AI was 47.4%.

Measures Normalized to Calving. Measurements were assessed in the first subset of 10 cows (3 pregnant and 7 not pregnant) having complete pre- and post-calving data. Changes in

weekly patterns of BCS (Fig 5.3), BHB (Fig. 5.4), BUN (Fig. 5.5) and BW (Fig 5.6) during the peripartum period were not associated with future pregnancy outcome to AI despite weekly mean differences ($P < 0.05$) in BW and BCS. Decreasing mean BW at calving resulted from loss of weight associated with the calf, placental tissue and fluids.

In contrast, cows that later became pregnant to AI had less ($P = 0.02$) plasma glucose concentration (Fig. 5.7) during wk -1, 0, 1, 3, 4, and 5 than cows that did not become pregnant to AI. An interaction between week and subsequent pregnancy status was detected ($P = 0.03$) for NEFA concentration (Fig. 5.8) indicating that postpartum NEFA concentrations were greater in cows that became pregnant during 2 of 5 wk compared with those that did not become pregnant. A tendency for an interaction between week and subsequent pregnancy status was detected ($P = 0.06$) for RF measurement (Fig. 5.9) indicating that RF during 2 of 5 wk after calving was greater in cows that became pregnant compared with those that did not become pregnant to AI.

Measures Normalized to Postpartum Ovulation. Measurements were assessed in a second subset of 12 cows relative to first postpartum ovulation (6 ovulated and 6 were anestrus). None of the potential predictor variables (BCS [Fig. 5.10], BHB [Fig. 5.11], BUN [Fig.5.12], BW [Fig. 5.13], glucose [Fig. 5.14], NEFA [Fig. 5.15], or rump fat [Fig. 5.16]) differed significantly between cows that became pregnant to timed AI compared with those that did not become pregnant to timed AI. Weekly mean differences ($P = 0.01$), however, were detected for BHB, BW, glucose, and NEFA during the pre- and post-first ovulatory period. Both BHB and glucose trended upward from wk -4 through +3, whereas NEFA and BW trended downward during the same period.

Measures Normalized to Timed AI. In a third subset of 34 cows, measures were examined weekly to determine their pattern in relation to eventual pregnancy outcome to TAI

and postpartum estrus-cycle status. Each of the indicator variables varied ($P = 0.01$) by week. Cows that ovulated before the initiation of the TAI program had greater ($P < 0.05$) BCS than anestrus cows, but no difference in BCS was detected between pregnant and nonpregnant cows (Table 5.2). The means for BW, BUN, BHB, glucose, and rump fat did not differ according to ovulation or pregnancy status (Table 5.2).

Circulating NEFA concentration did not differ ($P > 0.60$) between either pregnancy or ovulatory status, but days postpartum at AI affected ($P < 0.01$) NEFA concentration. Furthermore, an interaction ($P < 0.05$) was detected between week and ovulatory status (Fig. 5.17) as well as week and pregnancy status (Fig. 5.18) with NEFA concentrations. For both reproductive statuses, NEFA concentrations were lesser in pregnant and cycling cows compared with their counterparts at or near 6 wk before initiation of timed AI, but the reverse was true when within 2 wk of initiating the timed AI program.

Weekly partial correlations among the 7 variables are summarized in Table 5.3. The summary includes the range in the correlations among the 7 variables for each of the 7 wk before the onset of the timed AI program and their corresponding P values. For each correlation pair illustrated in Table 5.3, the week that the partial correlation was greatest with the smallest P value is reported in Table 5.4. The greatest correlation ($r = 0.73$) was detected between RF and BCS at wk -4. The other variables that were highly correlated ($r > 0.60$) were BW and BCS at wk -3 ($r = 0.61$), BW and RF at wk -5 ($r = 0.64$), and BHB and NEFA concentrations at wk -6 ($r = 0.67$). The multivariate model that examined the influence of all variables on PR identified that at both wk -3 and -5 NEFA concentration accounted for significant ($P < 0.05$) variation in PR.

DISCUSSION

β -hydroxybutyrate

When dairy cows had serum blood concentrations of BHB > 10 mg/dL during the first 2 wk after calving, pregnancy outcomes were compromised compared with cows with lesser BHB (Ospina et al., 2010). In contrast, in another report, cows with BHB > 10 mg/dL did not have poorer pregnancy risk than cows with BHB < 10 mg/dL (Chapinal et al., 2012). In both of the latter studies, greater BHB concentrations were associated with metabolic disease and decreased milk production. Mulliniks et al. (2013) analyzed the calving dates of young suckled beef cows in light of their serum BHB concentrations assessed during the previous year. In year 1 of the experiment, lesser BHB was indicative of earlier calving when cows were sampled at the time of breeding. In the next year of the study, BHB had predictive power when considering a pre-calving concentration in only second-parity cows. Results from experiment 1 corroborate those in the previous report (Mulliniks et al., 2013) in which BHB concentrations were lower in cows that were pregnant 35 d after timed AI compared with those that were not pregnant. Although weekly variations occurred in serum concentrations of BHB in experiment 2 when concentrations were normalized to the week of first postpartum ovulation or to AI, no differences were detected between eventual pregnancy or estrus-cycle statuses of cows. Acute nutritional stress was identified by greater concentrations of BHB when inadequate dietary nutrients were available and metabolism of adipose tissues ensued.

Blood Urea Nitrogen

In experiment 2, we examined the influence of BUN on reproductive status. Dietary RDP is reduced to ammonia in the rumen and then is converted to urea in the liver (Rajala-Schultz et al., 2001). Urea from the liver is measured in the blood stream as BUN. Protein that is not

converted to ammonia in the rumen does not contribute to BUN. The practice of feeding corn byproducts has increased the amount of rumen-undegradable protein (RUP) available to beef cows when supplementation is implemented (Wilson et al., 2015). Circulating concentrations of BUN are sometimes an accurate indicator of the protein status of a cow; however, if RUP is incorporated into the diet, BUN assays may not accurately reflect total protein intake. Cows fed an isocaloric and isonitrogenous diet with elevated RUP did not have altered reproductive performance compared with similar cows fed a diet with elevated RDP (Wilson et al., 2015). The amount of RUP in the diet of the cows in our study was relatively low and, by the end of the study, the diets were composed entirely of native grasses.

Dairy cows with greater concentrations of BUN had poorer fertility than cows with lesser BUN (Rajala-Schultz et al., 2001). In contrast, BUN concentrations were not related to fertility in lactating dairy sheep (Karen et al., 2011). When beef cows were fed a diet with elevated RUP during gestation, they were reported to have lower BUN and lighter birth weight calves than cows fed a diet with elevated RDP; however, dystocia and subsequent reproductive performance did not differ between cows fed protein with differing ruminal degradabilities (Radunz et al., 2010). In another study, pregnancy risk in primiparous beef cows was not associated with BUN concentrations (Wiley et al., 1991). In a study conducted in Africa, Bonsmara heifers fed a protein-rich diet had poorer pregnancy risk than heifers consuming less protein (Tshuma et al., 2014). Elevated BUN concentration has been associated with earlier puberty (Cappellozza et al., 2014), but impaired oocyte competence in beef heifers (Sinclair et al., 2000). Some variability in BUN concentration was detected among weeks in our study, but no significant influence on PR was observed. It is likely that the protein concentrations in the diet of these cows resulted in serum BUN concentrations that were within the range for acceptable reproductive performance.

Glucose

Volatile fatty acids in the ruminant are the primary energy sources for most bodily functions. Milk synthesis in the lactating female, in contrast, is dependent on glucose availability. Reproductive processes and tissues including oocyte development also require glucose (Berlinger et al., 2012). The physiological status of beef cows after parturition seems to influence the glucose concentration. In experiment 1, glucose sampling 10 d before timed AI indicated that lesser circulating glucose concentrations were associated with greater pregnancy outcomes to AI. These results indicated that glucose concentrations are associated with subsequent pregnancy outcome.

A decrease in plasma glucose in early postpartum dairy cows indicates an energy partitioning priority that favors lactation over reproduction (Lucy et al., 2013). Although beef cows do not produce the same quantity of milk as dairy cows, partitioning priorities are likely similar. When early postpartum lactating dairy cows were infused with glucose in stepwise increasing doses, the physiological upper limit of plasma glucose concentration was accompanied by rapid decreases in NEFA and BHB concentrations (Lucy et al., 2013). In another study, plasma glucose concentration on d 3 postpartum was related to reproductive success at the first insemination after calving in lactating dairy cows (Garverick et al., 2013).

Glucose is likely more sensitive to nutritional status and nutrient availability than measures of stored adipose tissue such as BCS. When beef cows were sampled for glucose concentration 31 and 61 d after calving, plasma glucose did not differ between cows with BCS of 4 vs. 6 (Lake et al., 2006). Contrary to the report in dairy cows (Garverick et al., 2013), Mulliniks et al. (2013) reported that beef cows having greater plasma glucose concentrations were less likely to become pregnant early in the breeding season. Samples in the latter study

were collected during 60 d before calving compared with d 3 postpartum in the dairy cow study (Garverick et al., 2013). In experiment 2, plasma glucose concentrations before and after calving were consistently less in cows that were pregnant to timed AI compared with those that were not pregnant. These reduced blood glucose concentrations may indicate lesser amount of lactation in beef cows and partial energy sparing to support reproductive processes necessary for establishment of pregnancy. In contrast to pregnancy success being associated with lesser peripartum concentrations of glucose, greater concentrations of plasma glucose throughout the study period were associated with earlier first postpartum ovulation.

Temporal differences in glucose concentration, dependent on the time of collection relative to feeding also have been noted (Lake et al. 2006). Daily variations in glucose concentrations can make accurate interpretation of glucose data difficult. In addition, rapid changes in glucose concentration after feeding and other physiological events complicate interpretation of glucose status. Nevertheless, the predictive power of glucose on reproductive success warrants further examination. The quantification of the relationship between glucose and reproductive success could lead to an inexpensive and effective chute-side, pre-breeding reproductive fitness test.

Non-Esterified Fatty Acids

Ruminants including beef cows use propionate and acetate as their primary energy source (Harmon, 1992). During periods when digested energy supply is inadequate to meet nutritional requirements, such as during lactation, stored lipids are mobilized as NEFA for conversion to energy. In dairy cows, in which negative energy balance is easier to quantify than in beef cows, early lactation is associated with decreased concentrations of glucose and insulin and increased concentrations of NEFA (Overton and Waldron, 2004). In agreement with the dairy data, Lake et

al. (2006) reported an inverse relationship between insulin and NEFA in postpartum beef cows. Furthermore, we observed greater concentrations of NEFA at or shortly after calving in experiment 2 compared with prepartum cows. A study conducted in dairy cows also indicated that cows with NEFA concentration > 0.70 mEq/L during the first 2 wk of lactation were more likely to have lesser PR and milk yield than their herd mates with lesser NEFA (Ospina et al., 2010). A larger more geographically diverse study (Chapinal et al., 2012) indicated milk yield was reduced in cows with elevated concentrations of NEFA during the first 2 wk postpartum but no effect on subsequent PR was detected.

Beef heifers infused with VFA responded with greater blood concentrations of insulin and lesser NEFA (DiConstanzo et al., 1999). Primiparous beef cows with greater concentrations of NEFA before calving had longer intervals of postpartum anestrus than primiparous cows with lesser NEFA concentration (Guedon et al., 1999). When cows reached the nadir of negative energy balance and available energy exceeds requirements, NEFA concentrations started to decrease (Gross et al., 2011). This finding was corroborated in experiment 2 as days since calving influenced circulating NEFA concentration. We also found that there was an interaction between week and reproductive status when analyzing NEFA concentrations. Cows that resumed estrous cycles or became pregnant had lesser circulating NEFA 4 to 6 wk before AI, but greater concentrations in the weeks immediately preceding AI. All cows had a decrease in NEFA concentration that was associated with improving range conditions. The earlier decrease noted in reproductively successful cows indicates greater nutritional efficiency. The greater NEFA concentrations noted after presumed negative energy balance nadir in cows that became pregnant indicates a baseline circulating NEFA concentration that is conducive to reproduction. Although postpartum nutrient availability was important, nutritional changes during the last 30 d before AI

translated into greater PR. Serum NEFA concentration may be a good indicator of NEB, and at certain critical time points, may be a predictor of PR.

Physical Indicators

Short et al. (1990) proposed that until a critical amount of body adipose reserves are satisfied, no energy is partitioned for the establishment of pregnancy. Cows that calved with a body condition score of 5 or greater had shorter postpartum intervals to first estrus. In the current study, cows that ovulated before the AI period had greater BCS than cows that did not ovulate. In support of the positive influence of prepartum BCS on future reproductive performance, Ayres et al. (2014) reported that Zebu cattle with greater BCS and with greater depth of RF at calving had improved PR during the breeding season than Zebu cattle with lesser BCS and RF. In contrast, BCS at calving was not related to future reproductive performance in young *Bos taurus* cows grazing in New Mexico (Mulliniks et al., 2012). Furthermore, BCS at calving was an inadequate indicator of breeding competence in primiparous beef cows studied in Montana (Roberts, 2008). In the current study, BCS was a significant indicator of earlier postpartum ovulation and PR associated with timed AI in experiment 1, but not in experiment 2 with a limited number of cows.

Variability of BCS assessment and the inability to detect subtle changes in body condition has promoted the search for a more precise measure of energy status. Body weight in ruminants is highly variable depending on feeding times and gut fill. In a study investigating postpartum changes in BCS and RF, cows that maintained or gained fat reserves had greater PR than cows that became thinner (Looper et al., 2010). Ultrasound measurements of fat deposition are repeatable among technicians (Brethour, 1992) and have the potential to accurately monitor subtle changes in body composition in field conditions (Odhiambo et al., 2009). In the current

study, all cows had similar RF measurements except for anestrous cows that did not become pregnant to AI, which had lesser RF than their herd mates. Cows that became pregnant to timed AI tended to have lesser RF at calving, but tended to have greater RF depth 4 wk after calving than cows that did not become pregnant. Detectable changes in fat deposition could be attributed to energy utilization, changes in energy intake, or differing nutrient partitioning priority in the cows that became pregnant. Weekly changes in BW were noted in the current report; however, no relationship was established between BW and either PR or postpartum resumption of estrus cycles.

Summary

The complexity of the nutritional impact on the establishment of pregnancy is highlighted in the results of the current experiments. The measures of BCS and RF near the time of calving predicted earlier first postpartum ovulation. Fat reserves as indicated by RF, but not BCS, may be predictive of pregnancy success. Body condition is not necessarily characterized by a static measure of BCS or RF at a single time point. Many anestrous cows routinely become pregnant to TAI programs, thus complicating the process of finding consistent predictive indicators. Concentrations of glucose and NEFA during the peripartum period indicate the nutritional status of the cow. Relationships exist between these metabolic indicators and pregnancy success; however, RF measurement may be nearly as accurate and a more cost-effective indicator of breeding fitness than assessing blood metabolites. More research is warranted to identify the most accurate physical indicators and specific early predictive value of metabolic indicators.

LITERATURE CITED

- Ayres, H., R. M. Ferreira, J. R. Torres-Junior, C. G. Demetrio, M. F. Sa Filho, L. U. Gimenes, L. Pentead, M. J. D'Occhio, and P. S. Baruselli. 2014. Inferences of body energy reserves on conception rate of suckled zebu beef cows subjected to timed artificial insemination followed by natural mating. *Theriogenology* 82:529-536. doi: 10.1016/j.theriogenology.2014.04.026.
- Bellows, R. A., R. E. Short, and G. V. Richardson. 1982. Effects of sire, age of dam and gestation feed level on dystocia and postpartum reproduction. *J. Anim. Sci.* 55:18–27.
- Berlinguer, F., A. Gonzalez-Bulnes, I. Contreras-Solis, A. Spezzigu, L. Torres-Rovira, S. Succu, S. Naitana, and G. G. Leoni. 2012. Glucogenic supply increases oocyte developmental competence in sheep. *J. Reprod. Fertil.* 24:1055–1062.
- Brethour, J. R. 1992. The repeatability and accuracy of ultrasound in measuring back fat of cattle. *J. Anim. Sci.* 70:1039–1044.
- Cappellozza, B. I., R. F. Cooke, M. M. Reis, P. Moriel, D. H. Keisler, and D. W. Bohnert. 2014. Supplementation based on protein or energy ingredients to beef cattle consuming low-quality cool-season forages: I. performance, reproductive, and metabolic responses of replacement heifers. *J. Anim. Sci.* 92:2725–2734. doi:10.2527/jas.2013–7442.
- Chapinal, N., M. E. Carson, S. J. LeBlanc, K. E. Leslie, S. Godden, M. Capel, J. E. Santos, M. W. Overton, and T. F. Duffield. 2012. The association of serum metabolites in the transition period with milk production and early-lactation reproductive performance. *J. Dairy Sci.* 95:1301–1309. doi:10.3168/jds.2011–4724.

- DiCostanzo, A., J. E. Williams, and D. H. Keisler. 1999. Effects of short- or long-term infusions of acetate or propionate on luteinizing hormone, insulin, and metabolite concentrations in beef heifers. *J. Anim. Sci.* 77:3050–3056.
- Garverick, H. A., M. N. Harris, R. Vogel-Blue, J. D. Sampson, J. Bader, W. R. Lamberson, J. N. Spain, M. C. Lucy, and R. S. Youngquist. 2013. Concentrations of nonesterified fatty acids and glucose in blood of periparturient dairy cows are indicative of pregnancy success at first insemination. *J. Dairy Sci.* 96:181–188. doi:10.3168/jds.2012-5619.
- Gross, J., H. A. van Dorland, R. M. Bruckmaier, and F. J. Schwarz. 2011. Performance and metabolic profile of dairy cows during a lactational and deliberately induced negative energy balance with subsequent realimentation. *J. Dairy Sci.* 94:1820–1830. doi:10.3168/jds.2010-3707.
- Guedon, L., J. Saumande, and B. Desbals. 1999 Relationships between calf birth weight, prepartum concentrations of plasma energy metabolites and resumption of ovulation postpartum in Limousine suckled beef cows. *Theriogenology* 52:779–789.
- Harmon, D. L. 1992. Impact of nutrition on pancreatic exocrine and endocrine secretion in ruminants: A review. *J. Anim. Sci.* 70:1290–1301.
- Karen, A. M., P. Kovacs, J. F. Beckers, N. M. de Sousa, and O. Szenci. 2011. Plasma urea nitrogen in relation to pregnancy rate in dairy sheep. *Anim. Reprod. Sci.* 124:69–72. doi:10.1016/j.anireprosci.2011.01.012.
- Lake, S. L., E. J. Scholljegerdes, D. M. Hallford, G. E. Moss, D. C. Rule, and B. W. Hess. 2006. Effects of body condition score at parturition and postpartum supplemental fat on metabolite and hormone concentrations of beef cows and their suckling calves. *J. Anim. Sci.* 84:1038–1047. doi:84/4/1038.

- Looper, M. L., S. T. Reiter, B. C. Williamson, M. A. Sales, D. M. Hallford, and C. F. Rosenkrans Jr. 2010. Effects of body condition on measures of intramuscular and rump fat, endocrine factors, and calving rate of beef cows grazing common bermudagrass or endophyte-infected tall fescue. *J. Anim. Sci.* 88:4133-4141. doi: 10.2527/jas.2010-3192.
- Lucy, M. C., R. C. Escalante, D. H. Keisler, W. R. Lamberson, and D. J. Mathew. 2013. Short communication: Glucose infusion into early postpartum cows defines an upper physiological set point for blood glucose and causes rapid and reversible changes in blood hormones and metabolites. *J. Dairy Sci.* 96:5762–5768. doi:10.3168/jds.2013–6794.
- Mulliniks, J. T., S. H. Cox, M. E. Kemp, R. L. Endecott, R. C. Waterman, D. M. Vanleeuwen, and M. K. Petersen. 2012. Relationship between body condition score at calving and reproductive performance in young postpartum cows grazing native range. *J. Anim. Sci.* 90:2811–2817. doi:10.2527/jas.2011–4189.
- Mulliniks, J. T., M. E. Kemp, R. L. Endecott, S. H. Cox, A. J. Roberts, R. C. Waterman, T. W. Geary, E. J. Scholljegerdes, and M. K. Petersen. 2013. Does beta-hydroxybutyrate concentration influence conception date in young postpartum range beef cows? *J. Anim. Sci.* 91:2902–2909. doi:10.2527/jas.2012–6029.
- Odhiambo, J. F., J. D. Rhinehart, R. Helmondollar, J. Y. Pritchard, P. I. Osborne, E. E. Felton, and R. A. Dailey. 2009. Effect of weaning regimen on energy profiles and reproductive performance of beef cows. *J. Anim. Sci.* 87:2428-2436. doi: 10.2527/jas.2008-1138.
- Ospina, P. A., D. V. Nydam, T. Stokol, and T. R. Overton. 2010. Evaluation of nonesterified fatty acids and beta-hydroxybutyrate in transition dairy cattle in the northeastern United

- States: Critical thresholds for prediction of clinical diseases. *J. Dairy Sci.* 93:546–554.
doi:10.3168/jds.2009–2277.
- Overton, T. R., and M. R. Waldron. 2004. Nutritional management of transition dairy cows: Strategies to optimize metabolic health. *J. Dairy Sci.* 87(E. Suppl.):E105–119.
- Radunz, A. E., F. L. Fluharty, M. L. Day, H. N. Zerby, and S. C. Loerch. 2010. Prepartum dietary energy source fed to beef cows: I. Effects on pre- and postpartum cow performance. *J. Anim. Sci.* 88:2717–2728. doi:10.2527/jas.2009–2744.
- Rajala-Schultz, P. J., W. J. A. Saville, G. S. Frazer, and T. E. Wittum. 2001. Association between milk urea nitrogen and fertility in Ohio dairy cows. *J. Dairy Sci.* 84:482–489.
- Roberts, A. J. 2008. Assessment of insulin-like growth factor-1 as an indicator of competence for rebreeding in first calf heifers. *Proc. West. Sec. Anim. Sci.* 59:257-260.
- Short, R.E., and D.C. Adams. 1988. Nutritional and hormonal interrelationships in beef cattle reproduction. *Can. J. Anim. Sci.* 68:29–39.
- Short, R. E., R. A. Bellows, R. B. Staigmiller, J. G. Berardinelli, and E. E. Custer. 1990. Physiological mechanisms controlling anestrus and infertility in postpartum beef cattle. *J. Anim. Sci.* 68:799-816.
- Sinclair, K. D., M. Kuran, F. E. Gebbie, R. Webb, and T. G. McEvoy. 2000. Nitrogen metabolism and fertility in cattle: II. Development of oocytes recovered from heifers offered diets differing in their rate of nitrogen release in the rumen. *J. Anim. Sci.* 78:2670–2680.
- Stevenson, J. S., S. L. Pulley, and H. I. Mellieon Jr. 2012. Prostaglandin F_{2α} and gonadotropin-releasing hormone administration improve progesterone status, luteal number, and proportion

of ovular and anovular dairy cows with corpora lutea before a timed artificial insemination program. *J. Dairy Sci.* 95:1831–44. doi: 10.3168/jds.2011-4767.

Tshuma, T., D. E. Holm, G. T. Fosgate, and D. C. Lourens. 2014. Pre-breeding blood urea nitrogen concentration and reproductive performance of Bonsmara heifers within different management systems. *Trop. Anim. Health Prod.* 46:1023–1030. doi:10.1007/s11250-014-0608-3.

Wiley, J. S., M. K. Petersen, R. P. Ansotegui, and R. A. Bellows. 1991. Production from first-calf beef heifers fed a maintenance or low level of prepartum nutrition and ruminally undegradable or degradable protein postpartum. *J. Anim. Sci.* 69:4279–4293.

Wilson, T. B., D. B. Faulkner, and D. W. Shike. 2015. Influence of late gestation dry lot rations differing in protein degradability and fat content on beef cow and subsequent calf performance. *J. Anim. Sci.* 93: 5819-5828. doi: 10.2527/jas.2014-8805.

Table 5.1.

Characteristics of suckled beef cows enrolled in experiment 1

Location ¹	Breed ²	<i>n</i>	2 yr. old (%)	Days postpartum at AI ³	BCS ³	Pregnancy risk ⁴ %	Estrus- cycle status ⁵ %
KS-1	A x H	37	0	67 ± 4.9	5.3 ± 0.08	43.2	35.1
KS-2	A x H	178	0	93 ± 1.1	5.7 ± 0.03	67.4	55.1
KS-3	A x H	18	0	74 ± 3.9	6.4 ± 0.14	33.3	... ⁶
KS-4	A x H	58	100	62 ± 2.1	5.1 ± 0.07	6.9	27.6
KS-5	A, H, S	64	0	75 ± 1.7	4.8 ± 0.07	67.2	... ⁶
KS-6	A x H	27	96	79 ± 0.5	5.3 ± 0.08	33.3	29.6
KS-7	A x H	86	0	93 ± 5.1	5.7 ± 0.10	29.4	45.4
KS-8	A x H	57	0	67 ± 2.9	6.9 ± 0.10	78.9	... ⁶
KS-9	A x H	56	46	69 ± 2.5	6.1 ± 0.12	37.5	27.6
KS-10	A x H	49	20	65 ± 1.6	4.5 ± 0.06	44.9	... ⁶
KS-11	A x H	29	0	61 ± 4.2	6.8 ± 0.11	41.4	... ⁶

¹Cows at 11 locations were enrolled.²A = Angus, H =Hereford, and S =Simmental.³Mean ± SE.⁴Assessed at 35 d after AI.⁵Based on progesterone concentrations measured in 2 blood samples collected 10 d apart before the onset of the timed AI protocol.⁶Blood samples were not collected to assess estrus-cycle status.

Table 5.2.

Reproductive status and associated indicator values for cows with 7 weekly samples between calving and initiation of a timed AI program (experiment 2)

Trait	<i>n</i>	BW ¹ , kg	BCS ²	BUN ³ , mg/dL	BHB ⁴ , (μ M)	Glucose, mg/dL	Rump fat. mm
Ovulation							
Yes	20	458 \pm 17	4.8 ^a \pm 0.1	24.2 \pm 1.1	423 \pm 19	60.8 \pm 1.3	2.11 \pm 0.05
No	14	491 \pm 23	4.4 ^b \pm 0.1	26.8 \pm 1.4	426 \pm 25	55.6 \pm 1.8	2.12 \pm 0.06
Pregnancy status							
Pregnant	18	478 \pm 6	4.6 \pm 0.1	24.9 \pm 1.0	432 \pm 17	58.5 \pm 1.2	2.15 \pm 0.04
Open	16	461 \pm 7	4.5 \pm 0.1	26.1 \pm 1.2	416 \pm 21	57.9 \pm 1.5	2.08 \pm 0.05

^{a,b}Least square means with different letters within column trait differ ($P < 0.05$).

¹Body weight.

²Body condition score (1 = thin and 9= fat).

³Blood urea nitrogen.

⁴Beta-hydroxybutyrate.

Table 5.3.

Range in partial correlations and their respective *P*-values among the 7 indicator variables during each of 7 wk before the onset of a timed AI program¹ (experiment 2)

Trait	Body weight	Rump fat	NEFA	BUN	BHB	Glucose
BCS	0.20 - 0.61	0.09 - 0.73	(0.37) - 0.18	(0.37) - 0.28	(0.08) - 0.52	(0.22) - 0.55
	0.01 - 0.25	0.01 - 0.67	0.03 - 0.92	0.03 - 0.98	0.01 - 0.64	0.01 - 0.91
Body weight		0.21 - 0.64	(0.22) - 0.49	(0.38) - 0.24	(0.02) - 0.59	(0.18) - 0.33
		0.01 - 0.27	0.01 - 0.87	0.02 - 0.99	0.01 - 0.88	0.07 - 0.93
Rump fat			(0.33) - 0.35	(0.24) - 0.39	(0.18) - 0.31	(0.17) - 0.37
			0.06 - 0.90	0.03 - 0.62	0.14 - 0.98	0.08 - 0.57
NEFA				(0.22) - 0.31	(0.34) - 0.67	(0.29) - 0.05
				0.07 - 0.79	0.01 - 0.85	0.11 - 0.84
BUN					(0.24) - 0.01	(0.16) - 0.32
					0.03 - 0.95	0.13 - 0.97
BHB						(0.44) - 0.11
						0.01 - 0.89

¹Unshaded lines show maximum and minimum partial correlations (negative correlations are in parenthesis) among variables. Shaded lines report the minimum and maximum *P*-values.

Table 5.4.

The week relative to timed AI having the most significant partial correlations for each pair of variable correlations in Table 5.3¹.

Trait	Body weight	Rump fat	NEFA	BUN	BHB	Glucose
BCS	3rd	4th	(5th)	(6th)	1st	3rd
Body weight	...	5th	(2nd)	(2nd)	4th	6th
Rump fat	(7th)	4th	1st	1st
NEFA	(3rd)	6th	(6th)
BUN	(4th)	1st
BHB	(6th)

¹Ordinal week numbers in parentheses represent negative correlations.

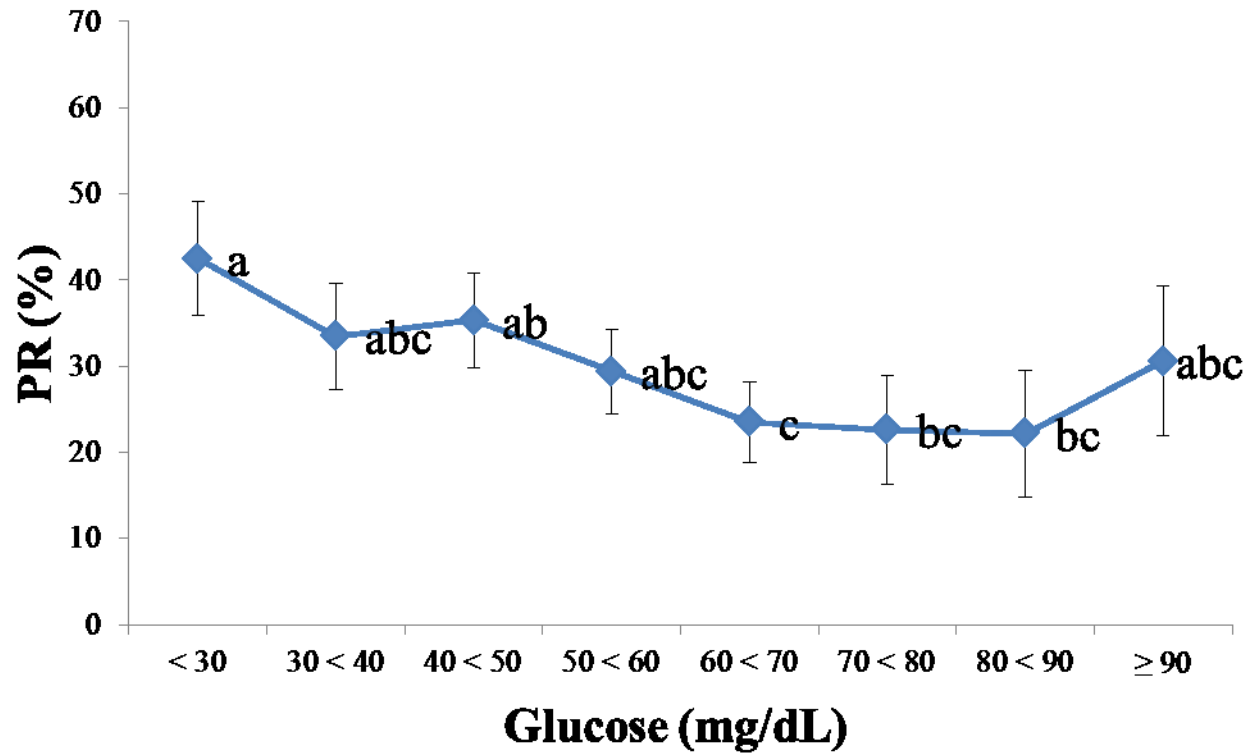

Figure 5.1.

Pregnancy risk (PR) regressed on defined concentrations of plasma glucose in 602 suckled beef cows (experiment 1). Data points with different letters differ ($P < 0.05$).

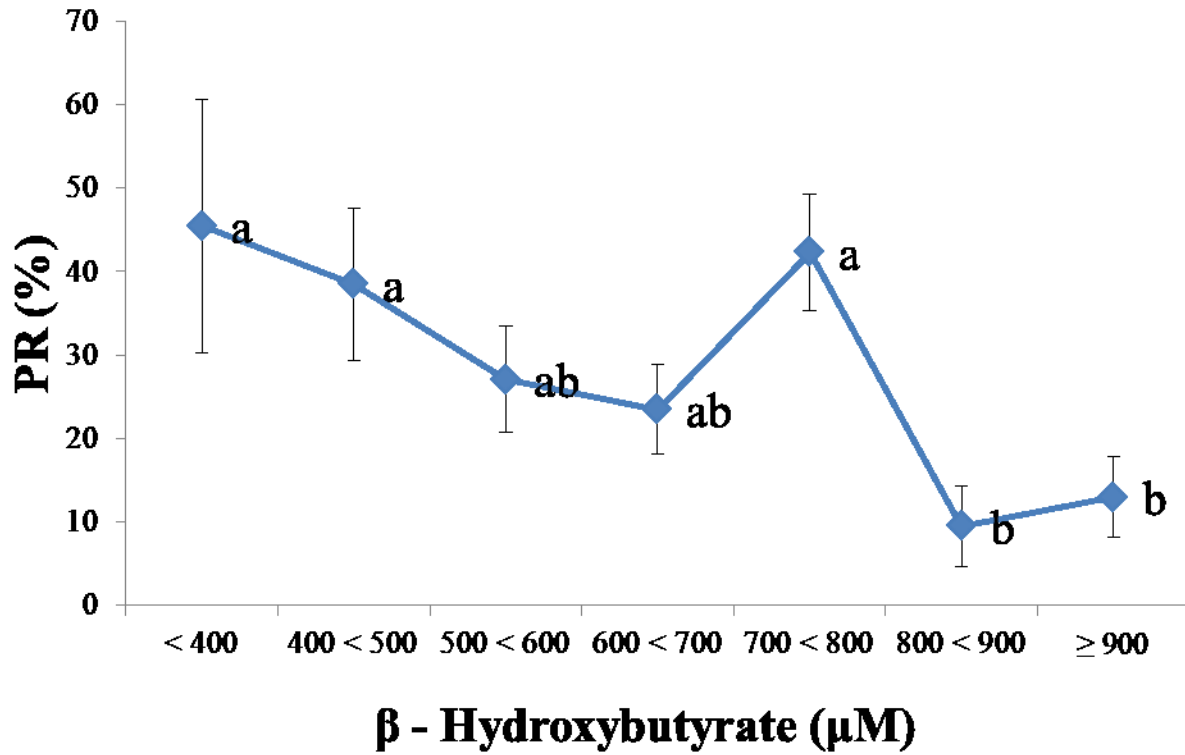

Figure 5.2.

Pregnancy risk (PR) regressed on defined serum concentrations of β -hydroxybutyrate in 207 suckled beef cows (experiment 1). Data points with different letters differ ($P < 0.05$).

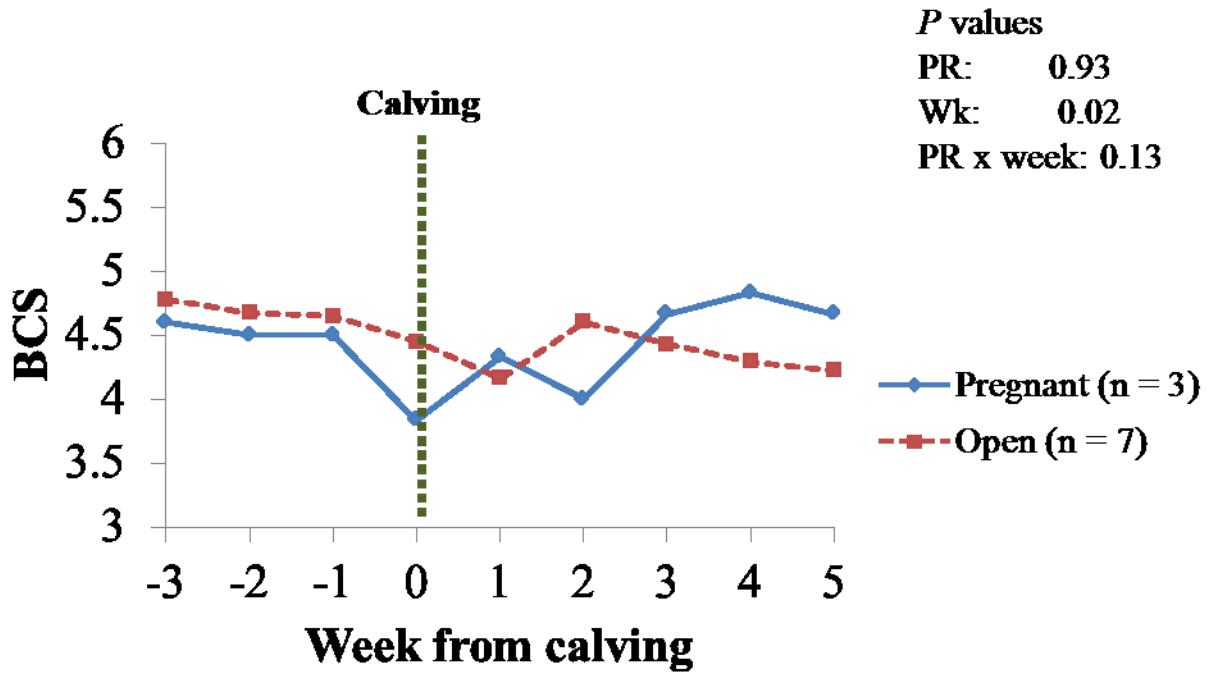

Figure 5.3.

Least squares mean (\pm SE = 0.07) body condition scores (BCS) during a 9-wk peripartum period according to eventual pregnancy risk (PR).

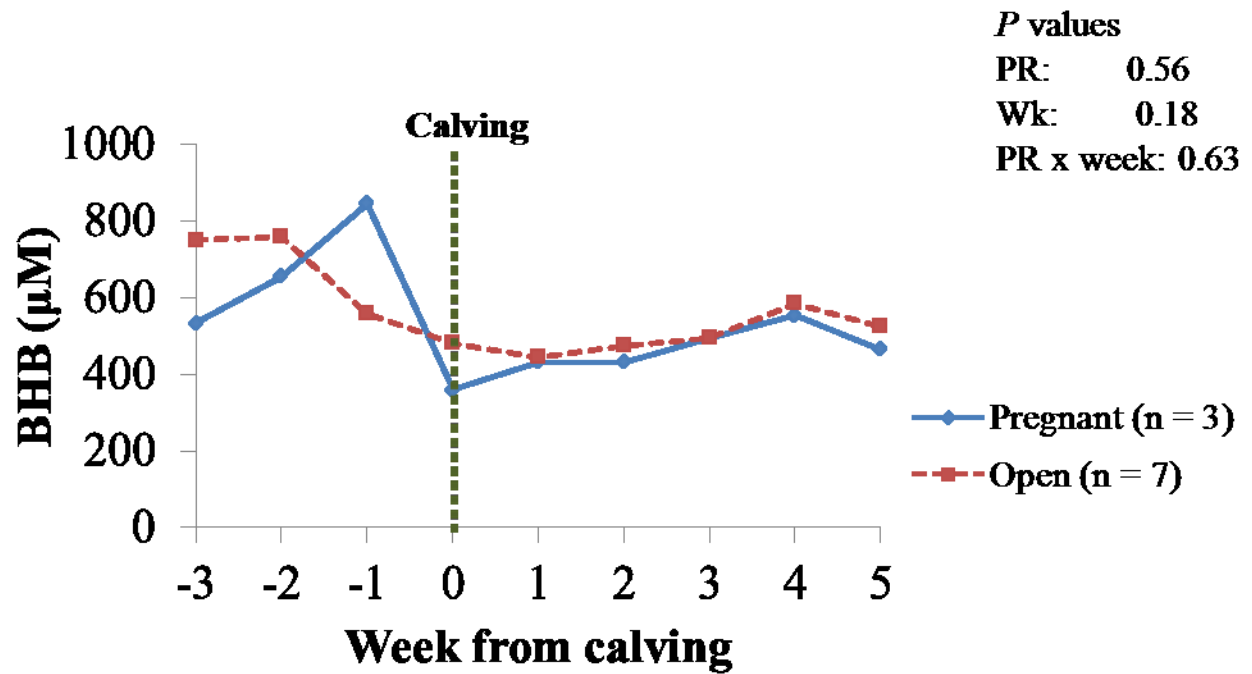

Figure 5.4.

Least squares mean (\pm SE = 40 μ M) serum concentrations of β -hydroxybutyrate (BHB) during a 9-wk peripartum period according to eventual pregnancy risk (PR).

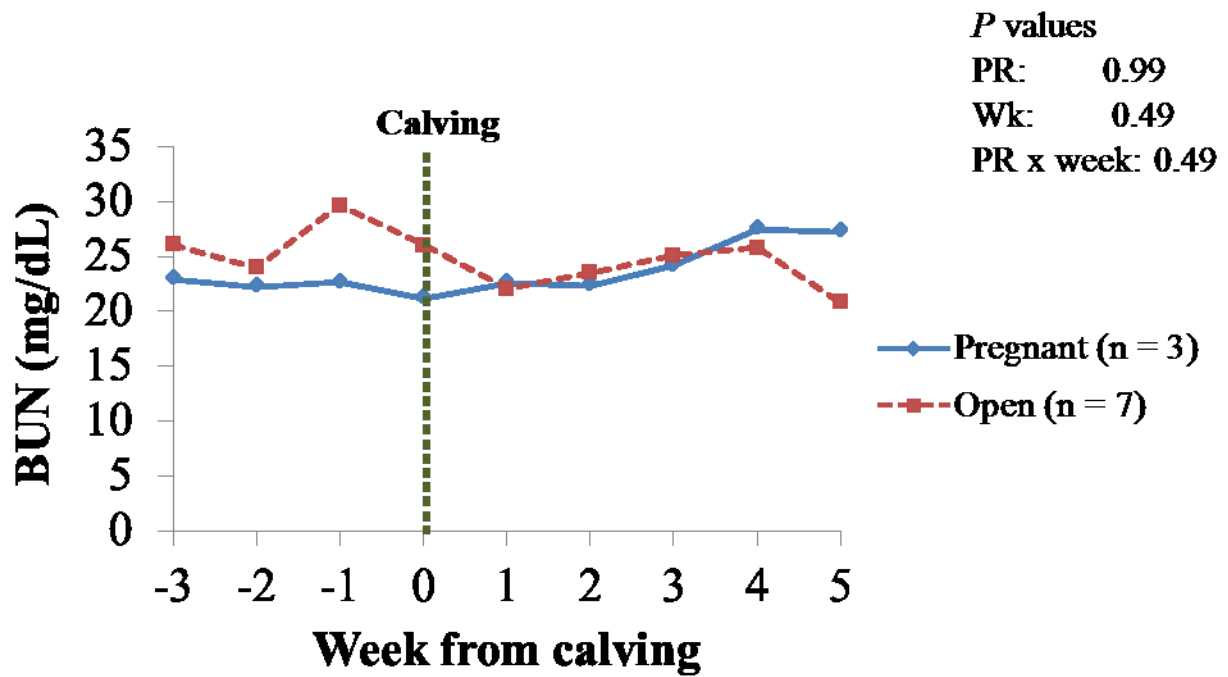

Figure 5.5.

Least squares mean (\pm SE = 1.1 mg/dL) serum concentrations of blood urea nitrogen (BUN) during a 9-wk peripartum period according to eventual pregnancy risk (PR).

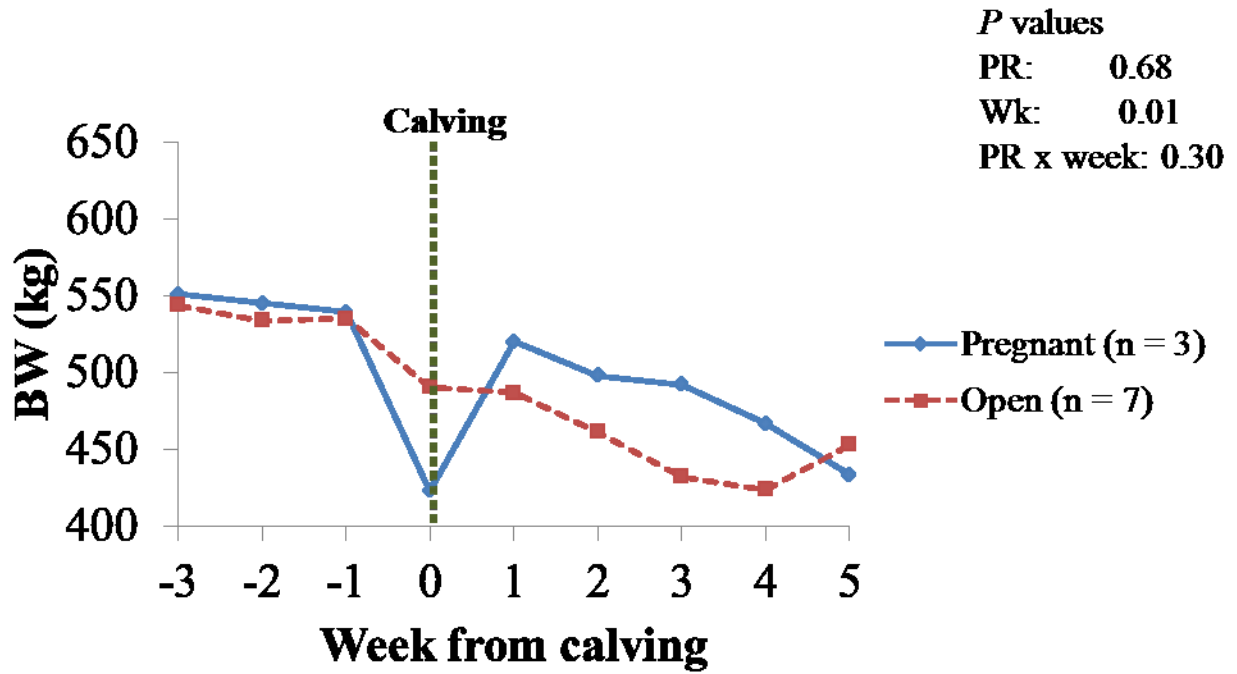

Figure 5.6.

Least squares mean (\pm SE = 15 kg) body weight (BW) during a 9-wk peripartum period according to eventual pregnancy risk (PR).

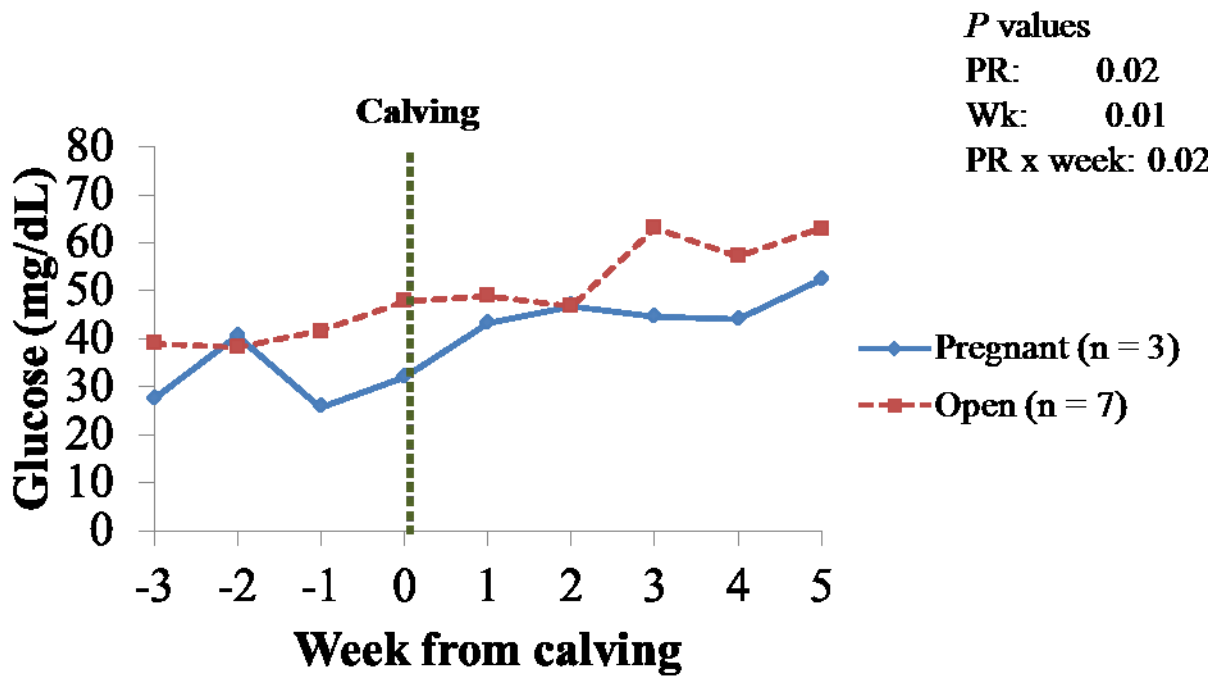

Figure 5.7.

Least squares mean (\pm SE = 1.6 mg/dL) plasma concentration of glucose during a 9-wk peripartum period according to eventual pregnancy risk (PR).

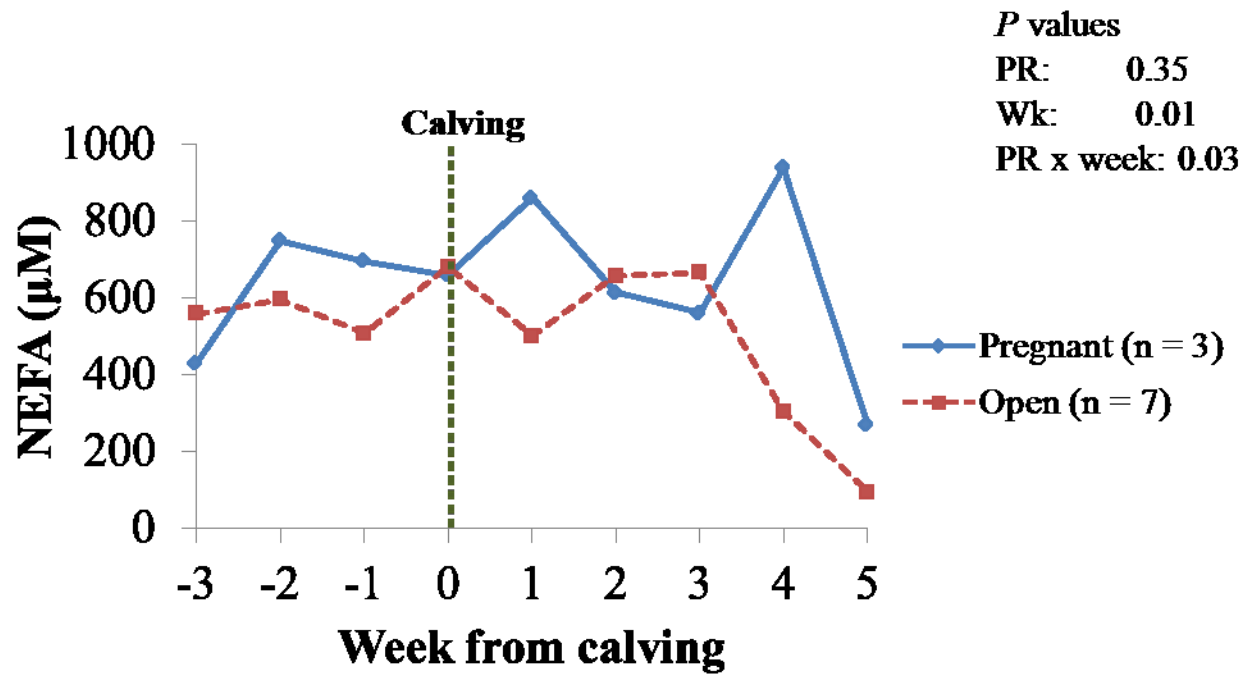

Figure 5.8.

Least squares mean (\pm SE = 43 μ M) serum concentrations of NEFA during a 9-wk peripartum period according to eventual pregnancy risk (PR).

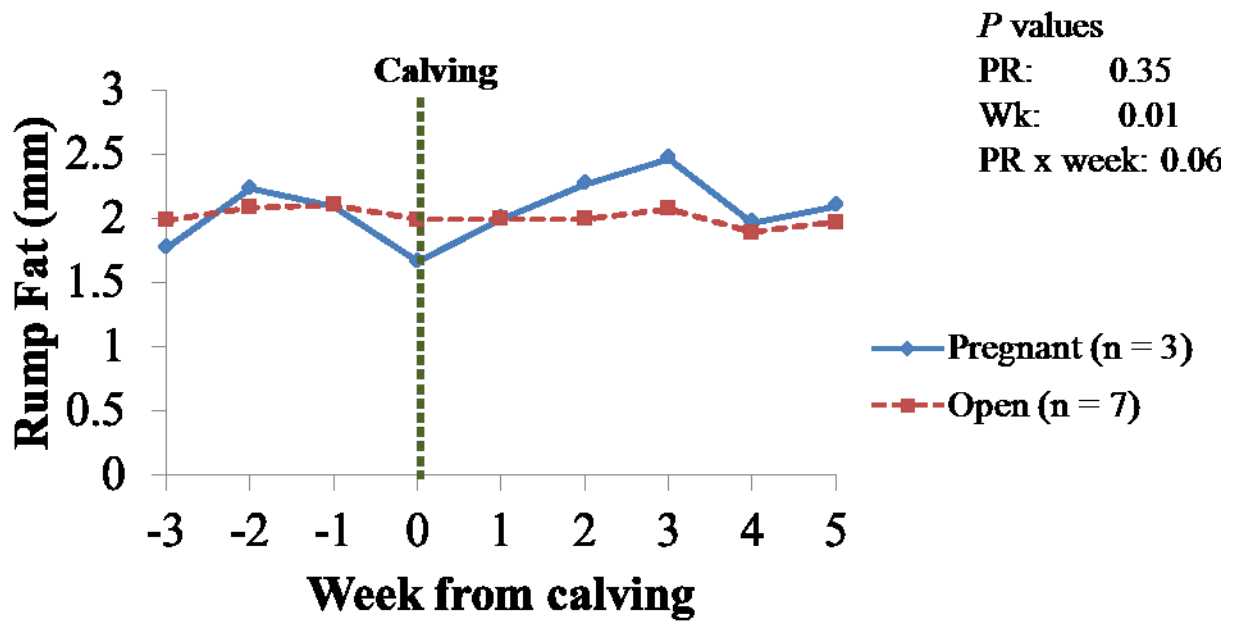

Figure 5.9.

Least squares mean (\pm SE = 0.03 mm) rump fat depth during a 9-wk peripartum period according to eventual pregnancy risk (PR).

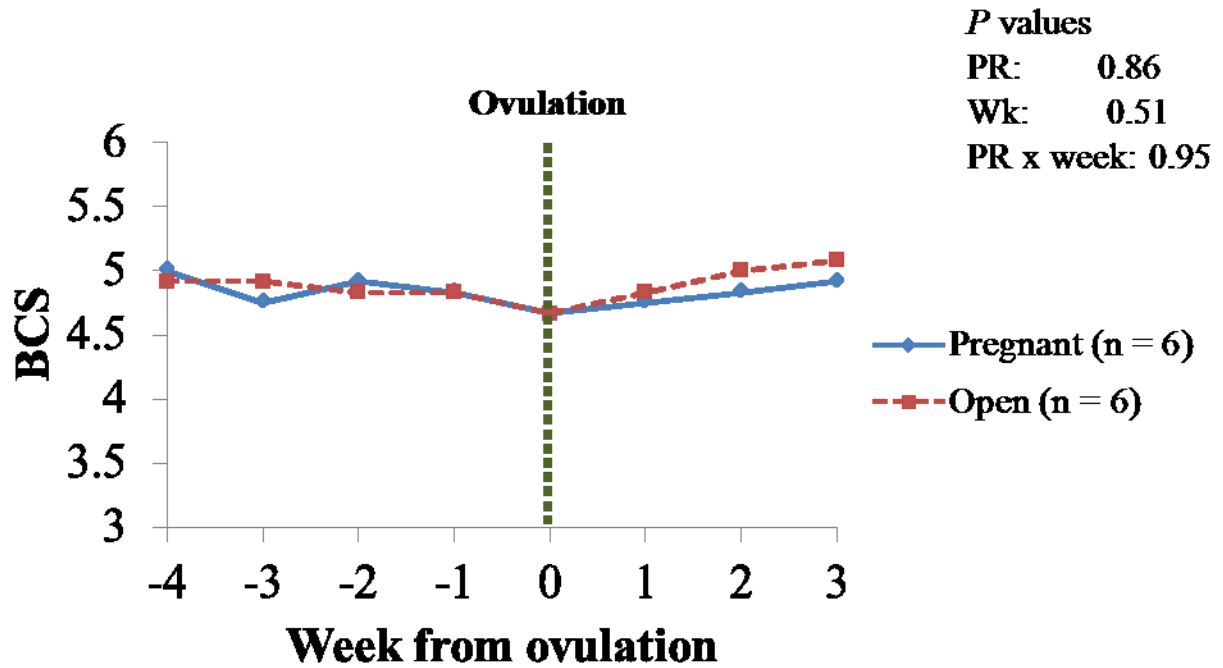

Figure 5.10.

Least squares mean (\pm SE = 0.21) body condition scores (BCS) during an 8-wk period encompassing the week of first postpartum ovulation according to eventual pregnancy risk (PR).

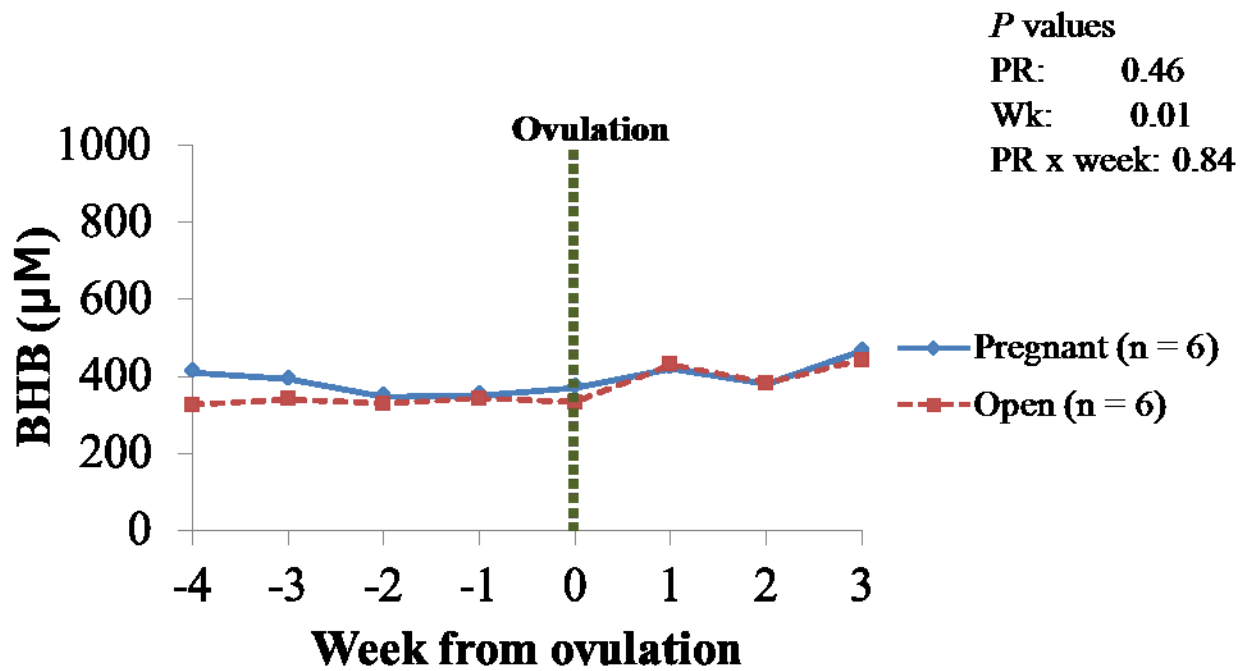

Figure 5.11.

Least squares mean (\pm SE = 24 μ M) serum concentration of β -hydroxybutyrate (BHB) during an 8-wk period encompassing the week of first postpartum ovulation according to eventual pregnancy risk (PR).

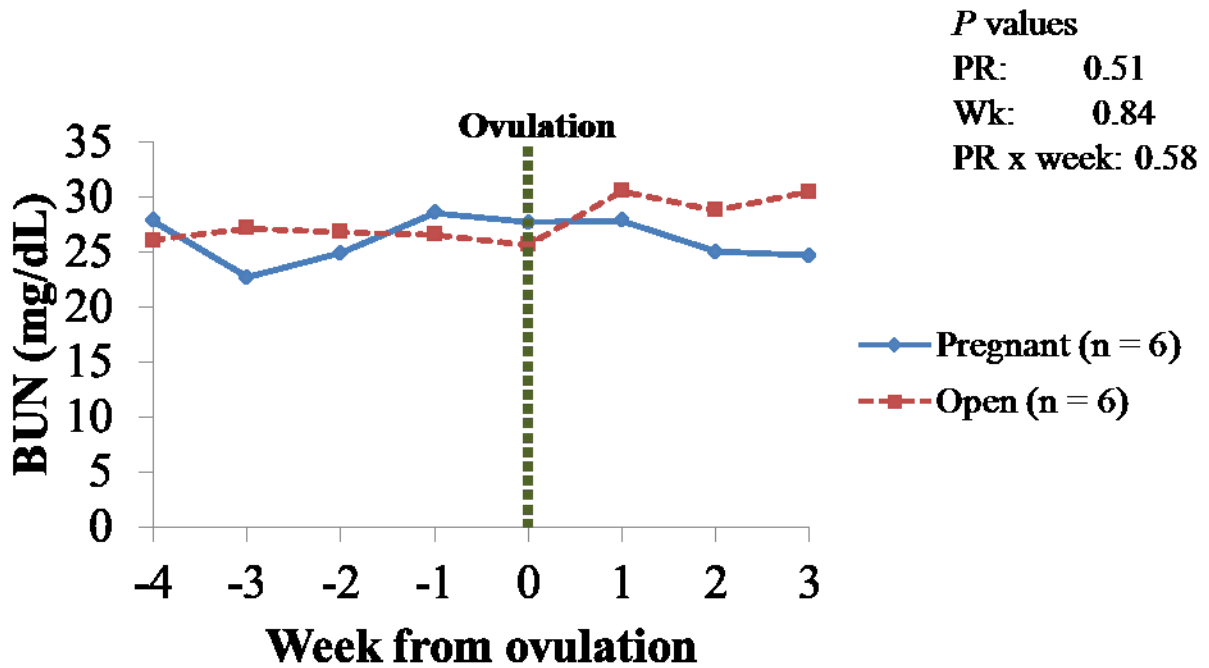

Figure 5.12.

Least squares mean (\pm SE = 1.6 mg/dL) serum concentration of blood urea nitrogen (BUN) during an 8-wk period encompassing the week of first postpartum ovulation according to eventual pregnancy risk (PR).

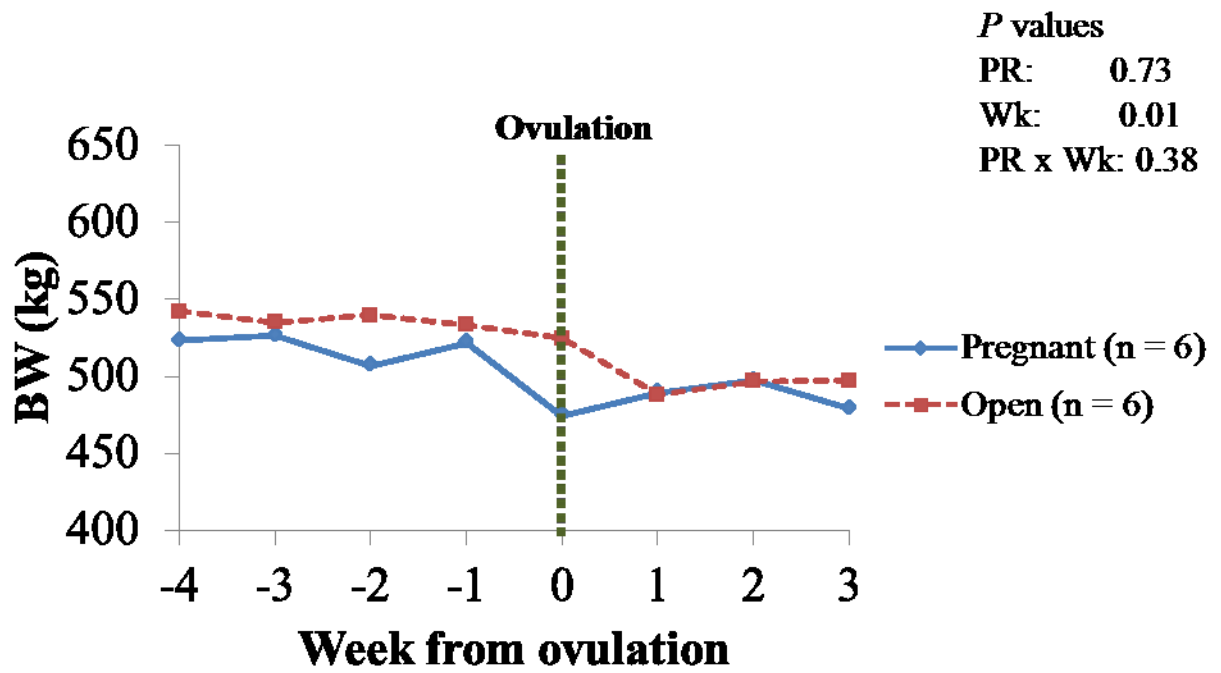

Figure 5.13.

Least squares mean (\pm SE = 34 kg) body weight (BW) during an 8-wk period encompassing the week of first postpartum ovulation according to eventual pregnancy risk (PR).

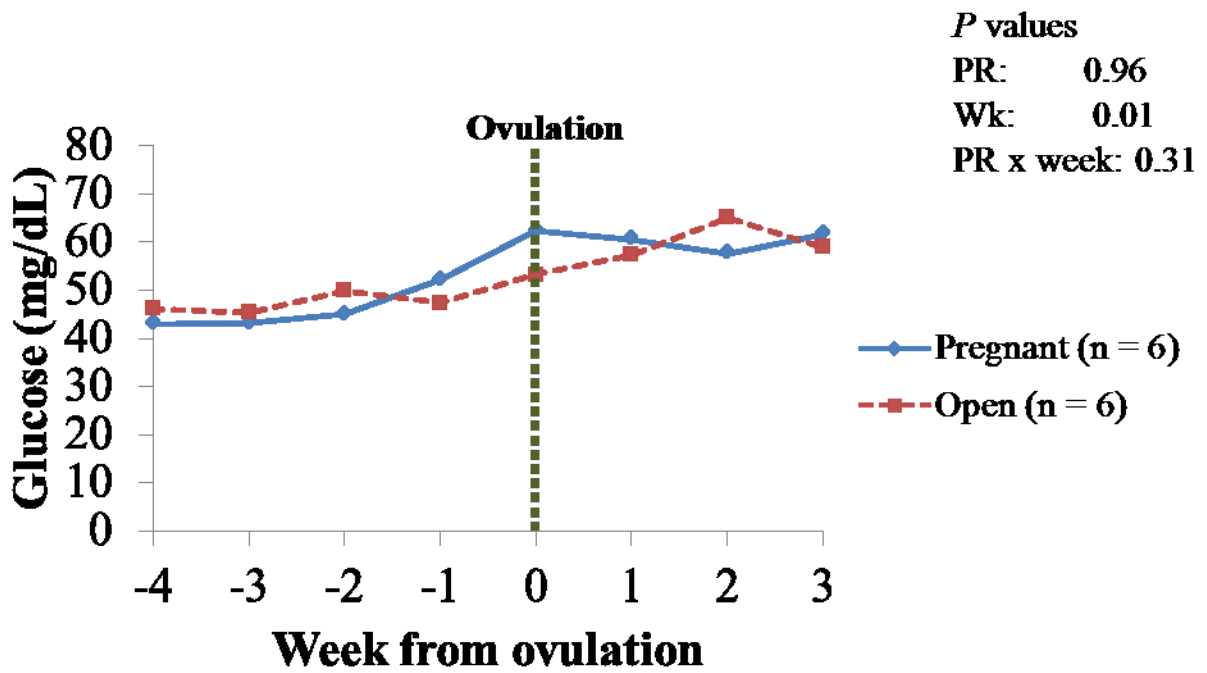

Figure 5.14.

Least squares mean (\pm SE = 2.4 mg/dL) plasma concentration of glucose during an 8-wk period encompassing the week of first postpartum ovulation according to eventual pregnancy risk (PR

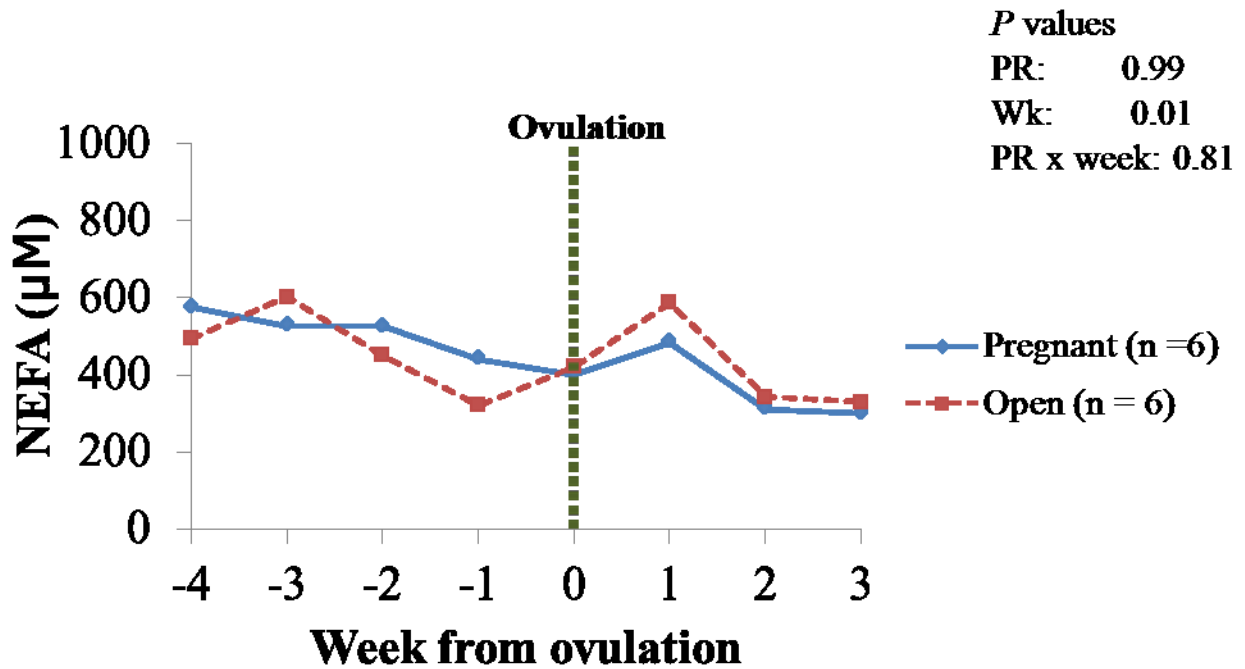

Figure 5.15.

Least squares mean (\pm SE = 84 μ M) serum concentration of non-esterified fatty acids (NEFA) during an 8-wk period encompassing the week of first postpartum ovulation according to eventual pregnancy risk (PR).

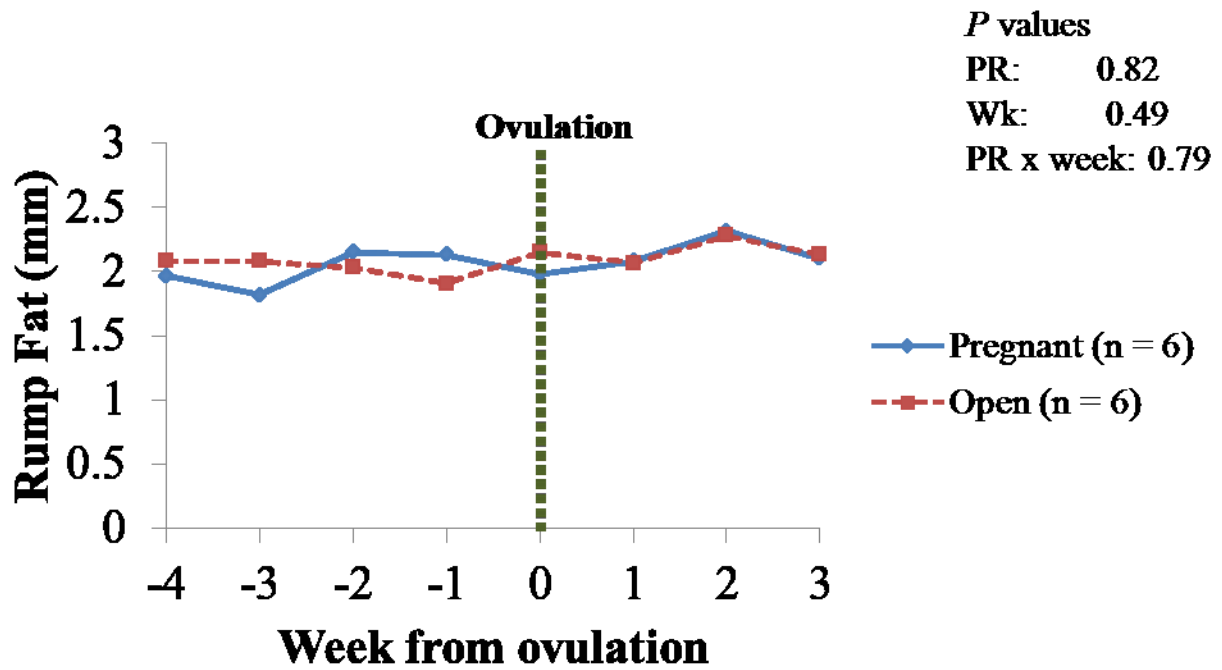

Figure 5.16.

Least squares mean (\pm SE = 0.07 mm) rump fat depth during an 8-wk period encompassing the week of first postpartum ovulation according to eventual pregnancy risk (PR).

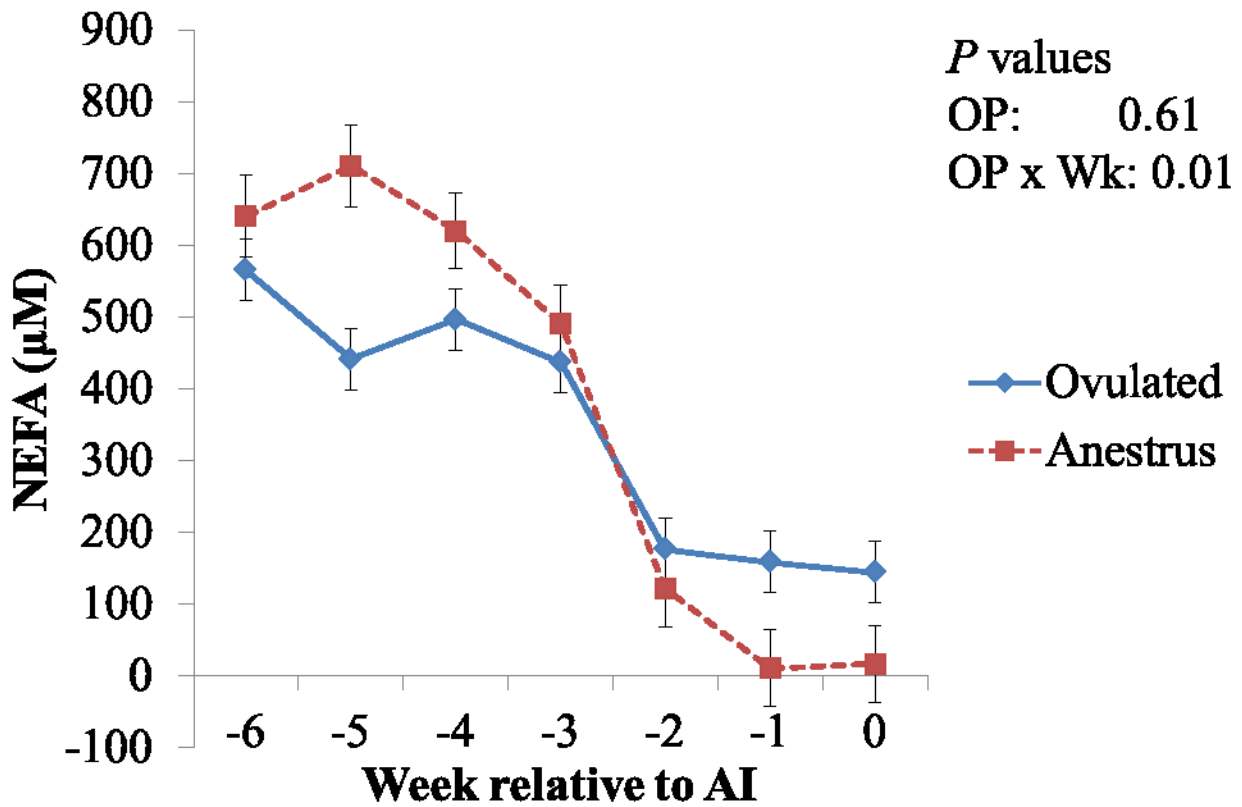

Figure 5.17.

Least squares mean weekly serum concentration of NEFA during 7 wk before the onset of a timed AI program according to pre-breeding ovulation proportion (OP).

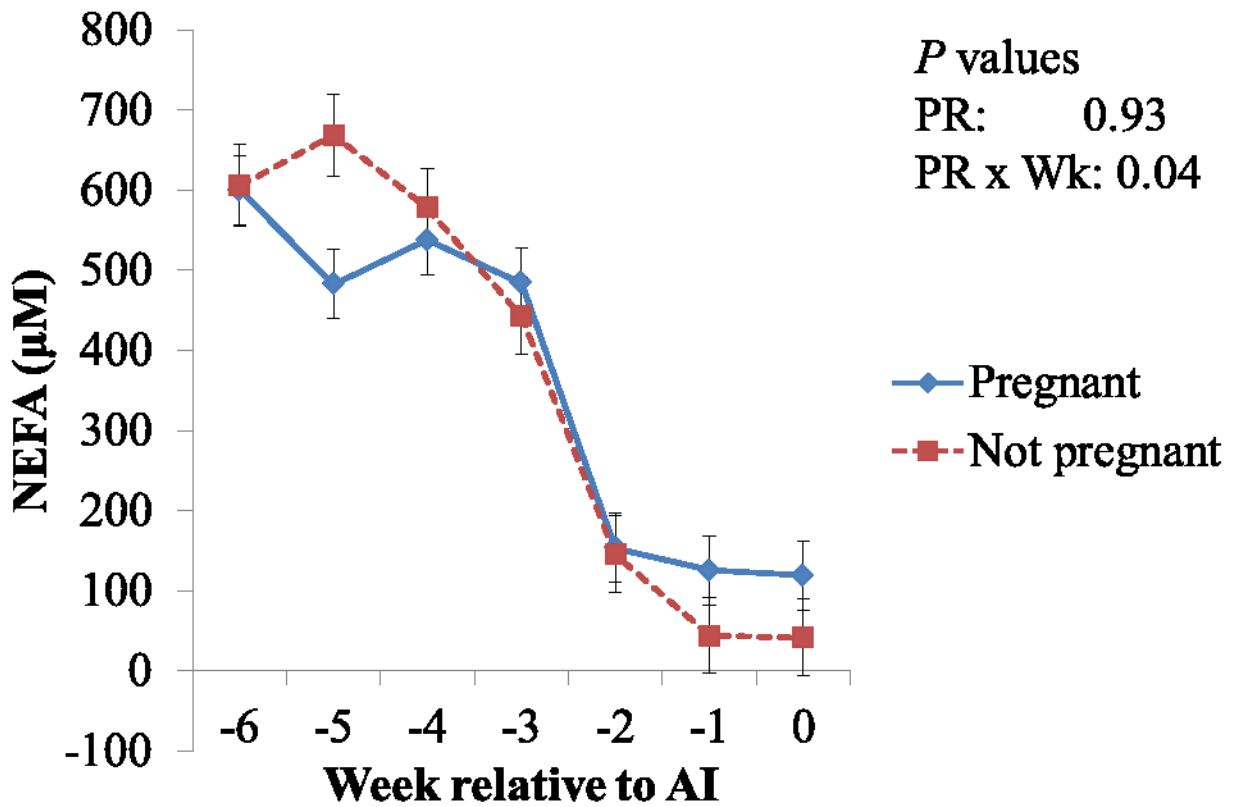

Figure 5.18.

Least squares mean weekly serum concentration of NEFA during 7 wk before the onset of a timed AI program according to pregnancy risk (PR) associated with AI.