

**Purdue University**  
**Purdue e-Pubs**

---

International High Performance Buildings  
Conference

School of Mechanical Engineering

---

2016

# A Study of the Effect of Zone Design Parameters on Frequency Domain Transfer Functions for Radiant and Convective Systems

Ali Saberi Derakhtenjani

*Concordia University, Montreal, Quebec, Canada, ali.saberi.mech@gmail.com*

Andreas K. Athienitis

*Concordia University, Montreal, Quebec, Canada, aathieni@encs.concordia.ca*

Follow this and additional works at: <http://docs.lib.purdue.edu/ihpbc>

---

Saberi Derakhtenjani, Ali and Athienitis, Andreas K., "A Study of the Effect of Zone Design Parameters on Frequency Domain Transfer Functions for Radiant and Convective Systems" (2016). *International High Performance Buildings Conference*. Paper 234.  
<http://docs.lib.purdue.edu/ihpbc/234>

This document has been made available through Purdue e-Pubs, a service of the Purdue University Libraries. Please contact [epubs@purdue.edu](mailto:epubs@purdue.edu) for additional information.

Complete proceedings may be acquired in print and on CD-ROM directly from the Ray W. Herrick Laboratories at <https://engineering.purdue.edu/Herrick/Events/orderlit.html>

## **A Study of the Effect of Zone Design Parameters on Frequency Domain Transfer Functions for Radiant and Convective Systems**

Ali Saberi Derakhtenjani<sup>1\*</sup>, Andreas K. Athienitis<sup>2</sup>

<sup>1</sup>Concordia University, building civil and environmental engineering,  
Montreal, Quebec, Canada  
ali.saberi.mech@gmail.com

<sup>2</sup>Concordia University, building civil and environmental engineering,  
Montreal, Quebec, Canada,  
aathieni@encs.concordia.ca

\* Corresponding Author

### **ABSTRACT**

This paper presents a fundamental parametric study on the effect of a number of room design parameters for radiant and convective heating sources as well as solar gains. This study is performed using frequency domain modeling approach by means of which important room transfer functions are obtained and studied. A room is considered with different types of heating (convective and radiative heating sources) and different levels of thermal mass on the floor. The effect of thermal mass and floor covering on the room thermal response considering different types of heating is investigated. The magnitude of the transfer functions between room air temperature and the convective heating source is a determining factor in the room air temperature fluctuations that affect thermal comfort. Also, in the case of radiant heating, the transfer function between room air temperature and radiant heat source can be used to determine the room air temperature swings due to the floor radiant heating source. The sensitivity of the magnitude of the transfer functions versus different values of convective and radiative heat transfer coefficients is studied and compared. This study will guide future model predictive control (MPC) research by means of frequency domain techniques to optimize key design variable such as thermal mass thickness and properties for floor heating and convective systems. It will contribute to linking building design with MPC.

### **1. INTRODUCTION**

Excessive energy consumption in buildings happens due to a number of reasons including non-optimal building design and material selections considering the building type and its energy supply systems. Energy models developed through various approaches and techniques have been used as the tools to analyze building energy consumption and to optimize their operation. Certain modeling techniques provide valuable information during early stages of design and guide us in choosing the optimum material for the building from the thermal performance point of view.

Frequency domain techniques have been shown to be a useful tool for the design analysis on a relative basis (Athienitis 1994). By means of the frequency domain modeling techniques important building transfer functions can be obtained and studied and for this usually no simulation is required. Also, it has been shown to be a practical tool for building simulation and deriving simplified grey-box building models (Saberi Derakhtenjani et al. 2015) (Wang and Xu 2006) (Xu and Wang 2007). Frequency domain techniques are especially useful for periodic analysis of phenomena inside a building. The weather-related inputs affecting energy consumption inside a building such as solar gains, exterior temperature and heating/cooling sources are cyclic phenomena and can be modeled by means of frequency domain techniques assuming periodic conditions in the calculations. These techniques can be efficiently applied to model various building-integrated energy systems (Chen et al. 2013a) (Chen et al. 2013b) and to apply control strategies (Athienitis et al. 1990) (Chen et al. 2014).

Using frequency domain techniques, the transient heat conduction inside the walls can be accurately modeled with no discretization for the thermal mass and an exact solution for 1-D heat conduction inside building envelope or wall is obtained (Athienitis and Santamouris 2002). In the case of convection and radiation heat transfer, the respective heat transfer coefficients are usually linearized in order to have a linear system of equations that can be presented by means of a linear thermal network (Athienitis and O'Brien 2014). Since convection and radiation are inherently non-linear phenomena, linearization produces some errors which are relatively significant in the case of convection between room surfaces and room air compared to the longwave radiant exchanges between surfaces. In this case, a sensitivity analysis on the magnitude of the important room transfer functions considering different values for convective and radiative heat transfer coefficients needs to be done.

## 2. METHODOLOGY

### 2.1 Frequency Domain Model

This section presents the methodology to develop frequency domain models for a room. A thermal network for a room is considered which represents the heat transfer between room surfaces and indoor and outdoor temperatures. Walls are modeled using the Norton-equivalent representation. This representation gives an exact solution for the 1-D heat conduction inside the wall (Athienitis et al. 1990). The level of detail in the thermal network depends on how radiation and convection heat transfer are modeled in the room interior zone. Combined radiative-convective heat transfer coefficients are often assumed which can be represented by a star network as shown in Figure 1.a. This network is used when there are small differences between the surfaces and room air temperature and when the heating source is mainly convective. However, in zones with high level of solar gains or in rooms with radiant heating systems, using combined heat transfer coefficients can produce significant error in the results. In those cases, convective and radiative heat transfer needs to be modeled separately (Figure 1.b). The convective and radiative coefficients are calculated as:

$$\text{convective } U_{i1} = A_1 h_{c,i}, \quad \text{radiative } U_{ij} = A_i F_{ij}^* (4\sigma T_m^3) \quad (1)$$

Where:

$A_i$  = area of surface  $i$ ,  $h_{c,i}$  = convective heat transfer coefficient of surface  $i$ ,

$F_{ij}^*$  = radiant exchange factor between surfaces  $i$  and  $j$ ,  $T_m$  = estimated mean temperature

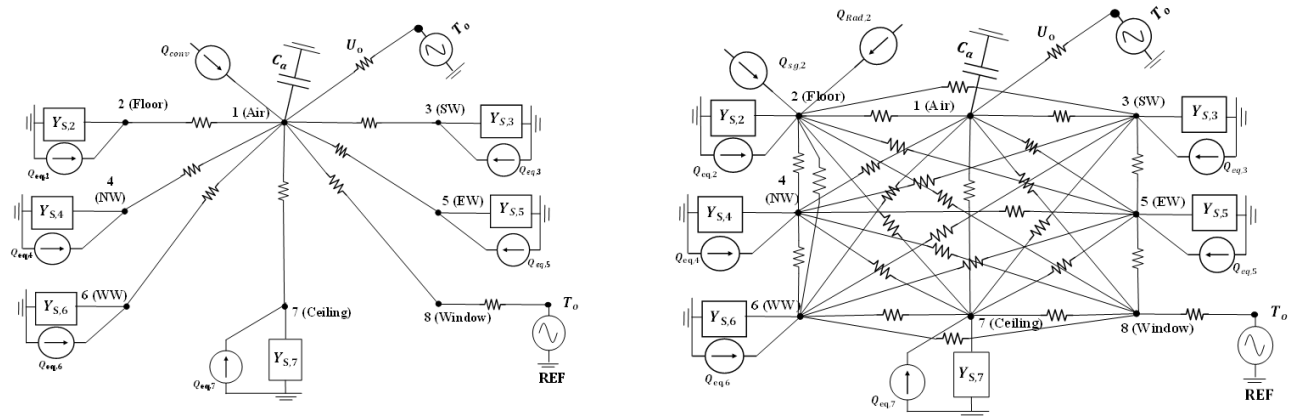

**Figure 1.** Thermal network for frequency domain considering a) combined heat transfer coefficients (left), b) separate modeling of convective and radiative exchanges (right).

In the thermal network above, all the walls and elements with thermal mass are modeled using the two-port Norton-equivalent subnetwork which consists of the wall self-admittance,  $Y_s$ , and an equivalent source,  $Q_{eq} = Y_t \times T_{ext}$ , which represents the effect of an external temperature on the surface temperature. This representation gives an exact solution for one-dimensional heat conduction inside the wall without spatial discretization. The wall self-admittance ( $Y_s$ ) and transfer admittance ( $Y_t$ ) are calculated using the following equations (Athienitis 1994):

$$Y_{s,i} = \frac{U_i + A_i k_i \gamma_i \tanh(\gamma_i l_i)}{A_i k_i \gamma_i \tanh(\gamma_i l_i) + 1}, \quad Y_{t,i} = \frac{-A_i}{\frac{A_i}{U_i} \cosh(\gamma_i l_i) + \frac{\sinh(\gamma_i l_i)}{k_i \gamma_i}} \quad (2)$$

### 2.2 Building Transfer Functions

In this section derivation of the building transfer functions for the detailed frequency domain model is presented for which the thermal network is shown in Figure 1.b. Node (1) represents the air inside the zone. Energy balance at node (1) gives:

$$C_a \frac{dT_1}{dt} + U_o(T_1 - T_o) + \sum_{J1} U_{1,J1}(T_1 - T_{J1}) = Q_{aux} \quad (3)$$

In which  $U_{1,J1}$  are the convective conductances between the air node and other surfaces ( $J1=2, 3, \dots, 8$ ),  $C_a$  is the thermal capacitance of the room air,  $T$  is temperature and  $Q_{aux}$  is the auxiliary source at the air node (which can be equal to zero). Using Laplace transform, equation (3) will be:

$$sC_a T_1(s) + U_o T_1(s) + \sum_{J1} U_{1,J1}(T_1(s) - T_{J1}(s)) = \underbrace{Q_{aux}(s)}_{Q_1} + \underbrace{U_o T_o(s)}_{Q_{eq,1}} \quad (4)$$

where  $s$  is the Laplace variable. Now, considering the floor (node (2)), the energy balance equation yields:

$$Y_{s,2}(T_2(s) - \underbrace{T_{ref}(s)}_{=0^\circ C}) + \sum_{J2} U_{2,J2}(T_2(s) - T_{J2}(s)) = \underbrace{Q_{sg,2}}_{\text{solar gain}} + \underbrace{Q_{eq,2}}_{\text{radiant source}} + Q_{rad,2} \quad (5)$$

where  $J2=1, 3, 4, \dots, 8$  and  $U_{2,J2}$  are the radiative conductances between floor and other surfaces. The energy balance for all the nodes can be written in the form below:

$$\begin{bmatrix} sC_a + \sum_j U_{1,j} + U_{inf} & -U_{1,2} & -U_{1,3} & -U_{1,4} & -U_{1,5} & -U_{1,6} & -U_{1,7} & -U_{1,8} \\ -U_{1,2} & Y_{s,2} + \sum_j U_{2,j} & -U_{2,3} & -U_{2,4} & -U_{2,5} & -U_{2,6} & -U_{2,7} & -U_{2,8} \\ -U_{1,3} & -U_{2,3} & Y_{s,3} + \sum_j U_{3,j} & -U_{3,4} & -U_{3,5} & -U_{3,6} & -U_{3,7} & -U_{3,8} \\ -U_{1,4} & -U_{2,4} & -U_{3,4} & Y_{s,4} + \sum_j U_{4,j} & -U_{4,5} & -U_{4,6} & -U_{4,7} & -U_{4,8} \\ -U_{1,5} & -U_{2,5} & -U_{3,5} & -U_{4,5} & Y_{s,5} + \sum_j U_{5,j} & -U_{5,6} & -U_{5,7} & -U_{5,8} \\ -U_{1,6} & -U_{2,6} & -U_{3,6} & -U_{4,6} & -U_{5,6} & Y_{s,6} + \sum_j U_{6,j} & -U_{6,7} & -U_{6,8} \\ -U_{1,7} & -U_{2,7} & -U_{3,7} & -U_{4,7} & -U_{5,7} & -U_{6,7} & Y_{s,7} + \sum_j U_{7,j} & -U_{7,8} \\ -U_{1,8} & -U_{2,8} & -U_{3,8} & -U_{4,8} & -U_{5,8} & -U_{6,8} & -U_{7,8} & \sum_j U_{8,j} \end{bmatrix} \begin{bmatrix} T_1 \\ T_2 \\ T_3 \\ T_4 \\ T_5 \\ T_6 \\ T_7 \\ T_8 \end{bmatrix} = \begin{bmatrix} Q_1 \\ Q_2 \\ Q_3 \\ Q_4 \\ Q_5 \\ Q_6 \\ Q_7 \\ Q_8 \end{bmatrix}$$

or

$$\mathbf{Y}_{8 \times 8} \mathbf{T}_{8 \times 1} = \mathbf{Q}_{8 \times 1}$$

Where  $\mathbf{Y}$  is the admittance matrix,  $\mathbf{T}$  is the temperature vector and  $\mathbf{Q}$  is the source vector. Elements of equation (6) are in term of the Laplace variable  $s$  and can be calculated at different frequencies ( $s=j\omega_n, j=\sqrt{-1}, \omega_n=2\pi n/p, p=24hrs, n=\text{harmonic number}$ ).

An important parameter is the impedance matrix  $\mathbf{Z}=\mathbf{Y}^{-1}$  which contains building transfer functions at different frequencies:

$$Z_{i,j} = \frac{T_i}{Q_j} \quad \rightarrow \quad Z_{1,1} = \frac{T_1}{Q_1}, \quad Z_{1,2} = \frac{T_1}{Q_2}, \dots$$

The impedance transfer function represents change in temperature of node  $i$  resulting from the effect of the source  $Q_j$  at node  $j$ . Thus, considering equation (6), temperature of node  $i$  for each frequency will be calculated as:

$$T_i = \sum_{j=1}^8 Z_{i,j} Q_j \quad (7)$$

Studying important building transfer function provides much insight into building thermal dynamics and we can evaluate design alternatives on a relative basis without detailed simulation. In the next section application of this methodology for a thermal zone is demonstrated.

### 3. MODEL APPLICATION FOR A THERMAL ZONE

#### 3.1 Description of the Thermal Zone

The thermal zone considered here in this study is a typical office room for which the dimensions are shown in Figure 2, with the walls considered to be made of gypsum board with RSI 4 insulation for each wall. The south facing façade has a 2×3m window area (two thirds of the facade area). The floor is made of concrete and represents the main thermal mass in the zone. A similar test room has been built (with different types of auxiliary systems) at Concordia University for experiments at the solar simulator /environmental chamber laboratory of Concordia University.

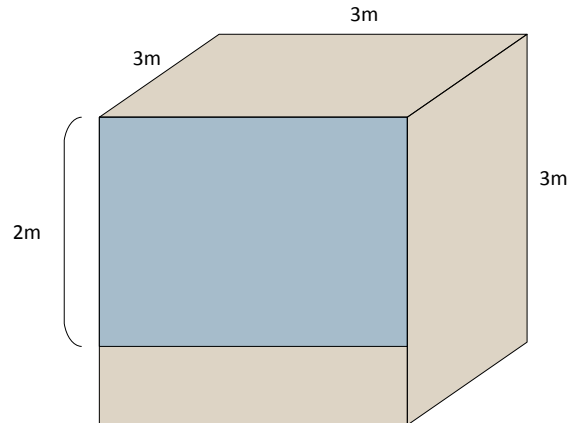

Figure 2. Room (thermal zone) geometry

A detailed frequency domain model shown in Figure 1.b is developed for the room. It is shown how important transfer functions in each case can guide us in the evaluating the dynamic behavior of the thermal zone. As an example, one of the important transfer functions is  $Z_{1,1}$  which is between the air temperature and the source at the air node. In the zones with convective heating/cooling systems this transfer function determines the impact of the convective auxiliary load on the temperature of the air in the room.

#### 3.2 Effect of Different Floor Coverings

Figure 3 shows the magnitudes of the room transfer function  $Z_{1,1}$  at different frequencies (harmonics) for two cases: 1) without any floor covering that is only concrete floor and 2) when there is a carpet covering on the floor.

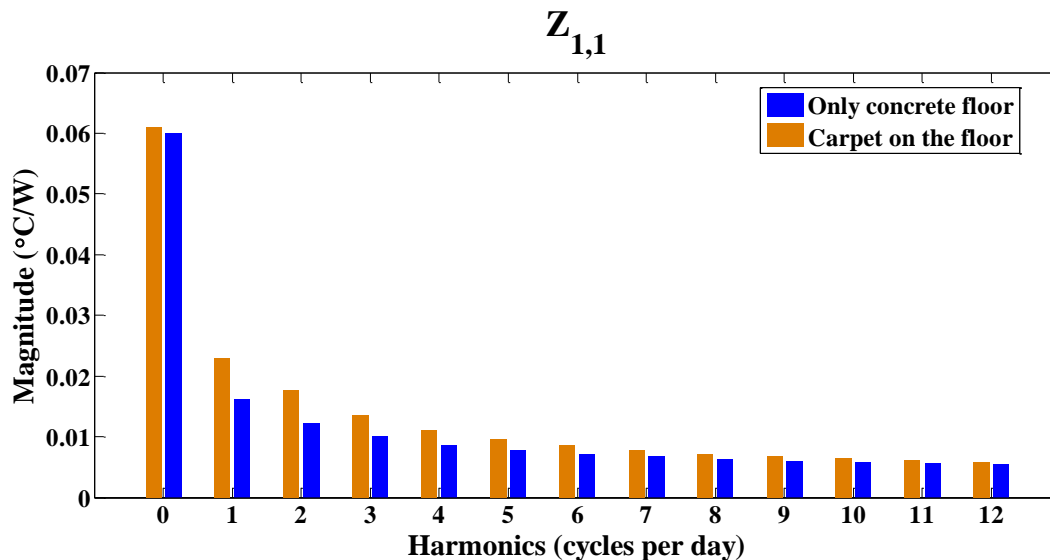

Figure 3. Comparison of the magnitude of the transfer function  $Z_{1,1}$  with and without carpet cover

As it can be observed, the magnitude of the transfer function remains at a higher value in the case of carpet compared to the original case with no carpet on the floor. This difference is especially significant for the harmonic range of 1-8 cycles per day. The higher magnitude values means that for a unique input in the air node, there will be larger room air temperature fluctuations when there is a carpet covering on the floor compared to the case of the only concrete floor. This is an important observation. If a sinusoidal excitation (an auxiliary heating source) shown in Figure 4 is inserted at the air node under a constant outdoor air temperature ( $-10^{\circ}\text{C}$ ) the following temperature profiles shown in Figure 5 are obtained for the two cases:

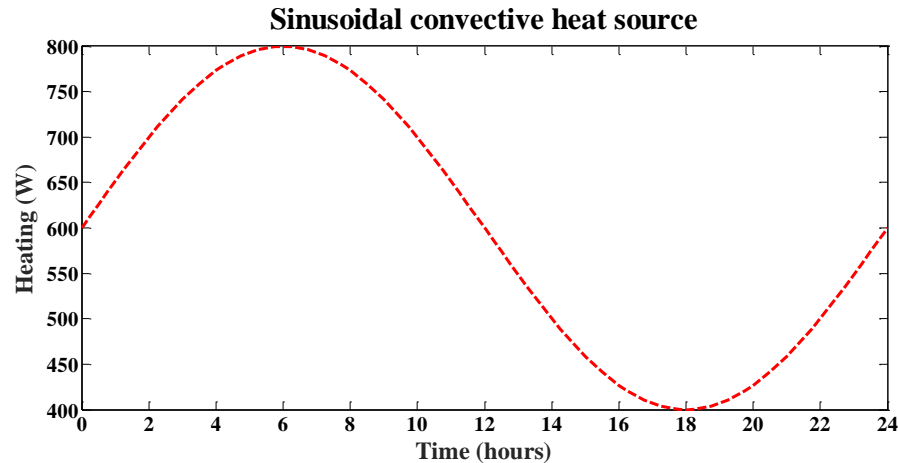

Figure 4. Auxiliary heat source profile

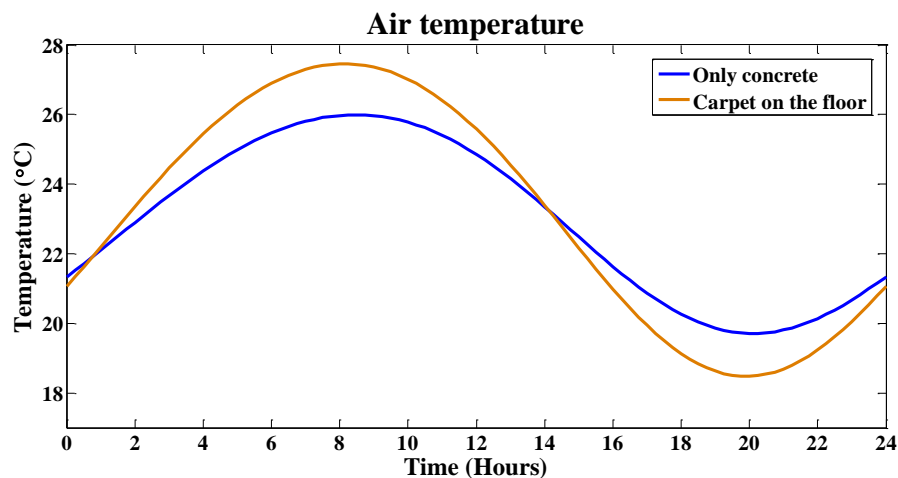

Figure 5. Air temperature profiles

As expected, larger temperature fluctuations are observed in the presence of a carpet on the floor and without carpet a more smooth temperature profile with smaller fluctuations is observed. Smaller fluctuations result in better thermal comfort in the zone. This result shows that a floor covering can have a considerable impact on the thermal performance of the zone and the occupant comfort.

### 3.3 Effect of Increasing Thermal Mass

Figure 6 shows the magnitude of the transfer function  $Z_{1,1}$  considering different thicknesses for the floor concrete. We can see that the main difference between magnitudes in different cases is for the first and second harmonics and there is not a significant difference between magnitudes for the short-term dynamics, high frequency signals. Also, we can see that in the case of the 10cm thick concrete the lowest magnitude (for the first and second harmonics) is observed for the transfer function  $Z_{1,1}$  compared to the other cases. Thus, the analysis of this chart gives us an idea for choosing an optimum concrete thickness considering different types of auxiliary systems; convective system in this case.

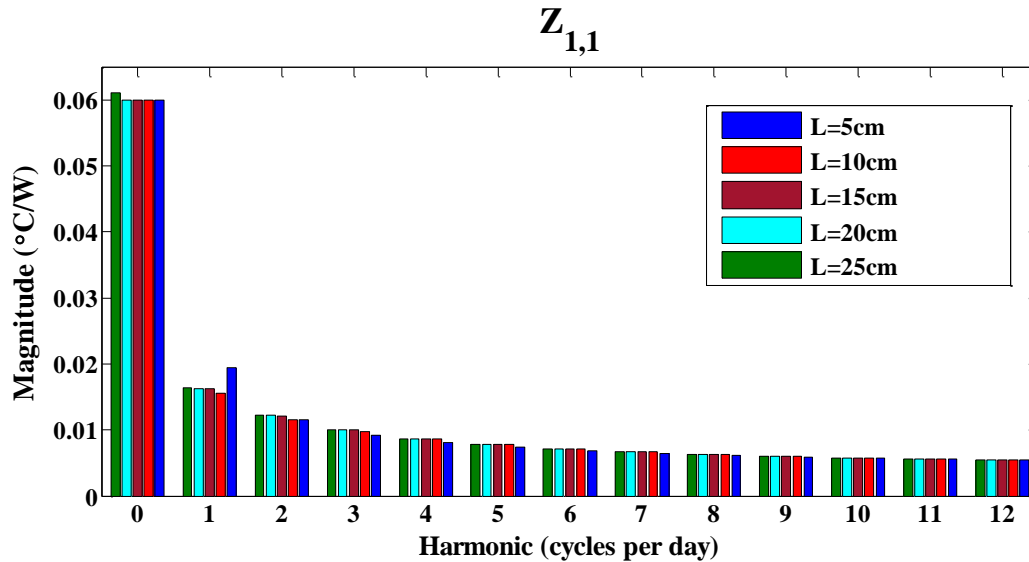

Figure 6. Comparison of transfer function  $Z_{1,1}$  magnitudes for different concrete thicknesses

Figure 7 shows magnitudes of the transfer function  $Z_{1,2}$  for a frequency range. We can observe that similar to  $Z_{1,1}$ , the significant difference is between the magnitude in the case of 5cm thick concrete with the other thicknesses for the first and second harmonics. There are no significant differences between other cases.

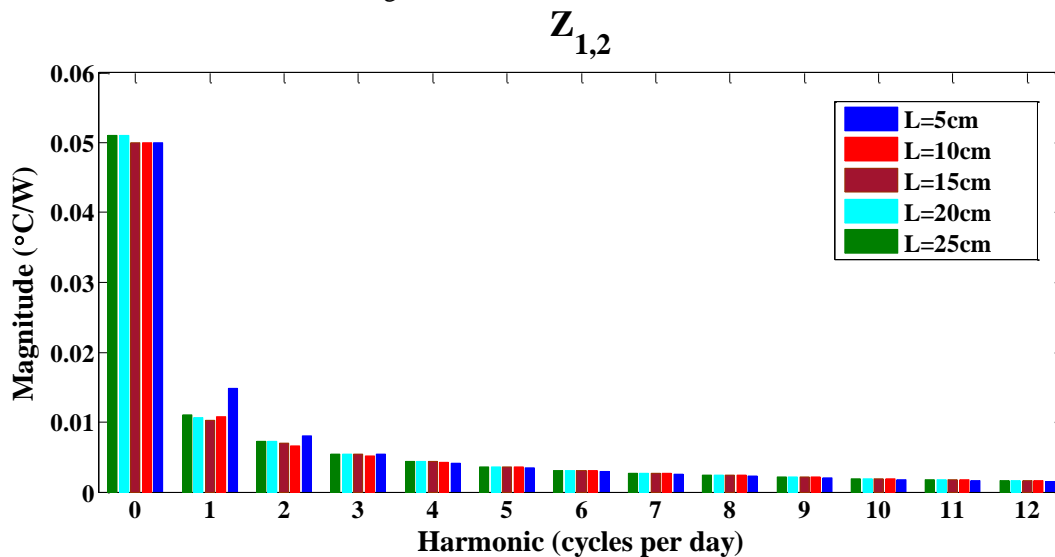

Figure 7. Comparison of transfer function  $Z_{1,2}$  magnitudes for different concrete thicknesses

### 3.4 Sensitivity Analysis of Floor Convective Heat Transfer Coefficient

Convection heat transfer is an inherently non-linear phenomenon and the respective heat transfer coefficient in a room varies significantly with temperature difference between room surfaces and the inside air. As an example for the floor, the value of the convective heat transfer coefficient can be as low as  $1\text{W}/\text{m}^2\text{K}$  for the cold floor and hot air while it can be as high as  $3.5\text{W}/\text{m}^2\text{K}$  for the hot floor and cold air. Therefore, in a room with radiant heating/cooling systems,  $h_c$  for the floor can vary a lot during a period of time. A sensitivity analysis on the magnitude of the important room transfer functions can demonstrate the thermal response of the room under different conditions.

Figure 8 shows magnitudes of the transfer function  $Z_{1,1}$  over a frequency range for different values of floor convective heat transfer coefficient ( $h_{cf}$ ). From the graph it can be observed that there is a significant difference in steady-state magnitude of the transfer function (frequency of zero) between all the cases. Also, there are noticeable differences in the magnitudes for the first, second and third harmonics which represents that the smaller the  $h_{cf}$ , the larger the

temperature fluctuations will be. Therefore, we can see that the impact of the floor convective heat transfer coefficient is quite significant.

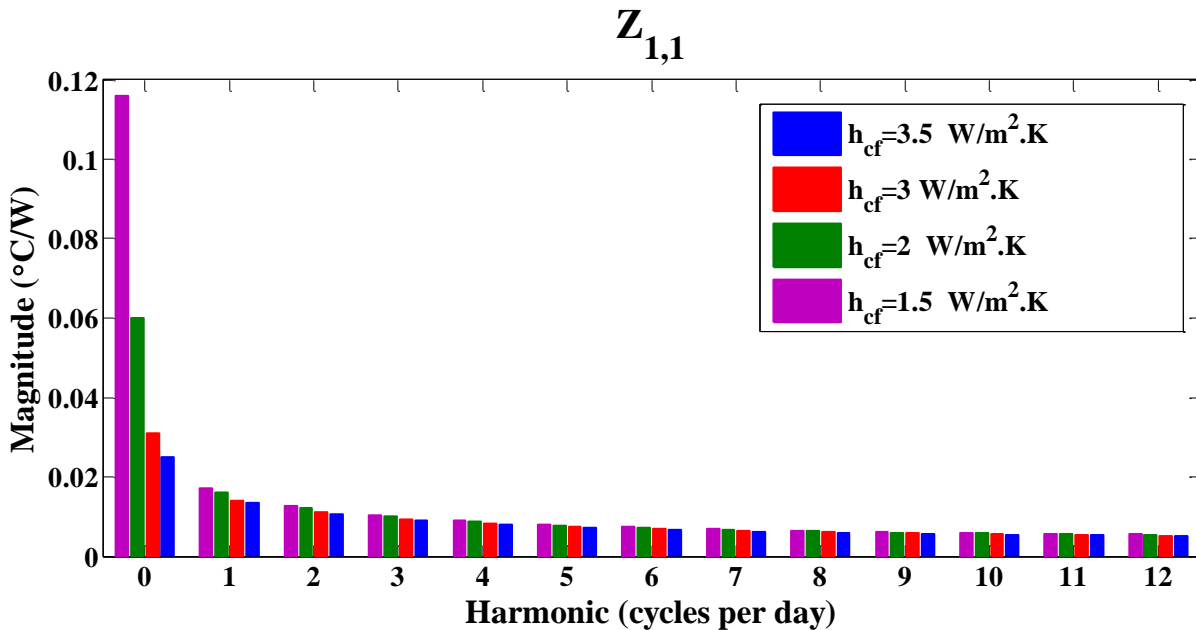

Figure 8. Sensitivity of transfer function  $Z_{1,1}$  to different values of  $h_{cf}$

a similar trend in difference between magnitudes for the transfer function  $Z_{1,2}$  is observed as well (Figure 9).

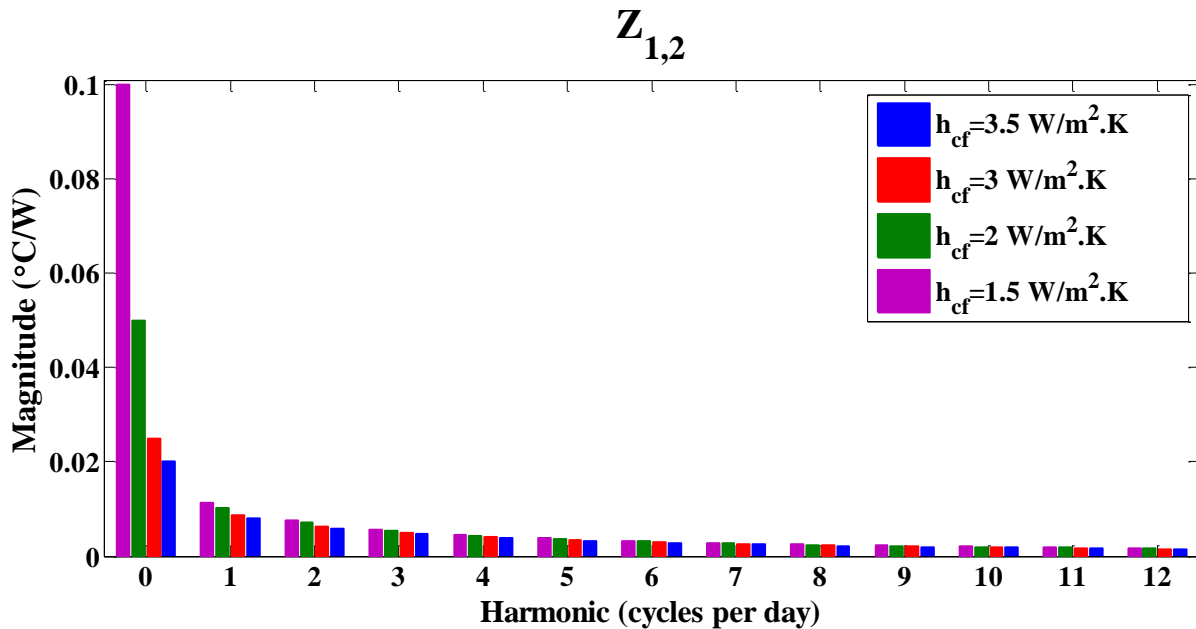
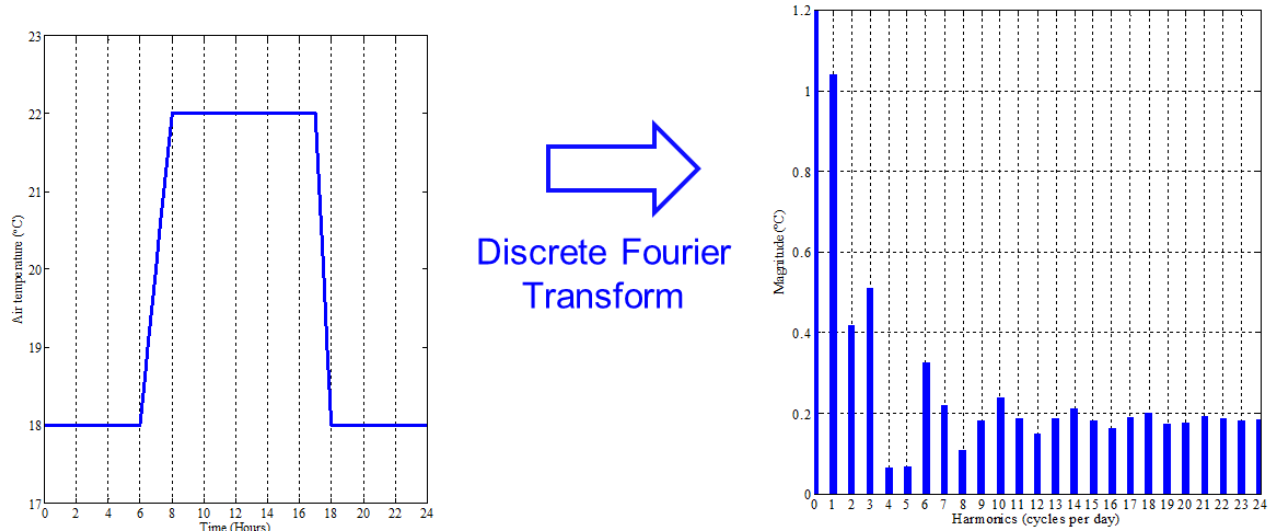

Figure 9. Sensitivity of transfer function  $Z_{1,2}$  to different values of  $h_{cf}$

### 3.5 Analysis of a room set point profile

Figure 10 shows a typical room air temperature setpoint profile with the temperature rising in the morning and a temperature setback in the evening. Using discrete Fourier transform we can see the magnitudes of this profile for different frequencies (amplitude spectrum). It is observed that the highest magnitudes of this setpoint profile are for the first, second and third harmonics.





**Figure 10.** Room air temperature setpoint profile (left) and its amplitude spectrum (right)

Also, the lowest magnitudes for the shown frequency range belongs to the fourth and fifth harmonics. Due to its specific shape, the setpoint profile has noticeable magnitudes in the frequency range of 10-24 cycles per day. Considering the room transfer function equation,  $Z \approx dT/dQ$ , it can be realized that smaller magnitudes for the transfer function in a certain frequency range lead to less fluctuations in the room temperature for the change in heat gain due to setpoint changes. Therefore, again we can observe that how analysis of the room transfer functions can guide us in evaluating different design alternatives and their impact on the room thermal performance.

With a further look in the energy balance equation of the floor (node 2) we have:

$$T_1 = \sum_{j=2}^8 Z_{1,j} Q_j = Z_{1,1} Q_1 + Z_{1,2} Q_2 + \dots + Z_{1,8} Q_8, \quad Q_2 = Q_{\text{floor}} = Q_{\text{solar}} + Q_{\text{radiant}}$$

then:

$$Q_{\text{radiant}} = \frac{T_1 - Z_{1,1}(Q_1) - Z_{1,2}(Q_{\text{solar}}) - \sum_{j=3}^8 Z_{1,j} Q_j}{Z_{1,2}} \quad (8)$$

In equation (8), the air temperature ( $T_1$ ) can be considered as a profile (setpoint) and then a radiant floor heating profile will be found to maximize the use of the floor solar gain with respect to the desired air temperature in the room.

From equation (8), it can be seen that the transfer function  $Z_{1,2}$  is a significant parameter when looking for the optimum heating or air temperature profiles. This reconfirms the significance of the room design parameters on the thermal performance of the room.

## 4. CONCLUSION

This paper presented a frequency domain analysis of the effect of the different room design parameters on the room thermal response by means of the building transfer functions. It was shown how a certain floor covering (carpet) can affect the room thermal response and increase fluctuations in the room air temperature. Also, considering different types of auxiliary systems in a room, an optimum thickness for the floor thermal mass can be found by looking at the certain transfer functions depending on the type of the auxiliary heating or cooling system used.

It was observed that floor convective heat transfer coefficient value has a very significant effect on the steady-state magnitude of the transfer functions  $Z_{1,1}$  and  $Z_{1,2}$ . In a room with a relatively hot floor compared to the inside air (floor with radiant heating system) where large values for the floor convective heat transfer coefficient are observed, the air temperature fluctuations are smaller and the more uniform air temperature will result in the better thermal comfort. Then, by means of the discrete Fourier transform (DFS), an analysis has been made on the magnitudes of a typical room air setpoint profile at different frequencies. It was explained that when the room materials are chosen so that the

room transfer functions have smaller magnitudes over a certain frequency range (over which air setpoint profile has high magnitudes), this would lead to less fluctuations in room temperature due to a change in the room heat gain. Frequency domain modeling techniques has been proven to be useful in characterizing building thermal performance. The information obtained in this study will be used in the future model-based control studies and model predictive control (MPC).

## NOMENCLATURE

$U_i$	U-value used in calculation of wall i's self and transfer admittances
$A_i$	surface area of wall i
$Y_{s,i}$	self admittance for wall i
$Y_{t,i}$	transfer admittance for wall i
$k_i$	thermal conductivity for wall i
$l_i$	thickness for wall i
$\gamma_i$	angular frequency for wall i, equal to $(s/\alpha)^{1/2}$
$C_a$	thermal capacitance of the internal air

### Subscript

s	self
t	transfer
i/j	node i/j

## REFERENCES

- Athienitis, A. K. and Santamouris, M. (2002). *Thermal analysis and design of passive solar buildings*. London, UK, James & James.
- Athienitis, A.K. (1994). *Building thermal analysis*. Boston,MA, USA, MathSoft Inc.
- Athienitis, A.K. and O'Brien, W., Eds. (2014). *Modelling, design and optimization of net-zero energy buildings* Solar heating and cooling, Berlin Ernst, Wilhelm & Sohn.
- Athienitis, A.K., Stylianou, M. and Shou, J. (1990). A methodology for building thermal dynamics studies and control applications. *ASHRAE Transactions* 96(2).
- Chen, Y., Athienitis, A. K. and Galal, Kh. (2013a). Frequency domain and finite difference modeling of ventilated concrete slabs and comparison with field measurements: Part 1, modeling methodology. *International journal of heat and mass transfer* 66: 948-956.
- Chen, Y., Athienitis, A. K. and Galal, Kh. (2013b). Frequency domain and finite difference modeling of ventilated concrete slabs and comparison with field measurements: Part 2. Application. *International Journal of Heat and Mass Transfer* 66: 957-966.
- Chen, Y., Athienitis, A. K. and Galal, Kh. (2014). A charging control strategy for active building-integrated thermal energy storage systems using frequency domain modeling. *energy and Buildings* 84: 651-661.
- Saberi Derakhtejani, Ali, Candanedo, José, Chen, Yuxiang, Dehkordi, Vahid and Athienitis, A.K. (2015). Modeling approaches for the characterization of building thermal dynamics and model-based control: A case study. *ASHRAE Science and Technology for the Built Environment* 21(6): 824-836.
- Wang, Sh. and Xu, X. (2006). Parameter estimation of internal thermal mass of building dynamic models using genetic algorithm. *Energy Conversion & Management* 47: 1921-1941.
- Xu, Xinhua and Wang, Shengwei (2007). Optimal simplified thermal models of building envelope based on frequency domain regression using genetic algorithm. *Energy and Buildings* 39(5): 525-536.

## ACKNOWLEDGEMENT

The financial and technical support of this work is provided through NSERC/Hydro-Quebec Industrial Research Chair and Concordia University. Also, technical support provided by CanmetENERGY-Varenes, Natural Resources Canada is acknowledged with thanks.