

2016

# Experimental Results on a New Prototype Packaged Heat Pump System Retrofitted with Oil Flooded Compression and Regeneration Technology

Damien Schyns

*Purdue University, School of Mechanical engineering, Ray W. Herrick Laboratories, West Lafayette, IN, USA,*  
damien.schyns@gmail.com

Bin Yang

*Purdue University, School of Mechanical engineering, Ray W. Herrick Laboratories, West Lafayette, IN, USA,*  
yang62@purdue.edu

Jim E. Braun

*Purdue University, School of Mechanical engineering, Ray W. Herrick Laboratories, West Lafayette, IN, USA,*  
jbraun@purdue.edu

W. Travis Horton

*Purdue University, School of Mechanical engineering, Ray W. Herrick Laboratories, West Lafayette, IN, USA,*  
wthorton@purdue.edu

---

Schyns, Damien; Yang, Bin; Braun, Jim E.; Horton, W. Travis; and Groll, Eckhard, "Experimental Results on a New Prototype Packaged Heat Pump System Retrofitted with Oil Flooded Compression and Regeneration Technology" (2016). *International Refrigeration and Air Conditioning Conference*. Paper 1835.  
<http://docs.lib.purdue.edu/iracc/1835>

This document has been made available through Purdue e-Pubs, a service of the Purdue University Libraries. Please contact [epubs@purdue.edu](mailto:epubs@purdue.edu) for additional information.

Complete proceedings may be acquired in print and on CD-ROM directly from the Ray W. Herrick Laboratories at <https://engineering.purdue.edu/Herrick/Events/orderlit.html>

Eckhard Groll

*Purdue University, School of Mechanical engineering, Ray W. Herrick Laboratories, West Lafayette, IN, USA,*  
groll@purdue.edu

Follow this and additional works at: <http://docs.lib.purdue.edu/iracc>

---

## Experimental results on a new prototype packaged heat pump system retrofitted with oil flooded compression and regeneration technology

Damien SCHYNS<sup>1\*</sup>, Bin YANG<sup>2\*</sup>, Jim E. BRAUN<sup>3</sup>, W. Travis HORTON<sup>4</sup>, and Eckhard A. GROLL<sup>5</sup>

<sup>1</sup>Purdue University, School of Mechanical engineering,  
Ray W. Herrick Laboratories, West Lafayette, IN, USA

<sup>1</sup>[damien.schyns@gmail.com](mailto:damien.schyns@gmail.com)

<sup>2</sup>[yang62@purdue.edu](mailto:yang62@purdue.edu)

<sup>3</sup>[jbraun@purdue.edu](mailto:jbraun@purdue.edu)

<sup>4</sup>[wthorton@purdue.edu](mailto:wthorton@purdue.edu)

<sup>5</sup>[groll@purdue.edu](mailto:groll@purdue.edu)

\* Corresponding Author

### ABSTRACT

The coefficient of performance and heating capacity of conventional air-to-air heat pumps decrease towards lower ambient temperatures. Heat pump systems are increasingly installed in residential homes but whereas they are already widespread in moderate climates, applications in very cold climates are limited. Since the heating load increases at low ambient temperatures, additional auxiliary heating systems are needed, which results in poor seasonal coefficients of performance. Oil-flooded compression is a technology to improve the performance of heat pump systems. This concept seeks to approach an isothermal compression process by injecting oil characterized by a higher specific heat than the refrigerant to absorb heat during the compression process.

In a previous study (Yang et al. 2014), a 5-ton (17.6 kW) R410A packaged heat pump retrofitted with an oil injected compressor and regenerator was tested, in which one circuit within the indoor heat exchanger was modified to serve as an oil cooler. Up to 8% COP improvement was achieved for the oil flooded system relative to the baseline system. However, the heating capacity of the oil flooded system was found to be only slightly higher (1.6% to 3.3% improvement) than the baseline system. The potential of the oil flooded compression technology was not fully achieved due to the reduced heat transfer area of the condenser and unpredictable refrigerant flow maldistribution in the evaporator. The work presented in this paper shows the experimental results of a new prototype oil flooded system. This system has a different baseline configuration than the previous oil-flooded system in which the indoor coil face area is kept unchanged while an additional heat exchanger was added as the oil cooler. In addition, a new bigger counter-flow plate heat exchanger with low pressure drops was used as the regenerator.

The results show that by injecting oil, the COP of the system was increased by 6.1% and the heating capacity by 5.7%. If the system is compared with a conventional heat pump (without regenerator and without oil injection), the COP improvement ranges from 4% to 15% depending on the oil mass fraction and operating temperature. The improvement in the heating capacity ranges from 0.4% up to 19%.

### 1. INTRODUCTION

According to the International Energy Agency (2009), residential space heating energy consumption represents 32% of the total energy used in residential buildings. Based on the current global warming concerns, several policies are set in place to reduce greenhouse gas emissions. Among others, air-source heat pumps enable a good way to reduce heating energy usage and costs while reducing greenhouse gas emissions. For instance, according to a study carried out in the United States (2014), the adoption of air-source heat pumps in homes that currently heat themselves with electric resistance could provide annual energy cost savings of approximately 1.2 billion dollars and avoid over 7 million tons of annual carbon emissions (which corresponds to the annual carbon emissions of 350,000 homes).

However, historically, air-source heat pumps have been primarily used in moderate climates and have not been very common in cold Northern climates. Indeed, the heating capacity and the coefficient of performance (COP) of conventional air-source heat pumps decrease towards lower ambient temperatures because of low evaporating temperatures. Due to low evaporating temperatures and relatively constant condensing temperatures, the pressure ratio across the compressor is high. This results in low compressor efficiency and high discharge temperatures. Moreover, at low ambient temperatures, the load increases (growing gap between the load and the available capacity of the heat pump). Therefore, auxiliary heating systems are needed for very cold climate regions. At very low ambient temperatures, the heat pump system might even shut down to protect it from very high discharge temperatures at the outlet of the compressor (the auxiliary systems must then be able to provide the entire heating requirements). This drawback results in a very poor seasonal coefficient of performance.

Among other technologies such as cascade systems or variable speed compressors, oil-flooded compression might be an alternative to increase the heating capacity and coefficient of performance of the system at low ambient temperatures. By injecting oil into both suction chambers of a scroll compressor, oil can absorb the heat generated during the compression process thanks to its high specific heat capacity. This leads to lower discharge temperatures and better sealing during the compression process. Therefore, it fixes the problem of too high discharge temperatures at very low ambient temperatures and makes a heat pump more attractive for very cold climates.

Li et al. (1992) were the first to study the working process of oil injection in scroll compressors. At that time, the aim of oil injection was to use scroll wraps without sealing elements to have a simpler structure and therefore to decrease production costs. An analytical model taking into account the radial and tangential leakages was developed and good agreement between experimental results and calculations were shown. Hiwata et al. (2002) investigated oil injection in  $CO_2$  scroll compressors in order to reduce the high leakage loss caused by the high pressure difference with  $CO_2$  compression. They developed a prototype of a  $CO_2$  scroll compressor to inject oil in the compression chambers. They studied the influence of oil injection rate on the compressor efficiency and found out that for each refrigerant flow rate, there exists an optimum oil injection rate that maximizes the efficiency of the compressor (the optimal mass fraction varies from 2 to 15%). They also suggested that the optimal oil flooding rate was a tradeoff between increased leakage at lower oil flow rate and increased suction gas preheat at high oil flow rate. Hugenroth (2006) is the first to introduce the concept of a liquid-flooded Ericsson cycle cooler, which is basically a gas Ericsson cycle heat pump. This concept uses liquid flooding of the expander and compressor to approach isothermal compression and expansion processes. Hugenroth et al. (2006) also experimentally investigated the effect of flooding with oil on the system performance for a heat pump. A possible COP improvement of up to 13% was found for heating mode. In Bell's thesis (2011), the physical background of liquid flooding and its impact on system performance was provided. Bell et al. (2011) stated that the combined technology of liquid-flooding and regeneration (between the exhaust of the condenser (refrigerant liquid) and the exhaust of the evaporator (refrigerant vapor)) could significantly increase the performances of a traditional vapor compression system. They also stipulated that the benefits of liquid-flooding and regeneration increased as the temperature lift of the system increased. Therefore, this technology is particularly well suited for cold climate heat pumps and supermarket refrigeration applications. Bell et al. (2012) determined an optimized liquid-flooded compressor through the development of a detailed compressor simulation model. They also showed that the optimal oil mass fraction increased with the pressure ratio and decreased when the suction pressure increased. Ramaraj et al. (2014) tested a R410A scroll compressor with oil-flooding. They explained that every operating condition had a maximum oil injection flow rate depending on the system pressure ratio and the dimensions of the oil injection ports. They evaluated the benefits of oil-flooding for large temperature lifts and developed a semi-empirical compressor map using the experimental results. It was stated that cooling down the oil before being injected into the compressor is important. Otherwise, the oil could not provide the cooling of refrigerant during the compression process. Recently, Yang et al. (2014) were the first to evaluate the performance of oil-flooding on a 5-ton (17.6 kW) commercial R410A packaged heat pump retrofitted with an oil-flooded compressor, regenerator and oil cooler. According to the results, the COP can be improved up to 8% compared with the baseline system. The heating capacity of the oil-flooded system was found to be only slightly higher (1.6 to 3.3% improvement). The potential of the oil-flooded compression technology was not fully achieved due to the reduced heat transfer area of the indoor heat exchanger (one circuit within the indoor heat exchanger was modified to serve as an oil cooler) and unpredictable refrigerant flow maldistribution in the evaporator.

The purpose of this paper is to present the experimental results of a new 5-ton (17.6 kW) prototype oil flooded system. This system has a different baseline configuration than the previous oil flooded system in which the indoor coil face area is kept unchanged while an additional heat exchanger is added as the oil cooler. In addition, a new bigger counter-

flow plate heat exchanger with low pressure drops is used as the regenerator. The issues of reduced heat transfer area and unpredictable flow maldistribution are eliminated by adding the additional oil cooler, which provides a greater performance improvement for the oil flooded system with regeneration than the one achieved in the previous study.

## 2. EXPERIMENTAL SETUP AND MEASUREMENTS

### 2.1 Test setup

As depicted in Figure 1, a commercial 5-ton (17.6 kW) R410A packaged heat pump system was retrofitted with an oil-flooded scroll compressor, an oil separator, a regenerator (internal heat exchanger) and an oil cooler. Although the reversible packaged heat pump is designed to run in heating mode as well as in cooling mode, it was decided to focus on the heating mode operation only. A schematic of the retrofitted heat pump can be found in Figure 2. The schematic can be divided into two separate loops: oil loop and refrigerant loop.

For the refrigerant loop, the superheated vapor is compressed from the evaporating pressure to the condensing pressure in the compressor. After compression, the two-phase mixture (oil and refrigerant) is separated inside the oil separator. Then, the refrigerant passes through the reversing valve and goes into the indoor unit where it rejects heat to the indoor air flow. At the outlet of the indoor unit, the refrigerant is subcooled and flows through the Thermostatic Expansion Valve (TXV), which works as a straight tube in heating mode. The fluid is then further subcooled in the regenerator before flowing through the mass flow meter and filter-dryer. Afterwards, the refrigerant is expanded to the evaporating pressure through an Electronic Expansion Valve (EXV2) and two parallel piston expansion valves (fixed orifice valves). Compared with the baseline system, this EXV2 has been added to the commercial packaged heat pump in order to control the superheat at the outlet of the evaporator. After the expansion devices, the low-pressure two-phase mixture is evaporated and superheated in the outdoor unit. At the outlet of the evaporator, the fluid passes through the regenerator to be further superheated by heat transfer with the subcooled liquid refrigerant flow. The flow then passes through the reversing valve and accumulator, and goes back to the compressor suction.

In the oil loop, the oil is injected into the scroll set at the inlet of both suction chambers. After compression, the oil is separated from the refrigerant in the oil separator (there is still a small amount of refrigerant in the oil due to the solubility of refrigerant into oil). Then, the oil is cooled down in the oil cooler by heat transfer with the indoor air flow. The liquid oil passes through the oil mass flow meter and is expanded in the Electronic Expansion Device (EXV1) before going back to the compressor.

As can be seen in Figure 2, a solenoid valve has been placed before the EXV1. It is directly connected to the power consumption of the compressor. If the compressor is running, the solenoid valve is open. Otherwise, it is closed. Its aim is to close the oil loop when the system is not running and to prevent the migration of oil from the top of the system to the bottom of the system by gravity.

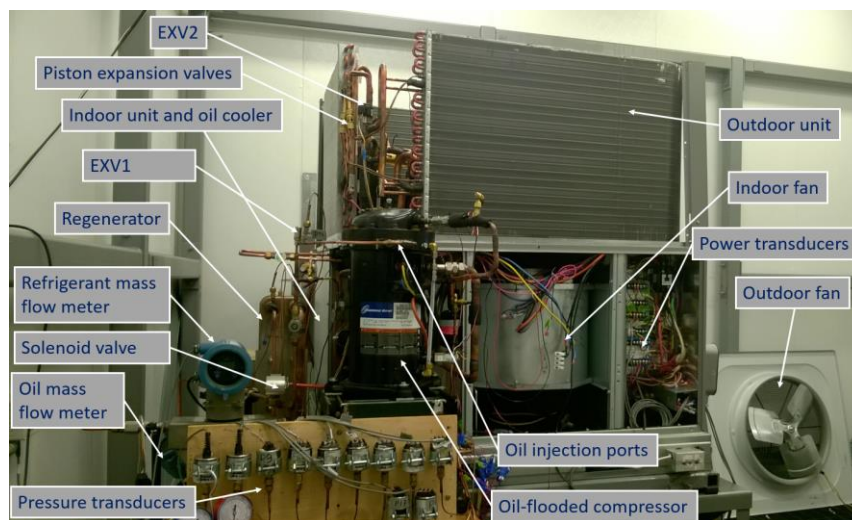

**Figure 1:** Experimental setup

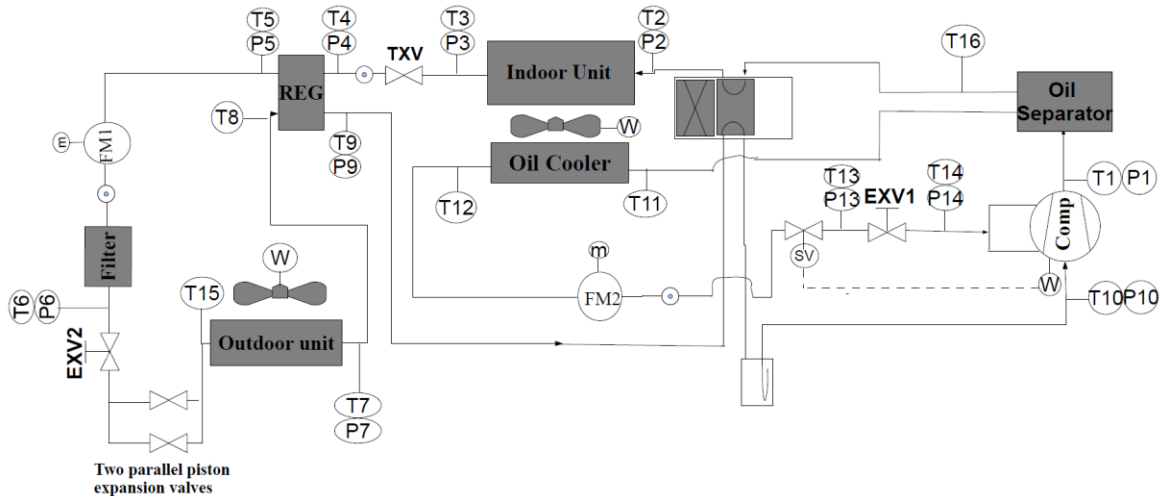

**Figure 2:** schematic of a packaged heat pump using oil-flooded compression with regeneration technology

## 2.2 Test matrix

The modified heat pump was tested in psychrometric chambers in order to fully understand the effect of oil-flooded compression with regeneration on system performance in heating mode. The test matrix used for this test stand was inspired by the AHRI Standard 210/240. Since there is no standard for oil-flooded systems, a test matrix with different oil mass fractions was created and is presented in Table 1. In order to investigate the impact of oil mass fraction on the system performance, the oil mass fraction varies for each test from 0.0 to 0.3, in 0.05 intervals. The oil mass fraction is defined by:

$$x_o = \frac{\dot{m}_o}{\dot{m}_o + \dot{m}_r} \quad (1)$$

**Table 1:** Test matrix for oil-flooded heat pump in heating mode

Test *	Air entering the indoor unit			Air entering the outdoor unit			Indoor air flow rate	
	T [°F]	T [°C]	RH [%]	T [°F]	T [°C]	RH [%]	CFM	[m <sup>3</sup> /s]
H1	70	21.1	≤ 56.03	47	8.33	72.64	1750	0.826
H2	70	21.1	≤ 56.03	35	1.67	81.80	1750	0.826
H3	70	21.1	≤ 56.03	17	-8.33	69.41	1750	0.826
H4	70	21.1	≤ 56.03	0	-17.78	min	1750	0.826

\* For every test in heating mode, the oil mass fraction varies from 0.0 to 0.30, in 0.05 intervals.

The following comments about the test matrix can be made:

- In the AHRI Standard 210/240, the H4 test is missing. As oil-flooding is particularly interesting for low temperature applications, a very low temperature test (H4 test) has been added to the test matrix so as to evaluate the performance at these conditions.
- For the indoor unit, the relative humidity must be below 56.03%. Since the value is not imposed, a fixed set point of 50% has been chosen.
- For the H4 test, the relative humidity in the outdoor room is set to minimum.

## 3. RESULTS AND DISCUSSION

To evaluate the performance of the heat pump equipped with the oil-flooded compressor and regenerator (see Figure 2), steady-state experimental data were recorded for each test listed in the test matrix<sup>1</sup>. The superheat at the outlet of

<sup>1</sup> For tests H2, H3 and H4, the maximum oil mass fraction was limited to 0.25 by the system, therefore no data are available for an oil mass fraction of 0.3. For test H1, the oil mass fraction was limited to 0.2

the evaporator was controlled by EXV2 at a value of 5°C for every test. Steady state was maintained for at least 30 minutes for every test condition. The recorded data were then processed in order to evaluate the performance of the system. A total of 33 experimental points were obtained: 23 for the test matrix, 6 additional points at higher superheat for evaluating the influence of superheat and the last 4 points for determining system performance both without the regenerator and oil injection.

### 3.1 Oil-flooded compression

Figure 3 to 8 show the performance of the oil-flooded compressor for different outdoor room temperatures, a fixed indoor room temperature (21.11°C) and a fixed superheat of 5°C at the outlet of the evaporator. The isentropic efficiency of the compressor must account for the effect of oil injection and is defined by:

$$\varepsilon_{is,cp} = \frac{\dot{m}_r \cdot (h_{r,ex,cp,is} - h_{r,su,cp}) + \dot{m}_o \cdot (h_{o,ex,cp,is} - h_{o,su,cp})}{\dot{W}_{cp}} \quad (2)$$

where  $\dot{m}_r$  and  $\dot{m}_o$  are the mass flow rate of refrigerant and oil, respectively,  $\dot{W}_{cp}$  is the compressor power consumption,  $h_{r,ex,cp,is}$  and  $h_{o,ex,cp,is}$  are respectively the enthalpies at the compressor discharge with an isentropic compression between suction and discharge. Figure 3 shows that the isentropic efficiency has a maximum for an oil mass fraction of approximately 0.1 at a given outdoor room temperature. The increase of the isentropic efficiency at low oil mass fraction is most likely due to reduced internal leakage and friction. The decrease at higher oil mass fraction might be due to different reasons: higher pressure drops through suction and discharge ports due to oil injection, higher pressure drops through the compression process due to the oil viscosity, higher power consumption used to pump the oil from low pressure to high pressure and more irreversibilities in the two-phase flow (such as non-homogeneous equilibrium). The isentropic efficiency is also higher at higher outdoor air (ambient) temperatures mainly because the refrigerant mass flow rate is higher, the electromechanical losses are lower and the built-in volume ratio is more suited to the pressure ratio of the system (lower over-compression at higher outdoor temperatures, i.e. the external pressure is too high at low outdoor room temperature).

The volumetric efficiency of the compressor is calculated according to the following expression (Ramaraj et al. 2014):

$$\varepsilon_{vol,cp} = \frac{\dot{m}_r + \dot{m}_o}{\rho_{m,su,cp} \cdot \dot{V}_{s,cp}} \quad (3)$$

where the volume flow rate and the inlet mixture density are given by:

$$\dot{V}_{s,cp} = V_{s,cp} \cdot N_{rot,cp} \quad (4)$$

$$\rho_{m,su,cp} = \frac{(1 - x_o) + S \cdot x_o}{(1 - x_o) \cdot v_r + S \cdot x_o \cdot v_o} \quad (5)$$

and where  $v_r$  and  $v_o$  are the specific volume of refrigerant and oil, respectively, and  $S$  is the slip ratio, which was taken to be 1 (i.e., a homogeneous two-phase flow). As can be seen in Figure 3, the volumetric efficiency increases with the oil mass fraction and seems to stabilize at higher oil mass fraction. This increase is probably due to lower internal leakage. For instance, the volumetric efficiency between  $x_o = 0$  and  $x_o = 0.25$  increases by 6.64% at  $T_{out} = -17.78^\circ\text{C}$ .

As expected (see Figure 5), the discharge temperature decreases when oil is injected, the temperature difference between no oil injection and  $x_o = 0.25$  is around 35-40°C depending on the outdoor room temperature. Moreover, at a given oil mass fraction, the discharge temperature increases slightly when the outdoor room temperature decreases. However, a higher increase could have been expected. This slight increase could be explained by two opposing effects. On one hand, the pressure ratio increases when the outdoor room temperature decreases, which tends to increase the temperature difference between suction and discharge temperature. On the other hand, the compressor suction temperature decreases at lower outdoor room temperature, which limits the discharge temperature. The lower suction temperature is mainly due to lower temperatures at the inlet of the regenerator (high pressure side, T4 in Figure 2) because of lower condensing temperatures at low outdoor temperatures. The lower suction temperature leads to lower superheat at the outlet of the regenerator (low pressure side, T9 in Figure 2). Beside this observation, Figure 6 shows that the compressor temperature ratio (between discharge temperature and suction temperature) is significantly higher at lower outdoor room temperature and a more isothermal compression is achieved when the oil mass fraction increases.

As can be seen in Figure 7, the refrigerant mass flow rate tends to increase with oil injection. It is probably due to lower internal leakage. It can also be due to lower temperatures in the suction chamber (i.e. higher density and therefore higher mass flow rate). The refrigerant mass flow rate also increases with the outdoor air temperature because of higher density at the suction (since the evaporating pressure is higher).

Regarding the compressor power consumption (see Figure 8), no general trends can be pointed out. Indeed, for  $T_{out} = 8.33^\circ\text{C}$  and  $T_{out} = 1.67^\circ\text{C}$ , a minimum is reached for an oil mass fraction of approximately 0.1. At low oil mass fraction, the power consumption decreases due to the sealing properties of oil and the higher isentropic and volumetric efficiencies of the compressor. At higher oil mass fraction, the opposite effect occurs since the isentropic efficiency decreases. However, at lower temperature, the same trends cannot be pointed out. For  $T_{out} = -8.33^\circ\text{C}$ , the power consumption decreases until  $x_o = 0.25$  and for  $T_{out} = -17.78^\circ\text{C}$ , a maximum is reached around  $x_o = 0.05$  and then it decreases.

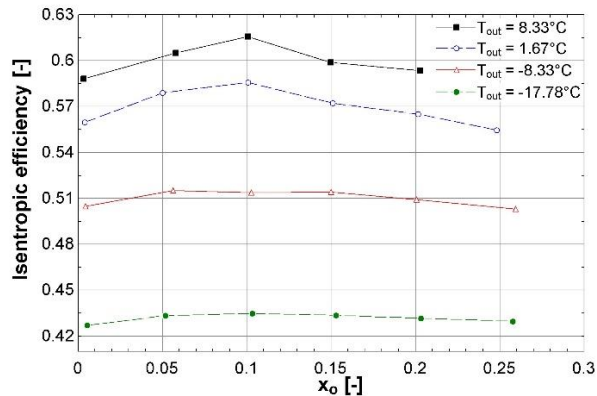

Figure 3: Isentropic efficiency of the compressor

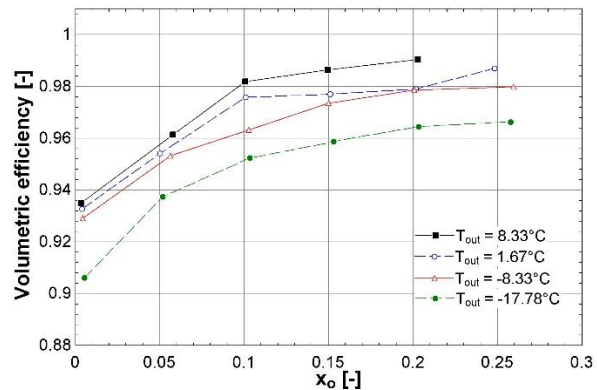

Figure 4: Volumetric efficiency of the compressor

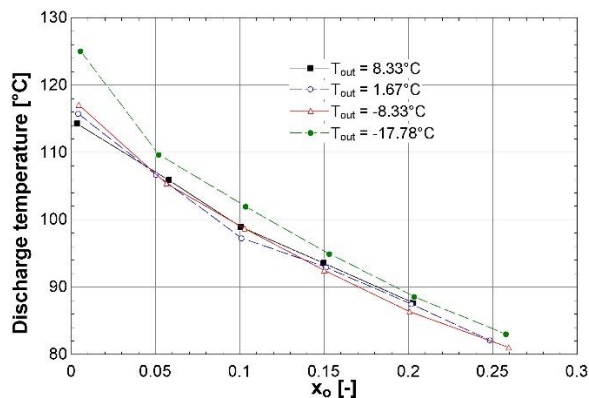

Figure 5: Compressor discharge temperature

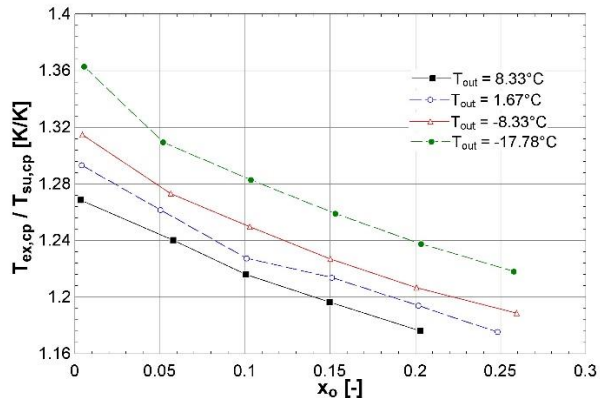

Figure 6: Compressor temperature ratio



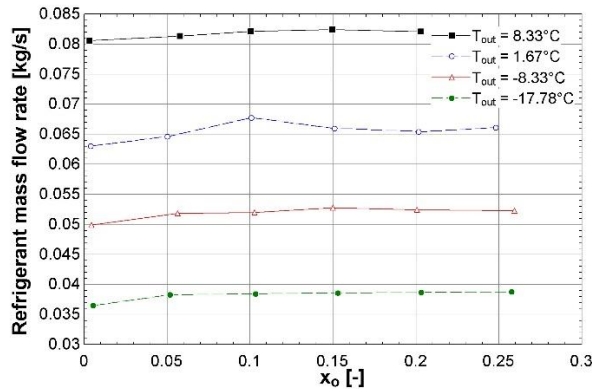

Figure 7: Refrigerant mass flow rate

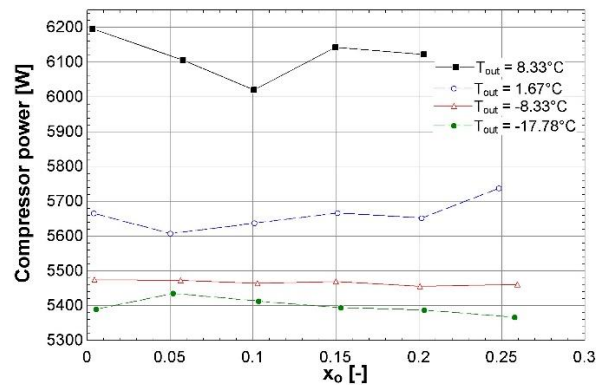

Figure 8: Compressor power

### 3.2 Heat pump performance

The coefficient of performance of the heat pump in the absence of auxiliary heat is given by:

$$COP = \frac{\dot{Q}_a}{\dot{W}_{cp} + \dot{W}_{in,fan} + \dot{W}_{out,fan}} \quad (6)$$

where  $\dot{W}_{in,fan}$  and  $\dot{W}_{out,fan}$  are the indoor and outdoor fan power consumption, respectively, and  $\dot{Q}_a$  is the heating capacity calculated on the air side. The air-side capacity should also be equal to the sum of the oil cooler capacity, the condenser capacity and the indoor fan power consumption:

$$\dot{Q}_a = \dot{Q}_{o,oc} + \dot{Q}_{r,cd} + \dot{W}_{in,fan} \quad (7)$$

where  $\dot{Q}_{o,oc}$  is the heat transfer rate in the oil cooler (oil side) and  $\dot{Q}_{r,cd}$  is the heat transfer rate in the condenser (refrigerant side).

Figure 9 shows the effect of oil mass fraction on heating capacity for various outdoor temperatures and a fixed indoor room temperature ( $21.11^\circ\text{C}$ ). It reaches a maximum around  $x_o = 0.10 - 0.15$  at high outdoor air temperatures ( $8.33^\circ\text{C}$  and  $1.67^\circ\text{C}$ ) and does not reach a maximum even for  $x_o = 0.25$  at lower temperatures ( $-8.33^\circ\text{C}$  and  $-17.78^\circ\text{C}$ ). The increases in maximum capacity due to oil injection compared to  $x_o = 0$  are: 1.2% for  $T_{out} = 8.33^\circ\text{C}$  at  $x_o = 0.15$ , 5.0% for  $T_{out} = 1.67^\circ\text{C}$  at  $x_o = 0.1$ , 4.3% for  $T_{out} = -8.33^\circ\text{C}$  at  $x_o = 0.25$  and 5.7% for  $T_{out} = -17.78^\circ\text{C}$  at  $x_o = 0.25$ . At a given outdoor temperature, the condensing temperature does not have a significant dependence on oil mass fraction. When the oil mass fraction is increased, the refrigerant mass flow rate tends to increase (see Figure 7), which increases the capacity. But at the same time, the superheat at the inlet of the condenser decreases (which decreases the capacity) because the discharge temperature of the compressor decreases. However, when the oil mass fraction increases, the cooling of oil increases as well, which increases the capacity since more oil is cooled down by the air flow (i.e. the oil cooler capacity is increased). Overall, these opposing effects result in an increase of heating capacity when oil mass fraction is increased.

For the COP, the same trends can be pointed out (see Figure 10). For  $T_{out} = 8.33^\circ\text{C}$  and  $T_{out} = 1.67^\circ\text{C}$ , the COP increases as the oil mass fraction is increased and reaches a maximum for  $x_o = 0.1$  before decreasing. The increases in maximum COP associated with oil injection compared to no oil injection are 3.3% and 5.6% for  $T_{out} = 8.33^\circ\text{C}$  and  $T_{out} = 1.67^\circ\text{C}$ , respectively. The increase in COP with oil mass fraction at low values is because the capacity increases (see Figure 9) and the compressor power consumption decreases (see Figure 8). At higher oil mass fractions, the opposite effect occurs: compressor power consumption increases whereas capacity decreases. At lower outdoor air temperatures ( $T_{out} = -8.33^\circ\text{C}$  and  $T_{out} = -17.67^\circ\text{C}$ ), the COP also increases with oil injection but a maximum is not reached, even for  $x_o = 0.25$ . This is consistent with the trends that there is no minimum for the compressor power consumption (see Figure 8) and no maximum for the capacity (see Figure 9) over the range of oil mass fractions tested. The COP improvements for oil flooding over no flooding (i.e., between  $x_o = 0$  and  $x_o = 0.25$ ) are 4.5% and 6.1% for  $T_{out} = -8.33^\circ\text{C}$  and  $T_{out} = -17.67^\circ\text{C}$ , respectively.

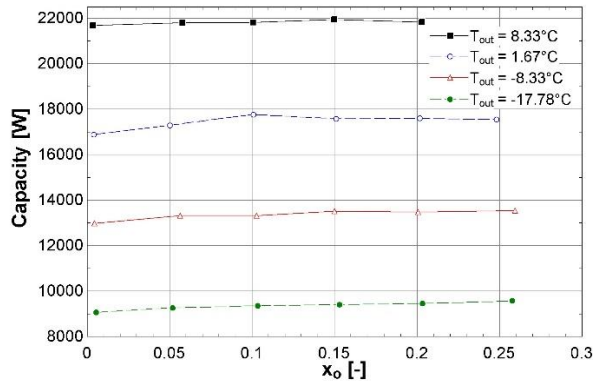

Figure 9: Heating capacity of heat pump

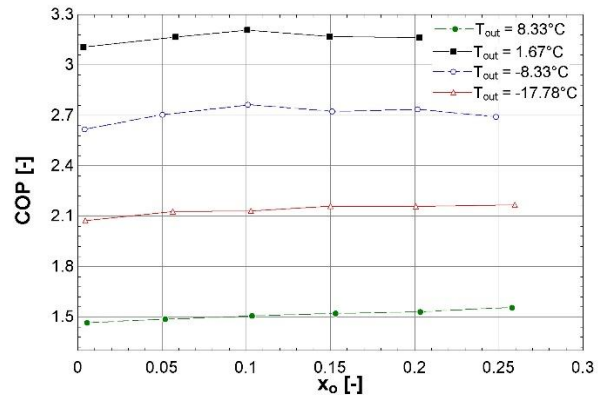

Figure 10: COP of heat pump

### 3.3 Influence of superheat

Experimental data were recorded at 8.33°C (outdoor temperature) for two different superheats at the outlet of the evaporator: 5°C and 10°C. Figures 11 and 12 show the influence of variations in superheat on COP and heating capacity. It can be seen that the influence is high. Indeed, the COP is decreased by 0.5 (i.e. a decrease of around 15%) between 5°C and 10°C superheat and the heating capacity is decreased by more than 4000 W (i.e. a decrease of around 20%) between 5°C and 10°C superheat. This high influence is due to a large decrease in evaporating temperature (it decreases from -3°C at 5°C superheat to -11°C at 10°C superheat). Indeed, it seems that this lower evaporating temperature hurts the performance much more than the superheat. It must be pointed out that the capacity is mainly decreased by the refrigerant mass flow rate that decreases from 0.08 kg/s to 0.06 kg/s between -3°C and -11°C evaporating temperature. The opening of the EXV2 (see Figure 2) was approximately 40% open for 5°C superheat and only 25% open for 10°C superheat. The expansion valve opening of 25% lowered the evaporating pressure to balance the flow through its constriction.

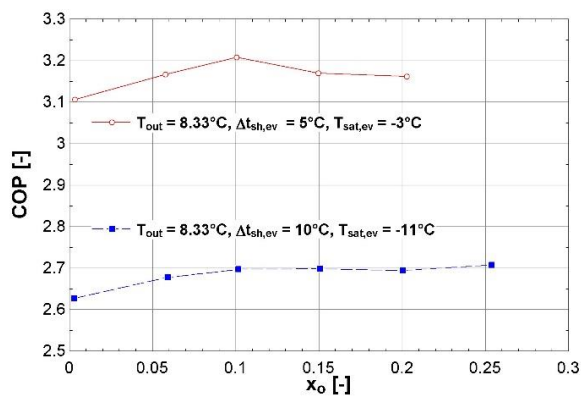

Figure 11: Influence of superheat on COP

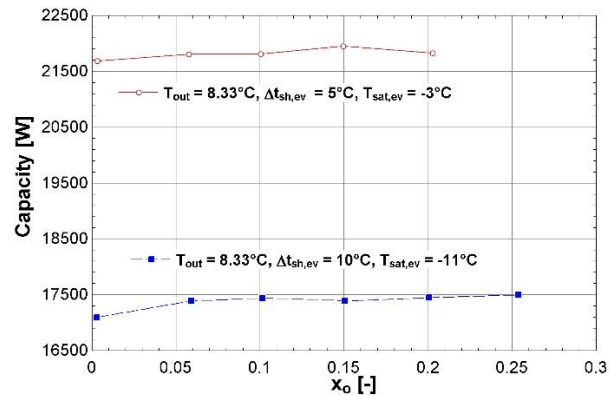

Figure 12: Influence of superheat on heating capacity

### 3.4 Comparison with a conventional heat pump system

In order to compare the performance of the oil-flooded system with regeneration to that of a conventional heat pump system, some tests were run without the regenerator and without oil injection in the oil-flooded compressor. The results obtained with this baseline system were then used to identify the performance improvement by oil-flooding and regeneration. To compare these two systems, the COP improvement is defined as follows:

$$COP_{imp} = \frac{COP_{oil-flooded} - COP_{baseline}}{COP_{baseline}} \quad (8)$$

where  $COP_{oil-flooded}$  is the COP of the oil-flooded system with regeneration and  $COP_{baseline}$  is the COP of the baseline system (without oil injection and without regeneration). An analogous expression is used for the heating capacity improvements. Using the 4 experimental points available for the conventional heat pump (one point for each

outdoor room temperature of the test matrix) and the 23 experimental points available for the heat pump with oil-flooding, the results of Figure 13 and 14 were generated to show the COP and capacity improvements as a function of oil mass fraction. The COP improvements range between 4% and 15% and the capacity improvements are between about 1% and 19%. Most of the experimental points are characterized by a superheat of 5°C at the outlet of the evaporator. However, it must be pointed out that for the baseline system, the test at  $T_{out} = 8.33^\circ\text{C}$  was carried out with a superheat of 7.5°C (instead of 5°C) at the outlet of the evaporator because without the regenerator, the system could not reach the lower superheat even with the EXV2 fully open (see Figure 2). As explained in previous section, the superheat influences the performance. Therefore, this explains why the capacity and COP improvements are greater for  $T_{out} = 8.33^\circ\text{C}$ . Therefore, the results for the other three operating temperatures are more meaningful and are the focus of additional analysis and discussion.

The three points without oil injection (i.e.  $x_o = 0$  in Figure 13 and 14) are analyzed first. It can be seen that even without oil injection, the COP increases (between 4 and 8%) between the conventional heat pump and the heat pump with regeneration, which clearly shows the benefit of the regenerator. Several factors directly or indirectly influence the higher COP with regeneration:

- The condensing temperature is slightly lower (by approximately 2°C) and the evaporating temperature slightly higher with regeneration. Therefore, the pressure ratio is lower with the regenerator.
- The compressor power consumption is lower (by approximately 200 W) with the regenerator. This is due to both a lower refrigerant mass flow rate and a lower pressure ratio through the compressor.
- The heating capacity is higher with regeneration (see Figure 14). The capacity increases with regeneration because the superheat at the inlet of the condenser is higher due to a higher superheat at the inlet of the compressor. However, two opposite effects decrease the capacity: the refrigerant flow rate and the condensing temperature are lower with the regenerator. But in general, the heating capacity was increased for the cases considered.

When oil is injected into the compressor of the system with regeneration, the maximum COP is reached at  $x_o = 0.1$  and the COP improvement is 10.3% for  $T_{out} = 1.67^\circ\text{C}$ . For the two lowest outdoor temperatures, the maximum COP is not reached even for an oil mass fraction of  $x_o = 0.25$ . At this oil mass fraction, the COP improvements are 13.3% and 14.3% at outdoor temperatures of  $-8.33^\circ\text{C}$  and  $-17.78^\circ\text{C}$ , respectively.

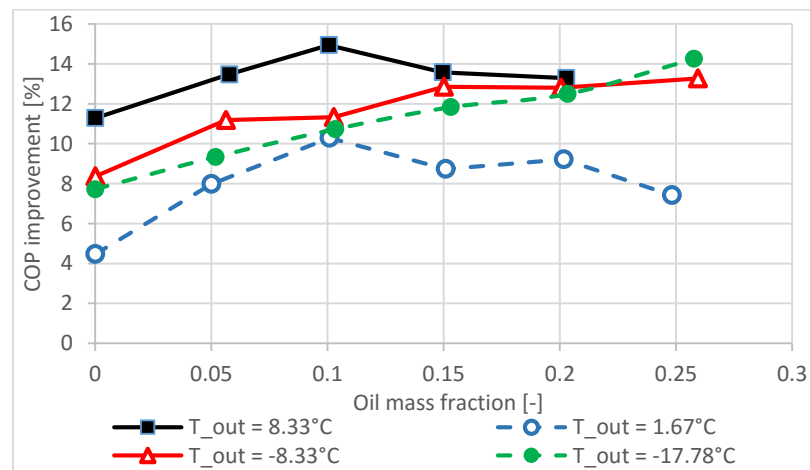

**Figure 13:** COP improvement between oil-flooded system with regeneration and baseline system

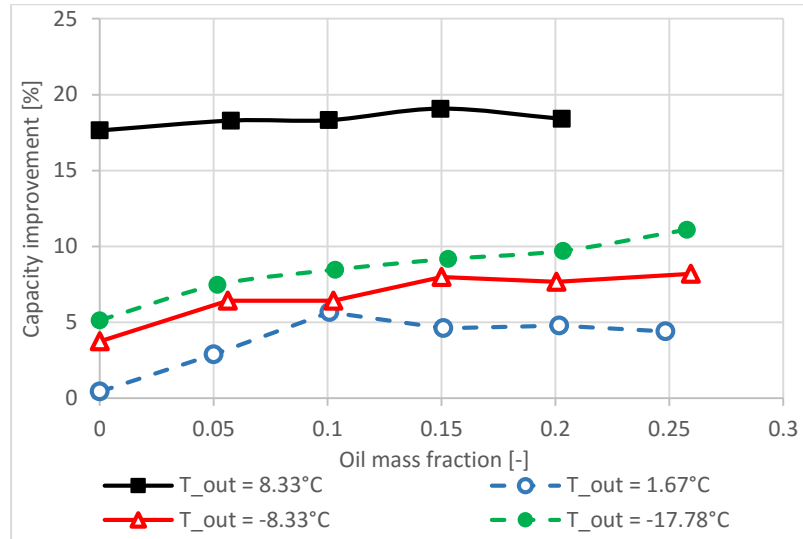

**Figure 14:** Capacity improvement between oil-flooded system with regeneration and baseline system

## 6. CONCLUSIONS AND FUTURE WORK

Applications of heat pump systems in cold climates are limited mainly due to a decrease of the heating capacity and the coefficient of performance towards low ambient temperatures, which results in very poor seasonal coefficient of performance. In this paper, a prototype heat pump system retrofitted with oil-flooded compression and regeneration technology was tested. Results show that:

- The isentropic efficiency has a maximum at approximately an oil mass fraction of 0.1 ( $x_o = 0.1$ ). The improvement of the isentropic efficiency is more remarkable at high outdoor temperature.
- The volumetric efficiency also increases with the oil mass fraction (until reaching a stable value at approximately  $x_o = 0.1$ ) thanks to a higher refrigerant mass flow rate caused by the sealing properties of the oil.
- The discharge temperature is drastically decreased with oil injection. For this study, it was decreased by 35-40°C for an oil mass fraction of 0.25 compared to no oil injection.
- Compared with a baseline system (no oil injection and no regeneration), oil-flooded compression and regeneration show promising results since the COP improvement between the oil-flooded system and the baseline system was between 4% and 15%, depending on the operating conditions and oil mass fraction. Moreover, the heating capacity improvement increased in the range of about 1% to 19%.

Future research should focus on conducting additional tests in order to determine an optimal oil mass fraction as a function of outdoor temperature and superheat. Moreover, it could be useful to control the superheat at the inlet of the compressor instead of the outlet of the evaporator to allow the refrigerant to leave the evaporator as two-phase flow and to be superheated in the regenerator.

## NOMENCLATURE

$\varepsilon$	Efficiency	(-)
$h$	Enthalpy	(J/kg)
$\dot{m}$	Mass flow rate	(kg/s)
$N_{rot}$	Rotational speed	(1/s)
$\rho$	Density	(kg/m <sup>3</sup> )
$S$	Slip Ratio	(-)
$T$	Temperature	(°C)

v	Specific volume	(kg/m <sup>3</sup> )
V	Volume	(m <sup>3</sup> )
$\dot{W}$	Power	(W)
x	Mass fraction	(-)
COP	Coefficient of Performance	(-)
RH	Relative Humidity	(%)
TXV	thermostatic expansion valve	(-)

### Subscript

a	air
cd	condenser
cp	compressor
ev	evaporator
ex	exhaust
fan	fan
in	indoor
is	isentropic
m	mixture
out	outdoor
o	oil
oc	oil cooler
r	refrigerant
s	displacement
sat	saturation
su	supply
vol	volumetric

## REFERENCES

- 2009 IEA (International Energy Agency) Online Data Services. <http://data.iea.org/ieastore/statslisting.asp>.
- 2014 Northeast Energy Efficiency Partnerships. Northeast/mid-atlantic air-source heat pump market strategies report.
- Bell, I., 2011, Theoretical and Experimental Analysis of Liquid Flooded Compression in Scroll Compressors, PhD thesis, Purdue University.
- Bell, I., Groll, A. and Braun, E., 2011, Performance of vapor compression systems with compressor oil flooding and regeneration, *International Journal of Refrigeration*, Vol. 34: 225-233.
- Bell, I., Groll, E., Braun, J., King, G., and Horton, W.T., 2012, Optimization of a scroll compressor for liquid flooding, *International Journal of Refrigeration*, Vol. 35, No. 7, p: 1901-1913.
- Hiwata, A., Iida, N., Futagami, Y., Sawai, K., and Ishii, N., 2002, Performance Investigation with Oil-injection to Compression Chambers on CO<sub>2</sub>-scroll Compressor, *Compressor Engineering Conference at Purdue University*, Paper #C18-4.
- Hugenroth, J., 2006, Liquid flooded Ericsson cycle cooler, PhD thesis, Purdue University.
- Hugenroth, J., Braun, J., Groll, E., and King, G., 2006, Oil Flooded Compression in Vapor Compression Heat Pump Systems, *IHR-IRHACE Conference*, p: 492-499.
- Li, H., Wang, D., Wang, H., and Chen, P., 1992, Research of oil-injected scroll compressor working process, *Compressor Engineering Conference at Purdue University*, p: 118b1-118b13.
- Ramaraj, S., Yang, B., Braun, J. E. Groll, E. A. and Horton, W. T., 2014, Experimental analysis of oil flooded R410A scroll compressor, *International Journal of Refrigeration, Elsevier*, 185-195.
- Yang, B., Blatchley, T., Bach C. K., Braun, J. E., Groll, E. and Horton W. T., 2014, Application of oil flooded compression with regeneration to a packaged heat pump system, *15th International Refrigeration and Air Conditioning Conference at Purdue*, p: 2631.1 – 2631.8

## ACKNOWLEDGEMENT

The authors would like to thank their colleagues at the Herrick Labs for their help with the design and testing of the system. In addition, the authors greatly appreciate the support of the research sponsors, Carrier Corporation, Indianapolis, IN and Emerson Climate Technologies, Sidney, OH.