

Spring 2014

# A Farm Management Information System With Task-Specific, Collaborative Mobile Apps And Cloud Storage Services

Jonathan Tyler Welte  
*Purdue University*

Follow this and additional works at: [https://docs.lib.purdue.edu/open\\_access\\_theses](https://docs.lib.purdue.edu/open_access_theses)

 Part of the [Bioresource and Agricultural Engineering Commons](#), and the [Databases and Information Systems Commons](#)

---

## Recommended Citation

Welte, Jonathan Tyler, "A Farm Management Information System With Task-Specific, Collaborative Mobile Apps And Cloud Storage Services" (2014). *Open Access Theses*. 281.  
[https://docs.lib.purdue.edu/open\\_access\\_theses/281](https://docs.lib.purdue.edu/open_access_theses/281)

This document has been made available through Purdue e-Pubs, a service of the Purdue University Libraries. Please contact [epubs@purdue.edu](mailto:epubs@purdue.edu) for additional information.

**PURDUE UNIVERSITY  
GRADUATE SCHOOL  
Thesis/Dissertation Acceptance**

This is to certify that the thesis/dissertation prepared

By Jonathan Tyler Welte

Entitled

A FARM MANAGEMENT INFORMATION SYSTEM USING TASK-SPECIFIC,  
COLLABORATIVE MOBILE APPS AND CLOUD STORAGE SERVICES

For the degree of Master of Science in Engineering

Is approved by the final examining committee:

Dennis Buckmaster

\_\_\_\_\_

Mark Tucker

\_\_\_\_\_

James Krogmeier

\_\_\_\_\_

Daniel Ess

\_\_\_\_\_

To the best of my knowledge and as understood by the student in the *Thesis/Dissertation Agreement, Publication Delay, and Certification/Disclaimer (Graduate School Form 32)*, this thesis/dissertation adheres to the provisions of Purdue University's "Policy on Integrity in Research" and the use of copyrighted material.

Dennis Buckmaster

Approved by Major Professor(s): \_\_\_\_\_

Approved by: Bernard Engel

03/04/2014

Head of the Department Graduate Program

Date

A FARM MANAGEMENT INFORMATION SYSTEM WITH TASK-SPECIFIC, COLLABORATIVE  
MOBILE APPS AND CLOUD STORAGE SERVICES

A Thesis

Submitted to the Faculty

of

Purdue University

by

Jonathan Tyler Welte

In Partial Fulfillment of the

Requirements for the Degree

of

Master of Science in Engineering

May 2014

Purdue University

West Lafayette, Indiana

To my grandfather, Clarence Welte, in appreciation for his guidance and wisdom

## ACKNOWLEDGEMENTS

Funding for this project was provided by the USDA National Institute of Food and Agriculture under grant 2012-67021-19404.

A huge thank you goes to my advisor, Dr. Dennis Buckmaster, and the members of my advisory committee, Drs. Daniel Ess, Jim Krogmeier, and Mark Tucker, for their guidance and valuable knowledge contribution.

Special acknowledgement is due to Aaron Ault for his expertise and guiding vision.

The author would like to like to thank his colleagues in the research group: Andrew Balmos, Shawn Ehlers, Elizabeth Hawkins, Matthew Koester, Alex Layton, and Sam Noel.

A special thanks to Cyrus Bowman and Steven Ellis for all their time and effort toward software development. This project would not have been as successful without their skill and commitment.

Recognition is due to the staff of the Agricultural and Biological Engineering department for their contributions that improve the quality of the experience.

A most heartfelt thanks to my patient and supportive girlfriend, Alyssa Slater, and my friends, Dalton Harbison, Chris Limiac, Andrew Loehr, Ethan Nilssen, and Daniel Skelton for making this an enjoyable experience.

## TABLE OF CONTENTS

	Page
LIST OF TABLES .....	ix
LIST OF FIGURES .....	x
ABSTRACT .....	xvi
CHAPTER 1. INTRODUCTION .....	1
1.1 Background .....	1
1.2 Motivation for a Mobile Apps-Based Data Management Solution .....	3
1.3 Research Objectives .....	4
CHAPTER 2. STATE OF THE ART AND LITERATURE REVIEW .....	5
2.1 Related Works.....	5
2.2 Farm Management.....	6
2.3 Farm Management Information Systems .....	10
2.4 Existing Farm Data Management Solutions.....	11
2.4.1 Desktop Software.....	12
2.4.2 Agriculture Apps.....	17
2.5 Requirements of FMIS.....	20
2.6 Identification of Technologies Available for Implementation .....	23
2.6.1 Data Sources .....	23
2.6.1.1 Manual Data Entry.....	23
2.6.1.2 Machinery Data .....	24
2.6.1.3 Internet-Based: Weather, and Geospatial Data .....	26
2.6.2 Data Transfer.....	28

	Page
2.6.3	Data Storage..... 30
2.6.3.1	Cloud Storage Services ..... 31
2.6.3.2	Network Attached Storage ..... 33
2.6.4	Mobile Devices ..... 34
2.6.5	Mobile Operating Systems and Applications..... 34
2.6.6	Mobile Application Development and Distribution..... 36
2.7	System Acceptance ..... 39
2.7.1	User-Centered Design ..... 41
2.7.2	Usability Studies..... 44
2.7.3	Usability Study Procedures ..... 46
2.7.4	Usability Metrics ..... 48
CHAPTER 3.	USER-CENTERED FARM MANAGEMENT INFORMATION SYSTEM
DESIGN	..... 50
3.1	User Groups and Stories ..... 50
3.2	User Interface Mock-ups..... 52
3.3	App Design Criteria ..... 53
3.4	System Architecture..... 54
3.4.1	Mobile Operating System Platform ..... 55
3.4.2	Data Transfer..... 55
3.4.3	Data Storage..... 56
3.5	App Programming ..... 57
3.6	App Distribution ..... 57
CHAPTER 4.	IMPLEMENTATION OF DESIGNED SYSTEM..... 58
4.1	Functional Specifications ..... 58
4.1.1	User Groups..... 58
4.1.2	User Stories ..... 61
4.1.3	User Interface Mockups..... 61

	Page
4.2	System Architecture..... 66
4.2.1	Local Sharing Between Apps ..... 74
4.2.2	Sharing Between Devices: Cloud Storage and Authentication ..... 76
4.3	Cloud Storage Services..... 77
4.3.1	Trello ..... 77
4.4	OpenAgToolkit Apps ..... 79
4.4.1	Tillage App..... 85
4.4.2	Planting App ..... 88
4.4.3	Rock App..... 91
4.4.4	Field Notebook App ..... 94
4.4.5	Trello Sync App..... 97
4.5	OpenATK Apps Currently In Development ..... 98
4.6	Summary ..... 100
CHAPTER 5.	METHODS TO DETERMINE TECHNICAL VIABILITY AND INTERFACE
USABILITY	..... 103
5.1	Technical Viability ..... 103
5.2	Estimating Data Storage Needs ..... 104
5.3	Usability Study..... 106
5.4	Weekly Usability Check..... 107
5.5	Pre-release Testing Procedure ..... 108
5.5.1	Recruiting Potential Participants ..... 108
5.5.2	Location ..... 109
5.5.3	Personal Interview ..... 109
5.5.4	Ensuring Participant Confidentiality ..... 111
5.5.5	Study Assumptions..... 112
5.5.6	Study Limitations..... 112
5.6	List of OpenATK Apps Tested ..... 113



	Page
5.7	Heuristic Evaluation of Usability ..... 114
CHAPTER 6.	RESULTS OF TESTING AND USER FEEDBACK..... 116
6.1	Amount of Data Generated by a 404 ha (1,000 acre) Farm ..... 116
6.2	Summary of Study Participants..... 117
6.3	Results of the Study ..... 118
6.3.1	OpenATK Rock App ..... 120
6.3.2	OpenATK Tillage App..... 120
6.3.3	OpenATK Planting App..... 121
6.3.4	OpenATK Field Notebook App ..... 122
6.4	Summary ..... 123
CHAPTER 7.	CONCLUSIONS AND RECOMMENDATIONS ..... 125
7.1	Conclusions ..... 125
7.2	Recommendations ..... 126
7.2.1	Usability Improvements..... 126
7.2.2	Future Apps ..... 129
7.2.3	Future Versions ..... 130
7.2.4	Future Research Opportunities..... 130
REFERENCES	..... 132
APPENDICES	
Appendix A	Example Functional Specifications..... 141
Appendix B	IRB Approved Recruitment Email to Potential ASM Student Participants . ..... 151
Appendix C	IRB Approved Recruitment Email to Potential PAC Employee Participants ..... 152
Appendix D	IRB Approved Consent Form for ASM Student Participants..... 153
Appendix E	IRB Approved Consent Form for PAC Employee Participants..... 159
Appendix F	IRB Approval Letter ..... 165

Page

Appendix G IRB Approved Personal Interview Script ..... 166

Appendix H Other Research Contributions ..... 173

## LIST OF TABLES

Table	Page
Table 1: Results from the usability study. A green box with a checkmark indicates the participant was able to complete the task without any assistance regardless of the steps taken. A red box with an X indicates the participant was unable to complete the task without assistance. ....	119

## LIST OF FIGURES

Figure	Page
Figure 1: Internal and external conflicts and problems a farm manager is likely to encounter throughout the growing season (Sorensen, et al., 2010). .....	8
Figure 2: Farm data and decision interactions from the farm manager’s point of view with the circular gray dashed line representing the farm system boundary and the darker gray dashed oval representing the boundary for the production of crops (Sorensen, et al., 2010). .....	9
Figure 3: The distribution of Android OS versions is much more fragmented compared to the Apple iOS. The distribution was updated on February 4, 2014 (Google, 2014 d.). ...	36
Figure 4: A flow diagram showing how apps transition to the background in iOS (Apple, Inc., 2014 b.). .....	38
Figure 5: A web showing the attributes of system acceptance. Note how usability and utility are components of the attribute usefulness (Haapala, et al., 2006). .....	41
Figure 6: Graphical representation of problem identification comparing two approaches; a single round of testing with eight users and two rounds of testing with three users each round (Krug, 2006). .....	47
Figure 7: OpenATK user Fred is the representative farm owner. Image from (TN.gov, 2010) .....	59

Figure	Page
Figure 8: OpenATK user Mike is the representative farm manager. Image from (Perlman, 2008) .....	59
Figure 9: OpenATK user Hank is the representative farm operator. Image from (Steimel, 2011) .....	59
Figure 10: The OpenATK Planting App UI under development using the tools and libraries within the MyBalsamiq UI development environment. ....	62
Figure 11: The progression of the Open ATK Tillage App mockups. (a.) The first mockup (Fall 2012) is a very function-heavy, user-tracking UI with Apple iOS themes. (b.) The middle mockup (Fall 2012) retained the Apple iOS themes but instead focused on the field operation status of each field. (c.) The last mockup (Spring 2013) adopted Android OS themes and a simplified UI, but retained the focus on the mapped fields. ....	63
Figure 12: Tillage App UI mockup of the most common use scenario. (a.) User selects a field and (b.) changes the operation status.....	64
Figure 13: Tillage App UI mockup demonstrating how the common use scenario can be simplified by inferring certain contextual information about the situation. (a.) The user’s device is in Field 4 that was “Planned” so the UI prompts the user to see if the planned operation is done and with the tap of alert box (b.) the field status changes to “Done”.65	65
Figure 14: Tillage App UI mockups showing how to navigate to the list view and bring up the field operation menu. (a.) Map View (b.) List View (c.) List View with field operation menu. By selecting a field in the list the operation menu slides up for more information. ....	66

Figure	Page
Figure 15: View of the system architecture from the perspective of four different devices on the farm (Welte, et al., 2013 a.). .....	68
Figure 16: View of a possible system architecture with a distributed data model from the developer’s perspective. The lines represent connections from the devices to the individual databases through the use of APIs and an internet connection. ....	69
Figure 17: View of the system architecture demonstrating local database sharing from the perspective of the system developer (Welte, et al., 2013 b.). ....	70
Figure 18: (a.) Screen shot of the Rock App showing four rock marker icons and (b.) a screenshot of the Tillage App showing the same four rock marker icons shared from the Rock App’s local database.....	75
Figure 19: Trello board for the Tillage App with a list for Disc 2012, Chisel 2012, Settings – Worker List, and Settings – Field List. ....	78
Figure 20: A view of the back of the card “OW294 – 09/27/12 – Hank” showing the tillage information stored in the card description.....	79
Figure 21: UI components are reused throughout OpenATK apps, Planting App (left) and Spraying App (right), to give the user an immediate feeling of familiarity when using a new app.....	80
Figure 22: An example action bar used in the OpenATK Planting App mockups. The items on the action bar, from left to right, are the app icon, operation type drop-down list, add new field, move map to user’s location, switch to list view, and action overflow. ....	81

Figure	Page
Figure 23: An example mock up with the Google Maps interface that is consistent across all OpenATK recordkeeping apps for field operations.....	82
Figure 24: The field operation menu mock-up to assist the user with recording the “who”, “when” and “where” details for an operation. ....	83
Figure 25: An example mock-up of the region-based record for the OpenATK Planting App. The top section of the record is specialized for the specific operation. An operation specific note for planting is what type of seed was planted, which is a common note for many farms. ....	84
Figure 26: The final Tillage App mockup before code development began.....	85
Figure 27: Screenshot of the Tillage App UI (V1.3) in a typical use scenario. The 56 acre Smith 56 field is selected and the menu allows the operator to record the date the operation was completed, his/her name, and any comments about the operation.....	87
Figure 28: A screenshot of the Tillage App Trello board with a list for Fall Chisel 2012 and Spring Field Prep 2013 and two lists which store information for the app. The Operator List saves a card for each operator drop-down list and the Field List saves a card for every field in the app. ....	88
Figure 29: The Planting App mockup is shown with Field 4 selected. The operator can make records for the current planting operation and then mark the field as done. ....	90
Figure 30: Example Trello board containing planting records from Ault farm for 2013. These were all entered by the operator using an iPhone or iPad while in each field.....	91

Figure	Page
Figure 31: The Rock App mockup showing three rock marker icons on a Google Maps interface. The rock marker icon in the top left is selected and the menu allows the user to add a note, take a picture, or mark the rock as removed.....	92
Figure 32: Screenshot of the Rock App UI (V1.3) showing five rocks marked for removal and four rocks marked as picked up.....	93
Figure 33: Screenshot of the Rock App Trello board with an individual card for each rock; five on the “Rocks In Field” list and four on the “Rocks Picked Up” list.....	94
Figure 34: The Field Notebook App UI mockup with Field 4 selected. The field list shows every note associated with Field 4 in a scrollable list.....	95
Figure 35: The Field Notebook App UI (V1.0) shown with Field 4 selected. The Google Maps interface shows the three notes associated with Field 4. One note (red) showing areas of the field where corn leaf necrosis was found, one note (yellow) showing the path walked for crop scouting, and one note (green) showing locations in the field leaf tissue samples were taken.....	96
Figure 36: A screenshot of the Trello Sync App (V1.1) where the user can select which OpenATK Apps should be synced to Trello. The screenshot shows the Field Work, Rock, and Tillage Apps all syncing to Trello indicated by the checkmark to the left of the app icon.....	97
Figure 37: Early mockups of the OpenATK (a.) Anhydrous App and (b.) Spray App used to help farmers keep better records of field operations. Many UI components are reused for a consistent user experience and instant familiarity. ....	100



Figure	Page
Figure 38: A screenshot of the Tillage App showing the 13 fields used for this study...	105
Figure 39: (a.) The current rock marker icon shown with an improved move icon. (b.) The current field boundary marker shown with an improved move icon. ....	127
Figure 40: The action bar shown with the new “add field” icon (shown on the far left)	127
Figure 41: ISOBlue enclosure version 1 shown with component tray slid out.....	174
Figure 42: ISOBlue enclosure version 2 shown with dual level component tray slid out. .....	174
Figure 43: ISOBlue enclosure version 2 rear view to show the ISOBlue name .....	175
Figure 44: ISOBlue enclosure version 2 with a semitransparent shell to show the internal layout .....	175

## ABSTRACT

Welte, Jonathan T. M.S.E., Purdue University, May 2014. A Farm Management Information System with Task-Specific, Collaborative Mobile Apps and Cloud Storage Services. Major Professor: Dennis Buckmaster.

Modern production agriculture is beginning to advance beyond deterministic, scheduled operations between relatively few people to larger scale, information-driven efficiency in order to respond to the challenges of field variability and meet the needs of a growing population. Since no two farms are the same with respect to information and management structure, a specialized farm management information system (FMIS) which is tailored to the realities on the ground of individual farms is likely to be more effective than generalized FMIS available today.

This thesis presents the design of a FMIS using proven user-centered design principles. This approach resulted in the creation of the OpenAgToolkit (OpenATK), and a suite of task-specific, collaborative Android apps. The OpenATK system architecture enabled apps to share data between apps on a device with shared local databases, and across devices on the farm using Trello application programming interface (API). Five Android apps, Rock App, Tillage App, Trello Sync App, Field Notebook App, and Planting App, were developed in the proposed architecture. Other apps such as the Anhydrous App and Spraying App were discussed with respect to their role in the OpenATK FMIS. The

OpenATK approach proved to be technically viable with current, consumer-grade technologies including free cloud storage, Wi-Fi, and task-specific, collaborative Android apps running on tablet devices. The Tillage and Trello Sync Apps were used to generate artificial records for one year on a 404 ha (1,000 acre) farm to evaluate data storage needs. The total amount of data generated for the six field operations on the 13 fields was 260 kilobytes.

Four OpenATK Apps were evaluated individually by four evaluators using the personal interview procedure for interface usability. The heuristic evaluation method was an appropriate evaluation method for the goals of this project as it enabled the observer to easily identify two critical interface usability problems: the long-hold method to move rock marker icons on the map and the method to draw field boundaries. Solutions to improve the usability problems were proposed, and recommendations were given for future research.

## CHAPTER 1. INTRODUCTION

### 1.1 Background

Predictions illustrate that the rate of food production must double before 2050 to feed the exploding world population. However, the rate of new arable farmland cannot continue to increase as fast as the last century. Farmers need enabling technologies in order to meet food production needs because they will be forced to produce more with the same amount of land. They can only achieve this goal by adopting new practices and refining existing ones. Farmers will see a shift toward a more information-driven management style with more focus on real-time growing conditions, documentation of quality, and environmental impact (Sorensen, et al., 2010).

Precision agriculture technology has advertised adoption benefits over the last two decades including more informed decision-making, increased farm operation efficiency, better awareness of environmental impact, and enhanced recordkeeping (Bleicher, 2013). However, current technology solutions still have commonly cited issues concerning data handling and compatibility. A survey report by Fulton et al. (2013, pp. 2) quoted a grower, "I know the data I am saving is valuable, but on a rainy day I would rather be in the shop than sit in front of my computer and manage my data." Many farmers have saved various data for years, but without a clear incentive or objective

they do not devote significant time or effort to turn that data into useful information thus leaving the majority of available data underutilized (Griffin, et al., 2004; Pesonen, et al., 2008; Sorensen, et al., 2010; Fulton, et al., 2013). Diekmann and Batte (2010) point out that while reducing input costs was identified as the greatest motivator for adoption of precision farming technology, nearly 80% of the 1,163 Ohio farmer respondents also identified the ability to gather better information for decision making as a motivator to adopt. Fountas et al. (2005) surveyed farmers in the eastern corn belt of the United States and Denmark and found that the most important impediments to precision farming implementation were the time requirement, lack of technical knowledge, and cost. The technical knowledge and time may be the reason older generations of farmers struggle with successful precision agriculture technology adoption (Fulton, et al., 2013). Yet, Whipker and Akridge (2009) identified costs and hardware/software incompatibility as most important when examining technology issues that create a barrier to expansion/growth in precision agriculture. Perhaps these impediments are the reasons that most of the farmers who have adopted the precision agriculture technologies tend to represent the largest operations in terms of acres cultivated and revenues generated (Diekmann and Batte, 2010).

The underutilized nature of seemingly endless data related to crop production is captured by these quotes: "Early innovators have upwards of 15 years of yield data and soil maps, but not many are doing much with that information," says Jeff Farrar, vice president of sales for Outback Guidance (Potter, 2013). "The evolution of this data management movement will allow growers, ag retailers, crop consultants, machinery

manufacturers, and others in the ag community to learn more about crop production at an accelerated pace compared to the past and will be a critical contributor to meeting the future food demand for the growing world population” (Fulton, et al., 2013, pp. 1).

### 1.2 Motivation for a Mobile Apps-Based Data Management Solution

As modern agriculture works toward the goal of doubling food production by 2050, information-based approaches certainly should help maximize efficiency with limited resources (Sindir, 2006). Since no two farms are the same with respect to information communication and management structure, a specialized farm management information system (FMIS) which is tailored to the realities on the ground of individual farms is likely to be more effective than generalized FMIS available today. A refined and integrated FMIS which incorporates low-cost, widely available mobile computing technologies, internet-based cloud storage services, and user-centered interface design principles has the potential to provide such a solution. There are also significant opportunities for the products proposed herein to be accessible to smaller farmers who have not yet been in a position to take advantage of the benefits precision farming technology offers. In addition, as the amount of information to be managed grows, more data will need to be provided *autogenically*: that is, created with semantic meaning without the need for manual human input (Welte, et al., 2013 a.).

Consumer-grade mobile devices, especially smartphones, are commonplace and possess more computing power than was used in sending the first spaceships into orbit. It seems logical to capitalize on this technology and utilize this mobile computing power to solve agricultural challenges.

### 1.3 Research Objectives

The overall goal of this research was to design, build, and evaluate an open-source suite of specialized, collaborative mobile applications (apps), cloud-based storage, and existing cellular data networks for record keeping and data management in agriculture.

The specific objectives were to:

1. Design a farm management information system with a decentralized data model.
2. Develop a suite of task-specific, collaborative mobile apps in line with user-centered interface design principles concentrating on usability with data sharing through cloud-based storage.
3. Evaluate the technical viability and interface usability of the mobile apps approach through the creation and testing of a subset of the collaborative mobile apps.

## CHAPTER 2. STATE OF THE ART AND LITERATURE REVIEW

### 2.1 Related Works

A study of Swedish precision farmers confirmed the need for a user-centered farm information system in information- and technology-intensive farms (Norros, et al., 2009). Norros et al. (2009) utilized the Internet for the communication method with potential users. A scenario video describing the system's key functional features was available to anyone online with the evaluation questionnaire to provided feedback to the developers. Some for the main results from this survey uncovered user needs including tools to evaluate the effects of different cultivation practices, analysis of existing farm data, tools to evaluate the influence of a certain cultivation practice on the whole farming business, methods to improve farming, and others (Pesonen, et al., 2008). Following this, Pesonen et al. (2008), gave recommendations and guidelines for a novel, intelligent, integrated information and decision support framework for planting and control of mobile working units which they implemented in the InfoXT project. They defined farmers' attitudes towards their work and profession to formulate the core task-based system usability claims (Pesonen, et al., 2008). Their evaluation methods focused on the system performance rather than individual user interface (UI) components. The system evaluators were expected to have considerable experience



and insight into the domain area (Norros, et al., 2009). After system validation and extensive analysis, they concluded that information management systems in mobile plant production environments should be internet-based with an open interface, and that farm data saved in a central database should be accessible to the farmer through internet servers (Pesonen, et al., 2008).

The European Union funded FutureFarm project identified the information model for six field operations (tillage, seeding, fertilizing, spraying, irrigation, and harvesting), and selected the information model for fertilization for analysis. The project specified the data provided and the information required for decision-making and used this to derive the flow of information which, in turn, resolves the design of the system. The analysis of the information model focused on the farmer as the primary decision maker (Sorensen, et al., 2010).

## 2.2 Farm Management

The farm management personnel's role is becoming progressively more complex as pressure from trade globalization, sustainability, and complex information and communication technologies becomes more prevalent (Sindir, 2006; Sorensen, et al., 2010). An important task of farm management continues to be increasing the farm's production and profit and to do so by properly allocating resources and implementing appropriate operational strategies. With the domestic and global markets becoming more competitive, farm managers must push their operations to maximum efficiency. The United States Department of Agriculture (USDA) recognized that a typical model for farm management does not exist because not all farms are the same size and type

(Sindir, 2006). Instead, the agency acknowledged farm management has five basic functions to achieve the goals and objectives of the farming business:

1. Planning: creating daily/seasonal priorities and schedules, recognizing areas needing improvement and finding alternative solutions
2. Organizing: establishing standard operating procedures and a structure of activities to meet the farm's goals
3. Managing human resources: recruiting, hiring, training and evaluating workers
4. Directing: delegation of responsibilities, establishing good communication with workers
5. Controlling: monitoring expenses and income, maintaining records of operations, comparing rates of productivity, making changes to practices as necessary, and more (Sindir, 2006).

Figure 1 depicts internal and external conflicts a farm manager could encounter throughout a growing season. European researchers developed the engagement web from general elaborations and responses from farm managers and external partners involved in the study (Sorensen, et al., 2010).

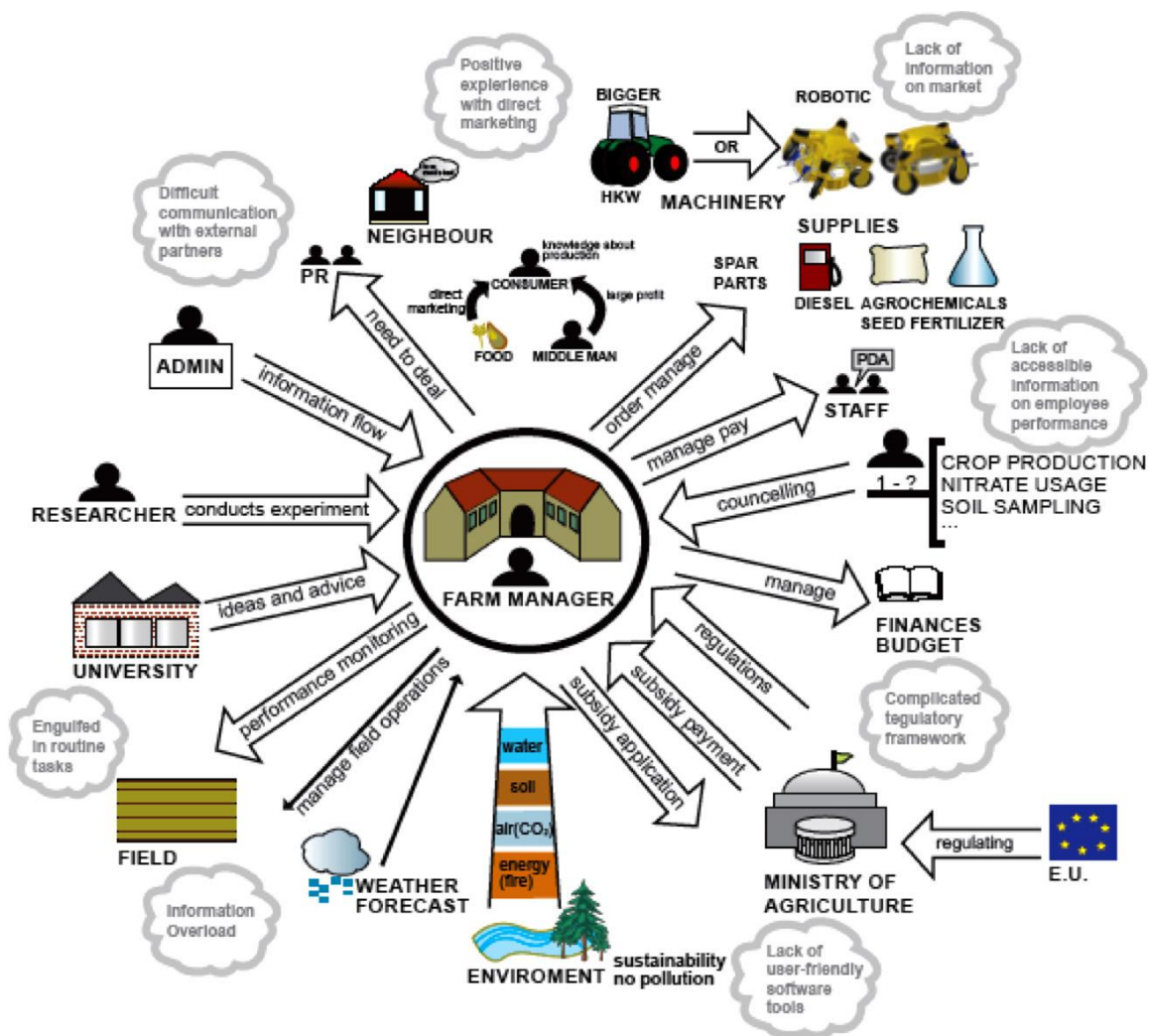

Figure 1: Internal and external conflicts and problems a farm manager is likely to encounter throughout the growing season (Sorensen, et al., 2010).

Sorensen et al. (2010) also developed an engagement web (Figure 2) from the farm manager's point of view with the circular gray dashed line representing the farm system boundary, and the darker gray dashed oval representing the system boundary for the production of crops. The visualization in Figure 2 was simplified from Figure 1 to show common and subsequent everyday management issues.

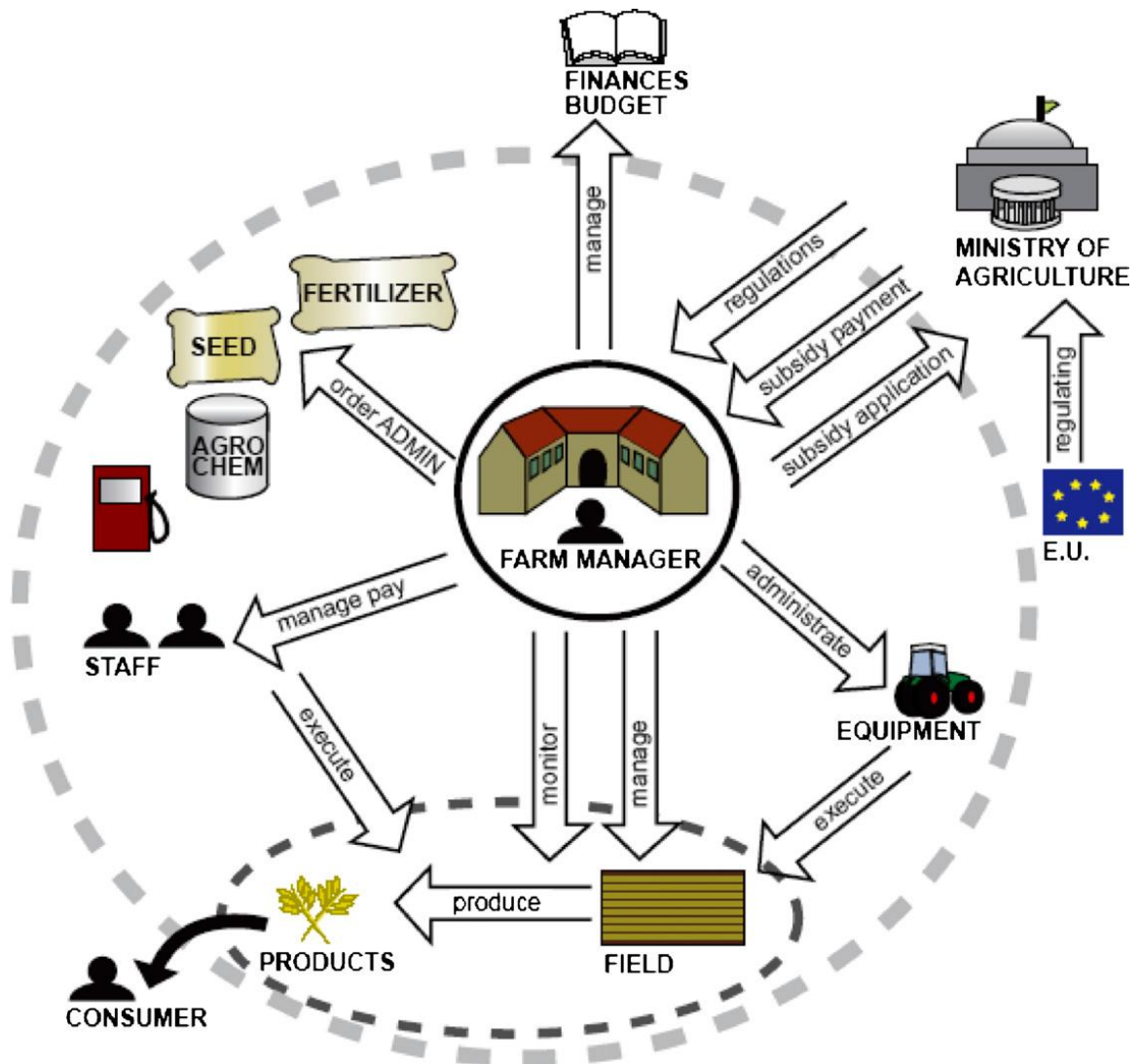

Figure 2: Farm data and decision interactions from the farm manager's point of view with the circular gray dashed line representing the farm system boundary and the darker gray dashed oval representing the boundary for the production of crops (Sorensen, et al., 2010).

While the farm manager is not likely to deal with all of these issues at once, many of these issues can be arranged into successive and parallel tasks. Many farm production processes and their sub-processes are diverse in nature and require the management to balance individual tasks within the seasonal farm plan (Pesonen, et al., 2008). For

example, spring tillage and planting are performed in succession on a field basis, but they are often performed in parallel across the farm. Spring planting requires a succession of tasks such as ordering seed and fertilizers, seed bed preparation, coordinating resources and more. Each task demands the attention of someone on the farm and can change priority based on weather, resources available, and the completion of previous tasks.

Farm management requires numerous decisions of various kinds, and most have many implementation options (Sindir, 2006). Typically the farmer deals with very complicated information flow paths since information comes from several sources (Pesonen, et al., 2008; Sorensen, et al., 2011).

### 2.3 Farm Management Information Systems

Operating an agriculture enterprise requires the management to make and implement numerous decisions across the operation throughout the season, and many times, away from the office. The management must process the necessary data in terms of recording, conditioning, and correlating (Sindir, 2006). The decision-makers also use information from a variety of resources, but the most valuable is often the source with information specific to the farm's operations, which often includes financial and operation records (Sindir, 2006). FMIS can be designed to deal with these issues and to support strategic and operational decisions (Nurkka, et al., 2007).

Nurkka et al. (2007) indicated that the management of information and decision-making are the core issues for successful farming. Nurkka et al. (2007) and Murakami et al. (2007) indicated data acquisition is not a hindrance for precision agriculture. While

Sorensen et al. (2010) point out that the use of computers and the internet has improved the task of handling and processing information, it remains a demanding task for the farm managers. They emphasize that there is potential of integrating various data sources when suitable information systems are developed and these should improve management practices. A variety of FMIS have been available to farmers, but unfortunately, the adoption of these systems has been relatively slow compared to other popular consumer-grade information and communication technologies.

#### 2.4 Existing Farm Data Management Solutions

Several reasons have been cited for slower than expected adaption rates of information technology, but the most common one is a poor understanding of both the system concept and the benefits to the farmer (Nurkka, et al., 2007). However, Haapala et al. (2006) believe the benefits are generally understood, and instead cite usability as the most likely cause for slower than expected acceptance.

While FMIS began as software tools running on desktop computers in farm offices, they are becoming more popular on smartphones and tablets. In many domains, the advances in mobile technology have started to erase the line between office and mobile software. This may be especially useful in agriculture where so much time is spent away from the office.

"Mobile technologies are enabling the precision ag consumer to become the most important asset once again," says Mike Santostefano, Director of Marketing and Business Development for AgIntegrated. "These consumers, including Precision Ag Specialists, Salespeople, Agronomists, Consultants, Operators, and Growers, are the

people responsible for adopting and embracing precision agriculture. As seen in other industries, these connected consumers will ultimately drive the need for lower cost, easier to use, integrated systems that make their day more efficient” (CropLife, 2012). The same CropLife article from March 2012 cites a shift in agriculture where various industry parties are showing a willingness to collaborate and integrate with each other through the use of application programming interfaces (APIs) to meet customer demands (CropLife, 2012).

#### 2.4.1 Desktop Software

The following section identifies several desktop software solutions to agricultural management problems.

**Ag Integrated – Onsite:** Onsite is a cloud-based, file management and communication solution with both a mobile and desktop application. This system is intended to complement and improve efficiency of the customer’s existing precision agriculture software systems (AgIntegrated, 2012).

**Ag Leader – SMS Software:** The SMS software is available in three different packages: Basic, Advanced, and Mobile. SMS Basic is designed to help the farmer make better decisions by keeping records of all farm data. SMS Advanced is targeted towards the larger farms and consultants. It includes all the features of the Basic package with additional features to help manage the added acreage (Ag Leader, 2013).

**AgriSight, Inc. – FarmLogs:** The FarmLogs software is a web-based FMIS which helps farmers track rainfall on their fields, monitor the local markets, and manage the farm activities. The interface easily lets a farmer add his/her fields to the farm field list to

begin recording cropping rotations, rainfall and more. The interface provides three different views. The dashboard is for finding a quick overview of recent activity, weather, market information, and more. The map is for seeing an aerial view of the farm fields which are color coded for crop, and can be sorted in the list by group, crop, or status. The calendar is for seeing a chronological view of operations. There is functionality to view historical information for each field, keep track of crop production costs, monitor inventory, keep track of markets and product sold, and keep records of equipment maintenance. The software is available for no cost for up to 404 ha (1000 ac) and one user (AgriSight, Inc., 2014).

**AgRenaissance Software LLC – FieldX Office:** FieldX Office can record field data for planting, chemical applications, tillage, harvest, field plans, scouting and recommendations on a Windows PC. Data entry can be streamlined by utilizing customizable templates. The software serves as a central interface for field data management and reporting. The farm's data can be synchronized with all employees and is backed up to cloud storage, FieldX Vault, with the ability to work offline (AgRenaissance Software LLC, 2013 b.).

**AgWorks, LLC – AgOS:** The AgOS platform is a set of agronomy software tools for agriculture retail operations. The AgOS software is composed of tools that cover seven different aspects of ag retail including Mapping, Precision, Operations, Scouting, Crop Planning, Grower Access, and Compliance (AgWorks, LLC, 2013).

**Case IH – Advanced Farming Systems:** The desktop software enables a farmer to layer data maps from other proprietary systems on top of aerial photographs. The derived



charts, graphs and layered maps can be analyzed to confirm or test management practices (Case IH, 2007).

**John Deere – Apex:** The Apex software helps the farmer maintain historical records for field data and generate spatial maps for analysis (Deere & Co., 2013 a.).

**Monsanto – Integrated Farming Systems (IFS):** IFS helps farmers match the “right” seed to their fields with the goal of getting more from every acre. The platform integrates Monsanto’s knowledge of seed science, agronomy, data analysis and precision equipment to maximize the potential for the field conditions. The software’s goal is to determine the optimal seed hybrid to be planted a certain way for a given soil rather than just increasing the field average. The software takes field boundaries from which it generates a yield management zone map. Then, it selects the best hybrid for the field and creates a variable rate seeding prescription, or FieldScript. Then it can be transmitted to the cab to the planter controller. The IFS platform was released for trials in 2013 with an expected commercial launch in 2014 (Monsanto, 2013).

**New Holland – Precision Land Management (PLM):** The PLM Data Management Solution is a complete software package to help farmers manage all aspects of the farm with the goal of increasing productivity and reducing costs. The free PLM Viewer software can be used for basic record keeping and reading data such as coverage maps (New Holland, 2013 c.). The PLM Mapping software was designed for record keeping, mapping, and analysis. It enables users to view a variety of geospatial data layers, and make visual comparisons. It also has functionality to create variable rate prescriptions and generate guidance lines for equipment (New Holland, 2013 b.). PLM Books helps

manage accounting records such as profitably, inventory and more (New Holland, 2013 a.). PLM Water Control is specialized for surface and sub-surface water management. It helps farmers analyze field topographical data to identify optimal placement of tile and drains for water management projects (New Holland, 2013 d.).

**Pioneer – Pioneer Field360 Services:** This web-based subscription software brings together field and weather data with agronomic information. The software is aimed at helping farmers quickly make more informed decisions. The software will run on any desktop, laptop, or tablet with internet access, and is fully integrated with the Pioneer Field360 Notes app (Pioneer, 2013).

**Precision Planting – FieldView:** The FieldView website leverages the benefits of a desktop or laptop computer web browser for FieldView Plus users with the 20/20 SeedSense monitor and FieldView iPad app. It enables farms to view current and historic data by connecting farmers with their data in the field through the Precision Planting cloud storage service, precisioncloud (Precision Planting ,2013 b.).

**Raven – Slingshot:** The Slingshot platform offers software and hardware tools to simplify data management associated with precision agriculture. The Slingshot Field Hub is the core of the platform. An annual subscription enables users to access the cellular-based Slingshot RTK correction signals and provide high-speed internet into the equipment cab for web browsing, file transfer, remote support and more. The Slingshot Field Hub is a small electronics enclosure that can connect to the major cellular networks in the United States (Raven Industries, 2013 c.). Slingshot Online services enable a user with an internet connection to access their asset location, make changes

to work orders, view historic records of field work and yield data and more in near-real-time (Raven Industries, 2013 a.). The Slingshot API is a software-to-software interface that enables third-party software to communicate with the Slingshot platform (Raven Industries, 2013 b.).

**SST Software – Summit:** SST Summit Basic includes functionality to create field boundaries from high-resolution images, generate field management zones, keep spatial records, create soil sampling schemes, exchange data with collaborating parties through SyncNow and generate value farm reports (SST Software, 2013).

**Trimble – Connected Farm Dashboard:** The dashboard provides farmers a single location to view a plethora of information pertaining to their operation. This web-based software is available on desktop and mobile browsers and comes with default widgets to aid farmers in making necessary decisions in and away from the office (Trimble Navigation Limited, 2009 a.). Farm Works, a division of Trimble, also develops various other desktop software for mapping, accounting, drainage, and livestock management (Trimble Navigation Limited, 2009 b.).

**United Soils, Inc. – I.F.A.R.M.:** I.F.A.R.M. is a web-based software tool to manage farm data. All data are backed up on offsite servers with redundancy built in. Software features allow the user to query and generate reports from a single window. Reports can be emailed, queued, or printed instantly or scheduled for later. I.F.A.R.M. is developed with AgIntegrated, and is in its third year of availability (United Soils, Inc., 2013).

**ZedX, Inc. – AgFleet:** AgFleet is a web-based set of modular software developed by ZedX, Inc. for on-farm decision support (ZedX, Inc., 2014 a.). Their modular approach includes software solutions for a variety of data management issues including data management (Data Manager), soil sampling (Field Sampler), record-keeping (Record Keeper), crop scouting (Scouter), management zones (Zone Maker), irrigation management (Irrigation), management analysis (Evaluator), and fertilizer blending (Blend, and Blend PrePlanner) (ZedX, Inc., 2014 b.).

A survey of agriculture professionals conducted by Fulton et al. (2013) noted that complexity of software interfaces and lack of compatibility between programs were inhibiting wider adoption. While many of the currently available solutions claim to be the best at managing farm data, many are missing a key aspect of a truly valuable FMIS which help farmers manage the day-to-day operations and implement the overall farm plan.

#### 2.4.2 Agriculture Apps

The following section identifies some mobile software solutions to agricultural management problems. Several software solutions described below were discovered with the help of a January 2014 Farm Industry News article that pointed out some of the top agriculture apps of 2013 (Huting, 2014). The article noted the best apps for a variety of categories, but the ones below focus on farm management:

**Ag Leader – SMS Software:** SMS Mobile helps the farmer collect field information such as crop scouting, soil sampling, boundaries and more. It also works with SMS Basic and

Advanced by providing another information source for decision making (Ag Leader, 2013).

**AGCO Corp. – AgCommand:** The AgCommand app assists with fleet management by allowing remote access to equipment location and machine performance history (Huting, 2014).

**AgRenaissance Software LLC – FieldX Journal:** FieldX Journal for iPad enables users to record data with or without internet connectivity while they are in the field. FieldX Journal synchronizes with FieldX Office through FieldX Vault. FieldX Journal capabilities include recording field data with customizable templates, view field borders and view historical journal entries (AgRenaissance Software LLC, 2013 a.).

**AgriSight, Inc – FarmLogs:** The FarmLogs app (available for iOS and Android) is free for all three subscription levels. The app enables users to get rain alerts for their location, view the farm map, log field activities and keep track of grain inventory (AgriSight, Inc., 2014; Huting, 2014).

**John Deere – Mobile Farm Manager:** The Mobile Farm Manager app is part of the John Deere FarmSight platform and gives the farmers mobile access to the field data from Apex. It also has the functionality for field scouting within the app. The app is available for free on iPhone and iPad. A sample farm is set up for demonstration but farm data in Apex is required for actual use (Deere & Co., 2014 b.).

**John Deere – JDLink:** The JDLink app is part of the telematics solution in the John Deere FarmSight platform. The app allows farm managers to see real-time information about their equipment including machine location, performance, maintenance tracking,

remote display access and more. The app is available for free on iPhone, iPad, and Android; however, a paid subscription is required for use (Deere & Co., 2014 a.; Huting, 2014).

**Precision Planting – FieldView:** The FieldView app (available for free on iPad) supplements the Precision Planting 20/20 SeedSense monitor (required) by showing high resolution planter performance data. The data is stored on the iPad and can be shared with other users through the Precision Planting cloud storage service, precisioncloud. The FieldView app is part of the Monsanto IFS and the FieldScripts service which allows farmers to work with their advisors to determine the best seed and planting population (Precision Planting, 2013 a.; Huting, 2014).

**Pioneer – Pioneer Field360 Notes:** The Pioneer Field360 Notes app enables the communication of agronomic information between DuPont Pioneer agronomists, sales professionals and the growers on a field-by-field basis. The app provides mobile access to the most recent field observations by sharing notes between farm employees. The app has functionality to make a geo-referenced note with a picture on the mobile device while the user is away from the office. This app is available for iPad, iPhone, and Android devices (Pioneer, 2013; Huting, 2014).

**Stringybark Software Pyt Ltd – Farm Manager:** The Farm Manager app allows the users to keep records of crops, livestock, and machinery maintenance. The app is available for free on iPhone and iPad, but a paid subscription will allow the data to be backed up and shared (Huting, 2014; Stringybark Software Pyt. Ltd., 2014).

**Trimble – Connected Farm Fleet:** The Fleet app is similar to other telematics software that gives farmers remote access to their equipment's performance and location with the ability to show historical positions. The app is available for free on iPhone, iPad, and Android. A demonstration is available on the app but equipment with Trimble monitors/controllers is required for actual use (Trimble Navigation Limited, 2013).

**Trimble – Connected Farm Scout:** The Scout app helps farmers map field boundaries and take scouting notes with geo-referenced pictures. The app comes pre-populated with a long list of crops, weeds, insects, and more. The app is available for free on iPhone, iPad, and Android (Trimble Navigation Limited, 2013; Huting, 2014).

Current data management solutions often fail to provide a sufficient (UI) that allows the farmer to make informed decisions (Welte, et al., 2013 a.). Pesonen et al. (2008) also point out a missing link in the current systems that prevent integrated analysis of the acquired data to produce usable information and knowledge. Farmers seem frustrated with currently available systems which stems from a lack of focus on the user experience with regards to farm management. Also, because of the proprietary nature of much of the equipment, it is difficult for third parties to produce integrated farm management solutions (Welte, et al., 2013 b.).

## 2.5 Requirements of FMIS

Multiple studies and surveys have been conducted in attempts to better understand the needs of the growers. Sorensen et al. (2010) noted the importance of understanding how the farmer views current information management methods including what he/she

thinks is working well and what is not working well. It is of great importance for the FMIS developer to understand what the farmer needs to make his/her daily working life easier and what would help the farm run more effectively (Sorensen, et al., 2010).

The following FMIS requirements were found to be the most important by Murakami et al. (2007) and several of these also directly relate to adoption:

- A system for the specific needs of the farmers
- A simple UI
- Simple or automated methods for data processing
- A user controlled interface allowing access to processing and analysis functions
- Integration of expert knowledge and farmer preferences
- Improved integration of standardized computer systems
- Enhanced integration and interoperability
- Scalability
- Interchangeability between applications
- Low cost

Fulton et al. (2013) echoed many of these same requirements based on a survey of farmers from the Midwestern and Southern United States and agriculture professionals nationwide during the winter of 2012/2013. They also elaborated on some desires and requirements from growers:

- Automatic wireless data transfer between machines and with cloud storage so data is stored in a single location



- Resources to find local support and training
- Web-based FMIS so data can be accessed from an internet-connected device
- Quick-start guides to make sure the technology is being set up correctly
- Standardized data formats and compatibility between different machines and operating platforms

Murakami et al. (2007) recommended an open software platform as an appropriate solution rather than a single proprietary system because it is unlikely that any single complex and comprehensive solution could meet all the requirements listed above.

When considering the core tasks of farm recordkeeping software, Pesonen et al. (2008) identified the following steps when focusing on managing field operations:

- Creating the operation plan
- Delivering detailed task plan to the field
- Setting up mobile working units to execute the plan
- Managing, controlling and recording the operation
- Documenting the as-applied operation for recordkeeping

In recognizing the various information sources, Pesonen et al. (2008) stated that these various sources needed to be easily integrated and combined for different analyses.

Murakami et al. (2007) noted that a simple UI was an important requirement when designing an FMIS. More specifically, Haapala et al. (2006) concluded that the information presentation and consistency with UI components was critical. They recommended that only information necessary to carry out a task should be presented

to the user, and information needed to be presented in a logical order. They also recommended that icons needed to be designed such that they had a clear meaning with respect to the task at hand. They found that inconsistency and lack of clarity, as well as poor choice of icons and language were likely sources of usability problems (Haapala, et al., 2006).

## 2.6 Identification of Technologies Available for Implementation

Technologies are identified here which build on the idea that new services and technologies can be added to the system as they become available. Independently developed services from other interested parties, assuming they are built upon the same concepts and hosted externally, can complement an open-nature of system as envisioned in this research project.

### 2.6.1 Data Sources

Data specific to the farm is possibly the most valuable source of information to support decision-making (Sindir, 2006). Thus, the keys to the success of any FMIS are accurate and timely generation and access to this data. Fortunately, useful data already exists, albeit in many forms within typical agriculture production systems. Understanding this variety of sources is necessary to enable specialization of an FMIS within a farm (Welte, et al., 2013 a.).

#### 2.6.1.1 Manual Data Entry

The simplest method of data collection is manual input. This traditionally consists of handwritten notes made with pen and paper. Long, standardized forms can overwhelm

operators if particular attention is not paid to the user experience. Providing simple, specialized apps for a variety of data entry tasks is crucial to getting standardized, minable data into the cloud where it can be put to use. Most people will not use mobile devices for data entry if such a switch entails more work, higher learning curves, and longer entry times than their existing system. Therefore, each data collection task should be automated to the extent possible. By making data entry faster and simpler than pen and paper, data in the cloud will be both more complete and more correct than inaccessible stacks of paper notebooks. Examples of manual data entry include: recording field, operator, rate, and tank number as anhydrous ammonia is applied, recording chemical mix, field, and date that a pesticide was applied, and recording seed variety, fertilizer, and area during planting (Welte, et al., 2013 a.).

#### 2.6.1.2 Machinery Data

Almost all machines and implements involved in modern production agriculture have sensors that are critical to machine operations and automation and can also create useful data in real-time during operation (Steinberger, et al., 2009). Some examples include: vehicle location, seed population, chemical application rates, wheel slip, fuel usage, crop yield, crop moisture, PTO status, hydraulic remote actions, and many others. The proprietary, non-standard nature of these machine sensors has traditionally limited their usefulness due to an inability for outside systems to access them. As compliance with the international standard for controller area network (CAN) communications on

serial busses in agriculture and forestry (ISO 11783) communications standard progresses, this hurdle is reduced but not yet eliminated.

Inexpensive, wireless networks of sensors using Bluetooth for communication would enable smart phones to collect data that is not tied to a particular proprietary source. While Bluetooth is not the ideal communications platform for sensor networking, it is generally inexpensive and widely implemented in smart phones. Sensors with relatively low data rates, such as ID tags and contact sensors can be easily retrofitted on existing machines and implements to provide information to autogenic algorithms (Welte, et al., 2013 a.).

The following section identifies a few machinery data projects and devices.

#### **ISOBUS Controller Area Network (CAN) Data Connections**

**Purdue University – ISOBlue:** The project aims to create a completely open source, inexpensive means for getting data from any ISO11783-compliant tractor to a Bluetooth-equipped mobile device in real-time. The mobile device can then upload the data to the cloud over its existing cellular connection. Enabling farmers and researchers to access, analyze, and store their own data will vastly improve the ability of precision agriculture technologies to finally reach their long-awaited potential of using statistical data mining techniques to optimize many features of agricultural production from yield to environmental impact (ISOBlue, 2013).

**Crop Ventures, Inc. – CANPLUG:** The CANPLUG device was developed by Crop Ventures, Inc. to support new and existing agricultural data software. The device plugs into the equipment ISOBUS diagnostic connector and can forward sensor data to web and

mobile software. Similarly to ISOBlue, the CANPLUG runs on a Linux Operating System and utilizes Bluetooth connectivity to transfer data to smartphones and tablets (Crop Ventures, Inc., 2014).

### **Implement Identification Tags**

**John Deere – Implement Detection:** Implement Detection is part of the John Deere FarmSight solution, and works with any ISOBUS-compatible implement. When paired with a GreenStar 3 2630 Display and the John Deere Implement Detection Controller, it can help operators reduce errors by ensuring implements are set up exactly the same year after year. The system remembers the last setting used and helps the operator get to work faster (Deere & Co., 2013 b.).

#### 2.6.1.3 Internet-Based: Weather, and Geospatial Data

Many types of useful information for FMIS are already publicly available online.

However, accessing this data is sometimes quite difficult due to a lack of application programming interfaces (API), and a general lack of data format standards. FMIS which can utilize data which does not need to be manually collected will greatly facilitate adoption and increase its ability to provide useful analysis.

Some examples of potentially useful data available within the United States include:

- **Weather Data:** Provided by the National Weather Service Advanced Hydrologic Service (National Weather Service, 2013). Daily, monthly, and yearly precipitation amounts are available going as far back as 2005. The data are

derived from a combination of radar and rain gauge measurements. Other weather data of interest could include temperature and wind speed.

- Soil data: Available from the USDA NRCS Web Soil Survey (USDA Natural Resources Conservation Service, 2013). It consists of geo-located polygons representing the survey map units, and tabular data with soil attributes to which the polygons are referenced.
- Light Detection and Ranging (LiDAR) Elevations: This extremely precise, remote-sensed elevation data is available from the Open Topography project (OpenTopography, 2013). Most LiDAR data has a horizontal resolution of 1.5 meters or less, but only 28% of the United States excluding Alaska was covered as of 2011 (National Oceanic and Atmospheric Administration (NOAA) Coastal Services Center, 2012). Potential issues with this high resolution data include data conditioning and delivering specific data sets to mobile devices (Noel, 2014).
- Common Land Units (CLU): “A Common Land Unit (CLU) is the smallest unit of land that has a permanent, contiguous boundary, a common land cover and land management, a common owner and a common producer in agricultural land associated with USDA farm programs. CLU boundaries are delineated from relatively permanent features such as fence lines, roads, and/or waterways“. CLU borders are available to Farm Service Agency, Natural Resource Conservation Service, and Rural Development employees through the USDA Geospatial Data Gateway (USDA Farm Service Agency, 2013). CLU borders for the

majority of the United States are available from AgriData, Inc. through their Surety software with a paid subscription. “Due to Section 1619 of the 2008 Farm Bill the CLU borders in Surety and Surety Pro are dated May of 2008” (Chad, 2013).

- Cropland Data Layer (CDL): This remotely sensed georeferenced raster data depicts detailed information on crop and non-crop land use to explore land-cover and land-use change in the contiguous United States (Han, et al., 2014). This spatial data is available through the CropScape (USDA National Agricultural Statistics Services, 2014) web application for visualization and download.

### 2.6.2 Data Transfer

The advancements in wireless data transfer technologies should enable FMIS providers to move away from the obsolete method of transferring data cards. Wireless networks are great tools to help farmers automatically transfer data back and forth between machines, employees, and the office (Pesonen, et al., 2008; Fulton, et al., 2013). The following section identifies some data transfer technologies common with consumer-grade mobile devices.

#### **Bluetooth**

Bluetooth wireless standard is a technology for convenient and secure wireless data transfer over short distances, up to 100 meters, using radio transmission. The technology allows paired devices to share voice, data, music, photos, videos and more. It has been built into billions of mobile devices and an ever expanding list of other

products including cars, medical devices, computers, and many more (Bluetooth SIG, Inc., 2013).

The Bluetooth Special Interest Group (SIG) recently released the Bluetooth 4.0 specification, Bluetooth Low Energy (BLE), to simplify the Classic protocol and eliminate some Classic features. These changes enabled battery-powered mobile devices with BLE to achieve power savings necessary to extend the battery power (Balmos, et al., 2013).

### **Wi-Fi**

The Wi-Fi term is actually a certification for wireless local area network (WLAN) devices (Wi-Fi Alliance, 2014). The Wi-Fi Alliance (2014) specifically defines Wi-Fi as any “WLAN products that are based on the Institute of Electrical and Electronics Engineers’ (IEEE) 802.11 standards.”

Wi-Fi technology is another extremely popular wireless data transfer technology with consumers. It uses radio wave transmissions for medium range data transfer and is a very common networking solution for homes, businesses, schools, airports, cafes, and more. Nearly all consumer-grade mobile devices have a Wi-Fi modem built in from the device manufacturer.

### **Cellular Data Networks**

Cellular data networks allow mobile devices to connect to the internet when a Wi-Fi connection is not available. The range of cellular data network signals can reach beyond 8 km (five miles) from the cellular network tower in rural areas. In the United States, cellular data providers include AT&T, Verizon, Sprint, and others, and require each user purchase a data plan. The common cellular network technologies include GSM, CDMA,



and LTE. These technologies are widely available in the United States with varying connection reliability and transfer speed depending on the provider's coverage in the user's area (Miser, 2012). Many device manufacturers build products with cellular modems built in, and it has become a very popular technology in consumer-grade mobile devices.

The potential for network interruptions is a major risk for a FMIS. A network disruption is more likely to be caused by lack of network availability than by a network failure at the provider's end. This type of interruption is unlikely because the service is likely maintained by professionals. A user would be unable to access the internet-based services in the event of network disruption regardless of its cause. The risk can be mitigated by enabling the user to load critical data to the mobile device when a connection is available to avoid major issues (Pesonen, et al., 2008).

### 2.6.3 Data Storage

A useful FMIS should make data available wherever and whenever it is needed. This need for secure, always-on availability was traditionally out of reach for most farmers because they do not have the resources to maintain their own Information Technology (IT) department to handle server maintenance, upgrades, backups, and security. Solving these particular issues is precisely why consumer-grade, file-based cloud services such as Box, Dropbox, Google Drive, Trello, CloudOn, and others have become so popular in recent years. These services give farmers the ability to have their data anywhere for a fraction of the cost of handling data in-house. The standard method in precision agriculture of transferring data between data cards and flash storage is unique to the

agriculture industry – agriculture could learn from the progress made by other industries (Welte, et al., 2013 a.).

#### 2.6.3.1 Cloud Storage Services

In a traditional farm setting, there are various pieces of equipment operating in different locations, and keeping the farm management system updated with data for each piece of equipment is inconvenient for timely data management. Cloud storage has the capability to solve problems with limited on-site storage, remote monitoring locations, mobile data sources, and real-time data access (Snyder, 2013). Several agriculture-specific solutions are beginning to appear in the marketplace including FarmLogs, John Deere's FarmSight, Trimble's Connected Farm, and AGCO's AGCOMMAND. The following section identifies some cloud storage services on the consumer market.

**Dropbox:** Dropbox is a cloud storage service with a free tier starting at 2 GB. A user can earn up to 16 GB by referring new users, enabling camera uploads, and more. Files can be accessed on mobile devices using the Dropbox app, on a computer with Dropbox installed, or any web browser. Dropbox's file structure is nearly identical to that on a computer. Files of various types are stored in folders. Dropbox handles the synchronizing of files between devices and provides a simple method to share files with people you choose (Dropbox, 2013 b.). Dropbox recently released the Datastore API to provide third-party developers a simplified way store structured data like contacts, to-do lists, and more. It supports iOS, Android, JavaScript, and Python with future support

for HTTP. It also supports offline access and automatic conflict resolution (Dropbox, 2013 a.).

**Fall Creek Software – Trello:** Trello is a free cloud storage service specialized to organize collaborative lists. The novel organization structure is immediately understood by virtually anyone because it resembles a board covered in note cards. This organization method is an intuitive combination of free-form and structured lists. It represents a number of individual items or tasks on cards which are grouped vertically into lists. One or more lists are then placed onto boards. Cards can easily be prioritized by moving them up and down within a list, or be moved between lists on a board. User accounts can be attached to cards to show who is working on which task. When an individual card is selected in the Trello interface, the back of the card shows deeper information including card description, file attachments, checklists, labels, due date and activity thread. Trello can be accessed through any internet browser or via apps on mobile devices (Fall Creek Software, 2013).

**Google – Drive:** Google Drive is a cloud storage service with free storage up to 15 GB that is shared across all Google account services including Gmail, Drive, and Google+. There is a file size limit of 10 GB. Additional space can be purchased for \$4.99 per month for up to 100 GB (Google, 2014 j.). Drive has the functionality to create and share documents, such as text documents, spreadsheets, and presentation slides, within the browser. Documents created within Drive apps do not count against the storage limit. Google Drive has support to view over forty different file types within the browser but allows users to upload any files (Google, 2014 a.). Developers on a variety of platforms

can take advantage of Google Drive storage capabilities within their apps by using APIs provided by Google through the Drive SDK (Google, 2014 g.).

**Apple – iCloud:** iCloud is a cloud storage service with free storage up to 5 GB. Additional storage can be purchased depending on the level of upgrade needed. For \$20/year the storage is increased to 15 GB. The storage can be increased to 25 GB for \$40/year and 55 GB for \$100/year. This storage is shared across all of the user's apps on all his/her devices. This enables iCloud to automatically back up and sync the content across all the user's devices (Apple, Inc., 2014 d.). iCloud storage is a service available for iOS and Mac OS developers for their third-party apps (Apple, Inc., 2014 e.).

**Microsoft – SkyDrive:** SkyDrive is a cloud storage service with free storage up to 7 GB. Additional storage can be purchased an additional 50 GB for \$25/year, 100 GB for \$50/year or 200 GB for \$100/year. The SkyDrive app is available on Windows, Mac, iOS, and Android (Microsoft, 2014 a.). Developers of mobile and desktop Windows Store apps can backup app data to SkyDrive using a SkyDrive API (Microsoft, 2014 b.).

#### 2.6.3.2 Network Attached Storage

Data storage devices have been gaining popularity as their cost continues to decrease. It is possible to easily add network attached storage (NAS) to a home or business computer network which can be shared with any other devices on the network. Many of the options available now also allow devices to access the storage remotely through an internet connection and a web interface. However, this option for cloud data storage

relies on the network owner/users to maintain the device and provide necessary data security. One example of NAS is the My Cloud hard drive from Western Digital.

**Western Digital – My Cloud:** My Cloud is a NAS from Western Digital with personal cloud storage capabilities. It allows multiple users to organize their content into one place at their home or business. My Cloud is available in configurations with 2, 3 or 4 TB of storage. Storage capacity can be expanded by plugging a USB 3.0 hard drive into the USB 3.0 port on the back of My Cloud. Local and remote access is available on PC, Mac, iOS, and Android (Western Digital, 2014).

#### 2.6.4 Mobile Devices

Smartphones, tablets and their associated software have transformed how people communicate and go about daily business. Modern agriculture needs to capitalize on these capabilities to significantly improve the process of data collection and analysis. By integrating sensors already on agricultural equipment with wireless technologies, the full potential of using cloud-based data mining to drive sophisticated graphical analysis can be achieved at near zero marginal cost (Welte, et al., 2013 a.).

#### 2.6.5 Mobile Operating Systems and Applications

The mobile operating systems and application software (apps) available are undoubtedly some of the most user-friendly and functional graphical user interfaces (GUIs). The ability to customize the UI for each app greatly increases the simplicity of the app and better facilitates a tailored FMIS approach. This benefits the potential users of a new FMIS because, initially, most data will be collected through manual input with the UI and the UI will serve as the primary data presentation method.

The following section identifies the two most popular mobile operating systems in the United States, which together represent almost 95% of the mobile OS market (Fingas, 2013).

### **Apple iOS**

The Apple iOS is the operating system that runs on the popular iPhones, iPads, and iPod Touch devices. Due to Apple's strict control over devices running iOS, the user experience is very consistent from one device to another. iOS represents a considerable share in the mobile OS market, especially in the United States. Fingas (2013) reported that iOS represents 13.4% of the global mobile OS market. The OS has been updated regularly with major changes coming on an annual basis. As of December 1<sup>st</sup>, 2013, the most recent iOS, iOS 7, represented 74% of all iOS versions running on Apple mobile devices. This is considerably higher than the 22% of devices running iOS 6 which was released one year before iOS 7 (AppleInsider, 2013).

### **Google Android OS**

The Android OS is an open-source mobile OS. Unlike iOS that can only run on Apple devices, the Android OS can be customized and installed on mobile devices built by any device manufacturer. This is a potential problem for developers because the user experience for their apps will vary from one device to the next. The Android OS represents the largest share of the mobile OS market at 81% globally (Fingas, 2013), and devices running the Android OS are generally cheaper than similar Apple devices. However, the distribution of Android OS versions looks very different than that of Apple

iOS as shown in Figure 3. This is also a potential problem for developers due to the need to support older versions of the Android OS to serve a substantial market.

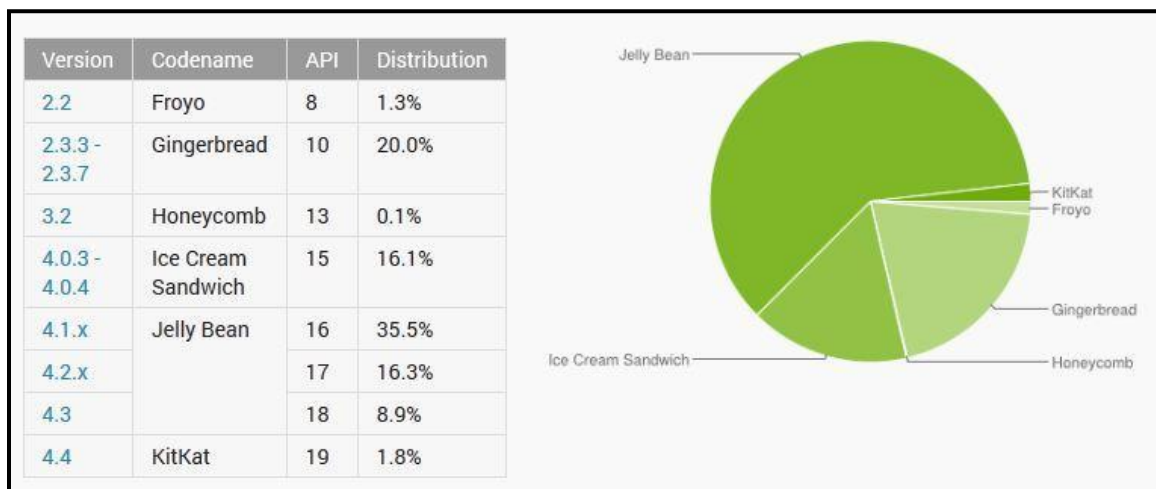

Figure 3: The distribution of Android OS versions is much more fragmented compared to the Apple iOS. The distribution was updated on February 4, 2014 (Google, 2014 d.).

## 2.6.6 Mobile Application Development and Distribution

### Apple iOS

The OS and other third-party apps are strictly regulated by Apple for quality control. For iOS users, among other things this means that only apps that Apple has approved and made available on the App Store can be downloaded. As a developer, this means there are strict development guidelines (Apple, Inc., 2014 a.).

One of the restrictions of concern for this project deals with how apps can store and share data on the device. Native app developers can save data locally using a SQLite database, and share data when their apps declare a unique URL scheme to allow collaboration with other apps (Apple, Inc., 2014 c.).

Another concern for this project is how apps can function in the background, which is when they are not the app currently running on the screen. To conserve the limited system resources on mobile devices only specific app functions are allowed to be executed in the background (Apple, Inc., 2014 b.):

- Playing audible content
- Recording audio content
- Keeping users informed of their location
- Support for Voice over Internet Protocol (VoIP)
- Downloading and processing new content regularly
- Receiving updates from external accessories

Apps that implement these functions must utilize the framework specified by Apple to avoid being suspended when they enter the background.

The process of how apps transition into the background is shown in Figure 4.



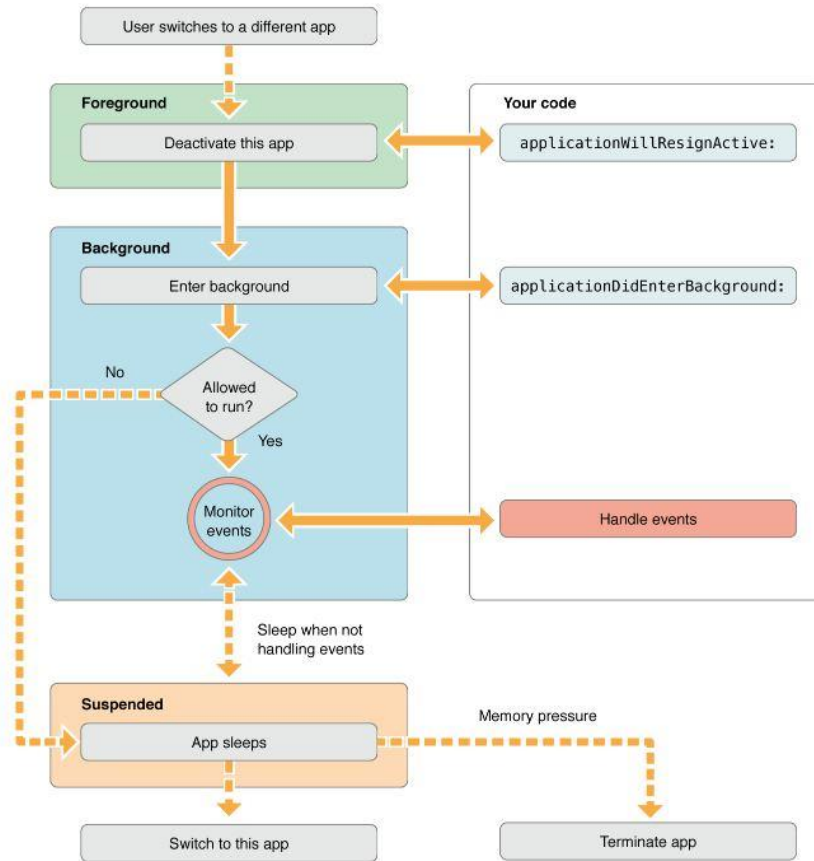

Figure 4: A flow diagram showing how apps transition to the background in iOS (Apple, Inc., 2014 b.).

### Google Android OS

Google's app approval is much more lenient than Apple's which can lead to an increase in users unintentionally installing malicious software. Android OS users can download and install apps and other content directly from the Google Play store (Google, 2014 l.). Additionally, users can download and install apps and other content from various sources such as websites, email attachments, and others.

Google also publishes development resources (Google, 2014 e.) to provide developers with reference material, sample code, training and more. There are multiple ways to save data locally for native apps, but the best method depends on the type of data being stored. Similar to iOS, the Android OS also uses the SQLite database structure to save data locally for native apps (Google, 2014 k.).

The Android OS provides methods to securely share data between apps on a device. One such method involves the implementation of content providers to manage the access of structured data. They are the standard interface that connects the data in one process with the code running in another process (Google, 2014 c.).

Similar to iOS, the Android OS is also able to run services when the app is not in the foreground. However, the restrictions on this activity are more lenient on the Android OS. Rather running a background service to sync data between the device and a web server, the Android OS uses a more power efficient framework called Sync Adapters (Google, 2014 m.). These methods make it very easy for a developer to transfer data between the device and a web server.

## 2.7 System Acceptance

User acceptance is often a limiting factor of adoption when new technology is introduced into the consumer market (Haapala, et al., 2006). A key determinant of successful acceptance by intended users is the extent to which the interface helps them accomplish specific tasks faster, simpler, and more efficiently (Nielsen, 2001). Farmers often make conservative decisions when considering adopting new technology. They

frequently prefer to proven techniques to reduce risk, and this is likely why new technology is slow to penetrate the agriculture market (Haapala, et al., 2006).

The term *usability* is a quality attribute that assesses how easy an interface is to use. The standard ISO 9241-11:1988 describes usability as “the extent to which a product can be used by specific users to achieve specific goals with effectiveness, efficiency, and satisfaction in a specific context of use” (Haapala, et al., 2006). Usability is a necessary quality in order to maintain user satisfaction. The users will become frustrated and eventually quit using software that is difficult to use. Developers can no longer expect users to read long manuals to use the software. Leaving becomes the easy choice for the frustrated users because there are many other options available.

Usability can be defined by these five quality components (Haapala, et al., 2006; Nielsen, 2012):

- **Learnability:** The ease of users accomplishing basic tasks the first time they encounter the interface
- **Efficiency:** The speed of accomplishing tasks correctly after the users have learned the design
- **Memorability:** When users return to the interface, the ease of reestablishing proficiency
- **Errors:** The summation of all simple and severe mistakes the users make, and the ability to recover from the errors
- **Satisfaction:** The users navigate the interface with a pleasant experience

Another important quality attribute is *utility*, which refers to the interface functionality. An interface with more utility provides a greater number of the features the users need. Usability and utility are equally important. Together the two attributes determine whether something is likely to be adopted by the user. These attributes are related to system acceptability as shown by Figure 5.

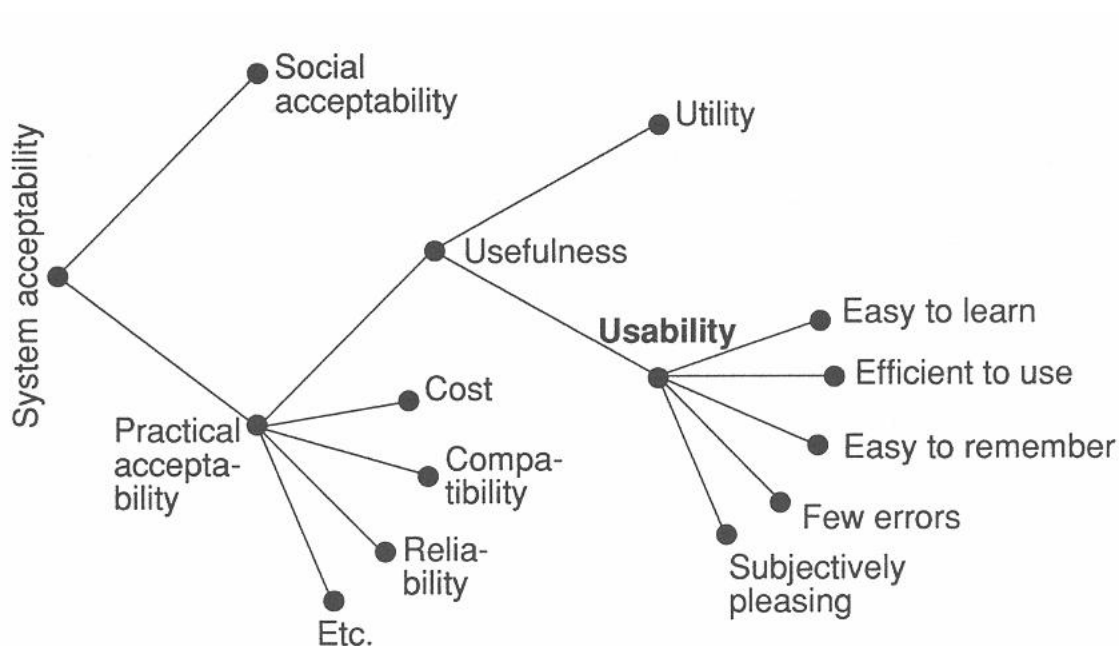

Figure 5: A web showing the attributes of system acceptance. Note how usability and utility are components of the attribute usefulness (Haapala, et al., 2006).

### 2.7.1 User-Centered Design

It is a waste of a good design if a very usable interface does not provide the right features to help the users accomplish what they want. It is equally frustrating if the software will do what you want to do, but the user cannot make enough sense of the interface to make it happen (Nielsen, 2012). Nurkka, et al. (2007) suggested that developers need an understanding of farmers' general attitude towards farming, their

conception of precision agriculture and how they make use of precision agriculture currently in their farming operation before they could begin to understand practical needs and demands of the farmer in the production of high quality crops. They emphasize this approach to system development with a user-centered focus can better predict the usability and user acceptance of the system.

The Human Computer Interaction (HCI) resources recommend involving the potential users in the development process of a novel system or product to ensure user acceptance and system usability. This is an important step to complete early in the development process when changes are easier (Pesonen, et al., 2008). There are many ways to accomplish this, but most approaches aim at direct contact between users and developers to help the developers understand the users' capabilities, needs and demands. These details are documented into user requirements and product attributes (Nurkka, et al., 2007). In the unlikely event that the potential user was also the sole developer, documenting the users' requirements would be somewhat unnecessary. However, this is rarely the case, and normally the development team consists of several developers that need to have the same understanding of the users' requirements. Various procedures for developing usable software have become somewhat standard in recent years.

One such standard procedure is the writing of functional specifications. Functional specifications document how a program will function from the perspective of its users. This method of communicating design decisions facilitates the iterative nature of product design. Functional specifications describe product features and the users'

interactions without deep consideration of implementation. Functional specifications differ from technical specifications in that they describe how a product will work solely from the users' perspective. Technical specifications then consider the internal implementation of the program that is specified by the functional specifications (Heap, 2011).

An important section of the functional specifications describe imaginary, stereotypical users. User descriptions should include personal characteristics, motives, job roles, etc. User interface designers benefit from the ability to imagine real people using the product when determining the appropriateness of the solution (Spolsky, 2000).

Sorensen et al (2010) suggest a similar approach where they analyzed the relationships, connections, and influences between system shareholders. They also point out the importance of capturing more subjective characteristics such as points of view, prejudices, spirit and human nature. This leads to the creation of character summaries and visual representations of the shareholders.

User stories complement the user descriptions by describing the real-world situations where people use the software being designed. User stories can include details of a specific activity such as a job description, environmental considerations such as distractions or hazards, desired interface behavior, anticipated problems, psychological state of the user, etc. (Spolsky, 2000). A variety of stories should be constructed to cover as many specific conditions as possible. Explicit details about the activity provide a clearer picture for user interface (UI) designers when considering variations of interface design. Details should include a description of the farming task being

completed with attention to the user's surroundings which often impose limits on the user's attention to the interface. Examples of common farming distractions include operating equipment at night or in standing crops and monitoring other devices in the cab (Welte, et al., 2013 b.).

User interface mock-ups afford product designers the ability to iterate the interface designs more rapidly than more formal representations. UI design often starts with hand sketching the screen layouts to visualize the interface with a paper model.

Interface design tools such as Balsamiq Mockups (Balsamiq Mockups, 2013) often incorporate software to provide image libraries for designers to drag-and-drop onto a template device. This method of producing UI mock-ups allows designers to generate and reproduce interfaces quickly while maintaining proper and consistent size proportions. The interfaces are verified with the user stories by visualizing each user holding the device and walking through the screens to complete common farming tasks (Welte, et al., 2013 b.).

### 2.7.2 Usability Studies

Usability testing can reveal the differences between the way developers and users think. It can shed light on parts of the product that, given their continued exposure to the project, developers take for granted aren't obvious to everyone. The basic idea of usability testing is very simple and powerful. If you want to know if your software or kitchen appliance is easy enough to use, watch people try to use it and observe where they run into problems. Then fix those problems, and rerun the test.

Focus groups can be used to get a quick sample of users' opinions and feelings to see if the idea behind a product makes sense. They usually consist of a small group of people reacting to designs and ideas presented to them. The risk with small groups of people is that it often becomes the collective opinion where participants react to each other.

However, listening to focus groups is not usability testing (Krug, 2006). Listening to what people say they "would do" can be very different from what they would actually do if they were the users (Nielsen, 2012).

Practical usability testing doesn't prove or disprove if something works. It's very difficult to answer the question if process A is better than process B. However, testing should be used to answer implementation in specific situations, such as "Does *this* menu layout and *this* wording present the correct information to create a good experience for the expected users?" The answers to this and similar questions can be used to inform the developers' judgment (Krug, 2006).

Personal interviews are much better suited for determining a product's usability. In this style of testing, one representative user at a time is shown the prototype and asked to use the product (Haapala, et al., 2006; Nielsen, 2012). A usability test of a new or novel system should include testing with the individual components and testing with the system as a whole. Typical tasks include using individual components or the entire system to figure out what it is and how it works, and trying to use component to accomplish some representative tasks working towards the success of the overall system. Observing where users succeed, and where they struggle is very simple and provides useful information (Nielsen, 2012).



### 2.7.3 Usability Study Procedures

Carefully watching users as they, individually, try to figure out how to use the software is the best way to determine usability. It is an iterative process where users are exposed to the product and asked to use it. Observations made about the users can help guide the product improvement process. After changes have been made, the test is repeated to determine if the users were more or less successful at using the product to complete the intended task. Usability studies should be completed with both novice and experienced users (Nielsen, 2001). If a product requires specific domain knowledge, users with that background should be recruited for as many rounds of testing as possible. However, it is far more important to test early and often with any users than wait to recruit users with specific background knowledge. Results should be assessed with respect to a potential inadequate background (Krug, 2006).

Rather than run a lengthy, expensive study, it's more useful to run several simple, quick studies. This iterative approach allows the developer to fix the obvious problems each iteration, and get the improved interface in front of new users. If a pool of twenty users is available for testing, it is more efficient to test five users for four iterations. In a single test with all twenty users, many of them are likely to find the same errors, but miss many others. If the developer takes the results from first iteration and fixes those, the next round of users will likely find completely new problems (Nielsen, 2012). Figure 6 demonstrates this approach.

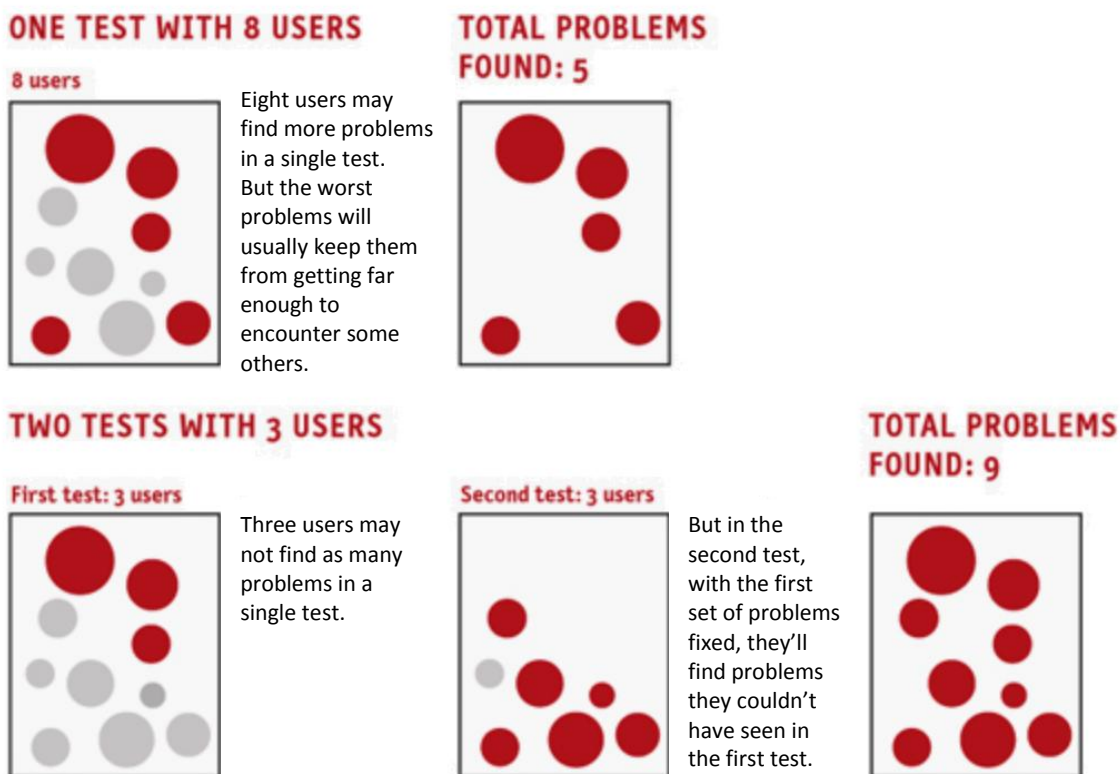

Figure 6: Graphical representation of problem identification comparing two approaches; a single round of testing with eight users and two rounds of testing with three users each round (Krug, 2006).

It can be very helpful to start new interface designs by testing older designs to figure out what works and what needs to be fixed. If this is the first version, a competitor's products can be tested to get information on an alternative solution. Time should be spent observing potential users in their normal environments to understand how the product will be used. When the design is ready for prototyping, very simple models should be tested with a plan to work up to a working prototype in iterations. Incremental improvements can be made between versions. It is much more difficult to fix the usability problems if the testing is put off until a fully implemented design is

completed. Fixing problems at the end could result in major changes across the design (Nielsen, 2012).

The location for a usability test can vary depending on various constraints. While it would be best to observe the user in his/her normal environment, it may be sufficient and necessary to conduct the test in a conference room or office. Distractions a user would be unlikely to encounter in the normal working environment should be removed (Nielsen, 2012).

#### 2.7.4 Usability Metrics

Usability is often measured relative to users' performance on a given set of tasks. The study includes success rate, time required to complete tasks, error rate, and others (Nielsen, 2001). These all contribute to the users' subjective satisfaction which is likely a culmination of the previous metrics; this satisfaction is the strongest indicator if the user will view the product positively (Krug, 2006).

Quantitative evaluation methods collect measurements which results in a numerical analysis to support a pending decision. While it may be very easy to specify the qualities to be measured, it can be very difficult to collect quantitative data. In order to draw statistical conclusions, the number of samples needs to be sufficiently large to reduce variability. Twenty or more users are recommended in order to get reasonably tight confidence intervals (Nielsen, 2001). A study of this magnitude would result in consumption of time, financial and human resources faster for each round of testing. Qualitative methods of usability testing often provide better insight for a fraction of the cost compared to quantitative methods. Heuristic evaluation methods have proven

effective for early detection of design deficiencies (Haapala, et al., 2006). Generally, five test users for each iteration is sufficient (Nielsen, 2001).

## CHAPTER 3. USER-CENTERED FARM MANAGEMENT INFORMATION SYSTEM DESIGN

For OpenATK, the anticipated user groups were identified, named, and described in detail with regard to characteristics, motives, and roles within the management structure. Representative situations involving these users were clearly described through user stories which provided a better mental picture when designing the UI. These users and example situations were developed from past personal experiences and conversations with farmers. Interfaces were then mocked up prior to developing code and tested against the user stories. An example functional specification for the OpenATK Tillage App is located in Appendix A.

### 3.1 User Groups and Stories

Often, defined job descriptions do not exist on a typical farm because individual workers fill a variety of roles. For this reason, users were separated into three groups and then classified as primary or secondary users. The user groups as they have been defined are upper management, middle management, and farm worker. The upper management user is typically in the farm owner position, whether the owner is a single person or a group of individuals. This user is responsible for decisions on the farm management level, such as seasonal planting rotations, purchasing, etc. The middle management user is typically an experienced employee who is responsible for day-to-day operational

decisions, such as allocation of human and equipment resources, training employees, coordinating maintenance schedules, etc. The farm worker user is considered any employee who performs general labor.

It is not uncommon for farm employees who hold management positions to also perform labor similar to that of a farm worker. It is important to group the users based on their primary role on the farm and understand that farm employees fulfill a variety of roles. Depending on the size of the farm operation, a single individual could be responsible for the yearly planning, the day-to-day decisions, and portions of the general labor.

Contractor workers such as custom applicators or harvesting crews are commonly employed by farms for temporary, specialized work and would be stakeholders in an FMIS. The farm and the contractors would both benefit from the contractors being granted limited access to the farm's FMIS. They would be able to retrieve work orders with the location of each field and marked hazards, and upon completion they could automatically send the as-applied map back to the farm office. However, the design of the proposed system focused on the three user groups mentioned above: farm owner, farm manager, and farm worker.

These general descriptions of users tend to be useful in getting a high-level picture, but they fail to allow the user interface designers to put themselves in the shoes of real people. To accomplish this, an imaginary person is created who would belong to each user group. This person is given a name that identifies them, and their name is used for all discussions and user stories. While this person does not fully represent every single

person that could ever belong to that user category, the danger of leaving out this step is that the software will be designed for “user categories” rather than actual “real-life” scenarios.

### 3.2 User Interface Mock-ups

User interface mock-ups afford product designers the ability to iterate the interface designs more rapidly than more formal representations. UI design often starts with hand sketching the screen layouts to visualize the interface with a paper model.

Interface design tools such as Balsamiq Mockups (Balsamiq Mockups, 2013) often incorporate software to provide image libraries for less artistic designers to more quickly drag-and-drop onto a template device. This method of producing UI mock-ups allows designers to generate and reproduce interfaces quickly while maintaining proper and consistent size proportions. The mocked-up interfaces can be verified against the user stories by visualizing each user holding the device and walking through the screens to complete common farming tasks (Welte, et al., 2013 b.).

The goal is to create very useful software, meaning that it is usable and has utility (Nielsen, 2012). The importance of the UI details should not be overlooked because the usability of the FMIS is critical. Often, the UI mock-up illustrated how complex the UI would be given all the functionality the developers desired. However, each user desires a well-designed, intuitive interface to help him/her accomplish the specific task at hand. A focus on this specific task can increase the usefulness of the limited screen size on mobile devices. The iterative nature of software design means the designers had to

reevaluate the balance between reducing functionality and simplifying the UI. These parallel design goals hopefully merged into a useful product.

### 3.3 App Design Criteria

**Embrace conventions:** Appropriate use of conventions makes it easier for first-time users to learn how to use an app without asking them to learn anything new.

Conventions provide a reassuring sense of familiarity that is comforting for the users (Krug, 2006).

**Minimal data entry:** Data should be shared across apps and devices to reduce the input of same data multiple times. Information entered manually by a user will ideally be reusable in other apps where appropriate, and exportable in standard formats for sharing and archival. Data acquired from existing internal and external sources should be utilized seamlessly.

**Minimal data requirements:** If necessary data are not available locally or externally the app should not fail, but rather operate with reduced functionality.

**Private synchronization:** To ensure that all apps and devices can share data a secure, internet-based data storage resource should be used. These cloud storage services should allow the users to own and control access to the data.

**Secure sharing:** The apps should provide secure and reasonably intuitive methods of sharing data not only with other farm employees, but also with agriculture consulting services, environmental agencies, and others.



**Off-line capabilities:** The apps should store at least the minimum pieces of information locally on the device to perform necessary tasks anticipating reduced internet availability in some environments.

### 3.4 System Architecture

Although there is a move to incorporate more data into agricultural decision-making, most information used for the kind of farm management decisions relating to fields, personnel, and machinery which occurs daily does not require access to large data sets. Data-intensive maps of yield, crop moisture, fuel usage, plant population, etc. are visually appealing and have the potential for improving some seasonal planning decisions, but these are not generally needed to make the sort of daily decisions which require mobility. For example, farmers need to know which fields remain to chisel plow this season as they contemplate where to work each day. All that is needed is a list of field names or a map of field boundaries that are marked “done” and “not done”, rather than point data. This sort of aggregated, high-level information is easily stored, updated, and accessed via standard consumer cloud storage (Welte, et al., 2013 a.).

The system architecture should be viewed from both the user and developer’s perspective. While the developer must be concerned with the data structure and management, these system details should be transparent to the user. A combination of existing technologies resembling current solutions may theoretically solve each issue on the farm individually, but this would likely result in a similar situation where information is stored on several on-site and off-site systems. The users need an integrated system with reduced complexity to solve their specific needs.

The technologies selected here are for the mobile operation system, data transfer, and data storage. An emphasis was placed on selecting system components that potential users already have experienced and may already possess to reduce the learning curve and investment cost. Another factor to consider when selecting system components was the stable operation of the system independent of the user's location or access to the internet.

#### 3.4.1 Mobile Operating System Platform

Several mobile device operating systems are common in the United States. The Android OS was selected for the initial proof of concept for this FMIS based on application distribution options and resources available to the research group. Due to the fragmented nature of the Android OS, a minimum Android OS version was selected during the development process. The selection was based primarily on the features implemented and less on the market share of each OS version.

In order to achieve market penetration, the designed system would need to support the maximum number of devices already owned by the potential users. These include older versions of the Android OS and especially the Apple iOS. However, this was not a concern for the project initially.

#### 3.4.2 Data Transfer

All new smartphones and some tablet devices have cellular capabilities and nearly every new device has Wi-Fi capabilities. Most device manufacturers deliver products with cellular and Wi-Fi network adapters and Bluetooth hardware built in. The popularity of

these data transfer technologies and their ease of use with consumer-grade devices are obvious benefits for any new FMIS.

The anticipated amount of data transferred in the proposed system is relatively low and for most situations the data transfer capabilities with cellular and Wi-Fi networks are sufficient. In the future, wireless data transfer rates should be tested with larger data files such as those associated with geographical information systems (GIS). The likely shortfall of cellular networks is the data limits imposed by cellular data network providers.

### 3.4.3 Data Storage

The FMIS needs to store data both locally on the mobile devices and in a cloud storage service. Data needs be stored on the mobile device in a SQLite database to support normal application operation and newly created data can be saved locally until a time when an internet connection is available to synchronize with the cloud storage service. While NAS and other personal cloud storage solutions exist on the market today, they were not considered for implementation with this project because they must be maintained by the user. This includes routine backups, protection from theft and fire, and other time consuming tasks that are not the general strengths of farmers.

The cloud storage services are assumed to be managed by professionals. Thus, data stored in cloud storage is considered to be safe and backed up.

There is no single data format that is recognized as a standard for communicating agricultural information. Several have been proposed such as agroXML (Association for

Technologies and Structures in Agriculture (KTBL), 2012), but the various proprietary data formats continue to dominate the market (Pesonen, et al., 2008).

The amount of data needed by any one mobile device user at one time is relatively small. Thus, existing mobile device storage and cloud storage should be sufficient. As some FMIS applications become more similar to GIS applications and data sets become larger and denser, local and cloud storage capacities should be reevaluated.

### 3.5 App Programming

The Eclipse software with the Android Developer Tools (ADT) plug-in was used for app development. The Android Software Development Kit (SDK) contains the API libraries and developer tools necessary to build, test, and debug Android apps. The ADT bundle is available for download from the Android SDK webpage (Google, 2014 f.). The bundle contains everything needed to get started programming for Android.

The code can be saved locally to the computer in the Eclipse workspace folder. However, several internet-based code repositories are available to help teams of developers collaborate and share code. Many have low cost or even free tier plans including GitHub (GitHub, Inc., 2014), Bitbutcket (Atlassian, 2014), and others.

### 3.6 App Distribution

A central web-based location is ideal for distribution of the collection of apps. This location serves as a place where users can easily find the appropriate set of apps to fit the needs of their operation. Users can download the application package files (APK) directly to their mobile devices for any apps they want. The APK files should be available on the Google Play store and the OpenATK website.

## CHAPTER 4. IMPLEMENTATION OF DESIGNED SYSTEM

### 4.1 Functional Specifications

The anticipated user groups were identified, named, and described in detail with regard to characteristics, motives, and roles within the management structure. Representative situations involving these users were clearly described through user stories which provided a better mental picture of the user for the developer when designing the UI. Interfaces were then mocked up prior to developing code and tested against the user stories. The functional specification written for the Tillage App is located in Appendix A.

#### 4.1.1 User Groups

In the case of the OpenATK FMIS, a representative set of users have been identified:

- Farm Owner Fred: (Figure 7) Generally older, more averse to technology, and very conservative. Fred has the final say in most planning and purchasing decisions.
- Manager Mike: (Figure 8) Generally younger, adept at new technologies, and is usually the first to suggest new changes to the operation. Any FMIS will likely be introduced to the farm through Mike, and therefore Mike will be responsible for making it run properly.
- Farm Hand Hank: (Figure 9) A typical employee at the farm. By virtue of his position as primary operator, Hank is the person who will interact with an FMIS the most. However, Hank has the least control over purchasing and implementation decisions for the farm.



Figure 7: OpenATK user Fred is the representative farm owner. Image from (TN.gov, 2010)



Figure 8: OpenATK user Mike is the representative farm manager. Image from (Perlman, 2008)



Figure 9: OpenATK user Hank is the representative farm operator. Image from (Steimel, 2011)

Each of these stakeholders interact with the FMIS in different ways due to variations in their perspectives of operational and management tasks. Users are classified as primary or secondary based on their interaction with the app. The primary users are directly interacting with the mobile device by recording data or using the information from the app to make decisions. An example of a primary user is an equipment operator recording field operation information with the Tillage App. The secondary users are indirectly using the app to complete an activity. An example of a secondary user is a farm manager using information entered by the farm worker to make a management decision. The app should be designed with the primary user in mind with consideration for interactions with the secondary user.

The farm owner named Fred will fill the upper management position and is responsible for year-to-year decisions on the farm level, such as cropping rotations and equipment purchases. He is an older person who has spent his entire life farming. His conservative approach to decision making often leads to hesitation towards change from the traditional, proven methods of farming. An experienced farmer named Michael, "Mike" to his friends, will fill the middle management position and is responsible for day-to-day decisions, such as the allocation of equipment and human resources. After graduating from college and working in a non-agriculture related industry, he has returned to the farm to work for his father. The farm worker named Hank will fill the position of general operator. His responsibilities include anything necessary to complete farming operations. The full text of the example functional specification is in Appendix A.

#### 4.1.2 User Stories

User stories were developed with consideration to each hypothetical user. The stories are very detailed descriptions of specific situations where one of the users is using the app to accomplish a particular goal. The details in the story give context to the situation for the developer who might lack domain knowledge, but they also put the developer in the same state of mind as the user. A story was constructed for every major function of the app. If a story could not be constructed for a particular feature, it was often the result of oversight in the brainstorming stage, and that feature was unlikely to be utilized. These extra features clutter and complicate the UI. The user stories document specific thoughts of the user and actions taken by the user to accomplish the goal.

One example of a user story from the OpenATK Tillage App puts Hank in the tractor getting ready to chisel a field. He opens the Tillage App, draws the new field boundary, inputs some basic information and continues the field work. The common use of the Tillage App for the equipment operators is marking a field operation “done” after it was previously marked as “planned” by management. It was important to make this expected use situation incredibly easy to accomplish quickly given that Hank’s main priority is completing the field work and not managing the farm. The full text is available in the example functional specifications in the appendix.

#### 4.1.3 User Interface Mockups

The following figures show example UI mockups for various OpenATK Apps. The interface mockups were first drafted by hand sketching the basic UI components. Next, the mockups advanced using the web-based software MyBalsamiq (Balsamiq Mockups,



2013) and its associated UI component libraries. Figure 10 shows the MyBalsamiq UI development environment with the Planting App UI being designed.

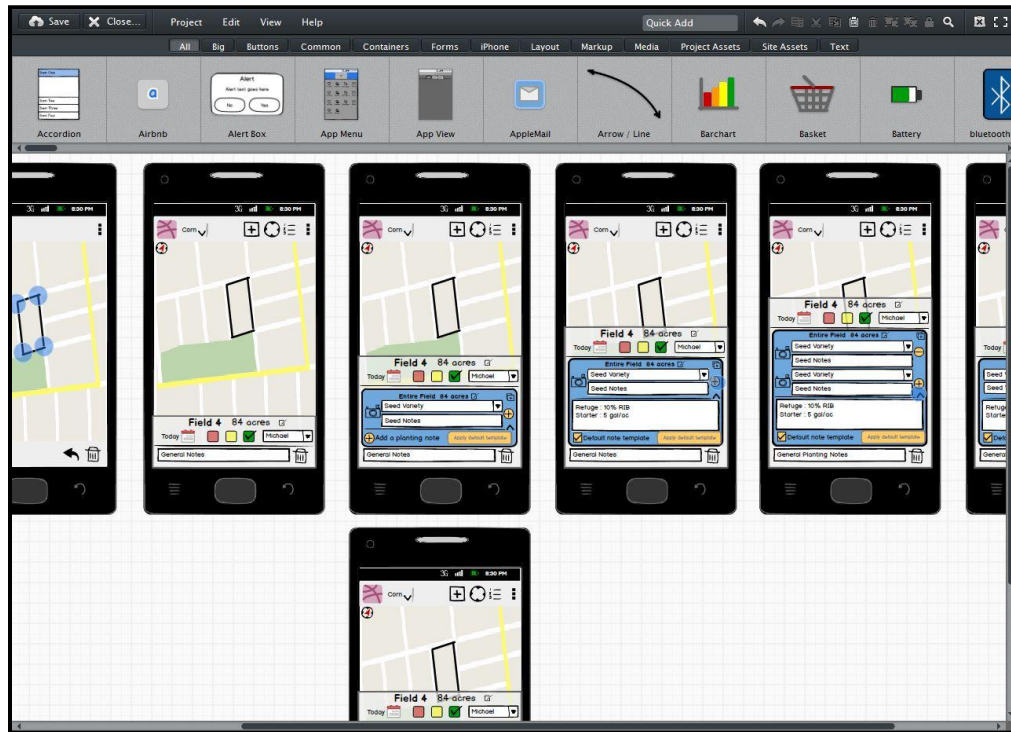

Figure 10: The OpenATK Planting App UI under development using the tools and libraries within the MyBalsamiq UI development environment.

Figure 11 shows the progression of the OpenATK Tillage App versions at three different stages throughout the iterative process of UI design. Each iteration focused in on presenting information to the user on which he/she could act on and reduce UI complexity. The final design (Figure 11 c.) had a simple UI to record field operation details with field boundaries on a Google Maps interface.



Figure 11: The progression of the Open ATK Tillage App mockups. (a.) The first mockup (Fall 2012) is a very function-heavy, user-tracking UI with Apple iOS themes. (b.) The middle mockup (Fall 2012) retained the Apple iOS themes but instead focused on the field operation status of each field. (c.) The last mockup (Spring 2013) adopted Android OS themes and a simplified UI, but retained the focus on the mapped fields.

It should be noted that the complexity of the initial designs led to a near complete redesign of the Tillage App UI. The designers attempted to pack as much functionality as possible into the software. Complex UI elements were removed when designers began to think about the software as the absolute most simplistic record keeping frontend UI for the backend cloud storage. This required the designers to reevaluate and rewrite original user stories. The functionality was reduced to more closely meet the user's expectations and needs to greatly simplify the UI. The goal of the design was to provide the software that growers needed and incorporate more functionality when it can be accomplished without compromising the UI simplicity.

Figure 12 walks through the most common use of the Tillage App where the equipment operator completes a tillage operation and changes the status of the field from “Planned” to “Done”. The entire process requires only two touch activities: 1) selecting the field and 2) selecting the correct status.



Figure 12: Tillage App UI mockup of the most common use scenario. (a.) User selects a field and (b.) changes the operation status.

However, the number of touch activities can be reduced to a single action if the app infers certain information about the situation. This functionality could be easily added by utilizing the Location APIs that help developers make location-aware applications (Google, 2014 i.). By analyzing the GPS location of the phone and observing its location in a field marked as “Planned”, the app can accurately infer that the equipment operator is likely completing the planned tillage operation in Field 4. Thus, the UI simply

asks the user if he or she has completed the operation, which can be confirmed by a touch and hold on the screen. Figure 13 demonstrates how the situation is handled if the equipment operator is in a field which is not marked as “Done.”

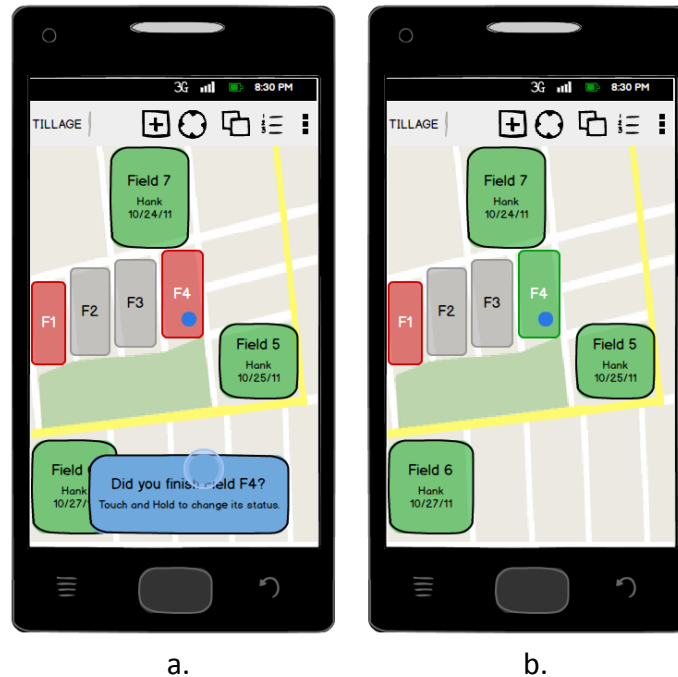

Figure 13: Tillage App UI mockup demonstrating how the common use scenario can be simplified by inferring certain contextual information about the situation. (a.) The user’s device is in Field 4 that was “Planned” so the UI prompts the user to see if the planned operation is done and with the tap of alert box (b.) the field status changes to “Done”.

While the map view provides a quick view to see the fields and their respective status, a list view provides a more efficient means to display summary information and more complete operation information. Figure 14 shows the proposed Tillage App list view where the user will find operational summaries and a list of the fields grouped by operation status in expandable lists.

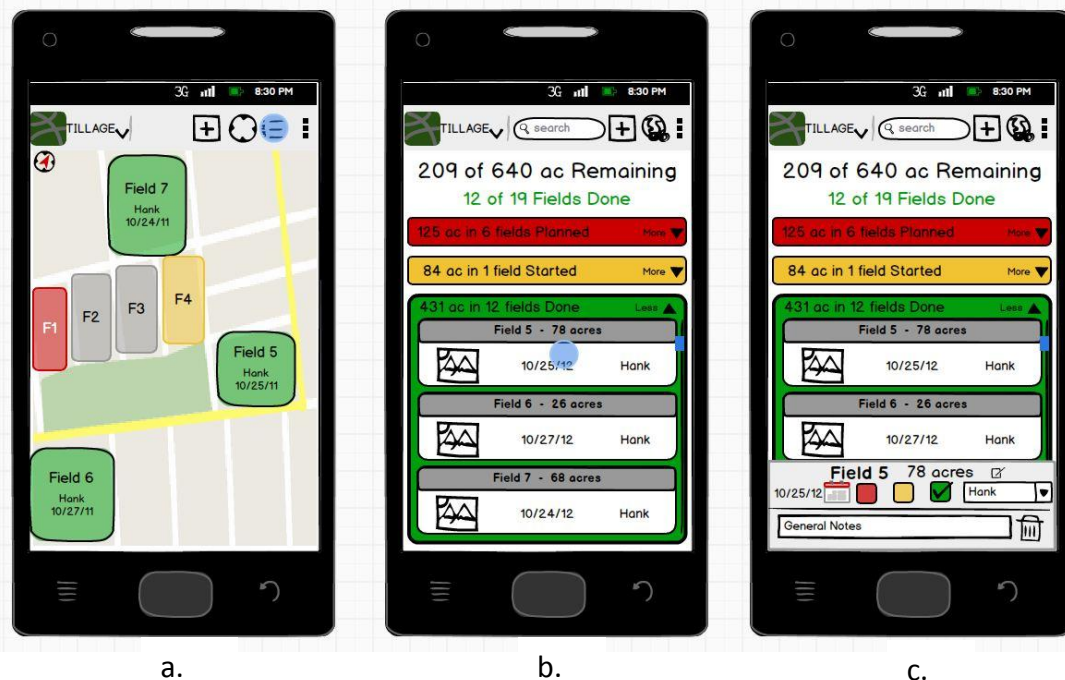

Figure 14: Tillage App UI mockups showing how to navigate to the list view and bring up the field operation menu. (a.) Map View (b.) List View (c.) List View with field operation menu. By selecting a field in the list the operation menu slides up for more information.

More mock-up examples are available in the functional specification in Appendix A.

#### 4.2 System Architecture

The result of our design process is a data management system of collaborative mobile apps with a distributed data model utilizing cloud-based storage services. Each app is intended to perform a specific task that solves a specific problem relating to an operation such as tillage, planting, or spraying. Where applicable, each task can be simplified in the future with automated data collection by inferring context from the location, interfacing the apps to peripheral devices, tapping into externally available data sources, and reading sensors through a standard ISOBUS. Sharing of data between apps and mobile devices on the farm is done through the cloud-based storage services

of Trello. This system should allow farmers to collect, protect, manage, and own their data without the need to pay expensive subscription fees or purchase costly devices (Welte, et al., 2013 b.).

The diagram in Figure 15 represents the example system architecture from the user's perspective using four different devices on the farm. Note how the user is only presented with the UI they need and the required information is retrieved from the FMIS. The app simply serves as a user-centered interface to the backend data storage. The arrows represent data transfer and do not represent any specific protocol. This is because the user does not need this knowledge or understanding to use the FMIS. The user only needs to know that the transfer of information occurs and is possible.

The arrows representing the transfer of rock information is one directional from the cloud storage to the Planting and Tillage Apps. Other apps, when selectively and appropriately synced, can share data, but ownership resides with the app that created the data. This is due to the fact that only the Rock App can create rock data. This approach allows the farms to put together a data management system to meet their particular needs. Thus, the system architecture would likely be slightly different among farms (Welte, et al., 2013 a.).

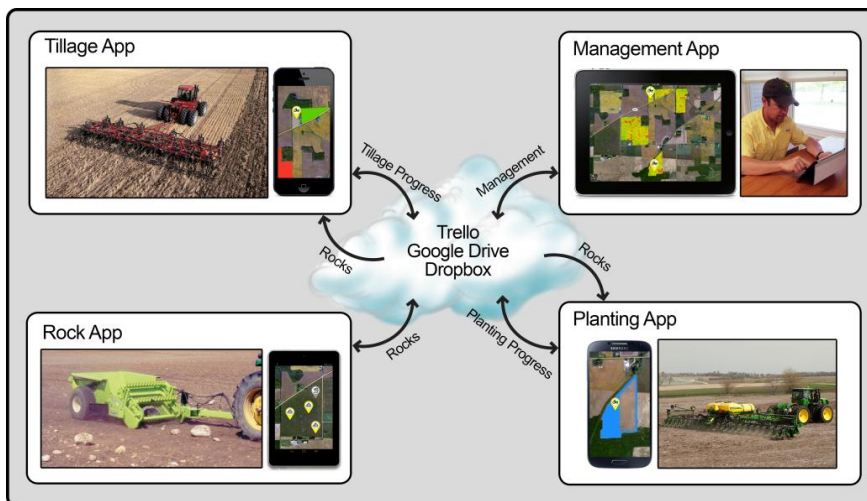

Figure 15: View of the system architecture from the perspective of four different devices on the farm (Welte, et al., 2013 a.).

The developer must be aware of the system details such as local libraries, sharing permissions, data format, and others. While a centralized database model was easier to visualize and has some advantages, a single database would need to contain all of the information a farm needs; this sort of database will be different for different farms. It was more efficient to utilize a database structure that already existed and is professionally maintained. The OpenATK apps communicate with the databases through the use of APIs and an internet connection. One benefit of the decentralized data model is that it allows farmers to use the cloud storage service(s) that they already use or one(s) that seem(s) most appropriate to them. Another benefit is that it allows one app to make a change to its database without affecting the rest of the system. The same things might not be true if the OpenATK approach used a centralized data model. The diagram in Figure 16 represents the system architecture with a distributed data model from the developer's perspective. The lines represent connections from the devices to the

individual databases through the use of APIs and an internet connection. Some lines are unidirectional indicating that the apps are only retrieving data from the database. Other lines are bidirectional indicating the apps are retrieving and saving data to these databases. Again, this approach allows the farms to find a tailored data management system to meet their particular needs, and the system architecture would likely be slightly different for each farm.

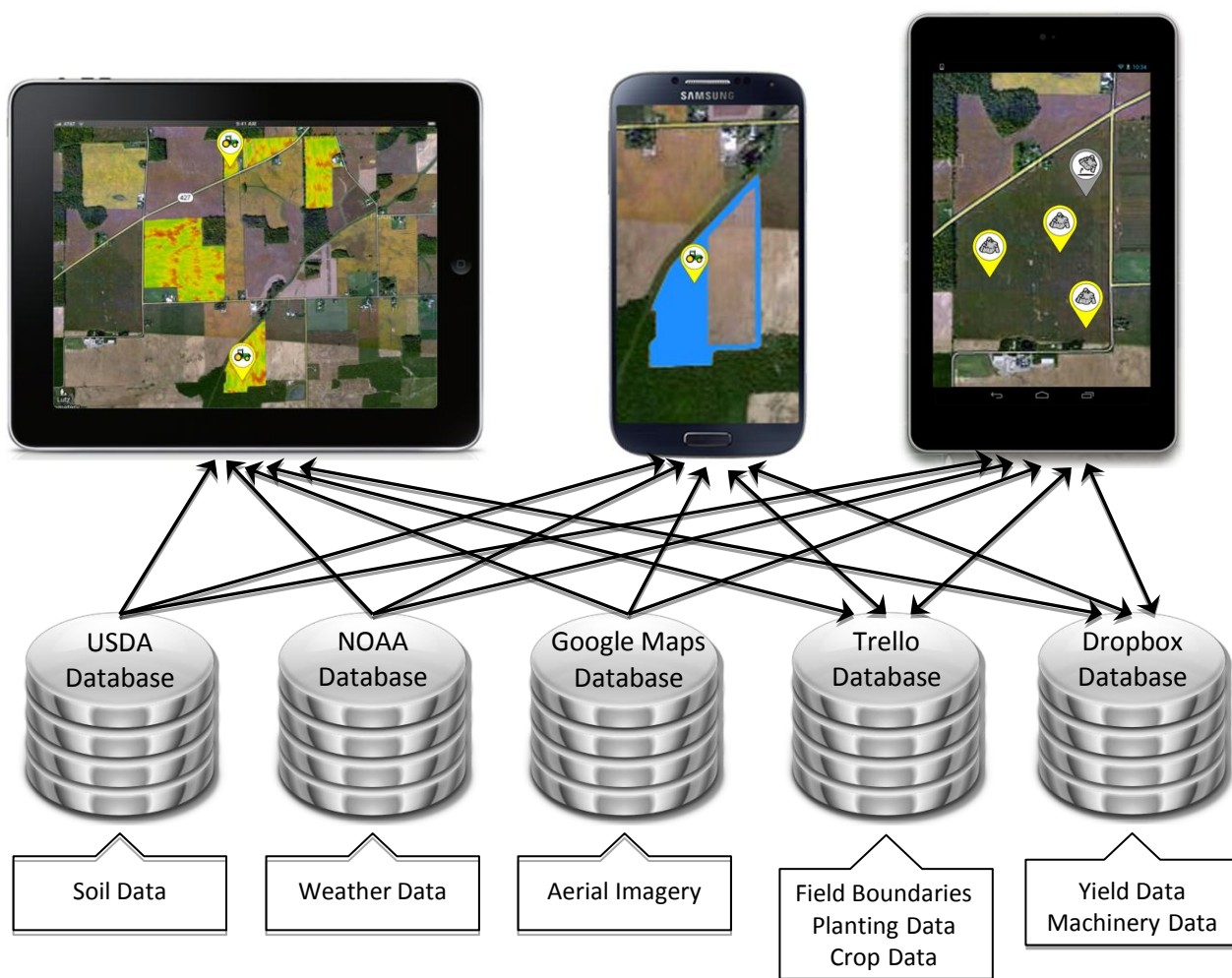

Figure 16: View of a possible system architecture with a distributed data model from the developer's perspective. The lines represent connections from the devices to the individual databases through the use of APIs and an internet connection.



The diagram in Figure 17 represents the system architecture demonstrating local database sharing from the developer's perspective.

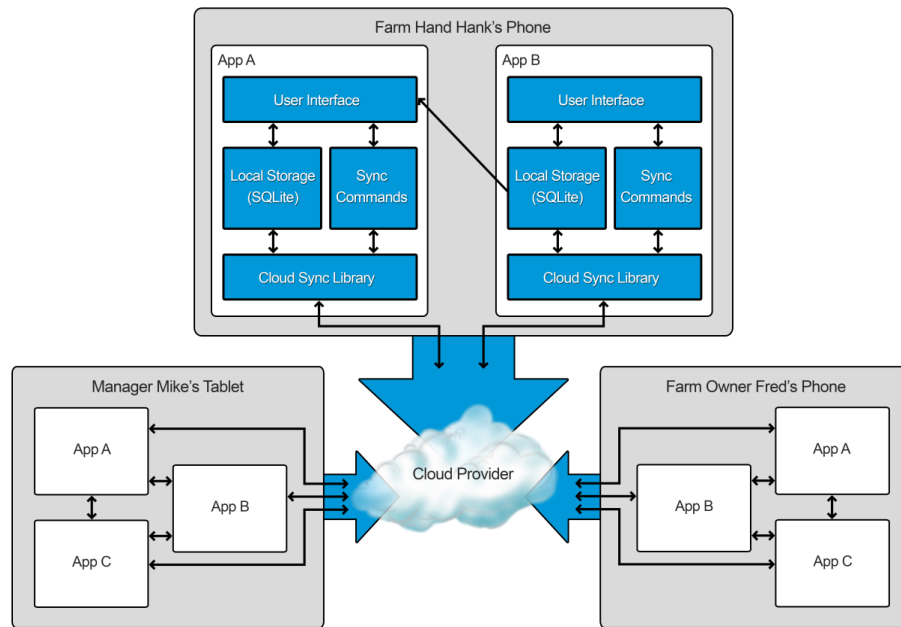

Figure 17: View of the system architecture demonstrating local database sharing from the perspective of the system developer (Welte, et al., 2013 b.).

Initially, each piece of data was to have only one parent app which is responsible for its Create, Read, Update, and Delete (CRUD) operations. Other apps on the same device could request data from its parent app if available, or use an app-specific means of providing data should the parent app not exist on the device. While this approach worked well for data such as rocks, it presented a potential problem when it came to data such as fields that are used in many apps. The following scenario explains how strict adherence to the original model of a single parent app could cause a usability problem.

- Manager Mike downloads, installs and begins to add the farm's fields to the OpenATK Tillage App.
  - The Tillage App requires a list of fields to work correctly, the Field Notebook App is not installed on the device to provide the list, so the Tillage App will maintain its own list of fields.
- Manager Mike instructs Farm Hand Hank to begin using the OpenATK Tillage App to keep track of spring tillage progress.
- They both install the OpenATK Trello Sync App to keep the progress synced between Mike and Hank.
  - This allows them to share the list of fields and keep Mike up to date on progress.
- Mike wants to try the OpenATK Planting App.
  - The Planting App also requires a list of fields to work correctly, the Field Notebook App is not installed on the device to provide the list, so the Planting App will maintain its own list of fields.
- Mike doesn't want to make a new list of fields because he already added them all to the Tillage App. So, he downloads the OpenATK Field Notebook App.
  - The Field Notebook App checks for other apps installed on Mike's device with a list of fields. It consolidates the list of fields into its local database, which can be synced to Trello also. It now becomes the parent app for fields, and thus, is now the sole provider of the field list. Now any app on

Mike's device will have to ask for the current list of fields from the Field Notebook App's local database.

- Mike's Tillage App no longer has a list of fields to sync to Trello and share with Hank. Hank's Tillage App and its Trello board cannot see the list of fields in Mike's Field Notebook App or its Trello board. That type of data sharing can only happen at the device level.
  - Hank's Tillage App now maintains a list of fields that is completely separate, and disconnected from the list Mike is using.
  - This is an obvious usability problem.
- Hank (and any other farm employee) is forced to install the Field Notebook App to keep the list of fields updated across all apps.

Additionally, Mike or Hank would have to go to the Field Notebook App when they wanted to add a new field regardless what operation app they were currently using. Instead, consider the following scenario where the single parent app rule is broken, and Hank, without the Field Notebook App, can add a new field in the Tillage App and have it available to both of them in their respective Planting Apps. Now, any app that needs a list of fields can maintain its own list, and only Mike needs the Field Notebook App.

- Hank and Mike have the Tillage, Planting and Trello Sync Apps installed on their devices. Additionally, Mike has the Field Notebook App.

- Hank is chisel plowing one day in a recently purchased field. While auto-steer has control of the tractor, he opens the Tillage App and adds the new field to the list.
- The Trello Sync App pushes the new field to the list on the Tillage App Trello board that Mike also uses. Mike's Trello Sync App pulls the new field and updates the field list in Mike's Tillage App.
- Mike's Field Notebook App regularly checks its list of fields against the list for other apps on his device, and it finds the new field in his Tillage App. His Field Notebook App grabs the new field, updates the field list and pushes the new list to the Tillage and Planting Apps on his device.
- The Trello Sync App pushes the updated field list to the list on the Field Notebook App and Planting App Trello Boards.
- Hank's Trello Sync App pulls the updated field list from the Planting App Trello Board and updates the Planting App's local field list.

This solves the problem with forcing Hank to download the Field Notebook App when Mike does in order to keep his list of fields up to date. Thus, the single parent app approach should be evaluated for appropriateness on a case-by-case basis.

To synchronize a particular app's data across devices, a general synchronization library transforms the local, app-specific data into the format best suited to the chosen type of cloud storage. For example, the Rock App synchronization process to Trello treats each

rock as a Trello card that resides in either a “Picked Up” or “Not Picked Up” list. The library synchronizes any activity on Trello to the local Rock App database, and vice-versa.

#### 4.2.1 Local Sharing Between Apps

In order to provide flexibility from a user’s perspective, relevant data from each app can be shared between apps on a device, and shared with other devices on the farm using cloud storage. Initially, each app shares its data locally with any app that requests it. On Android this is accomplished using content providers to SQLite databases. This allows each individual app to supply read or write access for its data to all other apps that request it which have been identified as valid OpenATK apps.

Figure 18 demonstrates this ability with (a.) a screen shot of the rock marker icons on the map in the Rock App, and (b.) a screen shot of the Tillage App showing the rock marker icons from the Rock App’s local database.

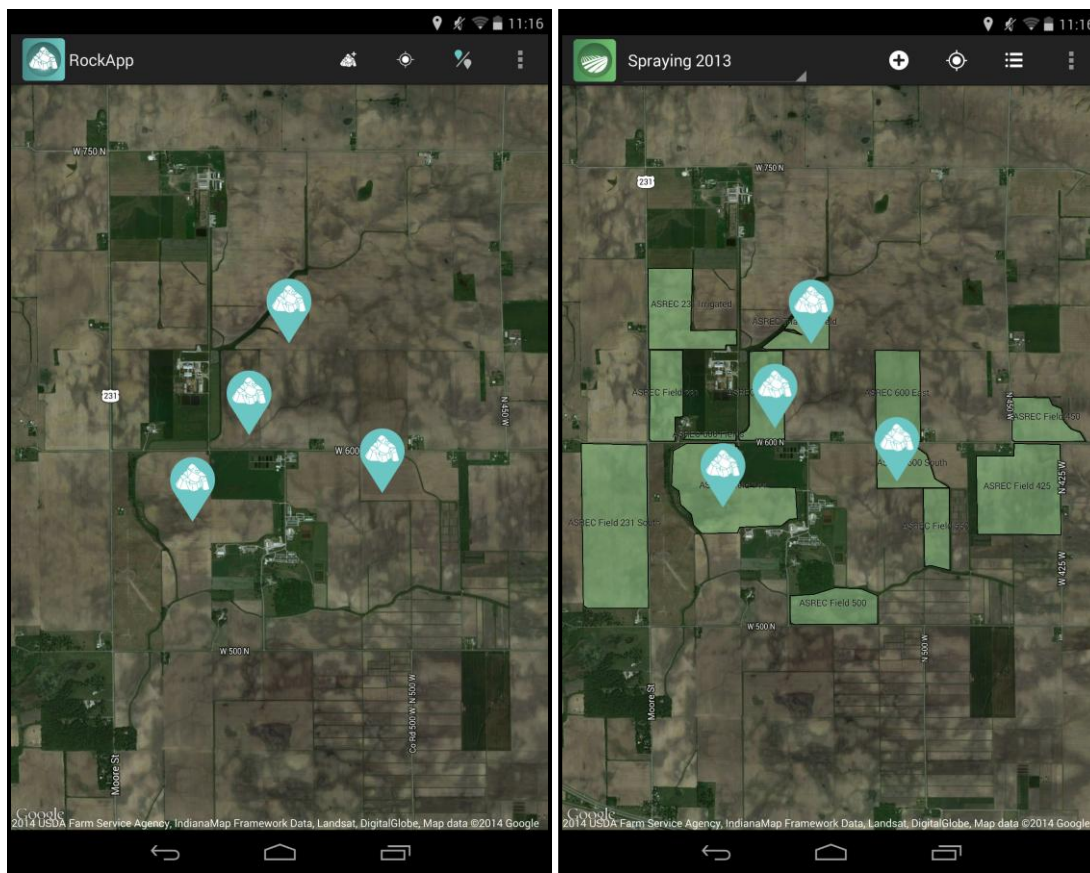

a.

b.

Figure 18: (a.) Screen shot of the Rock App showing four rock marker icons and (b.) a screenshot of the Tillage App showing the same four rock marker icons shared from the Rock App's local database.

Data can also be shared with other devices on the farm. Shared libraries can be written to provide data syncing capabilities to a variety of cloud storage services including Trello, Google Drive, Dropbox and others. Each app implements app-specific extensions to these shared libraries to allow cloud storage of important data. From a user's perspective, cloud syncing is controlled by a corresponding cloud storage app. Each cloud storage app allows the user to input their credentials to the service and control which apps sync to this service. Necessary cloud storage authentication information is

shared on Android through a content provider from the cloud storage app to any apps that use the corresponding shared library to sync data. This allows any app to sync to any cloud storage service and eliminates the necessity for a user to reenter authentication information into each individual app.

#### 4.2.2 Sharing Between Devices: Cloud Storage and Authentication

By using existing cloud storage services, the complex task of sharing and authentication can be offloaded from the small-scale developer or technology-savvy farmer. Cloud storage providers generally use protocols such as OAuth (OAuth, 2014) in order for apps to acquire tokens needed to access a data. In this way, apps can simply synchronize their data to the cloud storage service for whichever user is currently logged in, eliminating the need for a separate server which maintains logins, passwords, and sharing permissions.

Consider the case where Manager Mike is logged in to Google Drive on a particular device, and the Rock App is syncing its data to a file in a shared folder. If Farm Hand Hank now logs in to Google Drive on the device, and Hank has the same shared folder, the app will now sync data through Hank's account. Since data is shared within the same farm, switching users will not trigger a full-scale synchronization task because the data will look the same from every user's perspective. Only when one device switches between different farming operations will data need to be synchronized in full.

### 4.3 Cloud Storage Services

#### 4.3.1 Trello

Trello's biggest advantage is its ability to provide backend storage which makes sense to the common person (Ault, et al., 2013). The current design of the Open Ag Toolkit utilizes Trello as the backend cloud storage service for its mobile apps. The app design process aims to match the elements in the app with elements in Trello as one-to-one in order to help users intuitively understand how changes to their Trello board affect the app. Each app has its own board which shares its name.

For example, the OpenATK Tillage App uses a Trello board titled "OpenATK - Tillage".

There are corresponding lists for each type of tillage listed in the app: e.g. the "Chisel 2012" mode uses a Trello list titled "Chisel 2012". Adding a new list to Trello will cause a new tillage mode to be available in the app. Each Trello card represents one field for a particular tillage operation as "Planned", "Started," or "Done." Fields that do not have cards listed for a particular tillage mode have a default status of "Not Planned." In order to maintain the list of fields and field properties such as acreage and boundaries, a special list in Trello titled "Settings" can be used to store field information and other items specific to the app. Figure 19 shows an example Trello board for the Tillage App. Note how each card represents a single tillage operation with the front of the card showing the field name, operation date and operator name.



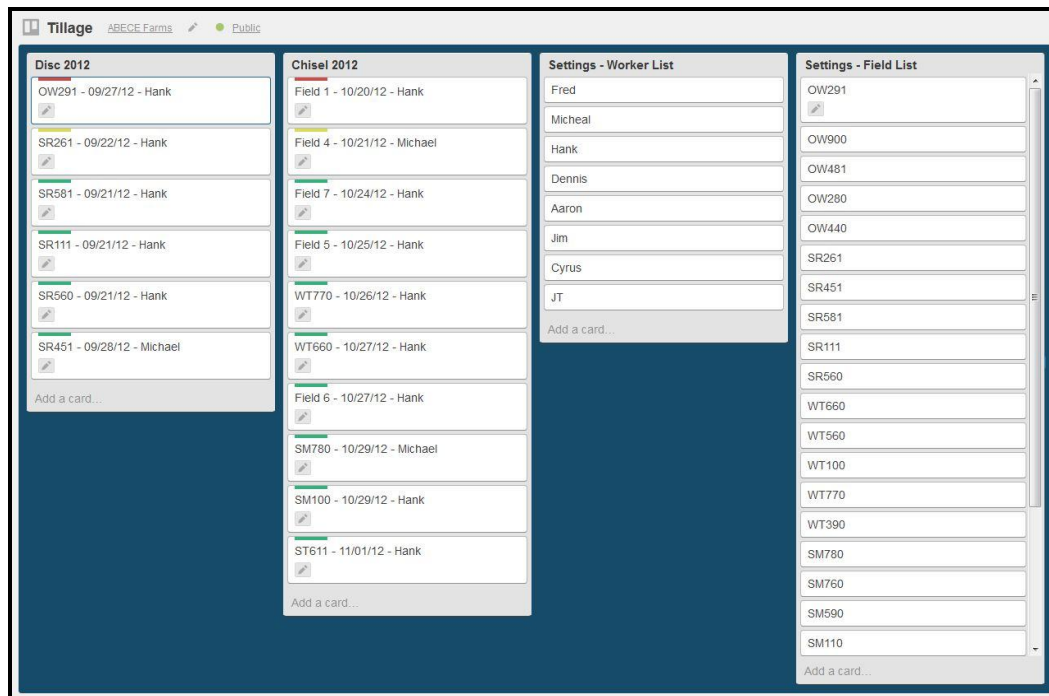

Figure 19: Trello board for the Tillage App with a list for Disc 2012, Chisel 2012, Settings – Worker List, and Settings – Field List.

Trello provides a feature to give individual cards colored labels which can each be given a name, such as Planned, Started, Done, etc. Trello also has a feature to filter cards based on text, label, due date, and others. The Tillage board can be filtered by label to include only cards which have the label “Planned” or “Started” to give the user a quick and easy method to see what tasks remain incomplete.

Figure 20 shows the back of a card from the Disc 2012 list in the Tillage App board. Note how the app organizes other tillage information into the card description.

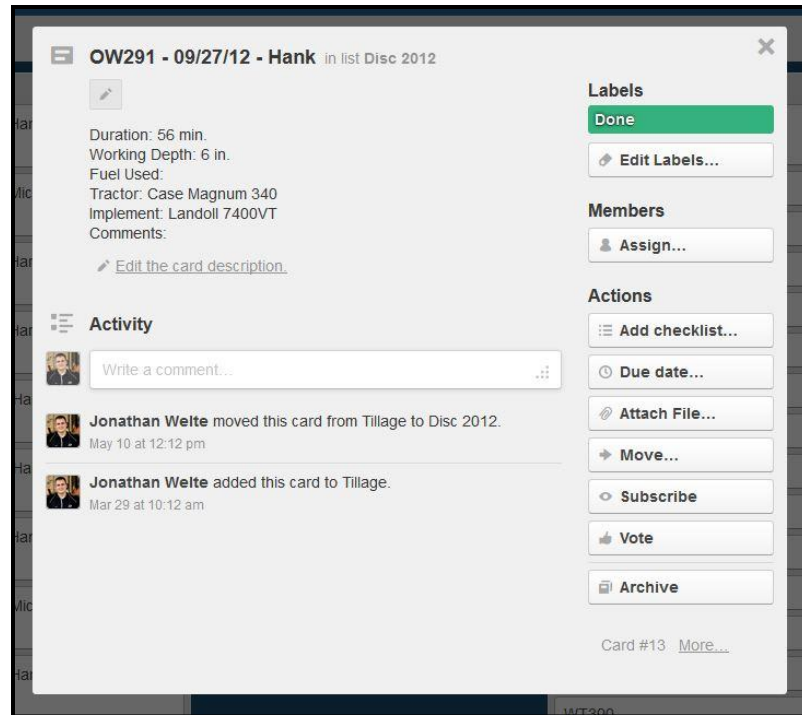

Figure 20: A view of the back of the card “OW294 – 09/27/12 – Hank” showing the tillage information stored in the card description.

#### 4.4 OpenAgToolkit Apps

The OpenATK model focus on simple, task-specific software led to the creation of a suite of apps. The recordkeeping focused on capturing the answers to the questions “who”, “what”, “when”, “where”, “when”, and “how”. Consistency in interfaces between apps helps users feel instantly familiar with a new app and reduces the time necessary to become proficient. Figure 21 shows how interface components were reused through the collection of apps.

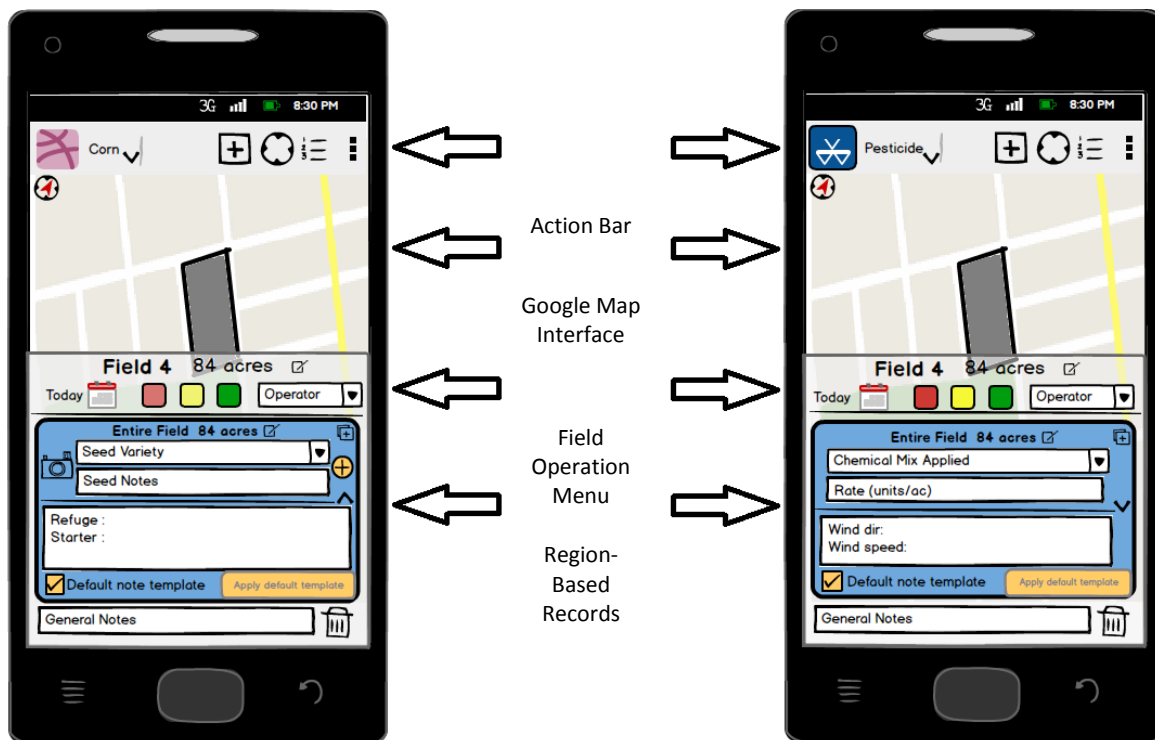

Figure 21: UI components are reused throughout OpenATK apps, Planting App (left) and Spraying App (right), to give the user an immediate feeling of familiarity when using a new app.

The action bar was implemented according to the Google Developer API Guide (Google, 2014 b.). The app icon is located on the far left to give the user a sense of location. The operation type label is just to the right of the icon, and it provides the answer to the “what” question. This label is a drop-down menu with functionality to let the user switch between operation types within an app. Some examples of operation types for the Planting App include “Corn 2013”, “Beans 2013”, “Wheat 2014”, and others which are flexible allowing for customization.

The action bar is the preferred location for action item buttons that are consistent throughout the UI. In addition to the app icon and operation type drop-down menu, the

three action item icons located on the action bar in Figure 22, include, from left to right, “add new field”, “move map to user’s location” (if a GPS location is available), and “change the map view to the list view”. The icon that is three stacked dots is the action overflow icon which is consistent with other Android apps. All action items icons that either don’t fit on the action bar or are programmatically assigned there will appear in a drop-down list if that icon is selected.

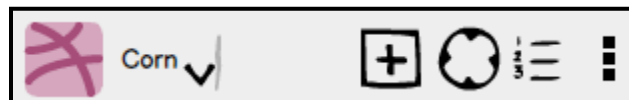

Figure 22: An example action bar used in the OpenATK Planting App mockups. The items on the action bar, from left to right, are the app icon, operation type drop-down list, add new field, move map to user’s location, switch to list view, and action overflow.

The Google Maps interface, Figure 23, is used to provide the base image for UI and gives location context to the user. The Google Maps interface was implemented according to the Google Developer API v2 guide (Google, 2014 h.).

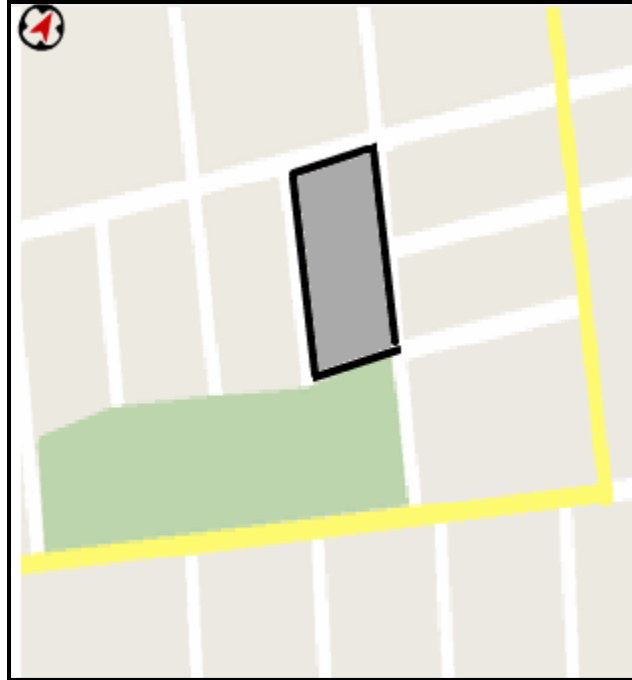

Figure 23: An example mock up with the Google Maps interface that is consistent across all OpenATK recordkeeping apps for field operations.

The field operation menu, Figure 24, gives the user an efficient means to note the important details pertaining to field operation records. It provides the “who”, “when” and “where” details for the operation record. The details are easily corrected which facilitates predictive and reactive scheduling. This menu slides up from the bottom of the screen and is only visible when a field is selected. The field name and size appears on the top row of the menu that corresponds to the field selected. The bottom row holds the date, operation status (Red for “Planned”, Yellow for “Started”, and Green for “Done”), and a drop-down list for the operator’s name.

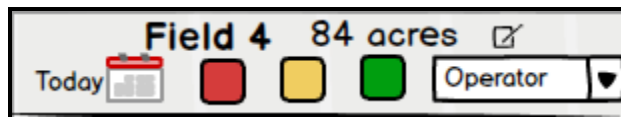

Figure 24: The field operation menu mock-up to assist the user with recording the “who”, “when” and “where” details for an operation.

Some users might prefer to keep more detailed records of field operations. The region-based record, shown in Figure 25, provides the functionality to take more detailed notes and document any variability in the operation across the field. This section captures the details for “how” an operation was completed. The region-based record is divided into two note sections. The top section is more structured with text boxes for operation specific notes. The example in Figure 25, from the Planting App mockups, contains a drop down menu for selecting the type of seed planted and notes about that particular seed type. The ability to take a picture of the seed bag tag proved to be a quick and useful way to record the seed information. This functionality is available by tapping the camera icon. A thumbnail picture of the tag replaces the camera icon after an image is captured.

The second part of the region-based record is an unstructured note area to accommodate any type or length of note needed by the user.

Figure 25: An example mock-up of the region-based record for the OpenATK Planting App. The top section of the record is specialized for the specific operation. An operation specific note for planting is what type of seed was planted, which is a common note for many farms.

Many record-keeping tools currently available try to apply the same note template to every field operation, and even if the note template is specialized for a particular field operation the entry fields do not fit every situation that arises in a typical growing season. The OpenATK approach is to allow the user the ability to take completely unstructured notes so that the UI does not become a burden to the user. The text entry interface can suggest note fields with predictive text. An example of this is an operator types “Refuge...” in the note area on Field 4, and when the operator starts to type a note for another field starting with “R” the text entry interface would suggest “Refuge”. This suggestion could be accepted by the user through various responses with the interface.

These UI components should be developed in a library so that future app development will be able to easily recreate the same look and functionality. This will also facilitate UI updates across the collection of apps because any change in the library will be reflected in the individual apps using the library.

#### 4.4.1 Tillage App

As discussed in previous sections, the Tillage App provides a simple means of managing data pertaining to tillage operations. Currently, this app keeps a record of tillage operations for a list of fields with statuses of “Planned”, “Started”, or “Done”. Also, each record contains the date of last status change, the name of the operator, and comments. Each field also has an optional associated boundary polygon which is shaded according to the operation status. Figure 26 was the final mockup before app development started.

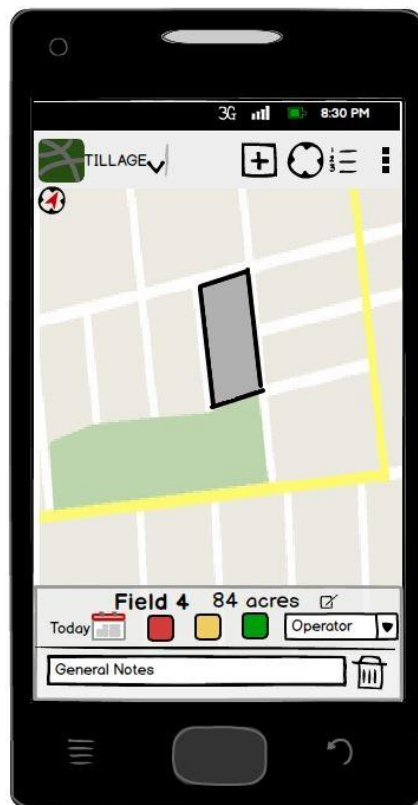

Figure 26: The final Tillage App mockup before code development began.



Figure 27 shows a screenshot of the UI in a typical use scenario. Four fields are saved in the Tillage App with two fields marked as “Planned”, one marked as “Started”, and one marked as “Done”. The Smith 56 field is selected and marked as “Done” indicated by the check in the “Done” box and the green shaded boundary polygon.

Currently, all data is manually entered by a member of the farm organization. The local cache is synced with Trello using the same algorithm as the OpenATK Trello library in Android. Future versions could incorporate methods to analyze GPS data to determine when a tractor with a tillage implement enters the field and starts driving in the field at a slow, relatively constant speed. When the app observes these operation parameters, it could automatically mark the operation status as “Started”. When the app observes that the equipment has exited a field after it covered the entire field, the operation status could automatically be marked as “Done”.



Figure 27: Screenshot of the Tillage App UI (V1.3) in a typical use scenario. The 56 acre Smith 56 field is selected and the menu allows the operator to record the date the operation was completed, his/her name, and any comments about the operation.

The field operation data and notes can be synced to the Tillage App board on Trello through the use of the Trello Sync App. Figure 28 shows a screen shot of a Tillage App Trello Board. There is a one-to-one relationship between the OpenATK apps and their respective Trello boards so that information can be viewed in either interface. Each operation type has a list, and each card on that list is an operation that is planned, started, or done for that respective operation type. The front of each card also shows the operation status, the date it was completed, the field name, and the operator's name. Additionally, the app stores other UI data on Trello. For the Tillage App, it stores a

list of operators to populate the drop down list, and a list of fields with boundaries to show on the map.

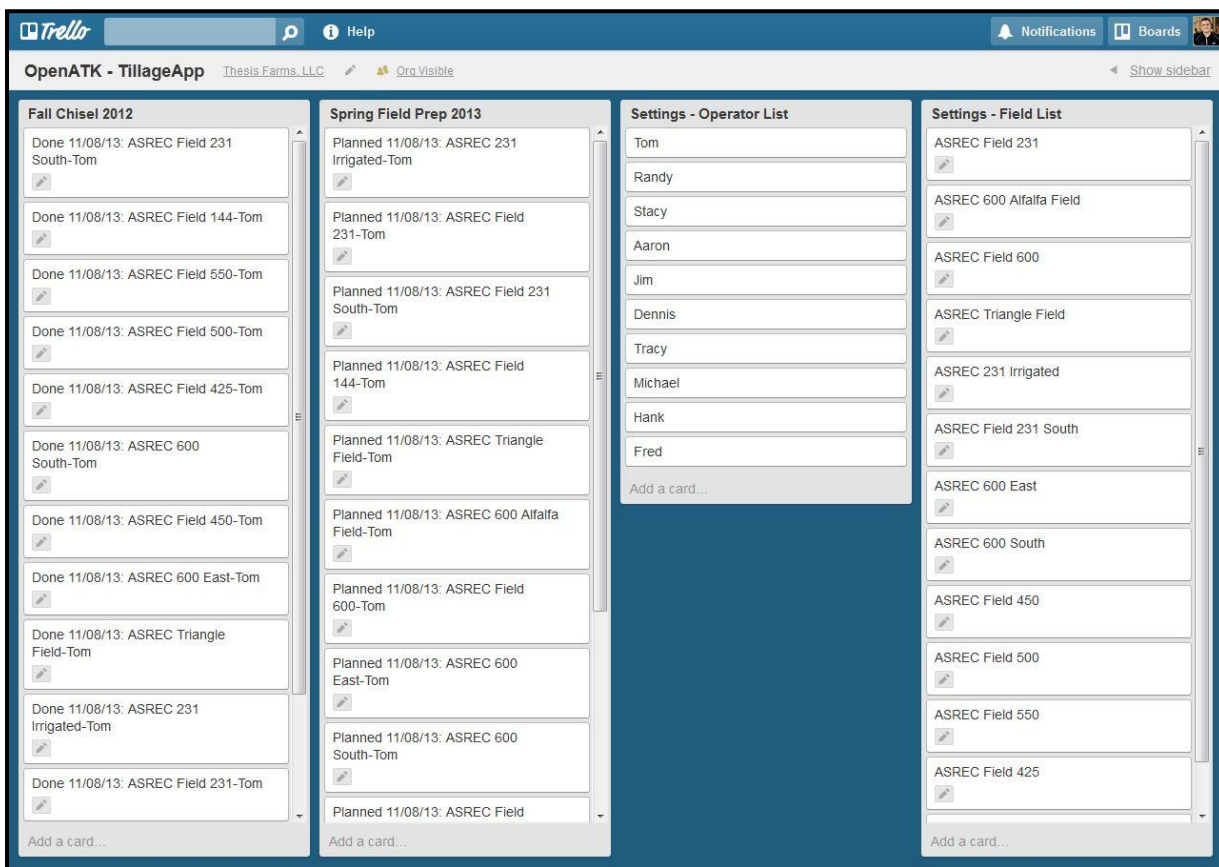

Figure 28: A screenshot of the Tillage App Trello board with a list for Fall Chisel 2012 and Spring Field Prep 2013 and two lists which store information for the app. The Operator List saves a card for each operator drop-down list and the Field List saves a card for every field in the app.

#### 4.4.2 Planting App

The task of the Planting App, similar to the Tillage App, is to record information during planting season, and make those records available whenever they are needed. The data entry task is slightly more cumbersome due to the nature of planting notes, but this task has been simplified where possible with drop-down lists. Unlike tillage operations where

the same treatment is applied across the entire field, planting operations often vary from one side of the field to the other and even across the width of the planter. Planting operation notes can include details about the seed planted, seed population, fertilizer applied, and more. The local cache is synced with Trello using the same algorithm as the OpenATK Trello library in Android.

As shown in Figure 29, the Planting App provides a simple means of recording relevant information after an operator finishes planting a field. Besides recording the name of the operator and the date, recording the seed type is a fairly common note field. To simplify this task a drop-down list was implemented that contains the list of seeds the farm has used in the past. Another burdensome task deals with entering information from the seed bag tags. To simplify this task, the user is able to take a picture of the tag. The app saves the picture, and the UI displays it as a thumbnail. Any other notes that the operator wishes to take can be entered into the free-form text box. If an operator finds himself taking the same notes for every planting operation, he can designate those notes as the template by checking the box below the free-form text box. For every subsequent field, he can press the button on the bottom right “Apply default template” to expedite the recordkeeping task.



Figure 29: The Planting App mockup is shown with Field 4 selected. The operator can make records for the current planting operation and then mark the field as done.

Figure 30 shows an example Planting App Trello board. The board is organized with lists for Bean Planting operations, Bean Varieties, Corn Planting operations, Corn Varieties, and Web Controls. The operation lists provide a record of planting operations for the farm. The varieties lists expedite the recordkeeping process by attaching pictures of the seed properties rather than requiring the user to input each piece of information (Ault et al., 2013).

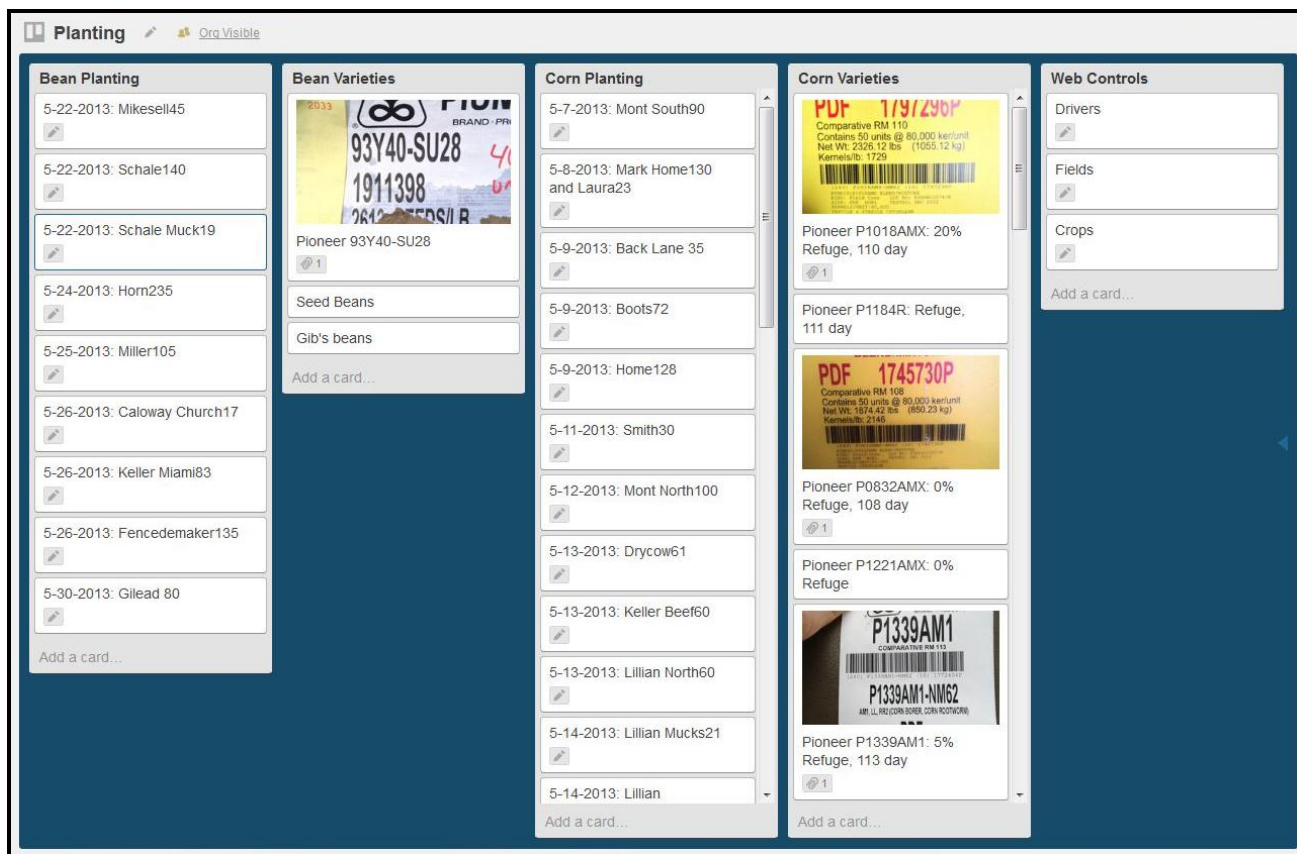

Figure 30: Example Trello board containing planting records from Ault farm for 2013. These were all entered by the operator using an iPhone or iPad while in each field.

#### 4.4.3 Rock App

The Rock App provides a UI to easily mark the location of rocks for removal. When an operator marks a rock, its location is shared with other devices on the farm by syncing its location to Trello so that it can be removed quickly. Another operator is likely responsible for the removal of the rock, and marks it as "Picked Up" once it has been removed. The location of rocks can also be shared with other apps where appropriate. An example of another app which would benefit from knowing the location of rocks in a field would be the Tillage App. An operator should be shown the location of rocks in a

field before a rock causes damage to an implement. Figure 31 shows a Rock App UI mockup on an Android device. Rock marker icons are placed on a Google Maps interface; gold for in the field, gray for removed. When a rock marker icon is selected, the menu slides up to allow the user to mark it as removed, take a picture or add a note about the rock. This UI mockup shows a list view icon in the top right of the screen. This feature is not currently implemented on the Rock App. However, given enough interest from users, it could be easily implemented.



Figure 31: The Rock App mockup showing three rock marker icons on a Google Maps interface. The rock marker icon in the top left is selected and the menu allows the user to add a note, take a picture, or mark the rock as removed.

Figure 32 shows a screenshot of the OpenATK Rock App UI with rocks marked in a field. Rocks can be added to any location and moved on the map regardless of the user's location. When a rock icon is selected, the menu allows the user to mark the rock as "picked up", attach a picture and add a comment. As the map view is zoomed out, the rocks are grouped together with nearby rocks and a number icon appears indicating how many rocks are grouped together.

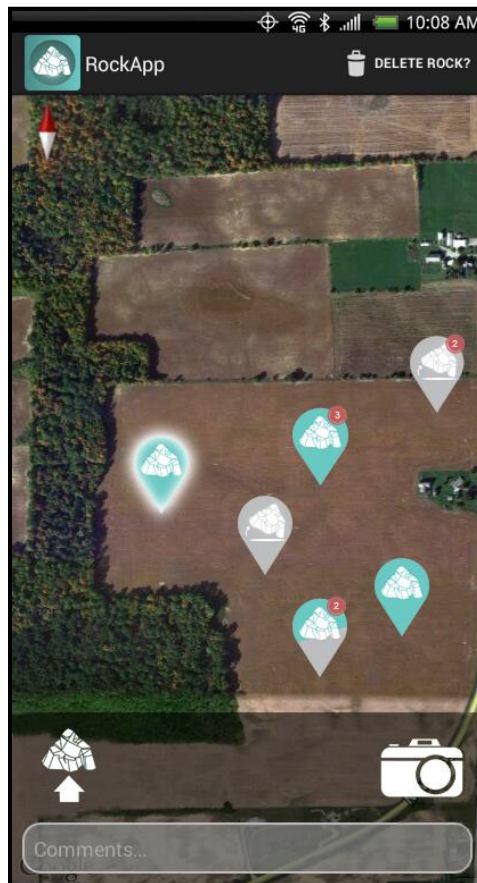

Figure 32: Screenshot of the Rock App UI (V1.3) showing five rocks marked for removal and four rocks marked as picked up.

Figure 33 shows the Rocks Trello board with a card for each rock on the appropriate list, "Rocks In Field" or "Rocks Picked Up".



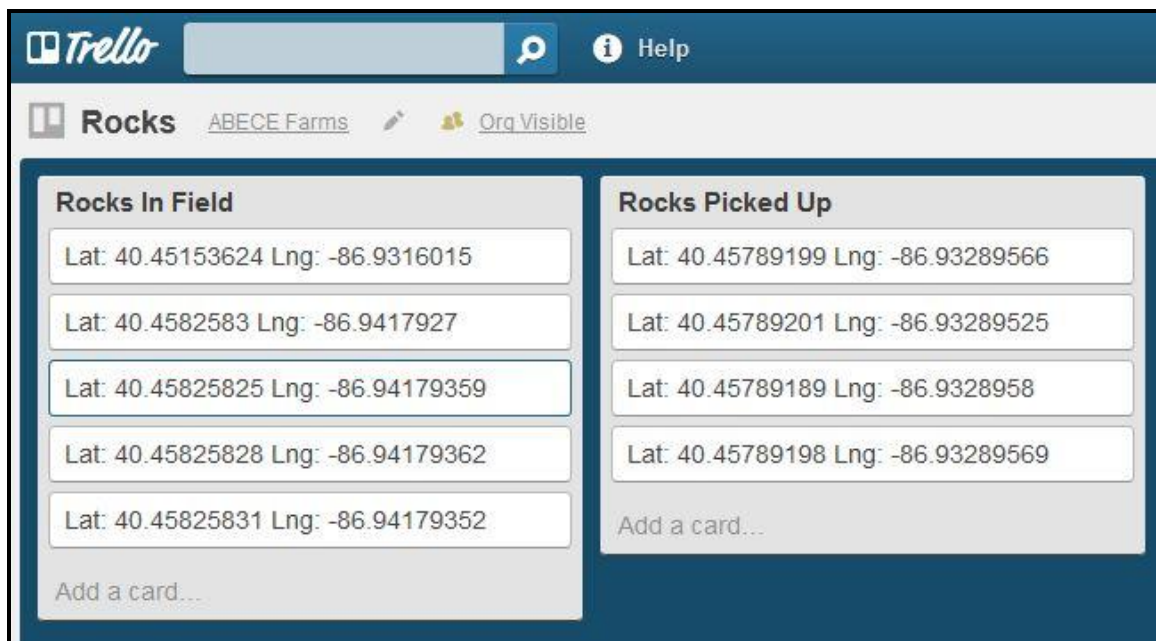

Figure 33: Screenshot of the Rock App Trello board with an individual card for each rock; five on the “Rocks In Field” list and four on the “Rocks Picked Up” list.

#### 4.4.4 Field Notebook App

The Field Notebook App was developed to help farmers keep general notes about their fields. Often, field notes are scattered throughout “dashboard” and “pocket” notebooks if they are recorded at all. It’s very easy to make a mental note of an observation, but the mental note is rarely remembered or shared with other farm employees. This app can solve these problems because it provides a centralized location for field notes and can also be synced to Trello.

The Field Notebook App is primarily responsible for maintaining a list of fields on the farm and providing that list to other field operation apps locally that could benefit from that information. Along with this responsibility, the app provides the functionality to record manually entered notes with associated polygons, polylines, or location pins.

Figure 34 shows the Field Notebook App UI on a full size tablet screen. Because of the increased screen size, the UI is able to place the field list and Google Maps interface on the same screen eliminating the need to switch back and forth between list and map views.

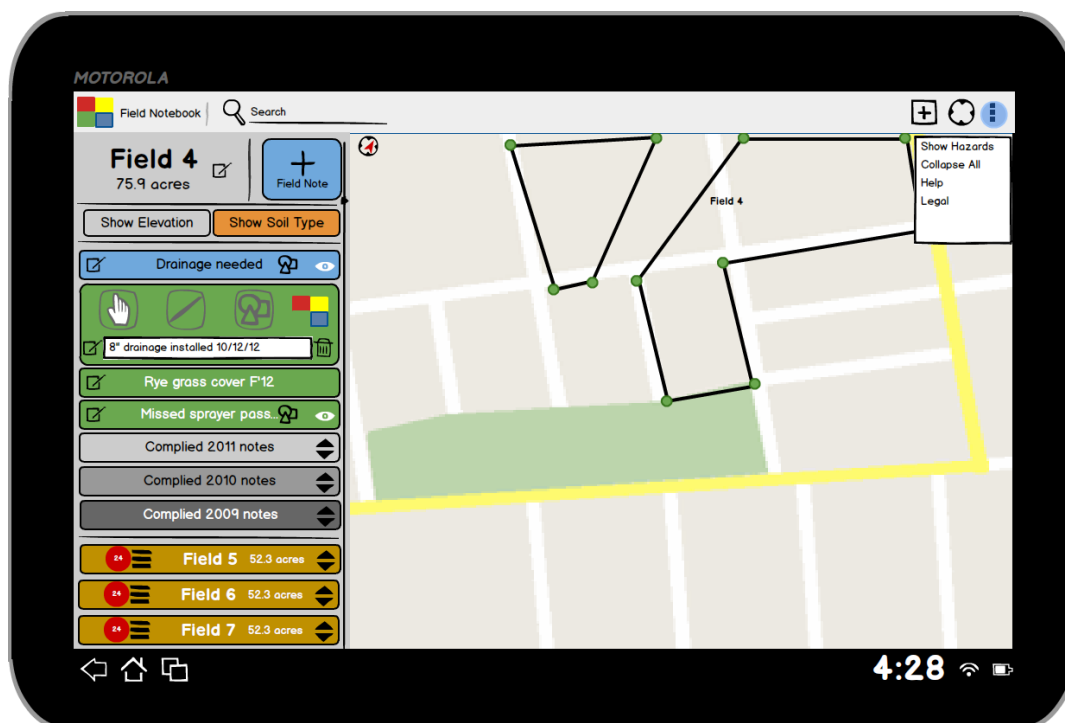

Figure 34: The Field Notebook App UI mockup with Field 4 selected. The field list shows every note associated with Field 4 in a scrollable list.

Figure 35 shows a screenshot of the Field Notebook App running on an ASUS Transformer tablet. With Field 4 selected, the app displays the three notes associated with the field. One note (red) showing areas of the field where corn leaf necrosis was found, one note (yellow) showing the path walked for crop scouting, and one note (green) showing locations in the field leaf tissue samples were taken.

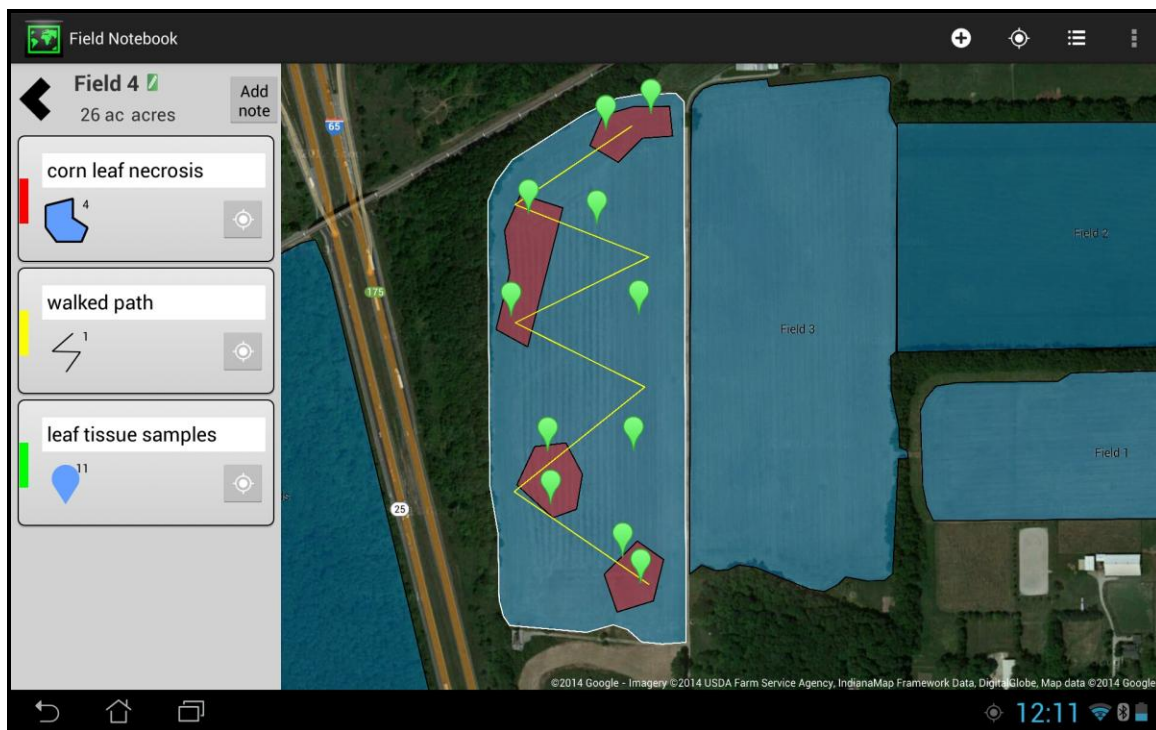

Figure 35: The Field Notebook App UI (V1.0) shown with Field 4 selected. The Google Maps interface shows the three notes associated with Field 4. One note (red) showing areas of the field where corn leaf necrosis was found, one note (yellow) showing the path walked for crop scouting, and one note (green) showing locations in the field leaf tissue samples were taken.

While this is not intended to be an exhaustive list, the Field Notebook App could be used to document and share information such as:

- Tile routing
- Utility locations
- Wet spots
- Weed infestation
- Changes in crop conditions

#### 4.4.5 Trello Sync App

The Trello Sync App allows the user to specify which OpenATK apps will synchronize with Trello for free backend cloud storage. The app is responsible for retrieving and providing Trello authentication information to any other app which requests it through the use of a content provider. Some level of human administration is required regardless of the design of the system. For a farm without a pre-existing Trello organization, the Trello Sync App assists the user with setting up the farm organization and selecting members. The Trello Sync App does not maintain a Trello board or use any other cloud storage service. A screenshot of the Trello Sync App (V1.1) is shown in Figure 36.

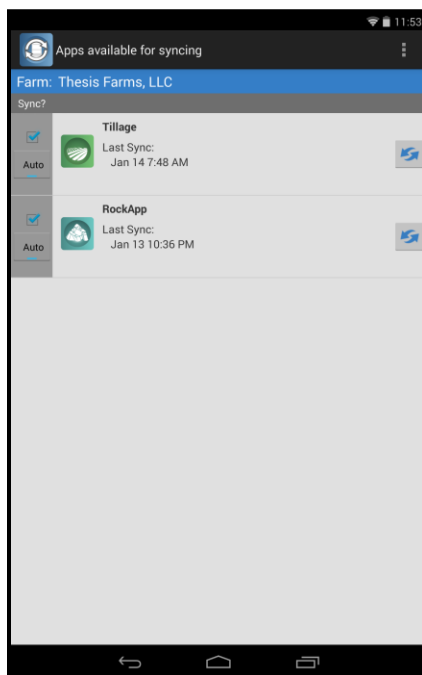

Figure 36: A screenshot of the Trello Sync App (V1.1) where the user can select which OpenATK Apps should be synced to Trello. The screenshot shows the Field Work, Rock, and Tillage Apps all syncing to Trello indicated by the checkmark to the left of the app icon.

The Trello Sync app is solely responsible for keeping the local database and the cloud storage synced. An update is triggered five seconds after detecting a change in a local database. It also looks for updates in cloud storage since its last sync that it needs to pull down to update the local app database. It checks the cloud storage for changes since its last local database sync at least every 30 seconds in the case that another user has updated the cloud storage but no change locally triggered the sync function. Users of the Trello Sync App are able to disable the automatic update if they are concerned about battery or data usage. However, if it does not find an update from the Trello website the data usage would amount to approximately 50 bytes per attempt. This would amount to approximately four megabytes/month, or the amount of data to download a four minute long MP3 song.

This manual check for an update of the cloud storage is necessary because the Trello API does not currently support the push function for mobile devices. This feature, which is currently available on web app and the native Trello app, would push updates to the cloud storage to all users, and thus, eliminate the need for the apps to manually check for updates.

#### 4.5 OpenATK Apps Currently In Development

The list of ideas for apps in the OpenATK suite continues to expand. These require resources, so prioritization based on need is required. The list includes apps for many aspects of farm management including equipment maintenance, grain hauling, human

resources, and more. The following sections outline some basic features and UI mockups for potential OpenATK Apps.

Similar to the Planting and Tillage Apps, the Anhydrous and Spraying Apps are very quick and simple apps used to plan and record the application of anhydrous ammonia and spray applications in fields, respectively. While still in an early phase of development, Figure 37 shows how many of the UI components are consistent with the other field operation apps. The primary change deals with operation specific data in the region-based record area. In the case of the Anhydrous App, the farmer would like to keep track of the anhydrous tanks he/she purchased and the amount of anhydrous ammonia that was applied to each field. In the case of the Spray App, the farmer needs a simple way to keep track of spraying applications including amounts and contents of blends sprayed on the field. Date and user stamping of information saved by these apps is a key aspect of complete record keeping.



Figure 37: Early mockups of the OpenATK (a.) Anhydrous App and (b.) Spray App used to help farmers keep better records of field operations. Many UI components are reused for a consistent user experience and instant familiarity.

#### 4.6 Summary

The progression toward information-driven agriculture necessitates an approach to FMIS which can adapt to different farming operations and provide farmers with long-term ownership of their data.

Farm management and operational data should be accessible and understandable outside the apps (which collect the data) themselves to better facilitate true data

ownership by the farmer. The hope is that task-specific apps will lead to better, more intuitive designs that are likely to be of interest on many farms. This approach will also help keep the learning curve low for other developers and farmers who may wish to contribute to the project whenever a new use case arises. It is the backend of implementation which will lend the largest value to the data collected.

The OpenATK model proposed and developed here-in is novel in several respects (Open Ag Toolkit, 2013):

- Use of existing (often free) cloud storage: this dramatically lowers the startup cost to farmers, many of whom may already be using one of these services.
- Non-binary formats: data is always represented in human-readable form in the backend. Great care goes into designing the storage format in ways that farmers would naturally have chosen themselves in the absence of the app. It should be quite simple for farmers to correct errors. Each app is therefore designed to be highly tolerant of errors in backend data formats which might result from inadvertent modifications.
- Task-specific, user-centered design: by limiting each app to solving one particular problem, simple usage scenarios for real people can be used to help ensure that each final app is intuitive. The primary design goal of each app is for people unfamiliar with the app to be able to use it without the need for a user manual. For developers, this allows them to design their app completely independently of other apps for their particular task, and then add in collaboration only where it makes sense to do so.
- Collaboration among apps: If App A needs data that App B is responsible for, A will request it from B. If B does not exist on the mobile device, then A is designed to fill the data void intuitively until which time a user may decide that App B would be useful.
- No required apps: many FMIS systems require a farm to modify their internal operations in order to fit the predefined FMIS model. The OpenATK approach allows people to use any combination of apps that they find beneficial. For example, the Tillage App records the name of the operator who performed tillage. However, a “People Manager” app may be uniquely responsible for handling information about people on a farm and sharing it across many apps. If



a particular farm only uses the Tillage app and no other apps, they have no reason to use the People Manager app. Therefore, until a People Manager app is installed, the Tillage app simply maintains a list of possible operator names.

- Embracing Heterogeneity: since many apps can be written to solve the same task, there is no need for one app to work for all farms in the world. Some farms may find a general Planting App useful, whereas other farms may find a Peanut Planting app suits their needs better.

The collection of apps allows each farm to put together a highly usable, tailored data management solution to improve production agriculture in the future. This structure also provides an intuitive and robust interface and data structure for farm and field metadata.

## CHAPTER 5. METHODS TO DETERMINE TECHNICAL VIABILITY AND INTERFACE USABILITY

### 5.1 Technical Viability

The technical validation of the proposed system was carried out in two phases. First, the user interfaces were individually validated. Then, a subset of the suite of apps was created to validate the essential functions of the OpenATK model.

Individually, the apps were verified against the functional specifications. The UI must provide the functionality to accomplish the tasks and goals described in the user stories created earlier. The individual task-specific apps can be considered technically viable when this functionality is realized.

The system validation required the creation of several apps to test the technical viability of the OpenATK model. The user needed the ability to create or collect farm data within the apps that were previous verified individually, and then, share it with other apps locally and other users on the farm network using wireless data transfer and cloud storage services. The OpenATK model with task-specific, collaborative mobile apps and cloud storage services can be considered technically viable when the previously mentioned tasks are accomplished.

## 5.2 Estimating Data Storage Needs

The designed system should be able to support the expected data load with respect to data transfer and data storage – both to and from cloud storage as well as locally. A set of artificial data was entered through the apps to verify the technical viability of the system. For this storage needs test, artificial data for the simple scenario of a 404 ha (1,000 acre) farm with 10 operators and six operations per field was entered for one year. All 404 ha (1,000 acres) received the same field operation set (and associated data) to simplify the simulation.

The test farm included 404 ha (999 acres) in 13 fields for an average of 31 ha/field (76.8 acres/field). These fields were of realistic size and shape and varied from 3 to 83 ha (7 to 206 acres) with 12 to 110 latitude/longitude vertices on their boundaries with an average of 41 vertices/field. Figure 38 shows a screen shot of the Tillage App with the fields used for this study. A comparison of size of the field to how many vertices defined its boundary showed no correlation between the two variables. The total number of field boundary vertices was 528. The operator list included 10 names. The field operations included six operations: Spring Field Prep 2013, Corn Planting 2013, Side Dress N 2013, Spraying 2013, Harvest 2013, and Disc Fall 2013. A different operation type within the Tillage App was used for each field operation because the individual apps were not available yet.



Figure 38: A screenshot of the Tillage App showing the 13 fields used for this study.

The Android OS setting menu displays the amount of data stored locally by each app.

The amount of data displayed stored locally in the Tillage App was recorded after completing the 404 ha (1,000 acre) simulation. The system components used to test the technical viability of the system included:

- Google Nexus 7 tablet running Android (V4.4.2)

- OpenATK Tillage App (V1.3)
- OpenATK Trello Sync App (V1.1)
- 802.11n Wi-Fi and high-speed broadband cable internet
  - approximately 29 Mb/s download speed and 6 Mb/s, upload speed
- Trello cloud storage

The Trello website was viewed on a desktop PC with internet connection to observe the changes to the Tillage App Trello board as the artificial data was entered.

The farm's Trello organization was set up using the Trello Sync App. The Trello Sync App synced the Tillage App board with the local database every five seconds after a change was detected in the Tillage App database. Changes in the app were reflected on the Tillage App Trello board within seconds. Although not explicitly tested in this research, it is assumed that the OpenATK Trello Sync App should also work over cellular data networks because the OpenATK Apps are within cloud storage capabilities of Trello and the native Trello app is able to sync data over cellular data networks.

### 5.3 Usability Study

Usability studies enabled product developers to gain valuable feedback on the product from users throughout the design process, all the way up to the public release. The results of the study helped predict the likelihood of success upon final release by determining if the product in development was relevant and had a promising future. The studies helped develop usability criteria that served as the guidelines through the design process (Norros, et al., 2009).

There are multiple methods to evaluate usability. The correct selection can change through the project development phases, and often depends on the development phase, complexity of user interaction and available resources (Haapala, et al., 2006). The following sections discuss some of the evaluation methods used for this project.

#### 5.4 Weekly Usability Check

The most basic testing often provided the most insight for the lowest effort put towards verifying progress; find a couple of users, ask them to test the interface, and observe what they do. Make notes where the users succeed and where they fail. Unlike the more formal pre-release testing, these tests were very informal and often only focused on the most recent UI changes. This type of limited scope, quick turnaround usability testing is called hallway or cubicle testing; named for the locations where this type of testing usually occurs.

The testing involved new and returning users. Just about anyone with a couple minutes to spare walking around office or sitting at his/her desk is qualified to be a user (Krug, 2006). Each test which lasted from ten to thirty minutes in duration was conducted on a varying schedule depending on the magnitude of changes made to the interface. The tests were always run weekly, and occasionally these tests were run daily. Office cubicles or vacant conferences rooms were the most common locations for these tests. Due to the limited scope, the results of these tests were immediately communicated to the developers and were rarely documented for further analysis.

## 5.5 Pre-release Testing Procedure

The most basic usability testing often provides the most insight for the lowest cost. Our simple approach was to gather a group of representative users, ask them to perform representative tasks, and observe what they did. We noted where the users succeeded and where they failed. We tested the users individually and let them solve any problems on their own because if the interviewer helps the user or directs his/her attention to a particular interface feature, the test results have been contaminated (Nielsen, 2012).

### 5.5.1 Recruiting Potential Participants

Recruiting potential participants required the identification of members of each user group. Senior students in the Agricultural Systems Management (ASM) major at Purdue University were likely to have experience as equipment operators, and would possibly return to an equipment operator role following graduation. These ASM seniors currently represented the user group with Farm Hand Hank and will likely become Manager Mike in the near future. This email distribution list was available from the Agricultural and Biological Engineering support staff as a listserv. The invitation to these students indicated that participation was voluntary and was, in no way, connected to any course or degree requirements. The recruitment email to the potential ASM student participants can be found in Appendix B. Employees at Purdue Agricultural Centers (PAC) were identified as potential participants because of their experience working with farm decision making and recordkeeping. These employees represented users from all three user groups based on their role and job description. The Purdue Ag Center employees

were identified as Purdue employees who manage research farms at Purdue; they are identified from these publically available sites:

- <https://ag.purdue.edu/arp/pac/Pages/default.aspx>
- <https://ag.purdue.edu/ansc/Pages/ASREC.aspx>

The recruitment email to the potential PAC employee participants can be found in 0. All participants were notified that their participation was voluntary, and that they could refuse to answer any questions or withdraw from the interview at any time. Subjects were informed that there was no compensation for their participation.

### 5.5.2 Location

The location for the study was selected based on availability and convenience to the participants. While the location of use is likely to vary on a real farm from a tractor cab to the office desk, an office or small conference room better facilitates the needs for the observational study. The environments of expected use are full of distractions which would hinder the user's ability to concentrate on the software. However, since these distractions would not be consistent for each user in the study, the locations of the usability study were chosen to limit distractions as much as possible for more consistent results.

### 5.5.3 Personal Interview

Prior to the start of each personal interview, the participant was instructed to read through the consent form before signing it on the last page. The Purdue Institutional Review Board (IRB) approved consent forms for the ASM student participants and PAC employees can be found in 0 and Appendix E, respectively.



The personal interviews consisted of four main sections and lasted no more than one hour in length. It was important to avoid divulging too much information throughout the interview to avoid contaminating the results. The participants were informed early on in the interview that the interviewer was there to lead the session and observe. This let them know that the interviewer might not be able to show agreement or provide assistance. The Purdue IRB approval letter (#1310014085) can be found in Appendix F, and the approved personal interview script can be found in Appendix G.

The introduction was intended to give the participant more information about the study. It also informed the participant of his/her rights to withdraw or abstain from answering any questions. The introduction informed the participant that the software was being tested and not the individual's abilities, which helped reassure him/her that "mistakes" were expected and completely acceptable.

Next, the participant was asked a series of open-ended questions about his/her background. This not only helped the interviewer better understand the participant's experiences, but also helped initiate an open conversation to be carried through the interview. Questions were selected to gain information about the participant's background, farm experience, and opinions of current technologies.

Then, the participant was then shown the OpenATK apps one at a time installed on an ASUS Transformer TF700T tablet (10.1" 1920x1200 resolution HD screen) running Android Version 4.2.1. For each app tested, the participant was allowed to look at the UI while he/she was asked a couple questions before anything was explained. The purpose of these questions was to see how much the participant could understand solely by

visually scanning the UI. If the UI provided the correct context, the user should be able to use the basic features of the app without any explanation. Explaining the UI before asking any questions would give more context to the user. To facilitate the discussion each participant was asked to describe what he/she would try to do first, if anything stood out on the UI that might be important, and if the function of each button could be explained. After a short description of the app, the participant was asked to complete several specific-tasks. The interviewer's job here was observing the attempt at each task, noting where the participant had difficulty.

#### 5.5.4 Ensuring Participant Confidentiality

The raw data were audio recordings. The purpose of the recording was to help the development team accurately understand the results of the interview. However, the recorded voices serve as a personal identifier. Audio recordings were transcribed and destroyed within 30 days of completing the interview. Notes taken by the interviewer did not include identifiable information. The risks to participants in the event of a breach of confidentiality were very low. The nature of the information collected and storing caused very little threat in the event of a breach. The information collected pertained to app usage and value, NOT the data entered into the app.

The software did not ask for any personal information. User accounts were not required to use any of the apps. While the apps were able to synchronize to cloud storage services this functionality was not tested, and was disabled. If for any reason some data was uploaded to cloud storage, it was deleted along with all data store locally on the devices immediately following the interview.

The participants were instructed to enter hypothetical data. If, for some reason the participant responded with, or entered identifiable information, it was de-identified before transcription. The only documentation of participation was the signed consent forms; it is virtually impossible to match the consent form to the participant responses. The raw data in the form of transcriptions were stored. Saving this information is important so it will be stored indefinitely. The interview transcriptions, notes and consent forms will be stored in a locked file with restricted access. Future uses of the stored data may include comparing future app versions, and verifying improvements.

#### 5.5.5 Study Assumptions

The following assumptions were made to guide the usability study procedures and analysis:

- The personal interview participants were representative users
- Each participant was able to comprehend the verbal instructions for each task
- Each participant had an equal opportunity to complete the given tasks
- The participants responded with honest answers and feedback

#### 5.5.6 Study Limitations

The following limitations were identified with regard to the usability study:

- The personal interview participants were limited to farmers from northwestern Indiana
- The study consisted of one round of testing with four participants

- The study did not account for differences in previous knowledge between participants
- The participants had no previous experience or exposure to the user interfaces being tested (i.e., no tutorial or help guides were provided prior to or during testing)
- The participants potentially lacked motivation to complete the task because they did not choose to download and use the apps

#### 5.6 List of OpenATK Apps Tested

The following list details the versions of the four OpenATK apps and the specific tasks that the participants were asked to complete during the personal interview.

- Rock App (V1.3)
  - Move the map to show user's location
  - Add a rock marker to the map
  - Move the new rock marker to some other spot on the map
  - Mark the rock as picked up
  - Show all rock markers, including those picked up
- Tillage App (V1.3)
  - Move the map to show user's location
  - Add a new field to the map named "Field 2020"
  - Make an operation record for the new field to reflect the completed tillage operation on November 10<sup>th</sup>, 2013 by John

- From the List View, change the operation date for the new field to November 18<sup>th</sup>, 2013
- Planting App (V1.3)
  - Move the map to show the user's location
  - Add a new field to the map named "Field 1234"
  - Make an operation record for the new field to reflect the completed planting operation on May 10<sup>th</sup>, 2013 when Tom planted Hybrid XY with refuge in the bag at 30,000 seeds per acre and five gallons of starter fertilizer per acre
- Field Notebook App (V1.0)
  - Move the map to show the user's location
  - Add a new field to the map named "Field 3030"
  - Add a note about a wet spot in the top left corner of the field
  - Add a note about three spots in the field where there are insect problems

## 5.7 Heuristic Evaluation of Usability

Nielsen (2001) recommended several usability metrics including success rate, the time required to complete each task, error rate, percentage of time users followed the correct path, number of times the user needed to backtrack, and user's subjective satisfaction.

Qualitative methods of usability testing often provide better insight for a fraction of the cost when compared to quantitative methods (Nielsen, 2001). Krug (2006) and Nielson

(2012) state that multiple rounds of testing are needed to find major and minor problems which could lead to expensive usability studies. Haapala et al. (2006) successfully implemented the heuristic evaluation method early in the design process for a virtual terminal (VT), and stated that it was suitable for an iterative design process. For these reasons, the heuristic evaluation method was selected for this research. The heuristic evaluation process described below was used following the procedure used by Haapala (2006).

First, a list of representative tasks for each app was generated independently of recruiting interview participants. Next, the participants were individually interviewed, and asked to perform the tasks for each app on the ASUS Transformer tablet without any assistance. Through the interview the proctor was able to take observation notes about the steps taken for each task. Next, the notes about each task and each participant were analyzed to find usability violations. Finally, the violations were categorized based on severity and root causes were discovered.

## CHAPTER 6. RESULTS OF TESTING AND USER FEEDBACK

### 6.1 Amount of Data Generated by a 404 ha (1,000 acre) Farm

Artificial records for a farm were created to determine if currently available technologies were capable of handling the amount of data generated by a farm throughout the year.

After entering the artificial data for the data usage test the Android OS settings reported that the Tillage App was storing 260 kilobytes locally. For comparison, just one minute of an MP3 music file is approximately one megabyte, which is almost four times larger. The amount of actual data associated with these records is minuscule.

The stored data falls into three groups: operators list, fields list (field boundary definitions), and operational data. The field boundaries were the largest contributor to the amount of the data generated in the app's local storage. This is because field boundaries are stored as a list of comma separated latitude and longitude coordinate values to fourteen decimal places. The shape of the fields has a huge impact on the amount of data generated. For example, a single 404 ha (1,000 acre) triangle would only have three latitude and longitude coordinate values. However, the fields used for the simulation in northwestern Indiana were often defined by waterways and roads, and thus, some of the fields boundaries were defined by more than 50 points.

## 6.2 Summary of Study Participants

This round of testing was conducted with four interview participants. The four participants consisted of two Purdue Ag Center employees, representing the Farm Owner Fred and Manager Mike user groups, and two seniors in the Agricultural System Management major, representing the Farm Hand Hank user group. The study consisted of one user with previous Android OS experience and all four participants had previous Apple iOS experience.

When asked how they used their smartphone for farming related tasks, all four participants replied with the relative normal smartphone functions: phone call, text messaging, email, notes, and pictures. Only two participants responded that they used agriculture specific apps: an app to calculate area from a map interface, an app to calculate tank mixes, and an app to see market information.

When asked about the current method of recordkeeping on their farm, all participants replied that their farm had a moderate to extreme reliance on pencil and paper notes. All of them were able to quickly describe at least one problem they've encountered with this method of recordkeeping. These issues ranged from lost notes to stacks of notebooks in the office when they needed them in the field. All four participants also described some in-cab electronic display with data storage capabilities. However, only two participants indicated that their farm took the effort to transfer the data to a desktop computer for long-term storage. Both of these participants acknowledged they could do more with the data, and only one of these participants was able to describe a



detailed situation where he used the data to make a management decision for the following year.

When asked about their comfort with storing farm information in cloud-storage services, all four participants indicated their level of comfort depended on the nature of the information being stored. Most participants expressed some level of concern about security when considering storing sensitive information in cloud-based storage such as financial information, etc. This information about the farm is not the type of information that would need to be stored in cloud-based services to be shared across all farm workers in real-time. The “who”, “what”, “when”, “where”, and “how” nature of this FMIS approach did not surface as a concern. It is highly likely that these participants store personal information in cloud-based services without realizing it. Therefore, more education about the many uses and benefits of cloud-based services should render this a nonissue.

### 6.3 Results of the Study

The results of the usability testing are summarized in Table 1. A green box with a checkmark indicates the participant was able to complete the task without any assistance regardless of the steps taken. A red box with an X indicates the participant was unable to complete the task without assistance. Interestingly, without any additional instructions more participants succeeded each time they were given a fresh start and asked to complete the add field task.

Table 1: Results from the usability study. A green box with a checkmark indicates the participant was able to complete the task without any assistance regardless of the steps taken. A red box with an X indicates the participant was unable to complete the task without assistance.

Participant	App:	Rock					Tillage				Planting			Field Notebook				
		Task:	Move Map	Add Rock	Move Rock	Pick-Up	Show All	Move Map	Add Field	Make Record	Change Date	Move Map	Add Field	Make Record	Move Map	Add Field	Add Note	Add Note
#1		✓	✓	✗	✓	✓	✓	✗	✓	✓	✓	✗	✓	✓	✓	✓	✓	✓
#2		✓	✓	✗	✓	✓	✓	✗	✓	✓	✓	✗	✓	✓	✗	✓	✓	✓
#3		✓	✓	✗	✓	✓	✓	✓	✓	✓	✓	✓	✓	✓	✓	✓	✓	✓
#4		✓	✓	✓	✓	✓	✓	✗	✓	✓	✓	✓	✓	✓	✓	✓	✓	✓

However, usability is more complex than simply recording successes and failures.

Efficiency, satisfaction, and the summation of errors are also attributes of usability. Thus,

it is necessary to record the steps taken to complete each task to discover usability

violations. The violations were categorized based on their severity considering the

frequency, impact on the user, and persistence of the problem. The following sections

describe the violations experienced and other items of interest found in the four

OpenATK Apps evaluated by the four participants.

The OpenATK Rock App was the furthest along in the development process of all the

apps tested. It has gone through more rounds of weekly tests, and it is also the most

task-specific UI of all the apps tested. Therefore, it should have received the fewest

critical violations and be the most usable relative to the other apps tested. However, it

was the first app tested and did not benefit from the experience gained by the

participants from using previous OpenATK apps.

### 6.3.1 OpenATK Rock App

Overall, the Rock App represented a fairly usable interface. One severe violation was found when participants were asked to move a rock marker icon. Three out of the four participants were unable to move the rock marker icon. Multiple participants discovered a simple workaround where they deleted the original rock maker icon and simply added a new one to the map in the new location. The correct procedure for moving a rock marker icon is to long-hold (also known as press and hold) on the rock marker icon. If successfully long-held, the rock marker icon would pop up on the map above the finger. The rock marker icon would then follow the finger anywhere on the map until the finger was removed from the screen. However, the long-hold method was relatively nonobvious to the participants, and a new method is needed to drag objects on the map.

### 6.3.2 OpenATK Tillage App

The Tillage App was the first app where participants were asked to add a field to the map. Directions and descriptive words were intentionally left out of the interview script to reduce influences from the interviewer. By generalizing the directions, the participant was forced to gather context about the situation from the UI.

Only one participant was able to successfully add the field boundary and name to the map. Even though this participant did not follow the optimal steps to complete the task, he was able to recover from his mistakes to complete the task. The other three were able to add the field name, but were unable to draw a field boundary. These participants were instructed to use an existing field to complete the remaining tasks in the interview.

The severe usability violation discovered was related to drawing the field boundary. After the participants added the field name, it was not clear that the next step was to touch the map at the corners of the field. Often the participant would touch the middle of the field. This would drop a pin in the middle of the field where they touched, but they did not continue to drop pins around the field. Often, they would drag their finger around the field which led to frustration because the map would pan with the dragging finger. Some participants would attempt to change the acre calculation manually. This violation is caused by lack of context and the need for minimalist design UI improvements.

Often, when participants began to feel lost and frustrated, their eyes would scan the screen for other context. If they didn't find any contextual help they started to touch seemingly random icons. This caused them to become so lost in the interface that it was nearly impossible for them to recover and complete the task. The results of the usability study should help developers anticipate where users will diverge from the optimal process and remove the distractions that lead to these errors.

The best solution would likely involve both removing distractions and adding context.

Overall, the participants were able to complete all tasks with the exception of the field boundary drawing for three participants. The limited data entry was streamlined with the use of drop down lists, a popup calendar, and check boxes.

### 6.3.3 OpenATK Planting App

The Planting App suffered from the same usability violation as the Tillage App due to the consistent UI between the field operation recordkeeping apps. However, it should be

noted that one more participant was able to figure out how to draw a field boundary while using the Planting App. The UI for drawing a field boundary did not change between the Tillage and Planting Apps, and no additional instructions were given to complete the task. The same solutions from the Tillage App should be applied to the Planting App to eliminate the usability violations.

Another project goal was realized when the participants were asked to make a record for a planting operation. It was a goal of the project to allow the farmer to take notes as he/she normally would rather than force the farm notes to conform to the recordkeeping software. In addition to the operator's name, date and operation status, the record contained notes about planting population, seed, refuge, and start fertilizer. Again, participants were instructed to use an existing field to complete the remaining tasks if they were not able to draw the new field boundary. Each participant was able to take notes a different way in the free form text entry boxes.

#### 6.3.4 OpenATK Field Notebook App

Overall, the users experienced fewest violations with the Field Notebook App compared to the Field Work and Planting Apps. An additional participant was able to draw a field boundary when using the Field Notebook App which is likely due to the participant gaining experience with the common UI.

Again, participants were instructed to make two notes: one about a wet spot and one about three spots in the field where they found pests. The four participants each made the notes slightly different ranging from only typed notes to a combination of typed notes and objects on the map. For the note about the pests, one participant only typed

a comment describing the location, one participant used a comment and location pins, one participant used a comment and three polygons, and one participant used a comment and a polyline connecting the three spots. The benefit of the free-form text entry is that it allows each participant to take in a way that makes sense to them.

#### 6.4 Summary

The OpenATK suite of apps was designed for three hypothetical user groups: Farm Owner Fred, Manager Mike, and Farm Hand Hank. These user groups were validated through the participants' responses and reactions throughout the usability testing interviews. The two participants representing the user Hank were the two youngest participants. They experienced the least amount of frustration and were able to complete a larger percentage of the tasks when using the four apps. However, they both mentioned the choice to implement this technology on their farm was not solely their decision. One participant also indicated a potential hurdle to implementation was the technical ability of the people in management positions. The user representing Mike experienced some frustration using the apps but his experience improved with continued use. The user representing Fred experienced the most difficulty using the apps and reacted negatively to the idea of using the mobile apps approach on his farm. While only one participant was able to successfully add a field boundary when first asked, three of the four participants were able to complete the task by the third attempt at completing the task. Each time they were not given any additional instructions, but they were given a fresh start. This suggests that the drawing functionality is learnable given a fresh start, and that the participants were simply too

lost to recover from their previous attempts. Once a participant learned how to complete a task, he successfully completed the task each subsequent attempt. This result suggests that the OpenATK approach where UI components are consistent across the suite of apps is appropriate because the success rate improved with increased exposure. This confirms that the past experience of the user is very important, and that developers of new apps need to understand the skills of their potential users.

## CHAPTER 7. CONCLUSIONS AND RECOMMENDATIONS

### 7.1 Conclusions

The FMIS discussed in this work was designed in accordance with proven user-centered design principles. This approach resulted in the creation of the OpenAgToolkit (OpenATK), and a suite of task-specific, collaborative Android apps. The OpenATK system architecture enabled apps to share data between apps on a device with shared local databases, and across devices on the farm using the cloud storage service Trello. The five Android apps were developed in the proposed architecture Rock App, Tillage App, Trello Sync App, Field Notebook App and Planting App. The first three listed are available for free on the Google Play store. Other apps such as the Anhydrous App and Spraying App were discussed with respect to their role in the OpenATK FMIS. The OpenATK approach is technically viable with current, consumer-grade technologies including free cloud storage, Wi-Fi and task-specific, collaborative Android apps running on tablet devices. The Tillage and Trello Sync Apps were used to generate artificial records for one year on a 404 ha (1,000 acre) farm to evaluate data storage needs. The total amount of data generated for the six field operations on the thirteen fields was 260 kilobytes.



The Rock, Tillage, Planting and Field Notebook Apps were evaluated for interface usability. The heuristic evaluation method was an appropriate evaluation method for the goals of this project as it enabled the observer to easily identify two critical interface usability problems: the long-hold method to move rock marker icons on the map, and drawing field boundaries. In this work, interviews with individual participants were used to evaluate usability. The interview participants lacked the motivation to figure it out because they were not out in the field trying to accomplish a specific task. Also, they did not have a vested interest because they did not choose to use the apps. This suggests that the personal interview method is not an ideal usability testing procedure.

## 7.2 Recommendations

### 7.2.1 Usability Improvements

Figure 39 shows one method that could be implemented to replace the long-hold for dragging objects on the map. When an object is selected, the move icon would appear next to the object to indicate that the object can be moved by dragging it. This new method should alleviate the issues with moving rock marker icons and field boundary markers. It should be implemented across the entire suite of apps any time a map object can be moved for consistency.

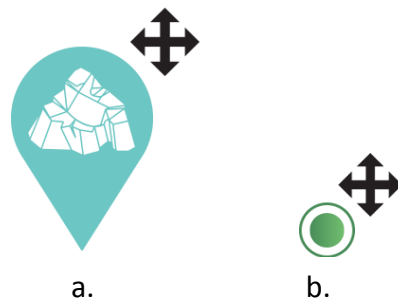

Figure 39: (a.) The current rock marker icon shown with an improved move icon. (b.) The current field boundary marker shown with an improved move icon.

The heuristic evaluation revealed a usability problem when the participants lost focus on the task at hand. Often, this occurred when interview participants became distracted while attempting to draw a field boundary. A solution to the minimalist UI design violation would remove any distracting UI components. An example of this design improvement would be removing all action icons except for those associated with drawing field boundaries. This includes hiding the display of area calculation until after the user has placed at least three boundary marker icons.

A simple solution to add context would be improving the “Add New Field” icon. The current icon is a “+” icon on the action bar. The user knows he/she is adding something, but a better icon would be similar to the one shown on the far left along with other action icons in Figure 40.



Figure 40: The action bar shown with the new “add field” icon (shown on the far left)

Another solution would be using a consistent menu for drawing on maps which would be used across the OpenATK apps. This could be easily accomplished by developing a library, and implementing it when the functionality for drawing on the map is needed. For the situation of drawing field boundary, only the polygon drawing functionality would be available to the user.

A possible solution to provide assistance would be to detect the first time a user attempts to add a field, and show some concise instructions for drawing a field boundary. This feature should be available through a help menu at any time, but it should only be shown for the first time a user is drawing a field boundary. Subsequent attempts should not require any assistance, and would likely result in slowing down an experienced user.

Based on internal testing, the current method of adding field boundaries to the apps is rather slow and tedious for oddly shaped fields when the user attempts to accurately draw the field. While the field boundaries could be added over time, many farms already have their field boundaries in other software. The OpenATK FMIS lacks the functionality to import these field boundaries, often in the shapefile format, into the apps or cards on Trello. This is a current research focus because it allows farmers to get started using the OpenATK FMIS more easily.

Based on feedback from users, the OpenATK Tillage App should be renamed to the OpenATK Field Work App. This recommended change emphasizes the importance of using terminology familiar to the farmers.

### 7.2.2 Future Apps

Farmers are looking for a complete FMIS for their specific needs, but they are not willing to learn how to use a different piece of software for each need. To this point, the current list of OpenATK apps does not provide a sufficient collection of software to fulfill the requirements from farmers. The OpenATK collection needs to expand to include apps to:

- Record information for every field operation
  - Harvest App
  - Manure Spreading App
  - Nitrogen Application Calculator
- Manage equipment maintenance
- Manage human resources
- Check the status of the crops throughout the growing season

Many farmers are comfortable with using office computers to get a “dashboard” view of everything happening on the farm or to complete more complex tasks similar to verifying management decisions. An OpenATK dashboard webpage would be the ideal solution for these tasks because it would be accessible through a web browser on any internet-connected device such as the office computer. The office computers benefit from the larger screens and more precise input devices, and many farmers already use office computers to manage farm information.

### 7.2.3 Future Versions

Future versions of the OpenATK Apps should automate data collection tasks by using intelligent algorithms and interfacing externally available data sources to infer context about the situation. This should simplify the work load on the operators and increase the value for the farm management.

### 7.2.4 Future Research Opportunities

The usability testing in this work only considered the individual OpenATK apps, and not the FMIS as a whole. Testing the individual UIs is not a sufficient test to determine the usability of the proposed system. The investigation of how a farm would use the system to keep records for various field operations throughout a growing season should be the focus for future research. The heuristic evaluation method should be appropriate for this evaluation as well.

This work relied on personal interviews with representative users to evaluate the usability of the apps which proved to not be ideal. Future usability testing would benefit from these users being in the field with a real incentive to complete the tasks. An ideal usability study would involve a farm implementing the necessary components and requiring the equipment operators to use the OpenATK Planting App to keep planting records. This would provide the most realistic results because the operators have incentive to learn how the app works and they would start from a blank map.

The principal goal of the OpenATK platform is to help farmers make better management decisions. The technologies selected for implementation aim to help farmers keep more accurate and complete records and to make that information available whenever, and

where ever it is needed. The OpenATK apps provide a flexible and reasonably complete FMIS solution that farms expect and need; however, to maximize their utility, the ability to observe and summarize the collected data in a format conducive to improving management decisions is needed. If farmers can “view” this data, aggregated as they wish and from different perspectives (field, worker, soil type, field operations, etc.), they will have the ability to mine data for improved decision making. Then, a key question to answer will be: “Does the OpenATK approach improve decision making?”

## REFERENCES

## REFERENCES

- Ag Leader. *SMS Software*. 2013. Available at: <http://www.agleader.com/products/sms-software/>. Accessed October 2013.
- AgIntegrated. *Onsite fueled by AgIntegrated*. 2012. Available at: <https://www.onsiteag.com/>. Accessed October 2013.
- AgRenaissance Software LLC. *FieldX Journal*. 2013 a. Available at: <http://www.fieldx.com/fieldx/fieldx-journal/>. Accessed November 2013.
- AgRenaissance Software LLC. *FieldX Office*. 2013 b. Available at: <http://www.fieldx.com/fieldx/fieldx-office/>. Accessed November 2013.
- AgriSight, Inc. *Mobile Farm Management Apps*. 2014. Available at: <http://farmlogs.com/farm-management-features/mobile-farming-apps>. Accessed January 2014.
- AgWorks, LLC. *Home*. 2013. Available at: <http://agworks.net/>. Accessed December 2013.
- Apple, Inc. *About iOS App Programming*. 2014 a. Available at: <https://developer.apple.com/library/ios/documentation/iPhone/Conceptual/iPhoneOSProgrammingGuide/Introduction/Introduction.html>. Accessed February 2014.
- Apple, Inc. *App States and Multitasking*. 2014 b. Available at: [https://developer.apple.com/library/ios/documentation/iPhone/Conceptual/iPhoneOSProgrammingGuide/ManagingYourApplicationsFlow/ManagingYourApplicationsFlow.html#//apple\\_ref/doc/uid/TP40007072-CH4-SW20](https://developer.apple.com/library/ios/documentation/iPhone/Conceptual/iPhoneOSProgrammingGuide/ManagingYourApplicationsFlow/ManagingYourApplicationsFlow.html#//apple_ref/doc/uid/TP40007072-CH4-SW20). Accessed February 2014.
- Apple, Inc. *Data Management in iOS*. 2014 c. Available at: <https://developer.apple.com/technologies/ios/data-management.html>. Accessed February 2014.
- Apple, Inc. *iCloud*. 2014 d. Available at: <http://www.apple.com/icloud/>. Accessed November 2013.



- Apple, Inc. iCloud Features. 2014 e. Available at: <http://www.apple.com/icloud/features>. Accessed November 2013.
- AppleInsider. Apple pegs iOS 7 distribution at 74%, iOS 6 at 22%. December 5, 2013. Available at: <http://appleinsider.com/articles/13/12/05/apple-pegs-ios-7-distribution-at-74-ios-6-at-22>. Accessed February 2014.
- Association for Technologies and Structures in Agriculture (KTBL). 2012. Available at: <http://www.agroxml.de/>. Accessed January 2014.
- Atlassian. Bitbucket. 2014. Available at: <https://bitbucket.org/>. Accessed February 2014.
- Ault, A., J. Krogmeier, and D. Buckmaster. 2013. Mobile, Cloud-Based Farm Management: A Case Study with Trello on My Farm. ASABE Paper No. 1593538. St. Joseph, Mich.: ASABE.
- Balmos, A.D., A.W. Layton, A. Ault, J.V. Krogmeier, and D.B. Buckmaster. 2013. Investigation of Bluetooth Communications for Low-Power Embedded Sensor Networks in Agriculture. ASABE Paper No. 131620559. St. Joseph, Mich.: ASABE.
- Balsamiq Mockups. 2013. Available at: <http://www.balsamiq.com/products/mockups>. Accessed September 2012.
- Bleicher, A. Farming by the Numbers. IEEE Spectrum. 30 May 2013. Available at: [http://spectrum.ieee.org/computing/it/farming-by-the-numbers/?utm\\_source=computerwise&utm\\_medium=email&utm\\_campaign=061213](http://spectrum.ieee.org/computing/it/farming-by-the-numbers/?utm_source=computerwise&utm_medium=email&utm_campaign=061213). Accessed 10 June 2013.
- Bluetooth SIG, Inc. Fast Facts. 2013. Available at: <http://www.bluetooth.com/Pages/Fast-Facts.aspx>. Accessed January 2014.
- Case IH. Case IH Advanced Farming Systems Overview. 2007. Available at: [http://caseihafs.com/uploads/documents/CIH8160701\\_AFS\\_Brochure.pdf](http://caseihafs.com/uploads/documents/CIH8160701_AFS_Brochure.pdf). Accessed October 2013.
- Chad. FSA Farm Field Borders (CLU). July 26, 2013. Available at: <http://support.agridatainc.com/FSAFarmFieldBordersCLU.ashx>. Accessed December 2013.
- Crop Ventures, Inc. 2014. Available at: <http://www.canplug.com/>. Accessed January 2014.
- CropLife. Slingshot API Connects Raven To OnSite App. March 15, 2012. Available at: <http://www.croplife.com/article/26379/slingshot-api-connects-raven-to-onsite-app>. Accessed October 2013.

- Deere & Co. Apex Farm Management Software. 2013 a. Available at: [http://www.deere.com/wps/dcom/en\\_US/products/equipment/ag\\_management\\_solutions/information\\_management/apex/apex.page](http://www.deere.com/wps/dcom/en_US/products/equipment/ag_management_solutions/information_management/apex/apex.page). Accessed October 2013.
- Deere & Co. John Deere Implement Detection. 2013 b. Available at: [http://www.deere.com/wps/dcom/en\\_US/products/equipment/ag\\_management\\_solutions/field\\_and\\_crop\\_solutions/implement\\_detection/implement\\_detection.page](http://www.deere.com/wps/dcom/en_US/products/equipment/ag_management_solutions/field_and_crop_solutions/implement_detection/implement_detection.page). Accessed November 2013.
- Deere & Co. JDLink. 2014 a. Available at: [http://www.deere.com/wps/dcom/en\\_US/products/equipment/ag\\_management\\_solutions/information\\_management/jdlink/jdlink.page#viewTabs](http://www.deere.com/wps/dcom/en_US/products/equipment/ag_management_solutions/information_management/jdlink/jdlink.page#viewTabs). Accessed January 2014.
- Deere & Co. *John Deere Mobile Farm Manager*. 2014 b. Available at: [http://www.deere.com/wps/dcom/en\\_US/products/equipment/ag\\_management\\_solutions/information\\_management/john\\_deere\\_mobile\\_farm\\_manager/john\\_deere\\_mobile\\_farm\\_manager.page](http://www.deere.com/wps/dcom/en_US/products/equipment/ag_management_solutions/information_management/john_deere_mobile_farm_manager/john_deere_mobile_farm_manager.page). Accessed January 2014.
- Diekmann, F., and M.T. Batte. *2010 Ohio Farming Practices Survey: Adoption and Use of Precision Farming Technology in Ohio*. The Ohio State University Report Series: AEDE-RP-0129-10, 2010.
- Dropbox. *Datastore API*. 2013 a. Available at: <https://www.dropbox.com/developers/datastore>. Accessed November 2013.
- Dropbox. *Dropbox*. 2013 b. Available at: <https://www.dropbox.com/>. Accessed November 2013.
- Fall Creek Software. *Trello*. 2013. Available at: <https://trello.com/>. Accessed August 2012.
- Fingas, J. *Android tops 81 percent of smartphone market share in Q3*. October 31, 2013. Available at: <http://www.engadget.com/2013/10/31/strategy-analytics-q3-2013-phone-share/>. Accessed February 2014.
- Fountas, S., S. Blackmore, D. Ess, S. Hawkins, G. Blumhoff, J. Lowenberg-Deboer, C.G. Sorensen. Farmer Experience with Precision Agriculture in Denmark and the U.S. Eastern Corn Belt. *Precision Agriculture*, 2005: 6(2):121-141.
- Fulton, J., A. Brook, and S. Virk. *Data Management at the Farm Level: 2013 Update*. Alabama Cooperative Extension System, 2013.
- GitHub, Inc. *GitHub*. 2014. Available at: <https://github.com/>. Accessed February 2014.

- Google. *About*. 2014 a. Available at: <http://www.google.com/drive/about.html>. Accessed November 2013.
- Google. *Action Bar*. 2014 b. Available at: <http://developer.android.com/guide/topics/ui/actionbar.html>. Accessed January 2014.
- Google. *Content Providers*. 2014 c. Available at: <http://developer.android.com/guide/topics/providers/content-providers.html>. Accessed February 2014.
- Google. *Dashboard*. 2014 d. Available at: [http://developer.android.com/about/dashboards/index.html?utm\\_content=buffer7a7fe&utm\\_medium=social&utm\\_source=twitter.com&utm\\_campaign=buffer](http://developer.android.com/about/dashboards/index.html?utm_content=buffer7a7fe&utm_medium=social&utm_source=twitter.com&utm_campaign=buffer). Accessed February 2014.
- Google. *Develop*. 2014 e. Available at: <http://developer.android.com/develop/index.html>. Accessed February 2014.
- Google. *Get the Android SDK*. 2014 f. Available at: <http://developer.android.com/sdk/index.html>. Accessed January 2014.
- Google. *Google Drive SDK*. 2014 g. Available at: <https://developers.google.com/drive/about-sdk>. Accessed November 2013.
- Google. *Google Maps Android API v2*. 2014 h. Available at: <https://developers.google.com/maps/documentation/android/>. Accessed January 2014.
- Google. *Location APIs*. 2014 i. Available at: <https://developer.android.com/google/play-services/location.html>. Accessed January 2014.
- Google. *Storage*. 2014 j. Available at: <http://www.google.com/drive/storage.html>. Accessed November 2013.
- Google. *Storage Options*. 2014 k. Available at: <http://developer.android.com/guide/topics/data/data-storage.html>. Accessed February 2014.
- Google. *Store*. 2014 l. Available at: <https://play.google.com/store>. Accessed February 2014.
- Google. *Transferring Data Using Sync Adapters*. 2014 m. Available at: <http://developer.android.com/training/sync-adapters/index.html>. Accessed February 2014.

- Griffin, T.W., J. Lowenberg-DeBoer, D.M. Lamber, J. Peone, T. Payne, and S.G. Daberkow. *Adoption, Profitability, and Making Better Use of Precision Farming Data*. Staff Paper #04-06 Dept. Of Agricultural Economics, Purdue University, 2004.
- Haapala, H.E.S., L. Pesonen, and P. Nurkka. Usability as a Challenge in Precision Agriculture - Case Study: an ISOBUS VT. *Agricultural Engineering International: the CIGR Ejournal. Manuscript MES 05 001. Vol. VIII*, March 2006.
- Han, W., Z. Yang, L. Di, A.L. Yagci, and S. Han. Making Cropland Data Layer Data Accessible and Actionable in GIS Education. *Journal of Geography*, 2014.
- Heap, T. An Agile Functional Specification. *Bridging the Gap*. 29 June 2011. Available at: <http://www.bridging-the-gap.com/an-agile-functional-specification/>. Accessed June 2013.
- Huting, Kathy. "Fire Up That Smartphone." *Farm Industry News*, January 2014: 8-10.
- ISOBlue. 2013. Available at: <http://isoblue.org/>.
- Krug, Steve. 2006. *Don't Make Me Think: A Common Sense Approach to Web Usability*. Second Edition. Berkeley, California: New Riders Publishing.
- Microsoft. *Compare SkyDrive*. 2014 a. Available at: <http://windows.microsoft.com/en-us/skydrive/compare>. Accessed January 2014).
- Microsoft. *Guidlines for Accessing SkyDrive from an App*. 2014 b. Available at: <http://msdn.microsoft.com/en-us/library/windows/apps/dn263258.aspx>. Accessed January 2014.
- Miser, B. *Connecting to the Internet via a Cellular Data Network*. 5 January 2012. Available at: <http://www.quepublishing.com/articles/article.aspx?p=1805465&seqNum=2>. Accessed January 2014.
- Monsanto. *Integrated Farming Systems*. 2013. Available at: <http://www.monsanto.com/products/Pages/integrated-farming-systems.aspx>. Accessed October 2013.
- Murakami, E., A.M. Saraiva, L.C.M., Jr. Ribeiro, C.E. Cugnasca, A.R. Hirakawa, and P.L.P. Correa. An Infrastructure For The Development of Distributed Service-Oriented Information Systems for Precision Agriculture. *Computers and Electronics in Agriculture*, 2007: 37-48.

- National Oceanic and Atmospheric Administration (NOAA) Coastal Services Center. *Lidar 101: An Introduction to Lidar Technology, Data, and Applications*. Charleston, SC: NOAA Coastal Services Center, 2012.
- National Weather Service. *Advanced Hydrologic Prediction Service*. 06 February 2013. Available at: <http://water.weather.gov/precip/download.php>. Accessed June 2013.
- New Holland. *PLM Books*. 2013 a. Available at: <http://agriculture.newholland.com/us/en/PLM/data/software/Pages/Books.aspx> (accessed November 2013).
- New Holland. *PLM Mapping*. 2013 b. Available at: <http://agriculture.newholland.com/us/en/PLM/data/software/Pages/Mapping.aspx>. Accessed November 2013.
- New Holland. *PLM Viewer*. 2013 c. Available at: <http://agriculture.newholland.com/us/en/PLM/data/software/Pages/Viewer.aspx>. Accessed November 2013.
- New Holland. *PLM Water Control*. 2013 d. Available at: <http://agriculture.newholland.com/us/en/PLM/data/software/Pages/Water.aspx>. Accessed November 2013.
- Nielsen, J. *Usability Metrics*. 21 January 2001. Available at: <http://www.nngroup.com/articles/usability-metrics/>. Accessed January 2013.
- Nielsen, J. *Usability 101: Introduction to Usability*. 4 January 2012. Available at: <http://www.nngroup.com/articles/usability-101-introduction-to-usability/>. Accessed October 2013.
- Noel, S. May 2014. *Watershed Delineation in the Field: A New Approach for Mobile Applications Using LiDAR Elevation Data*. *MS Thesis*. West Lafayette, Indiana: Purdue University, Agricultural & Biological Engineering Dept.
- Norros, L., L. Pesonen, P. Suomi, and C. Sorensen. Implementing systems usability evaluation in the design process of active farm management information system. *EFITA conference '09*. Wageningen, The Netherlands: Wageningen Academic Publishers, 2009. 243-252.
- Nurkka, P., L. Norros, and L. Pesonen. Improving Usability and User Acceptance of Information Systems in Farming. *EFITA/WCCA Joint Congress in IT in Agriculture*. Glasgow, 2007.

- OAuth. 2014. Available at: [oauth.net](http://oauth.net). Accessed January 2014.
- Open Ag Toolkit*. 2013. Available at: <http://openagtoolkit.com/>.
- OpenTopography*. 2013. Available at: <http://www.opentopography.org/>.
- Perlman, Seth. Rising costs lead farmers to go high tech. *USA TODAY*. May 25, 2008. [http://usatoday30.usatoday.com/tech/news/2008-05-25-farmers-high-tech\\_n.htm](http://usatoday30.usatoday.com/tech/news/2008-05-25-farmers-high-tech_n.htm). Accessed June 2013.
- Pesonen, L., H. Koskinen, and A. Rydberg. Info XT - User-centric mobile information management in automated plant production. *Nordic Innovation Center report series*, 2008.
- Pioneer. *Pioneer Field360 Services*. 2013. Available at: <https://www.pioneer.com/home/site/us/programs-services/pioneer-field360/>. Accessed December 2013.
- Potter, Ben. Unlock Your Farm Data. *Ag Web*. February 15, 2013. Available at: [http://www.agweb.com/article/unlock\\_your\\_farm\\_data/](http://www.agweb.com/article/unlock_your_farm_data/).
- Precision Planting. *FieldView*. 2013 a. Available at: <http://precisionplanting.com/Products/FieldView/Default.aspx>. Accessed January 2014.
- Precision Planting. *FieldView Plus*. November 2013 b. Available at: <https://fieldviewplus.precisionplanting.com/>. Accessed January 2014.
- Raven Industries. *Slingshot Online*. 2013 a. Available at: <http://ravenslingshot.com/products/slingshot-online/>. Accessed October 2013.
- Raven Industries. *Slingshot API*. 2013 b. Available at: <http://ravenslingshot.com/products/slingshot-api/>. Accessed October 2013.
- Raven Industries. *Slingshot Field Hub*. 2013 c. Available at: <http://ravenslingshot.com/products/slingshot-field-hub/>. Accessed October 2013.
- Sindir, K. 2006. Management and Decision Support Systems. *CIGR Handbook of Agricultural Engineering Vol6*.
- Snyder, D. 18 April 2013. *Mobile Devices, the Cloud, and their Effect on Next Generation Measurement Systems*.

- Sorensen, C.G., S. Fountas, E. Nash, L. Pesonen, D. Bochtis, S.M. Pedersen, B. Basso, S.B. Blackmore. 2010. Conceptual Model of a Future Farm Management Information System. *Computers and Electronics in Agriculture*: 37-47.
- Sorensen, C.G., L. Pesonen, D.D. Bochtis, S.G. Vougioukas, and P. Suomi. 2011. Functional Requirements for a Future Farm Management Information System. *Computers and Electronics in Agriculture*: 266-276.
- Spolsky, J. Painless Functional Specifications - Part 2: What's a Spec? *Joel on Software*. 3 October 2000. Available at: <http://www.joelonsoftware.com/articles/fog0000000035.html>. Accessed September 2012).
- SST Software. *SST Summit*. 2013. Available at: <http://www.sstsoftware.com/products-services/sst-summit/>. Accessed December 2013.
- Steimel, Dick. On the cutting edge to feed a hungry world. *Iowa Farm Bureau Farm Fresh Blog*. 15, July 2011. Available at: <http://iowafarmbureau.wordpress.com/2011/07/15/on-the-cutting-edge-to-feed-a-hungry-world/>. Accessed June 2013.
- Steinberger, G., M. Rothmund, and H. Auernhammer. Mobile Farm Equipment As A Data Source In An Agricultural Service Architecture. *Computers and Electronics in Agriculture*, 2009: 238-246.
- Stringybark Software Pyt. Ltd. *Home*. 2014. Available at: <http://stringybarksoftware.com/>. Accessed January 2014.
- TN.gov. Hurry! Early Registration for Farmland Legacy Conference Ends Nov. 1. *TN.GOV Newsroom & Media Center*. 27 October 2010. Available at: <http://news.tn.gov/node/6252>. Accessed June 2013.
- Trimble Navigation Limited. *Apps*. 2013. Available at: <http://www.connectedfarm.com/apps.html>. Accessed January 2014.
- Trimble Navigation Limited. *ConnectedFarm Dashboard*. 2009 a. Available at: <http://www.farmworks.com/products/connectedfarm>. Accessed January 2014.
- Trimble Navigation Limited. *Office Software*. 2009 b. Available at: <http://www.farmworks.com/products/officesoftware>. Accessed January 2014.
- United Soils, Inc. *I.F.A.R.M.* 2013. Available at: <http://unitedsoilsinc.com/iFARM.html>. Accessed November 2013.

- USDA Farm Service Agency. *Common Land Unit*. 03 December 2013. Available at: <http://www.fsa.usda.gov/FSA/apfoapp?area=home&subject=prod&topic=clu>. Accessed December 2013.
- USDA National Agricultural Statistics Services. *CropScape - Cropland Data Layer*. 2014. Available at: <http://nassgeodata.gmu.edu/CropScape/>. Accessed January 2014.
- USDA Natural Resources Conservation Service. 2013. *Web Soil Survey*. Available at: <http://websoilsurvey.nrcs.usda.gov/app/WebSoilSurvey.aspx>. Accessed June 2013.
- Welte, J., A. Ault, C. Bowman, S. Ellis, D. Buckmaster, D. Ess, J. Krogmeier. 2013 a. An Approach to Farm Management Information Systems Using Task-Specific, Collaborative Mobile Apps and Cloud Storage Services. ASABE Paper No. 1579954. St. Joseph, Mich.: ASABE.
- Welte, J., A. Ault, C. Bowman, A. Layton, S. Noel, J. Krogmeier, D. Buckmaster. 2013 b. Autogenic Mobile Computing Technologies in Agriculture: Applications and Sensor Networking for Smart Phones and Tablets. Paper No: C0340. Paris, France: EFITA
- Western Digital. *My Cloud*. 2014. Available at: [http://store.westerndigital.com/store/wdus/en\\_US/pd/ThemeID.21986300/productID.292209200/parid.56796900/catid.56857800/categoryID.66881000](http://store.westerndigital.com/store/wdus/en_US/pd/ThemeID.21986300/productID.292209200/parid.56796900/catid.56857800/categoryID.66881000). Accessed January 2014.
- Whipker, L.D., and J.T. Akridge. 2009 Precision Agricultural Services Dealership Survey Results. no. Working Paper#09-16. Purdue University Center for Food and Agricultural Business, 2009.
- Wi-Fi Alliance. 2014. Available at: <http://www.wi-fi.org/>. Accessed January 2014.
- ZedX, Inc. *AgFleet About*. 2014 a. Available at: <https://www.agfleet.com/about.php>. Accessed January 2014.
- ZedX, Inc. *Product Info*. 2014 b. Available at: [https://www.agfleet.com/prod\\_info.php](https://www.agfleet.com/prod_info.php). Accessed January 2014.



## APPENDICES

## **Functional Specifications for the OpenATK Tillage App**

### **1.0 OVERVIEW/MISSION**

The purpose of the Precision Agricultural Tillage App is to provide a simple means of automatically recording data pertaining to tillage operations and displaying feedback to the users. The data collected will be used for easy recording of tillage operations for both short- and long-term planning.

### **2.0 HYPOTHETICAL USER GROUPS**

#### **2.1 Farm Owner Fred**

Fred is the family farm owner and has lived on the family farm since childhood. Fred has been the leader of the farm for 10 years when he inherited the farm from his father who farmed the same 250 acres till the day of his passing. Fred grew up in a family with three other siblings, all girls. As the oldest sibling and the only boy, he elected to forego higher education to return to the farm and help his father provide for the family. Fred is now 68 years of age; husband of 45 years; and father of five children. After the passing of his father he aggressively acquired more land as it became available within a reasonable distance from the original farm. He has reluctantly adopted new farming practices and management styles when the pressures of the larger farm forced him to adapt. With the last acquisition of land, the farm has surpassed the 2000 acre mark. As

the need for larger equipment increased, he has purchased several used tractors and implements and leases a new combine from a local dealer.

Fred spends approximately 50-60% of his time working on the farm, and the rest of the time in the farm office where he oversees farm operations, seasonal planning, and purchasing. His lifetime of experiences and countless lessons from his father have taught him that his intuition is almost always correct. He prefers the tried-and-true, proven methods of farming and management. He is skeptical of the idea of integrating technology into his farming operation because past experiences with new technology have lead him to believe the time commitment and costs are too large to warrant his continued interest. He lacks the technical and mechanical skills to use the technology effectively, and until a couple years ago he was unaware of precision farming technology.

Recently he attended a trade show where new precision farming technology was one of the featured innovations. After watching the demonstrations and talking with some long time farming friends, they agree the opportunity is there to reduce input costs and positively aid the decision making process. However, without the formal training, many of them feel the large time commitment is too great for the risk of frustration. For them, it has to work the first time and every time after that or they will abandon it for the proven methods.

## **2.2 Farm Manager Michael**

Michael is the 40-year-old son of Fred. Although Michael was raised on the family farm, after high school, he left home for college and received a bachelor's degree in

mechanical engineering. During his time at college he found the love of his life and his dream job. Following graduation he moved to the suburbs of a city near the family farm where he settled down working for an engineering consulting company and started a family. After working in industry for six years, his grandfather's health began to decline and his father's role on the farm became more important. At the age of 28, he quit his job at the consulting firm, relocated the family near the farm, and took a job working for his father and grandfather with the intent to assume a middle management position.

Michael is currently the manager for human and equipment resources. In this role, which answers directly to his father, he oversees the allocation of workers and equipment to complete all farming operations. He spends roughly 80-90% of his time outside of the office and often assumes various roles to assist operations including but not limited to: equipment maintenance and operation, and seasonal planning. His education and industry experiences have taught him that a respected and successful manager must stay involved in all aspects of the operation. Michael enjoys every minute of his job and is committed to the future success of the family farm.

Michael's education training and industry experiences have proved the value of emerging technologies for data management. He understands most technologies are generalized for the largest market but with a little time and testing, they can be adapted to fit many useful situations. Unlike his father, he believes incorporating precision agriculture technologies are necessary to increase profit and make better informed decisions about short- and long-term planning. In his current position on the farm he is able to work directly with the other equipment operators who will be the primary users

of the technology to collect data. His father has taken the approach where he lets Michael test new technologies and he'll consider it more when Michael has done the legwork to get it started and can prove its worth. Fred does not care if it succeeds or fails as long as it does not cause too much hassle for him.

### **2.3 Farm Hand Hank**

Hank is a non-family employee on the farm. He has been a lifelong resident of the local farming community where he has lived for 27 years. After graduating high school, he passed on higher education because he did not feel it was a good fit for him. Prior to coming to work for Fred two years ago, he worked for a different local farmer for six years which unfortunately ended due to management issues. He was drawn to work for Fred and Michael because he values the family aspect of the management and their commitment to expansion and responsible farming.

Hank is a general equipment operator under the management of Michael. He spends 95-100% of his time in the field or on the road. His tasks vary with the seasonal operations to include tillage, grain hauling, and equipment maintenance.

Hank is the primary user of the tillage app because he is most likely to be the user who is collecting the tillage data from the field. His relaxed and casual attitude toward decision making can occasionally lead to neglecting proper data recording which causes tension between Hank and management. Often, Michael is able to make necessary adjustments or corrections to Hank's records before they make it to Fred's desk.

## **3.0 USER STORIES**

### **3.1 Hank uses the Tillage App to record a chisel operation for a new field**

One fall afternoon, Hank receives instructions to chisel plow Field 4 from Michael.

When Hank gets to the field he opens the Tillage App, taps “Tillage” (the default mode) and selects “Chisel” from the drop down navigation in the top left of the action bar. He sees the map view, but does not find the field boundary and operation plan for Field 4.

He taps the action bar icon to add a new field which opens the boundary drawing function on the map view. He selects the boundary points on the map, taps the check mark in the bottom left of the screen and sees the field outline and menu slide up on the screen. The app generates a field name and estimates the size based on boundary coordinates. The new field defaults to “Done” which he appropriately changes to “In Progress” and is given that day’s date. If this was Hank’s first time using the Tillage App he would have to manually input his name into the “Operator” entry field. This entry would be cached for future use. He can optionally add comments or a photo, or edit any information from the menu.

### **3.2 Hank uses the Tillage App to record a tillage operation for a field previously planned**

Hank receives a text message from Michael instructing him to chisel plow Field 4. He opens the Tillage App and sees the red boundary of Field 4 on the map view. After completing the planned chisel operation, Hank taps the polygon for Field 4 which brings up the menu from the bottom of the screen. He appropriately changes the status from “Planned” to “Done” which changes the polygon from red to green. He accepts the

changes by selecting the check mark icon in the bottom left of the menu or tapping anywhere on the map.

### **3.3 Fred and Michael use the Tillage App to plan spring tillage operations**

During a meeting in the fall, Fred and Michael open the Tillage App to plan fields for spring tillage. Michael taps the drop down navigation from the action bar and adds a new mode “Spring Planting Prep”. He sees a gray polygon any field previously used in the Tillage App or any field available from the Fields Manager App. For each field they would like prepared for spring planting, he selects and changes the status to “Planned” which changes the polygon from gray to red. Additionally, he can assign the operation to a particular employee by inputting an operator’s name.

### **3.4 Michael uses the Tillage App to plan the day’s operations**

Michael begins a late fall morning by opening the Tillage App to see how many fields remain to be chiseled. He taps the list icon in the action bar which displays the field information in an expandable, vertical list. He sees the summary information at the top of the screen which says 247 acres remain which have been planned for chiseling. He taps the single field, Field 5, in the “In Progress” list which flips the list item over to show more information, including the field’s location. To get a more clear picture of the location relative to other fields which need to be completed he taps the map icon on the Field 5 card. This displays the map view and zooms to Field 5. Using the appropriate “zoom out” motions, he finds three more fields near Field 5, and instructs Hank to finish Field 5 before beginning the three nearby fields.

## 4.0 ANTICIPATED ISSUES

- Cellular connection issues
- Incomplete or inconsistent data input from user
- GPS signal quality
- Sections of fields intentionally left untilled
- User forgetting to open the app before tillage begins
- User forgetting to press start/stop during the operation
- User forgets to changed cached information
- Multitasking users
- Phone call/text interruptions
- Multiple phones in same field/equipment
- Switch user in the middle of a task
- Field Boundaries and Farm Plan... both? one? neither?
- Drawing field boundary polygons
- Contour or Strip Farming styles
- Cross mobile OS platform compatibility

## 5.0 USER INTERFACE (UI) DESIGN

The figures below show the UI in both the map and list views. The UI mockups have been designed using the web-based software Balsamiq.

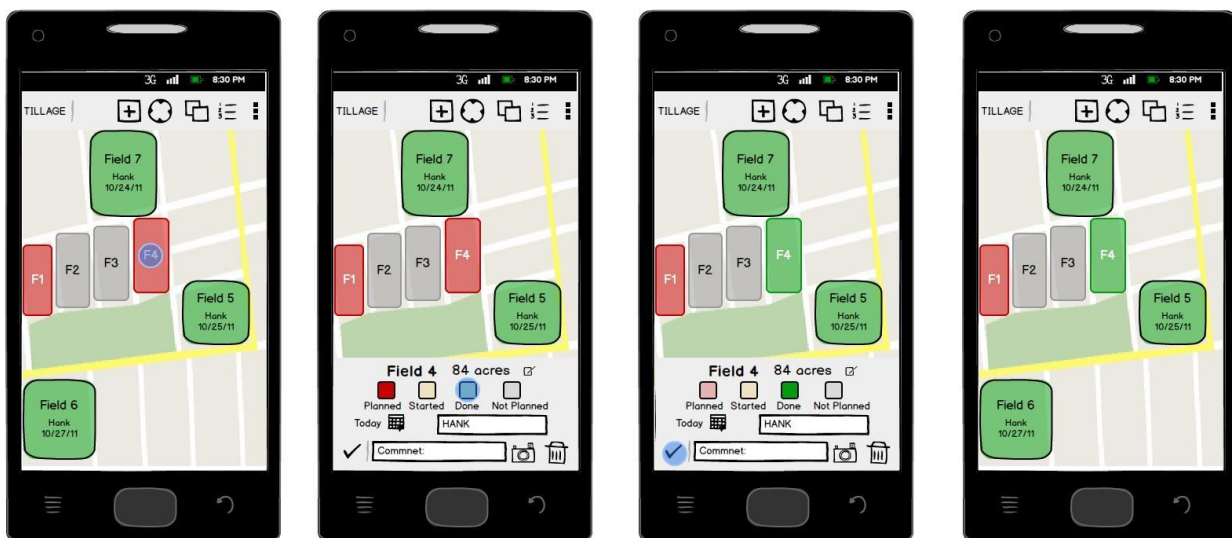





## 6.0 EXAMPLE FIRST TIME USE SITUATION

The figure below walks through how a user would begin to use the Tillage App, what we'll call the "First Time Use Situation". The user needs to immediately understand the UI and feel comfortable using the app. If the learning curve is too high or the user becomes frustrated, they are unlikely to open the app again to use it. For this reason, particular attention must be given to the user experience for the first time use situation. The map view and icons have been selected to give the first time user immediate comfort and control.

The user will open the Tillage App to find a map view similar to other internet mapping websites. The icons are placed on the Android action bar according to the Android development files. The user will find an icon to add a new field, an icon to move the map to their location, an icon to control map overlays, an icon to switch to the list view, and the default icon for action bar overflow.

The user will select the [+] to add a new field which will open the field drawing mode. In this mode the user can select polygon vertices to draw the field boundary. After accepting the polygon, the field boundary will appear on the map view and the menu bar will slide up from the bottom of the screen. The menu bar contains entry fields for the information associated with the tillage operation such as field name and size, operation status, date and operator name.

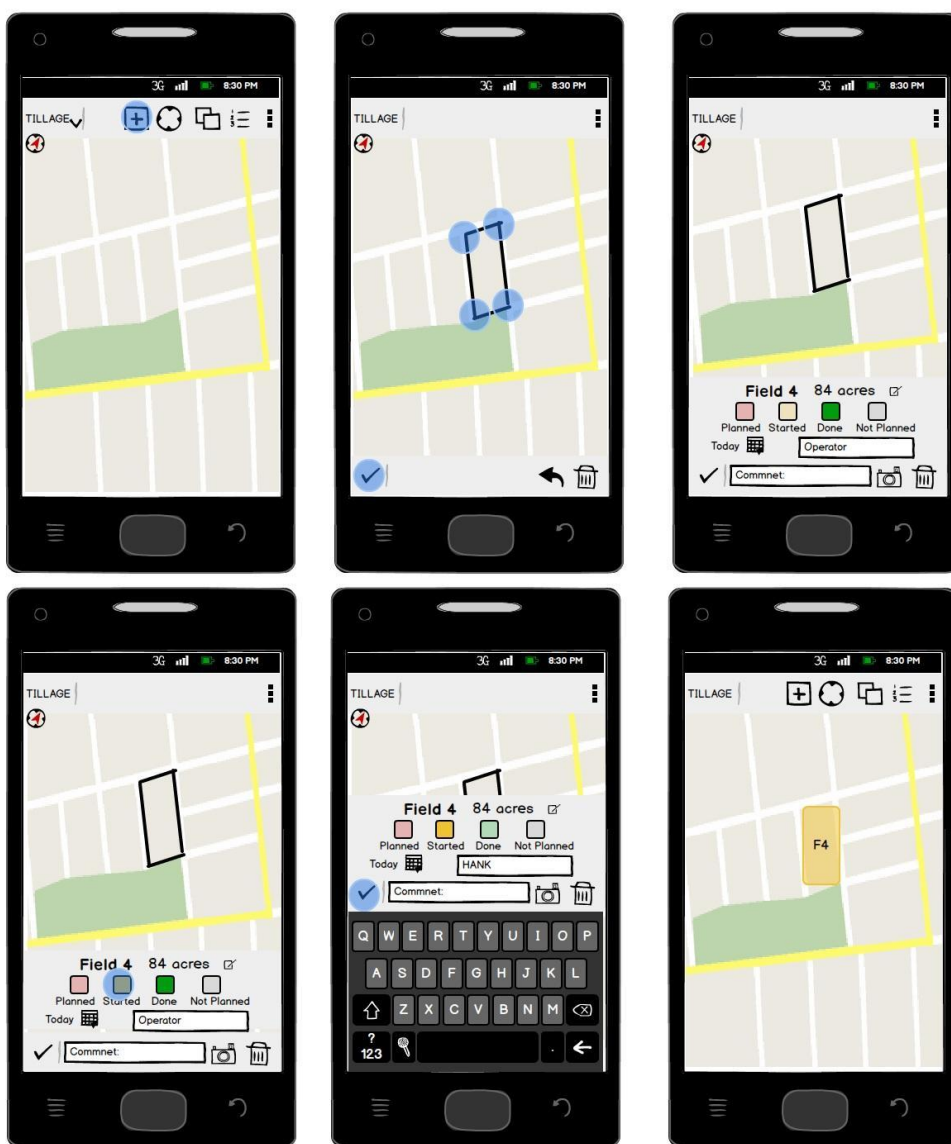

## 7.0 NON-GOALS AND FUTURE FEATURES

Upon completion of the Tillage App, the technology could be applied to planting operations, turf and golf course maintenance, and lawn care contractors. From research in mobile device applications, it is understood that several, specific function apps are more useful than a single app intended to do everything. There are many farming tasks which require the transmission of data to management and/or other workers. To maximize functionality of this app, it would need to generate data for other devices and apps, as well as be able to utilize data generated from other devices and apps. The app should work as part of a suite of agriculture specific apps, each designed to help complete a specific task. It will also need to be individually useful if the farm management decides to adopt this technology slowly.

Appendix B IRB Approved Recruitment Email to Potential ASM Student Participants

Hello:

We are performing a usability and utility study of Open Ag Toolkit apps, which are free and available on the Google Play store. Please note that your participation in this usability study is completely voluntary and you can withdraw at any time. Your decision to participate or decline will have no effect on your class standing or grade in any course. If you choose to participate in this study it will require no more than one hour of your time. If you participate, I will meet with you individually simply to observe your use and reaction to our apps. I will not collect any data that is identifiable to you. There is no compensation for participation.

If you are interested in participating, simply reply to this email and I will follow-up to arrange a 1-hour session.

Jonathan Welte  
Graduate Student in Agricultural and Biological Engineering  
Purdue University  
225 S. University Street, ABE 307  
West Lafayette, IN 47907  
812-598-7746  
jwelte@purdue.edu

Appendix C IRB Approved Recruitment Email to Potential PAC Employee Participants

Hello:

We are performing a usability and utility study of Open Ag Toolkit apps, which are free and available on the Google Play store. Please note that your participation in this usability study is completely voluntary and you can withdraw at any time. If you choose to participate in this study it will require no more than one hour of your time. If you participate, I will meet with you individually simply to observe your use and reaction to our apps. I will not collect any data that is identifiable to you. There is no compensation for participation.

If you are interested in participating, simply reply to this email note and we will follow-up to arrange a 1-hour session.

Jonathan Welte  
Graduate Student in Agricultural and Biological Engineering  
Purdue University  
225 S. University Street, ABE 307  
West Lafayette, IN 47907  
812-598-7746  
jwelte@purdue.edu

Appendix D IRB Approved Consent Form for ASM Student Participants

**What is the purpose of this study?**

Our research group has developed a collection of software for smartphones and tablets to improve the information collection and communication on farms. We believe our software is more usability and provides greater utility to its users than current farm management information systems. We need to get the reaction of the users by observing them using the software and collecting their comments.

**What will I do if I choose to be in this study?**

The personal interviews will take place with a single interviewer. I, J.T. Welte, as the interviewer, will be leading the session as well as observing you to determine the usability and utility of the software in a farm setting. Throughout the interview I will ask you to think aloud so that I can better understand what you are thinking. The entirety of the interview will be audio recorded so ensure the correctness of data collected. First, I will introduce the study to you. Following the introduction, you will be asked a series of questions. The answers to these questions will serve as a background for me and initiate a conversational style interview. This portion of the interview should last approximately 10 minutes. I will be collecting data such as:

- Your role on a farm
- Experience with mobile computing devices
- Use of phones or mobile computing devices in a farm setting
- Use of existing software applications(apps)

- Opinions towards cloud storage services
- Farm's method of record keeping
- Opinion of farm's method of record keeping

Next, you will be shown three or four apps running on a mobile electronic device. You will be asked a series of questions to see what you think the apps can do. You will be instructed to complete a series of specific tasks. I will observe where you succeed and where you get frustrated. However, it is important that I not show agreement or offer any assistance. Any help from me would contaminate the results. The observation period of the interview should last 10-20 minutes. I will be collecting data such as:

- Opinions toward the functionality of each app
- Opinions toward the utility of each app
- Time necessary to complete each task

This will be followed by some questions and an open discussion lasting 10-20 minutes. You will be asked a series of questions to help determine if the apps used have utility in a farm setting. You will be invited to speak openly about your thoughts which were not specifically asked.

**How long will I be in the study?**

This one time interview should last no longer than one hour. There may be future opportunities for your participation in another interview. However, you will be contacted by another individual from our research group if you are interested.

**What are the possible risks or discomforts?**

The standard for minimal risk is that which is found in everyday life. Breach of confidentiality is a risk associated with research. However, the research team has in place safeguards, as discussed in the confidentiality section of the consent form, to reduce the risk of breach of confidentiality. In the event Dr. Buckmaster serves an administrative or authoritative role over you, he will not have access to participation records until after final semester grades are posted to limit the potential of undue influence. Your decision to participate or decline will have no effect on your class standing or grades. All data and records will be maintained by Jonathan Welte until the time Dr. Buckmaster is no longer a potential advisor/instructor to you. The most likely risk would involve frustration stemming from an inability to operate the software as intended. However, this frustration should not be taken personal, and we have included a reminder in the interview introduction to reflect this. "We want to make it clear right away that we're testing the software, not you. You cannot do anything wrong here so there is no reason to worry about making mistakes."

**Are there any potential benefits?**

There are no direct benefits. You may gain some experience using these apps with the potential for instructions following the interview, time permitting.

If you feel you have been injured due to participation in this study, please contact Dr. Dennis Buckmaster (dbuckmas@purdue.edu 765-496-9512) or Jonathan Welte (jwelte@purdue.edu 812-598-7746). Purdue University will not provide medical treatment or financial compensation if you are injured or become ill as a result of



participating in this research project. This does not waive any of your legal rights nor release any claim you might have based on negligence.

The following disclosure(s) is(are) made to give you an opportunity to decide if this(these) relationship(s) will affect your willingness to participate in the research study.

**Will information about me and my participation be kept confidential?**

Audio recordings will be transcribed, and then destroyed within 30 days of completing the personal interview. Notes taken by the interviewer will not include identifiable information.

The apps will not ask for any personal information. User accounts will not be required to use any of the apps. The apps can synchronize to cloud storage services. This functionality is not being tested, and will be disabled. If for any reason some data is uploaded to cloud storage, it will be deleted along with all data store locally on the devices immediately following the interview.

You will be instructed to enter hypothetical data. If, for some reason you respond with any identifiable information, it will be de-identified before transcription. The only documentation of participation will be the signed consent forms, which will be virtually impossible to match to your responses.

The session transcriptions are the raw data which is very important to save, and will thus be stored indefinitely. The interview transcriptions, notes and consent forms will be stored in a locked desk drawer in Jonathan Welte's office until the end of the semester when they will be moved to a locked file cabinet in Dr. Buckmaster's office. Dr.

Buckmaster's access to the files will be restricted until final semester grades are posted to limit the potential of undue influence on the student participants.

The project's research records may be reviewed by Office for Human Research and by departments at Purdue University responsible for regulatory and research oversight.

**What are my rights if I take part in this study?**

Your participation in this study is voluntary. You may choose not to participate or, if you agree to participate, you can withdraw your participation at any time without penalty or loss of benefits to which you are otherwise entitled.

**Who can I contact if I have questions about the study?**

If you have questions, comments or concerns about this research project, you can talk to one of the researchers. Please contact Dr. Dennis Buckmaster (dbuckmas@purdue.edu 765-496-9512) or Jonathan Welte (jwelte@purdue.edu 812-598-7746).

If you have questions about your rights while taking part in the study or have concerns about the treatment of research participants, please call the Human Research Protection Program at (765) 494-5942, email (irb@purdue.edu) or write to:

Human Research Protection Program - Purdue University

Ernest C. Young Hall, Room 1032

155 S. Grant St.,

West Lafayette, IN 47907-2114

**Documentation of Informed Consent**

I have had the opportunity to read this consent form and have the research study explained. I have had the opportunity to ask questions about the research study, and my questions have been answered. I am prepared to participate in the research study described above. I will be offered a copy of this consent form after I sign it.

---

Participant's Signature

---

Date

---

Participant's Name

---

Researcher's Signature

---

Date

Appendix E IRB Approved Consent Form for PAC Employee Participants

**What is the purpose of this study?**

Our research group has developed a collection of software for smartphones and tablets to improve the information collection and communication on farms. We believe our software is more usability and provides greater utility to its users than current farm management information systems. We need to get the reaction of the users by observing them using the software and collecting their comments.

**What will I do if I choose to be in this study?**

The personal interviews will take place with a single interviewer. I, J.T. Welte, as the interviewer, will be leading the session as well as observing you to determine the usability and utility of the software in a farm setting. Throughout the interview I will ask you to think aloud so that I can better understand what you are thinking. The entirety of the interview will be audio recorded so ensure the correctness of data collected. First, I will introduce the study to you. Following the introduction, you will be asked a series of questions. The answers to these questions will serve as a background for me and initiate a conversational style interview. This portion of the interview should last approximately 10 minutes. I will be collecting data such as:

- Your role on a farm
- Experience with mobile computing devices
- Use of phones or mobile computing devices in a farm setting
- Use of existing software applications(apps)

- Opinions towards cloud storage services
- Farm's method of record keeping
- Opinion of farm's method of record keeping

Next, you will be shown three or four apps running on a mobile electronic device. You will be asked a series of questions to see what you think the apps can do. You will be instructed to complete a series of specific tasks. I will observe where you succeed and where you get frustrated. However, it is important that I not show agreement or offer any assistance. Any help from me would contaminate the results. The observation period of the interview should last 10-20 minutes. I will be collecting data such as:

- Opinions toward the functionality of each app
- Opinions toward the utility of each app
- Time necessary to complete each task

This will be followed by some questions and an open discussion lasting 10-20 minutes. You will be asked a series of questions to help determine if the apps used have utility in a farm setting. You will be invited to speak openly about your thoughts which were not specifically asked.

**How long will I be in the study?**

This one time interview should last no longer than one hour. There may be future opportunities for your participation in another interview. However, you will be contacted by another individual from our research group if you are interested.

**What are the possible risks or discomforts?**

The standard for minimal risk is that which is found in everyday life. Breach of confidentiality is a risk associated with research. However, the research team has in place safeguards, as discussed in the confidentiality section of the consent form, to reduce the risk of breach of confidentiality. The most likely risk would involve frustration stemming from an inability to operate the software as intended. However, this frustration should not be taken personal, and we have included a reminder in the interview introduction to reflect this. “We want to make it clear right away that we’re testing the software, not you. You cannot do anything wrong here so there is no reason to worry about making mistakes.”

**Are there any potential benefits?**

There are no direct benefits. You may gain some experience using these apps with the potential for instructions following the interview, time permitting.

If you feel you have been injured due to participation in this study, please contact Dr. Dennis Buckmaster (dbuckmas@purdue.edu 765-496-9512) or Jonathan Welte (jwelte@purdue.edu 812-598-7746). Purdue University will not provide medical treatment or financial compensation if you are injured or become ill as a result of participating in this research project. This does not waive any of your legal rights nor release any claim you might have based on negligence.

The following disclosure(s) is(are) made to give you an opportunity to decide if this(these) relationship(s) will affect your willingness to participate in the research study.

**Will information about me and my participation be kept confidential?**

Audio recordings will be transcribed, and then destroyed within 30 days of completing the interview. Notes taken by the interviewer will not include identifiable information. The apps will not ask for any personal information. User accounts will not be required to use any of the apps. The apps can synchronize to cloud storage services. This functionality is not being tested, and will be disabled. If for any reason some data is uploaded to cloud storage, it will be deleted along with all data store locally on the devices immediately following the interview.

You will be instructed to enter hypothetical data. If, for some reason you respond with any identifiable information, it will be de-identified before transcription. The only documentation of participation will be the signed consent forms, which will be virtually impossible to match to your responses.

The session transcriptions are the raw data which is very important to save, and will thus be stored indefinitely. The interview transcriptions, notes and consent forms will be stored in a locked desk drawer in Jonathan Welte's office until the end of the semester when they will be moved to a locked file cabinet in Dr. Buckmaster's office. Dr. Buckmaster's access to the files will be restricted until final semester grades are posted to limit the potential of undue influence on the student participants.

The project's research records may be reviewed by Office for Human Research and by departments at Purdue University responsible for regulatory and research oversight.

**What are my rights if I take part in this study?**

Your participation in this study is voluntary. You may choose not to participate or, if you agree to participate, you can withdraw your participation at any time without penalty or loss of benefits to which you are otherwise entitled.

**Who can I contact if I have questions about the study?**

If you have questions, comments or concerns about this research project, you can talk to one of the researchers. Please contact Dr. Dennis Buckmaster (dbuckmas@purdue.edu 765-496-9512) or Jonathan Welte (jwelte@purdue.edu 812-598-7746).

If you have questions about your rights while taking part in the study or have concerns about the treatment of research participants, please call the Human Research Protection Program at (765) 494-5942, email (irb@purdue.edu) or write to:  
Human Research Protection Program - Purdue University  
Ernest C. Young Hall, Room 1032  
155 S. Grant St.,  
West Lafayette, IN 47907-2114

**Documentation of Informed Consent**

I have had the opportunity to read this consent form and have the research study explained. I have had the opportunity to ask questions about the research study, and my questions have been answered. I am prepared to participate in the research study described above. I will be offered a copy of this consent form after I sign it.

---

Participant's Signature

---

Date



---

Participant's Name

---

Researcher's Signature

---

Date

Appendix F IRB Approval LetterHUMAN RESEARCH PROTECTION PROGRAM  
INSTITUTIONAL REVIEW BOARDS

**To:** DENNIS BUCKMASTER, ABE  
**From:** JEANNIE DICLEMENTI, Chair  
Social Science IRB  
**Date:** 12/16/2013  
**Committee Action:** Approval  
**IRB Action Date** 12/13/2013  
**IRB Protocol #** 1310014085  
**Study Title** Usability and Utility Study of OpenAgToolKit Apps  
**Expiration Date** 12/12/2014

Following review by the Institutional Review Board (IRB), the above-referenced protocol has been approved. This approval permits you to recruit subjects up to the number indicated on the application form and to conduct the research as it is approved. The IRB-stamped and dated consent, assent, and/or information form(s) approved for this protocol are enclosed. Please make copies from these document(s) both for subjects to sign should they choose to enroll in your study and for subjects to keep for their records. Information forms should not be signed. Researchers should keep all consent/assent forms for a period no less than three (3) years following closure of the protocol.

**Revisions/Amendments:** If you wish to change any aspect of this study, please submit the requested changes to the IRB using the appropriate form. IRB approval must be obtained before implementing any changes unless the change is to remove an immediate hazard to subjects in which case the IRB should be immediately informed following the change.

**Continuing Review:** It is the Principal Investigator's responsibility to obtain continuing review and approval for this protocol prior to the expiration date noted above. Please allow sufficient time for continued review and approval. No research activity of any sort may continue beyond the expiration date. Failure to receive approval for continuation before the expiration date will result in the approval's expiration on the expiration date. Data collected following the expiration date is unapproved research and cannot be used for research purposes including reporting or publishing as research data.

**Unanticipated Problems/Adverse Events:** Researchers must report unanticipated problems and/or adverse events to the IRB. If the problem/adverse event is serious, or is expected but occurs with unexpected severity or frequency, or the problem/event is unanticipated, it must be reported to the IRB within 48 hours of learning of the event and a written report submitted within five (5) business days. All other problems/events should be reported at the time of Continuing Review. We wish you good luck with your work. Please retain copy of this letter for your records.

Appendix G IRB Approved Personal Interview Script

Hi, \_\_\_\_\_. My name is Jonathan Welte, and I'm going to be walking you through this session.

You might already know, but let me explain why we've asked you for an interview.

We're testing a farm management information system that our research group has been working on so we can see what it's like for actual farm employees to use it.

I want to make it clear right away that we're testing the *software*, not you. You can't do anything wrong here so there's no reason to worry about making mistakes. Your participation in this session is completely voluntary. You may refrain from answering any question that you don't feel comfortable answering, and you may withdraw from the session at any time. The session will last approximately one hour, and I'll try to keep session moving so we don't go over.

We want to hear exactly what you think, so please don't worry that you're going to hurt our feelings. Honesty will help us make improvements for future changes.

As we go along, I'm going to ask you to think out loud to tell me what's going through your mind. This will help us. I want to let you know that I may not show agreement, but don't let this discourage you. As the observer I don't want to influence your opinion.

If you have questions, just ask. I may not be able to answer them right away, since we're interested in how people do when they don't have someone around to help

immediately, but I will try to answer any questions you still have when we're done. We have quite a bit to do, but we'll keep it moving.

You may have noticed the recording equipment. With your permission, I'm going to record our conversation and the images on the screen. The recording will be used only to help me correctly transcribe this session because I might not be able to take notes. The screen images will help me describe the usage situation. The recordings will not be seen by anyone outside of our research group which includes me and Professors Dennis Buckmaster and Mark Tucker.

Do you have any questions before we begin?

[Pause for questions]

Before we look at the software, let's start with a few questions to help me understand your background with farm management information systems, mobile devices and apps. Our app development has been strictly limited to the Android operating system. A background with Android is not necessary to use our apps, but there are some Android user interface conventions we used that I can explain when the time comes, if needed. As an Apple user, myself, I understand the learning curve associated with learning a different phone operating system.

Possible interview questions for the user to determine experience level:

- Can you describe your role on the farm?
- How many years have you been working on a farm?

-Would you consider yourself an avid mobile device user? You might use the range of new user 'just replaced my old phone with my first smartphone' to an avid user 'I don't even use my home computer because everything is on my tablet'.

-How many years have you had a smartphone or tablet?

-How do you use your phone for any farming related tasks during a normal day? Unusual day?

-Do you have any favorite apps?

-Do you have experience with devices running Android?

-How do you feel about storing farm related information in the cloud?

-Can you describe the method of record keeping your operation utilizes currently for information such as planting and harvest records, field notes, and others?

-Is there anything about the methods you use now that your operation must have to continue to function? Is there anything about it that frustrates you?

Great, let's start with an app for marking rocks in the field to be removed; we call it the Rock App.

[Hand over device running the Rock App]

First, I'll ask you to look at the app and tell me what you think you could use it for before you click on anything.

What would you try to do first?

What stands out on the screen that might be important?

Can you explain what each icon would do if you clicked it?

This app will help you mark rocks that pop up in your fields, as well as share their location with other farm employees so that they can remove them.

[Observe interest]

[If they didn't get too excited about it and explore, I would direct them to try various features]

Imagine yourself planting or chiseling one afternoon. This app would allow you to communicate the location of rocks that need to be removed before they cause damage to your equipment. You might even find other things, besides rocks, you'd mark with the app.

Does this app have any use on your farm?

[Observe usage, Collect device]

Next, let's use an app for keeping track of planting progress; we call it the Planting App.

[Hand over device running the Planting App]

First, I'll ask you to look at the app and tell me what you think you could use it for before you click on anything.

What would you try to do first?

What stands out on the screen that might be important?

Can you explain what each icon would do if you clicked it?

This app will help you maintain correct and complete planting records, as well as, any associated notes you might want to make.

[Observe interest]

[If they didn't get too excited about it and explore, I would direct them to try various features]

Why don't you try to add a field to the planting app and make a planting record for it?

Let's say a new employee, Thomas, planted the field on May 1<sup>st</sup> of this year. Feel free to add anything else to the record that your farm normally writes down for planting records.

Imagine yourself driving by a field and noticing half of the corn is a foot taller and greener than the rest. This app would allow you to find out what was different with the planter set up. You could find out that the planter was out of starter, or the operator switched seed half way through. You'll find the information you need in your pocket instead of in a notebook on the stack in the office.

Does this app have any use on your farm?

[Observe usage, Collect device]

Finally, let's start with an app for making general notes about your fields; we call it the Field Notebook App.

[Hand over device running the Field Notebook App]

First, I'll ask you to look at the app and tell me what you think you could use it for before you click on anything.

What would you try to do first?

What stands out on the screen that might be important?

Can you explain what each icon would do if you clicked it?

This app will help you maintain a list of all your fields, as well as, any associated notes you might want to record throughout the year. To facilitate this study, the app has been set up with some test fields, but please feel free to add some. Anything you enter into the apps will be deleted after the interview. Again, try to think out loud so that we know how you're thinking about using the app. Feel free to explore the app. Keep in mind that you can't do anything wrong .

[Observe interest]

[If they didn't get too excited about it and explore, I would direct them to try various features]

Why don't you try to find a nearby field and add it to the app? Maybe there's a section in the top of the field that you always find wet.

Imagine yourself scouting several fields in a day. This app would allow you to make very quick and detailed notes about fertilizer needs or drainage problems that you might forget before you get back to the farm.

Does this app have any use on your farm?

[Observe usage, Collect device]

We're pretty excited about how far the project has come since we first starting talking about the problems we saw with how some farms maintain records. I'd like to ask you a couple questions regarding implementation of an apps-based farm management information system. Then, I'll answer any questions you might have.

Possible interview questions for the user to determine software usability:



- Is there anything that you do now that these apps would improve? How?
- Are there any things that you don't do now that you would start doing different if you implemented these?
- Can you explain how this might fit into your farming operation?
- Can you show me some things that frustrated you about the software? Maybe something that didn't work as you expected it to, or something that took too long to complete
- Is there missing functionality that your operation would require?
- Can you think of ways these apps would improve the record keeping on your farm?
- Can you explain a situation where these apps would help you make better decisions?

I heard you make some very interesting comments regarding how you see the apps being used on your farm. Some of the ideas you had were ones that we hadn't even thought of, and that's great because we wanted the apps to be extremely useful. The apps are designed such that they can be used for your farm's needs even if that's not the intended purpose. That's one thing we knew we'd run into as we talked to more people like yourself. I want to thank you for taking the time to talk with me today. That's all I had planned for today, but we have some time left over if anything we talked about sparked other discussion topics.

## Appendix H Other Research Contributions

In addition to the principal project covered by the thesis, another research contribution was the design of the electronics enclosure for the ISOBlue project ([www.isoblue.org](http://www.isoblue.org)). The project aims to create a completely open source, inexpensive means for getting data from any ISO11783-compliant tractor to a Bluetooth-equipped mobile device in real-time. The mobile device can then upload the data to the cloud over its existing cellular connection (Welte, et al., 2013 b.).

The enclosure design was developed using the 3D modeling software, PTC Creo. The files were sent to the 3D printing company Shapeways ([shapeways.com](http://shapeways.com)). Figure 41 shows version 1 of the ISOBlue enclosure fully assembled with the electronic components. The enclosure was printed by Shapeways using their Strong & Flexible Plastic Material for approximately \$250.

Version 2 of the enclosure was an attempt to lower the manufacturing costs and reduce the physical footprint of the enclosure. The two-piece design with clips to securely close the enclosure was reused. The new design utilized a dual-level tray design to stack components rather than lay them out on a single tray as shown in Figure 42, 43, and 44.

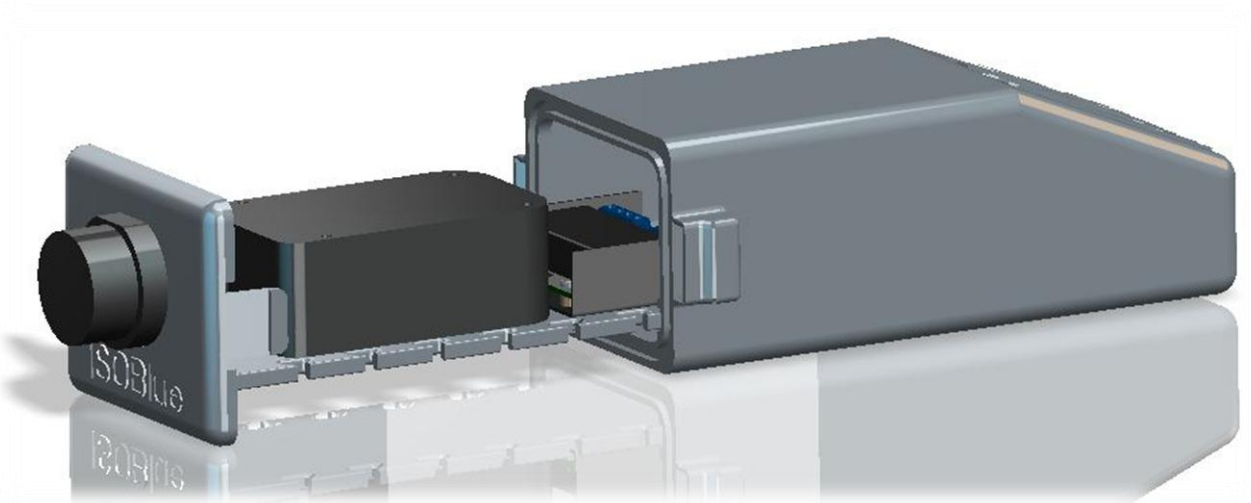

Figure 41: ISOBlue enclosure version 1 shown with component tray slid out.



Figure 42: ISOBlue enclosure version 2 shown with dual level component tray slid out.



Figure 43: ISOBlue enclosure version 2 rear view to show the ISOBlue name

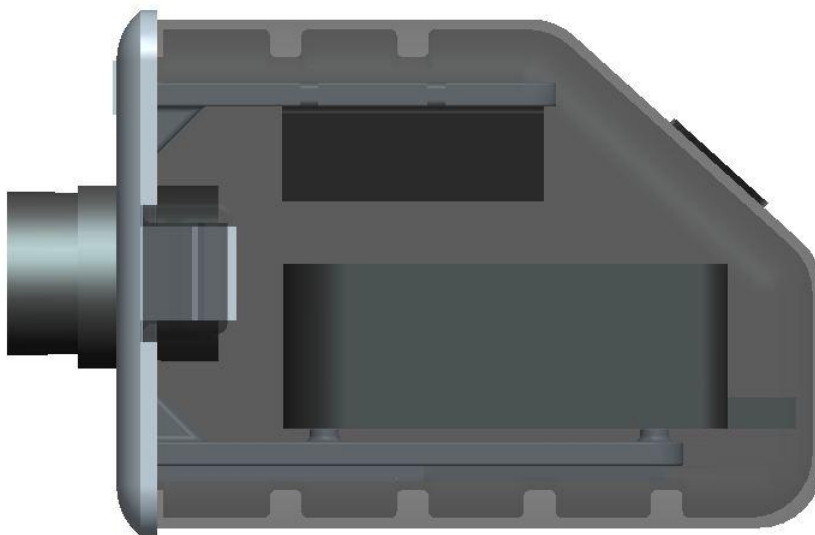

Figure 44: ISOBlue enclosure version 2 with a semitransparent shell to show the internal layout