

Ground Improvement Methods Using Column- Type Techniques

102nd Annual Road School 2015

3/9/2016

Malek Smadi, Ph.D., P.E.

Principal Engineer - GEOTILL - Fishers, Indiana

msmadi@geotill.com - www.geotill.com



GEOTILL

ENGINEERING, INC.



CONTENTS

1. Column Ground Improvement Overview
2. Stone Columns
3. Soil Mixing
4. Grouting
5. Procedures Used In The Improvement Column Technology
7. Case Histories



Example of Soft Ground



Goal of Column Ground Improvement

- To increase bearing capacity, shear or frictional strength
- To increase density
- To control deformations
- To accelerate consolidation
- To decrease imposed loads
- To provide lateral stability
- To form seepage cutoffs or fill voids
- To increase resistance to liquefaction



Column Ground Improvement Types

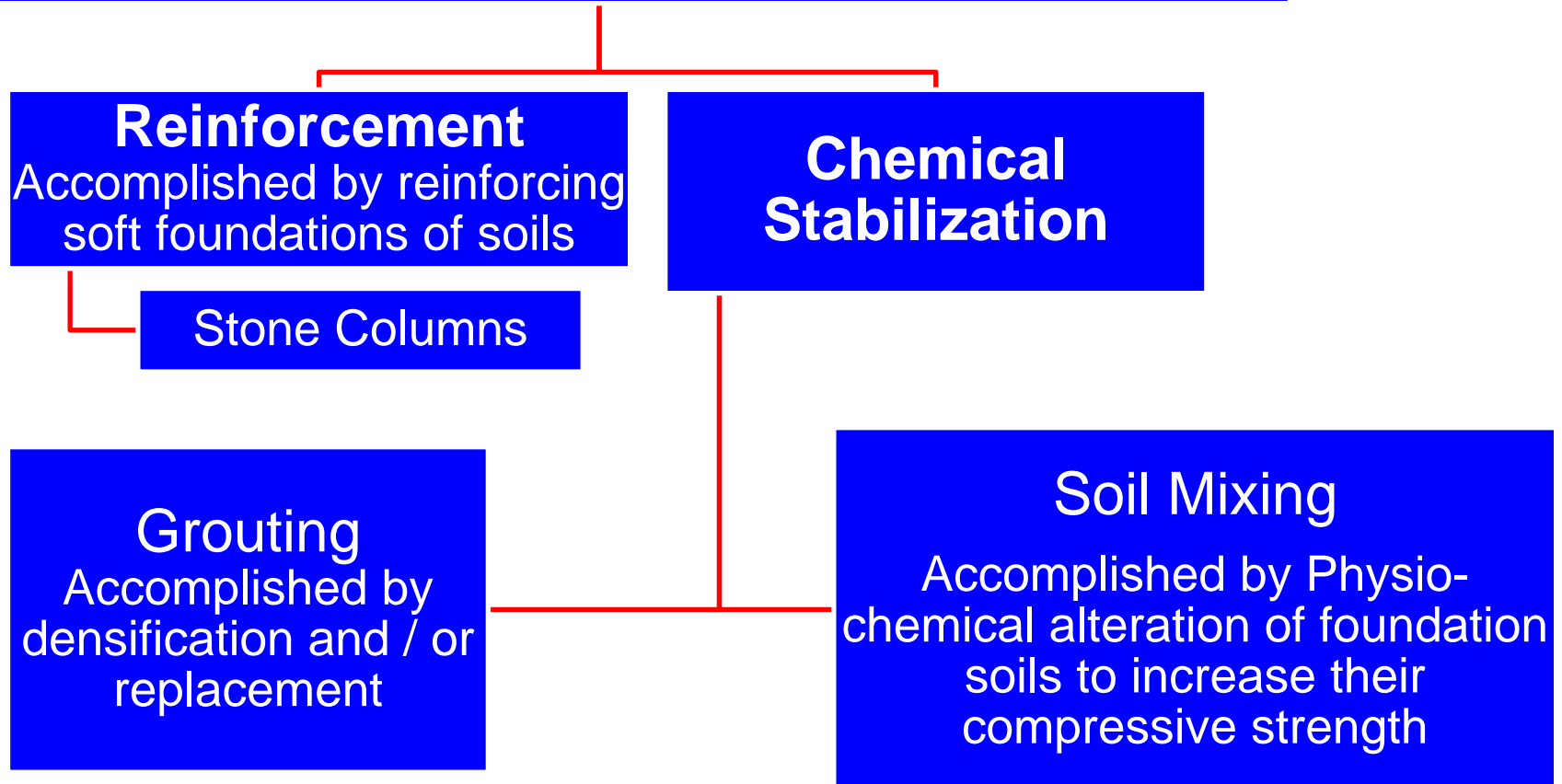

Ground Improvement

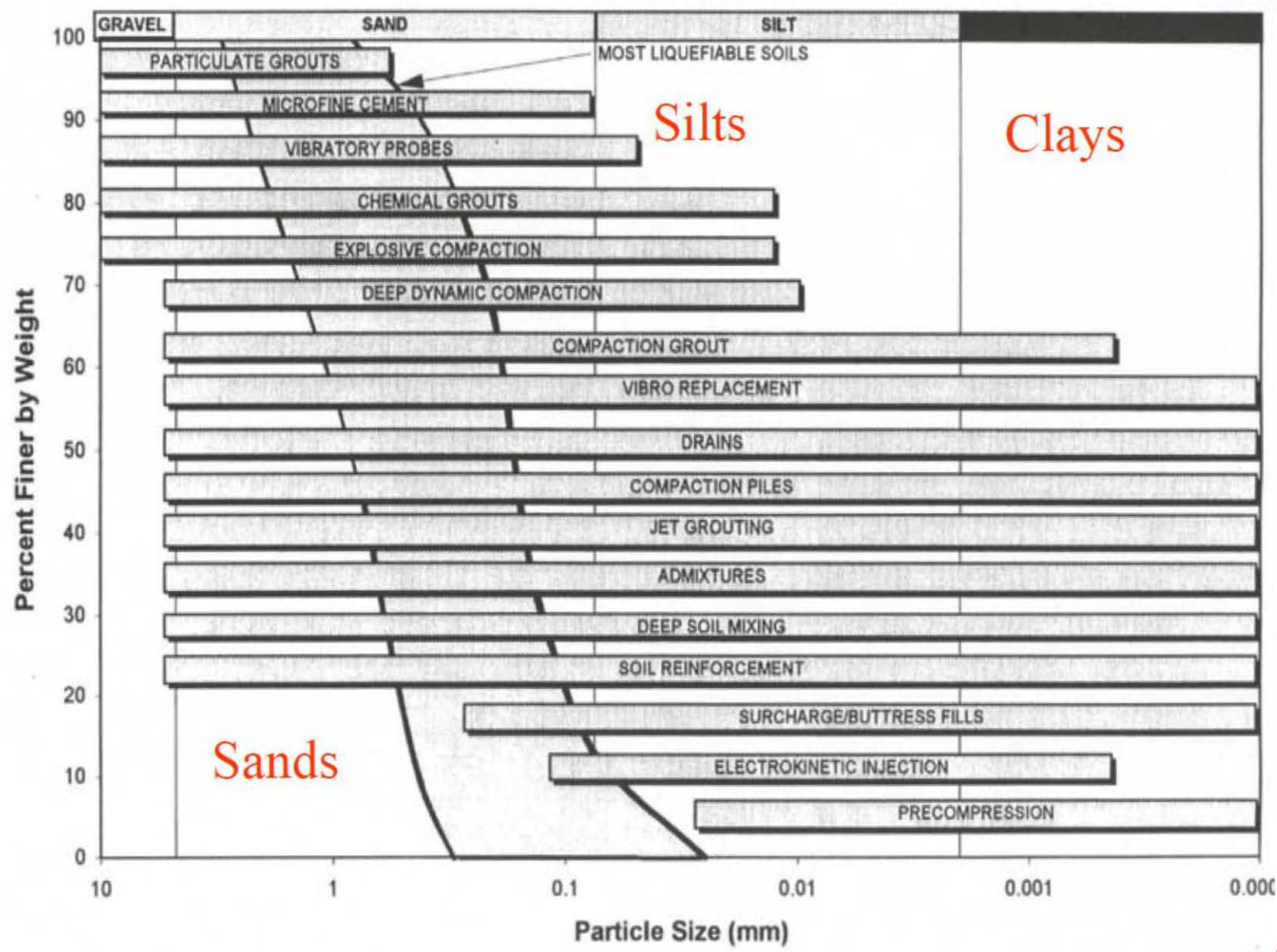

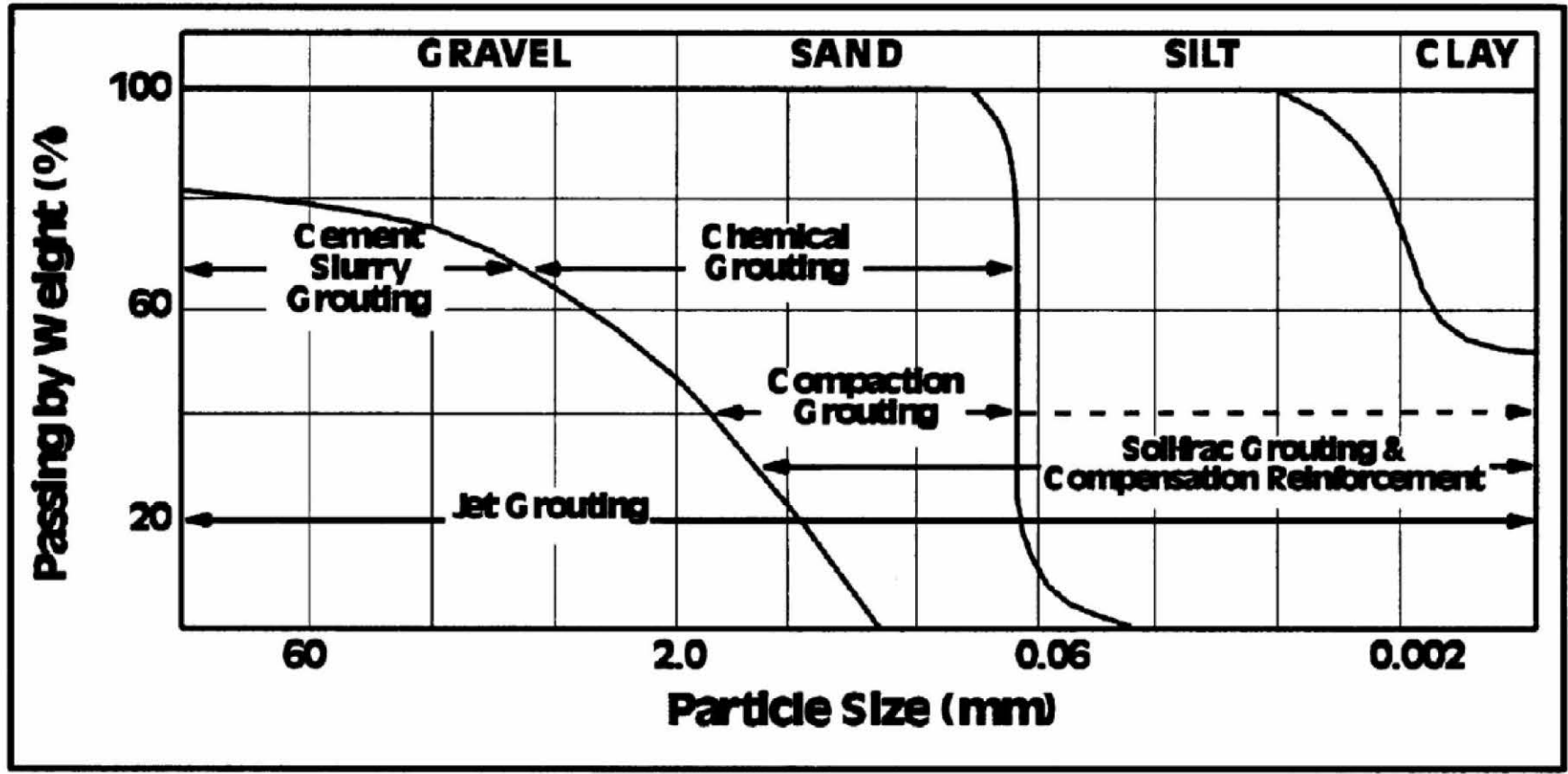

Stone Columns

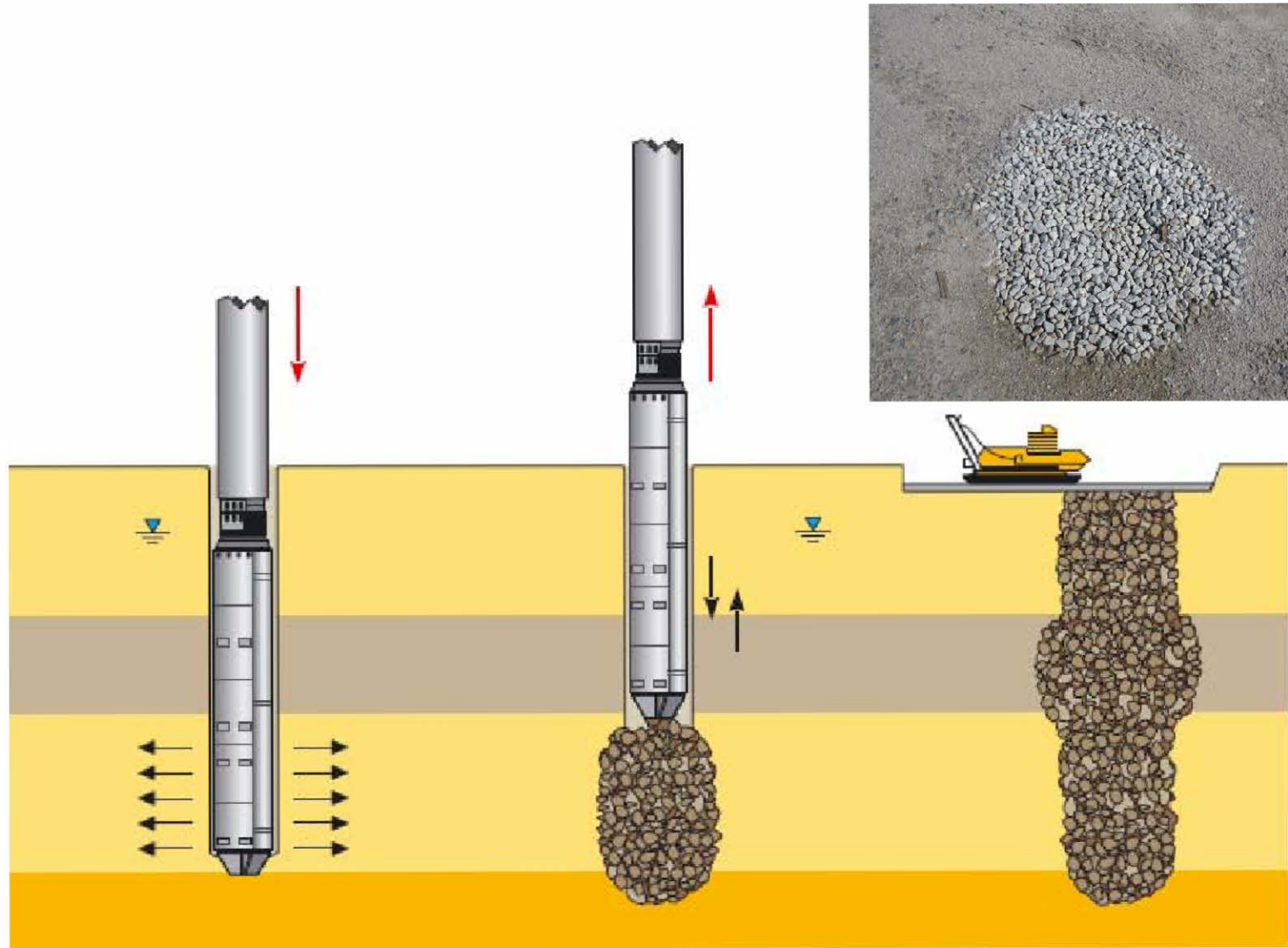

Soil Mixing Columns

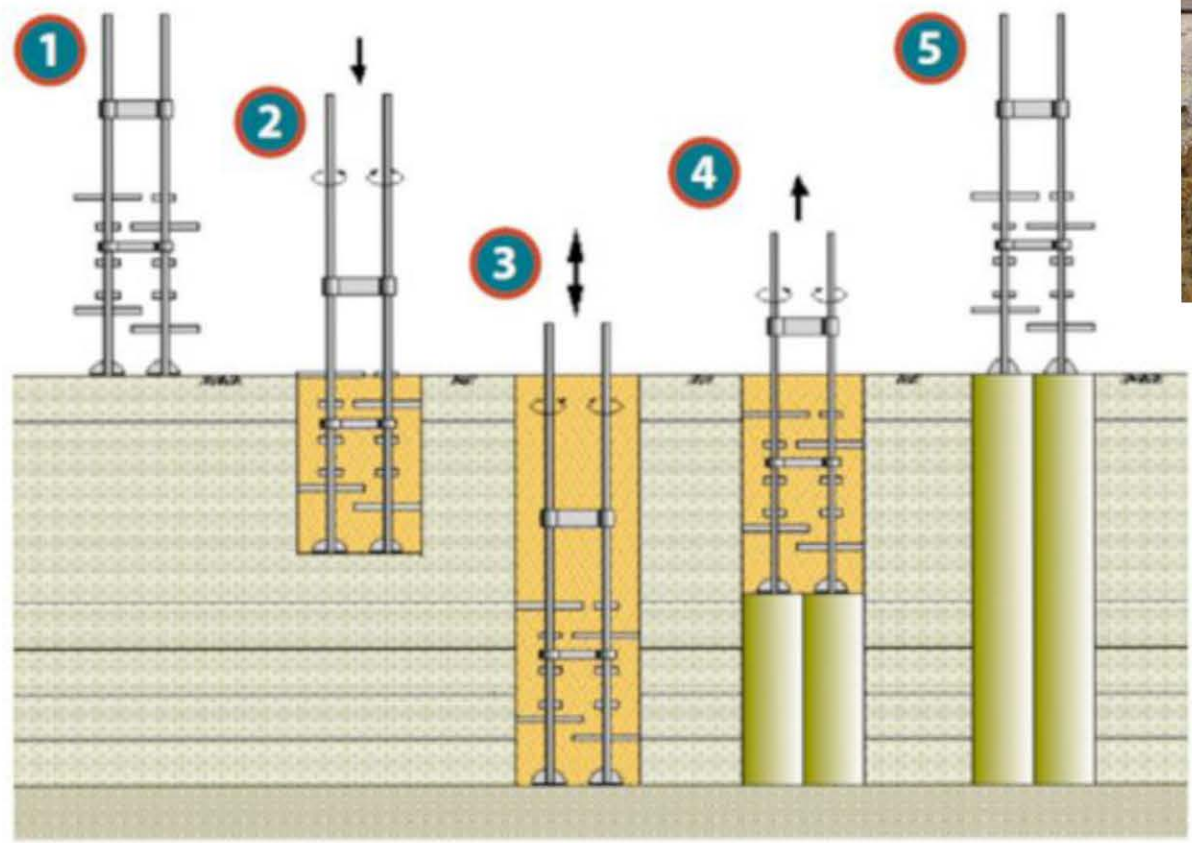

- 1** Positioning of auger tool
- 2** Drilling and mixing soil with cement grout
- 3** Bottom mixing
- 4** Withdrawing while continuing soil mixing
- 5** Complete mixed product column

Grouting Columns

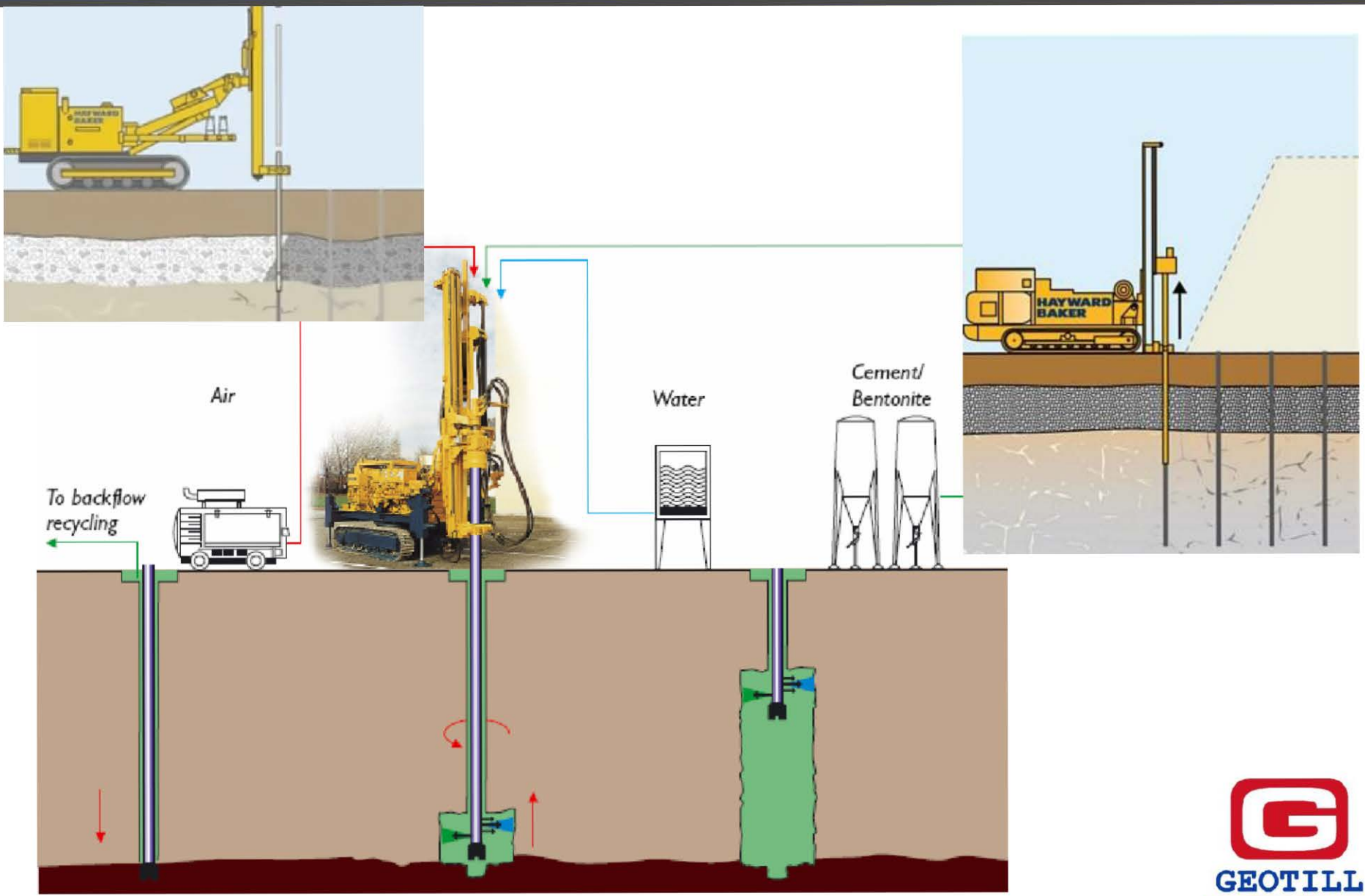

Stone Columns Types



- Aggregate Column
- Granular Piles
- Vibro Stone Column
- Rammed Stone Column
- Compacted Stone Column
- Aggregate Piers
- Sand Compaction Piles
- Geotextile Encased Columns
- Grout Stone Columns
- Vibro-Concrete Columns (VCC)

History of Stone Columns

- Used in 1830 by French Military (Hughes and Withers, 1974)
- Rediscovered in 1930's with vibroflotation of granular soils
- Early 1960's, stone columns in cohesive soils

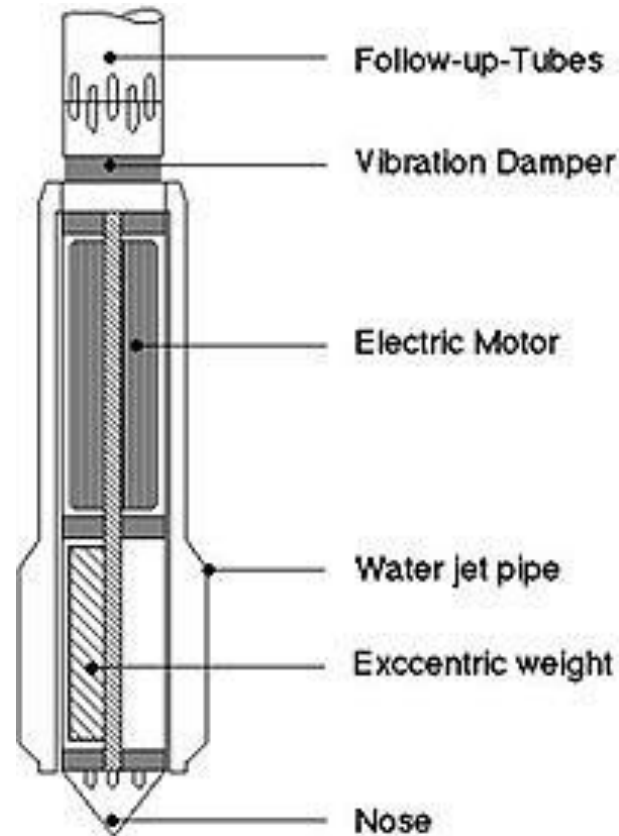



Stone Column Construction



Stone Column Construction





Applications of Stone Column

- Buildings
- Embankments
- Bridge Approach Fills
- Bridge Abutment and Foundation Support
- Liquefaction
- Improve Stability of Slopes

Goals of Stone Columns

- Densification
- Reinforcement
- Homogenization
- Load Transfer (VCCs only)
- Drainage

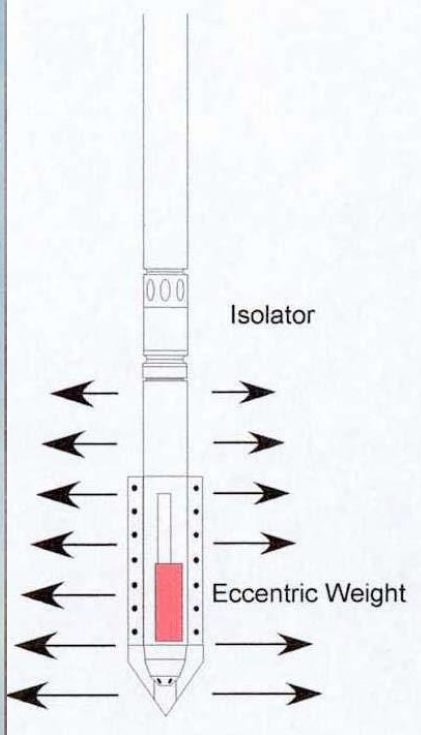
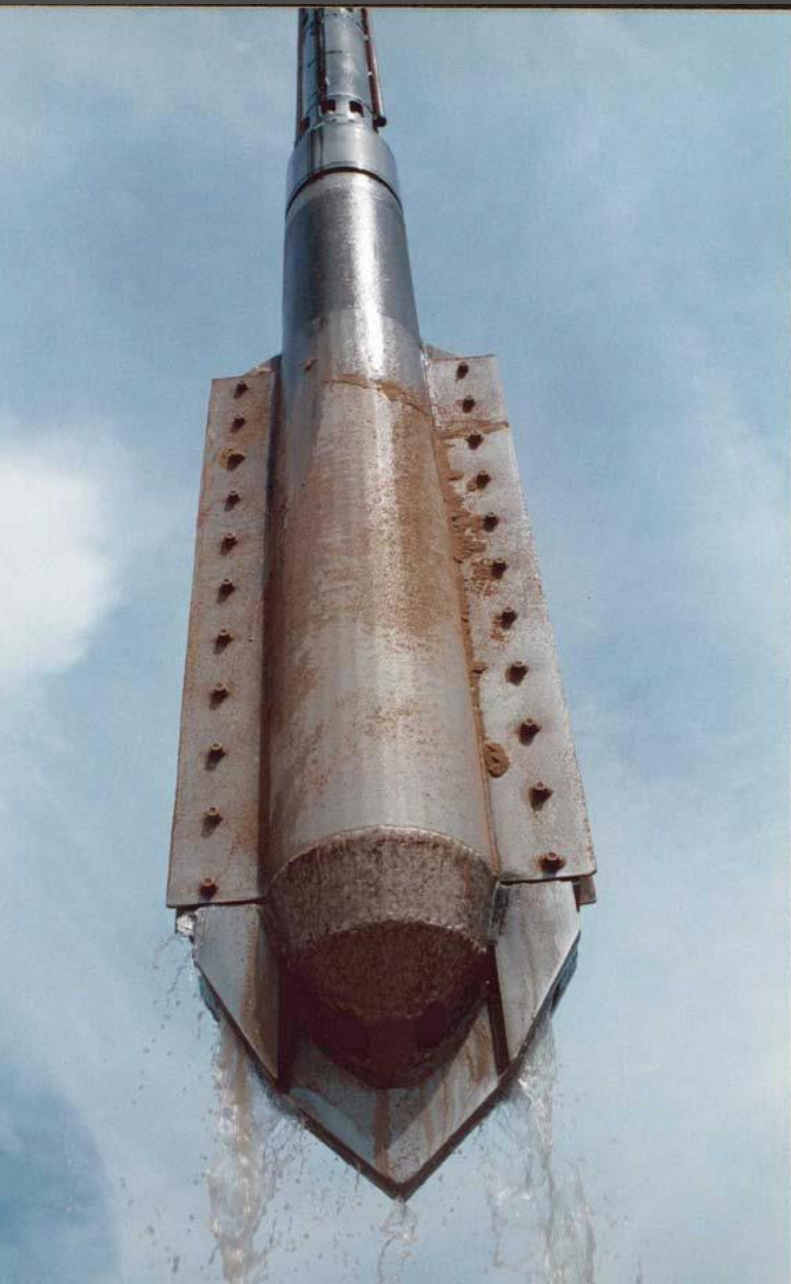

Vibratory Probe



- Increased Bearing Capacity
- Reduction of Total and Differential Settlement
- Expedites Consolidation Settlement
- Liquefaction Mitigation

Types of Stone Column Construction

- **Vibro-Replacement (Wet Top Feed) (i.e. Vibroflotation)**
 - Stone column construction using water flush.
 - Refers to the wet, top feed process in which jetting water is used to aid the penetration of the ground by the vibrator.
 - Due to the jetting action, part of the in-situ soil is washed to the surface. This soil is then replaced by the backfill material.
- **Vibro-Displacement (Dry Top and Bottom Feed)**
 - Stone column construction using compressed air and no water flush.
 - Refers to the dry, top or bottom feed process; almost no in-situ soil appears at the surface but is displaced by the backfill material.
- **Compacted Stone Column**
 - A continuous vertical dense column of interlocking aggregate grains, free of non granular inclusions.
- **Vibro-Concrete Columns**
- **Vibro-Compaction**
 - Similar to Vibro Replacement, Except Stone is not Added

Installation Techniques – Stone Columns

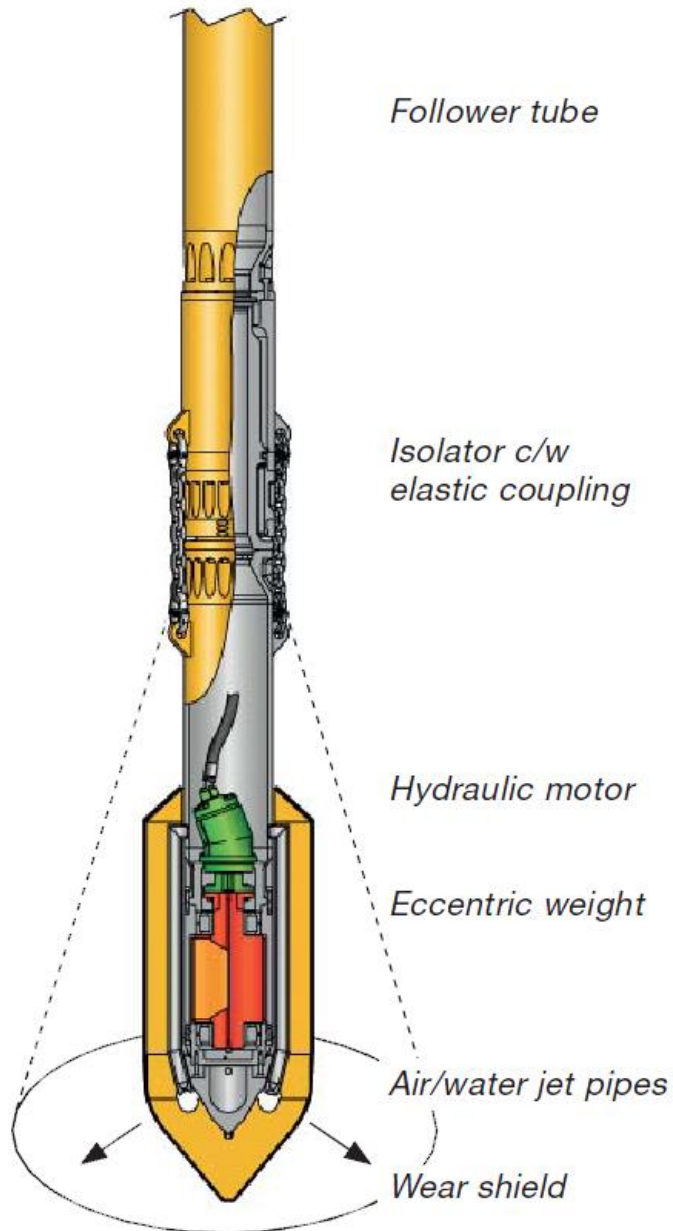

- Dry Top Feed (cohesive soils)
- Dry Bottom Feed (high water table, silty, etc.)
- Wet Top Feed (typically silts and sands below WT)



Dry Top Feed

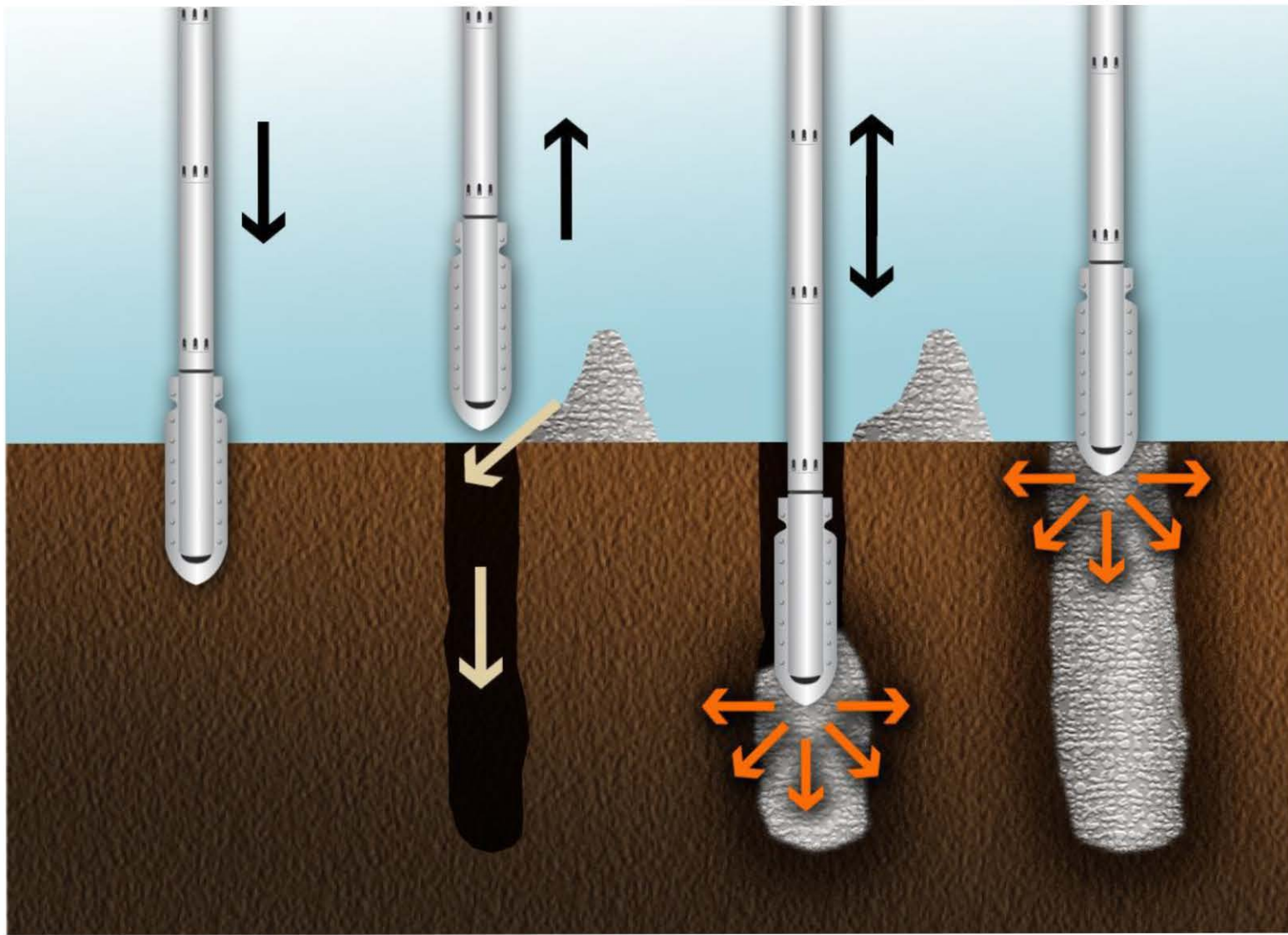



Dry Top Feed



Bottom Feed

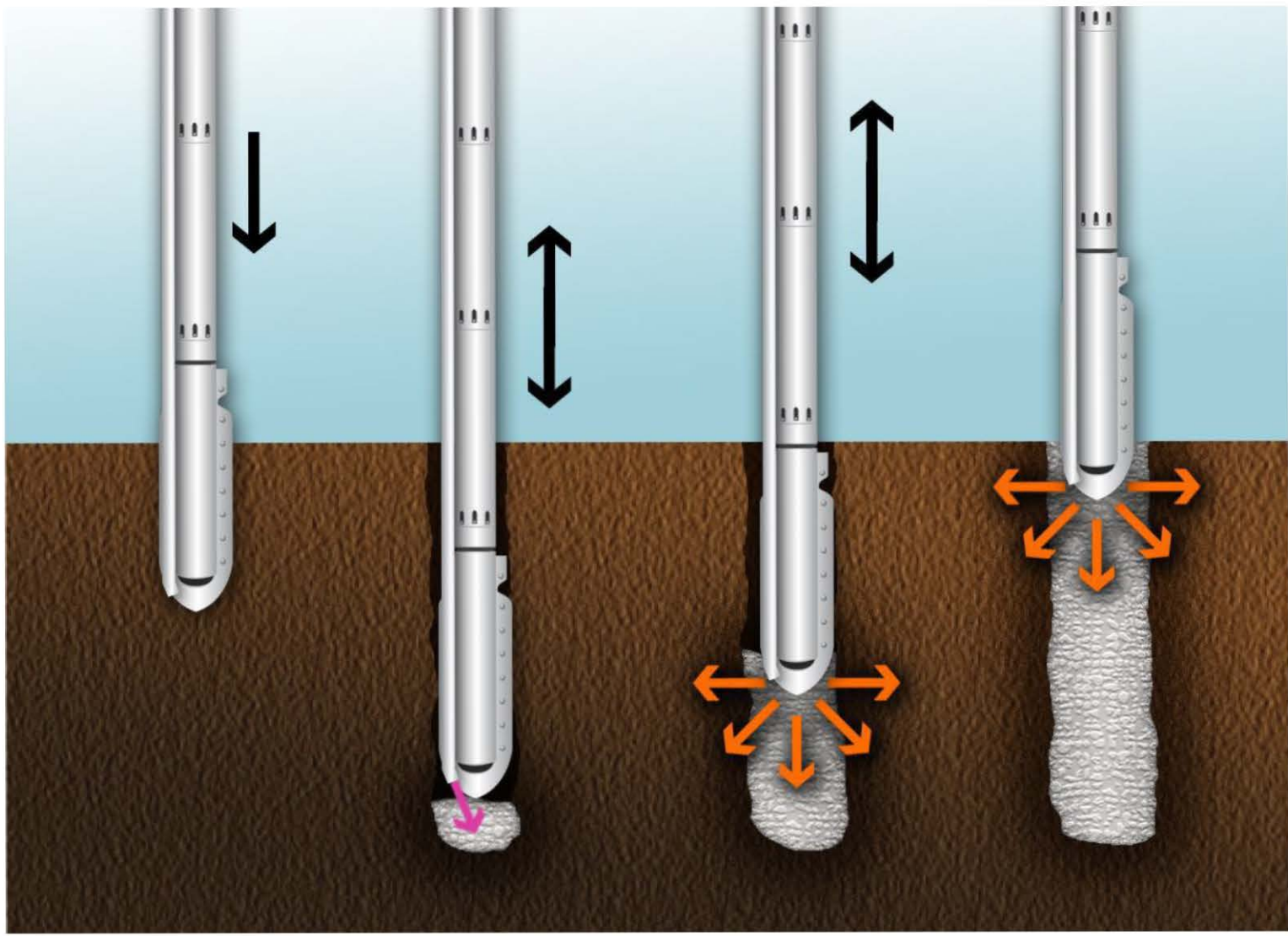



Bottom Feed



Bottom Feed



Wet Top Feed

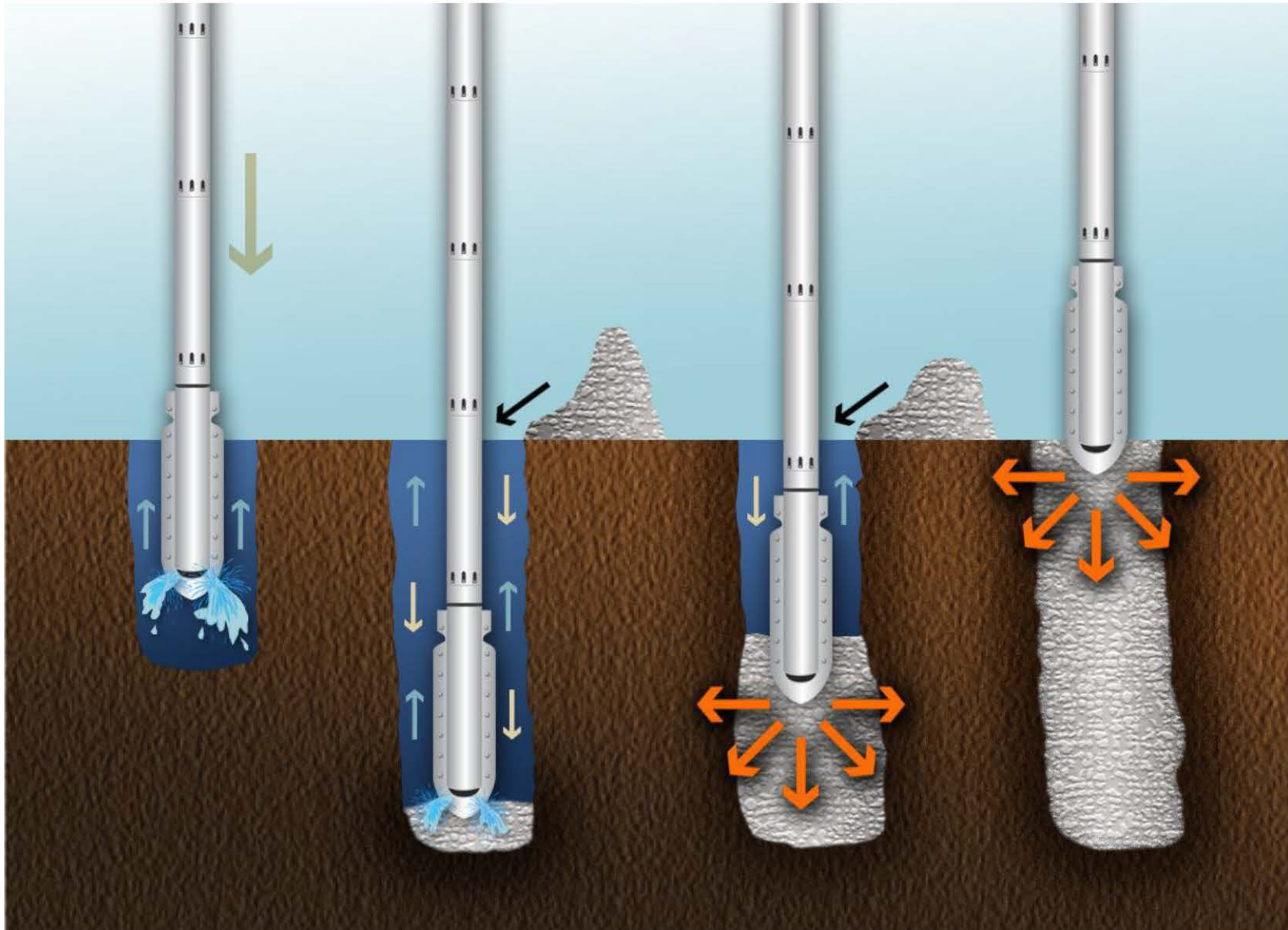



Wet Top Feed



Wet Top Feed



Compacted Stone Column

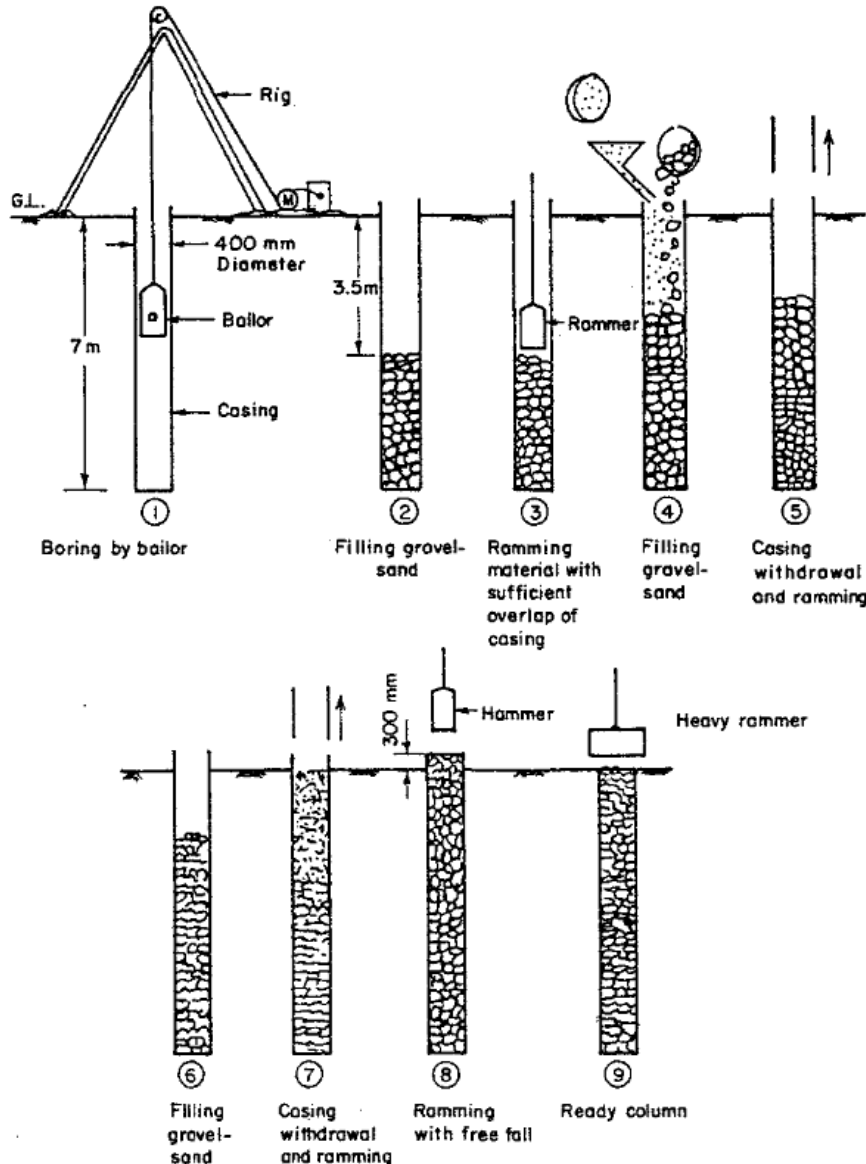

- This method is good substitute for vibrator compaction since it does not need technology
- Disturbance and subsequent remolding by the ramming operation may limit its applicability to sensitive soils.
- The method is useful in developing countries utilizing only indigenous equipment in contrast to the Vibro methods which require special equipment

Compacted Stone Column - Geopiers

- Typically 24 to 36 inches in diameter and 6 to 30 feet deep, constructed by drilling and ramming crushed rock in 12-inch lifts
- The ramming equipment consists of excavators equipped with 2,000 to 4,000 lbs hydraulic hammers with beveled tampers



Using mechanical means to improve the ground's ability to support a structure

- Vibro Stone Columns –Soft, Cohesive Soils
- Compacted Stone Columns - Soft, Cohesive Soils
- Vibro compaction -Loose, Granular Soils
- Vibro Concrete Columns or Geotextile Encased Sand Columns –Very Weak (OH, PT, etc)

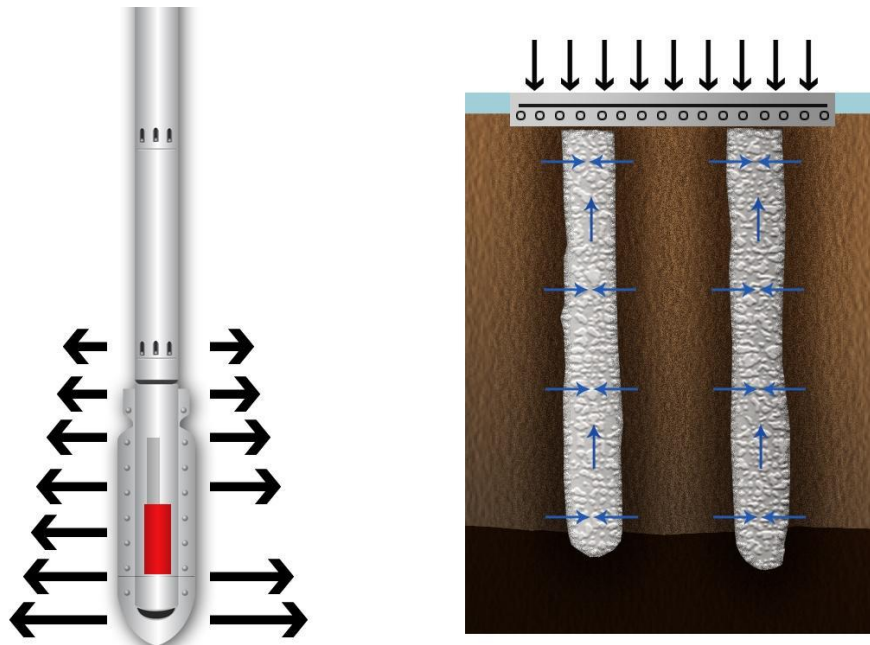

- Eliminate pre-drilling
- Avoid deep foundation
- No spoils
- Applicable to most soil types
- Quick Installation and save time
- Computer-aided QA/QC
- Save money !

Quality Control (QC) / Quality Assurance (QA)

- Electronic Monitoring
- Can record numerous variables to suit contract e.g.:
 - depth
 - packing-penetrating pressures
 - verticality
 - stone consumption
 - concrete pressure
 - time
 - pump pressure

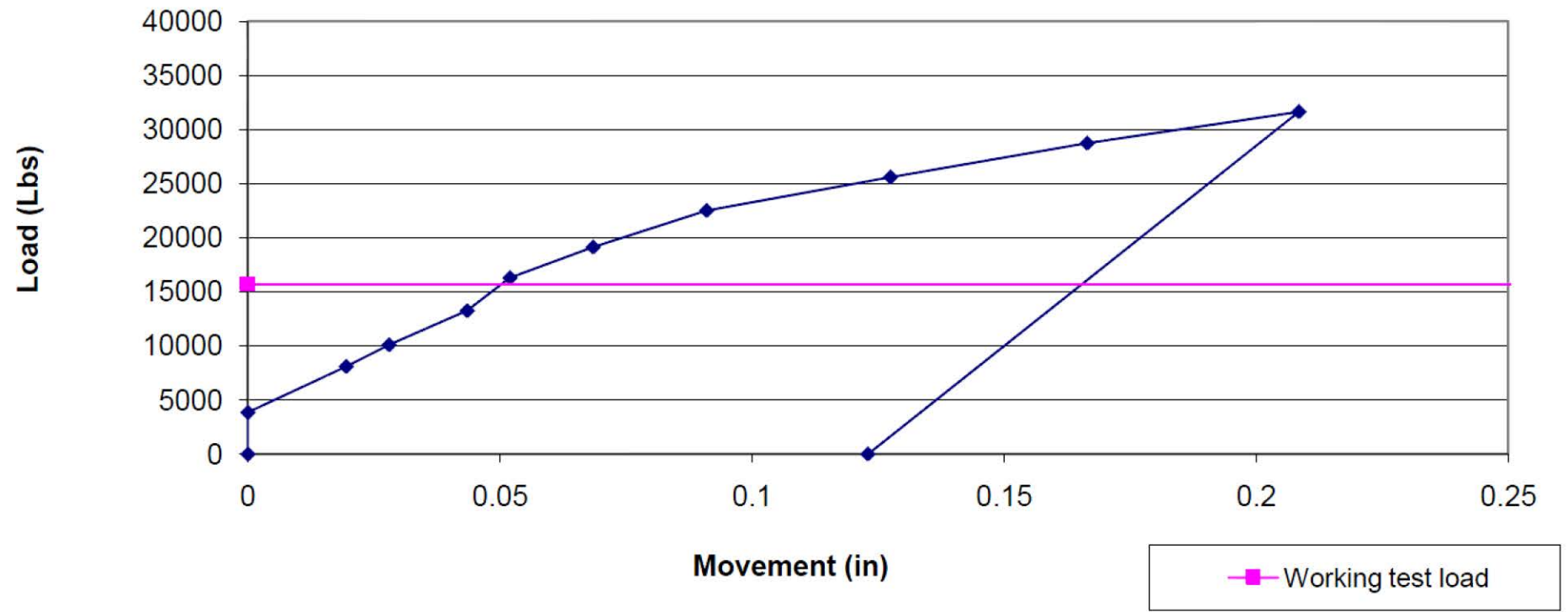

Plate Load (Modulus) Test

Kokomo Baseball Stadium



Plate Load (Modulus) Test



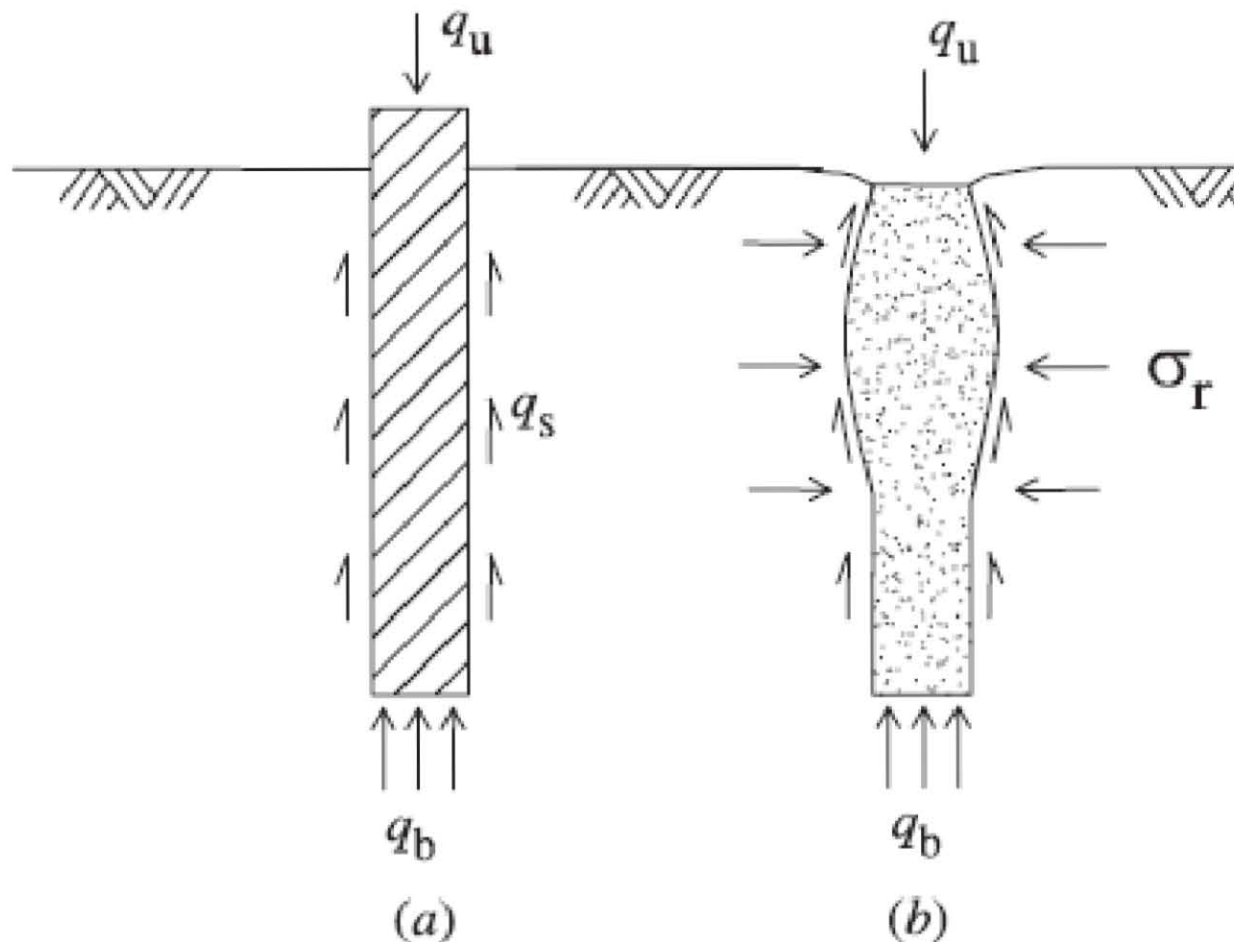

Mechanisms of load transfer for
(a) a rigid pile and (b) a stone column

Typical Column Arrangements

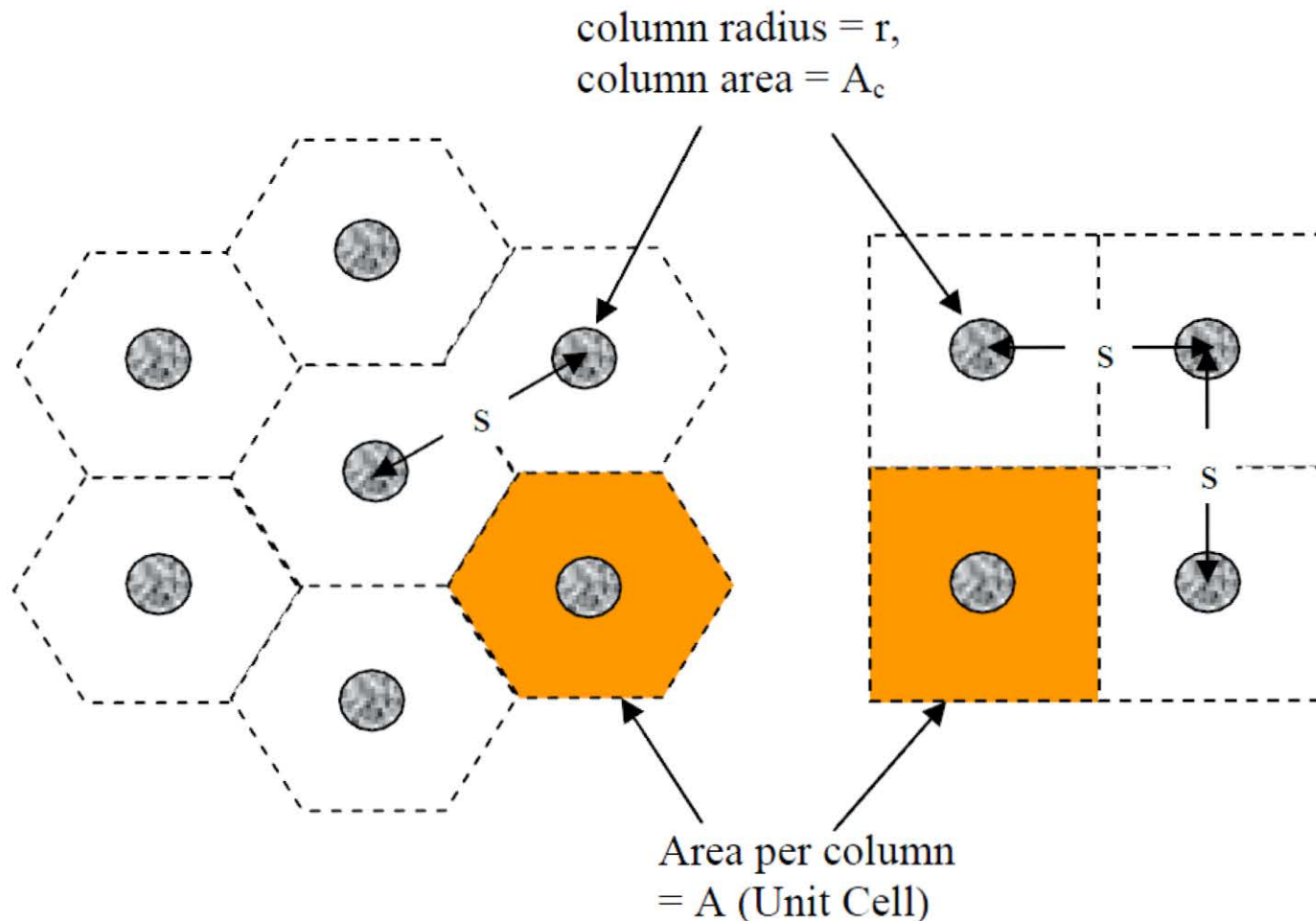

Typical column arrangements, triangular grid (left) and square grid (right)

Achievable post treatment bearing pressures are dependent on:

- a. Soil type
- b. Column diameter (vibrator type/method of installation) or column density (A_o/A_c ratio)

Typical bearing pressures:

Dry method -up to 3100 psf for soft cohesive soils
-up to 5200 psf for granular soils

Wet Method -up to 5200 psf for soft cohesive soils
-up to 8500 psf for granular soils

Reduction of Settlement

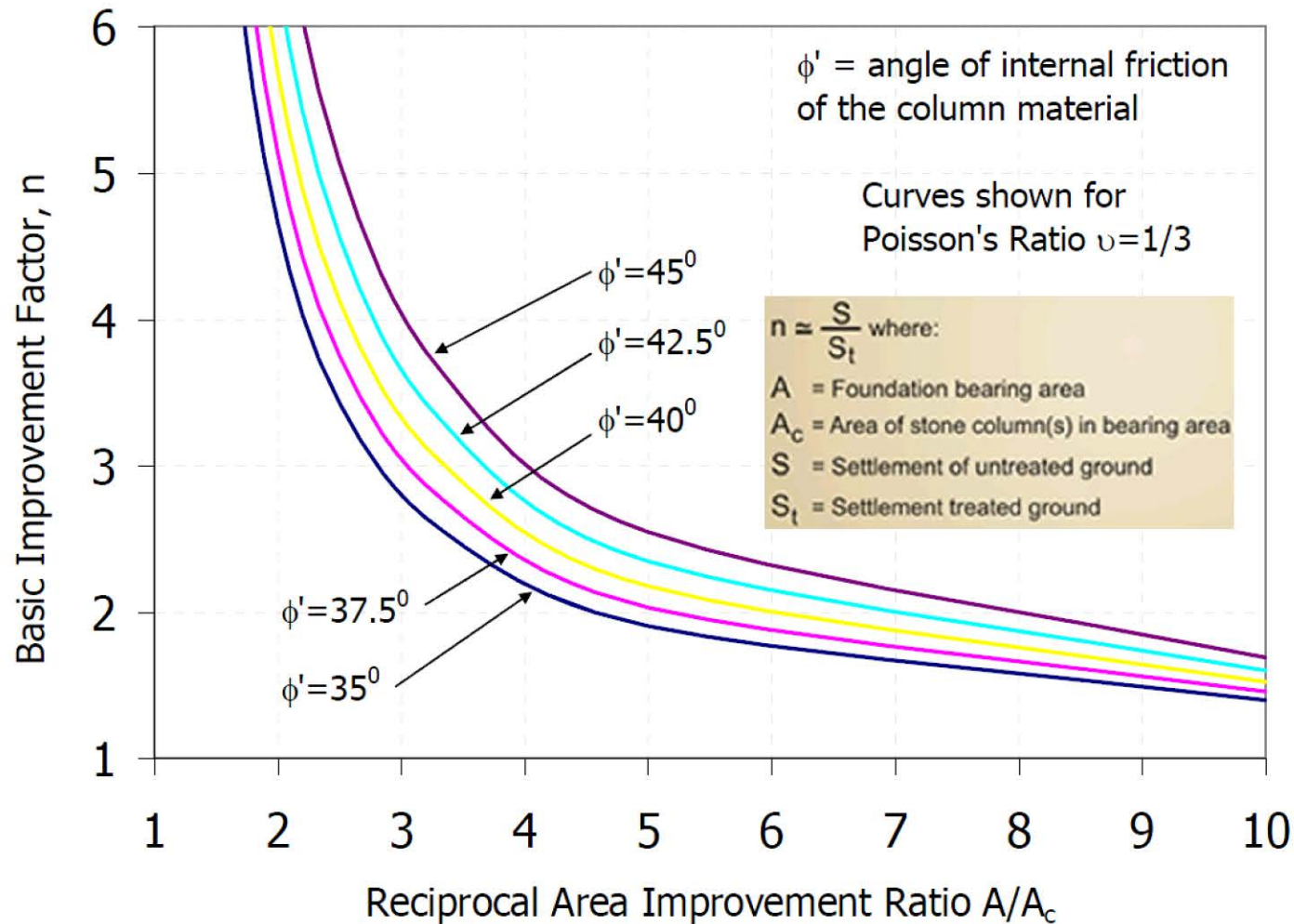

Priebe's basic improvement factor (Priebe, 1995)

Difficult Ground Conditions

- Very soft clays with C_u values < 310 psf
- Peat/degradable fills
- Obstructions and voided ground (made ground/natural)
- Fills susceptible to collapse/inundation settlements
- Non-engineered cohesive fills (<10 years)
- Contaminated soils
- Shrinkable soils
- Backfilled pits/quarries or variable fill thickness



- 420 stone columns
- Bottom feed and top feed construction



SR 37 Landslide - Indiana



SR 37
RP 11.4
Perry
County

550 piers, 30 inches in diameter – 28 to 30 ft deep



SR 37 Landslide - Indiana



US 31 and SR 38 - Indiana



Stone Columns was Under Artesian Pressure



Geotextile Encased Columns - GEC



Vibro Concrete Columns

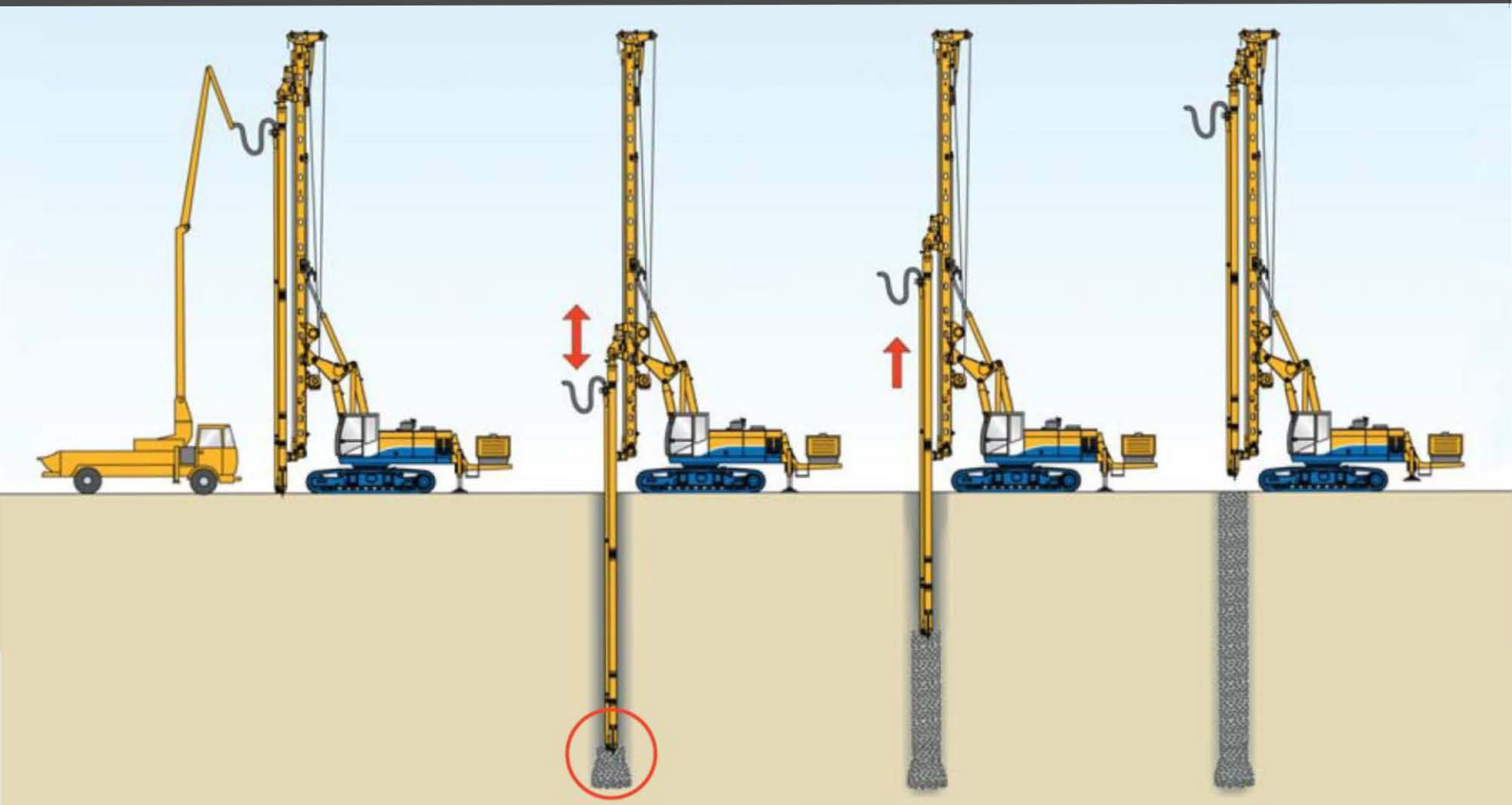

Work sequence for the construction of a vibro concrete column VCC

Vibro Concrete Columns

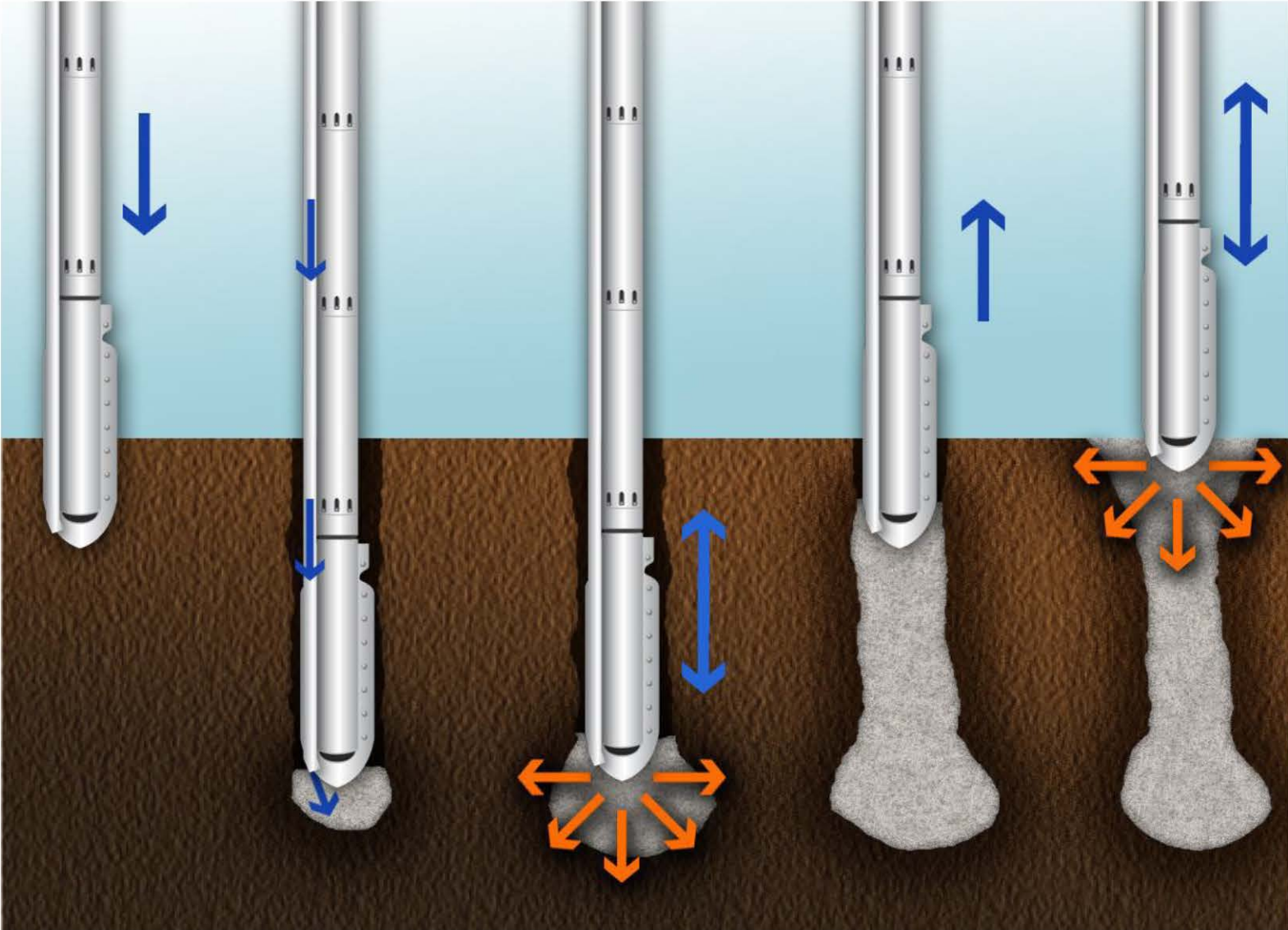

Vibro Concrete Columns



Excavated VCC column



Concrete placement for VCC column

Vibro Concrete Columns



Vibro-Compaction

- Densifying granular soil by inserting a vibrating probe into the ground
- Probe spacing ranges from 6 to 14 feet
- Suitable for sand with less than 15% fines (silt- and clay-size particles)
- Vibrator is a torpedo shaped horizontally vibrating probe, 10 to 15 feet long, and weighs about 2 tons. The probe penetrates to the design depth under its own weight assisted by water jetting



Vibrator and Water Jets

Vibro-Compaction

- The action of vibrator and water jetting reduce intergranular forces between soil particles allowing them to become denser
- The vibrator starts at the bottom of the hole and raised to treat the next interval; the procedure is repeated as backfill sand is added
- If backfill is not added, craters with diameters of 10 to 15 feet can form around vibrator



Vibro-Compaction

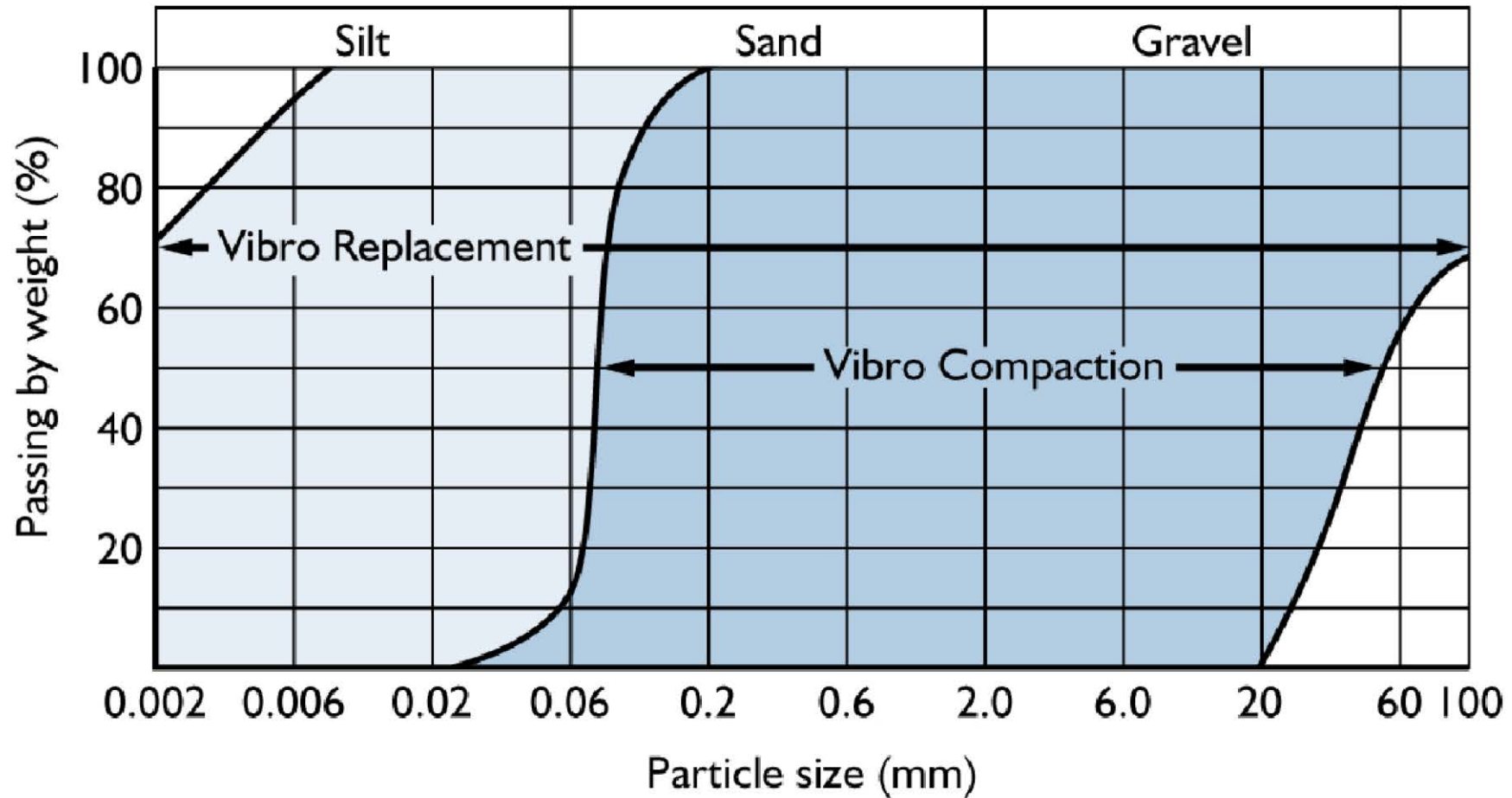

Compaction Grouting -Limitations

- Limited use in coarse grained gravels where grout cannot be prevented to enter the soil pores
- Cohesive soils that will remold or where injection causes build up of pore water pressures



Soil Mixing Columns



Soil-Cement Mixing Columns

- Mixing in-situ soil with cementitious materials using mixing shafts consisting of auger cutting heads, auger flights, or mixing paddles
- Produce soil-cement columns with higher strength, lower compressibility, and lower permeability than the native soil
- Used to improve bearing capacity and slope stability, and as shoring walls
- Typical compressive strength of cylinders ranges from 15 to 300 psi
- Typical permeability of mix ranges from 10^{-6} to 10^{-7} cm/sec

Soil Mixed Walls/Columns



- Full groundwater cutoff
- Minimal vibration (drilled)
- Can be made permanent with facing
- Larger soldier piles add stiffness
- Convenient anchor attachments



Triple
Head
Augers

Soil Mixing Columns

CSO Project Corona, NY

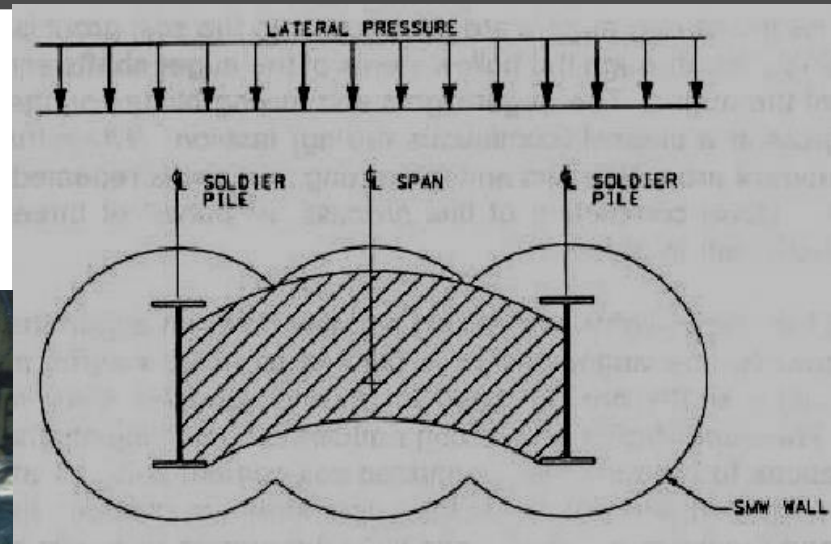

SOIL MIXED WALLS



- This is the most common method used for ground improvement that improves the characteristics of soft, high moisture content clays, peats, and other weak soils, by mechanically mixing them with dry cementitious binder to create soilcrete.
- The process is often used in high ground water conditions and has the advantage of producing practically no spoil for disposal.

Advantages And Limitations of Soil Mixing

- Applicable for most of soils
- Utilizes the existing soil
- Dewatering is not required
- Does not generate noise or vibration

- High cost of mobilization
- Accompanying auxiliary batch plant make these systems uneconomical for small projects

Grouting Columns

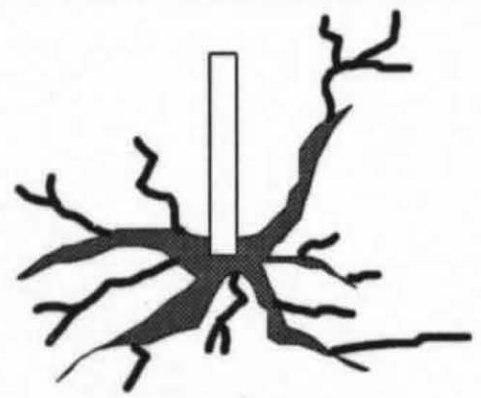

**Slurry G rout
(Intrusion)**

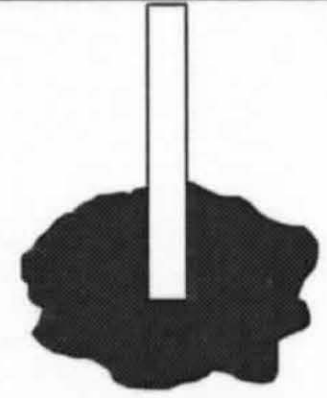

**Chemical G rout
(Permeation)**

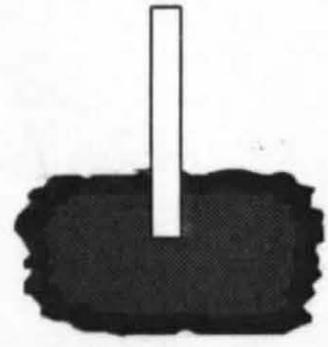

**Compaction G rout
(Displacement)**



**Jet G rout
(Erosion)**



**Fracture G rout
(Fracture)**

Compaction Grouting

- Soil improvement involving the injection, under relatively high-pressure, of a stiff grout to displace and compact soils
- The injected grout pushes the soils to the side as it forms a grout column or bulb

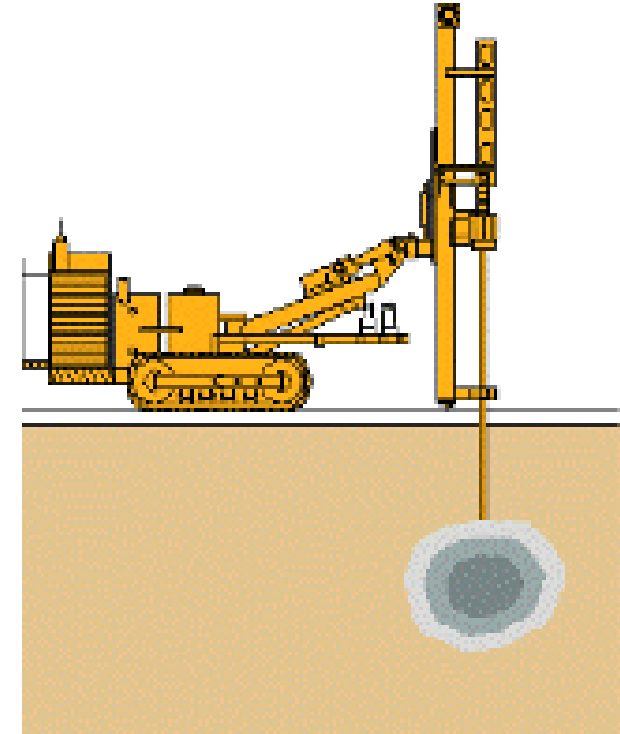
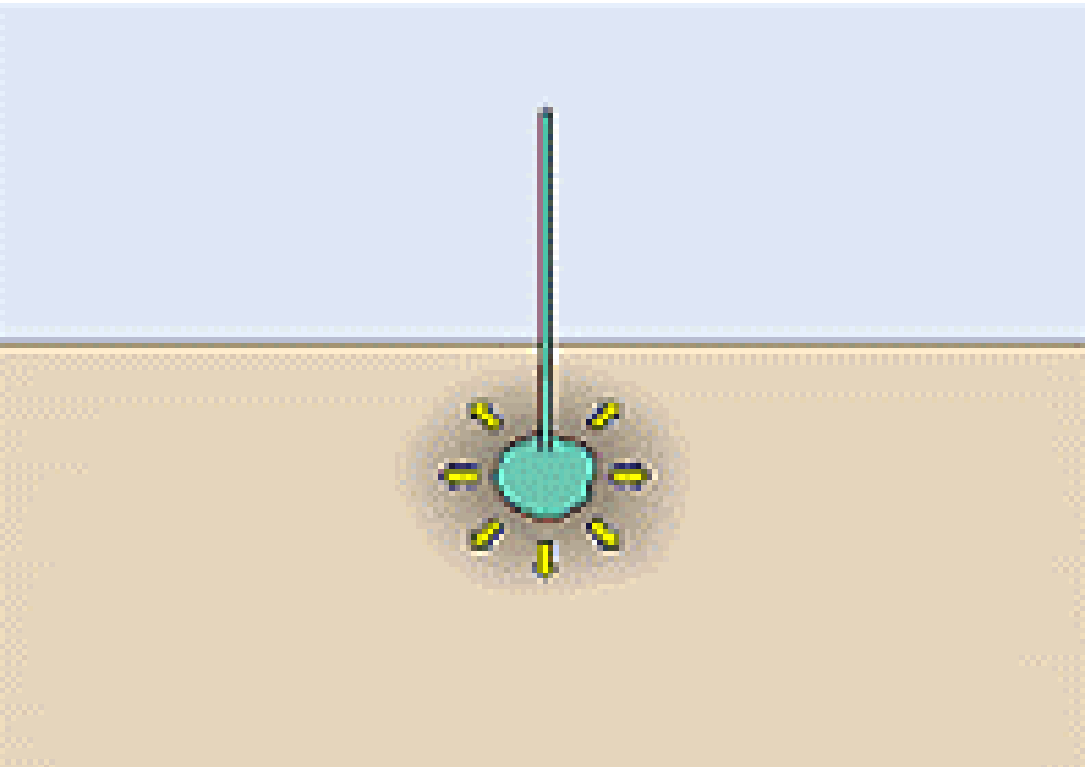

Compaction Grouting - Applications

- Reducing liquefaction potential
- Arresting foundation settlement
- Lifting and leveling structures
- Pre-construction site improvement
- Settlement control over tunnels or sinkholes

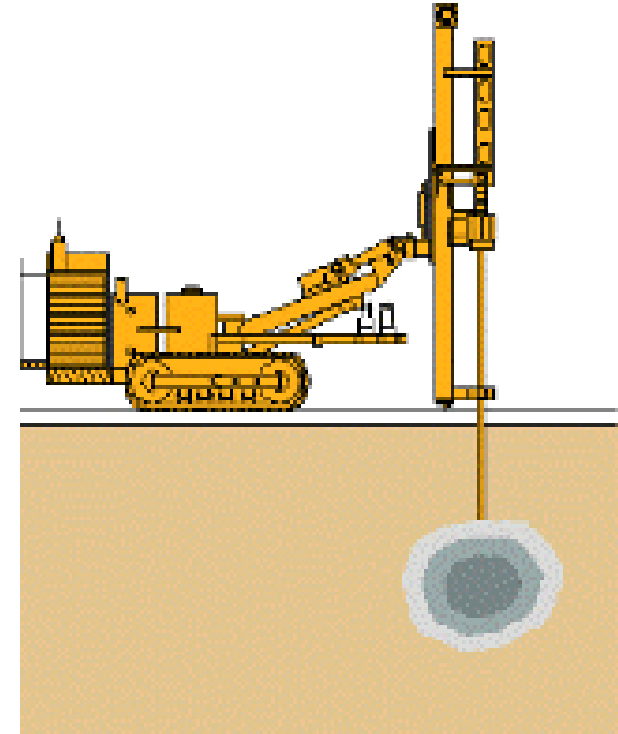

When is it typically used

- Soil compaction near existing buildings and underground services, where vibratory methods are not practical
- Very small compaction projects, where the mob/demob cost of vibro equipment is prohibitive
- Many low cost providers
- Low headroom

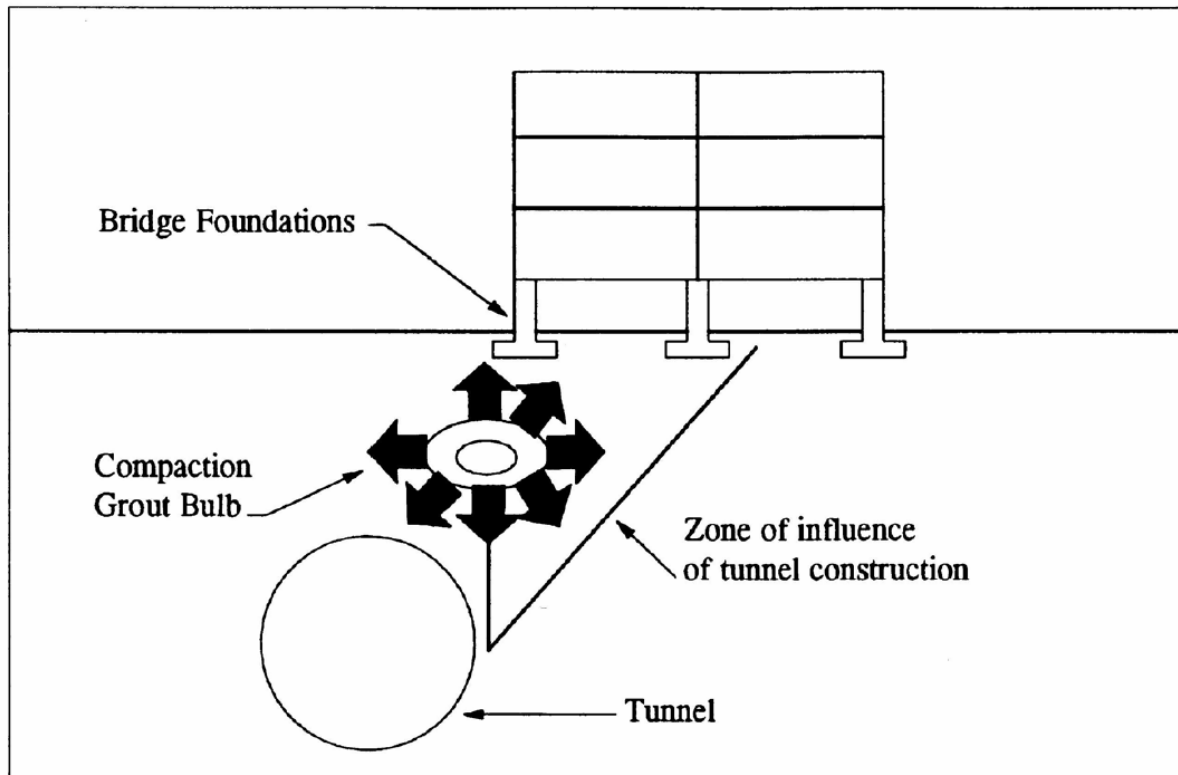

Compaction Grouting - Limitations

- Limited use in coarse grained gravels where grout cannot be prevented to enter the soil pores
- Cohesive soils that will remold or where injection causes build up of pore water pressures

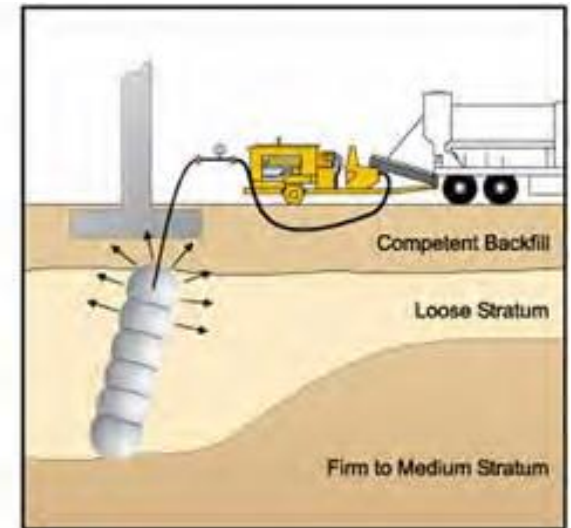
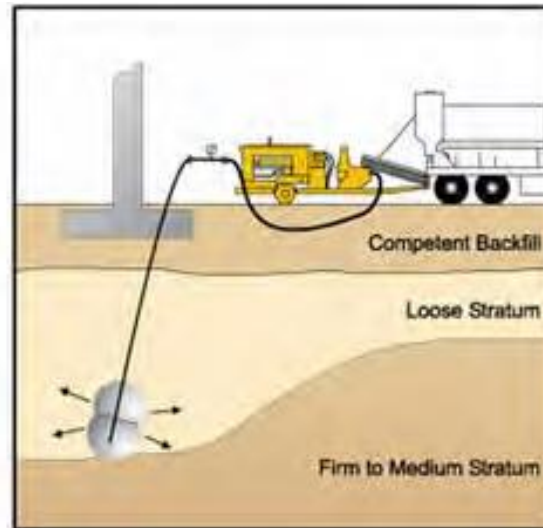
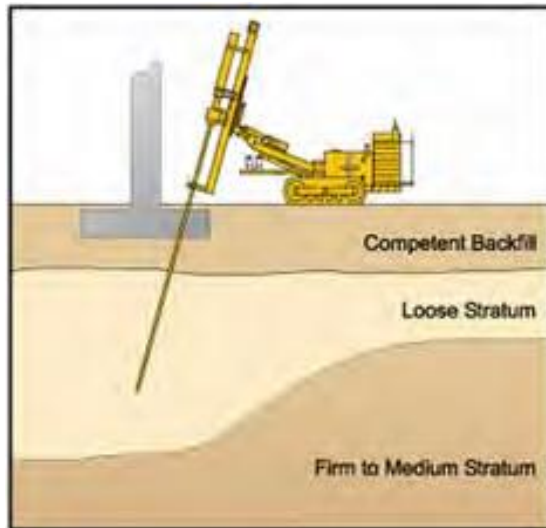

Compaction Grouting-Considerations

- Effective in loose granular soils, loose unsaturated fine-grained soils, collapsible soils and void filling
- Grout must have high internal friction, to ensure bulbs preserve “spheroidal” shape in the soil
- Less than 2-inch slump
- Greater than 3,000 psi compressive strength

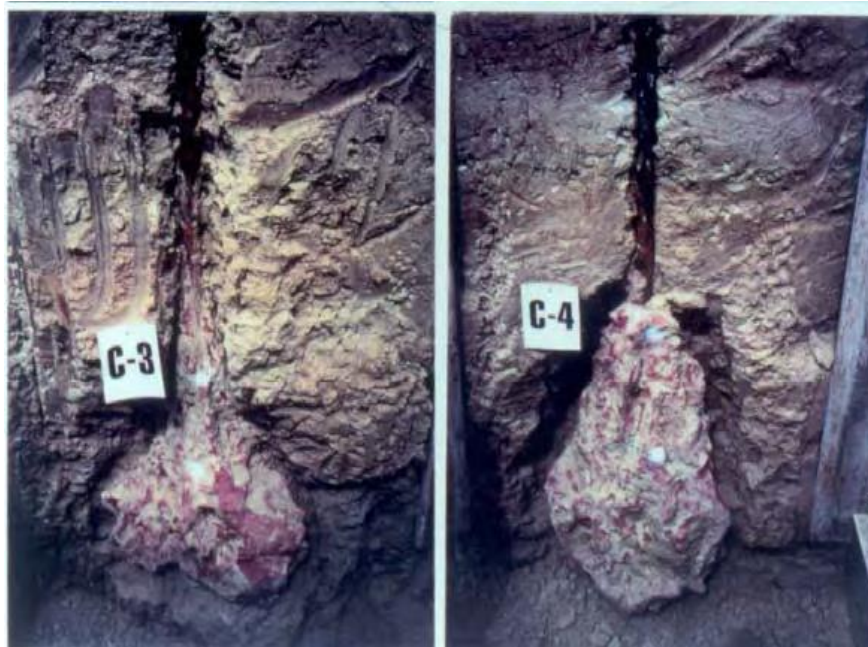

- The process of creating soil-cement in place with a stabilizing grout mix delivered at pressure through nozzle(s) at the end of a monitor inserted in a borehole. The soil-cement is created by lifting and rotating the monitor defined above at slow, smooth, constant speeds, cutting and mixing the soil with grout and air.



Jet Grouting

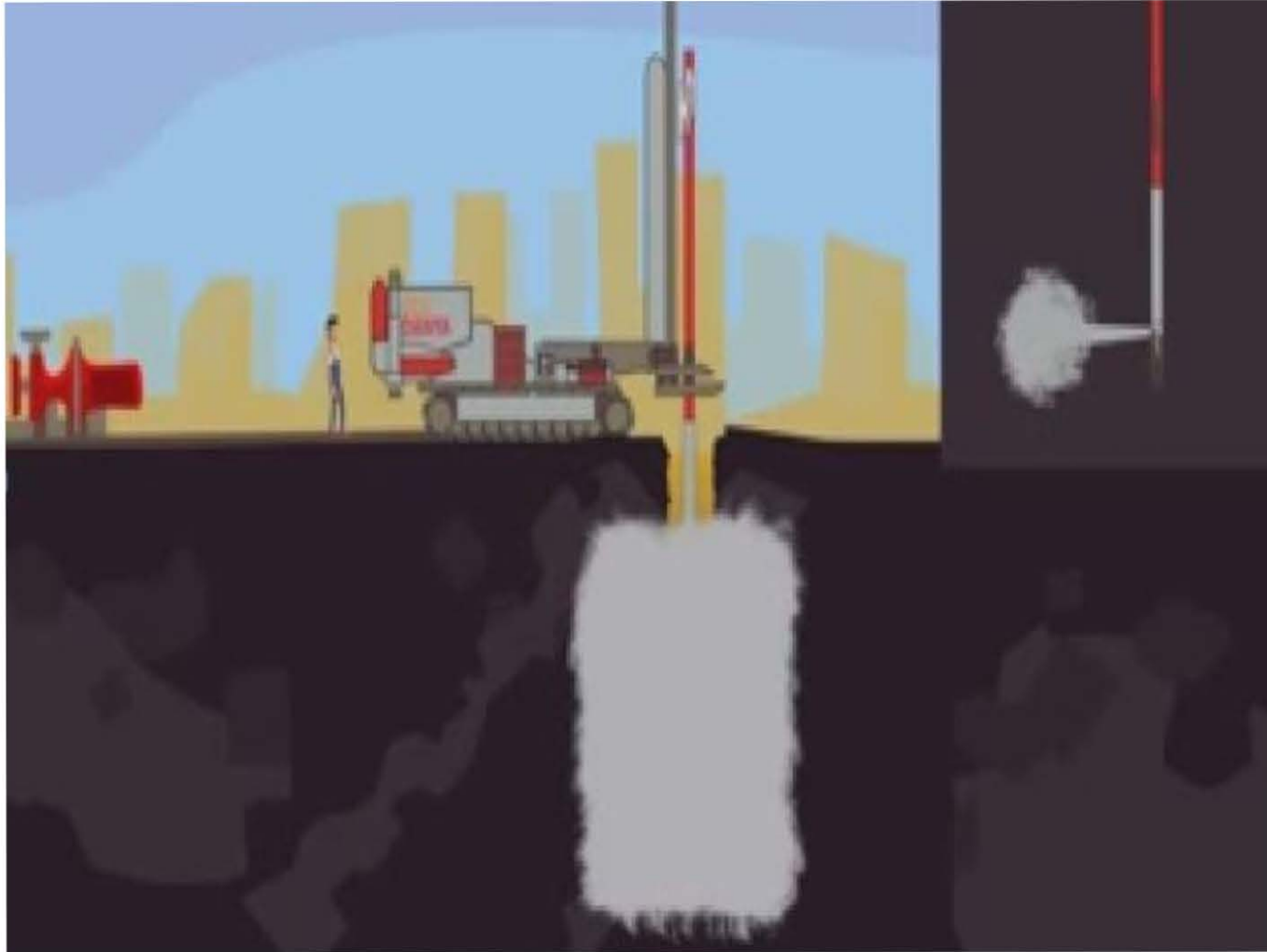





- Erosion-improve wide range soils
- Geometry-treat selected depth interval
- Equipment-flexible / mobile track rigs
- Groundwater -effective above & below GWT
- Properties-continuous cemented soil mass

Questions ?

Dr. Malek Smadi, P.E.

Principal Engineer - GEOTILL - Fishers, Indiana

msmadi@geotill.com - www.geotill.com