

Field Evaluation of Red Light Running Evaluation Methods



Steven Lavrenz, Darcy Bullock
Purdue University

101st Annual Purdue Road School
Wednesday, March 11th, 2015



PURDUE
UNIVERSITY

Existing Red Light Running Research

- Countermeasure effectiveness vs. site selection
- Bonneson (2003): Video detection & automated camera enforcement to track red light runners
- Papaioannou (2007), Sharma et al. (2007), Lavrenz et al. (2014): Factors influencing driver behavior in dilemma zones
- Lu et al. (2015): Yellow Light Running Identification with Loop Detectors

Factors Behind Red Light Runners (RLRs)

Dilemma Zones

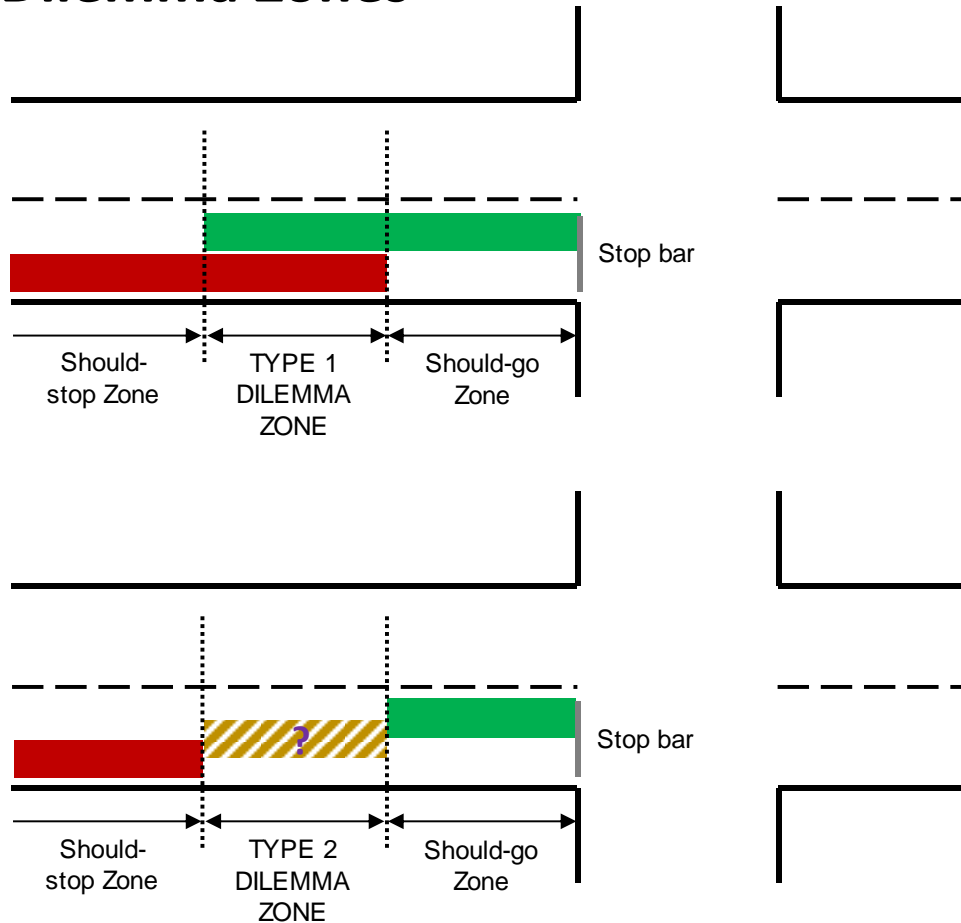

Distracted Driving

Split Failures & Other Congestion



Conceptual Overview





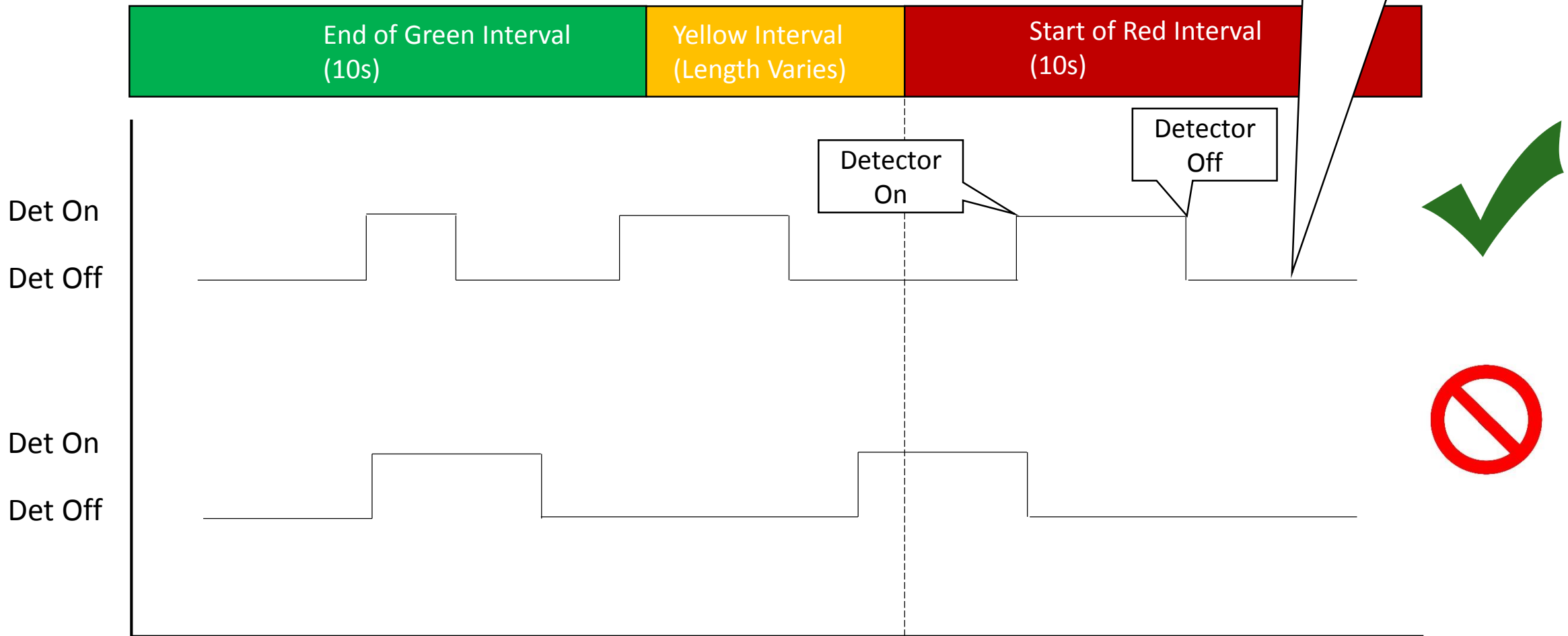

Field Evaluation of Red Light Running Evaluation Methods

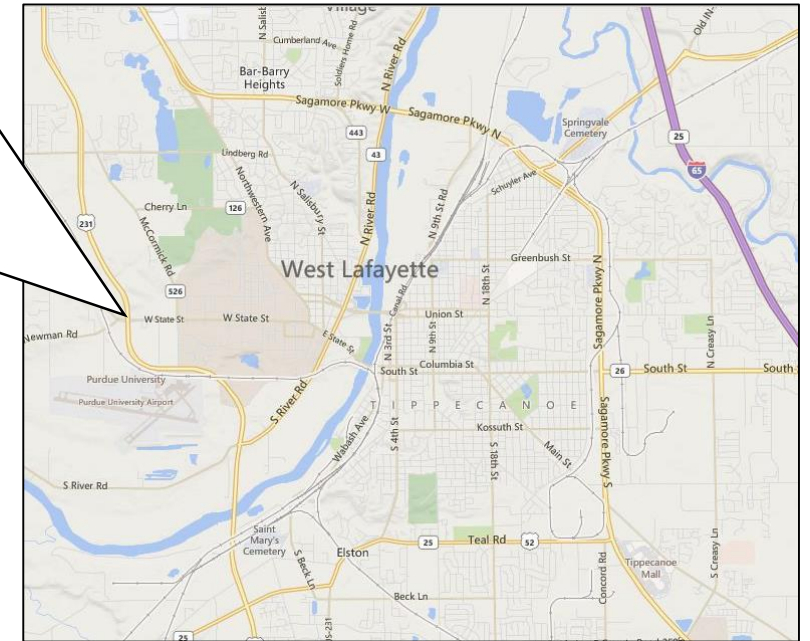
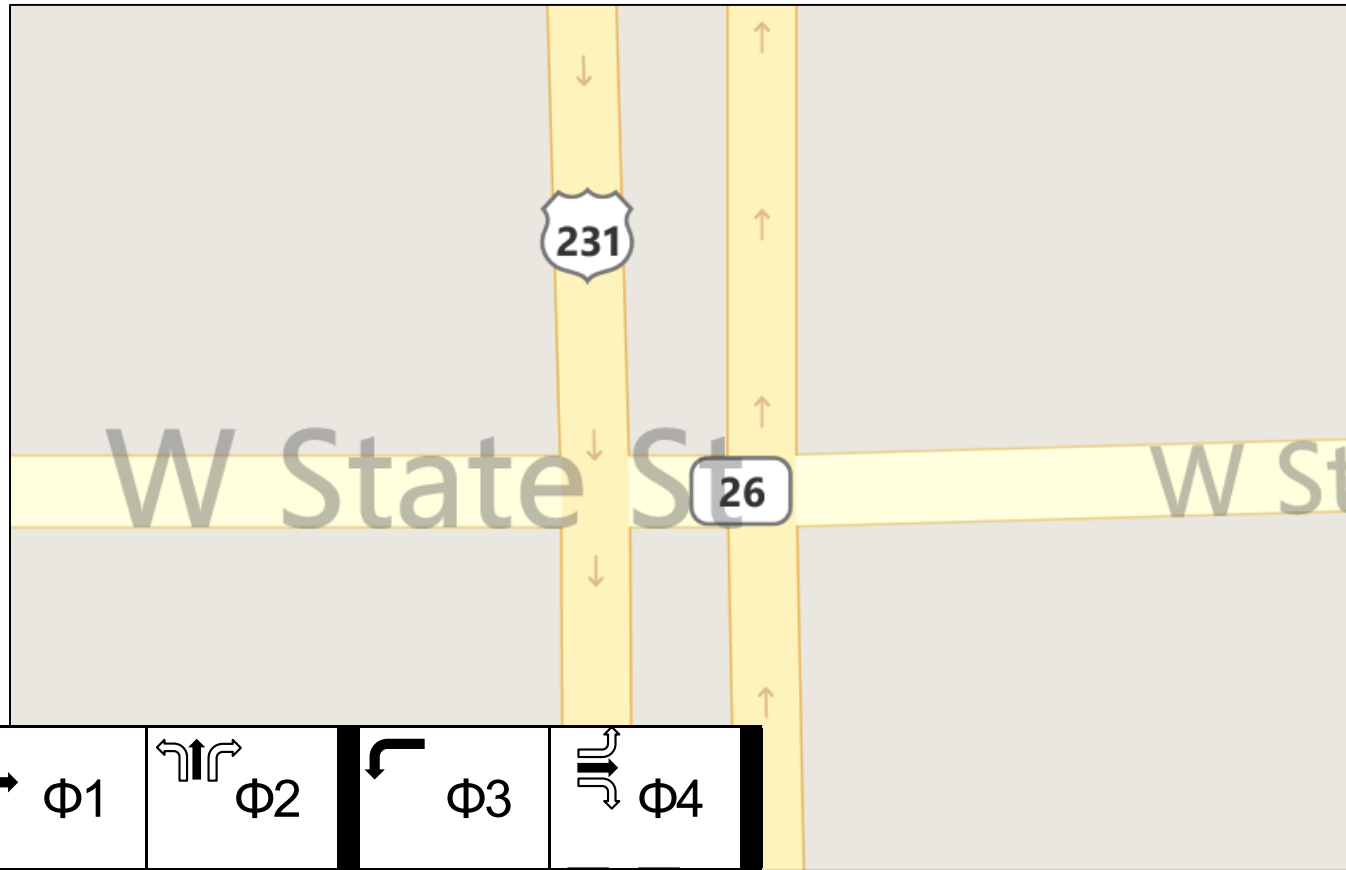
Concept: How is a Red Light Runner Defined?

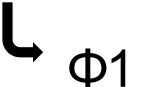
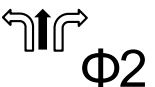

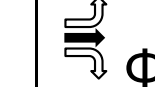
Conceptual Example: US231 & State St.

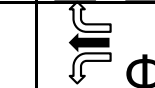

 $\Phi 1$	 $\Phi 2$	 $\Phi 3$	 $\Phi 4$
 $\Phi 5$	 $\Phi 6$	 $\Phi 7$	 $\Phi 8$

Conceptual Example: US231 & State St.

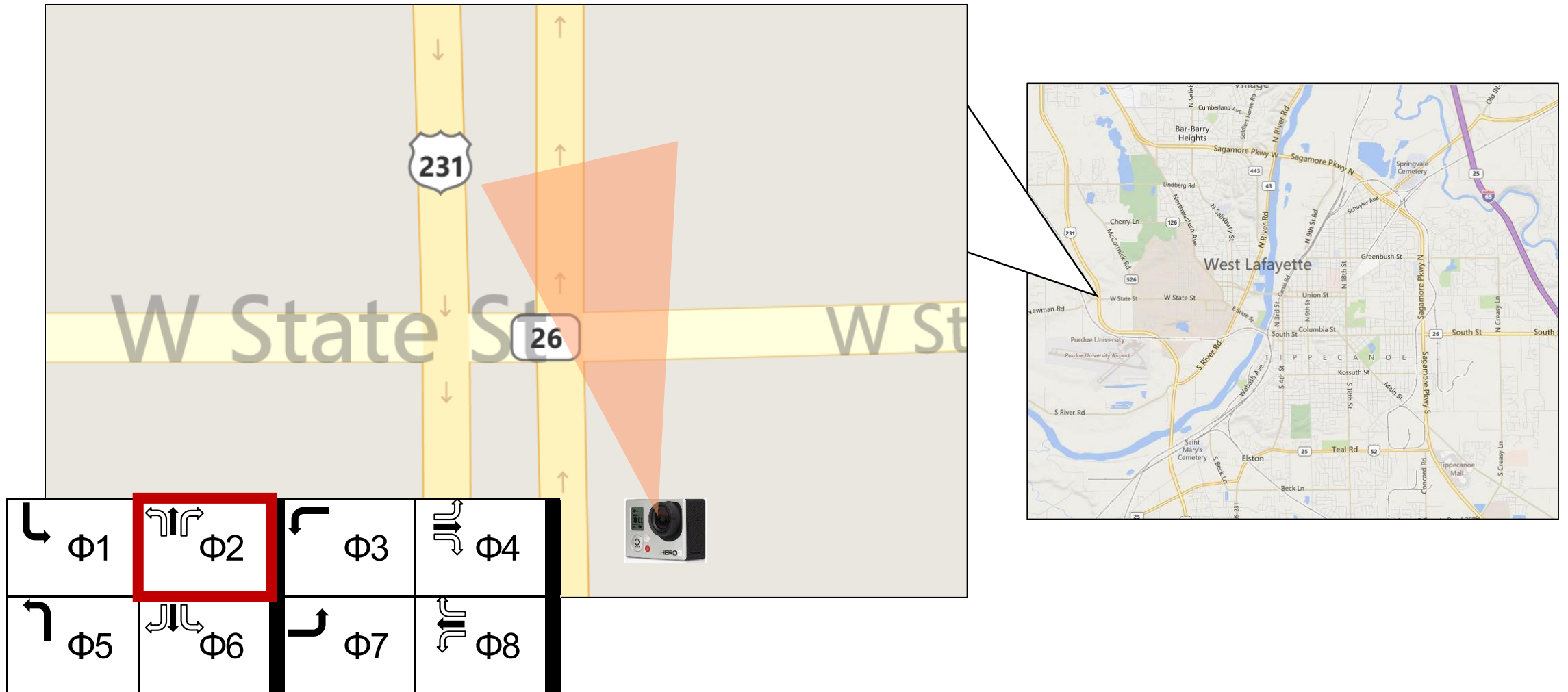

Field mounting of cameras for video recording

US231 & State St



US231 & River Rd





DET
ON

DET
OFF

16:40:25

16:40:30

16:40:35

16:40:40

16:40:45

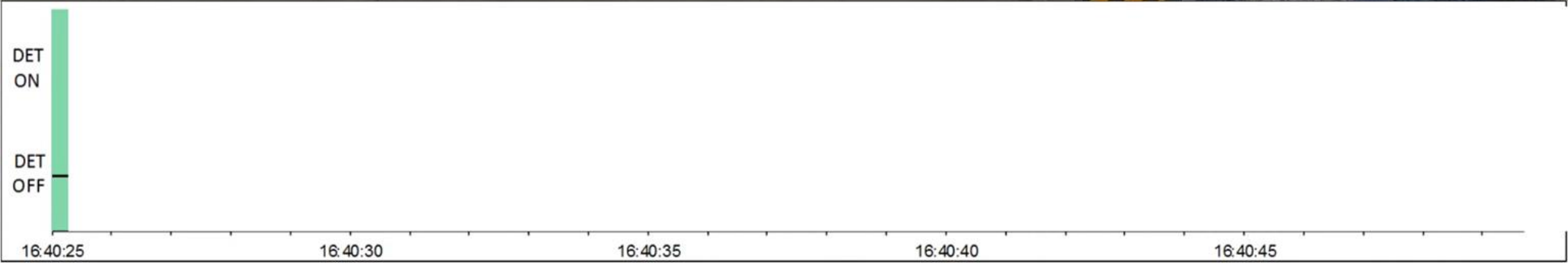

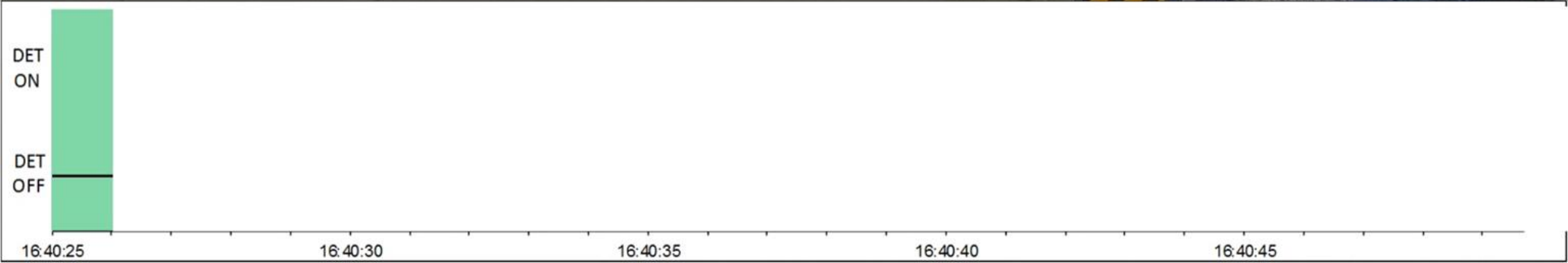

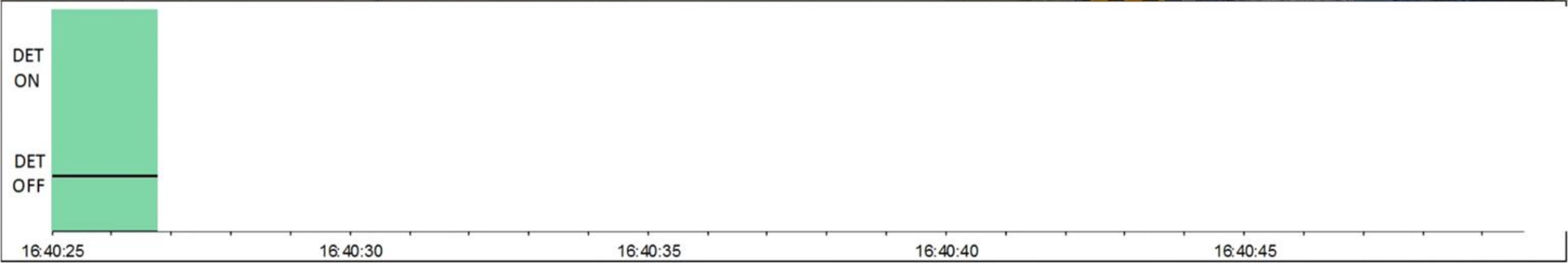

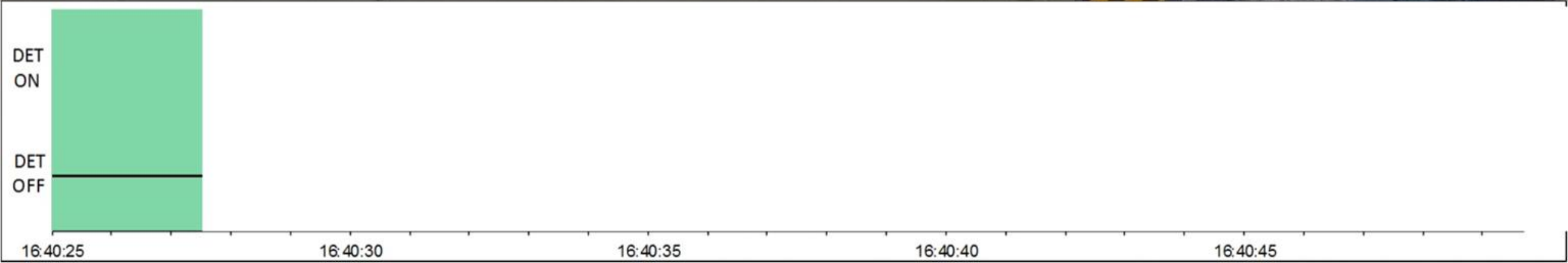

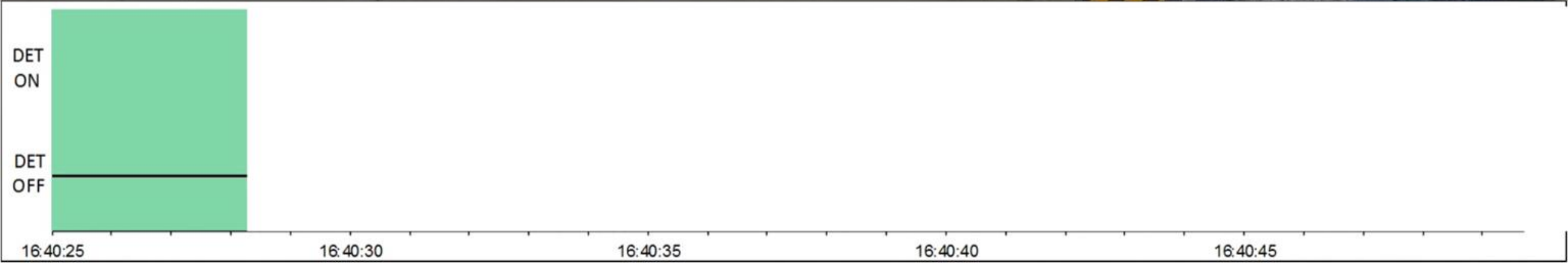

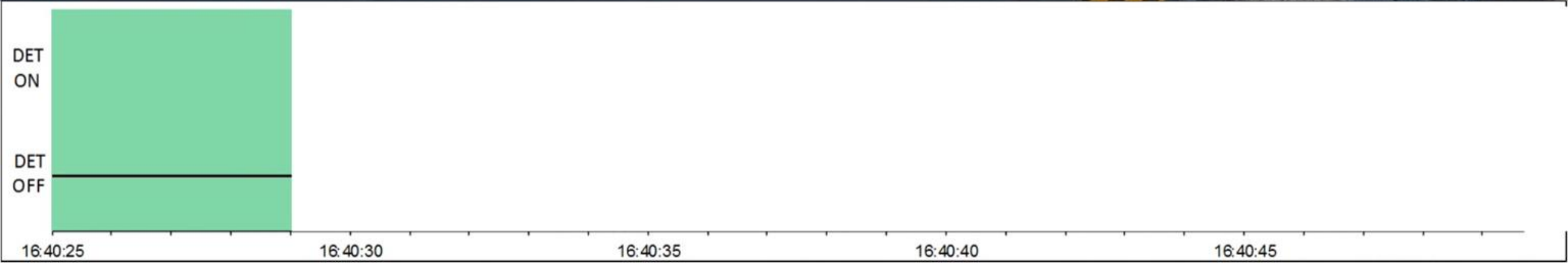



Detector Zone
Occupied

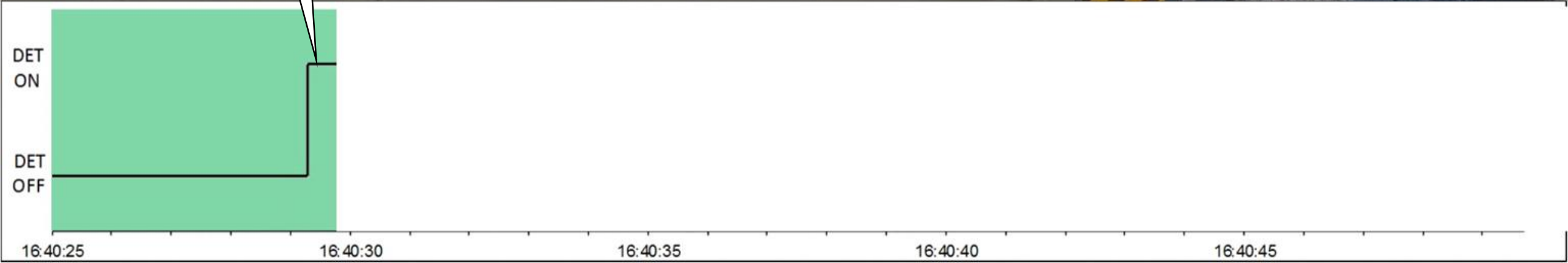

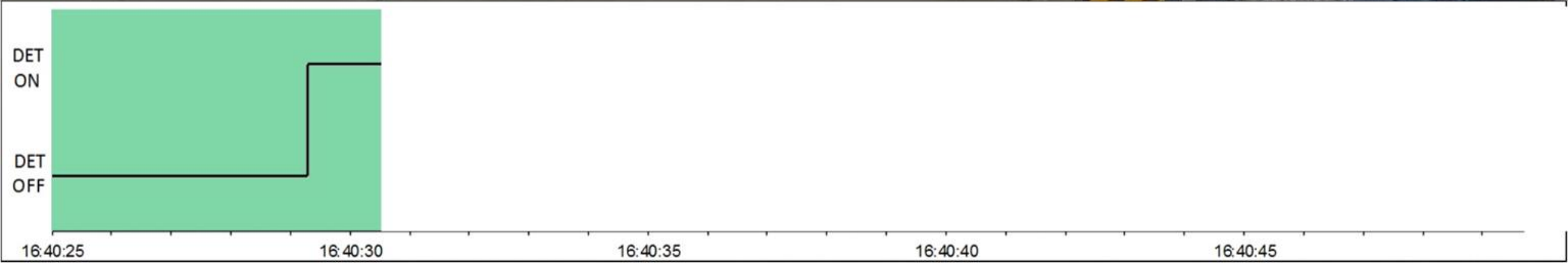



Detector Zone
Unoccupied

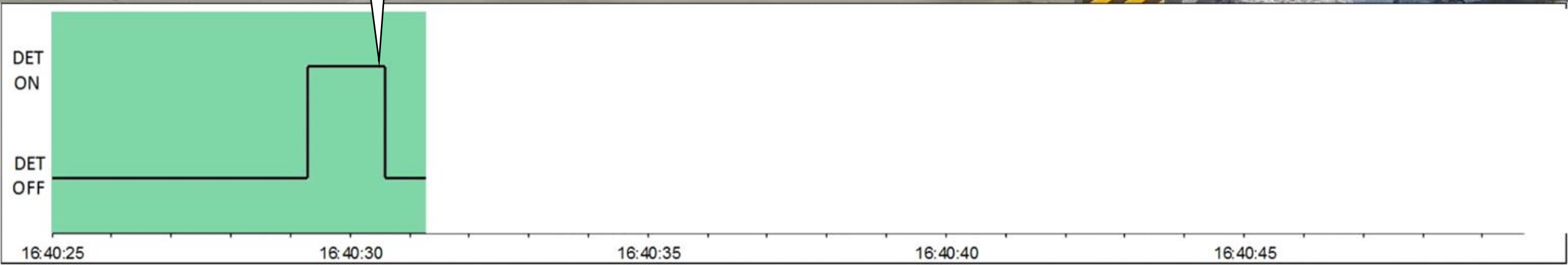

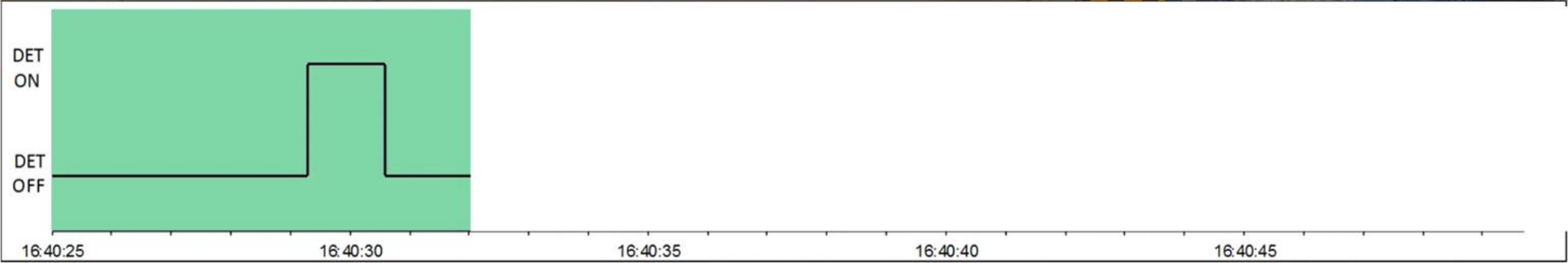

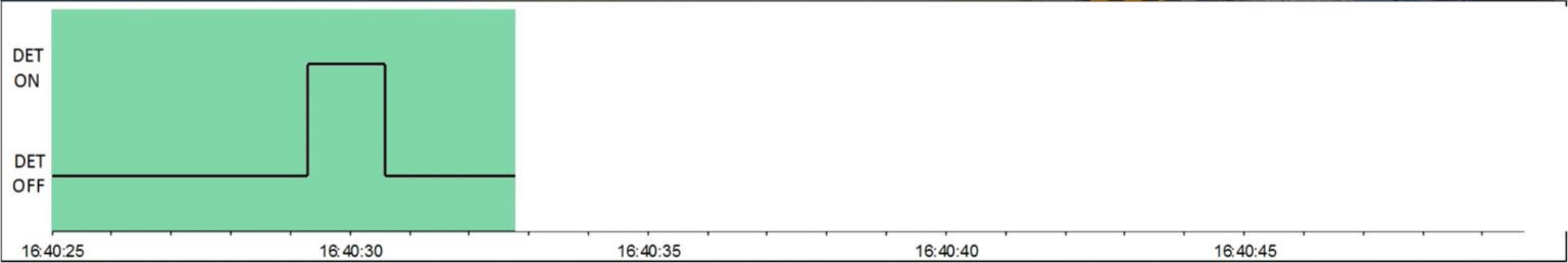

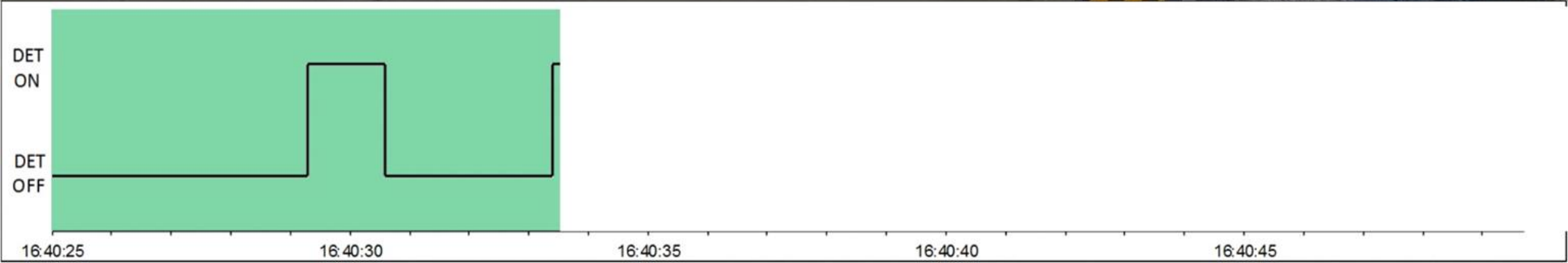

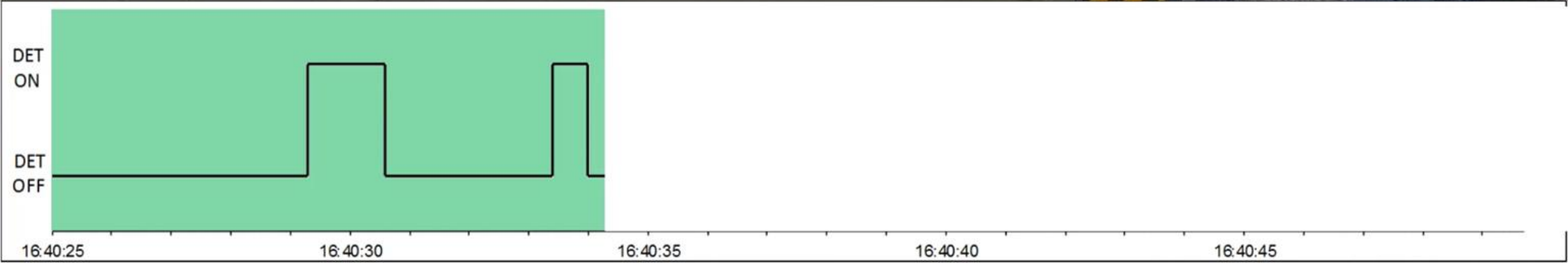

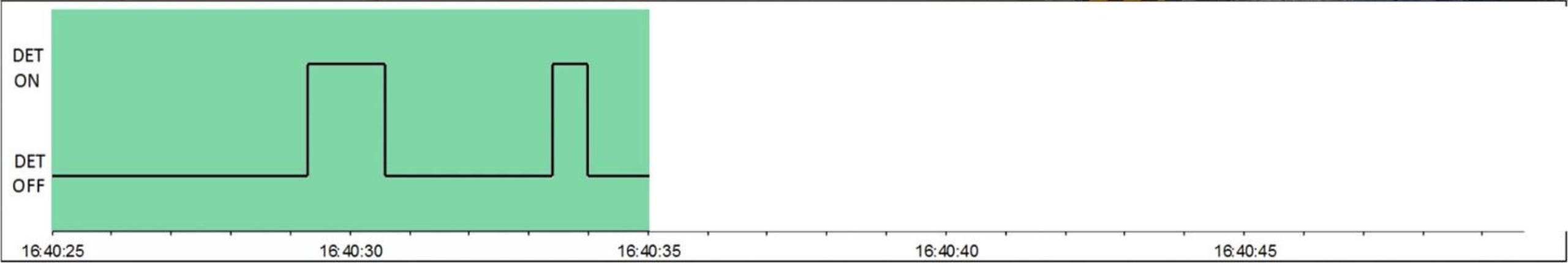



Start of Yellow

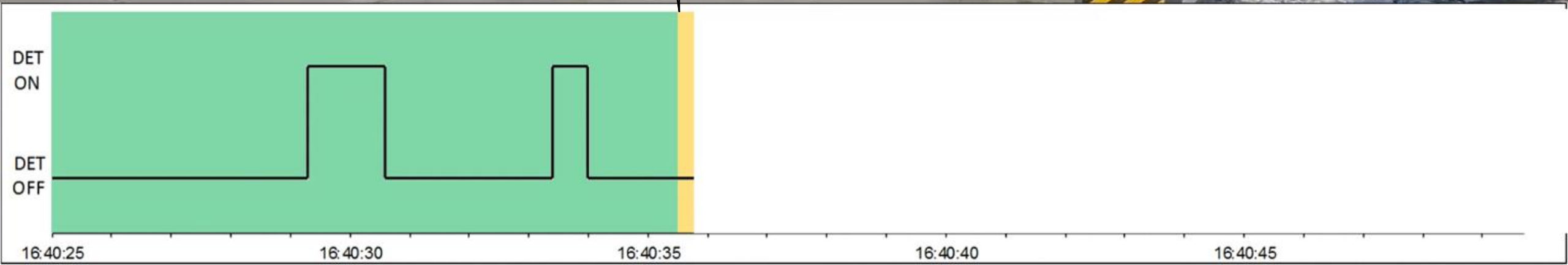

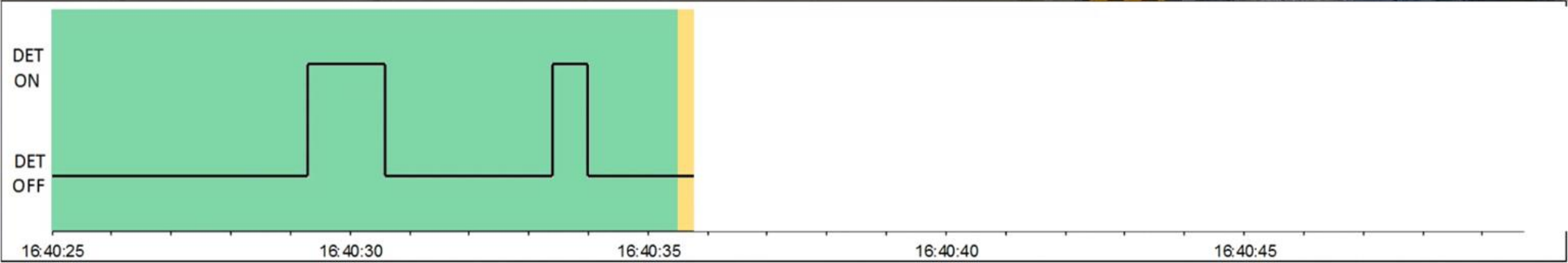

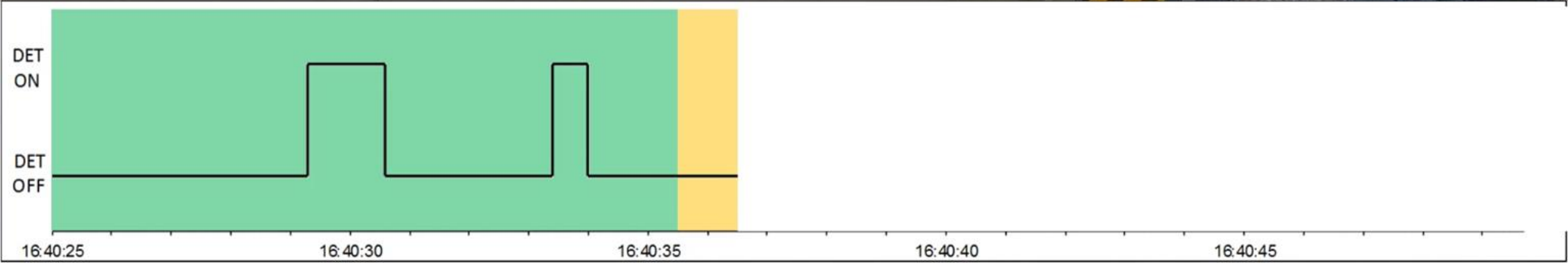

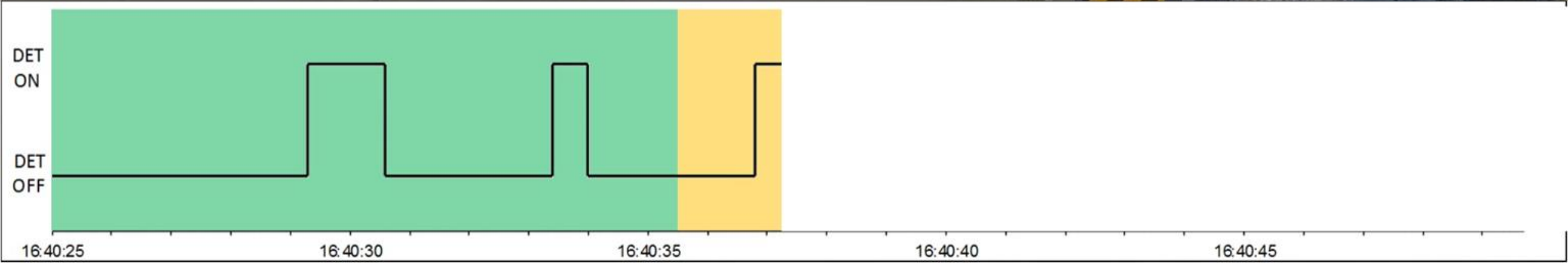
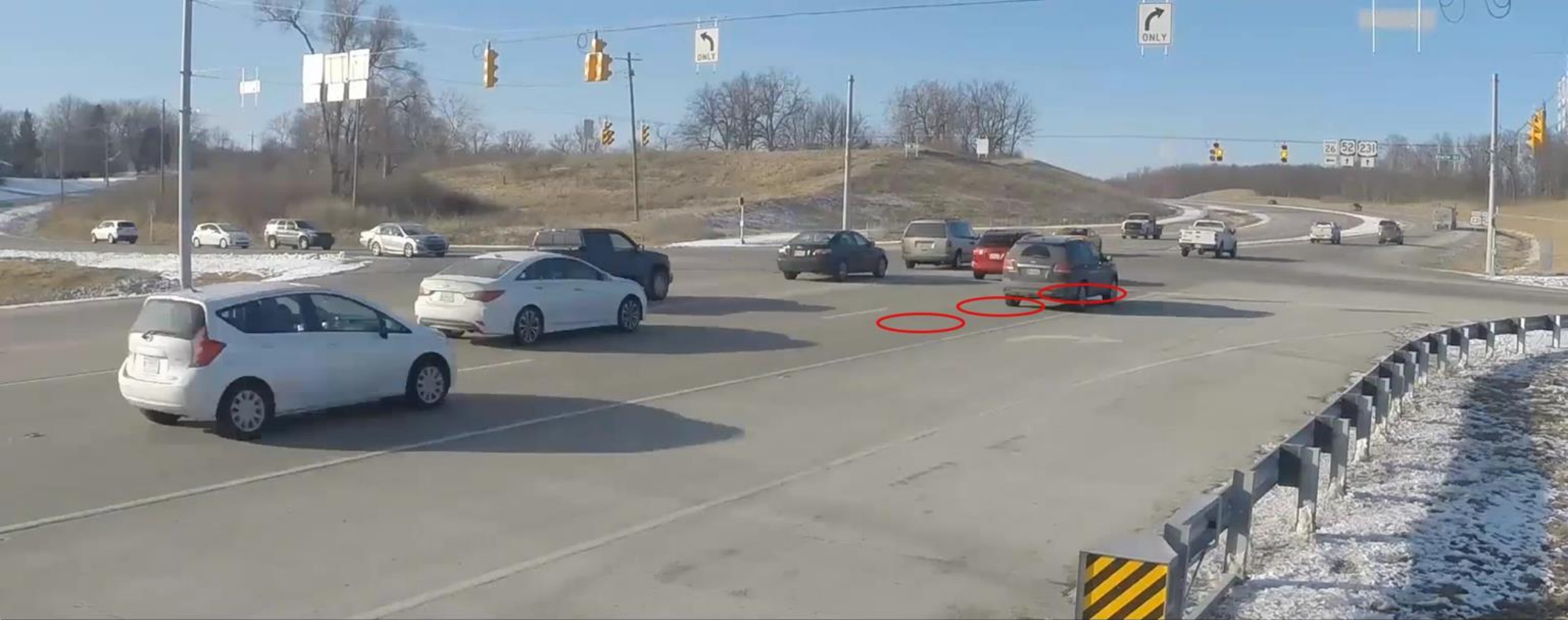

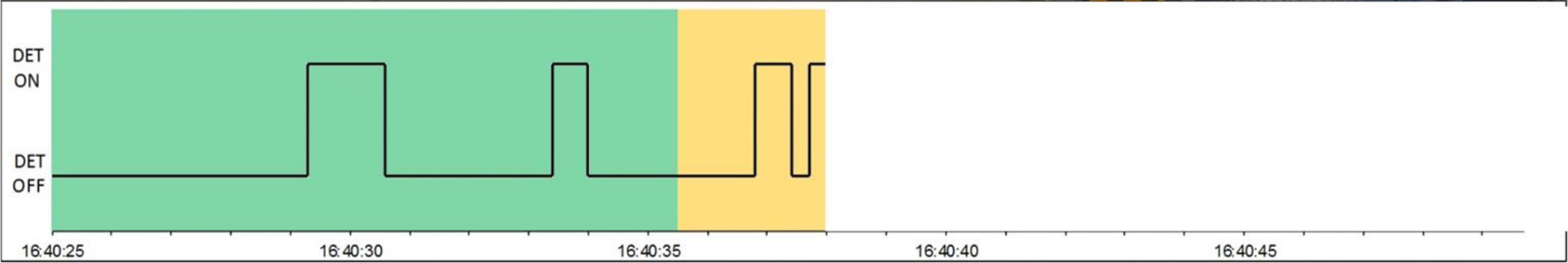

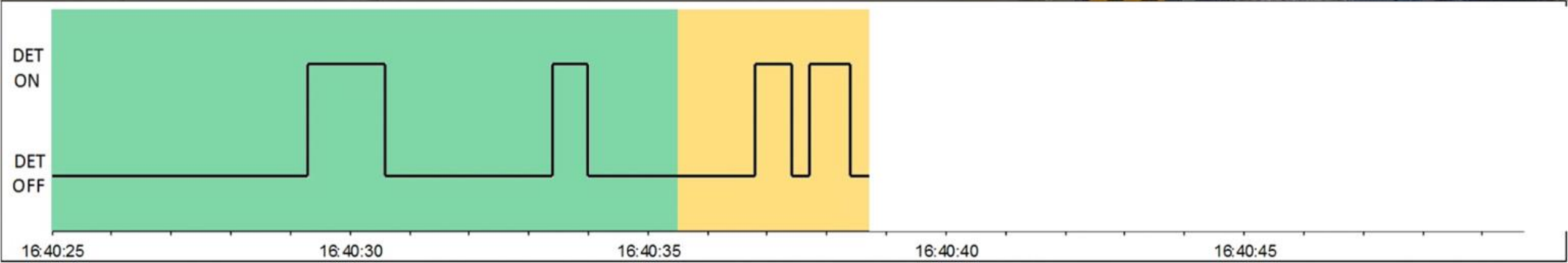

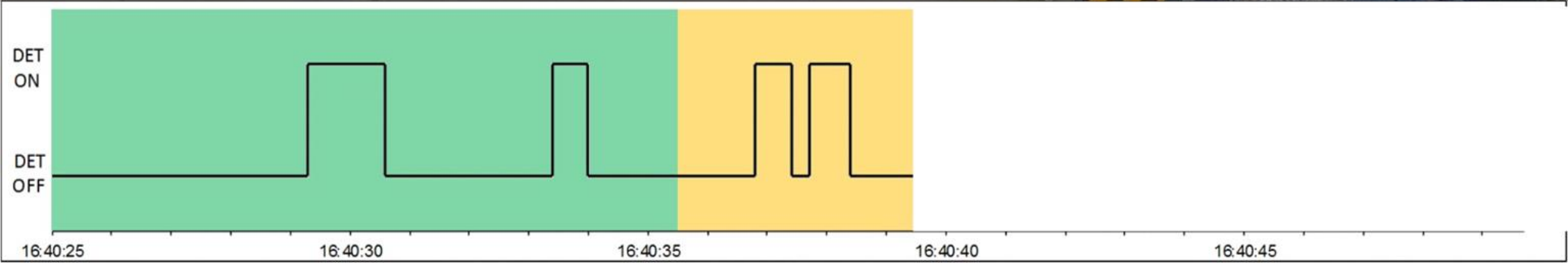

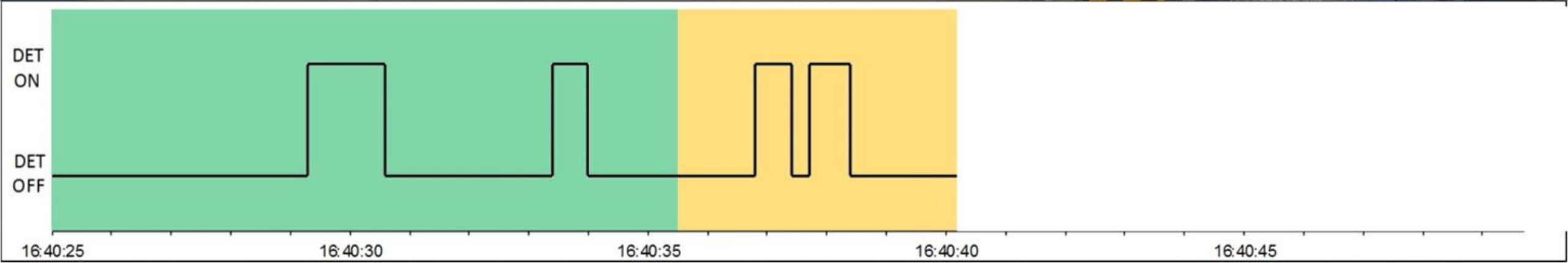

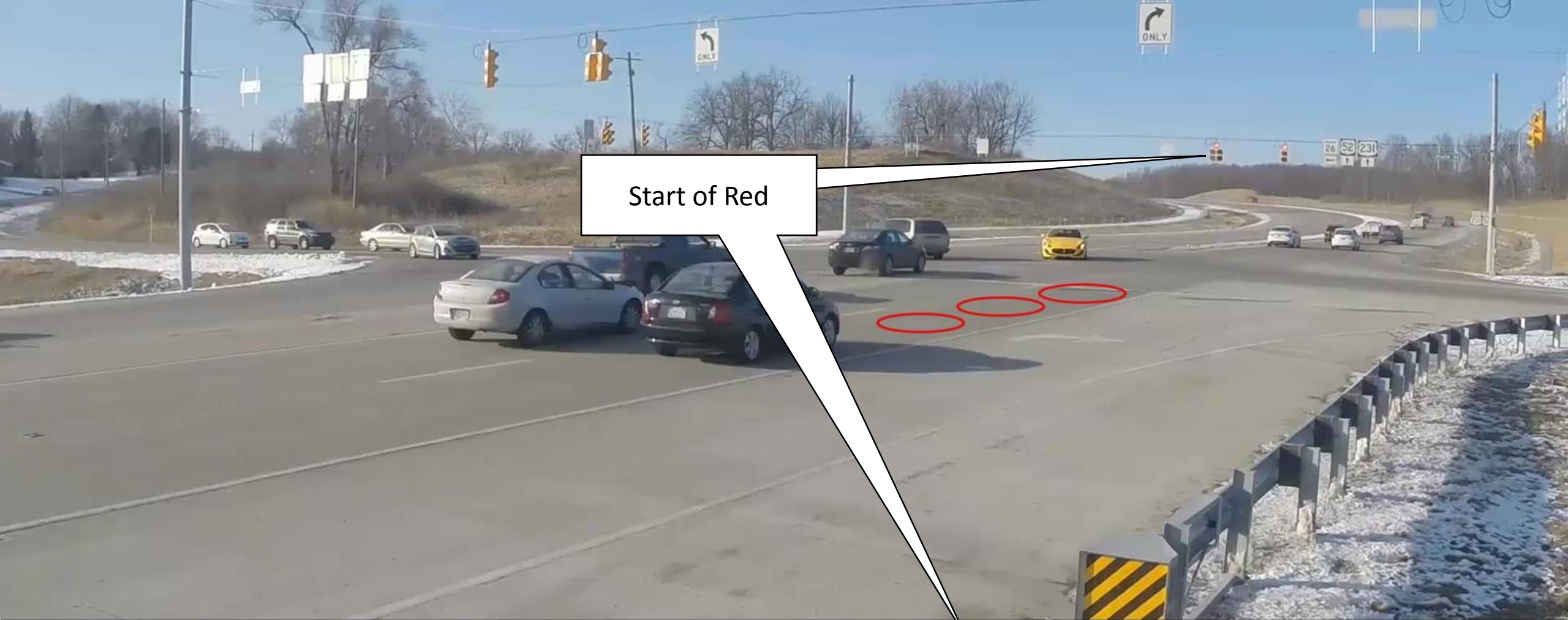

Start of Red

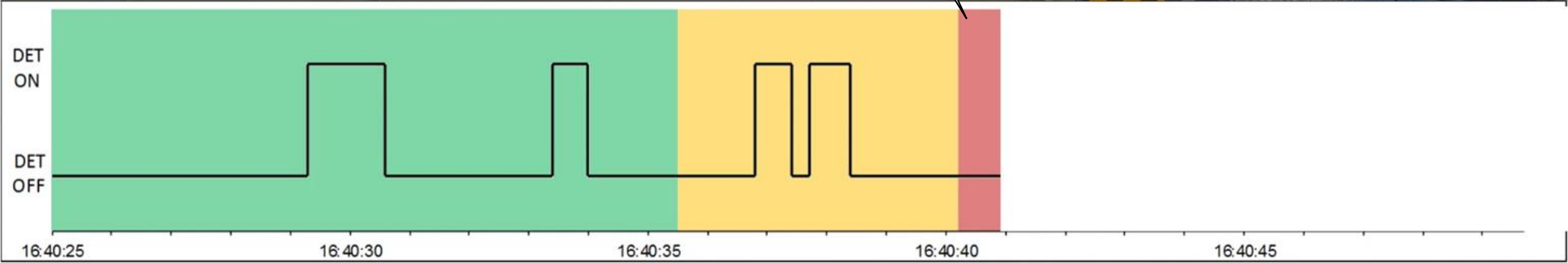

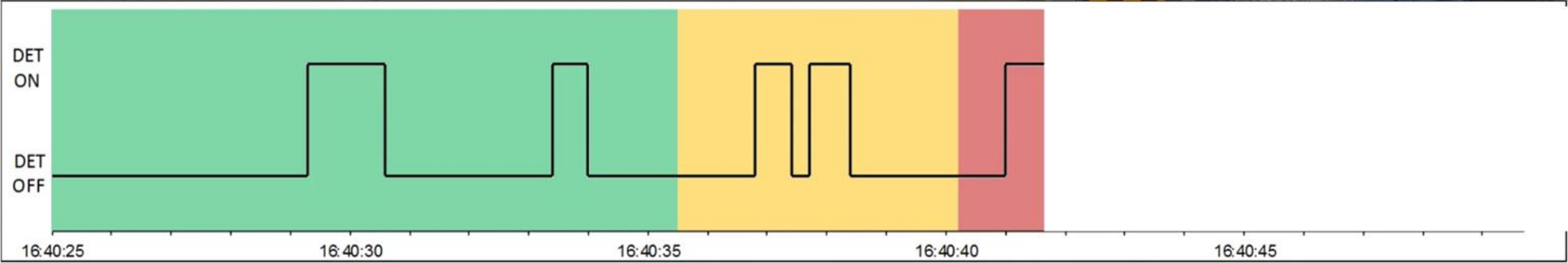

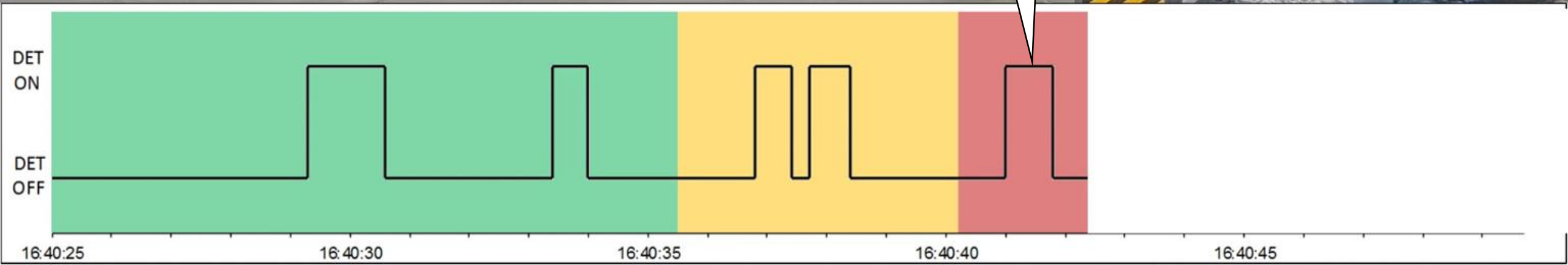

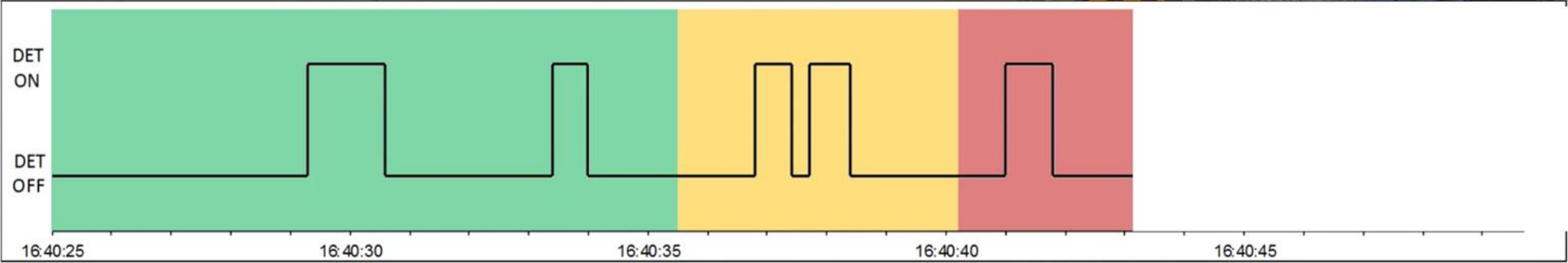

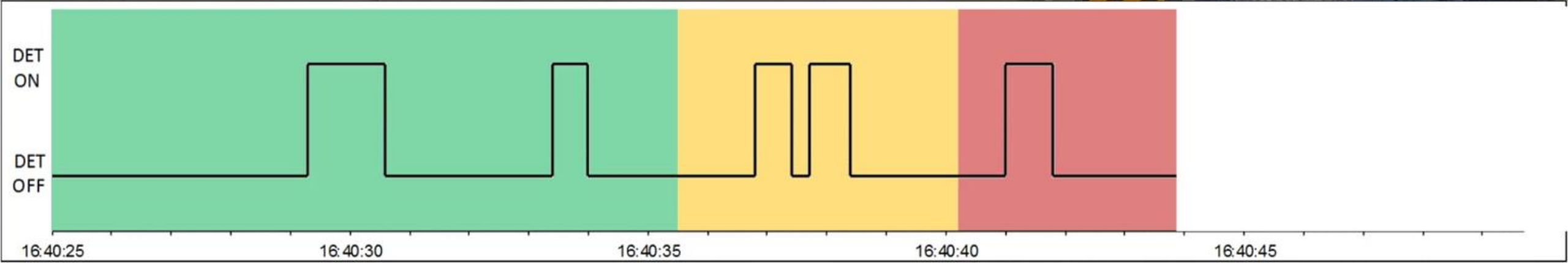

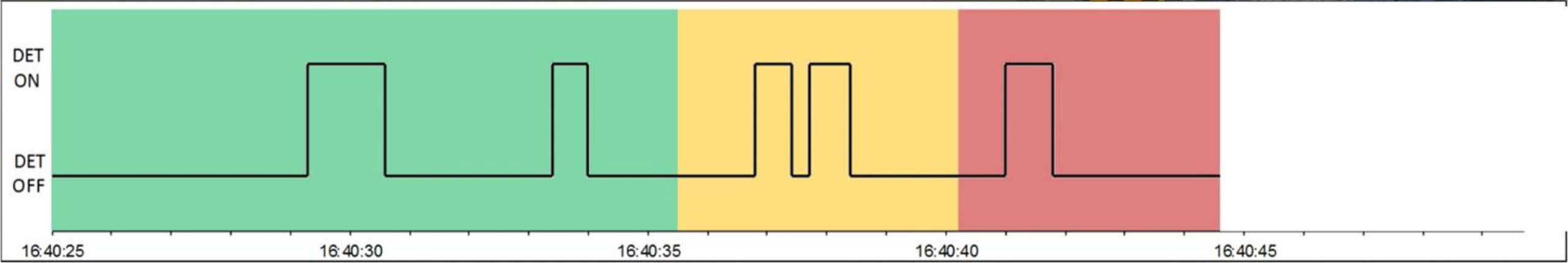

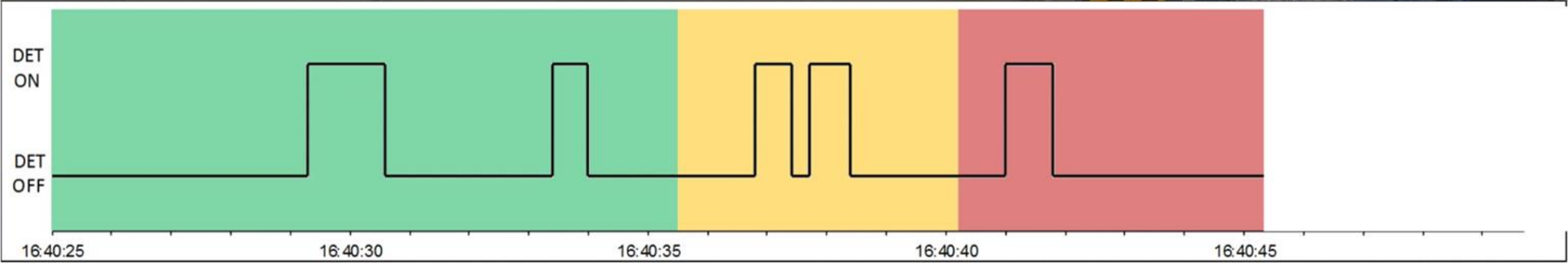

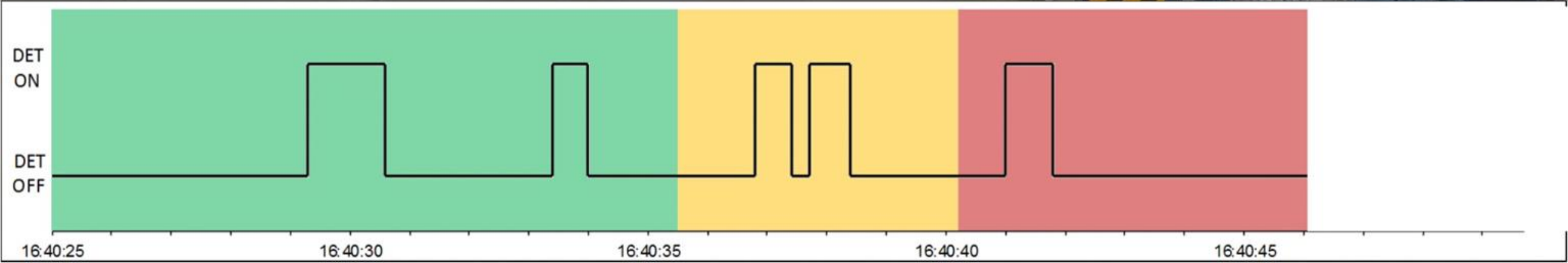

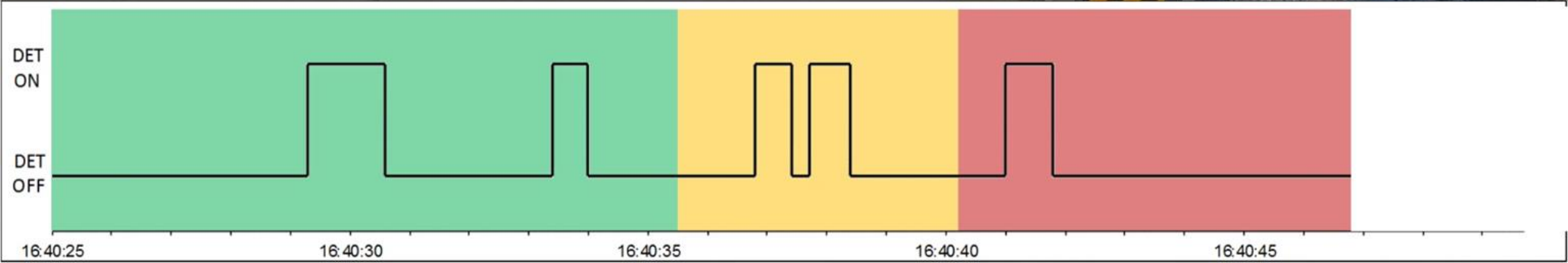

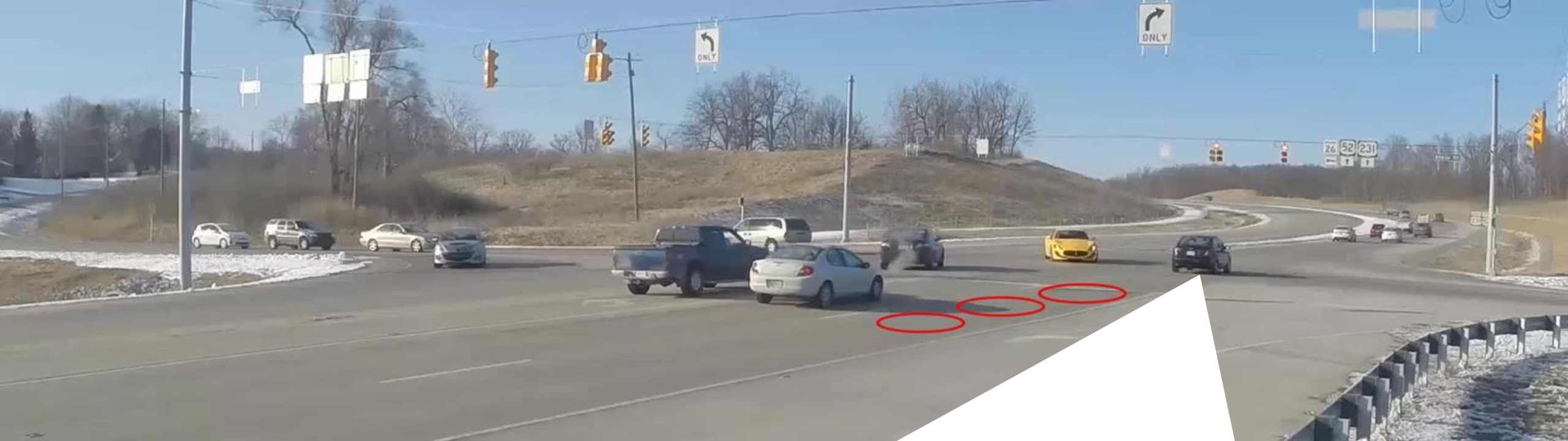

Estimating RLR Driver Speed through the Intersection

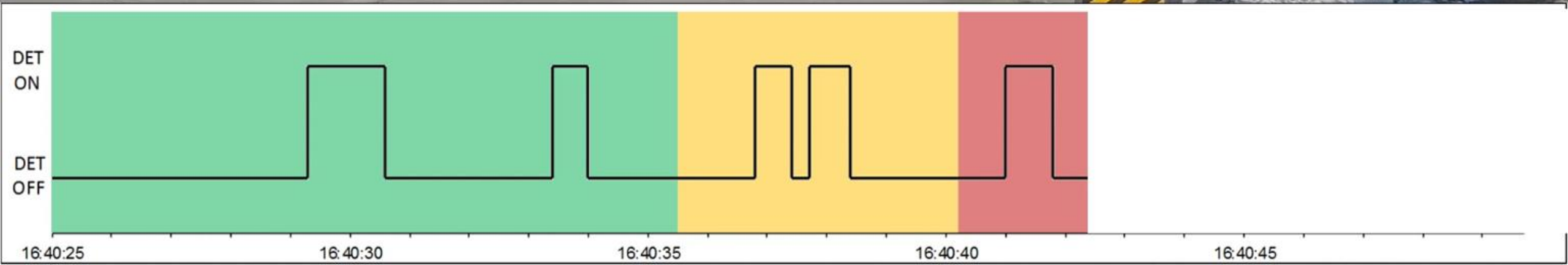

Estimating RLR Vehicle Speed through the Intersection

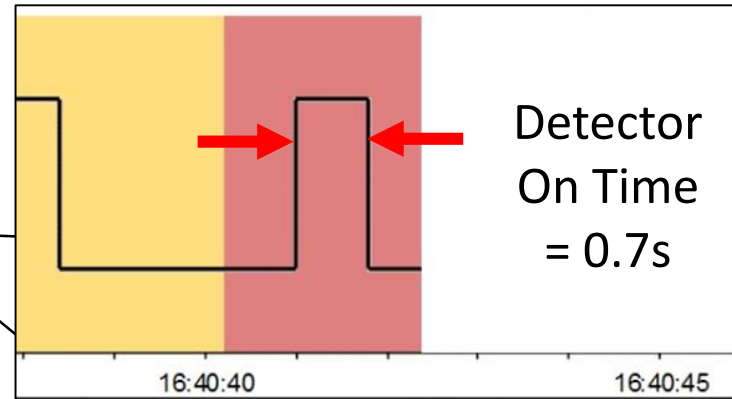
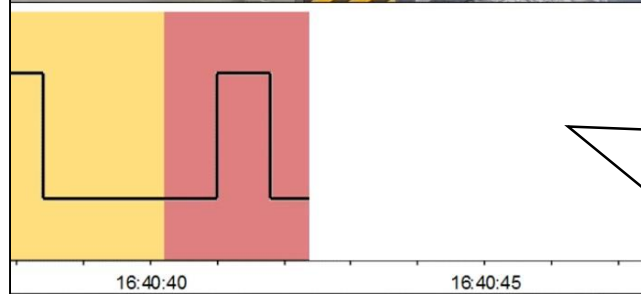
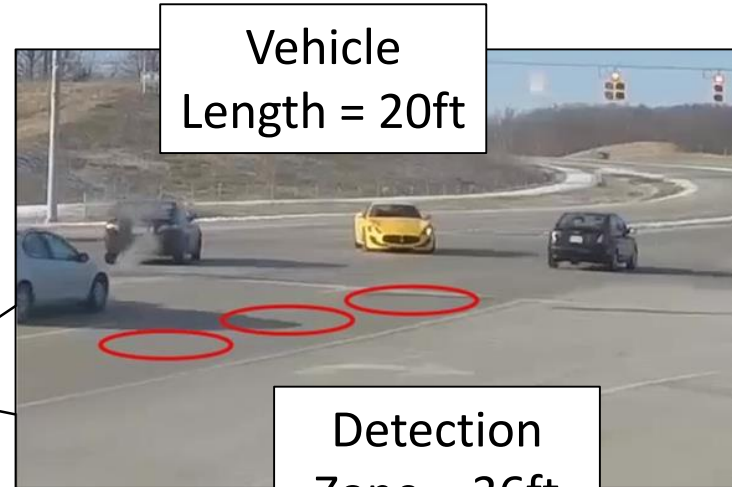

$$\begin{aligned} \text{RLR Vehicle Speed} &= \frac{\text{Distance}_{\text{Det On}}}{\text{Time}_{\text{Det On}}} \\ &= \frac{(20\text{ft} + 36\text{ft}) * \frac{1 \text{ mile}}{5,280\text{ft}}}{(0.7\text{s}) * \frac{1 \text{ hr}}{3,600\text{s}}} \\ &= \mathbf{54.5 \text{ mph}} \end{aligned}$$

US 231 & State St. Patterns & Trends

Field Evaluation of Red Light Running Evaluation Methods

Normalized RLR Distribution by Day of Week

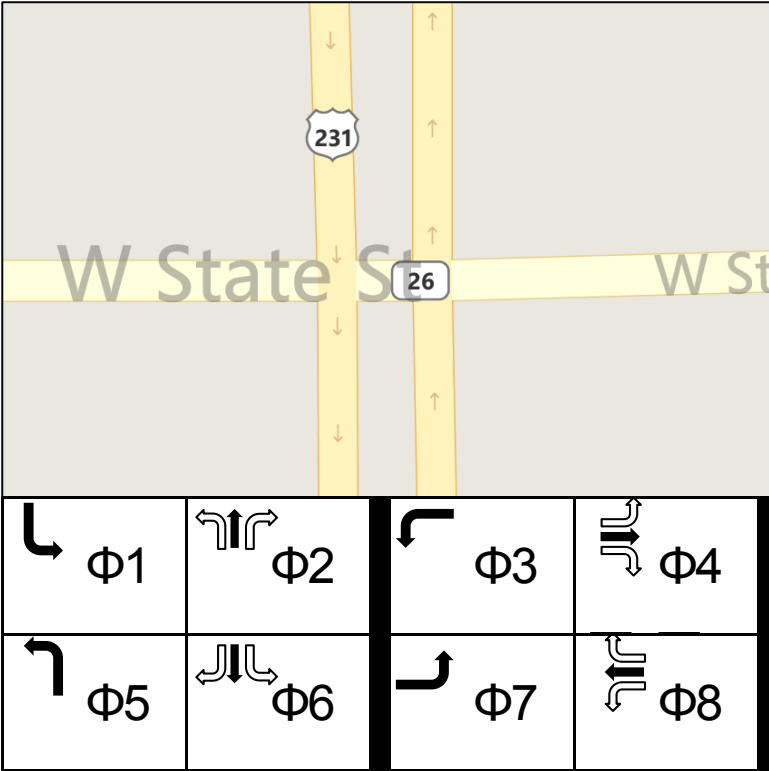
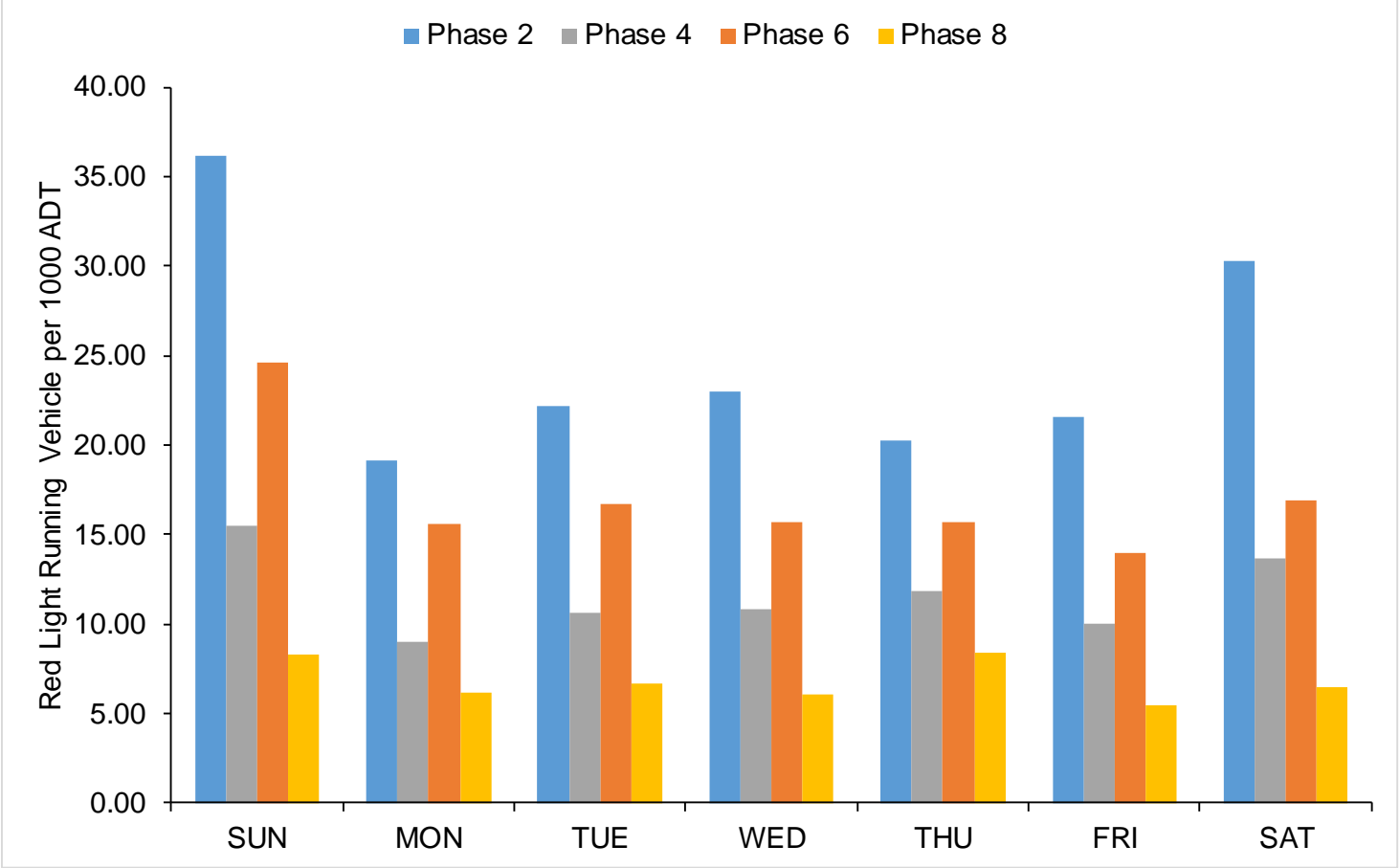

RLR Distribution by Hour of Day

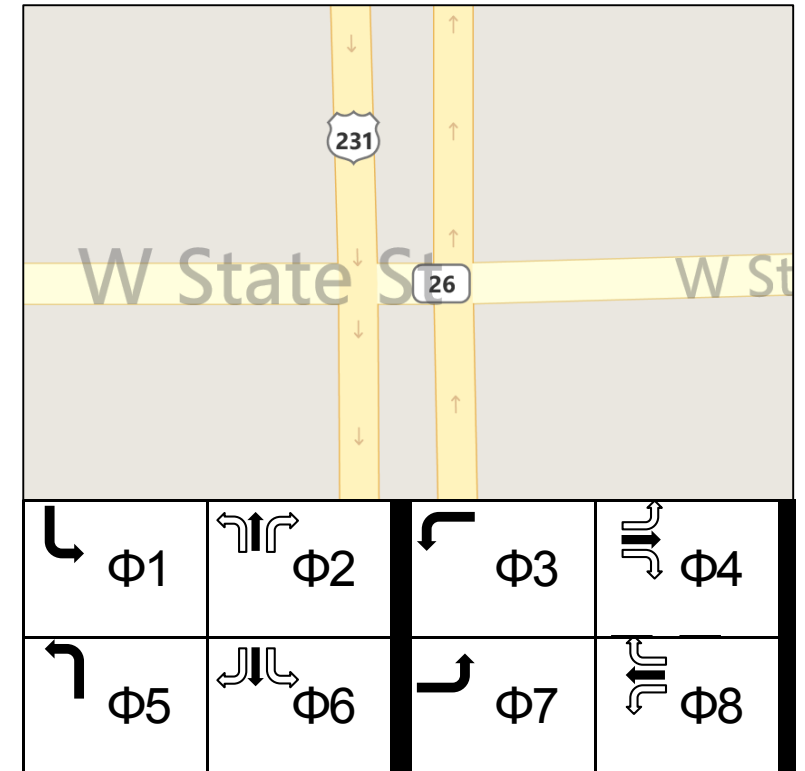
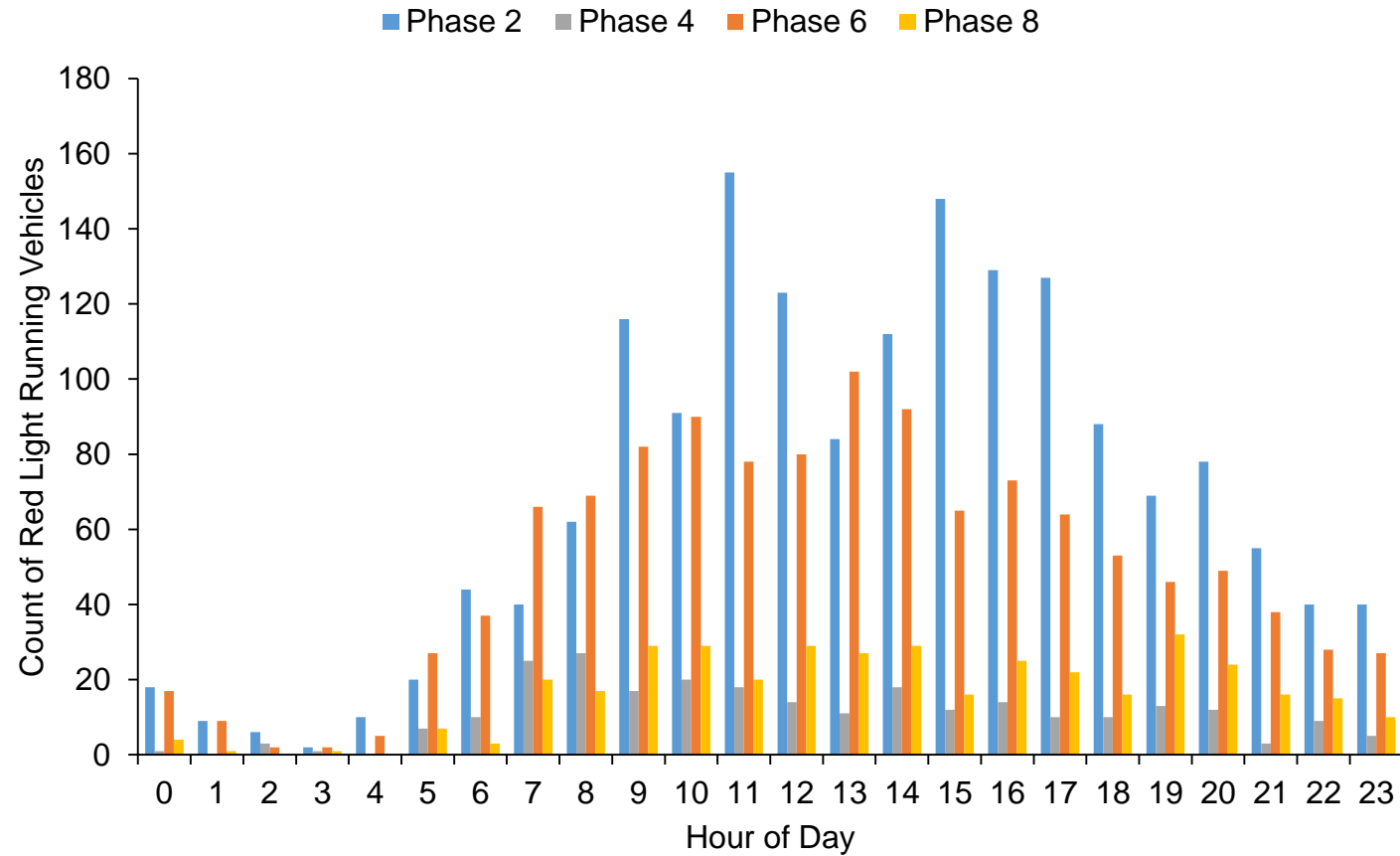

Normalized RLR Distribution by Hour of Day

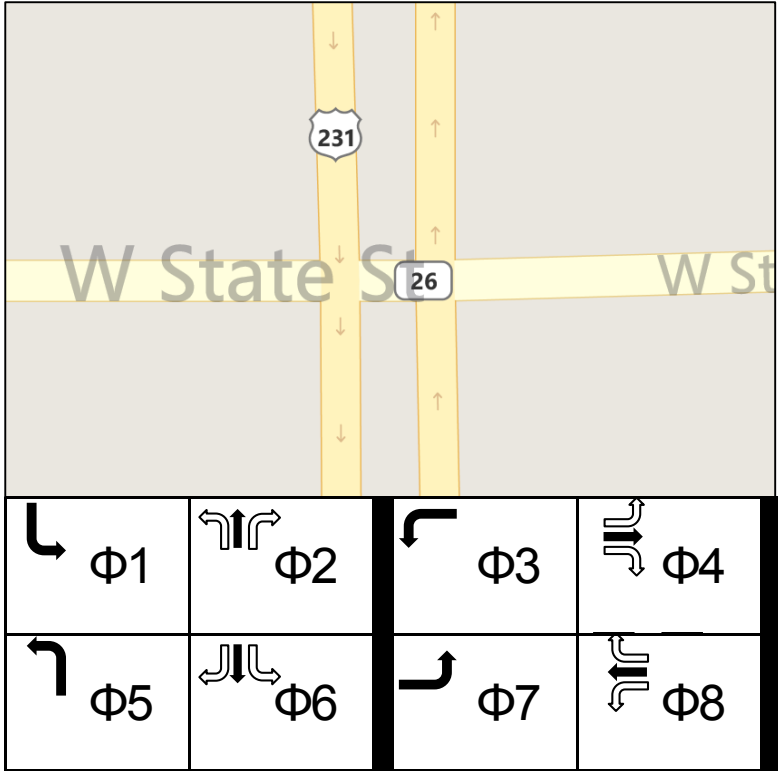
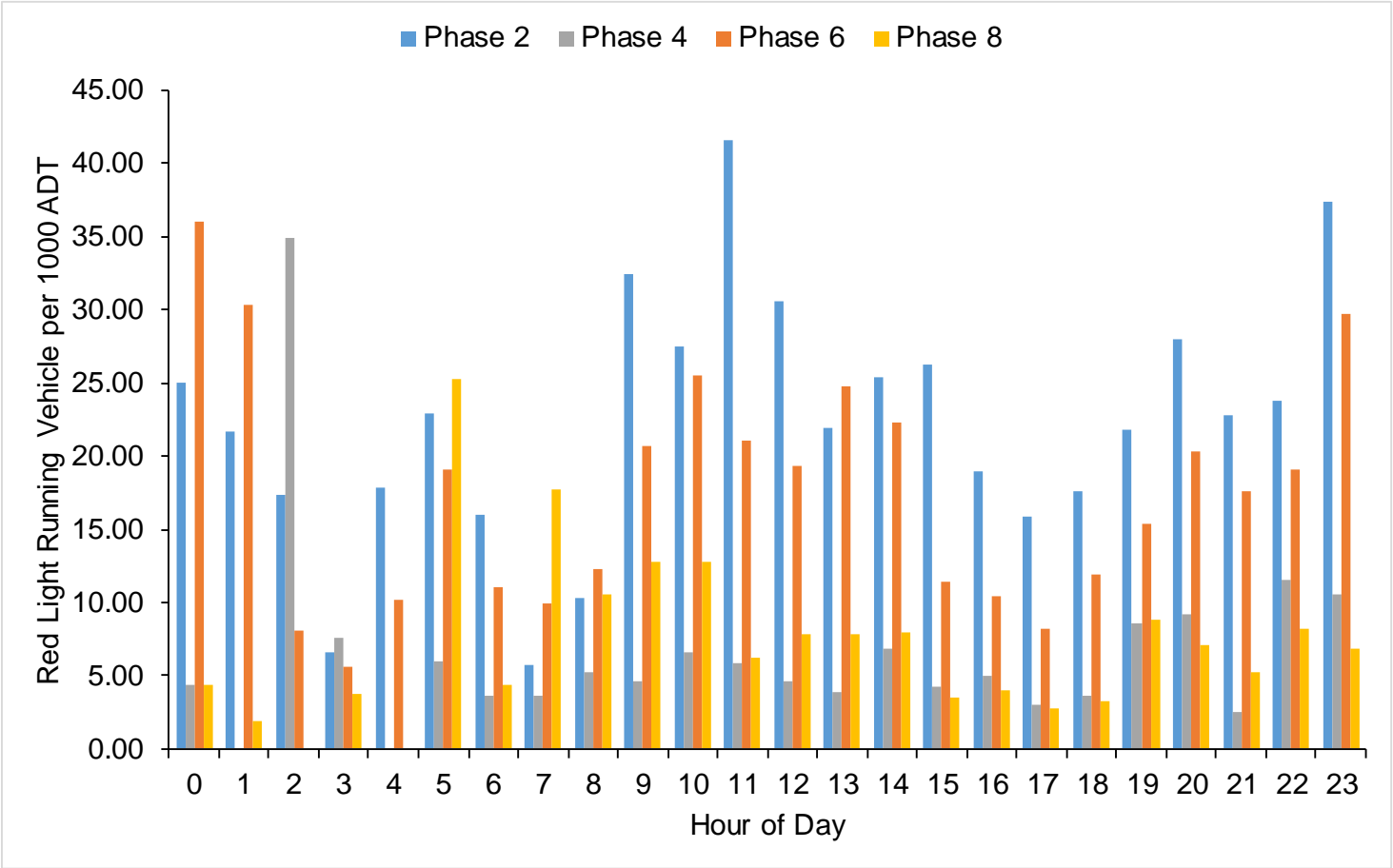

Normalized RLR Distribution by Timing Plan

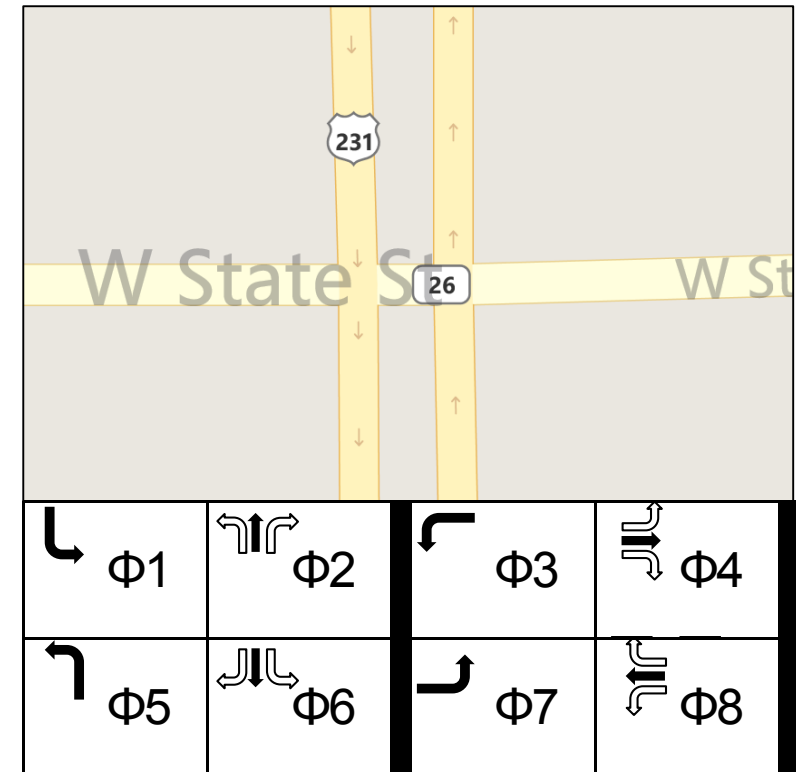
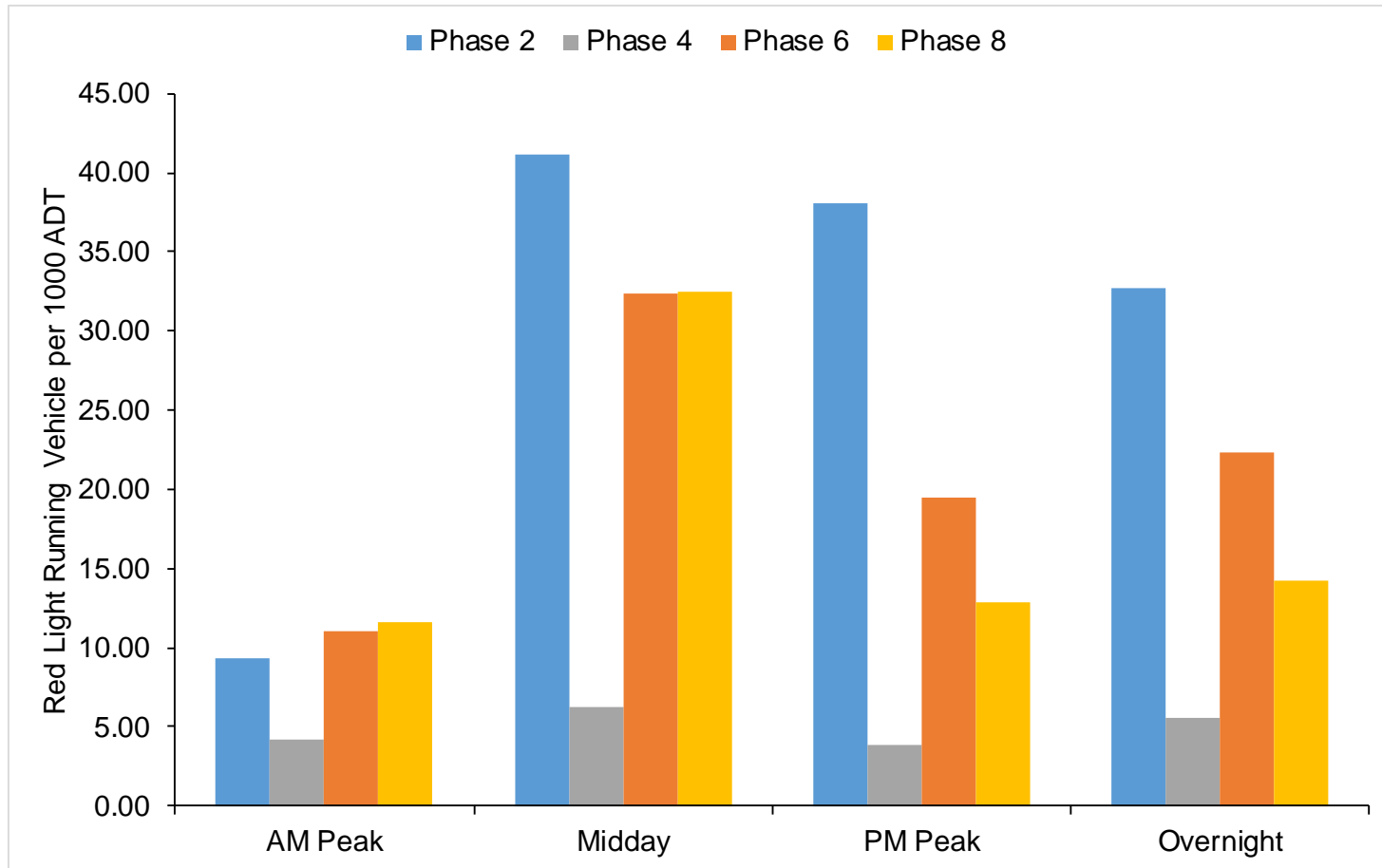

Benefits & Case Study Uses

Field Evaluation of Red Light Running Evaluation Methods

Statewide High Resolution Signal Ranking



- Approximately 140 signals in Indiana with hi-res data
- Opportunities for targeted law enforcement
- Safety countermeasure screening

Phase 2/6 Top 20 Intersections







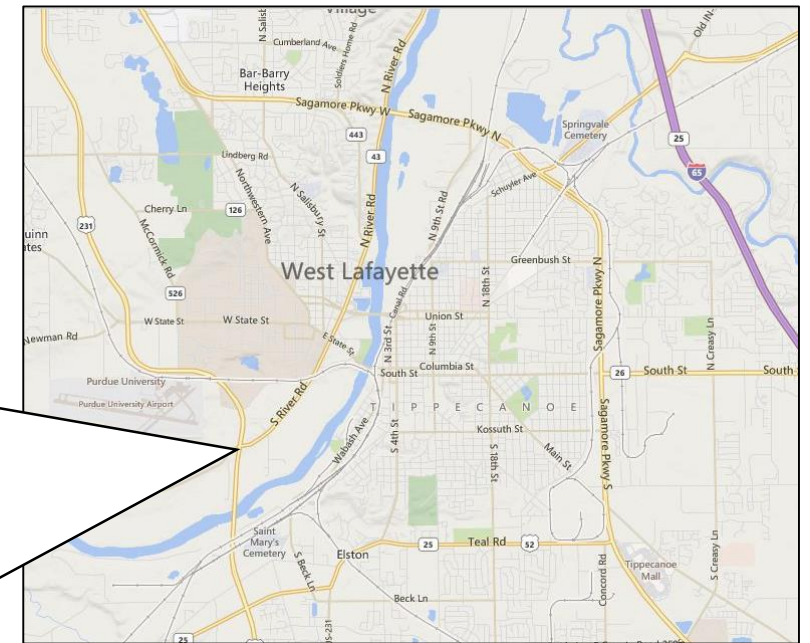
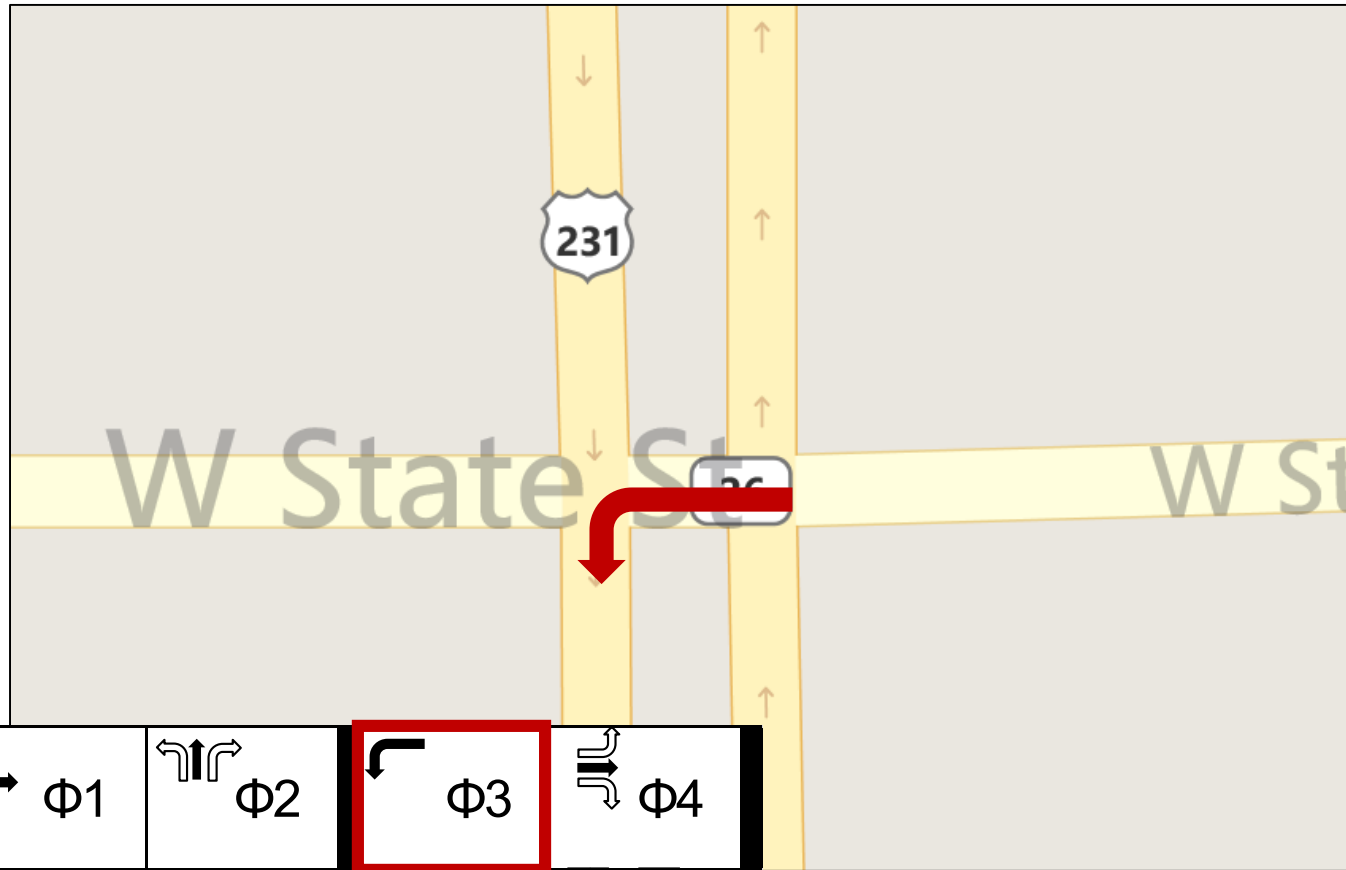

Conceptual Ranking

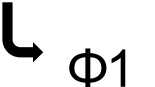
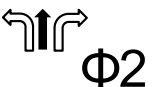

Left Turn Split Extension: US231 & River Rd

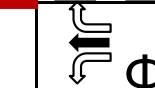

 $\Phi 1$	 $\Phi 2$	 $\Phi 3$	 $\Phi 4$
 $\Phi 5$	 $\Phi 6$	 $\Phi 7$	 $\Phi 8$

EB Left: 1500-1900 Split Increase

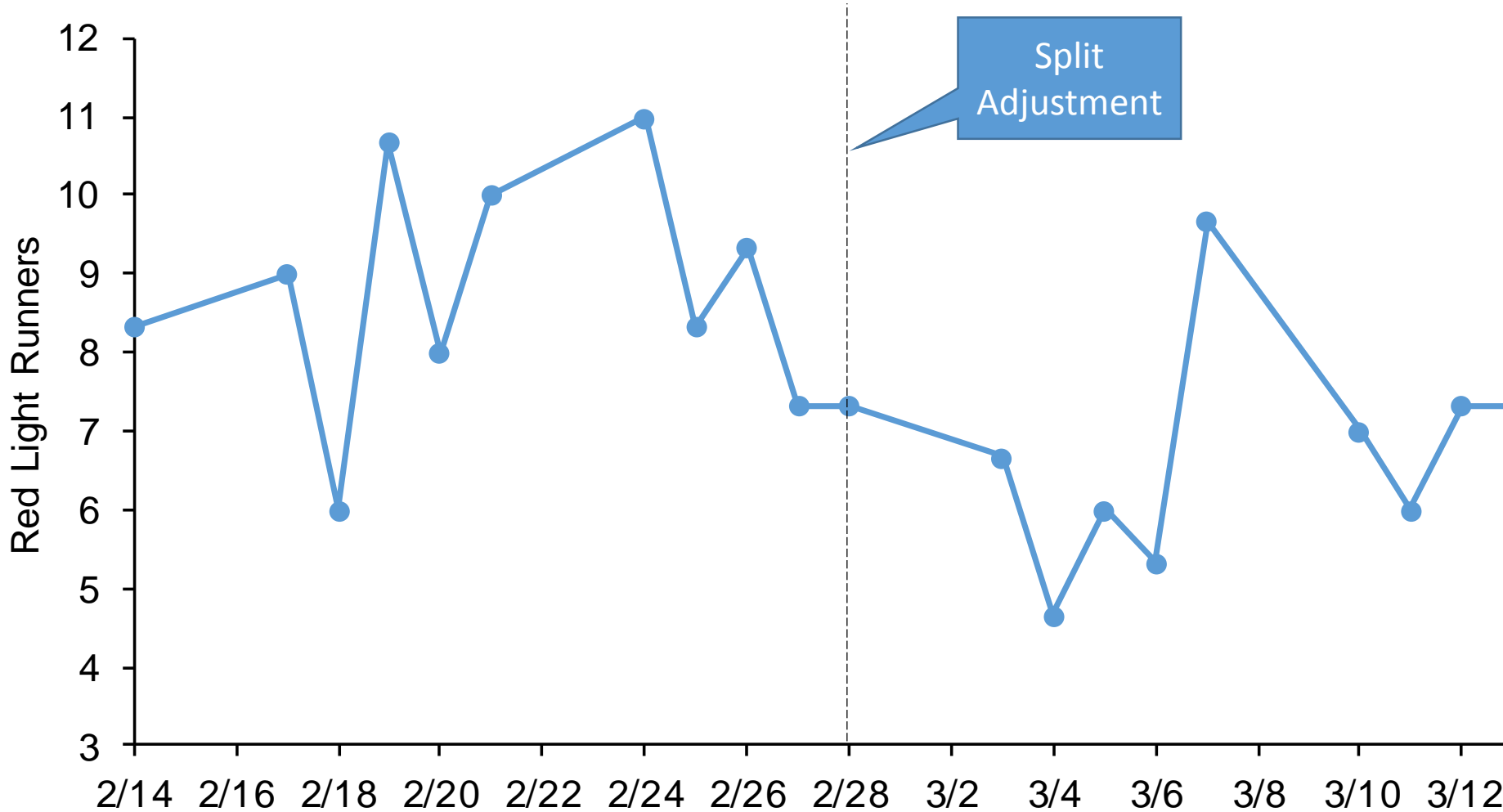
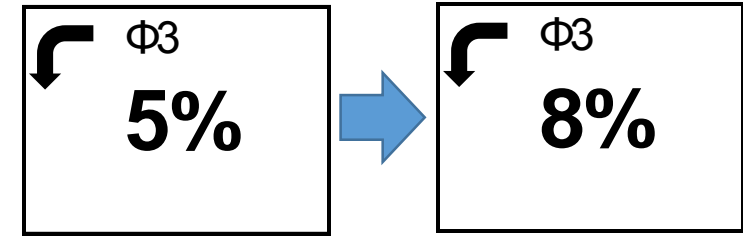

	<i>Before</i>	<i>After</i>
Mean	4.4	3.2
Variance	0.7	0.4
Observations	11	9
Pooled Variance	0.6	
Hypothesized Diff.	0	
Degrees Freedom	18	
t Statistic	3.39	
P(T<=t) one-tail	0.002	
t Critical one-tail	1.73	

Going from Actuated-Coordinated to Fully Actuated Operation: US231 & River Rd

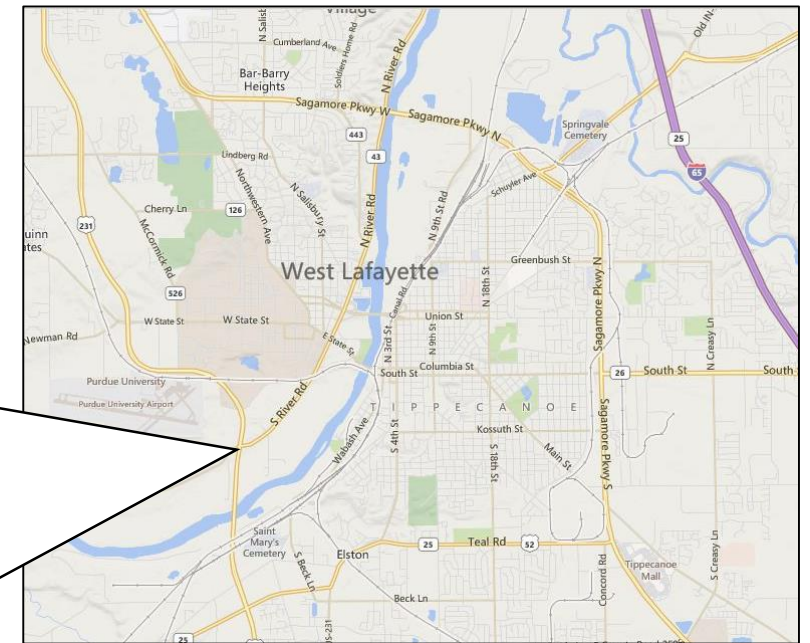
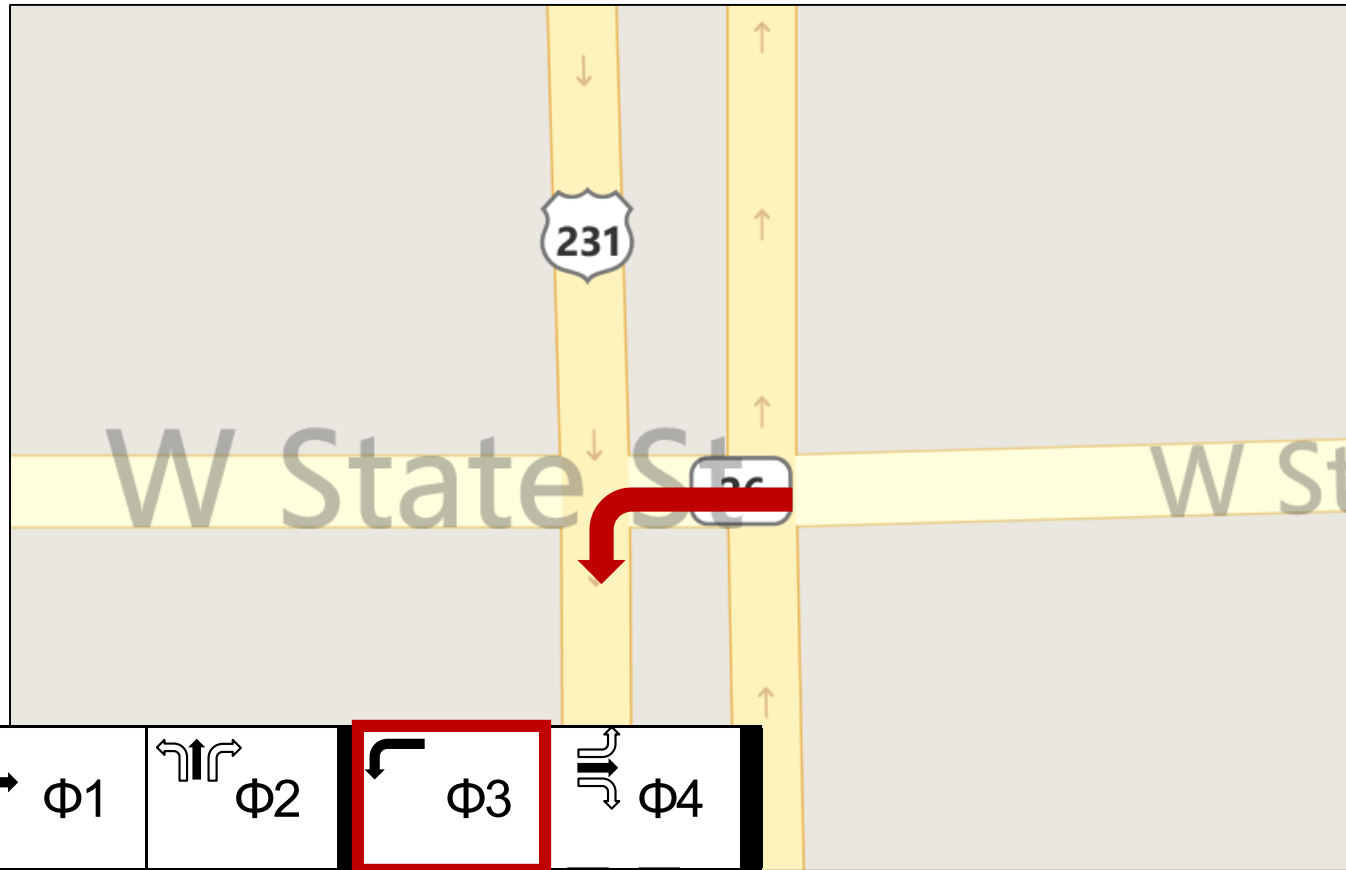

 $\Phi 1$	 $\Phi 2$	 $\Phi 3$	 $\Phi 4$
 $\Phi 5$	 $\Phi 6$	 $\Phi 7$	 $\Phi 8$

EB Left: Coordinated \rightarrow Free

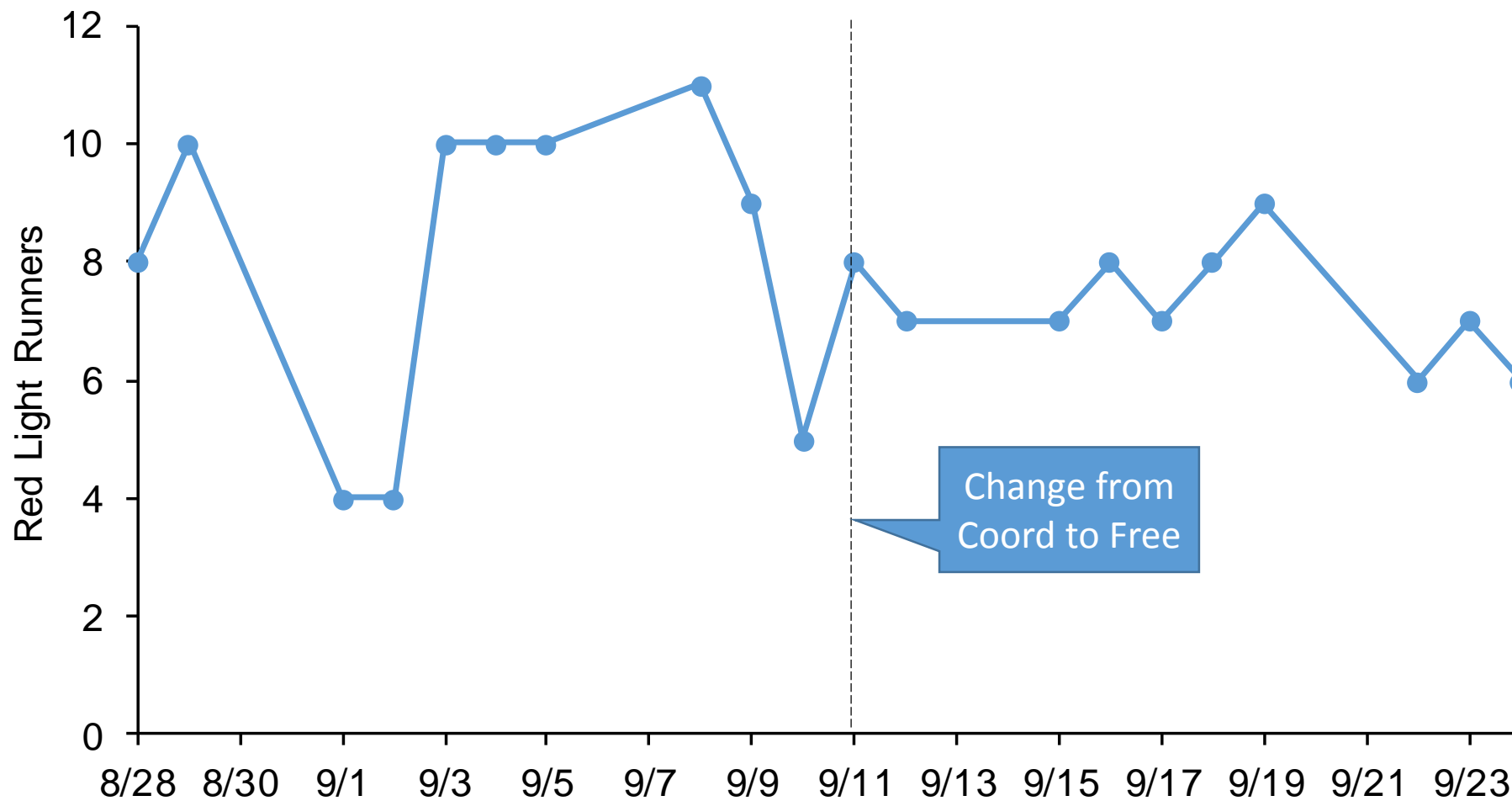
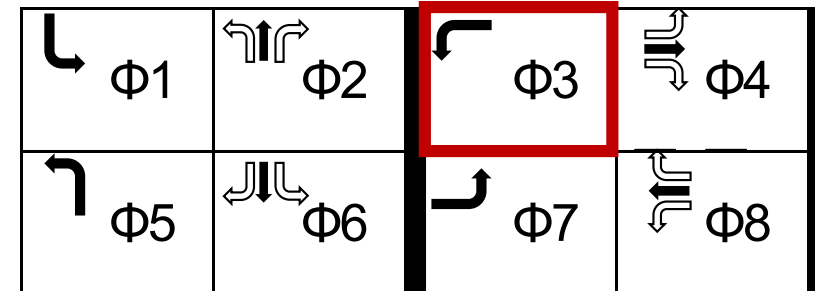

	<i>Before</i>	<i>After</i>
Mean	8.1	7.2
Variance	6.7	0.9
Observations	11	9
Pooled Variance	4.1	
Hypothesized Diff.	0	
Degrees Freedom	18	
t Statistic	0.95	
P(T<=t) one-tail	0.177	
t Critical one-tail	1.73	

Conclusions

- Intersection safety measures using in-place signal infrastructure
- Proper signal database maintenance is crucial
 - Proper phasing, clearance intervals
 - Identification of detector channels, lane movements, etc.
- Evaluation of Countermeasures
- Targeted Law Enforcement Opportunities