

Purdue University Purdue e-Pubs

International Refrigeration and Air Conditioning
Conference

School of Mechanical Engineering

2014

A Discussion about the Methodology to Validate the Correlations of Heat Transfer Coefficients and Pressure Drop during the Condensation in a Finned-Tube Heat Exchanger

Alessandro Pisano

Institute for Energy Engineering, Universitat Politècnica de València, Spain, apisano@iie.upv.es

Santiago Martinez-Ballester

Institute for Energy Engineering, Universitat Politècnica de València, Spain, sanmarba@iie.upv.es

José M. Corberán

Institute for Energy Engineering, Universitat Politècnica de València, Spain, corberan@ter.upv.es

Fernando Hidalgo Monpeán

Thermal and Fluid Engineering Department, Technical University of Cartagena, Spain, fernando.hidalgo@upct.es

Ferdando Illán Gómez

Thermal and Fluid Engineering Department, Technical University of Cartagena, Spain, fernando.illan@upct.es

See next page for additional authors

Follow this and additional works at: <http://docs.lib.purdue.edu/iracc>

Pisano, Alessandro; Martinez-Ballester, Santiago; Corberán, José M.; Hidalgo Monpeán, Fernando; Illán Gómez, Ferdando; and García Cascales, J-Ramón, "A Discussion about the Methodology to Validate the Correlations of Heat Transfer Coefficients and Pressure Drop during the Condensation in a Finned-Tube Heat Exchanger" (2014). *International Refrigeration and Air Conditioning Conference*. Paper 1405.
<http://docs.lib.purdue.edu/iracc/1405>

This document has been made available through Purdue e-Pubs, a service of the Purdue University Libraries. Please contact epubs@purdue.edu for additional information.

Complete proceedings may be acquired in print and on CD-ROM directly from the Ray W. Herrick Laboratories at <https://engineering.purdue.edu/Herrick/Events/orderlit.html>

Authors

Alessandro Pisano, Santiago Martinez-Ballester, José M. Corberán, Fernando Hidalgo Monpeán, Ferdando Illán Gómez, and J-Ramón García Cascales

A Discussion about the Methodology to Validate the Correlations of Heat Transfer Coefficients and Pressure Drop during the Condensation in a Finned-tube Heat Exchanger

Alessandro PISANO ^{1*}, Santiago MARTÍNEZ BALLESTER¹, José Miguel CORBERÁN¹,
Fernando HIDALGO MONPEÁN², Ferdando ILLÁN GÓMEZ², J-Ramón GARCÍA CASCALES²

¹Universitat Politècnica de València, Institute for Energy Engineering,
Camino de Vera, s/n, Valencia, 46022, Spain

²Technical University of Cartagena, Thermal and Fluid Engineering Department,
C/Dr. Fleming, s/n, Cartagena, 30202, Murcia, Spain

* Corresponding author. Tel.: +34 963879120, Fax: +34 96389126, E-mail address: apisano@iie.upv.es
(A. Pisano).

ABSTRACT

The purpose of this work is discuss about the best way for validating a model able to predict the performance of a finned-tube condenser. A simulation tool has been used in order to analyze the effects on the model prediction of some correlations intended to the evaluation of the heat transfer coefficients (HTC) and pressure drop (PD) of both refrigerant and air side. The discussion is supported by an experimental set of data obtained by testing a traditional air-to-water heat pump equipped with a finned round tube condenser. The test campaign has been designed in order to cover a wide range of operating points including different air velocities (from 1.5 m/s to 4 m/s), refrigerant mass flow rate (50.4-82.2 kg/h), air inlet temperatures (20-46°C) and subcooling (0-5-10 K). Once defined the classic boundary conditions for validating a model, such as the condenser inlet conditions (temperature and pressure) and the mass flow rate, the predicted capacity is compared against the experimental one. In the paper an alternative set of boundary conditions is proposed and the results have been compared with experimental ones in terms of condenser temperature and capacity. The analysis of statistical parameters such as Mean Error (ME), Standard Deviation (SD) and Mean Square Error (MSE) allows demonstrating how a good combination of inlet parameters and correlations makes possible a very good agreement between the model and the experimental data without using any enhancement factors.

1. INTRODUCTION

In numerous technological applications and sectors, such as refrigeration, the air conditioning, the automotive sector or the power engineering, the need to exchange heat between different fluids at different temperatures plays a fundamental role. This task is performed by the heat exchangers and, when one of the work fluids is air, by the round-tube and plate-fin heat exchangers (RTPFs) or by the microchannel heat exchangers (MCHXs).

Often, the design or the optimization of a RTPFs heat exchanger are carried out experimentally, methodology characterized by high costs and time consuming, or taking advantage of the application of advanced simulation tools based on suitable analytical models.

As already demonstrated by others authors (Cavallini and Zecchin, 1974, Briggs and Rose, 1994), the phenomenon occurring in a tube during the condensation can be well predicted by a semi-empirical model provided that it is accompanied by the application of the suitable correlations for calculating heat transfer coefficients (HTC) and pressure drop (PD) in both the refrigerant and air.

Some authors, among which Cavallini and Zecchin (1974), Cavallini *et al.* (2001), Cavallini *et al.* (2002), Dobson and Chato (1998), Shah (1976), Thome *et al.* (2003), Tandon (1995), Akers *et al.* (1959), and Haraguchi *et al.* (1994) suggested models and correlations distinguishing the two-phase flow patterns in two macro-categories: stratified (or

wavy) and annular flow. In addition to these ones, others sources (VDI Heat Atlas, 2010; Granryd *et al.*, 2003; Hewitt, 1998; Thome, 2004; ASHRAE, 2013; Boissieux *et al.*, 1999; Dalkilic *et al.*, 2009; Vera-Garcia *et al.*, 2007; Wei *et al.*, 2012) have been reviewed and, according to the complexity of the correlation and suitability to the tested conditions, the correlations proposed by Cavallini *et al.* (2001), Cavallini *et al.* (2002), Dobson and Chato (1998), Shah (1976) and Thome *et al.* (2003) have been considered as the most interesting to be compared and discussed in the present paper.

Regarding the two-phase flow pressure drop evaluation, the correlations of Chisolm (1972) and Friedel (1979) have been used in the model, while, the models proposed by Granryd *et al.* (2003), Wang *et al.* (2000) and its modified version (IMST-Art, 2010) have been considered the most suitable for calculating HTC in the air side.

The discussion is supported by an experimental work including a specific tests campaign designed to cover a wide range of operating points of a RTPFs condenser. Different values of refrigerant mass flow rate, subcooling, air velocity and air inlet temperature have been taken into account.

Two different methodologies of validation have been compared analysing the results by means statistical parameters such as mean error (ME), standard deviation (SD) and mean square error (MSE). The classic boundary conditions for validating a model (Padilla, 2012; Martínez-Ballester *et al.*, 2013, García-Cascales *et al.*, 2010, Vera-Garcia *et al.*, 2007, Shao *et al.* 2009, Jang *et al.*, 2006), such as inlet conditions and mass flow rate of both fluids, have been replaced by subcooling, inlet temperature and massflow rate. Using the traditional methodology, the predicted capacity is compared against the experimental value, while, with the methodology of validation proposed in this paper, the comparison is carried out mainly in terms of both condensation temperature and capacity.

As will be shown below, the best methodology allows getting a high level of agreement between the model results and experimental data without the application of any enhancement factor.

2. EXPERIMENTAL WORK

The tested finned tube condenser is characterized by two asymmetrical circuits (Figure 1), whose main geometric data are described in Table 1.

Table 1: Condenser technical data

General Dimensions	Number of rows	3
	Number of Tube per row	19
	Exchanger Width [m]	0.45
	Long. Spacing [mm]	21.9
	Trans. Spacing [mm]	25.35
	Number of Circuits	2
Tube Data	Tube material	Copper
	Outer Diameter [mm]	9.52
	Thickness [mm]	0.813
	Inner surface	Smooth
Fin Data	Thickness [mm]	0.1
	Fin Pitch [mm]	2.6
	Type	Plain
	Material	Aluminium

The experimental unit is an air-to-water heat pump operating with R134a and equipped with a multi-speed hermetic reciprocating compressor having a displacement of 34.38 cm³, a brazed plate evaporator and an electrostatic valve as expansion device. At the condenser outlet, a liquid receiver imposes the saturated conditions, while a 4-way valve is able to invert the cycle modifying the heat exchanger operation mode (Figure 2). Tests with a certain subcooling will be performed by-passing the liquid receiver and adjusting suitably the refrigerant charge.

The temperature is measured at the condenser inlet and outlet in both refrigerant and air side. A differential transducer allows evaluating the pressure drop in the heat exchanger, while the refrigerant mass flow rate is evaluated by means of a Coriolis.

The experimental campaign has been planned in order to cover several condenser operating conditions. The variable parameters has been classified in two categories: external and internal variables. The first group is composed by the air inlet temperature [20-46 °C] and air velocity [1.5-4 m/s], while the second includes the refrigerant mass flow rate [50.4-82.2 m³/h] and the condenser subcooling [0-5-10°C].

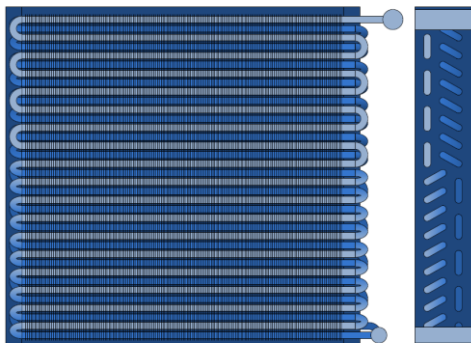

Figure 1: Condenser geometry and circuits.

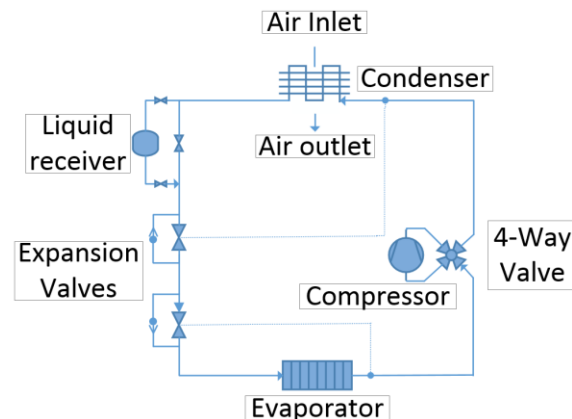

Figure 2: Experimental facilities diagram

3. METHODOLOGIES OF VALIDATION

The commercial software IMST-ART (2010) has been used to predict the performance of the tested condenser. The Finite Volume Method (FVM) is applied to discretize the heat exchanger and the SEWTLE methodology (Corberán et al. 2002) solves the analytical problem.

The validation of the model, using different correlations, will be the objective of this work and will be performed using the experimental data previously described.

Table 3: Values of the coefficients held constant

Correlation subject of analysis	HTC _{2-phase flow} [W/m ² K]	HTC _{air side} [W/m ² K]	PD _{2-phase flow} [Pa/m]	PD _{air side} [Pa/m]
HTC _{ref. side} [W/m ² K]	Correl. analyzed	56.62; 77.33 87.21; 110.09	Exp. value	Exp. value
HTC _{air side} [W/m ² K]	Eq. (1)	Correl. analyzed	Exp. value	Exp. value
PD _{2-phase flow} [Pa/m]	Eq. (1)	56.62; 77.33 87.21; 110.09	Correl. analyzed	Exp. value

In order to isolate the effects of each correlation, when a certain correlation is studied, the rest of the heat transfer coefficients and the pressure drop are kept constant. For instance, if the two phase-flow heat transfer coefficient is studied, the air side heat transfer coefficient and the pressure drop in both refrigerant and air remain constants. The only exception is represented by the one-phase flow coefficient (either vapour or liquid) which are calculated with the correlations of Gnielinski (1976) and Churchill (1977). This decision was taken because it was assumed that they are accurate enough for internal one-phase convection.

All the constant coefficients are resumed in Table 3. They are the result of an initial pre-adjusting of the model, in which, applying a standard set of correlations (IMST-ART, 2010), the best agreement with the experimental data was got through the application of suitable enhancement factors. The constant two-phase heat transfer coefficient was obtained using the follow equation:

$$HTC_{Two-phase} = \left(HTC_{Average} - \frac{A_{One-phase}}{A_{TOT}} \cdot HTC_{One-phase} \right) / \left(\frac{A_{Two-phase}}{A_{TOT}} \right) \quad (1)$$

Where the $HTC_{average}$ and heat exchange areas are provided by the model adjusted. In the same way, also the air-side heat transfer coefficients were determined for each air velocity (1.5, 2.5, 3.2, 4 m/s).

3.1 Correlations for refrigerant heat transfer coefficient

By applying the traditional boundary conditions (condenser inlet condition and mass flow rate), the condenser capacity is commonly used as the comparison parameter in the model validation. Figure 3 and Figure 4 show the validation performed for different condensing correlations. If the condenser capacity is overestimated because of a correlation that overestimates the HTC, also the condenser subcooling is being overestimated getting a maximum error of 7.8°C with Thome *et al.*'s (2003) correlation (Figure 3). Differently, when the heat capacity is underestimated due to a correlation that underestimates the HTC, the condensation process is not completed and the saturated liquid conditions may not be achieved. These effects represent a major drawback to the validation of a condensing correlation since in this way any correlation will be compared in the same conditions. For instance, if a correlation is underestimating the HTC in the high vapour qualities range, may compensate this deviation in the low range of qualities underestimating the same coefficient. The traditional methodology does not allow visualizing this compensation in the results. On the other hand, a correlation that underpredicts the HTC in the high range of vapour quality may be even worse in the low range. Also this behaviour would be hidden, influencing negatively the evaluation of the global HTC as well as the refrigerant charge prediction.

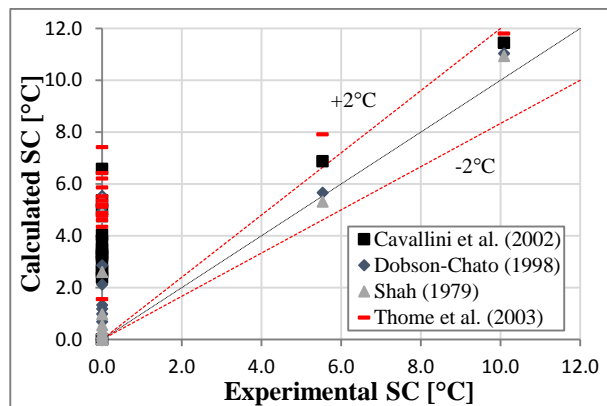

Figure 3: Experimental subcooling against calculated subcooling

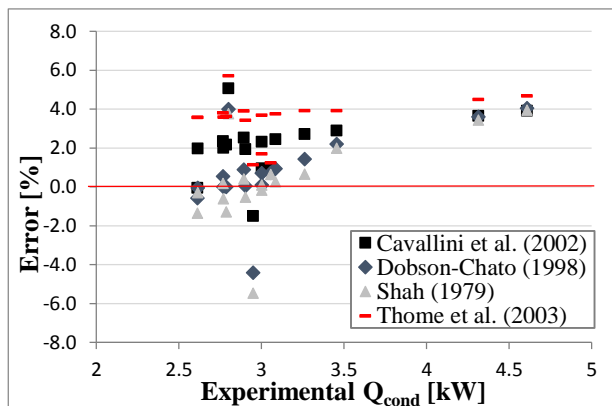

Figure 4: Error committed on heat transfer evaluation

Actually, the objective of a condensing correlation for simulating heat exchangers is predict correctly their global performance rather than predicting accurately the local values of the HTC. Therefore, since in the practical applications there is not any condenser working with two-phase conditions at the outlet, the authors propose to use another set of boundary condition that includes the condenser inlet temperature, the refrigerant mass flow rate and the subcooling. In this way every correlation is tested in whole and same range of vapour quality regardless its accuracy in the condensation path. The results plotted in Figure 5 and Figure 6 show that an over predicting correlation will determine a lower condensing temperature as well as a higher capacity and viceversa.

The different tests of the whole experimental matrix can be sorted in specific groups joint by the variation of the same property such as air temperature, air velocity, subcooling, compressor speed and evaporation temperature. In this way the weight of each parameter on the global prediction can be qualitatively evaluated. These groups are depicted in Figure 5 and Figure 6.

In the same figures can be observed that the air temperature variation at the condenser inlet does not affect negatively the performance of the model, indeed, although it assumes different amplitude, the error is rather constant even with different correlations. Subcooling, compressor speed and evaporation temperature variations affect mainly to the

refrigerant mass flowrate, but it does not affect clearly the magnitude of the error. Differently, the model appears highly sensible to the air velocity variations. This fact points out to an incorrect evaluation of the heat transfer coefficient on the air side. Indeed, in this cases, the global thermal resistance is dominated by the air and the refrigerant has much less effect. Figure 6 shows the same trends as Figure 5 but with opposite sign.

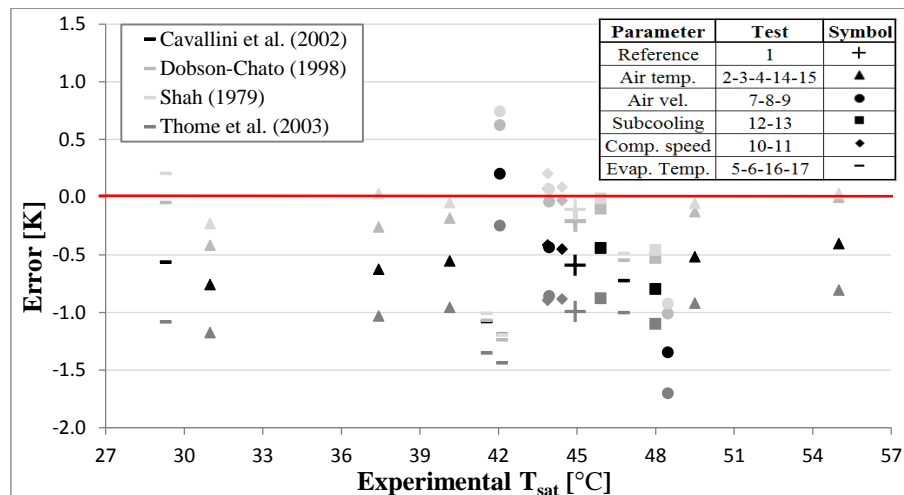

Figure 5: Comparison model plotted versus experimental saturation temperature

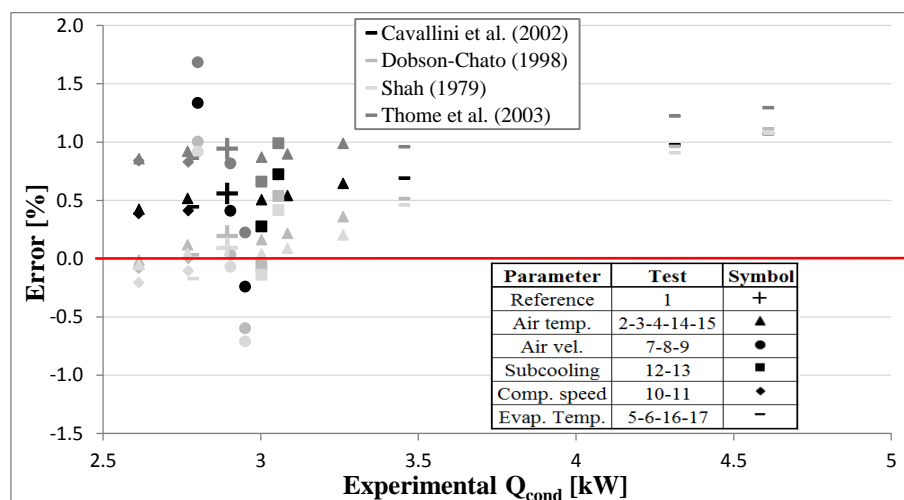

Figure 6: Comparison model versus condenser cooling capacity

In order to quantify the suitability of a correlation or the other, some quality parameters have to be defined. To this end, as shown in Table 4, the analysis of the results has been carried out in terms of mean error (ME), standard deviation (SD) and mean square error (MSE).

Table 4: Analysis of the results: two-phase HTC correlations

	Cavallini et al. (2001)		Dobson-Chato (1998)		Shah (1978)		Thome et al. (2003)	
	T _{cond} [°C]	Q _{cond} [%]	T _{cond} [°C]	Q _{cond} [%]	T _{cond} [°C]	Q _{cond} [%]	T _{cond} [°C]	Q _{cond} [%]
ME	-0.63	0.57	-0.30	0.26	-0.19	0.16	-1.02	0.93
SD	0.354	0.347	0.466	0.445	0.489	0.463	0.308	0.297
MSE	0.51	0.0005	0.29	0.0004	0.26	0.0003	1.13	0.0010

Although the mean error might appear the most important parameter, really, the standard deviation play a fundamental role. Indeed, if the mean error is strongly influenced by the value of the HTC assumed for the air side, the SD provides an important information about the ability of the model to comply with the trend of the experimental data variations.

Therefore, a correlation with high SD means that it is not affected correctly by the varied parameters. Following this reasoning, the correlation of Thome *et al.* (2003) gets the best results.

3.2 Correlations for the air-side heat transfer coefficient

The same analysis of the air side HTC correlations has been carried out taking into account that the refrigerant side HTC, as well as the pressure drop, was maintained constant during the simulations in according to Table 3. The results are shown in Figure 7 and Figure 8 similarly to what was previously done for the refrigerant side HTC.

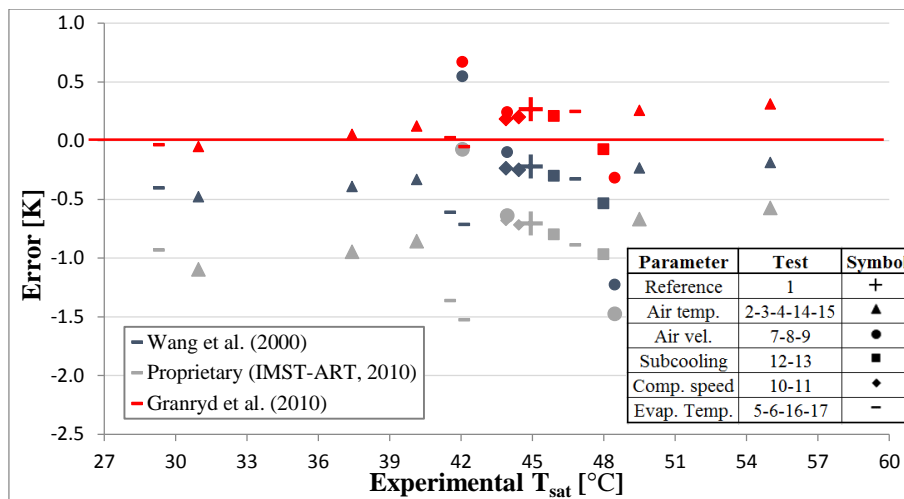

Figure 7: Comparison model plotted versus experimental saturation temperature

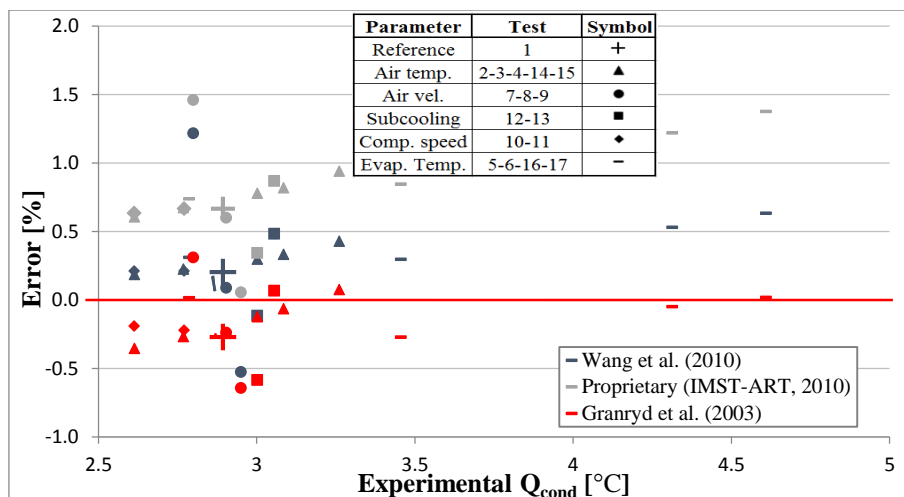

Figure 8: Comparison model versus condenser cooling capacity

Also in this case, the model appears to be quite sensible to the air velocity, while changing the others parameters the trend of the error is quite constant.

As shown in Table 5, the model proposed by Granryd *et al.* (2003) allows getting the best agreement with the experimental set of data. Indeed, in comparison with the others models, mean error, standard deviation and mean square error are characterized by the minimum value.

Table 5: Analysis of the results: air-side HTC correlations

	Wang et al. (2000)		Proprietary (IMST-ART, 2010)		Granryd et al. (2003)	
	T_{cond} [°C]	Q_{cond} [%]	T_{cond} [°C]	Q_{cond} [%]	T_{cond} [°C]	Q_{cond} [%]
ME	-0.351	0.295	-0.875	0.783	0.135	-0.163
SD	0.351	0.354	0.355	0.344	0.217	0.239
MSE	0.239	0.0002	0.885	0.001	0.062	0.0001

3.3 Global Validation

The last step of the validation involves the repetition of the simulations applying the Granryd *et al.*'s model (2003) for evaluating the air side HTC and the Thome *et al.*'s correlation (2003) for the refrigerant side HTC. Once applied these correlations, in order to demonstrate the best agreement with the experimental data, in the following figures the results are compared with those obtained by means of the others correlations analyzed. The comparison is carried out distinguishing the effects on the performance of air temperature (Figure 9, 10), subcooling (Figure 11, 12), compressor speed (Figure 13, 14) and air velocity (Figure 15, 16).

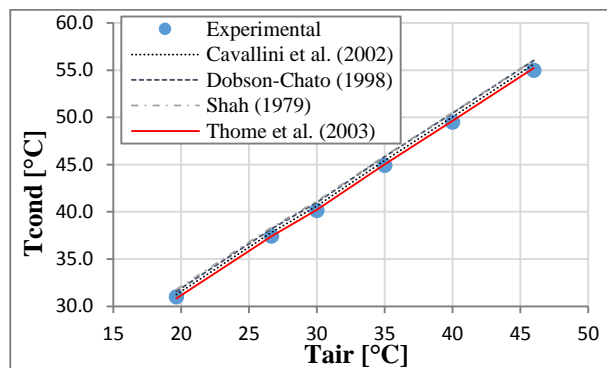

Figure 9: Cond. temperature versus Inlet air temperature

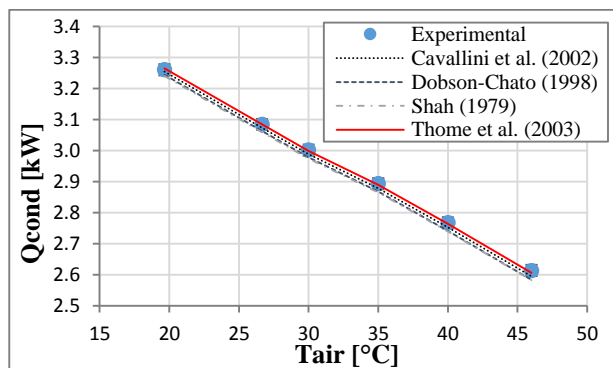

Figure 10: Capacity versus Inlet air temperature

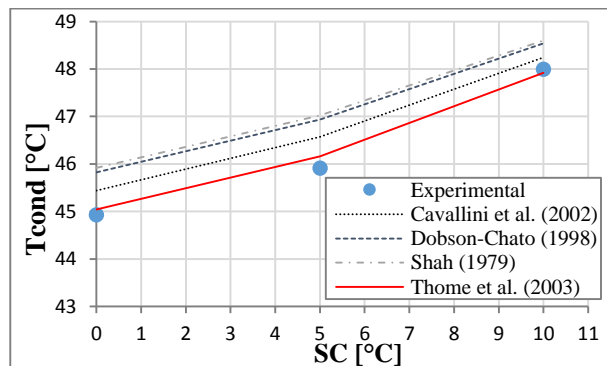

Figure 11: Cond. temperature versus subcooling

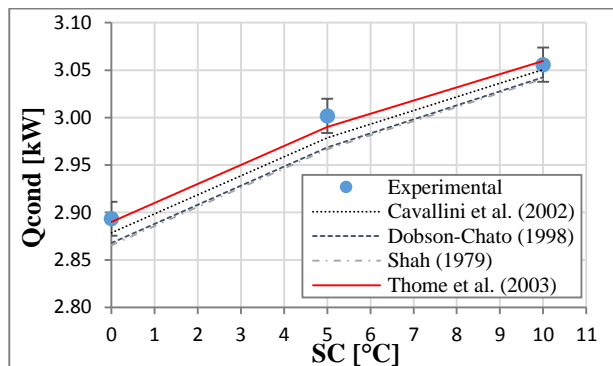

Figure 12: Capacity versus subcooling

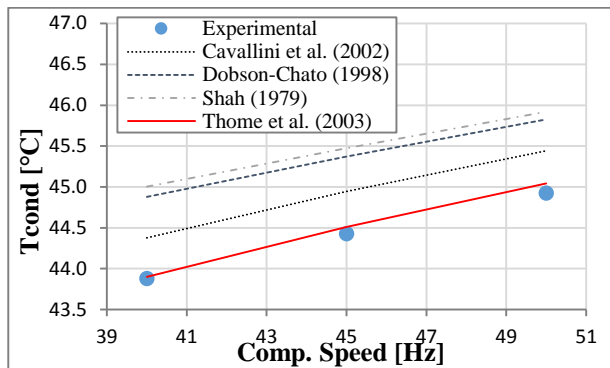

Figure 13: Cond. temperature versus comp. speed

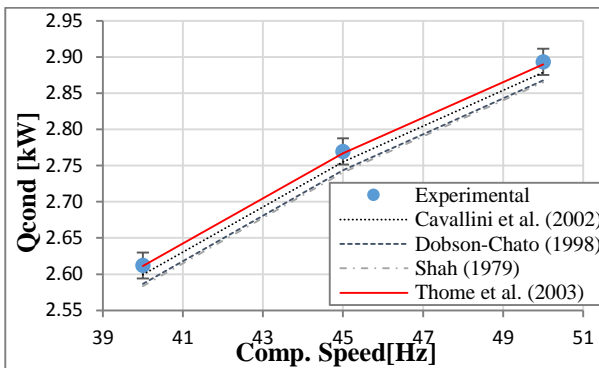

Figure 14: Capacity versus comp. speed

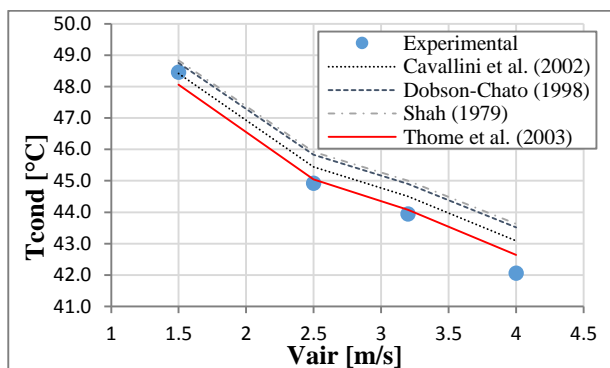

Figure 15: Cond. temperature versus air velocity

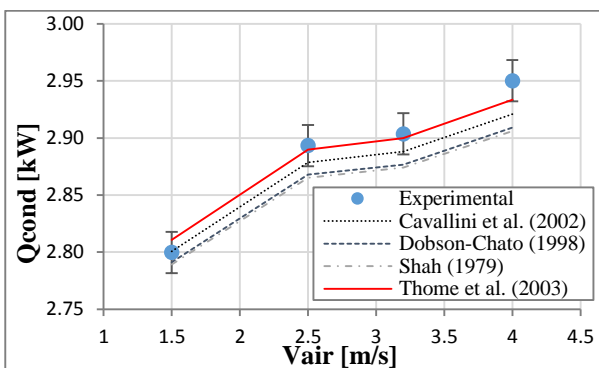

Figure 16: Capacity versus air velocity

The ME and the SD assume the values of 0.8 and $\pm 0.221^{\circ}\text{C}$ in terms of condensation temperature, while they get respectively 0.11 and $\pm 0.245\%$ in terms of capacity. These results show that, in all the different operating conditions, the model is able to fit with high accuracy to the experimental set of data. In conclusion, the methodology proposed, as well as guarantee a deep study of the correlations mentioned, allows adjusting the global model without using any enhancement factor but only combining appropriately the HTC models.

3.2 Refrigerant-side pressure drop

In any finned tube heat exchanger the total pressure drop is strongly affected by its geometry and characteristics, therefore, its evaluation turns out to be fairly hard by means a simple model.

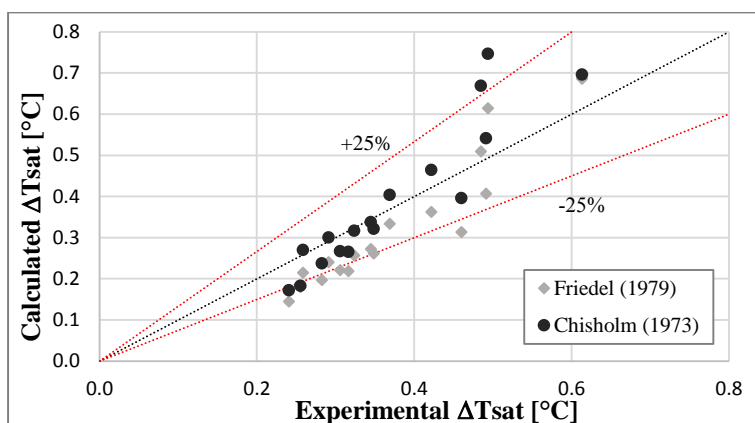

Figure 17: Experimental pressure drop versus Calculated pressure drop

The correlations proposed by Chisholm (1973) and Friedel (1979) are aimed to evaluate the frictional pressure drop during the two-phase flow. In both condenser and evaporator, representing the most significant contribute, the evaluation of this addend takes on high importance in order to estimate correctly the total pressure drop. Including the pressure drop due to the returns bends, the comparison against the overall set of experimental data is depicted in Figure 17.

As previously, also in this case the results have been analysed in term of statistic parameters. The Friedel's correlation underpredicts the pressure drop (ME and SD equal to -17.9% and $\pm 16.9\%$), while the Chisholm's correlation, even though the mean error assumes 0.8%, presents a higher dispersion of the results (SD equal to $\pm 21\%$).

4. CONCLUSIONS

In this paper a discussion about the validation of the model for calculating heat transfer coefficients and pressure drop in a finned tube heat exchanger has been carried out. The limits of a traditional methodology have been highlighted and a different methodology has been proposed choosing a different set of boundary conditions. Inlet temperature, subcooling and mass flow rate have been assigned, while the influence of each correlation on the results has been evaluate in terms of condensation temperature and capacity. An experimental campaign has allowed determining the operating factors which influence negatively the models prediction. The model turns out to be highly sensible to the air velocity more than air temperature, subcooling and compressor speed. Furthermore, the results has been discussed in term of statistic index such as Mean Error, Mean Square Error and Standard Deviation. The analysis has lead the following results:

- The most important statistic parameter is the standard deviation instead of the mean deviation.
- The lowest Stander deviation in obtained by the models proposed by Thome *et al.*'s (2003) for evaluating the heat transfer coefficient in the refrigerant side and Granryd *et al.*'s (2003) correlation for evaluating the same coefficient in air side.
- The application of both this models allows getting a very good agreement with the experimental data without applying any enhancement factor.
- The error committed by the model are inside an error band of $\pm 0.2^\circ\text{C}$ for the condensation temperature and in a band of $\pm 0.25\%$ in terms of capacity.

In IMST-ART the total pressure drop includes both the frictional pressure drop and returns bends pressure drop. The model prediction has been compared with the experimental data providing these results:

- The Fridel's correlation (1979) underpredics the total pressure drop (ME equal to -17.9%) with a SD equal to $\pm 16.9\%$.
- The Chisholm's correlation (1973) allows getting more accurate results in terms of mean error (0.8%) but it is affected by a higher standard deviation ($\pm 21\%$).

REFERENCES

- Akers, W.W., Deans, H.A. Crosser, O.K., 1959, Condensation Heat transfer within horizontal tubes, *Chem. Eng. Prog. Symp. Ser.*, Vol. 55, p. 171-176.
- ASHRAE Handbook, 2013, Fundamentals, ASHRAE, Atlanta.
- Boissieux, X., Heikal, M.R., Johns, R.A., 1999, Two-Phase heat transfer coefficients of three HFC refrigerants inside a horizontal smooth tube, part II: condensation, *International Journal of Refrigeration*, Vol. 23, p. 345-352.
- Briggs, A., Rose, J.W., 1994, Effect of fin efficiency on a model for condensation heat transfer on a horizontal, integral-fine tube, *Int. J. of Heat and Mass Transfer*, Vol. 37, p. 457-463.
- Cavallini, A., Zecchin, R., 1974, A dimensionless correlation for heat transfer in forced convention condensation, *Proceedings sixth International Heat Transfer Conference*, Vol. 3, p. 309-313.
- Cavallini, A., Censi, G., Del Col, D., Doretti, L., Longo, G.A., Rossetto, L., 2001. Experimental investigation on condensation heat transfer and pressure drop of new HFC refrigerants in a horizontal tube, *International Journal of Refrigeration*, Vol. 24, p. 73-87.
- Cavallini, A., Censi, G., Del Col, D., Doretti, L., Longo, G.A., Rossetto L., 2002, In-tube condensation of halogenated refrigerants, *ASHRAE Trans.*, 108 (1), pp. 146-161.

- Chisholm, D., 1973, Pressure gradients due to friction during the flow of evaporating two-phase mixtures in smooth tubes and channels, *Int. J. Heat Mass Transfer*, Vol. 16, p. 347.
- Churchill, S. W., 1977, Friction-Factor Equation Spans All Fluid-Flow Regimes, *Chemical Engineering*, pp. 91-92.
- Corberán, J.M., De Cordoba, P.F., Gonzalez, J., Alias, F., 2001. Semiexplicit Method for Wall Temperature Linked Equations (SEWTLE): A General Finite-Volume Technique for the Calculation of Complex Heat Exchangers. *Numer. Heat Transfer, Part B* 40, 37-59.
- Dalkilic, A.S., Wongwises, S., 2009, Intensive literature review of condensation inside smooth and enhanced tubes, *International Journal of Refrigeration*, Vol. 52, p. 3409-3426.
- Dobson, M.K., Chato J.C., 1998, Condensation in smooth horizontal tubes, *J. Heat transfer*, 120, p. 193-213.
- Friedel, L., 1979, New friction pressure drop correlations for upward, horizontal and downward two-phase pipe flow, HTFS Symposium, Oxford, (Hoechst AG Reference 372217/24 698).
- García-Cascales, J.R., Vera-García, F., González-Maciá, J., Corberán-Salvador, J.M., Johnson, M.W., Kohler, G.T., 2010, Compact Heat Exchangers Modeling: Condensation. *Int. J. Refrigeration*, Vol. 33, 135-147.
- Gnielinski, V., 1976, New equations for heat and mass transfer in turbulent pipe and channel flow, *Int. Chem. Eng.*, Vol. 16, p. 359-368.
- Granryd, E., Ekroth, I., Lundqvist, P., Ake, M., Palm, B., Rohlin, P., 2003, *Refrigerating Engineering*, Department of Energy Technology, Royal Institute of technology, KTH, Stockholm.
- Haraguchi, H., Koyama S., Fujii T., 1994, Condensation of refrigerants HCFC22, HFC134a and HCFC123 in a horizontal smooth tube (2nd report, proposal of empirical expressions for local heat transfer coefficient), *Trans. JSME* 60 (574), 245-252.
- Hewitt, G.F., 1998, *Heat Exchanger Design Handbook, part II*, Begel House, INC, New York.
- IMST-ART, 2010, Simulation tool to assist the selection, design and optimization of refrigerator, <http://www.imst-art.com>.
- Jiang, H., Aute, V., Radermacher, R., 2006, CoilDesigner: a general-purpose simulation and design tool for air-to-refrigerant heat exchangers, *Int. Journal of refrigeration*, Vol. 29, p 601-610.
- Martínez-Ballester, S., Corberán, José-M., González-Maciá, J., 2013. Numerical Model for Microchannel Condensers and Gas Coolers: Part I – Model Description and Validation. *International Journal of Refrigeration*, 36 (1), pp. 173-190.
- Padilla, y., 2012. Experimentally validated models of refrigerant distribution in microchannel heat exchangers used to evaluate charge reduction of various working fluids, Master thesis, University of Illinois, Urbana-Champaign.
- Shao L-L, Yang, L., Zhang, C-L, Gu, B., 2009, Numerical modelling of serpentine microchannels condensers, *International Journal of Refrigeration*, Vol. 32, p. 1162-1172.
- Shah, M.M., 1979, A general correlation for heat transfer during film condensation inside pipes, *Int. J. Heat and Mass Transfer*, Vol. 22, p. 547-556.
- Tandon, T.N., Varma, H.K., Gupta, C.P., 1995, Heat transfer during forced convection inside horizontal tube, *Int. J. Refrig.*, Vol. 18, p. 210-214.
- Thome, J.R., El Hajal, J., Cavallini A., 2003, Condensation in horizontal tubes, part 2: new heat transfer model based on flow regimes, *Int. J. Heat and Mass Transfer*, Vol. 46, p. 3365-3387.
- Thome, J.R., 2004, *Wolverine Engineering Data Book III*, Wolverine tube, INC.
- Verein Deutscher Ingenieure VDI-Gesellschaft Verfahrenstechnik und Chemieingenieurwesen (GVC), 2010, *VDI Heat Atlas*, Second Edition, Springer.
- Vera-García, F., Garcia-Cascales, J.R., Corberán-Salvador, J.M., Gonzalves-Macia, J., Fuentes-Díaz, D. 2007, Assessment of condensation heat transfer correlations in the modelling of fin and tube heat exchangers, *International Journal of Refrigeration.*, Vol. 30, p. 1018-1028.
- Wang, Chi-Chuan, Chi, Kuan-Yu, Chang, Chun-Jung, 2000, Heat transfer and friction characteristics of plain fin-and-tube heat exchangers, part I-II, *International Journal of Heat and Mass Transfer*, Vol 43, pp. 2681-2691/2693-2700.
- Wei, X., Fang, X., Shi, R. 2012, A comparative study of heat transfer coefficients for film condensation, *Energy Science and Technology*, Vol. 3, p. 1-9.

ACKNOWLEDGEMENT

The work of Alessandro Pisano on this project was partially supported by the Ministry for Economy and Finance of Spain, under the Training of Researcher program (FPI). Financial support from the Ministry for Economy and Finance of Spain, project numbers: DPI2011-26771-C02-01 is also gratefully acknowledged.