

Purdue University
Purdue e-Pubs

International Compressor Engineering Conference

School of Mechanical Engineering

2014

Experimental Analysis of Refrigerant Flow in Small Clearances

Ernane Silva

POLO/UFSC, Brazil, ernane@polo.ufsc.br

Marcos Rojas-Cárdenas

POLO/UFSC, Brazil, marcos.rojas@polo.ufsc.br

Cesar J. Deschamps

POLO/UFSC, Brazil, deschamps@polo.ufsc.br

Follow this and additional works at: <https://docs.lib.purdue.edu/icec>

Silva, Ernane; Rojas-Cárdenas, Marcos; and Deschamps, Cesar J., "Experimental Analysis of Refrigerant Flow in Small Clearances" (2014). *International Compressor Engineering Conference*. Paper 2326.
<https://docs.lib.purdue.edu/icec/2326>

This document has been made available through Purdue e-Pubs, a service of the Purdue University Libraries. Please contact epubs@purdue.edu for additional information.

Complete proceedings may be acquired in print and on CD-ROM directly from the Ray W. Herrick Laboratories at <https://engineering.purdue.edu/Herrick/Events/orderlit.html>

Experimental Analysis of Refrigerant Flow in Small Clearances

Ernane SILVA, Marcos ROJAS-CARDENAS, Cesar J. DESCHAMPS*

POLO Research Laboratories for Emerging Technologies in Cooling and Thermophysics
Federal University of Santa Catarina
Florianópolis, SC, Brazil
deschamps@polo.ufsc.br

* Corresponding Author

ABSTRACT

An important source of thermodynamic and volumetric inefficiency in compressors is the leakage of gas through clearances. For instance, in reciprocating compressors this leakage may occur through the piston-cylinder gap or between the valve and its seat. Due to the fact that for some specific situations the characteristic length of these clearances can be of the same order of magnitude as the gas molecular mean free path, gas rarefaction must be taken into account in the modeling of the fluid flow. Under these conditions, the conventional continuum approach is not appropriate in order to predict the flow and alternative formulations on the basis of the kinetic theory of gases must be sought. Typical examples of non-equilibrium phenomena which cannot be predicted by the classical Navier-Stokes equations are slip, thermal transpiration and temperature jump in the proximities of the solid boundaries containing the fluid. In this work we propose an original compact experimental device that allows the characterization of gas flows in micrometric clearances. Through the aid of this device coefficients, such as the viscous slip coefficient to be introduced in the modified boundary conditions of the Navier-Stokes equations for slightly rarefied, will be obtained. These coefficients are necessary in order to model rarefied gas flows, and they can be as important as the coefficient of viscosity and thermal conductivity. Furthermore, the experimental results obtained will help us to validate a numerical model that predicts gas-leakages in compressors that was developed in-situ.

1. INTRODUCTION

Gas leakage is a well-known source of inefficiency of compressors because an amount of the compression work is lost with the gas that leaks. In addition to that, gas leakage also acts to increase the gas suction temperature, causing a reduction of the volumetric efficiency and an increase of the compression work per unit mass. Gas leakage in scroll compressors occurs mainly in the flank and top clearances, while in the reciprocating compressor it takes place in the piston-cylinder gap and in the incomplete sealing of valves. Recently, Silva and Deschamps (2012) conducted a numerical analysis about the leakage in reed valves of reciprocating compressors. The authors found that valve leakage may significantly deteriorate the compressor performance even for very small clearances between the valve and its seat.

For some specific conditions of the compression cycle a rarefied flow regime is established. In this situation non-continuum effects, such as slip, thermal transpiration and temperature jump at the wall, are significant, and they must be taken into account. For this case of configuration the classical Navier-Stokes equations are not appropriate anymore. As a function of the gas rarefaction different flow regimes can be identified (hydrodynamic, slip, transitional, and free molecular flow) and the parameter used in order to characterize these flow regimes is the Knudsen number (Kn) which is defined as the ratio between the gas molecular mean free (λ) and the characteristic length of the system (l). A second parameter of use is the rarefaction parameter (δ) which is inversely proportional to the Knudsen number.

$$\delta = \frac{\sqrt{\pi}}{2} \frac{l}{\lambda} = \frac{\sqrt{\pi}}{2} \frac{1}{Kn} \quad (1)$$

Based on the hard sphere model for molecular interaction (Bird, 1994), the mean free path is defined as

$$\lambda = \frac{\sqrt{\pi}}{2} \frac{\mu}{P} (2\mathfrak{R}T)^{1/2} \quad (2)$$

where μ is the gas viscosity, which depends on the temperature, P is the pressure of the gas, \mathfrak{R} is the specific gas constant, and T is the temperature of the gas.

Different methods have been employed to measure the mass flow rate of gases through small channels. The simpler ones involve the use of flow meters (Jang and Wereley, 2004). However, their use is limited to mass flow rates which are higher than 10^{-8} kg/s. Thus, different techniques have been employed in the literature in order to measure micro-gas flows. The most commons are: the constant-volume (Arkilic *et al.*, 1997; Ewart *et al.*, 2006) and the drop tracking method \mathfrak{s} (Colin *et al.*, 2004; Ewart *et al.*, 2006).

This experimental work aims to measure gas flows through micro-devices by the aid of the constant-volume technique. By employing this methodology we closely reproduce the case of configuration found in compressors, where the gas leaks through micro-metric clearances. Through the aid of this device, coefficients, such as the viscous slip coefficient to be introduced in the modified boundary conditions of the Navier-Stokes equations for slightly rarefied, will be obtained. These coefficients are necessary in order to model rarefied gas flows, and they can be as important as the coefficient of viscosity and thermal conductivity. Furthermore, the experimental results obtained will help us validate a home-made numerical model that predicts gas-leakages in compressors.

2. EXPERIMENTAL APPARATUS AND METHODOLOGY

The constant volume technique consists in the tracking with time of the pressure variation inside two tanks which are positioned at the inlet and outlet of the micro-device studied. The pressure variation with time is then associated to the mass flow rate entering the tank.

Therefore the experimental apparatus consisted in two rigid reservoirs equipped with pressure and temperature sensors. The rigid tanks were connected by a micro-tube (Figure 1). In order to emulate the rarefaction range of the specific case of configuration that we wanted to study, it was necessary to lower the pressure inside the test section to vacuum conditions. This was achieved by means of a turbo molecular vacuum pump. For this case of configuration, INFICON capacitance diaphragm gauges (CDG) with full scale of 1333Pa and 133Pa (accuracy 0.2% of reading) were used to measure pressure in the upstream and downstream reservoirs, respectively, while type T thermocouples were used to measure temperature. The volumes V_{UP} and V_{DOWN} of the reservoirs were accurately measured. The upstream and downstream nominal volumes were 180.94cm^3 and 28.40cm^3 , respectively. Finally, a tank containing nitrogen was connected to the upstream volume.

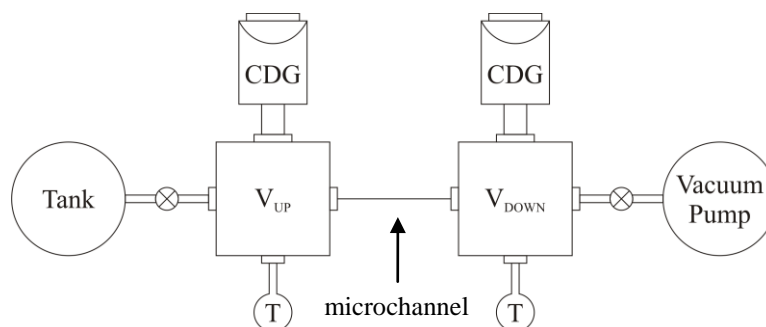

Figure 1: Experimental apparatus

For each test, after that a specific pressure difference between the upstream and downstream reservoirs was adjusted to a desired value, the closed system was let free to relax to its natural thermodynamic equilibrium configuration, that is pressure equality. The mass flow rate through the channel was equal to the absolute mass flow rate leaving or entering the volumes and its value can be deduced by relating the mass variation with time inside the reservoirs to the pressure variation. The pressure evolution with time inside the reservoirs was induced by the initial pressure disequilibrium imposed in the system. Figure 2 presents the pressures variations in the upstream and downstream reservoirs until thermodynamic equilibrium is reached for a single test. The pressure changes are more pronounced in the smaller reservoir, which is the downstream volume.

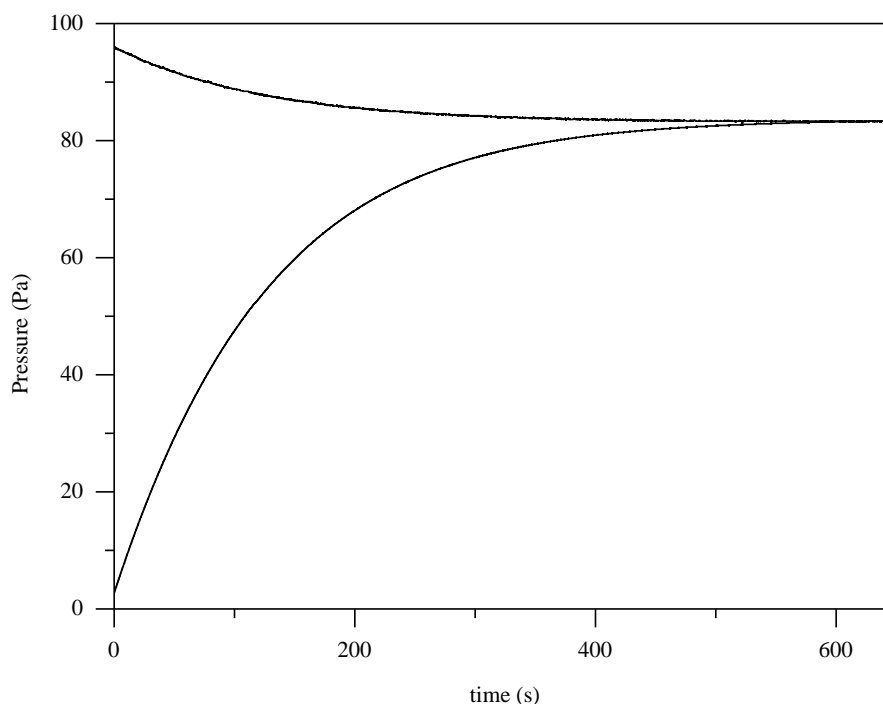

Figure 2: Pressure variation with time

By using the ideal gas equation of state and by keeping both reservoirs rigorously under isothermal conditions, the mass flow rate flowing in the micro-tube, \dot{m} , can be related to the pressure variation with time in the tanks and it can be calculated as

$$\dot{m} = \frac{dm}{dt} = \frac{V}{\mathcal{R}T} \frac{dP}{dt} \quad (3)$$

where V was the volume of the upstream or downstream reservoir. Since a limited number of pressure measurements were recorded during the extent of one single experiment, a curve fitting process was performed to obtain a smooth pressure derivative.

The micro-tube was manufactured in resin and it was positioned inside a stainless steel tube (Figure 3). The micro-tube's nominal diameter is 0.42mm.

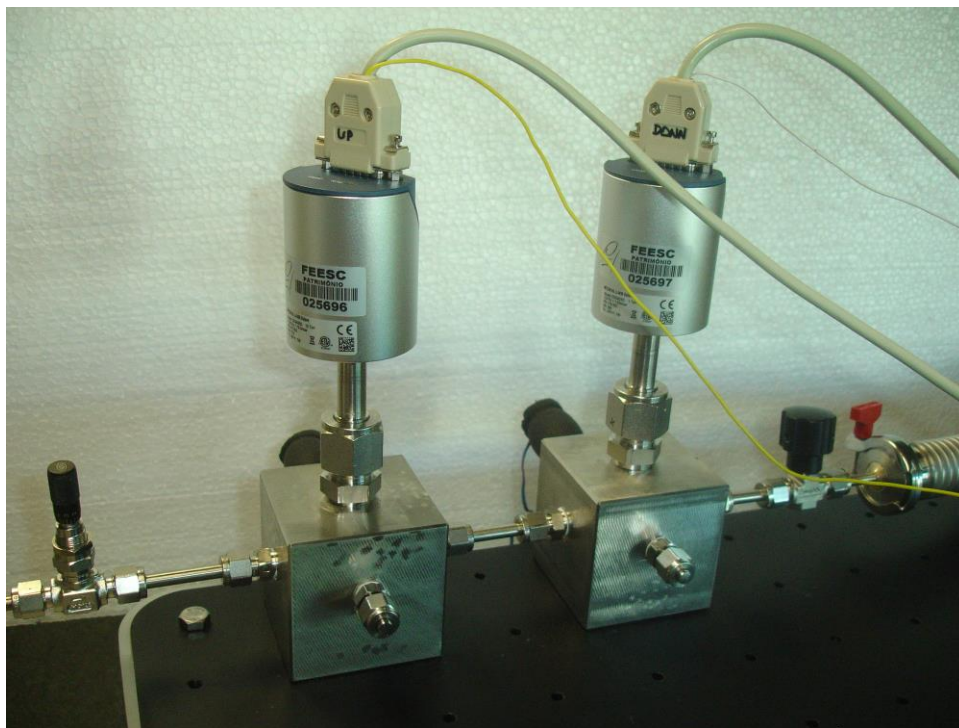

Figure 3: Experimental apparatus

In order to assure that the test-section was leak-free, tests were carried out. As it can be seen from Figure 3, the pressure in the vessels could be maintained constant for long periods of time, meaning that air was not able to leak inside the experimental test-section, which was under high vacuum conditions. The fluctuations that can be observed in the plot relate to fluctuations of temperature inside the reservoir. Nevertheless, these fluctuations were estimated to be negligible in respect to the mass flow rate measurements effectuated since they were lower than $dT/T < 5 \cdot 10^{-4}$ during one single experiment. Thus, the conditions in the tanks were considered as isothermal, too.

The experiments were performed for different nominal pressures in the system in order to consider a large spectrum of gas rarefaction. Furthermore, the mass flow rates were obtained for different pressure differences applied. The gas used was nitrogen. Figures 4 and 5 present the temperature variation with time for a single test and a leak test, respectively.

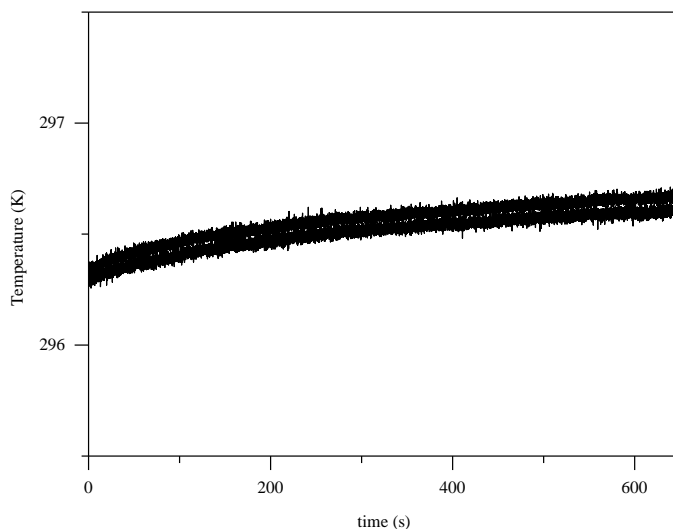

Figure 4: Temperature variation with time

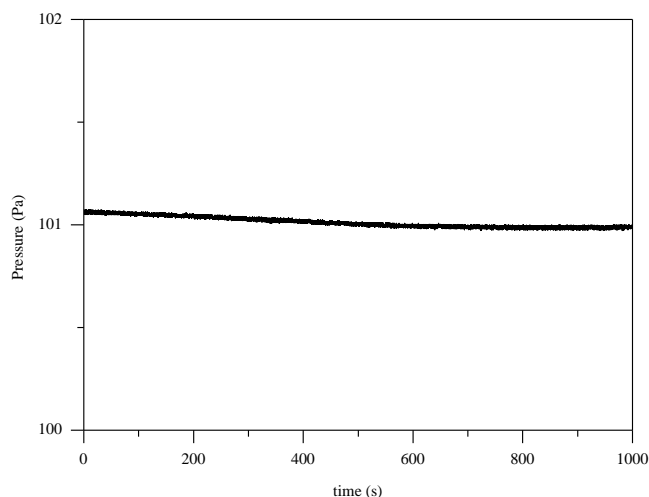

Figure 5: Leak test

3. EXPERIMENTAL RESULTS AND NUMERICAL COMPARISON

As previously described, flows in MEMS, specifically for cases when the molecular mean free path of the gas (λ) is in the same order of dimensions in respect to the characteristic length of the system (l), can be greatly affected by viscous and thermal slip at the walls. These phenomena are negligible in hydrodynamic regime flows. On the one hand, if the flow is highly rarefied ($\lambda \gg l$), that is in free molecular and transition regime, the fluid flow must be solved on the basis of the Boltzmann equation by using tools such as the model kinetic equations (the Bhatnagar-Gross-Krook model, the Shakhov model, the Elliptic model) or the direct simulation Monte Carlo method (DSMC). On the other hand, if the flow is slightly rarefied, that is for slip regime conditions, the fluid flow can be solved by applying modified boundary conditions to the Navier-Stokes equations, that is viscous and thermal slip conditions at the wall. In order to apply these theoretical methodologies, it is necessary to understand the physics of non-equilibrium involved along the Knudsen layer over the device's surface, or in other words, the gas/surface interaction. Often this interaction is represented by means of physically meaningful coefficients, like the tangential momentum accommodation coefficients. This coefficient can vary as a function of the molecular constitution of the gas, the solid surface material and the solid surface roughness, as well as a function of the temperature of the flow. At the present time, sufficient experimental investigation on these coefficients is still lacking.

Independently from the rarefied flow regime, the gas-surface interaction is at the center of the definition of the coefficients. The tangential momentum accommodation coefficient (σ), is a balance between the pre-collision momentum (τ_i) of the molecule and the reflected post-collision momentum (τ_r) in respect to the momentum of the wall (τ_w).

$$\sigma = \frac{\tau_i - \tau_r}{\tau_i - \tau_w} \quad (4)$$

The TMAC varies from 0 to 1, where 0 indicates a specular reflection and 1 refers to a complete diffuse reflection of the molecule at the wall. On the one hand, in a perfectly smooth surface, the tangential momentum coefficient is equal to zero since the molecules do not change tangential momentum after collision with the walls. On the other hand, for rough surfaces the TMAC is equal to one, since the molecules are reflected from the wall with an averaged tangential velocity that is equal to the one of the wall (Karniadakis *et al.*, 2005).

Numerical results obtained by Graur and Sharipov (2009) on the basis of the S-model kinetic equation are used for comparison with our experimental results in Figure 6. The non-dimensional mass flow rate is plotted which was defined as

$$G = -\frac{1}{\pi R^3} \frac{L}{(P_{up} - P_{down})} (2\mathcal{R}T)^{1/2} \dot{m} \quad (5)$$

where R is the radius of the microtube, L is its length, and P_{up} and P_{down} are the pressures in the upstream and downstream reservoirs, respectively.

As can be seen, a good agreement was observed between experimental and theoretical data in the $0.5 \leq \delta \leq 10$ range. However, a constant offset seems to exist in the whole range analyzed. It may be caused by an incomplete accommodation of the molecules at the walls ($\sigma < 1$) or, more probably, by an erroneous value of the microchannel diameter. Error bars considering an uncertainty of 0.01mm in the measurement of the microchannel diameter are presented. It is possible to observe how this uncertainty on the microchannel alone influences significantly the results. At the present moment the diameter value of the microtube used is being inspected with optical measurement techniques.

From the Maxwell-slip model (Karniadakis *et al.*, 2005), it is possible to see that smaller tangential accommodation coefficients are related to higher slip velocities and, consequently, higher mass flow rates. This can be seen in Figure 6 where the higher values of the non-dimensional mass flow rate for same rarefaction of the gas correspond to a specular-diffuse molecular reflection at the wall ($\sigma = 0.8$), while the lower values correspond to a complete diffuse molecular reflection at the wall ($\sigma = 1$).

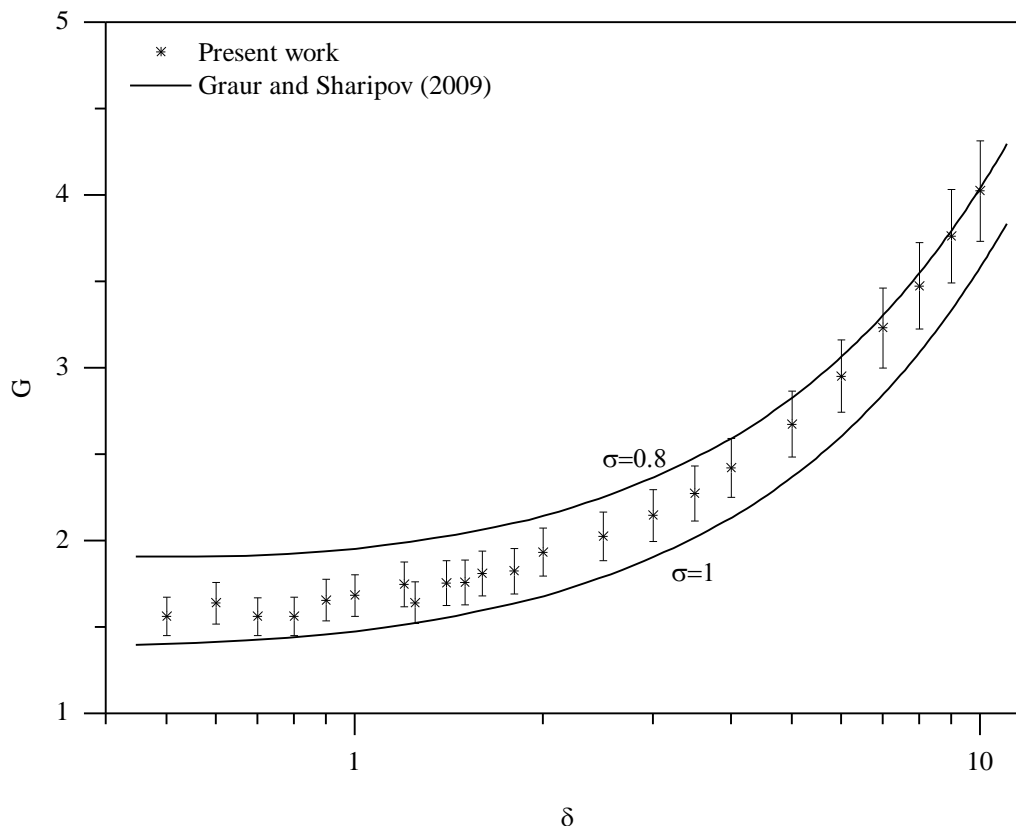

Figure 6: Comparison against theoretical data

4. CONCLUSIONS

An experimental setup for the measurement of mass flow rates of gases through microtubes was developed based on the constant-volume technique. Results for flows of nitrogen in a cylindrical microtube with 0.42mm of nominal diameter were compared with theoretical data and a good agreement was observed. A constant offset between the experimental and theoretical data was attributed to an incomplete accommodation of the gas at the walls or, more probably, to an imprecise value of the microtube diameter. In the future the authors are preparing experiments to be performed with refrigeration fluid through microchannels with different cross-sections. Experimental results obtained with this setup might be used for the validation of a previously existing numerical model developed in-situ for the leakage of refrigerant between valve and seat of compressors.

NOMENCLATURE

G	reduced flow rate	(–)
l	characteristic dimension	(m)
L		
m	mass of gas	(kg)
Kn	Knudsen number	(–)
P	pressure	(Pa)
R	microtube radius	(m)
t	time	(s)
T	temperature	(K)
δ	rarefaction parameter	(–)
λ	mean free path	(m)
μ	viscosity	(kg/m-s)
σ	accommodation coefficient	(–)
τ	tangential momentum	(N-s)
\mathfrak{R}	specific gas constant	(J/kg-K)

Subscript

$down$	downstream
up	upstream
m	mean
i	incident
r	reflected
w	wall

REFERENCES

- Arkilic, E.B., Schmidt, M.A., Kenneth, S.B., 1997, Gaseous Slip Flow in Long Microchannels, *J Microelectromech Syst*, vol. 6, no. 2: p. 167–178.
- Karniadakis, G., Beskok, A., Aluru, N., 2005, *Microflows and Nanoflows Fundamentals and Simulation*, Springer, New York, 816 p.
- Bird, G.A., 1994, *Molecular Gas Dynamics and the Direct Simulation of Gas Flows*, Oxford University Press, New York, 458 p.
- Colin, S., Lalonde, P., Caen, R., 2004, Validation of a Second-Order Slip Flow Model in Rectangular Microchannels, *Heat Transfer Eng*, vol. 25, no. 3: p. 23–30.
- Ewart, T., Perrier, P., Graur, I., Méolans, J.G., 2006, Mass flow rate measurements in gas micro flows, *Exp. Fluids*, vol. 41, no. 3: p. 487–498.
- Jang, J., Wereley, S.T., 2004, Pressure distributions of gaseous slip flow in straight and uniform rectangular microchannels, *Microfluid Nanofluid*, vol. 1, no. 1: p. 41–51.
- Sharipov, F.M., Graur, I., 2009, Non-isothermal flow of rarefied gas through a long pipe with elliptic cross section, *Microfluid Nanofluid*, vol. 6, no. 2: p. 267–275.
- Silva, L.R., Deschamps, C.J., 2012, Modeling of Gas Leakage through Compressor Valves, *Proc. Int. Compressor Engineering Conference at Purdue*, 1344.

ACKNOWLEDGEMENTS

The authors would like to express their gratitude to the invaluable support of Professor Walter L. Weingaertner in providing the microchannel used in the experiments. The present study was developed as part of a technical-scientific cooperation program between the Federal University of Santa Catarina and EMBRACO. The authors also thank CNPq (National Council of Research) and CAPES (Coordination for the Improvement of High Level Personnel) for the financial support.