

Purdue University
Purdue e-Pubs

International Compressor Engineering Conference

School of Mechanical Engineering

2014

A Study on PWM Bypass Capacity Control of Scroll Compressors

Ryota Iijima

Hitachi, Ltd., Japan, ryota.ijima.nj@hitachi.com

Masaki Koyama

Hitachi, Ltd., Japan, masaki.koyama.pg@hitachi.com

Follow this and additional works at: <https://docs.lib.purdue.edu/icec>

Iijima, Ryota and Koyama, Masaki, "A Study on PWM Bypass Capacity Control of Scroll Compressors" (2014). *International Compressor Engineering Conference*. Paper 2341.

<https://docs.lib.purdue.edu/icec/2341>

This document has been made available through Purdue e-Pubs, a service of the Purdue University Libraries. Please contact epubs@purdue.edu for additional information.

Complete proceedings may be acquired in print and on CD-ROM directly from the Ray W. Herrick Laboratories at <https://engineering.purdue.edu/Herrick/Events/orderlit.html>

A Study on PWM Bypass Capacity Control of Scroll Compressors

Ryota IIJIMA^{1*}, Masaki KOYAMA¹

¹Hitachi, Ltd., Hitachi Research Laboratory,
Hitachinaka, Ibaraki, Japan
ryota.iijima.nj@hitachi.com

* Corresponding Author

ABSTRACT

A pulse width modulation (PWM) bypass capacity control technique for air conditioners has been developed to achieve high scroll compressor efficiency over a wide capacity range, and we investigated the technique's fundamental characteristics in this study. With this capacity control technique, the refrigerant flow rate is controlled by periodically switching a full load mode, in which the refrigerant is compressed and discharged out of the compressor, and an unload mode, in which the refrigerant is not compressed so that the power needed to compress is unnecessary. In this study, we measured the pressure and input power of a compressor using the control technique to clarify the technique's dynamic characteristics. We also developed a numerical simulation model to predict the dynamic behavior of the refrigerant. The calculated pressures were found to be in good agreement with the measured pressures and were used to estimate the relation between the PWM period and the efficiency or the discharge flow rate. Since the PWM period could not be determined by the demanded load capacity, the estimations were used to determine it. Using this period, we carried out performance tests of a compressor with PWM bypass capacity control. The results showed the capacity reached 30% of the lower limit of rotational speed and that the calculated efficiencies agreed well with the experimental findings.

1. INTRODUCTION

Recently, air conditioning systems have been required to achieve higher efficiency at lower heat loads as well as at the higher heat loads conventionally considered to be important, since such systems have been operated more frequently at lower loads in actual use. In other words, it is an important issue to enhance the efficiency over a wider heat load range. In particular, since compressors consume most of the power in an air conditioning system, it is desirable to enlarge the capacity control range and to enhance efficiency. Whereas the capacity can be controlled by changing the number of compressors in a large system, capacity control techniques of a single compressor are applied in a small system.

The most common control technique for a single compressor is using an inverter to vary the motor rotational speed; the speed is reduced when a lower load is required. Furthermore, when the heat load is lower than that corresponding to the lower limit of the speed, the motor is intermittently stopped to reduce the capacity. However, stopping the motor breaks down the balance of the refrigerating cycle and significantly decreases the system efficiency.

To overcome the problem, Koyama *et al.* (2012) developed a mechanical capacity control technique, in which the compressor periodically operates in an unload mode, where the compressor stops compressing the refrigerant with its rotational speed maintained. By using this technique, Koyama *et al.* demonstrated that the developed compressor could reduce its capacity to 3% load.

Yoshida *et al.* (2013) applied this technique to an air conditioning system compressor along with the technique of natural refrigerant circulation, and test results confirmed they had achieved annual efficiency 1.51 times higher than that of current systems.

In this study, we defined the control technique used by Koyama *et al.* (2012) as “PWM (Pulse Width Modulation) bypass capacity control” and investigated it in detail. First, we investigated the technique’s fundamental characteristics by measuring pressure and power. We then developed a calculation model for the refrigerant behavior and used the calculation results to determine the control parameters. Finally, the parameters were used in carrying out performance tests.

2. METHODS

2.1 PWM Bypass Capacity Control

Figure 1 shows the structure of the scroll compressor used in this study. The characteristic structure for the capacity control is as follows: a discharge cover is placed on the fixed scroll and a bypass chamber is created between the discharge cover and the fixed scroll. The enlarged view around the bypass chamber is shown in Figure 2. The bypass chamber is connected to the suction pipe via the bypass pipe and to the discharge chamber through the discharge valve. The solenoid valve controlled by an input signal is set in the bypass pipe.

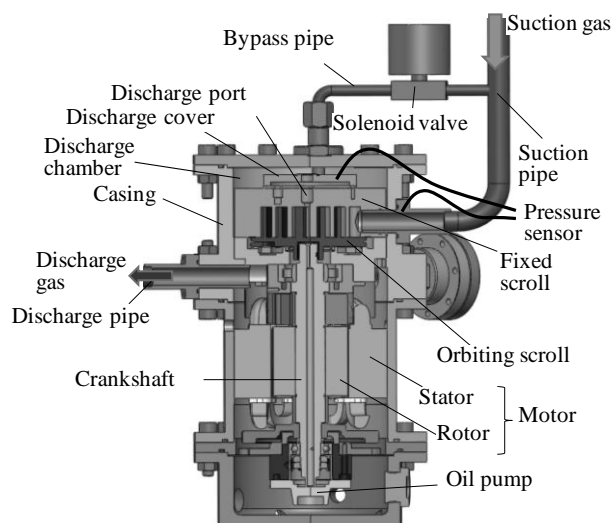

Figure 1: Experimental compressor

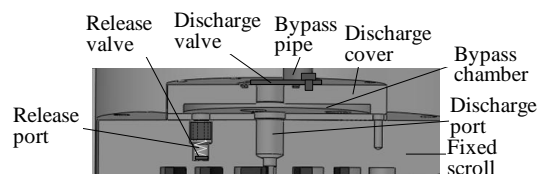

Figure 2: Enlarged view around bypass chamber

Figures 3 and 4 depict the mechanism of the PWM bypass capacity control. In the control, a full load mode (Figure 3) and an unload mode (Figure 4) are alternately switched by closing and opening the solenoid valve.

In the full load mode, the compressor compresses the gas as usual, with the solenoid valve closed and the bypass pipe shut off. The compressed gas is discharged to the bypass chamber. Then, if the pressure of the bypass chamber is higher than that of the discharge chamber, the discharge valve is opened due to the pressure difference between the two chambers, and the gas is finally discharged out of the compressor through the discharge chamber and the discharge pipe.

The unload mode works as follows. When the solenoid valve is opened, the bypass chamber is connected to the suction pipe through the bypass pipe, thus reducing the bypass chamber pressure to the suction pressure. Consequently, when an attempt is made to compress the gas in the compression chambers, the release valves placed between the compression and bypass chambers are opened so that the gas is discharged to the bypass chamber with no compression and circulated to the suction pipe through the bypass pipe.

Figure 5 illustrates how the capacity is controlled by the PWM control. This figure shows the time-varying discharge flow rate of the compressor with the PWM bypass capacity control. In this control, a full load mode where the compressed gas is discharged and an unload mode where the gas is not compressed are switched periodically in order to control the averaged discharge flow rate by adjusting the time ratio of these two modes. Therefore, the duty ratio, which is defined as the ratio of the unload mode time to the PWM period, is a parameter of the control technique. The duty ratio is determined by the required capacity. In contrast, since the PWM period is independent of the required capacity, it needs to be determined by another criterion. There are two specific parameters of the PWM bypass capacity control: the duty ratio and the PWM period.

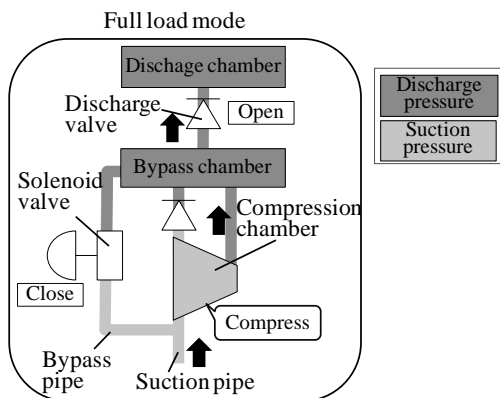

Figure 3: Schematic diagram of PWM bypass capacity control's full load mode

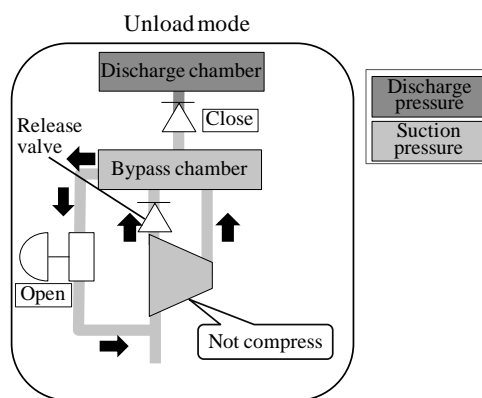

Figure 4: Schematic diagram of PWM bypass capacity control's unload mode

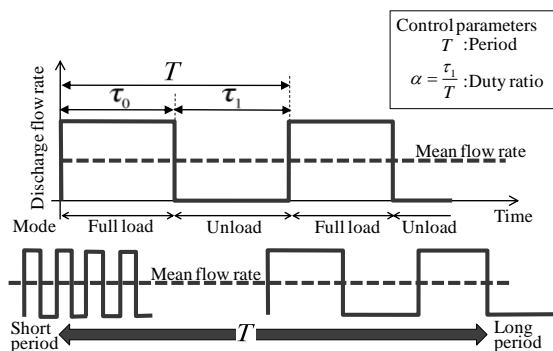

Figure 5: Control method of discharge flow rate

2.2 Experiment

In this study, time-varying pressures of the bypass chamber and the suction pipe were measured as shown in Figure 1 in order to understand the dynamic behavior of the mode change. The power inputs of the inverter and the compressor were also measured.

The efficiency was also measured to evaluate the performance of the capacity control technique. In this measurement, the overall efficiency, defined as the ratio of the effective power to the input power of the inverter, is used as an evaluation factor.

In all experiments, HFC-134a was used as the refrigerant.

2.3 Numerical Simulation

To estimate the loss caused by the mode switching and to determine the control parameters, we developed a numerical simulation model (Figure 6) that can calculate the dynamic behavior of the refrigerant with the PWM bypass capacity control. This model is a one-dimensional simulator and actually comprises two types of models: chamber models, which contain the refrigerant, and flow models, which connect two chambers through which the

gas can flow from one to the other. Each chamber model is assigned a thermodynamic state, while each flow model calculates the flow rate from the pressure difference between the adjacent chambers.

The loss caused by the gas flow can be estimated by using this simulator. The bypass efficiency η , which was used as an evaluation index, is defined as follows.

$$\eta \equiv G(h_b - h_s) / G_c(h_c - h_s) \quad (1)$$

where G and G_c are the respective flow rates through the discharge valve and the compression chamber, and h_s , h_b , and h_c are the specific enthalpy of the refrigerant in the suction chamber, the bypass chamber, and the compression chamber, respectively.

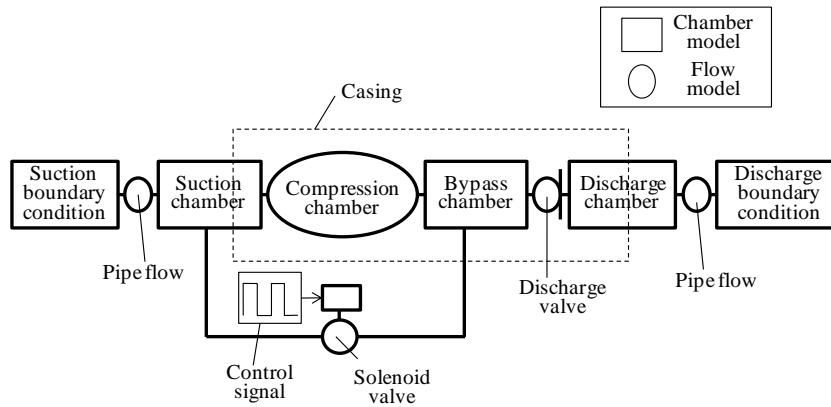

Figure 6: Simulation model for PWM bypass capacity control

3. RESULTS

3.1 Measurement of Input Power and Pressure

Figures 7 and 8 show the measurement results of input power and pressure. In Figure 7, the vertical axis represents input power normalized by the averaged inverter input power in the full mode, and the horizontal axis represents elapsed time where a certain moment is defined as zero. The experimental conditions are as shown in Table 1.

In the figure, we can see that the input power of the inverter and the compressor increases in the full load mode (because the gas is compressed), whereas it decreases in the unload mode. Nevertheless, some amount of input power is actually needed even in the unload mode with no compression. The input power is totally consumed as loss, which includes pressure loss at the bypass pipe, the solenoid valve, and the release valves, and mechanical loss, such as friction loss. Actually, as Figure 8 shows, there is a pressure difference of about 30 kPa between the bypass chamber and the suction pipe in the unload mode.

In the full mode, on the other hand, the input power increases with time. This is because, as Figure 8 shows, in this mode the suction pressure decreases and the pressure difference between the bypass chamber pressure and the suction pressure increases gradually. In fact, Figure 7 shows that the theoretical adiabatic power, calculated from the pressure difference and the rotational speed, increases monotonically in the full mode. The pressure variation is caused by the compressor blocking the circulation of the gas in the air conditioning cycle in the unload mode.

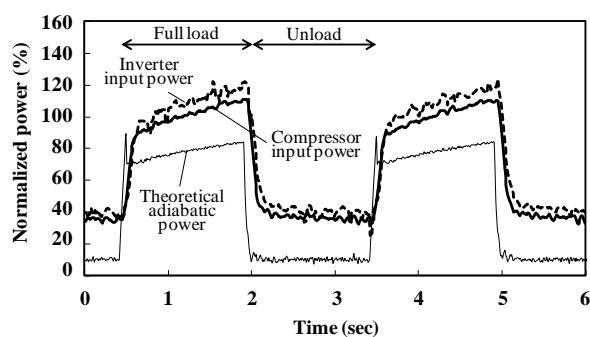

Figure 7: Measured input power and theoretical adiabatic power normalized by mean inverter power input

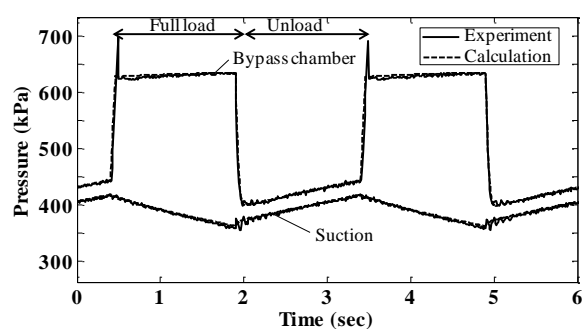

Figure 8: Bypass chamber/suction pressure

Table 1: Experimental conditions

Suction pressure	389 kPa
Discharge pressure	623 kPa
Rotational speed	15 sec ⁻¹
Duty ratio	50%
PWM period	3 sec

3.2 Evaluating Effects of Control Parameters

As mentioned in 2.1, the PWM bypass capacity control has two specific parameters: the duty ratio and the PWM period. The duty ratio is determined by the required power and the rotational speed, whereas the PWM period can be an arbitrary value. Nevertheless, too long a period gives rise to amplification of the pressure variation mentioned in the preceding subsection, so that the air conditioning cycle becomes more difficult to control. On the other hand, too short a period leads to increased switching loss due to the increased frequency of the mode switching. Figure 9 shows the detailed pressure variation at mode switches. The pressure varies with time delay, which means that the bypass chamber is considered a dead volume where the gas is compressed and expanded repeatedly.

In this study, we performed numerical simulations to estimate the loss caused by the PWM bypass capacity control. The results showed the calculated pressure agrees well with the pressure obtained in the experiment (Figures 8, 9).

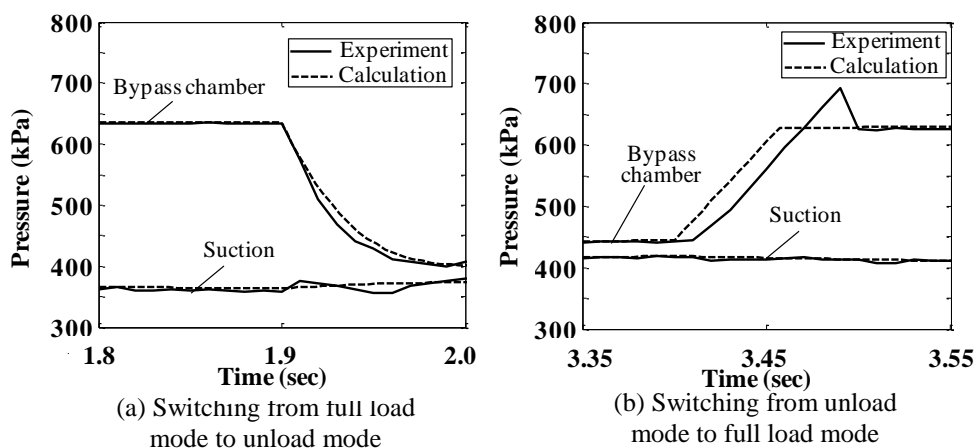

Figure 9: Comparison of measured and calculated pressure variation

Figure 10 shows the calculation results for the discharge flow rate versus the PWM period, where the flow rate is normalized by the flow rate at a duty ratio of 0%. The results show the flow rate converges to the corresponding

duty ratio as the PWM period increases, but that it drops sharply as the period decreases. This is because the discharge is delayed due to pressure variation delay in the bypass chamber and the discharge delay has greater effects at a shorter PWM period.

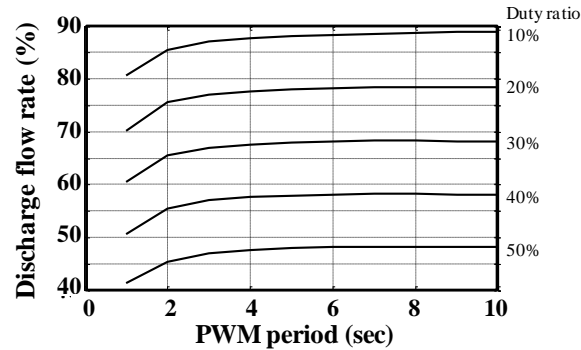

Figure 10: Effects of PWM period on discharge flow rate

The calculation results for the bypass efficiency (Equation 1) are shown in Figure 11. The bypass efficiency includes pressure drop in the bypass flow path and re-expansion loss. The figure shows the bypass efficiency drops sharply at a shorter PWM period, in the same way as the flow rate (Figure 10). The bypass efficiency decreases with the duty ratio, which is explained by the following three causes: as the duty ratio increases, (1) the required compression power decreases, (2) the re-expansion loss remains as a fixed loss, i.e., the loss is independent of the duty ratio, and (3) loss in the unload mode increases since the time span of this mode becomes longer.

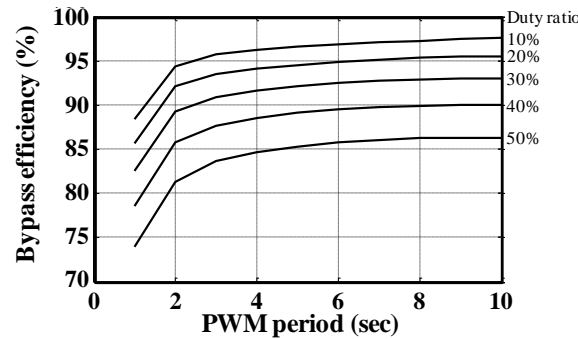

Figure 11: Effects of PWM period on bypass efficiency

After considering these results and an acceptable value for the pressure variation in the air conditioning cycle that results from switching the modes, we set the PWM period to 6 sec and used this period in conducting a performance test, as described in the following subsection.

Since we considered that decreasing the bypass chamber volume would result in reduced re-expansion loss, we calculated the relation between the volume and the bypass efficiency. The results are shown in Figure 12, where the dashed lines indicate the extrapolations of the data calculated for PWM periods of 3 sec and 6 sec. The results for both periods show that the bypass efficiency increases as the volume becomes smaller. They also show that for both periods the efficiency converges to the same value at zero volume. Because the limit of the re-expansion loss must be zero as the volume approaches zero, the loss at zero volume is caused by the pressure drop.

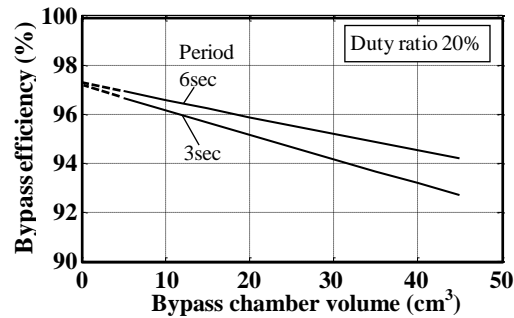

Figure 12: Effects of bypass chamber volume on bypass efficiency

3.3 Performance Tests

Figure 13 shows experiment results on the overall efficiency obtained when using the PWM bypass capacity control, where the capacity is controlled by a combination of the rotational speed and the duty ratio. The overall efficiency includes the inverter efficiency and is normalized by the overall efficiency at a rotational speed of 20 sec^{-1} and a duty ratio of 0%. The test conditions we used are shown in Table 2. The lower limit of the rotational speed where the compressor used in this study can operate continuously is 10 sec^{-1} .

From the figure, it can be seen that at 15 sec^{-1} rotational speed the capacity is reduced as the duty ratio increases, and that at a duty ratio of 60% it drops to about 230 W, which is 6% of the rated cooling capacity (4 kW). That capacity corresponds to 3 sec^{-1} rotational speed, which demonstrates that the compressor using the PWM bypass capacity control can operate continuously at 30% of the lower limit of the rotational speed. The overall efficiency, however, decreases to around 40%. Then the rotational speed was decreased and the duty ratio increased while maintaining the capacity at the same value corresponding to 3 sec^{-1} , and the overall efficiency was enhanced to 60% at 10 sec^{-1} and a duty ratio of 45%. It is considered that reducing the speed enables enhanced efficiency because the drop in speed reduces both the pressure drop in the bypass flow path and mechanical loss. Hence, with the PWM bypass capacity control it is preferable for the compressor to operate at as low a speed as possible, at least under the conditions applied in this study.

Figure 13 also shows the calculation results obtained as dashed lines. The results agree comparatively well with the experiment results, demonstrating that the efficiency prediction process is effective.

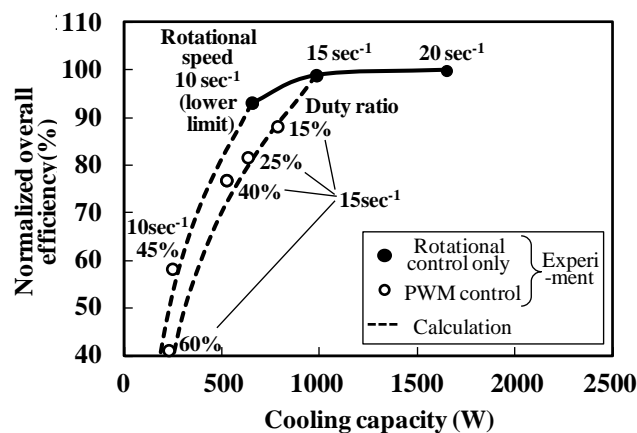

Figure 13: Overall efficiency of scroll compressor using PWM bypass capacity control compared with only rotational capacity control

Table 2: Experimental conditions

Suction pressure	351 kPa
Discharge pressure	623 kPa
Suction temperature	20.1 °C
PWM period	6 sec

4. CONCLUSION

In this study, we investigated a pulse width modulation (PWM) bypass capacity control technique by developing a capacity control technique enabling a compressor to achieve high efficiency over a wide heat load range, a prototype compressor, and a calculation simulator and using them to examine the technique's characteristics.

First, we used measured pressure and input power variations to show that a compressor using PWM bypass capacity control has specific loss factors, i.e., bypass pressure drop and re-expansion loss in the bypass chamber.

Second, the relations between the PWM period and the discharge flow rate or the bypass efficiency were clarified by using the developed simulator, which can reproduce the pressure obtained in the experiments and make it possible to determine an appropriate PWM period to be applied.

Finally, performance tests conducted using the determined PWM period showed that a compressor with the control technique can operate continuously at about 30% of the load corresponding to the lower limit of its rotational speed. In addition, the efficiency predictions obtained by the simulator were found to agree comparatively well with the experiment results.

REFERENCES

- Masaki Koyama *et al.*, 2012, Wide-range Scroll Compressor for Heat Pump System That Improves Annual Efficiency by Fitting the Actual Air-conditioning Load (in Japanese), *International Symposium on New Refrigerant and Environmental Technology*, JRAIA, pp. 130-133.
- Yasutaka Yoshida *et al.*, 2013, A Heat Pump System That Improves Annual Efficiency by Fitting the Actual Air-conditioning Load (in Japanese), *2013 JSRAE Conference*, JSRAE, pp. 563-566.