

Purdue University
Purdue e-Pubs

International Compressor Engineering Conference

School of Mechanical Engineering

2014

Analysis And Experimental Validation Of Structure-Borne Noise From Acoustic Enclosure Of Compressor

Satish Konderao Deshmukh

Kirloskar Pneumatic Company Limited, India, desh mukhsk@kpcl.net

Onkar Sunil Madhekar

Sinhgad College Of Engineering, Pune, India, madhekaronkar007@gmail.com

Follow this and additional works at: <https://docs.lib.purdue.edu/icec>

Deshmukh, Satish Konderao and Madhekar, Onkar Sunil, "Analysis And Experimental Validation Of Structure-Borne Noise From Acoustic Enclosure Of Compressor" (2014). *International Compressor Engineering Conference*. Paper 2276.
<https://docs.lib.purdue.edu/icec/2276>

This document has been made available through Purdue e-Pubs, a service of the Purdue University Libraries. Please contact epubs@purdue.edu for additional information.

Complete proceedings may be acquired in print and on CD-ROM directly from the Ray W. Herrick Laboratories at <https://engineering.purdue.edu/Herrick/Events/orderlit.html>

Analysis & Experimental Validation of Structure-Borne Noise from Acoustic Enclosure of Compressor

Satish DESHMUKH^{1*}, Onkar MADHEKAR²

¹Kirloskar Pneumatic Co. Ltd,
Pune, Maharashtra, INDIA
919881495518, desh mukhsk@kpcl.net

²Sinhgad College of Engineering,
Pune, Maharashtra, INDIA
919423244687, madhekaronkar007@gmail.com

* Corresponding Author

ABSTRACT

In this paper, acoustic enclosure for a compressor package is designed and an approach for Transfer Path Analysis (TPA) is proposed. Path Contribution and panel contribution can be seen for which path dominates over the structure. A method is presented to reduce noise by structural modifications of the enclosure. Guiding phenomenon was implemented to reduce the noise i.e. obstacles to the wave propagation were provided. The points where noise level (vibrations) was maximum, ribs and barriers were provided. The presented work can be used for similar problems involving structure-borne noise sources. The analysis work presented in the paper is done in NASTRAN.

1. INTRODUCTION

Noise is transmitted into a closed structure via two distinct paths: through air (air-borne noise) and through structure (structure-borne noise). These paths are primarily governed by the frequency of noise. Transfer path analysis is the best procedure which allows to trace the flow of Vibro-acoustic energy from a source to a given receiver location through a set of known structure-borne and air-borne paths. The purpose of transfer path analysis is to determine which paths are dominant in transmitting vibrations or noise from one or several sources to one or more receivers. Study consists of,

- Ranking of domination of path over the structure
- Computation of panel participation

2. LITERATURE REVIEW

Authors of LMS International (1997) described briefly about the measurement of transfer paths, operational body forces and body side Frequency Response Functions (FRFs). Haste and Nachimuthu (1998) made an assumption in TPA that the summation of all partial contributions from different paths constitutes the total response. They studied the effect of component sensitivity on total response i.e. output. Tandogan and Guney (2010) discussed about methods of identification of vehicle air-borne and structure-borne noise sources and noise transfer paths. Schwarz and Richardson (1999) discussed all the topics associated with experimental modal analysis (modal testing), FRF measurements, modal excitation techniques and modal parameter estimation from a set of FRFs. Jee *et al.* (2000) focused on how to get contribution of panel vibration. They found that, sensitive position of panel was found by applying reciprocity and also added mass to sensitive panel position. Lanslots (2012) gave overall information regarding Transfer Path Analysis.

3. ASSUMPTIONS

Some assumptions were made while carrying out whole test procedure and work:

- The vibration of panel is within prescribed limit.
- The effect of sound absorbing material is not considered.

4. MODELING OF STRUCTURE

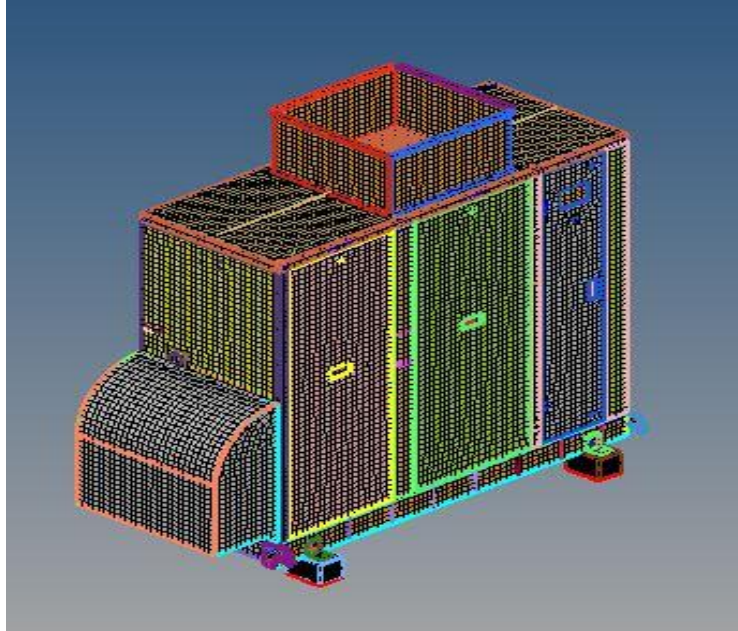

Figure 1: Meshed enclosure structure



Figure 2: Actual photograph of enclosure (test facility)

The detailed finite element model of enclosure structure was constructed by using 2D elements. The connections such as bolting, hinges, rivets, welding, etc. were shown by rigid elements, constraint elements and non-structural elements. Fine meshing is adopted for maximum degree of accuracy. Nearly 600000 nodes are present in the model.

5. CAVITY MODELING

The interior of canopy is resembled with rectangular volume which yields analytical solution for natural frequencies (in Hz) and acoustical modes as follows,

$$f_{ijk} = \frac{c}{2} \sqrt{\left(\frac{i}{L_x}\right)^2 + \left(\frac{j}{L_y}\right)^2 + \left(\frac{k}{L_z}\right)^2} \quad (1)$$

$$\psi_{ijk} = \cos \frac{i\pi x}{L_x} \cos \frac{j\pi y}{L_y} \cos \frac{k\pi z}{L_z} \quad (2)$$

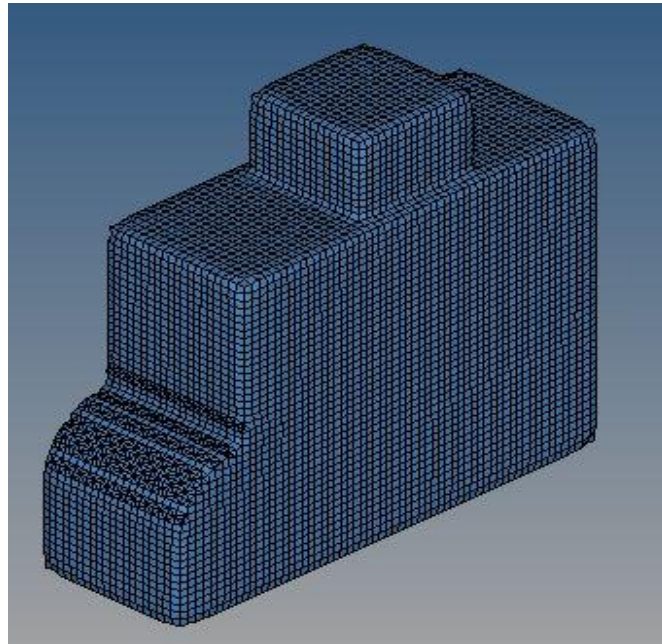

Figure 3: Acoustic cavity mesh

The cavity is modeled by solid elements which represent cavity volume. At low frequencies, it is important to manage modes so that cavity resonance frequencies are well separated from panel modes & compressor operating frequencies. Also, sometimes at higher frequencies, the interior acoustic field displays complex mode shapes.

6. CORRELATION OF VIBRATION & NOISE LEVELS

As known, estimation of structure-borne noise involves complex calculations with empirical and semi-empirical methods. Alten *et al.* (2010) gave the equation which links the sound power level to the structure-borne vibration velocity,

$$L_w = \overline{L_v} + \left[10 \log \frac{S}{S_0} + 10 \log \sigma + 10 \log \frac{\rho c}{(\rho c)_0} \right] \quad (3)$$

7. MODAL ANALYSIS OF THE STRUCTURE

Modes are inherent properties of the structure and are determined by the material properties and boundary conditions of the structure. It allows the design to avoid resonant vibrations or to vibrate at specified frequency.

The free-free run of the structure is carried out to see whether all the connections are done properly or not. If the connections are not proper, then the panel or that structural part moves away from its prescribed position. First five modes of the modal analysis results are taken. The plots showed that the whole connections are proper and not a single part of the structure moves from its position.

The combination of design approaches of Statistical Energy Analysis (SEA) and Finite Element Analysis (FEA) can be used to deal with high/high or low/low frequency of the structure and modal density problems.

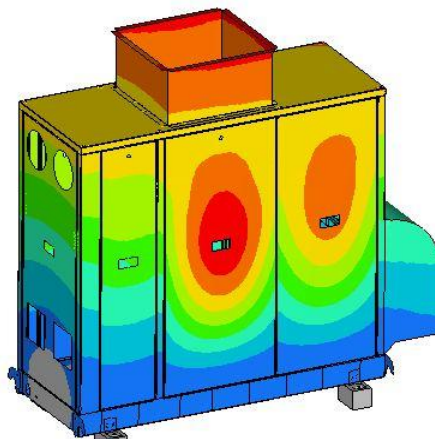

Figure 4: 1st mode

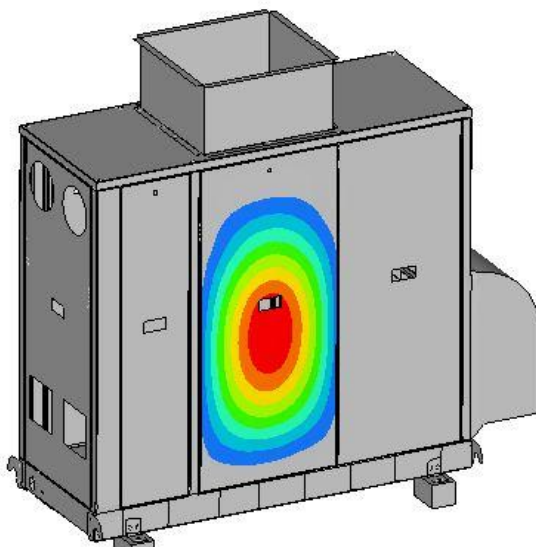

Figure 5: 2nd mode

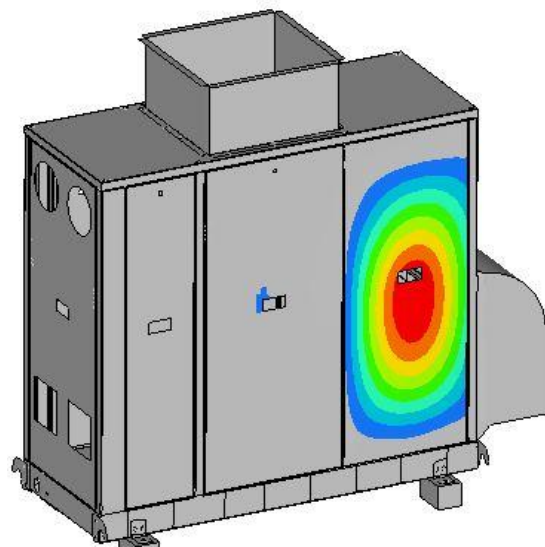

Figure 6: 3rd mode

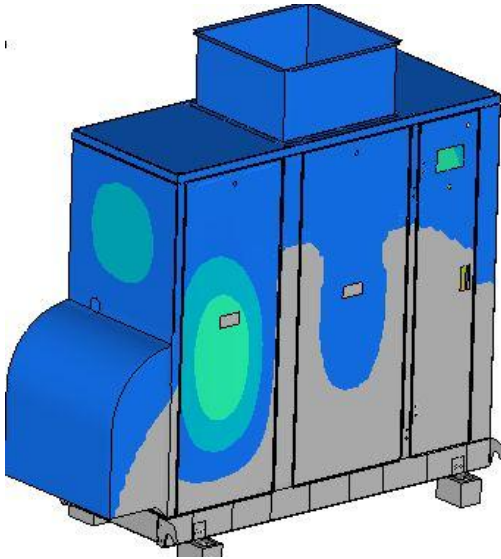

Figure 7: 4th mode

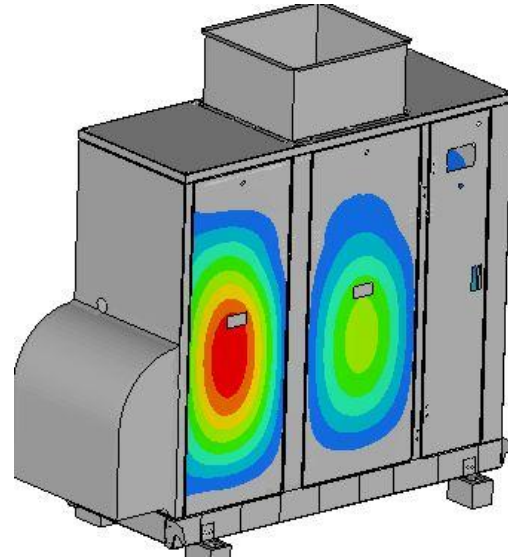

Figure 8: 5th mode

From the above Figures 4, 5, 6, 7 and 8, it is observed that in the red portion region there is no connection of the panel to the structural members. Also we can see the proper connections present on the upper side of the panel. Connectivity also exists on sideways and lower portion of the panel. Table No. 1 shows no. of modes extracted & respective natural frequencies.

Table 1: Modes extracted

Mode No.	Natural Frequency (Hz)
1	11.73
2	16.631
3	18.161
4	20.066
5	20.375

8. ANALYSIS PROCEDURE

Analysis of the structure carried in NASTRAN. The response can be measured at desired points. Authors proposed a guiding phenomenon in which ribs & barriers should be provided at the points where noise level is found to be maximum. They should be designed and fixed to the two different locations. One where noise level is found to be maximum and another point is closest fixed point of the enclosure structure. A simulation model can be made like actual enclosure structure with all properties. The data measured at response locations in actual can be tallied by results obtained in software simulation.

The procedure should be performed until experimental data fairly matches with the analysis data.

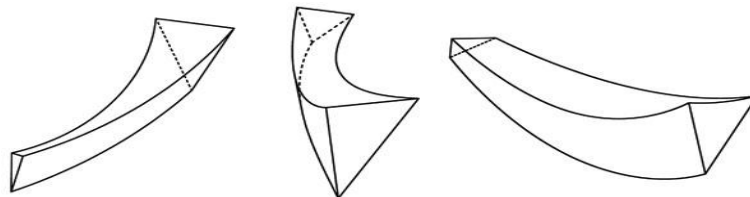

Figure 9: Various types of ribs to be added in structure

8.1 Detailed procedure:

Readings were taken both for noise level (one-third octave bands) and vibrations at different locations. The locations were decided by free (modal) analysis.

Nastran, SOL 103 is a control card used for modal analysis. The model is included in the deck file. EIGRL control card is used for giving frequency range for performing modal analysis. The frequency domain has been considered here for analysis purpose. ACMODL card is used to show acoustic-fluid structure interaction.

9. VIBRATION READINGS

The vibration responses were taken at some particular locations considering the modal analysis like on structural members of enclosure, on panels and some points on ducts etc.

Figures 10, 11, 13 and 14 show that the vibrations are more, with the peak value upto 0.7 m/s^2 , as they are closely connected to structural members of enclosure. The vibrations on exhaust duct (shown in Figure 12) are comparatively less with the maximum value 0.1 m/s^2 . As readings were taken at locations where there were no connections in the proximity of panel to enclosure structure.

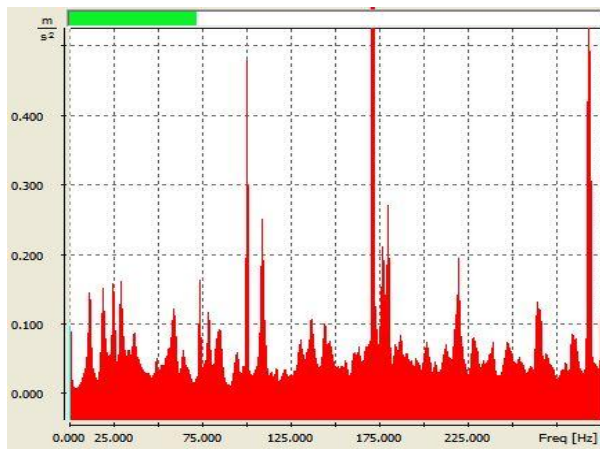

Figure 10: On enclosure structural member (location 1)

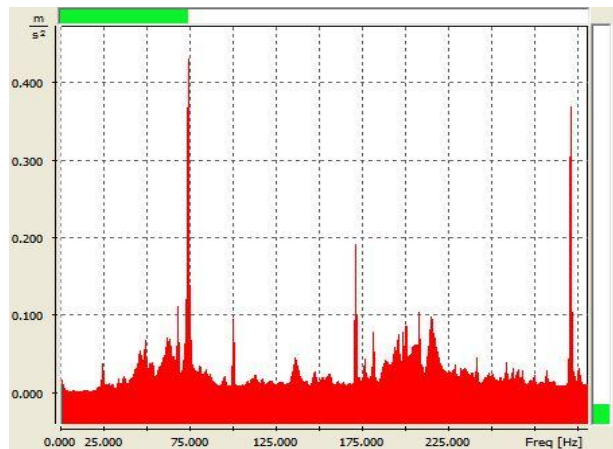

Figure 11: On middle panel (location 2)

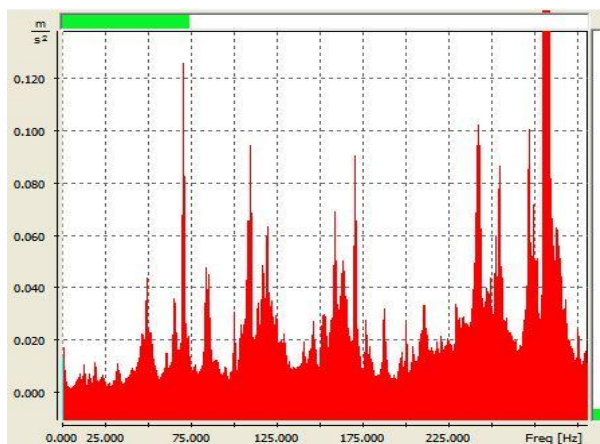

Figure 12: On exhaust duct (location 3)

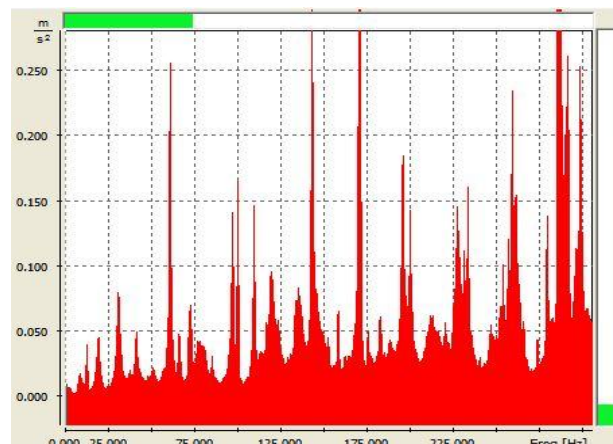

Figure 13: On suction duct (location 4)

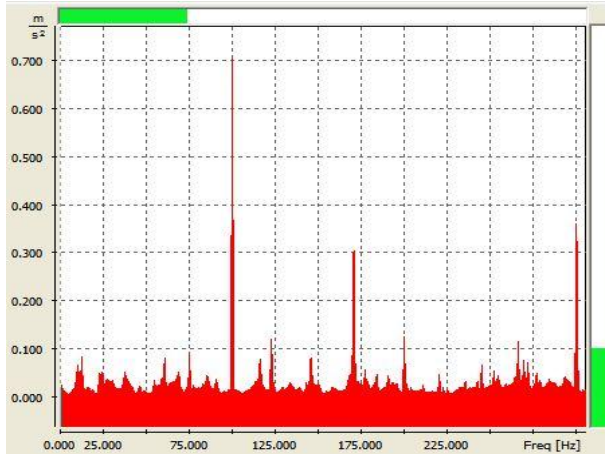

Figure 14: On back panel (location 5)

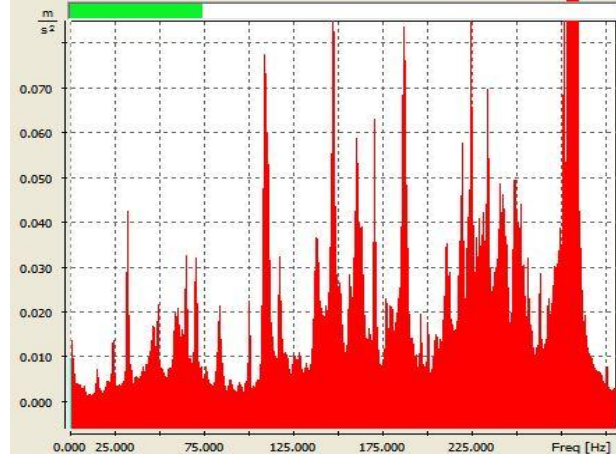

Figure 15: On side panel (location 6)

In case of side panel (Figure 15), responses are within 0.1m/s^2 .

Above analysis gives indication about the locations where structural rigidity needs to be provided.

10. RESULTS & DISCUSSIONS

10.1 Panel Participation Analysis

Panel Participation Analysis techniques are used to investigate how different panels and leaks contribute to sound field at specific locations. The contribution of the panels can be seen in HyperView for the response locations.

10.2 Structural Modal Participation Factor Analysis

The displacement of the structure is a summation of each mode displacement. Modal Participation Factor represents participation of mode. Modifications done in most of the participating mode shape have greatest effect on the noise level. It is carried out to identify dominant modes that contribute to noise at specific frequency.

11. CONCLUSION

Some panels of the structure contribute their effect on noise. They are taken for further analysis. Modifications can be carried out at these locations with the reinforcement of ribs. Again the analysis can be carried out. The process should be carried out till noise-vibrations came in the prescribed limit. The CAE and the experimental results show a fair correlation. After corrective actions, due to increased structural rigidity at specific required locations (identified through analysis), the structure borne-noise & sound pressure level (SPL) can be reduced.

Even European standard EN12345-5 has admitted that “structure-borne noise sources and transmission are not completely understood”. The absolute values or the results of this experimentation and analysis are not important. However, the approach/methodology presented herein is innovative and can further be strengthened.

NOMENCLATURE

f	Natural frequency	(Hz)
ψ	Acoustic modes	(-)
L_x, L_y, L_z	Lengths across panel	(m)
i, j, k	No. of modes of vibration	(-)
c	Sound velocity	(m/s)
L_w	Sound power level	(dB)

$\overline{L_v}$	Vibration velocity level averaged over time and plate area, reference $v_0 = 5 \times 10^{-8} \text{ m/s}$	(dB)
S	Surface area of radiating plate, S_0 as reference surface area [1 m ²]	(m ²)
σ	Radiation efficiency of plate	(-)
ρ	Air density	(kg/m ³)
$(\rho c)_0$	Characteristic acoustic impedance of air (420 Ns/m ³ at 20 ^o C)	(Ns/m ³)

REFERENCES

- Alten, K., *et al*, 2010, Calculating Ground-Borne Noise From From Ground-Borne Vibration- A Comparison of Different Approaches, Proceedings of ISMA 2010, Railway Dynamics & Ground Vibrations.
- Bennur, M., et al, 2014, Web Seminar on Transfer Path Analysis at General Motors.
- Duncan, A., Govindswamy, K., 2011, SAE NVH Conference, Structure Borne NVH Workshop.
- Haste, F., Nachimuthu, A., 1998, Calculating Partial Contribution Using Component Sensitivity Values: A Different Approach to Transfer Path Analysis Proceedings of the 1999 Noise and Vibration Conference, SAE Paper No. 1999-01-1693.
- Janssens, K., Mas, P., et al, 2009, A Novel Transfer Path Analysis Method Delivering a Fast and Accurate Noise Contribution Assessment, SAE Paper No. 2009-26-047.
- Jee, S., Park, J., et al, 2000, Panel Contribution Analysis by using Acoustic Reciprocity, Second Worldwide Automotive Conference International Journal of Acoustics and Vibration, Dearborn, Michigan, 10-14 October.
- Lanslots, J., 2012, Web Seminar Fundamentals of Transfer Path Analysis, LMS International.
- LMS International, 1997, Transfer Path Analysis: The Qualification and Quantification of Vibro-acoustic Transfer Paths, www.lmsintl.com, pp. 1-2.
- Sanderson, M., Onsay, T., 2007, CAE Interior Cavity Model Validation using Acoustic Modal Analysis, SAE Paper No. 2007-01-2167.
- Schwarz, Brian J., Richardson, Mark H., 1999, Experimental Modal Analysis, Vibrant Technology Inc., Jamestown, California 95327, pp. 1-12.
- Singh, R., Kim, S., 2005, Prediction of Structure-borne Noise Transmission through Multiple/Multi-Dimensional Transfer Paths, Key Note Lecture.
- Tandogan, F., Guney, A., 2010, Vehicle Interior Noise Source Contribution and Transfer Path Analysis, International Journal of Vehicle Design, Volume 52, Nos. 1/2/3/4, 2010, pp. 252-267.

ACKNOWLEDGEMENT

Special thanks to Mr. Vivek Hanchate & Mr. Sahil Pandare employees of Tata Technologies & Tata Motors and for their guidance throughout the work. Also we would like to thank Mr. Rajesh Askhedkar of Kirloskar Oil Engines, Pune and Mr. Pankaj Aher of Whirlpool Corporation for their valuable guidance. We are thankful for the help in the work from Prof. S.B. Sanap of Sinhgad College of Engineering, Pune.