

12-2010

Performance Evaluation of Brass Breakaway Couplings

Joseph G. Putjenter

University of Nebraska-Lincoln, jputjenter@gmail.com

Scott K. Rosenbaugh

University of Nebraska - Lincoln, srosenbaugh2@unl.edu

Karla A. Lechtenberg

University of Nebraska - Lincoln, kpolivka2@unl.edu

Ronald K. Faller

University of Nebraska - Lincoln, rfaller1@unl.edu

Dean L. Sicking

University of Nebraska - Lincoln, dsicking1@unl.edu

See next page for additional authors

Follow this and additional works at: <http://digitalcommons.unl.edu/ndor>



Part of the [Transportation Engineering Commons](#)

Putjenter, Joseph G.; Rosenbaugh, Scott K.; Lechtenberg, Karla A.; Faller, Ronald K.; Sicking, Dean L.; and Reid, John D., "Performance Evaluation of Brass Breakaway Couplings" (2010). *Nebraska Department of Transportation Research Reports*. 96. <http://digitalcommons.unl.edu/ndor/96>

This Article is brought to you for free and open access by the Nebraska LTAP at DigitalCommons@University of Nebraska - Lincoln. It has been accepted for inclusion in Nebraska Department of Transportation Research Reports by an authorized administrator of DigitalCommons@University of Nebraska - Lincoln.

Authors

Joseph G. Putjenter, Scott K. Rosenbaugh, Karla A. Lechtenberg, Ronald K. Faller, Dean L. Sicking, and John D. Reid



TESTING CERT # 2937.01

*Midwest States Regional Pooled Fund Research Program
Fiscal Year 2009-2010 (Year 20)
Research Project Number TPF-5(193)
NDOR Sponsoring Agency Code RFPF-10-POLE*

PERFORMANCE EVALUATION OF BRASS BREAKAWAY COUPLINGS

Submitted by

Joseph G. Putjenter
Undergraduate Research Assistant

Scott K. Rosenbaugh, M.S.C.E., E.I.T.
Research Associate Engineer

Karla A. Lechtenberg, M.S.M.E., E.I.T.
Research Associate Engineer

Ronald K. Faller, Ph.D., P.E.
Research Assistant Professor

John D. Reid, Ph.D.
Professor

Dean L. Sicking, Ph.D., P.E.
Professor and MwRSF Director

MIDWEST ROADSIDE SAFETY FACILITY

Nebraska Transportation Center
University of Nebraska-Lincoln
2200 Vine Street
130 Whittier Research Center
Lincoln, Nebraska 68583-0853
(402) 472-0965

Submitted to

MIDWEST STATES REGIONAL POOLED FUND PROGRAM

Nebraska Department of Roads
1500 Nebraska Highway 2
Lincoln, Nebraska 68502

MwRSF Research Report No. TRP-03-248-10

December 22, 2010

TECHNICAL REPORT DOCUMENTATION PAGE

1. Report No. TRP-03-248-10	2.	3. Recipient's Accession No.	
4. Title and Subtitle Performance Evaluation of Brass Breakaway Couplings		5. Report Date December 22, 2010	
		6.	
7. Author(s) Putjenter, J.G., Rosenbaugh, S.K., Lechtenberg, K.A., Faller, R.K., Reid, J.D., and Sicking, D.L.		8. Performing Organization Report No. TRP-03-248-10	
9. Performing Organization Name and Address Midwest Roadside Safety Facility (MwRSF) Nebraska Transportation Center University of Nebraska-Lincoln 2200 Vine Street 130 Whittier Research Center Lincoln, Nebraska 68583-0853		10. Project/Task/Work Unit No.	
		11. Contract © or Grant (G) No. TPF-5(193) Supplement #18	
12. Sponsoring Organization Name and Address Midwest States Regional Pooled Fund Program Nebraska Department of Roads 1500 Nebraska Highway 2 Lincoln, Nebraska 68502		13. Type of Report and Period Covered Final Report: 2009-2010	
		14. Sponsoring Agency Code RPF-10-POLE	
15. Supplementary Notes Prepared in cooperation with U.S. Department of Transportation, Federal Highway Administration.			
16. Abstract (Limit: 200 words) Existing breakaway couplings have several disadvantages, including proprietary in nature, prohibitively expensive, inconsistent energy absorption due to temperature effects, and variable fatigue strength due to corrosion. Thus, the Illinois Department of Transportation (ILDOT) developed a free-cutting, brass breakaway coupling for use on luminaire or support poles. The free-cutting, brass breakaway couplings in combination with luminaire poles were evaluated according to the Test Level-3 (TL-3) safety performance criteria found in NCHRP Report No. 350. A total of 7 tests were conducted at the Valmont/UNL-MwRSF pendulum testing facility in compliance with the impact criteria corresponding to test designation no. 3-60. The results of these tests were then used to predict the high-speed test results, test designation no. 3-61, using the FHWA-approved extrapolation equation. Luminaire poles used were selected to provide one of two worst-case impact scenarios: (1) a tall massive pole that requires the most energy to rotate the pole, or (2) the lightest and weakest pole that may bend, fracture, or crush before the couplings break away. Successful tests of these two scenarios then provided a range of pole sizes that could be used in combination with the brass couplings. Upon completion of the physical testing and extrapolation analysis, aluminum luminaire poles with nominal heights between 30 ft (9.1 m) and 55 ft (16.8 m) and weights less than 755 lb (343 kg) were found to satisfy the TL-3 safety performance criteria when evaluated with the brass couplings. However, the selected and tested heavy steel poles failed to satisfy the change in velocity limit for the high-speed test. Therefore, an analytical analysis was conducted to identify the largest steel poles that are compatible with the brass couplings.			
17. Document Analysis/Descriptors Highway Safety, Pendulum Test, Roadside Appurtenances, Compliance Test, NCHRP Report No. 350, Breakaway Brass Couplings, Non-Proprietary Couplings, Breakaway Pole		18. Availability Statement No restrictions. Document available from: National Technical Information Services, Springfield, Virginia 22161	
19. Security Class (this report) Unclassified	20. Security Class (this page) Unclassified	21. No. of Pages 246	22. Price

DISCLAIMER STATEMENT

This report was completed with funding from the Federal Highway Administration, U.S. Department of Transportation. The contents of this report reflect the views and opinions of the authors who are responsible for the facts and the accuracy of the data presented herein. The contents do not necessarily reflect the official views or policies of the state highway departments participating in the Midwest States Regional Pooled Fund Program nor the Federal Highway Administration, U.S. Department of Transportation. This report does not constitute a standard, specification, regulation, product endorsement, or an endorsement of manufacturers.

UNCERTAINTY OF MEASUREMENT STATEMENT

The Midwest Roadside Safety Facility (MwRSF) has determined the uncertainty of measurements for several parameters involved in standard full-scale crash testing and non-standard testing of roadside safety features. Information regarding the uncertainty of measurements for critical parameters is available upon request by the sponsor and the Federal Highway Administration.

The Independent Approving Authority (IAA) for the data contained herein was Mrs. Karla Lechtenberg, Research Associate Engineer.

ACKNOWLEDGEMENTS

The authors wish to acknowledge several sources that made a contribution to this project: (1) the Midwest States Regional Pooled Fund Program funded by the Illinois Department of Transportation, Iowa Department of Transportation, Kansas Department of Transportation, Minnesota Department of Transportation, Missouri Department of Transportation, Nebraska Department of Roads, Ohio Department of Transportation, South Dakota Department of Transportation, Wisconsin Department of Transportation, and Wyoming Department of Transportation for sponsoring this project; and (2) Valmont Industries, Inc. for assisting MwRSF personnel with the pendulum testing program.

Acknowledgement is also given to the following individuals who made a contribution to the completion of this research project.

Midwest Roadside Safety Facility

J.C. Holloway, M.S.C.E., E.I.T., Test Site Manager
R.W. Bielenberg, M.S.M.E., E.I.T., Research Associate Engineer
C.L. Meyer, B.S.M.E., E.I.T., Research Associate Engineer
A.T. Russell, B.S.B.A., Shop Manager
K.L. Krenk, B.S.M.A, Maintenance Mechanic
Undergraduate and Graduate Research Assistants

Illinois Department of Transportation

David Piper, P.E., Highway Policy Engineer
Chris Hahin, P.E., Bridge Investigations Engineer
Mark Seppelt, P.E., Electrical Unit Chief

Iowa Department of Transportation

David Little, P.E., Assistant District Engineer
Deanna Maifield, P.E., Methods Engineer
Chris Poole, P.E., Litigation/Roadside Safety Engineer

Kansas Department of Transportation

Ron Seitz, P.E., Bureau Chief
Rod Lacy, P.E., Metro Engineer
Scott King, P.E., Road Design Leader

Minnesota Department of Transportation

Michael Elle, P.E., Design Standard Engineer

Missouri Department of Transportation

Joseph G. Jones, P.E., Engineering Policy Administrator

Nebraska Department of Roads

Amy Starr, P.E., Research Engineer
Phil TenHulzen, P.E., Design Standards Engineer
Jodi Gibson, Research Coordinator

Ohio Department of Transportation

Dean Focke, P.E., Road Safety Engineer (Retired)
Michael Blin, P.E., Standards and Geometrics Engineer

South Dakota Department of Transportation

David Huft, Research Engineer
Bernie Clocksin, Lead Project Engineer

Wisconsin Department of Transportation

John Bridwell, P.E., Standards Development Engineer
Eric Emerson, P.E., Standards Development Engineer
Jerry Zogg, P.E., Chief Roadway Standards Engineer

Wyoming Department of Transportation

William Wilson, P.E., Architecture and Highway Standards Engineer

Federal Highway Administration

John Perry, P.E., Nebraska Division Office
Danny Briggs, Nebraska Division Office

TABLE OF CONTENTS

TECHNICAL REPORT DOCUMENTATION PAGE	i
DISCLAIMER STATEMENT	ii
UNCERTAINTY OF MEASUREMENT STATEMENT	ii
ACKNOWLEDGEMENTS	iii
TABLE OF CONTENTS.....	v
LIST OF FIGURES	viii
LIST OF TABLES	xii
1 INTRODUCTION	1
1.1 Problem Statement.....	1
1.2 Research Objective	2
1.3 Scope.....	2
2 CRUSHABLE NOSE PENDULUM DETAILS	3
2.1 Pendulum System Details	3
2.1.1 Support Structure	3
2.1.2 Pendulum Assembly	3
2.1.3 Crushable Nose	4
2.2 Pendulum Weight.....	5
3 TEST REQUIREMENTS AND EVALUATION CRITERIA	19
3.1 Test Requirements	19
3.2 Evaluation Criteria	20
4 TEST CONDITIONS.....	23
4.1 Testing Facility	23
4.2 Data Acquisition Systems	23
4.2.1 Accelerometers	23
4.3 Photography Cameras	24
4.4 Speed Trap, Wooden Dowels	27
5 TEST INSTALLATION DETAILS – ROUND 1	28
5.1 Luminaire.....	28
5.1.1 Heavy Steel Luminaire Pole, Test No. BBC-1	28
5.1.2 Light Aluminum Luminaire Pole, Test No. BBC-2.....	29
5.2 Breakaway Brass Couplings, Test Nos. BBC-1 and BBC-2	29
5.3 Simulated Rigid Foundation	30
6 PENDULUM TEST NO. BBC-1.....	42
6.1 Test No. BBC-1	42

- 6.2 Weather Conditions 42
- 6.3 Test Description 42
- 6.4 System Damage 43
- 6.5 Occupant Risk 44
- 6.6 Discussion 44

- 7 PENDULUM TEST NO. BBC-2 51
 - 7.1 Test No. BBC-2 51
 - 7.2 Weather Conditions 51
 - 7.3 Test Description 51
 - 7.4 System Damage 53
 - 7.5 Occupant Risk 53
 - 7.6 Discussion 54

- 8 SUMMARY OF ROUND 1 TESTING 60

- 9 TEST INSTALLATION DETAILS – ROUND 2 63
 - 9.1 Breakaway Brass Couplings (Version 2), Test Nos. BBC-3 and BBC-5 63
 - 9.2 TRANSP Industries, Inc. Breakaway Coupling, Test No. BBC-4 64
 - 9.3 Luminaire Poles 64

- 10 PENDULUM TEST NO. BBC-3 71
 - 10.1 Test No. BBC-3 71
 - 10.2 Weather Conditions 71
 - 10.3 Test Description 71
 - 10.4 System Damage 72
 - 10.5 Occupant Risk 73
 - 10.6 Discussion 73

- 11 PENDULUM TEST NO. BBC-4 80
 - 11.1 Test No. BBC-4 80
 - 11.2 Weather Conditions 80
 - 11.3 Test Description 80
 - 11.4 System Damage 81
 - 11.5 Occupant Risk 82
 - 11.6 Discussion 82

- 12 PENDULUM TEST NO. BBC-5 89
 - 12.1 Test No. BBC-5 89
 - 12.2 Weather Conditions 89
 - 12.3 Test Description 89
 - 12.4 System Damage 90
 - 12.5 Occupant Risk 90
 - 12.6 Discussion 91

- 13 SUMMARY OF ROUND 2 TESTING 97

- 14 TEST INSTALLATION DETAILS – ROUND 3 101

14.1 Breakaway Brass Couplings (Version 3), Test Nos. BBC-6 and BBC-7	101
14.2 Luminaire Poles	101
14.2.1 Steel Luminaire Pole, Test No. BBC-6.....	102
14.2.2 Aluminum Luminaire Pole, Test No. BBC-7	102
15 PENDULUM TEST NO. BBC-6.....	111
15.1 Test No. BBC-6	111
15.2 Weather Conditions	111
15.3 Test Description.....	111
15.4 System Damage	112
15.5 Occupant Risk.....	113
15.6 Discussion.....	113
16 PENDULUM TEST NO. BBC-7.....	120
16.1 Test No. BBC-7	120
16.2 Weather Conditions	120
16.3 Test Description.....	120
16.4 System Damage	121
16.5 Occupant Risk.....	122
16.6 Discussion.....	123
17 ROUND 3 TESTING SUMMARY	130
18 ANALYTICAL EXTRAPOLATION OF HIGH-SPEED TEST RESULTS.....	133
19 STEEL LUMINAIRE POLE ANALYSIS	137
19.1 Analysis Methodology and Procedure.....	137
19.2 Results.....	139
20 SUMMARY, CONCLUSIONS AND RECOMMENDATIONS.....	141
21 REFERENCES	147
22 APPENDICES	148
Appendix A. Material Specifications.....	149
Appendix B. Accelerometer Data Plots, Test No. BBC-1	176
Appendix C. Accelerometer Data Plots, Test No. BBC-2	186
Appendix D. Accelerometer Data Plots, Test No. BBC-3	196
Appendix E. Accelerometer Data Plots, Test No. BBC-4	206
Appendix F. Accelerometer Data Plots, Test No. BBC-5.....	216
Appendix G. Accelerometer Data Plots, Test No. BBC-6.....	226
Appendix H. Accelerometer Data Plots, Test No. BBC-7.....	236

LIST OF FIGURES

Figure 1. Pendulum Support Structure Details	6
Figure 2. Pendulum and Crushable Nose Assembly.....	7
Figure 3. Pendulum Details.....	8
Figure 4. Pendulum Details.....	9
Figure 5. Crushable Nose Assembly.....	10
Figure 6. Crushable Nose Details	11
Figure 7. Crushable Nose Details	12
Figure 8. Crushable Nose, Aluminum Honeycomb Details	13
Figure 9. Crushable Nose, Aluminum Honeycomb Details	14
Figure 10. Crushable Nose, Fiberglass Spacer Details	15
Figure 11. Crushable-Nose Pendulum Facility.....	16
Figure 12. Wooden Dowel Setup.....	27
Figure 13. Steel Pole Details, Test Nos. BBC-1, BBC-3, and BBC-4.....	31
Figure 14. Steel Pole Base Details, Test Nos. BBC-1, BBC-3, and BBC-4.....	32
Figure 15. Steel Truss Arm Details, Test Nos. BBC-1, BBC-3, and BBC-4	33
Figure 16. Aluminum Pole Details, Test Nos. BBC-2 and BBC-5.....	34
Figure 17. Aluminum Luminaire Arm Details, Test Nos. BBC-2 and BBC-5.....	35
Figure 18. Breakaway Brass Coupling (Version 1) Details, Test Nos. BBC-1 and BBC-2.....	36
Figure 19. Brass Couplings (Version 1), Test Nos, BBC-1 and BBC-2.....	37
Figure 20. Nylon Inserts for Brass Couplings, Test No. BBC-1	37
Figure 21. Simulated Rigid Foundation Details	38
Figure 22. Support Beam and Adapter Plate Details	39
Figure 23. Assembled Test Installation, Test No. BBC-1	40
Figure 24. Assembled Test Installation, Test No. BBC-2	41
Figure 25. Summary of Test Results and Sequential Photographs, Test No. BBC-1	46
Figure 26. Additional Sequential Photographs, Test No. BBC-1	47
Figure 27. Additional Sequential Photographs, Test No. BBC-1	48
Figure 28. System Damage, Test No. BBC-1	49
Figure 29. System Damage, Test No. BBC-1	50
Figure 30. Summary of Test Results and Sequential Photographs, Test No. BBC-2.....	55
Figure 31. Additional Sequential Photographs, Test No. BBC-2	56
Figure 32. Additional Sequential Photographs, Test No. BBC-2.....	57
Figure 33. System Damage, Test No. BBC-2.....	58
Figure 34. System Damage, Test No. BBC-2.....	59
Figure 35. Brass Coupling (Version 2) Detail, Test Nos. BBC-3 and BBC-5	66
Figure 36. 1-in. (25-mm) Diameter, TRANSPO Pole-Safe Breakaway Coupling Details, Test No. BBC-4	67
Figure 37. Assembled Test Installation, Test No. BBC-3	68
Figure 38. Assembled Test Installation, Test No. BBC-4	69
Figure 39. Assembled Test Installation, Test No. BBC-5	70
Figure 40. Summary of Test Results and Sequential Photographs, Test No. BBC-3.....	75
Figure 41. Additional Sequential Photographs, Test No. BBC-3	76
Figure 42. Additional Sequential Photographs, Test No. BBC-3	77
Figure 43. System Damage, Test No. BBC-3.....	78
Figure 44. System Damage, Test No. BBC-3.....	79

Figure 45. Summary of Test Results and Sequential Photographs, Test No. BBC-4.....	84
Figure 46. Additional Sequential Photographs, Test No. BBC-4.....	85
Figure 47. Additional Sequential Photographs, Test No. BBC-4.....	86
Figure 48. System Damage, Test No. BBC-4.....	87
Figure 49. System Damage, Test No. BBC-4.....	88
Figure 50. Summary of Test Results and Sequential Photographs, Test No. BBC-5.....	93
Figure 51. Additional Sequential Photographs, Test No. BBC-5.....	94
Figure 52. Additional Sequential Photographs, Test No. BBC-5.....	95
Figure 53. System Damage, Test No. BBC-5.....	96
Figure 54. Version 3 Brass Coupling Details, Test Nos. BBC-6 and BBC-7	104
Figure 55. Version 3 Brass Couplings, Test Nos. BBC-6 and BBC-7	105
Figure 56. Steel Luminaire Pole, Test No. BBC-6	106
Figure 57. Aluminum Luminaire Pole Details, Test No. BBC-7.....	107
Figure 58. Aluminum Luminaire Arm Details, Test No. BBC-7	108
Figure 59. Assembled Test Installation, Test No. BBC-6	109
Figure 60. Assembled Test Installation, Test No. BBC-7	110
Figure 61. Summary of Test Results and Sequential Photographs, Test No. BBC-6.....	115
Figure 62. Additional Sequential Photographs, Test No. BBC-6.....	116
Figure 63. Additional Sequential Photographs, Test No. BBC-6.....	117
Figure 64. System Damage, Test No. BBC-6.....	118
Figure 65. System Damage, Test No. BBC-6.....	119
Figure 66. Summary of Test Results and Sequential Photographs, Test No. BBC-7.....	124
Figure 67. Additional Sequential Photographs, Test No. BBC-7.....	125
Figure 68. Additional Sequential Photographs, Test No. BBC-7.....	126
Figure 69. System Damage, Test No. BBC-7.....	127
Figure 70. System Damage, Test No. BBC-7.....	128
Figure 71. System Damage, Test No. BBC-7.....	129
Figure A-1. Aluminum Honeycomb Element No. 1 Material Certification.....	150
Figure A-2. Aluminum Honeycomb Element No. 2 Material Certification.....	151
Figure A-3. Aluminum Honeycomb Element No. 3 Material Certification.....	152
Figure A-4. Aluminum Honeycomb Element Nos. 4 through 6 Material Certification.....	153
Figure A-5. Aluminum Honeycomb Element Nos. 7 through 9 Material Certification.....	154
Figure A-6. Aluminum Honeycomb Element No. 10 Material Certification.....	155
Figure A-7. Brass Coupling Material Certification, Test Nos. BBC-1 and BBC-2.....	156
Figure A-8. Brass Material Certification, Test Nos. BBC-3 and BBC-5 Through BBC- 7	157
Figure A-9. Threaded Rod For Brass Couplings Material Certification	158
Figure A-10. Steel Pole Material Certification, Test Nos. BBC-1, BBC-3, and BBC-4.....	159
Figure A-11. Steel Arms Material Certification, Test Nos. BBC-1, BBC-3, and BBC-4	160
Figure A-12. Steel Arm Simplex Material Certification, Test Nos. BBC-1, BBC-3, and BBC-4	161
Figure A-13. Steel Base Plate Material Certification, Test Nos. BBC-1, BBC-3, and BBC-4 ..	162
Figure A-14. Steel Pole Simplex Material Certification, Test Nos. BBC-1, BBC-3, and BBC-4	163
Figure A-15. Aluminum Pole Material Certification, Test Nos. BBC-2 and BBC-5.....	164
Figure A-16. Steel Luminaire Material Certification, Test No. BBC-6	165
Figure A-17. Steel Pole Material Certification, Test No. BBC-6.....	166
Figure A-18. Steel Pole Material Certification, Test No. BBC-6.....	167

Figure A-19. Steel Arms Material Certification, Test No. BBC-6	168
Figure A-20. Steel Arm Material Certification, Test No. BBC-6.....	169
Figure A-21. Steel Pole Simplex Material Certification, Test No. BBC-6.....	170
Figure A-22. Steel Arm Simplex Material Certification, Test No. BBC-6	171
Figure A-23. Steel Base Plate Material Certification, Test No. BBC-6	172
Figure A-24. Aluminum Pole Material Certification, Test No. BBC-7.....	173
Figure A-25. Aluminum Pole Material Certification, Test No. BBC-7.....	174
Figure A-26. Aluminum Arms Material Certification, Test No. BBC-7.....	175
Figure B-1. Longitudinal Deceleration (DTS-BR39H), Test No. BBC-1	177
Figure B-2. Longitudinal Change in Velocity (DTS-BR39H), Test No. BBC-1	178
Figure B-3. Longitudinal Change in Displacement (DTS-BR39H), Test No. BBC-1	179
Figure B-4. Longitudinal Deceleration (DTS-CM54H), Test No. BBC-1	180
Figure B-5. Longitudinal Change in Velocity (DTS-CM54H), Test No. BBC-1.....	181
Figure B-6. Longitudinal Change in Displacement (DTS-CM54H), Test No. BBC-1	182
Figure B-7. Longitudinal Deceleration (EDR-3), Test No. BBC-1	183
Figure B-8. Longitudinal Change in Velocity (EDR-3), Test No. BBC-1	184
Figure B-9. Longitudinal Change in Displacement (EDR-3), Test No. BBC-1	185
Figure C-1. Longitudinal Deceleration (DTS-BR39H), Test No. BBC-2	187
Figure C-2. Longitudinal Change in Velocity (DTS-BR39H), Test No. BBC-2	188
Figure C-3. Longitudinal Change in Displacement (DTS-BR39H), Test No. BBC-2	189
Figure C-4. Longitudinal Deceleration (DTS-CM54H), Test No. BBC-2	190
Figure C-5. Longitudinal Change in Velocity (DTS-CM54H), Test No. BBC-2.....	191
Figure C-6. Longitudinal Change in Displacement (DTS-CM54H), Test No. BBC-2	192
Figure C-7. Longitudinal Deceleration (EDR-3), Test No. BBC-2.....	193
Figure C-8. Longitudinal Change in Velocity (EDR-3), Test No. BBC-2	194
Figure C-9. Longitudinal Change in Displacement (EDR-3), Test No. BBC-2.....	195
Figure D-1. Longitudinal Deceleration (DTS-BF57H), Test No. BBC-3	197
Figure D-2. Longitudinal Change in Velocity (DTS-BF57H), Test No. BBC-3.....	198
Figure D-3. Longitudinal Change in Displacement (DTS-BF57H), Test No. BBC-3	199
Figure D-4. Longitudinal Deceleration (DTS-CM54H), Test No. BBC-3	200
Figure D-5. Longitudinal Change in Velocity (DTS-CM54H), Test No. BBC-3	201
Figure D-6. Longitudinal Change in Displacement (DTS-CM54H), Test No. BBC-3	202
Figure D-7. Longitudinal Deceleration (EDR-3), Test No. BBC-3.....	203
Figure D-8. Longitudinal Change in Velocity (EDR-3), Test No. BBC-3	204
Figure D-9. Longitudinal Change in Displacement (EDR-3), Test No. BBC-3.....	205
Figure E-1. Longitudinal Deceleration (DTS-BF57H), Test No. BBC-4.....	207
Figure E-2. Longitudinal Change in Velocity (DTS-BF57H), Test No. BBC-4	208
Figure E-3. Longitudinal Change in Displacement (DTS-BF57H), Test No. BBC-4.....	209
Figure E-4. Longitudinal Deceleration (DTS-CM54H), Test No. BBC-4	210
Figure E-5. Longitudinal Change in Velocity (DTS-CM54H), Test No. BBC-4.....	211
Figure E-6. Longitudinal Change in Displacement (DTS-CM54H), Test No. BBC-4.....	212
Figure E-7. Longitudinal Deceleration (EDR-3), Test No. BBC-4	213
Figure E-8. Longitudinal Change in Velocity (EDR-3), Test No. BBC-4	214
Figure E-9. Longitudinal Change in Displacement (EDR-3), Test No. BBC-4	215
Figure F-1. Longitudinal Deceleration (DTS-BF57H), Test No. BBC-5.....	217
Figure F-2. Longitudinal Change in Velocity (DTS-BF57H), Test No. BBC-5	218
Figure F-3. Longitudinal Change in Displacement (DTS-BF57H), Test No. BBC-5	219

Figure F-4. Longitudinal Deceleration (DTS-CM54H), Test No. BBC-5.....	220
Figure F-5. Longitudinal Change in Velocity (DTS-CM54H), Test No. BBC-5.....	221
Figure F-6. Longitudinal Change in Displacement (DTS-CM54H), Test No. BBC-5.....	222
Figure F-7. Longitudinal Deceleration (EDR-3), Test No. BBC-5.....	223
Figure F-8. Longitudinal Change in Velocity (EDR-3), Test No. BBC-5.....	224
Figure F-9. Longitudinal Change in Displacement (EDR-3), Test No. BBC-5.....	225
Figure G-1. Longitudinal Deceleration (DTS-BF57H), Test No. BBC-6.....	227
Figure G-2. Longitudinal Change in Velocity (DTS-BF57H), Test No. BBC-6.....	228
Figure G-3. Longitudinal Change in Displacement (DTS-BF57H), Test No. BBC-6.....	229
Figure G-4. Longitudinal Deceleration (DTS-CM54H), Test No. BBC-6.....	230
Figure G-5. Longitudinal Change in Velocity (DTS-CM54H), Test No. BBC-6.....	231
Figure G-6. Longitudinal Change in Displacement (DTS-CM54H), Test No. BBC-6.....	232
Figure G-7. Longitudinal Deceleration (EDR-3), Test No. BBC-6.....	233
Figure G-8. Longitudinal Change in Velocity (EDR-3), Test No. BBC-6.....	234
Figure H-1. Longitudinal Deceleration (DTS-BF57H), Test No. BBC-7.....	237
Figure H-2. Longitudinal Change in Velocity (DTS-BF57H), Test No. BBC-7.....	238
Figure H-3. Longitudinal Change in Displacement (DTS-BF57H), Test No. BBC-7.....	239
Figure H-4. Longitudinal Deceleration (DTS-CM54H), Test No. BBC-7.....	240
Figure H-5. Longitudinal Change in Velocity (DTS-CM54H), Test No. BBC-7.....	241
Figure H-6. Longitudinal Change in Displacement (DTS-CM54H), Test No. BBC-7.....	242
Figure H-7. Longitudinal Deceleration (EDR-3), Test No. BBC-7.....	243
Figure H-8. Longitudinal Change in Velocity (EDR-3), Test No. BBC-7.....	244

LIST OF TABLES

Table 1. Aluminum Honeycomb Details	17
Table 2. Pendulum Assembly Weight by Round and Test	18
Table 3. NCHRP Report No. 350 TL-3 Crash Test Conditions	19
Table 4. Evaluation Criteria for Breakaway Support Structures	22
Table 5. Camera Data, Test Nos. BBC-1 and BBC-2.....	26
Table 6. Camera Data, Test Nos. BBC-3 through BBC-5	26
Table 7. Camera Data, Test Nos. BBC-6 and BBC-7.....	26
Table 8. Weather Conditions, Test No. BBC-1	42
Table 9. Sequential Description of Impact Events, Test No. BBC-1	43
Table 10. Occupant Risk Summary, Test No. BBC-1	44
Table 11. Weather Conditions, Test No. BBC-2	51
Table 12. Sequential Description of Impact Events, Test No. BBC-2	52
Table 13. Occupant Risk Summary, Test No. BBC-2	53
Table 14. Summary of Safety Performance Evaluation Results, Round 1 Testing Program	62
Table 15. Weather Conditions, Test No. BBC-3	71
Table 16. Sequential Description of Impact Events, Test No. BBC-3	72
Table 17. Occupant Risk Summary, Test No. BBC-3	73
Table 18. Weather Conditions, Test No. BBC-4	80
Table 19. Sequential Description of Impact Events, Test No. BBC-4	81
Table 20. Occupant Risk Summary, Test No. BBC-4	82
Table 21. Weather Conditions, Test No. BBC-5	89
Table 22. Sequential Description of Impact Events, Test No. BBC-5	90
Table 23. Occupant Risk Summary, Test No. BBC-5	91
Table 24. Summary of Safety Performance Evaluation Results, Round 2 Testing Program	100
Table 25. Weather Conditions, Test No. BBC-6	111
Table 26. Sequential Description of Impact Events, Test No. BBC-6	112
Table 27. Occupant Risk Summary, Test No. BBC-6	113
Table 28. Weather Conditions, Test No. BBC-7	120
Table 29. Sequential Description of Impact Events, Test No. BBC-7	121
Table 30. Occupant Risk Summary, Test No. BBC-7	122
Table 31. Summary of Safety Performance Evaluation Results, Round Three Tests	132
Table 32. Summary of High-Speed ΔV Results from Extrapolation Procedures	134
Table 33. Maximum Size of Steel Pole Results.....	140
Table 34. Applicable Luminaire Pole Systems for Use with the Brass Breakaway Couplings..	146

1 INTRODUCTION

1.1 Problem Statement

Breakaway couplings are commonly used to mitigate the severity of impacts between errant vehicles and luminaire or support poles placed at the edge of the roadway. However, existing breakaway couplings also have several disadvantages. All existing breakaway couplings are proprietary in nature and have some State Highway Agencies referring to them as prohibitively expensive. For example, the new breakaway coupling offered by Transpo Industries, Inc., which consists of a double hourglass-shaped coupling made from a brittle steel, costs between \$50 to \$75 per coupling. Because four couplings are often used per pole system, the cost for the set of couplings can range between \$200 and \$300, which may approach the installation cost for a typical light pole.

Moreover, existing steel couplings do not have consistent energy absorption as a function of temperature due to the effect of the steel's ductile-to-brittle transition temperature. The ductile-to-brittle transition temperature for common steel is approximately 40°F (4.4°C). Finally, many existing steel couplings are galvanized. Once the zinc has been depleted, the coupling will begin to corrode, which can potentially change the severity of the notch and alter its fatigue strength. Thus, there existed a need to develop a new breakaway coupling that reduced costs and eliminated the disadvantages of existing steel, breakaway couplings. Therefore, the Illinois Department of Transportation (ILDOT) developed a free-cutting, brass breakaway coupling for use on luminaire or support poles.

Modern safety performance standards for breakaway support structure systems are contained in two documents: (1) the National Cooperative Highway Research Program (NCHRP) Report No. 350, *Recommended Procedures for the Safety Performance Evaluation of Highway Features* [1] and (2) the American Association of State Highway and Transportation

Officials (AASHTO) *Standard Specifications for Structural Supports for Highway Signs, Luminaires, and Traffic Signals, Fifth Edition* [2]. These two documents detail a matrix that includes two full-scale tests with a small passenger vehicle. However, the Federal Highway Administration (FHWA) has approved the use of the Valmont-MwRSF/UNL crushable nose pendulum as a surrogate vehicle for analyzing breakaway devices [3]. Therefore, the Midwest States Pooled Fund Program desired to use the Valmont-MwRSF/UNL pendulum to evaluate the safety performance of the free-cutting, brass breakaway couplings.

1.2 Research Objective

The objective of this research study was to evaluate the safety performance of the brass breakaway couplings when utilized with steel and aluminum luminaire poles. The systems were tested with the Valmont-MwRSF/UNL pendulum and evaluated according to the Test Level 3 (TL-3) criteria established in NCHRP Report No. 350 as well as to the standards described in the *AASHTO Standard Specifications for Structural Supports for Highway Signs, Luminaires, and Traffic Signals, Fifth Edition*.

1.3 Scope

The first step in performing these tests was selecting luminaire poles which would represent the most critical configurations for small car impacts. Next, a series of low-speed, pendulum impact tests were conducted in accordance with NCHRP Report No. 350 test designation no. 3-60. The low-speed results were then used to estimate the results for the high-speed impact test, or test designation no. 3-61, using an analytical method recognized by FHWA [4-5]. This analytical method was further used to analyze the safety compliance of various luminaire pole configurations and sizes. Finally, recommendations were made regarding the use of the brass breakaway couplings.

2 CRUSHABLE NOSE PENDULUM DETAILS

2.1 Pendulum System Details

The Valmont-MwRSF/UNL pendulum that was utilized for this study consisted of three main components: (1) the support structure; (2) the pendulum; and (3) the crushable nose assembly. Each of these components is discussed briefly in the following sections. Detailed drawings and photographs of the pendulum system are shown in Figures 1 through 11.

2.1.1 Support Structure

The support structure consisted of two 60-ft (18.3-m) tall steel poles spaced 40 ft (12.2 m) apart laterally, as shown in Figure 1. The two support poles were connected at the top by a catwalk assembly and cross bracing. Four cables were attached to the support structure at a height of 42 ft – 11 in. (13.1 m) which supported the pendulum mass.

The rear lift structure was comprised of two additional steel poles. These poles had a height of 52 ft – 9 in. (16.1 m) and were spaced 6 ft (1.8 m) apart laterally. A winch was located at the base of these poles, and the winch cable extended up to a pulley attached to the top of the rear lift structure and continued to the back of the pendulum. This winch and pulley system was used to raise the pendulum mass to the desired elevation. The cable was released remotely to conduct the impact testing. Further details can be found in Reference 3.

2.1.2 Pendulum Assembly

The pendulum body consisted of a welded, steel plate box frame, as shown in Figures 2 through 4. Two longitudinal steel tubes were mounted through the box frame to act as guides for the crushable nose. A second set of four steel tubes were installed laterally through the pendulum box frame for installing through-bolts for use in attaching ballast plates to the pendulum body. The inside of the box frame was filled with concrete in order to strengthen the frame and add the necessary mass.

The pendulum body was supported by four ½-in. (13-mm) diameter, 6x25 XIP IWRC wire ropes. These wire ropes were attached to the support structure at a height of 42 ft – 11 in. (13.1 m) and adjusted to set the impact height of the pendulum at 17½ in. (445 mm) above the ground line. The wire ropes were configured to support the pendulum and keep the body level during the pendulum swing.

Note that the pendulum detailed in the drawings contained herein was not configured with a sweeper plate, as shown on other pendulums used at the Federal Outdoor Impact Laboratory (FOIL) and the Texas Transportation Institute (TTI) [6-8]. The purpose of the sweeper plate, as stated in previous reports, was to act as a sacrificial element that grossly replicated the undercarriage of an automobile. It was not believed that the sweeper plate was necessary for the testing detailed in this report. Thus, it was not utilized during the first two rounds of testing. However, the sweeper plate was added to the undercarriage of the pendulum prior to the third round of pendulum testing as it was deemed necessary for a different testing project.

2.1.3 Crushable Nose

The crushable nose was mounted on the front of the pendulum mass. It was based on the crushable nose developed and tested on the FOIL pendulum [6-7]. The aluminum nose tubes were attached to the aluminum impact head and slide into the guide tubes on the body of the pendulum. The crushable nose contained ten energy-absorbing aluminum honeycomb elements with various geometries and stiffness separated by a series of sliding, fiberglass plates. The aluminum honeycomb was pre-crushed in order to produce consistent force levels. Details of the crushable nose assembly and the aluminum honeycomb configuration are shown in Figures 5 through 10. Details for each of the ten aluminum honeycomb elements are shown in Table 1. The certificates of conformance for the aluminum honeycomb are shown in Appendix A.

2.2 Pendulum Weight

The Valmont-MwRSF/UNL crushable nose pendulum and all of its components were weighed and recorded prior to testing. The total weight of the pendulum for each test, including the crushable nose, aluminum honeycomb, and accelerometers, is shown in Table 2.

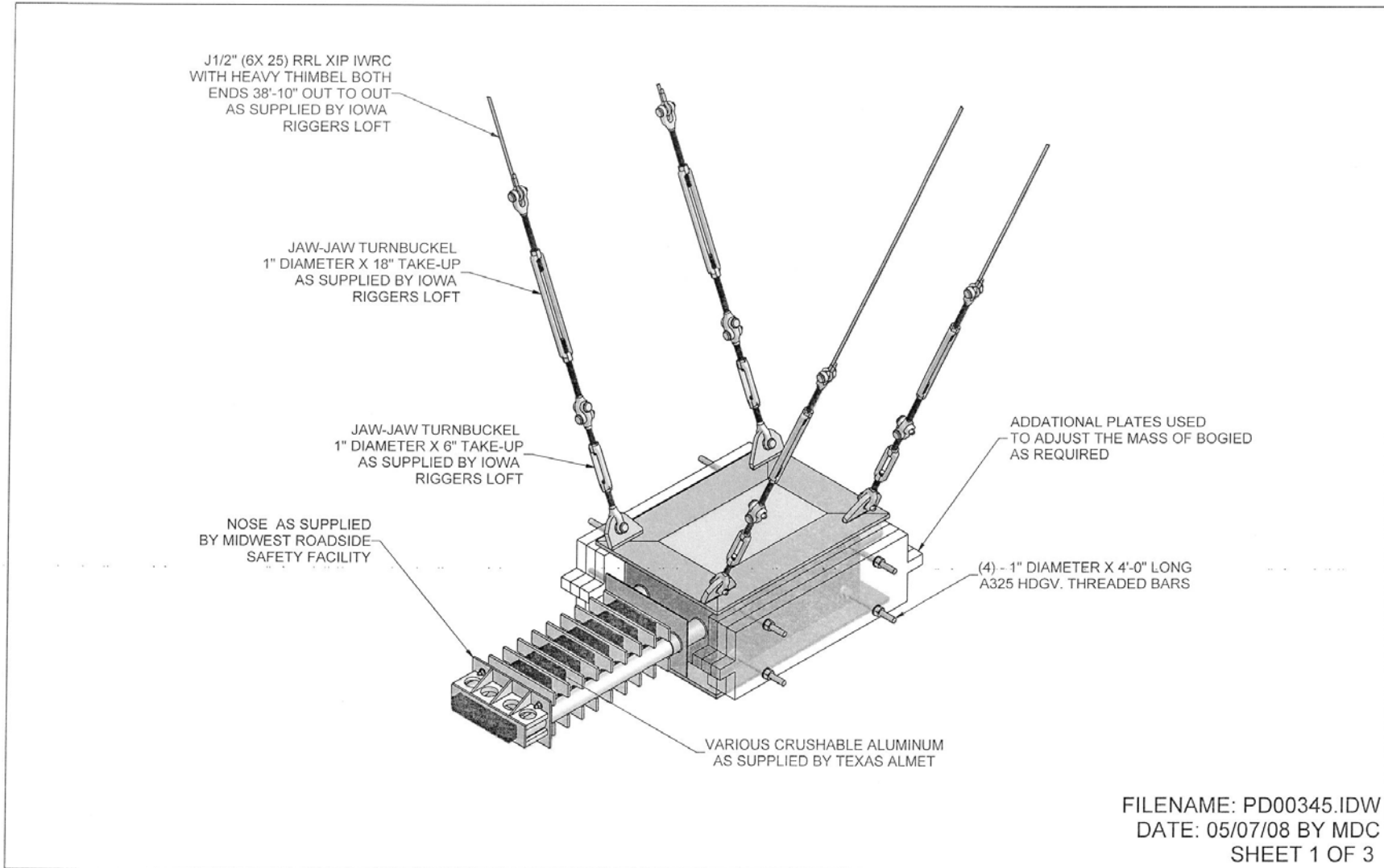

Figure 2. Pendulum and Crushable Nose Assembly

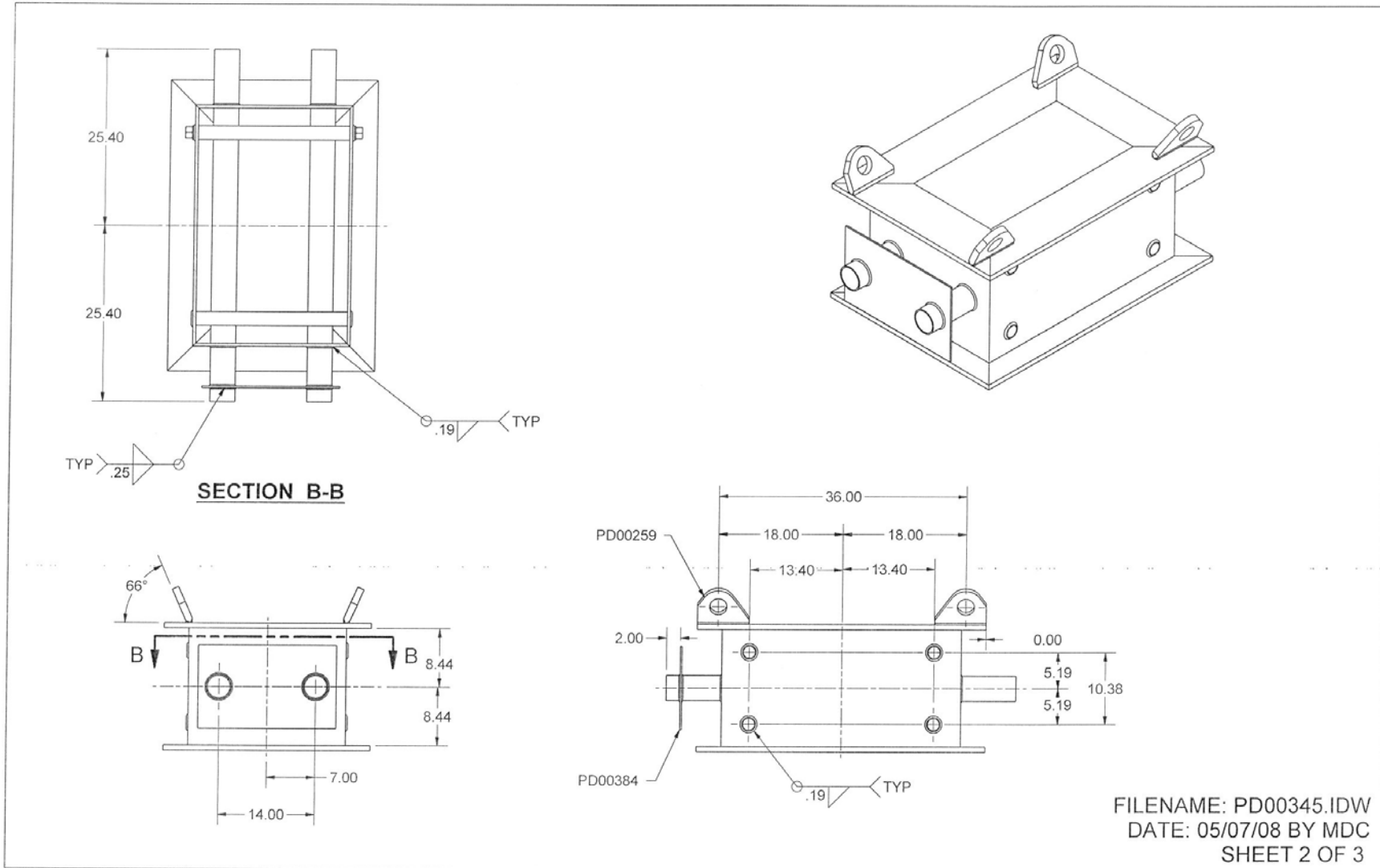
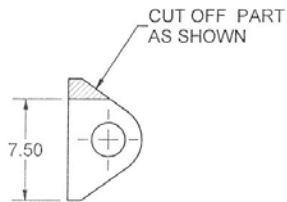
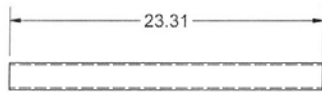
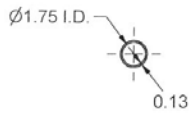
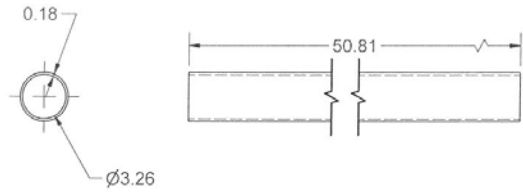
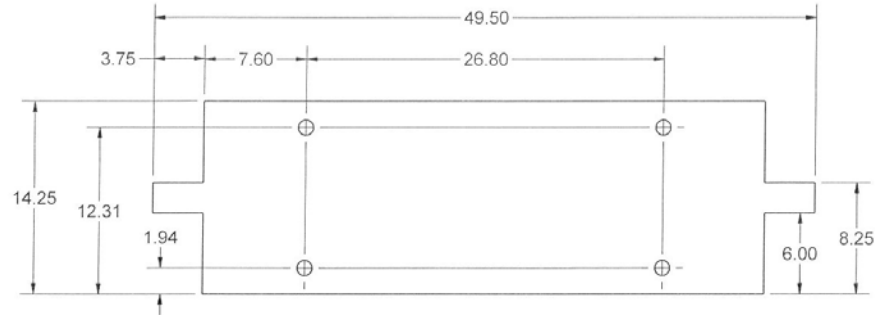

Figure 3. Pendulum Details



PD00259
 QUANTITY REQUIRED: 4



PD00387
 DESCRIPTION: PLATE 2.25 X 14.25 x 49.5
 MATERIAL: ANY
 WEIGHT: 389 lbs
 QUANTITY: 6

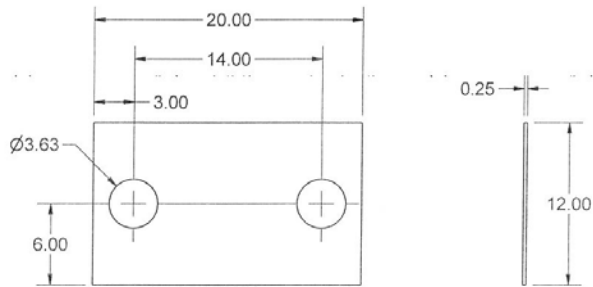

PD00384
 DESCRIPTION: PLATE
 MATERIAL: ANY
 QUANTITY: 1

FILENAME: PD00345.IDW
 DATE: 05/07/08 BY MDC
 SHEET 3 OF 3

Figure 4. Pendulum Details

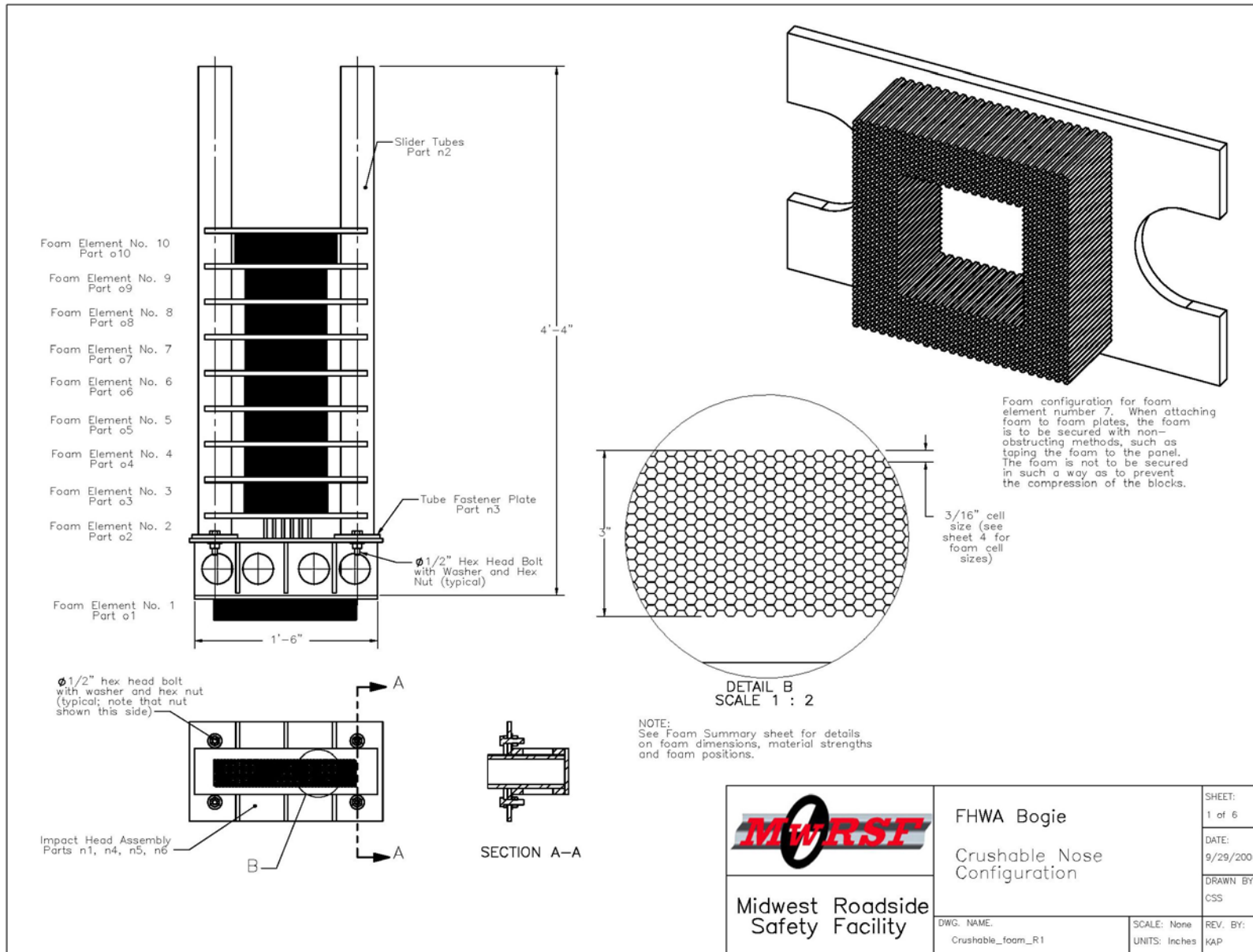

Figure 5. Crushable Nose Assembly

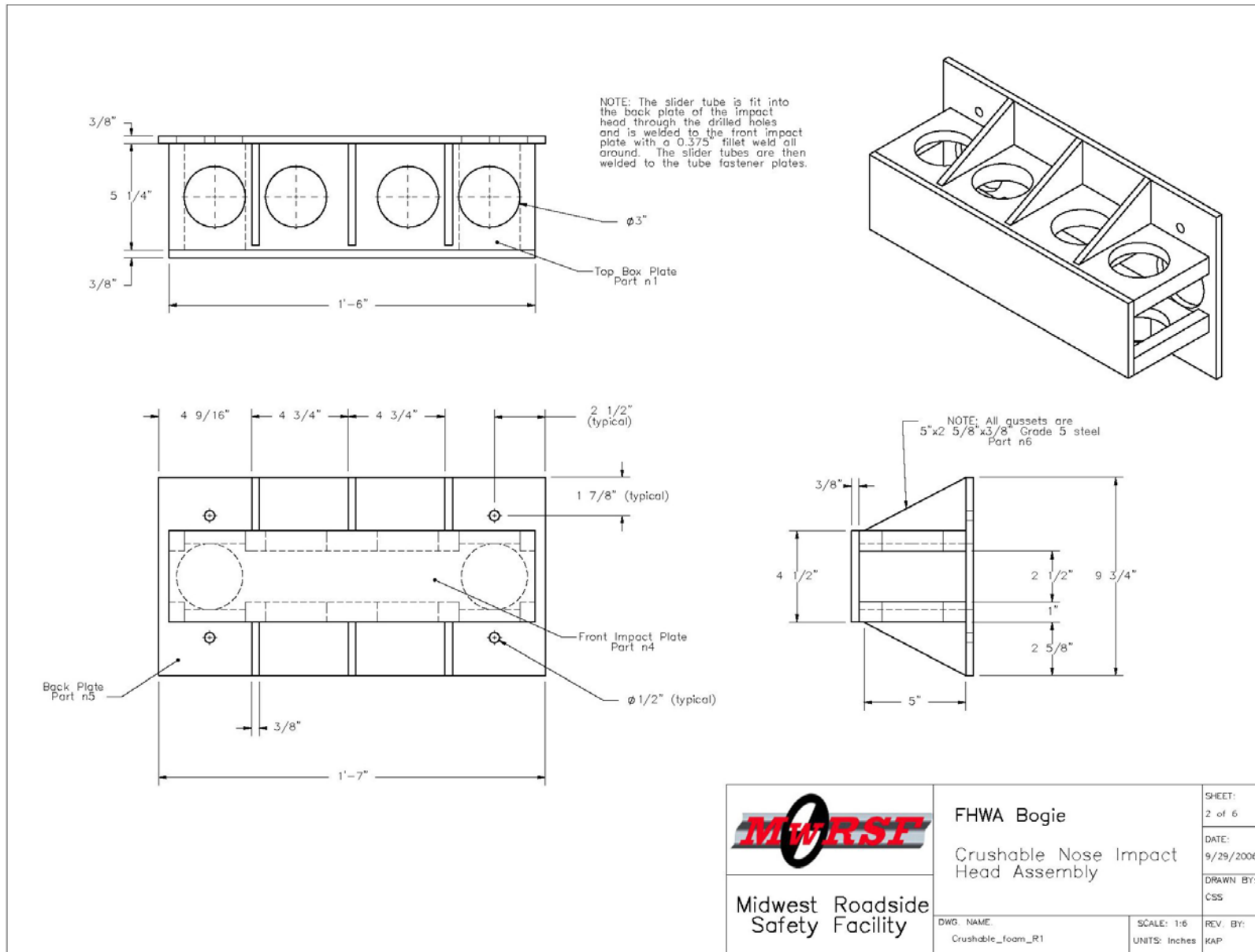



Figure 6. Crushable Nose Details

 Midwest Roadside Safety Facility	FHWA Bogie Crushable Nose Impact Head Assembly	SHEET: 2 of 6
	DWG. NAME: Crushable_foam_R1	SCALE: 1:6 UNITS: Inches

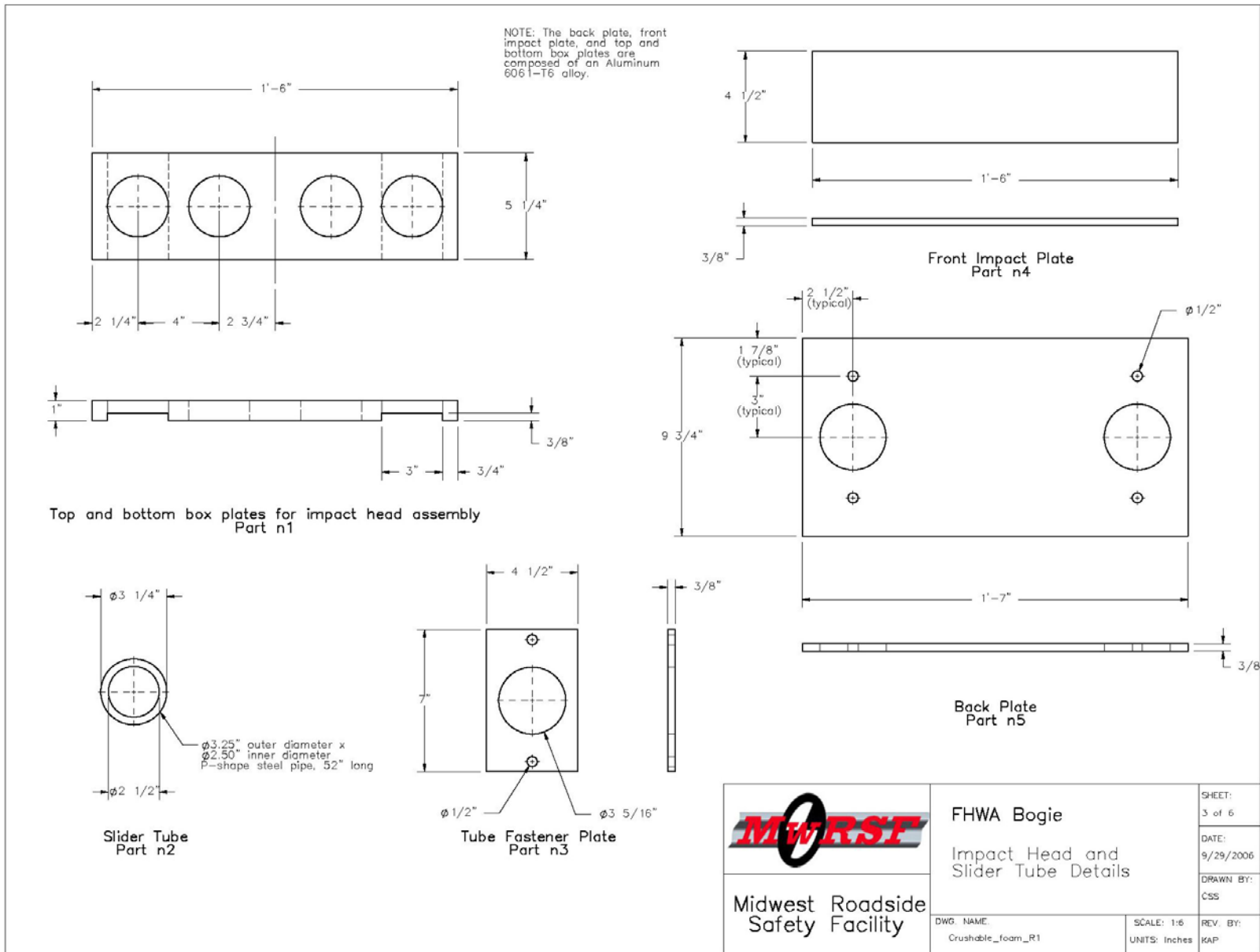

Figure 7. Crushable Nose Details

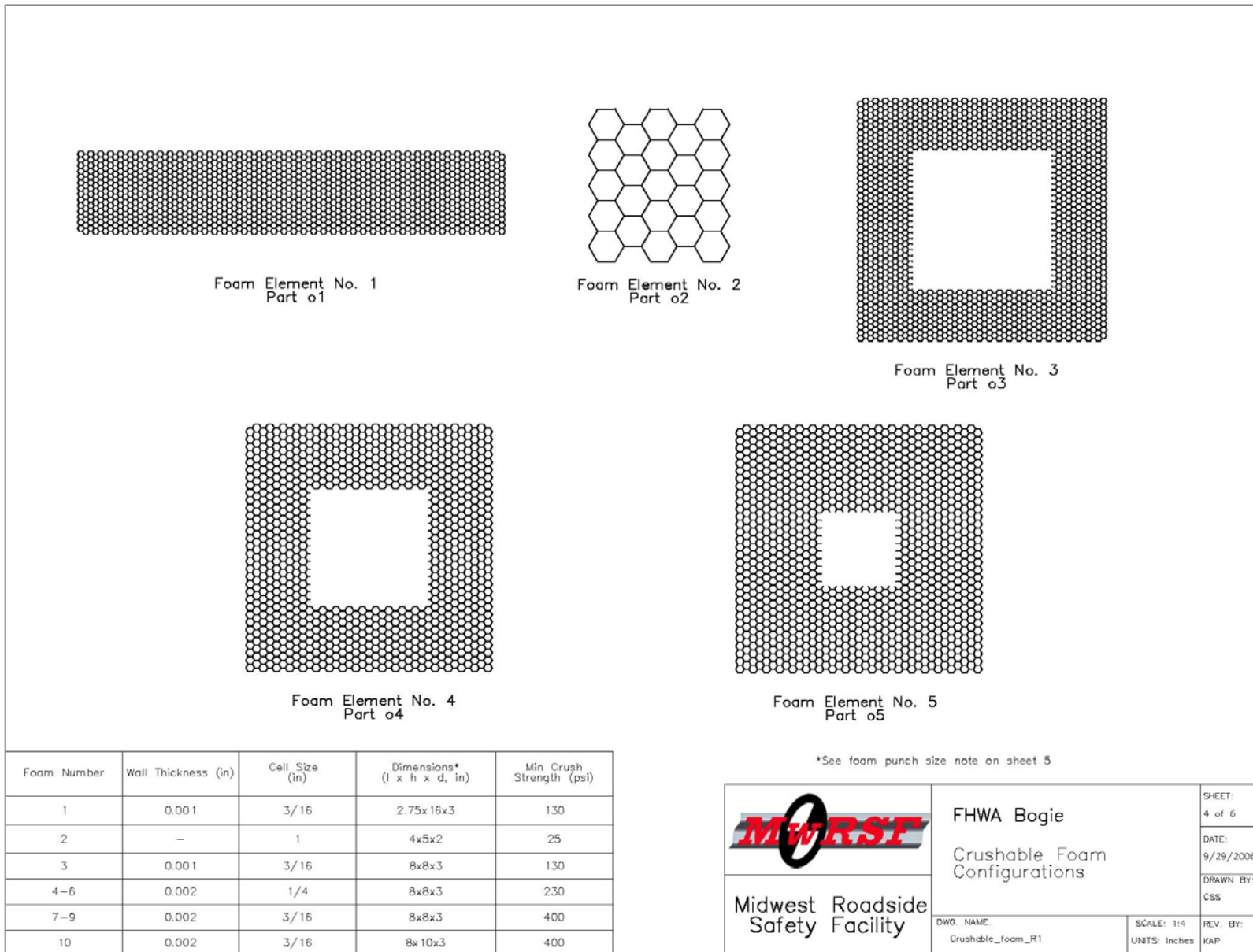

Figure 8. Crushable Nose, Aluminum Honeycomb Details

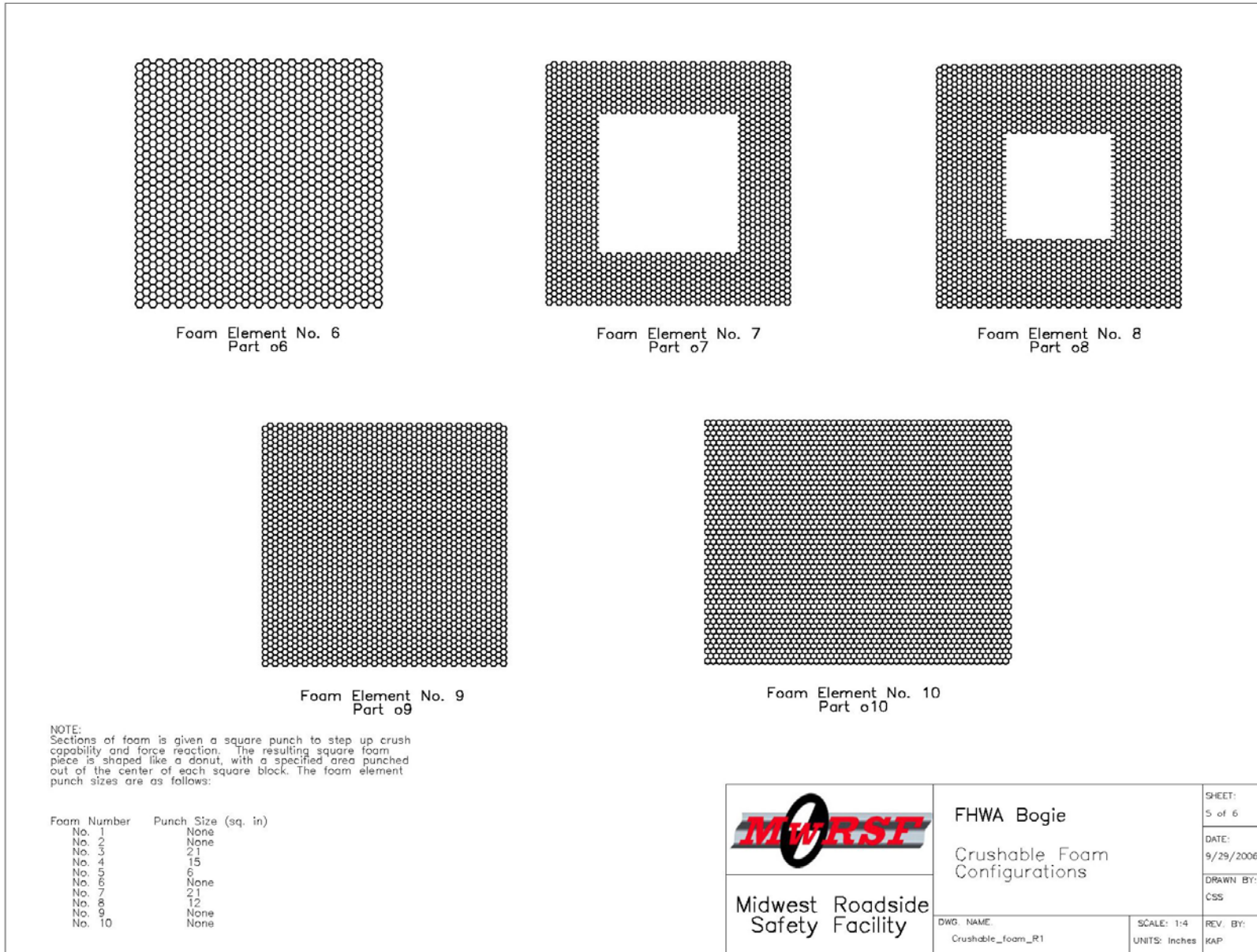

Figure 9. Crushable Nose, Aluminum Honeycomb Details

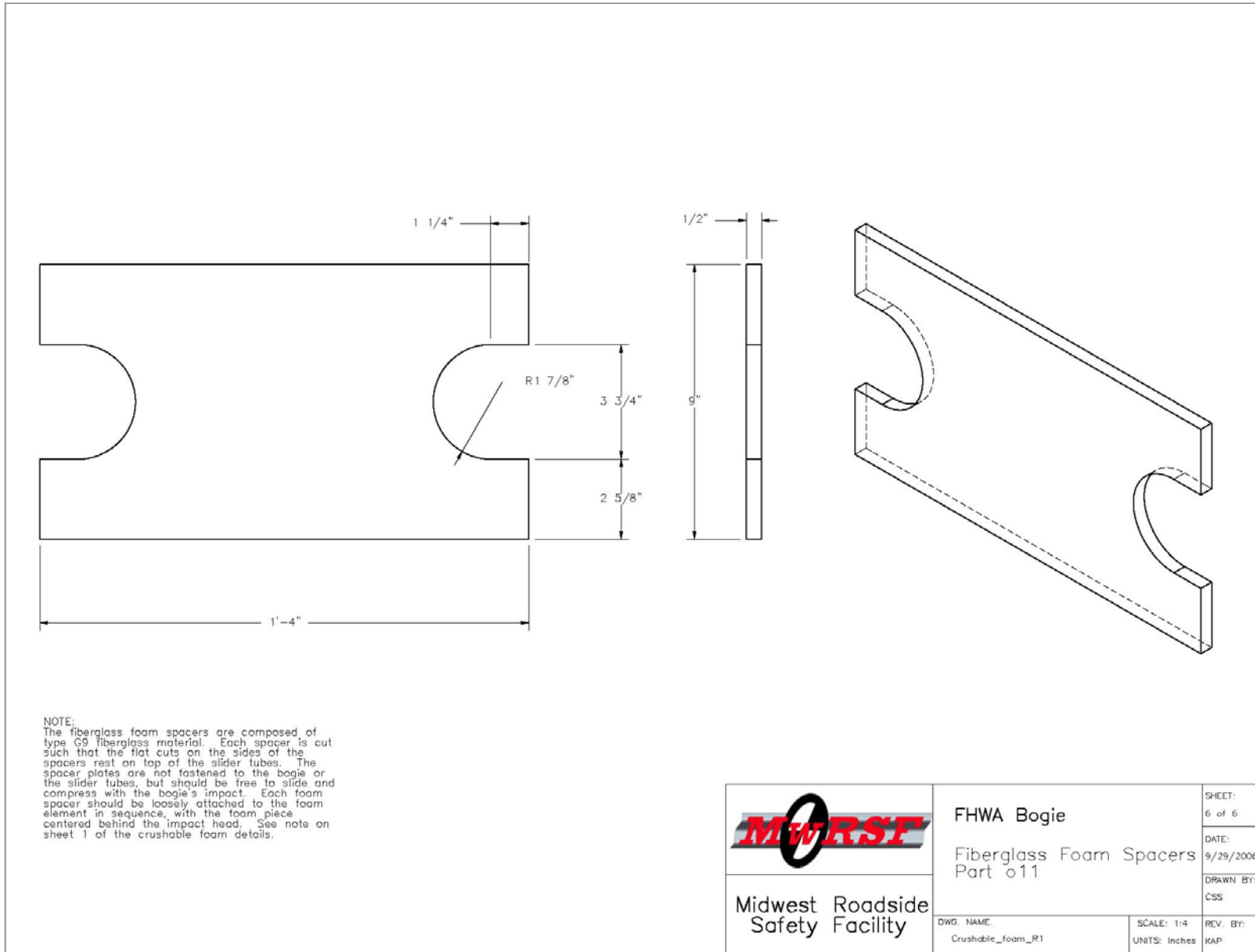

Figure 10. Crushable Nose, Fiberglass Spacer Details



Figure 11. Crushable-Nose Pendulum Facility

Table 1. Aluminum Honeycomb Details

Cartridge No.	Manufacturer (Part No.)	Density (pcf)	Original Dimensions (in.) (l x w x d)	Pre-Crush Depth (in.)	Crush Strength (psi)	Wall Thickness (in.)	Cell Size (in.)	Punch Size (in. ²)
1	Plascore (PAMG-XR1-3.1 3/16 .001N 5052)	3.1	2.75 x 16 x 3.25	3	130	0.001	0.1875	--
2	Plascore (PCGA-XR1-1.4 1/0 N 3003)	1.4	4 x 5 x 2	2	25	-	1.00	-
3	Plascore (PAMG-XR1-3.1 3/16 .001N 5052)	3.1	8 x 8 x 3.25	3	130	0.001	0.1875	21
4	Plascore (PAMG-XR1-4.3 1/4 .002N 5052)	4.3	8 x 8 x 3.25	3	230	0.002	0.25	15
5	Plascore (PAMG-XR1-4.3 1/4 .002N 5052)	4.3	8 x 8 x 3.25	3	230	0.002	0.25	6
6	Plascore (PAMG-XR1-4.3 1/4 .002N 5052)	4.3	8 x 8 x 3.25	3	230	0.002	0.25	-
7	Plascore (PAMG_XR1-5.7 3/16 .002N 5052)	5.7	8 x 8 x 3.25	3	400	0.002	0.1875	21
8	Plascore (PAMG_XR1-5.7 3/16 .002N 5052)	5.7	8 x 8 x 3.25	3	400	0.002	0.1875	12
9	Plascore (PAMG_XR1-5.7 3/16 .002N 5052)	5.7	8 x 8 x 3.25	3	400	0.002	0.1875	-
10	Plascore (PAMG_XR1-5.7 3/16 .002N 5052)	5.7	8 x 10 x 3.25	3	400	0.002	0.1875	-

Table 2. Pendulum Assembly Weight by Round and Test

ROUND NO.	TEST NO.	WEIGHT lb (kg)
1	BBC-1	1,878 (852)
	BBC-2	1,878 (852)
2	BBC-3	1,849 (839)
	BBC-4	1,849 (839)
	BBC-5	1,849 (839)
3	BBC-6	1,882 (854)
	BBC-7	1,882 (854)

3 TEST REQUIREMENTS AND EVALUATION CRITERIA

3.1 Test Requirements

Support structures must satisfy the safety criteria provided in both NCHRP Report No. 350 [1] and AASHTO’s *Standard Specifications for Structural Supports for Highway Signs, Luminaires, and Traffic Signals, Fifth Edition* [2] in order to be accepted by FHWA for use on new construction projects located on the National Highway System (NHS) or as a replacement for existing designs not meeting current safety standards. According to TL-3 of NCHRP Report No. 350, support structures must be subjected to two full-scale vehicle crash tests. The two crash tests are as follows:

1. Test Designation No. 3-60 consisting of a 1,808-lb (820-kg) passenger car impacting the system at a nominal speed of 21.7 mph (35.0 km/h) and an angle between 0 and 20 degrees.
2. Test Designation No. 3-61 consisting of a 1,808-lb (820-kg) passenger car impacting the system at a nominal speed of 62.1 mph (100.0 km/h) and an angle between 0 and 20 degrees.

The test conditions for TL-3 support structures are summarized in Table 3.

Table 3. NCHRP Report No. 350 TL-3 Crash Test Conditions

Test Article	Test Designation	Test Vehicle	Impact Conditions			Evaluation Criteria ¹
			Speed		Angle (deg.)	
			mph	km/h		
Support Structures	3-60	820C	21.7	35.0	0-20	B,D,F,H,I,K,N
	3-61	820C	62.1	100.0	0-20	B,D,F,H,I,K,N

¹ Evaluation criteria explained in Table 4.

Although the tests described in Table 3 pertain to full-scale crash tests with production vehicles, NCHRP Report No. 350 does allow the use of surrogate vehicles, e.g., bogie vehicles or pendulums. For compliance testing, the surrogate vehicle must be properly designed to

replicate the essential properties of the original production model. In 2009, FHWA approved the use of the Valmont-MwRSF/UNL pendulum for the evaluation of breakaway hardware [3]. Therefore, the Valmont-MwRSF/UNL pendulum with crushable nose was used in lieu of a production model vehicle.

In 1975, ENSCO, INC. developed an analytical method for estimating the high-speed (62.1 mph or 100.0 km/h) performance of a breakaway device tested at low-speed (21.7 mph or 35.0 km/h) [4]. Currently, the FHWA recognizes this conservative analytical extrapolation method as an alternative to high-speed, full-scale crash testing [5]. Therefore, only test designation no. 3-60 was performed with the Valmont-MwRSF/UNL pendulum. The results for the high-speed test, corresponding to test designation no. 3-61, were calculated using the analytical extrapolation method.

3.2 Evaluation Criteria

The evaluation criteria were based on three appraisal areas: (1) structural adequacy; (2) occupant risk; and (3) vehicle trajectory after collision. Criteria for structural adequacy are intended to evaluate the predictability of the breakaway support. Occupant risk evaluates the degree of hazard to occupants in the impacting vehicle. Vehicle trajectory after collision is a measure of the potential for the post-impact trajectory of the vehicle to become involved in secondary collisions with other vehicles or fixed objects, thereby increasing the risk of injury to the occupant of the impacting vehicle and to other vehicles. These evaluation criteria are summarized in Table 4 and defined in greater detail in NCHRP Report No. 350.

In tests of breakaway features, the impulse event on the vehicle may be relatively small and of short duration. In such tests, it is not unusual for the hypothetical occupant to travel less than the necessary distance to contact the interior compartment during the period in which accelerations are recorded or up to the time the vehicle loses contact with the test article. In such

cases, the vehicle's change in velocity that occurs during contact with the test article or parts thereof should be reported instead of occupant impact velocity. If parts of the test article remain in contact with the vehicle after impact, the vehicle's change in velocity should be computed at the time in which the vehicle clears the footing or foundation of the test article.

It was recognized that the extent of vehicle roof crush cannot be evaluated when using a bogie vehicle or pendulum for testing. However, breakaway poles weighing less than 992 lb (450 kg) have been shown to pose minimal threat to the occupant compartment. Video of the surrogate vehicle testing can be used to show that the vehicle passes underneath the pole before the luminaire and the top of the pole fall to the ground, demonstrating a minimal risk of roof crush. Therefore, a full evaluation of roof crush has not been required for systems weighing less than 992 lb (450 kg) limit.

Table 4. Evaluation Criteria for Breakaway Support Structures

NCHRP Report No. 350 Criteria			
Structural Adequacy	B. The test article should readily activate in a predictable manner by breaking away, fracturing, or yielding.		
Occupant Risk	D. Detached elements, fragments or other debris from the test article should not penetrate or show potential for penetrating the occupant compartment, or present an undue hazard to other traffic, pedestrians, or personnel in a work zone. Deformations of, or intrusions into, the occupant compartment that could cause serious injury should not be permitted. See discussion in Section 5.3 and Appendix E of NCHRP Report No. 350.		
	F. The vehicle should remain upright during and after collision although moderate roll, pitch, and yaw are acceptable.		
	H. Occupant Impact Velocity (OIV) (see Appendix A, Section A5.3 of NCHRP Report No. 350 for calculation procedure) should satisfy the following:		
	Occupant Impact Velocity Limits		
	Component	Preferred	Maximum
	Longitudinal	9.8 ft/s (3.0 m/s)	16.4 ft/s (5.0 m/s)
Occupant Risk	I. The Occupant Ridedown Acceleration (ORA) (see Appendix A, Section A5.3 of NCHRP Report No. 350 for calculation procedure) should satisfy the following:		
	Occupant Ridedown Acceleration Limits		
	Component	Preferred	Maximum
	Longitudinal and Lateral	15 g's	20 g's
Vehicle Trajectory	K. After collision it is preferable that the vehicle's trajectory not intrude into adjacent traffic lanes.		
	N. Vehicle trajectory behind the test article is acceptable.		
AASHTO Fifth Edition Additional Criteria			
Structural Adequacy	Substantial remains of breakaway supports shall not project more than 4 in. (100 mm) above a line between straddling wheels of a vehicle on 60 in. (1,500 mm) centers. The line connects any point on the ground surface one side of the support to a point on the ground surface on the other side, and it is aligned radially or perpendicularly to the centerline of the roadway.		
	The maximum mass of combined luminaire support and fixtures attached to breakaway supports shall be limited to 992 lb (450 kg). Any increases in these limits are to be based on full-scale crash testing and an investigation of the range of vehicle roof crush characteristics that go beyond the recommended testing procedures of NCHRP Report No. 350.		

4 TEST CONDITIONS

4.1 Testing Facility

The pendulum testing facility is located at Valmont Industries, Inc. in Valley, Nebraska. The facility consists of the pendulum and a utility building for use in control and setup of the testing.

4.2 Data Acquisition Systems

4.2.1 Accelerometers

Two environmental shock and vibration sensor/recorder systems were used to measure the accelerations in the longitudinal direction. The accelerometer systems were mounted on a rigid plate on top of the pendulum body at the longitudinal center-of-gravity. The acceleration data was processed using both SAE CFC 60 and CFC 180 filtering procedures.

The primary accelerometer system was a two-arm piezoresistive accelerometer system manufactured by Endevco of San Juan Capistrano, California. Two accelerometers were used to measure the longitudinal acceleration at a sample rate of 10,000 Hz. The accelerometers were configured and controlled using a system developed and manufactured by Diversified Technical Systems, Inc. (DTS) of Seal Beach, California. More specifically, data was collected using a DTS Sensor Input Module (SIM), Model TDAS3-SIM-16M. The SIM was configured with 16 MB SRAM memory and 8 sensor input channels with 250 kB SRAM/channel. The SIM was mounted on a TDAS3-R4 module rack. The module rack was configured with isolated power/event/communications, 10BaseT Ethernet and RS232 communication, and an internal backup battery. Both the SIM and module rack were crashworthy. The “DTS TDAS Control” computer software program and a customized Microsoft Excel worksheet were used to analyze and plot the accelerometer data.

The second system, Model EDR-3, was a triaxial piezoresistive accelerometer system manufactured by IST of Okemos, Michigan. The EDR-3 was configured with 256 kB of RAM memory, a range of ± 200 g's, a sample rate of 3,200 Hz, and a 1,120 Hz low-pass filter. The "DynaMax 1 (DM-1)" computer software program and a customized Microsoft Excel worksheet were used to analyze and plot the accelerometer data.

The original FOIL-FHWA pendulum testing into a rigid pole used accelerometers on both the crushable nose and the body of the pendulum. This setup was used to measure the accelerations of the two separate masses in the system. During the pendulum impact into a rigid pole, there was an initial impact that stopped the forward motion of the crushable nose and brought the nose velocity to zero. This impact event was very short and had a relatively low magnitude. The remainder of the impact event consisted of deceleration of the main body of the pendulum which was much higher in magnitude. As such, the researchers believed that there would be very little error if the crushable nose accelerations were omitted. This assumption seemed to be proven based on review of the test report for the validation of the TTI pendulum system [8]. In the noted report, TTI showed cross-plots of the pendulum body acceleration and the combined body and crushable nose acceleration. The minor differences between the acceleration curves were relegated to the initial portion of the impact event. Recognizing this, the Valmont-MwRSF/UNL pendulum was certified and validated against a rigid pole without an acceleration transducer system on the crushable nose [3]. Therefore, the current pendulum testing and evaluation program only utilized accelerometers mounted to the pendulum mass.

4.3 Photography Cameras

Three AOS X-PRI high-speed digital video cameras and three JVC digital video cameras were utilized to film test nos. BBC-1 and BBC-2. The three high-speed cameras and two digital video cameras were set up perpendicular to impact at a distance of 55 ft (16.8 m) from the pole.

The other digital video camera was located 55 ft (16.8 m) perpendicular and the pole 49 ft (14.9 m) downstream from the impact. Camera details, lens information, and camera operating speeds are shown in Table 5.

A similar setup as used for test nos. BBC-1 and BBC-2 was utilized for test nos. BBC-3 through BBC-5, except the other digital video camera was located 86 ft (26.2 m) laterally on the opposite side of impact and 60 ft (18.3 m) downstream. Camera details, lens information, and camera operating speeds are shown in Table 6.

During test nos. BBC-6 and BBC-7, only two high-speed cameras and three digital video cameras were used to document the tests. The distance from impact to the perpendicular cameras was 56 ft – 6 in. (17.2 m). The offset digital video camera was located an additional 78 ft (23.8 m) downstream from impact. Camera details, lens information, and camera operating speeds are shown in Table 7.

The high-speed videos were analyzed using a Redlake MotionScope software program. Actual camera speed and camera divergence factors were considered in the analysis of the high-speed videos. A Nikon D50 digital still camera was also used to document pre- and post-test conditions for each test.

Table 5. Camera Data, Test Nos. BBC-1 and BBC-2

	No.	Type	Operating Speed (frames/sec)	Lens	Lens Setting
High-Speed Video	5	AOS X-PRI Gigabit	1000	Fujinon Fixed 50 mm	-
	6	AOS X-PRI Gigabit	500	Sigma Fixed 50 mm	-
	7	AOS X-PRI Gigabit	500	Sigma 24-135	135
Digital Video	2	JVC – GZ-MG27U (Everio)	29.97		
	3	JVC – GZ-MG27U (Everio)	29.97		
	4	JVC – GZ-MG27U (Everio)	29.97		

Table 6. Camera Data, Test Nos. BBC-3 through BBC-5

	No.	Type	Operating Speed (frames/sec)	Lens	Lens Setting
High-Speed Video	5	AOS X-PRI Gigabit	500	Fujinon Fixed 50 mm	-
	6	AOS X-PRI Gigabit	1000	Sigma 24-70	50
	7	AOS X-PRI Gigabit	500	Sigma 24-135	135
Digital Video	3	JVC – GZ-MG27U (Everio)	29.97		
	4	JVC – GZ-MG27U (Everio)	29.97		

Table 7. Camera Data, Test Nos. BBC-6 and BBC-7

	No.	Type	Operating Speed (frames/sec)	Lens	Lens Setting
High-Speed Video	6	AOS X-PRI Gigabit	1000	Fujinon Fixed 50 mm	-
	7	AOS X-PRI Gigabit	500	Osawa 28-80	45
Digital Video	2	JVC – GZ-MG27U (Everio)	29.97		
	3	JVC – GZ-MG27U (Everio)	29.97		
	4	JVC – GZ-MG27U (Everio)	29.97		

4.4 Speed Trap, Wooden Dowels

For all pendulum tests reported herein, three wooden dowels, spaced at 18-in. (457-mm) intervals, were used to determine the speed of the pendulum mass before impact. The dowels were mounted so that the undercarriage of the pendulum body would incrementally impact all three dowels just prior to impact with the pole system. The pendulum speed was then determined from the high-speed video (at 1000 frames/sec) by determining the times at which each dowel was impacted. A photograph of the speed trap setup is shown in Figure 12.



Figure 12. Wooden Dowel Setup

5 TEST INSTALLATION DETAILS – ROUND 1

Two tests were performed in Round 1, test nos. BBC-1 and BBC-2. Each test installation was comprised of a luminaire pole, arms, simulated luminaires, breakaway couplings, and a simulated rigid foundation, as shown in Figures 13 through 22. Each component is described separately in the following sections. The fully assembled test installations for the Round 1 testing program are shown in Figures 23 and 24. Material specifications, mill certifications, and certificates of conforming are shown in Appendix A.

5.1 Luminaire

Critical luminaire pole systems were selected for testing and evaluation in order to allow for other pole configurations to be accepted for use with the breakaway brass couplings, pending a successful testing program. To define the limits of use for the brass couplers, two separate tests were required. One test configuration would represent the worst-case condition for evaluating occupant risk, i.e., the highest change in velocity. A heavy pole system with high rotational inertia would require the most energy to rotate it away from an impacting vehicle, thus resulting in the highest reduction in the vehicle's longitudinal velocity. Therefore, the ILDOT selected a tall, thick, and heavy steel pole to serve as this worst case luminaire system. On the other end of the pole spectrum, a very lightweight, thin-gauge pole may not be strong enough to transfer the impact load down to the couplings. Thus, a weak pole may bend, crush, or fracture before the couplings break away. Therefore, the ILDOT selected a short, thin, and light aluminum pole to serve as this worst-case luminaire pole system. Each pole is described independently in the following sections.

5.1.1 Heavy Steel Luminaire Pole, Test No. BBC-1

The round steel pole was fabricated with a 10-gauge (3.42-mm) wall thickness and had a shaft height of 50 ft (15.2 m), as shown in Figure 13. The nominal height to the luminaire was 53

ft (16.2 m). The pole had a top outside diameter of 4 in. (102 mm) and a bottom outside diameter of 11 in. (279 mm). The two mounting points for attaching the luminaire arms were located 47 ft - 4 in. (14.4 m) and 49 ft - 7 in. (15.1 m) above the base of the pole. The base plate was 1¼-in. (16-mm) thick by 15.1-in. (384-mm) square, as shown in Figure 14. The bolt circle was 15⅞-in. (384-mm) in diameter. Dual truss arms were attached to the top of the pole, each with a length of 12 ft (3.7 m), as shown in Figure 15. Each arm was braced with two struts at locations of 4 ft and 8 ft (1.2 m and 2.4 m) laterally from the pole. Steel plates weighing approximately 50 lb (23 kg) were attached to the end of each arm to simulate the luminaire bulb weights. The pole and base plate weighed 603 lb (274 kg), and the two luminaire arms, with simulated luminaire, weighed 376 lb (171 kg) for a total system weight of 979 lb (444 kg).

5.1.2 Light Aluminum Luminaire Pole, Test No. BBC-2

The round aluminum pole was fabricated with a ¼-in. (6.4-mm) wall thickness and had a height of 27 ft - 8 in. (8.4 m), as shown in Figure 16. The nominal height to the luminaire was 30 ft (9.1 m). The pole had a top outside diameter of 4½ in. (114 mm) and a bottom outside diameter of 8 in. (203 mm). A handhole was located on the pole centered at a height of 18 in. (457 mm) from the base of the pole. The base assembly was 12-in. (305-mm) square and was welded to the base of the pole. The bolt circle had a diameter of 11 in. (279 mm). A single 68-in. (1,727-mm) long luminaire arm was attached to the top of the pole, as shown in Figure 17. Steel plates weighing approximately 50 lb (23 kg) were attached to the end of the arm to simulate the luminaire bulb weight. The pole weighed 169 lb (77 kg), and the luminaire arm, with simulated luminaire, weighed 88 lb (40 kg) for a total system weight of 257 lb (117 kg).

5.2 Breakaway Brass Couplings, Test Nos. BBC-1 and BBC-2

Four ASTM B16 brass breakaway couplings were used to fasten the poles to the foundation in test nos. BBC-1 and BBC-2, as shown in Figures 18 and 19. The 1½-in. (38-mm)

wide hexagon-shaped couplings were 3½ in. (89 mm) tall and had a 0.15-in. (3.8-mm) deep, 1/8-in. radius notch cut around the middle. The couplings were drilled and tapped to provide 1 in. -8 UNC internal threads through the entire length of the coupling. A 3-in. (76-mm) long by 1-in. (25-mm) diameter stainless steel threaded rod was inserted and epoxied into one end of the coupling, leaving 1 in. (25 mm) of the rod exposed.

To prevent the anchor bolts from extending through the critical notched area of the coupling, a nylon insert was inserted inside the coupling. The threaded nylon insert was ½ in. (13 mm) long by 1-in. (25-mm) diameter, as shown in Figure 20. A single groove was cut into one end of the insert so that it could be fastened into the coupling using a screwdriver. The nylon inserts were only used in test no. BBC-1.

5.3 Simulated Rigid Foundation

The base of each pole was bolted to a simulated rigid foundation consisting of a steel W18x119 (W457x177) support beam and two adapter plates, as shown in Figures 21 and 22. The steel support beam had two 1-in. (25-mm) plates reinforcing its web at midspan, and the beam spanned across an 8-ft long by 13-ft wide by 6-ft deep (2.4-m long by 4.0-m wide by 1.8-m deep) concrete pit. Two 36-in. (914-mm) diameter steel adapter plates were bolted to the top flange of the beam at midspan. The adapter plates were bolted to the simulated rigid foundation using 1-in. (25 mm) diameter, ASTM A325 bolts. Finally, the couplings were anchored to the adapter plates using 1-in. (25 mm) diameter, ASTM A325 threaded rods.

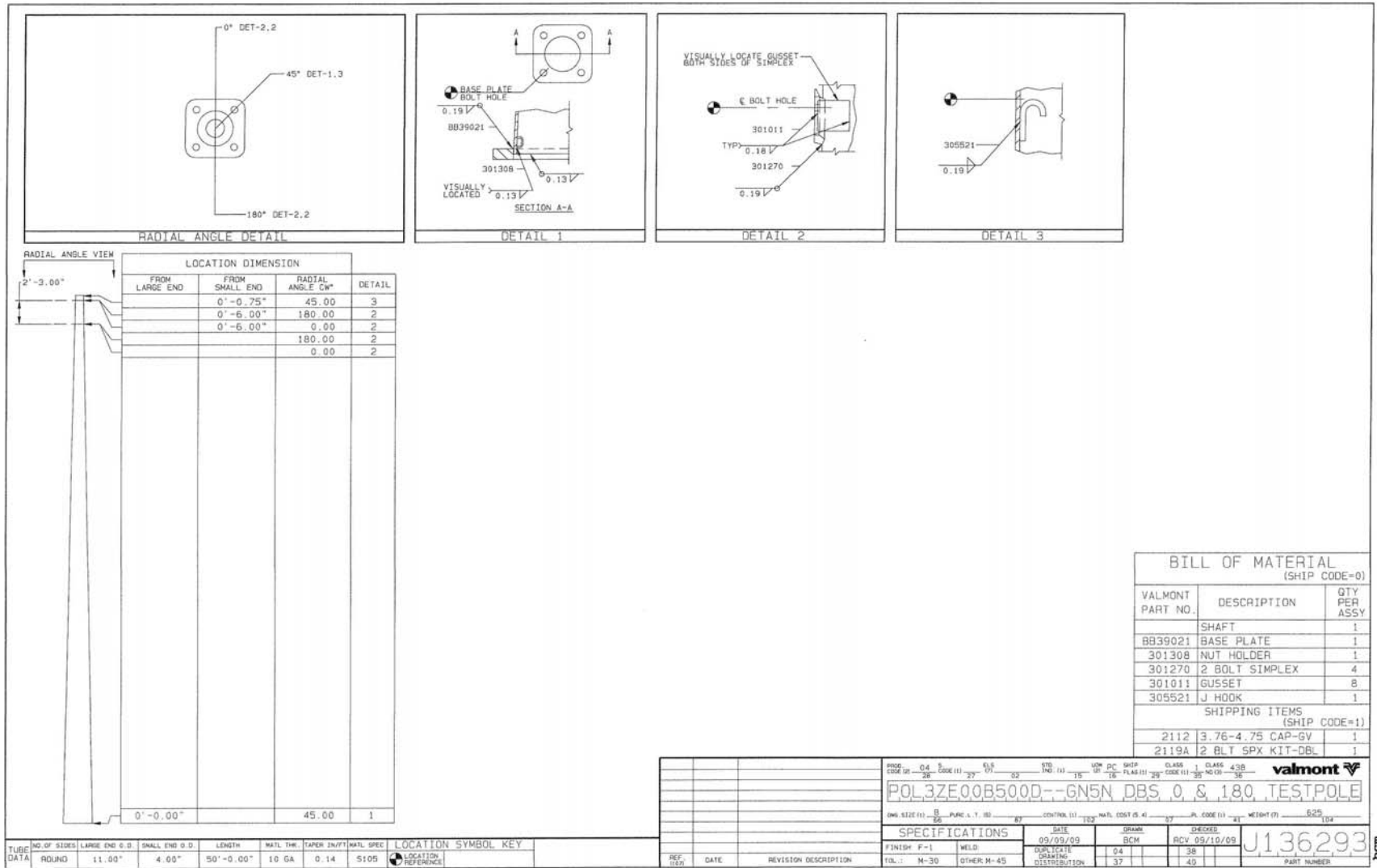

Figure 13. Steel Pole Details, Test Nos. BBC-1, BBC-3, and BBC-4

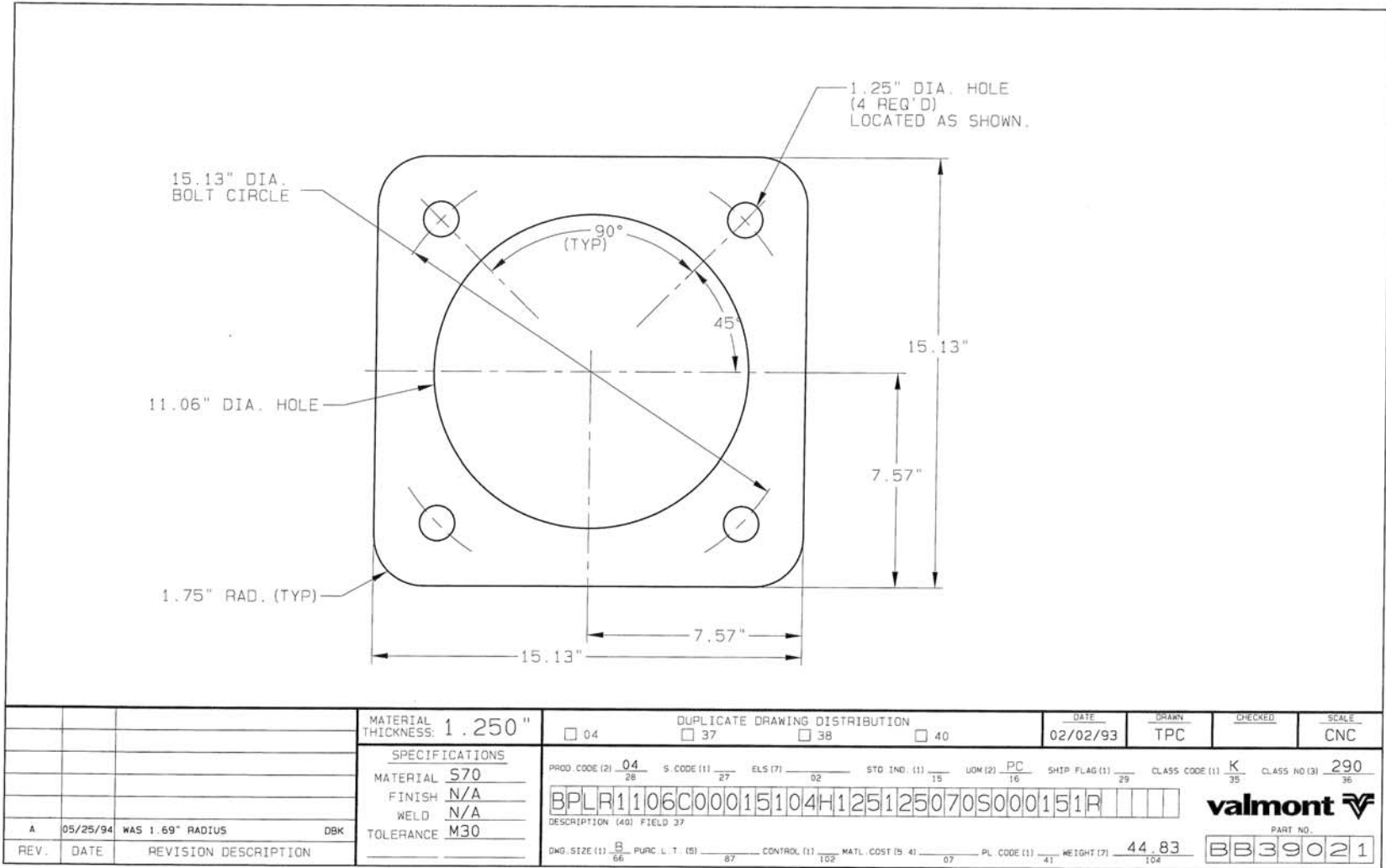

Figure 14. Steel Pole Base Details, Test Nos. BBC-1, BBC-3, and BBC-4

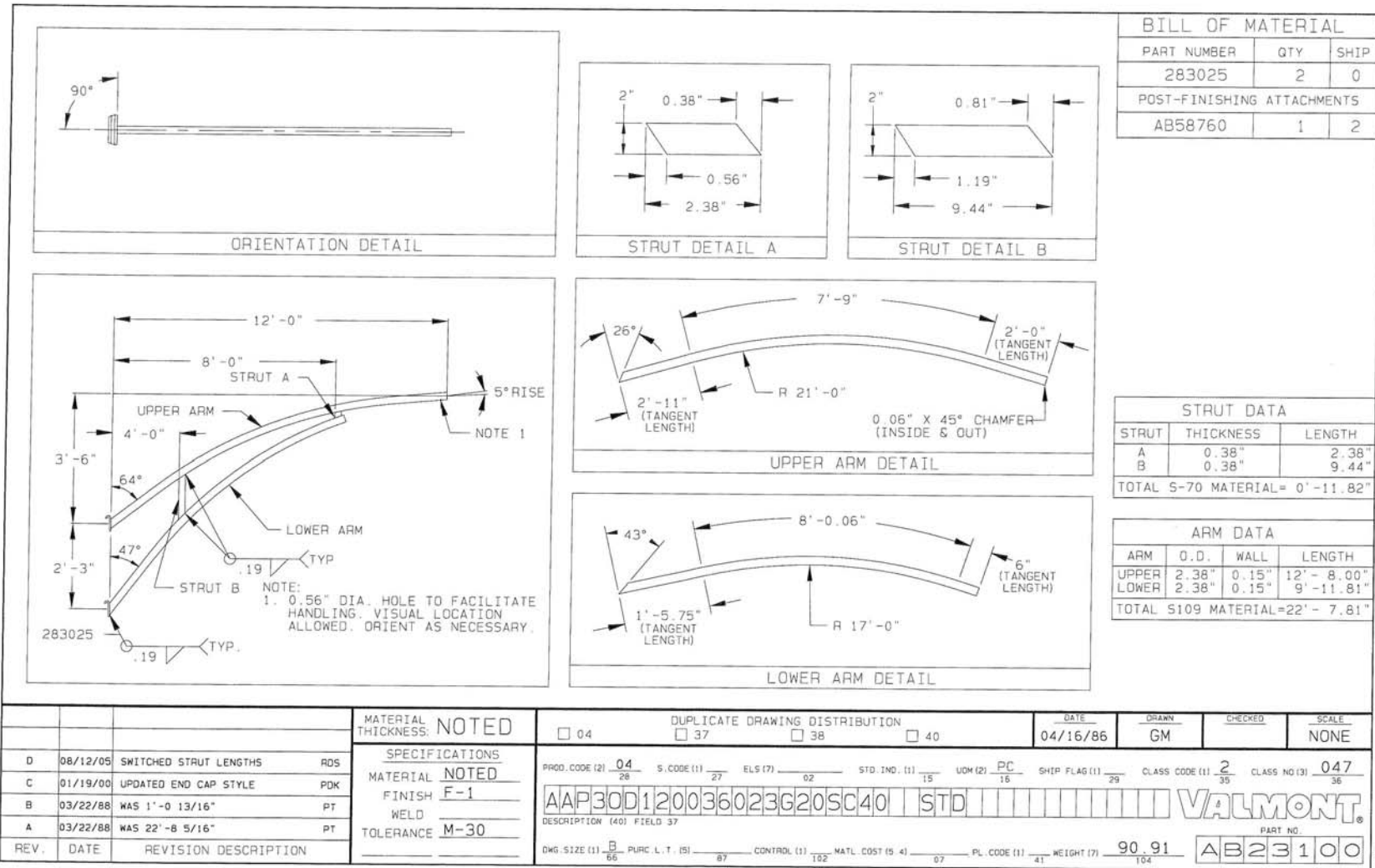

Figure 15. Steel Truss Arm Details, Test Nos. BBC-1, BBC-3, and BBC-4

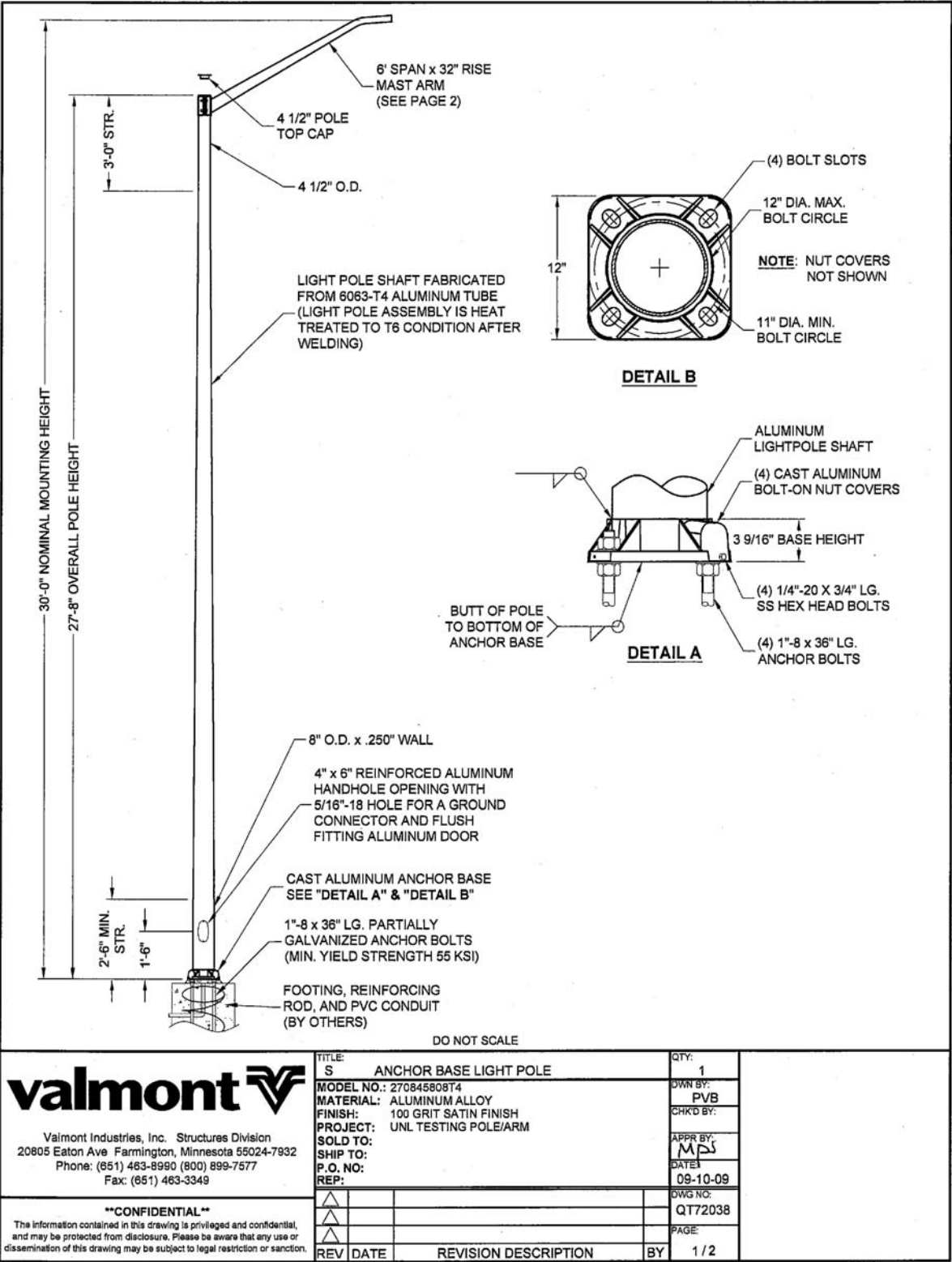

Figure 16. Aluminum Pole Details, Test Nos. BBC-2 and BBC-5

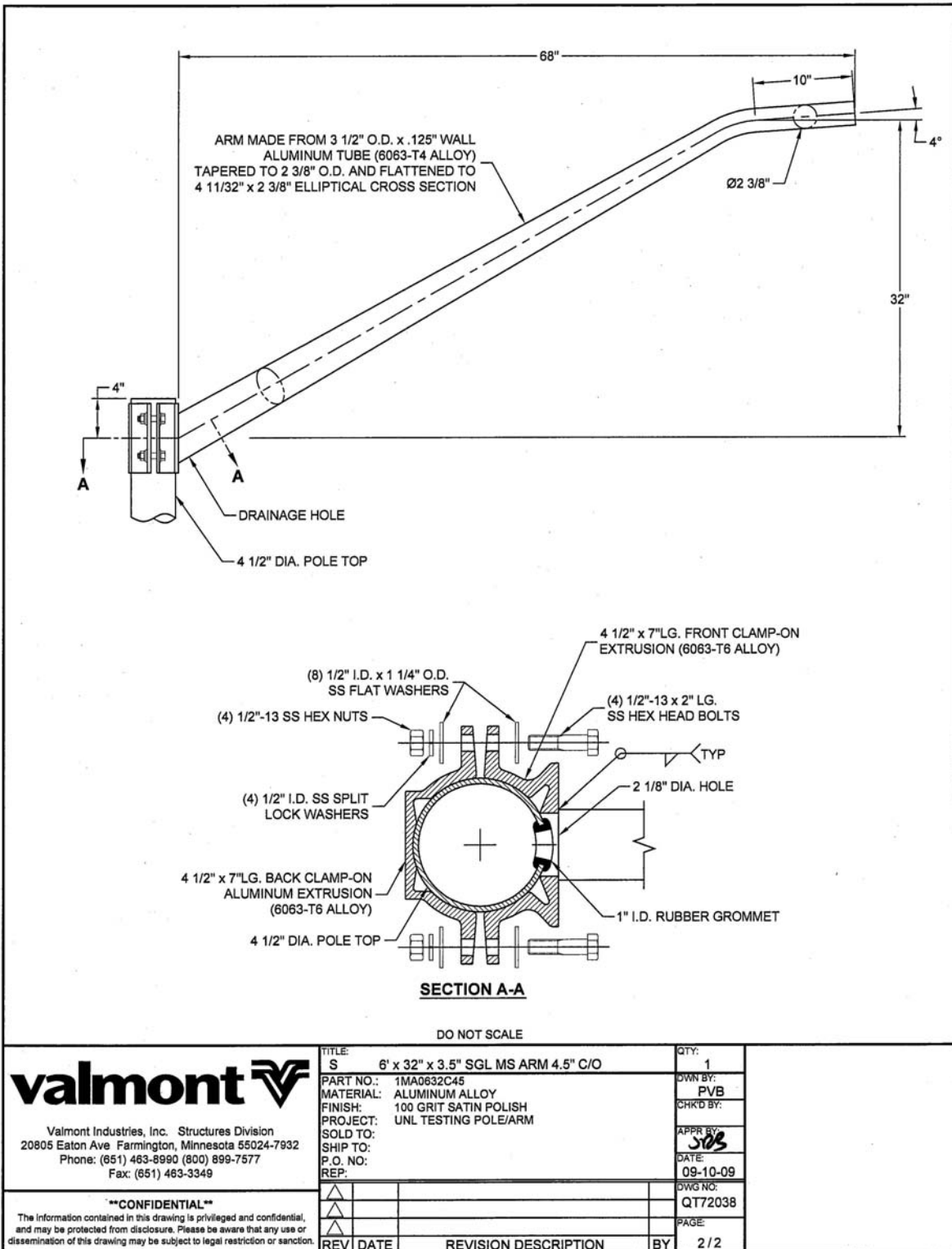

Figure 17. Aluminum Luminaire Arm Details, Test Nos. BBC-2 and BBC-5

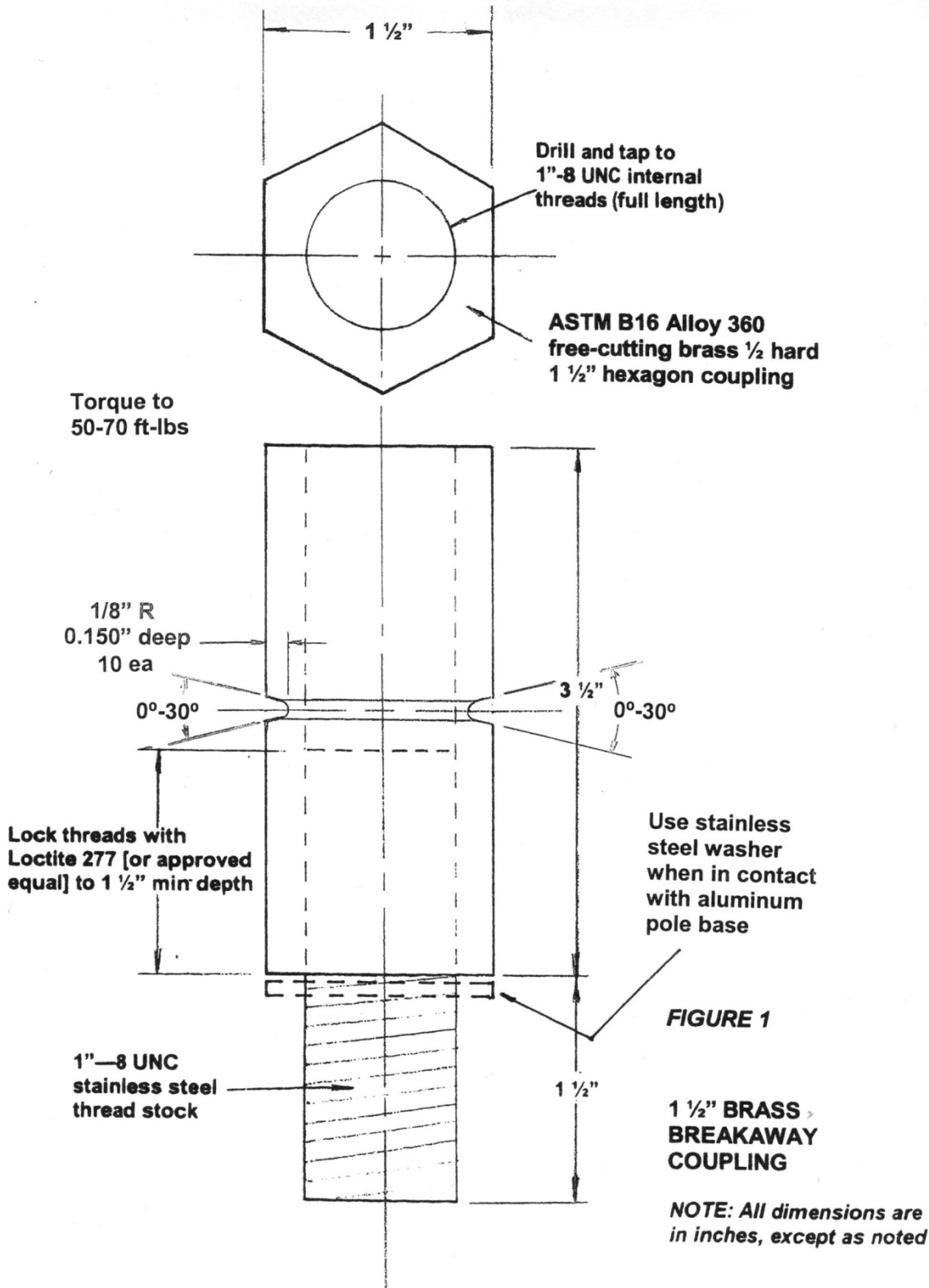

Figure 18. Breakaway Brass Coupling (Version 1) Details, Test Nos. BBC-1 and BBC-2



Figure 19. Brass Couplings (Version 1), Test Nos, BBC-1 and BBC-2



Figure 20. Nylon Inserts for Brass Couplings, Test No. BBC-1

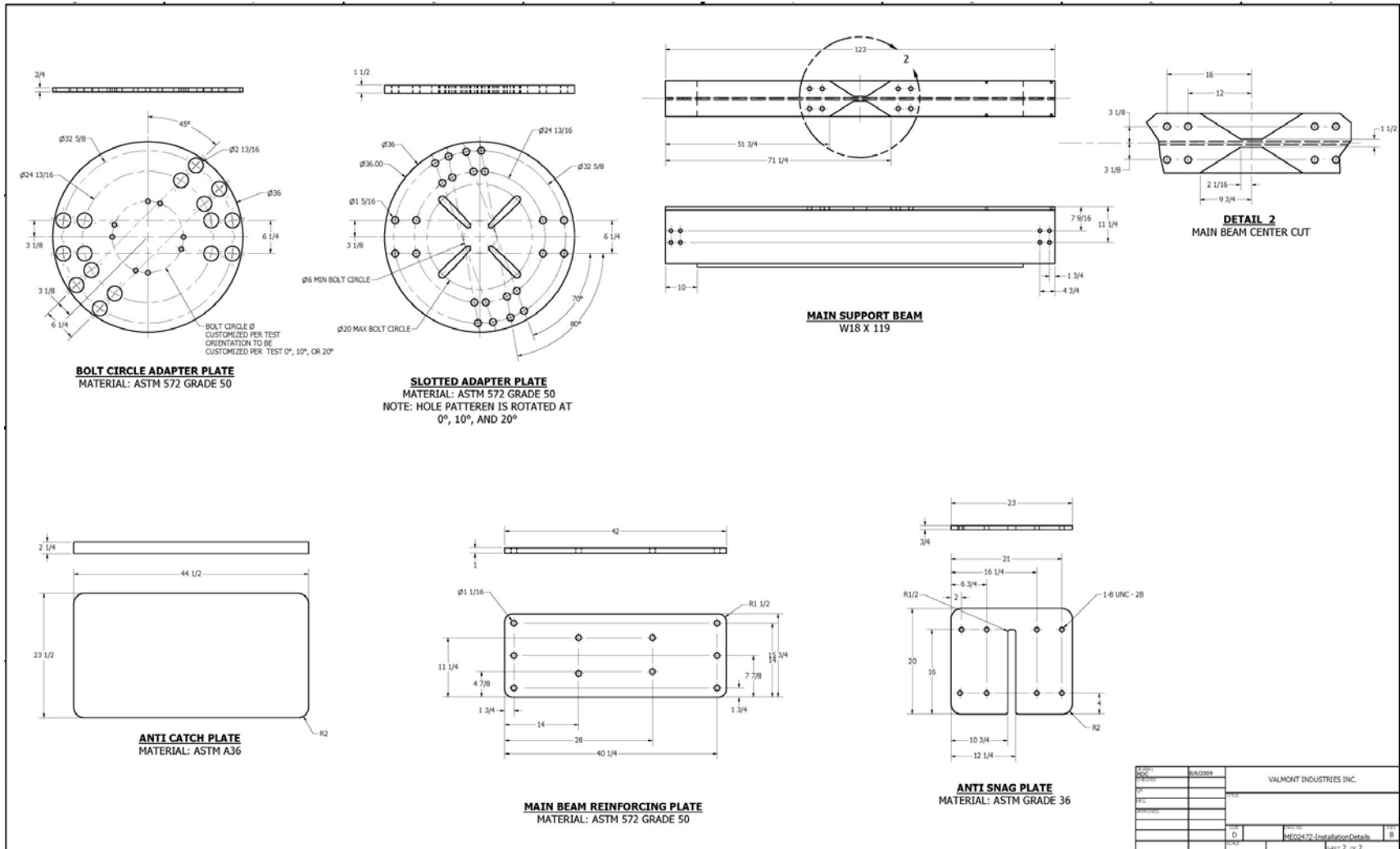



Figure 23. Assembled Test Installation, Test No. BBC-1





Figure 24. Assembled Test Installation, Test No. BBC-2



6 PENDULUM TEST NO. BBC-1

6.1 Test No. BBC-1

The 1,878-lb (852-kg) pendulum with crushable nose impacted the 53-ft (16.2-m) nominal height steel pole with brass couplings at a speed of 21.8 mph (35.1 km/h). A summary of the test results and sequential photographs are shown in Figure 25. Additional sequential photographs are shown in Figures 26 and 27.

6.2 Weather Conditions

Test no. BBC-1 was conducted on November 17, 2009 at approximately 12:30 pm. The weather conditions, as per the National Oceanic and Atmospheric Administration (station 04924/FET), were documented and are shown in Table 8.

Table 8. Weather Conditions, Test No. BBC-1

Temperature	48° F
Humidity	37%
Wind Speed	7 mph
Wind Direction	0° from True North
Sky Conditions	Clear
Visibility	10 Statute Miles
Pavement Surface	Dry
Previous 3-Day Precipitation	0.03 in.
Previous 7-Day Precipitation	0.03 in.

6.3 Test Description

The pendulum impacted the pole system at the targeted impact height of 17½ in. (445 mm). A sequential description of the impact events is contained in Table 9.

Table 9. Sequential Description of Impact Events, Test No. BBC-1

Time (sec)	Event Description
0.000	The pendulum impacted the steel pole, and honeycomb element no. 1 began to compress.
0.005	Honeycomb element no. 2 began to compress.
0.014	Honeycomb element no. 2 was fully compressed, and honeycomb element no. 3 began to compress.
0.023	Honeycomb element no. 3 was fully compressed, and honeycomb element no.4 began to compress.
0.031	Honeycomb element no. 4 was fully compressed, and honeycomb element no. 5 began to compress.
0.034	Honeycomb element no. 6 began to compress.
0.039	Honeycomb element no. 5 was fully compressed.
0.045	Honeycomb element no. 6 was fully compressed, and honeycomb element no. 7 began to compress.
0.050	The pole dented at the impact location. The front of the pendulum pitched downward.
0.055	Honeycomb element no. 7 was fully compressed, and honeycomb element no. 8 began to compress.
0.070	Honeycomb element no. 8 was fully compressed, and honeycomb element no. 9 began to compress.
0.082	The front, or impact-side, couplings fractured, but the pole did not break away.
0.117	The pendulum began to rebound back away from the pole.
0.180	The nose of the pendulum lost contact with the pole. The top of the pole was oscillating back and forth.
1.200	The pole continued to oscillate and was now leaning backward.
3.180	The rear couplings fractured in bending due to the pole falling backward.
5.690	The pole was horizontal as the top fell to the ground behind and directly in line with the impact.

6.4 System Damage

Damage to the luminaire pole and brass couplings is shown in Figures 28 and 29. The steel pole was dented at the impact height. The steel pole and truss arms remained intact and

came to rest lying with the base 6 ft - 2 in. (1.8 m) downstream from impact. All four couplings fractured and left stub heights of 1¾ in. (44 mm), as shown in Figure 28. All four of the nylon inserts were also fractured into two pieces.

6.5 Occupant Risk

The calculated occupant impact velocity (OIV) and maximum 0.010-sec occupant ridedown acceleration (ORA) in the longitudinal direction are shown in Table 10. The calculated longitudinal ORA of -2.06 g's was within the acceptable limits. However, the calculated longitudinal OIV of -35.37 ft/s (-10.78 m/s) exceeded the maximum allowable NCHRP Report No. 350 limits of 16.4 ft/s (5.0 m/s). The recorded data from the accelerometers are shown in graphical format in Appendix B.

Table 10. Occupant Risk Summary, Test No. BBC-1

Evaluation Criteria	Transducer			NCHRP Report No. 350 Limit
	EDR-3	DTS		
		BR39H	CM54H	
Longitudinal OIV ft/s (m/s)	-34.45 (-10.50)	-35.37 (-10.78)	-35.17 (-10.72)	≤ 16.4 (5.00)
Longitudinal ORA g's	-1.40	-2.06	-1.94	≤ 20

6.6 Discussion

During test no. BBC-1, the 53-ft (16.2-m) nominal height steel luminaire pole with brass couplings did not break away in a controlled and predictable manner. The two front couplings fractured following impact, but the two rear couplings fractured much later due to the leaning of the pole. All four couplings had a stub height of 1¾ in. (44 mm), thus meeting the 4-in. (100-mm) maximum stub height requirement provided in AASHTO's *Standard Specifications for*

Structural Supports for Highway Signs, Luminaires, and Traffic Signals, Fifth Edition. The calculated longitudinal OIV of -35.37 ft/s (-10.78 m/s) exceeded the maximum allowable limit established by NCHRP Report No. 350. Therefore, test no. BBC-1 (test designation no. 3-60) did not pass the TL-3 safety performance criteria provided in NCHRP Report No. 350.

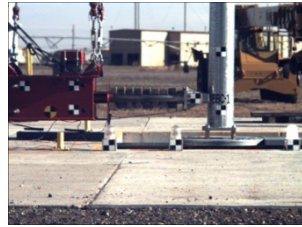

0.000 sec



0.052 sec

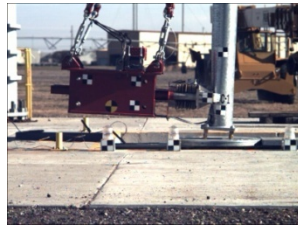

0.084 sec

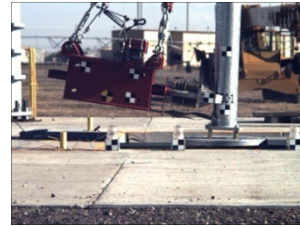

0.117 sec



0.458 sec

- Test Agency MwRSF
- Test Facility..... Valmont-MwRSF/UNL Pendulum
- Test Number..... BBC-1
- Date 11/17/09
- NCHRP Report No. 350 Test Designation No..... 3-60
- Test Article..... Brass Couplings (Version 1) and Steel Pole
- Nominal Luminaire Height 53 ft (16.2 m)
- Key Component – Tapered Steel Pole
 - Height 50 ft (15.2 m)
 - Bottom Diameter 11 in. (279 mm)
 - Thickness..... 10 gauge (3.42 mm)
- Key Component – Luminaire Mast Arms
 - Length..... 12 ft (3.7 m)
 - Mounting Height..... 49 ft – 7 in. (15.1 m)
- Key Component –Couplings
 - Material..... ASTM B16 Brass
 - Shape Hexagon
 - Width 1½ in. (38 mm)
 - Length..... 3½ in. (89 mm)
 - Nylon Insert inside coupling
- Total Installation Mass 979 lb (444 kg)
 - Pole 603 lb (274 kg)
 - Arms 376 lb (171 kg)

- Surrogate Vehicle Pendulum
 - Mass 1,878 lb (852 kg)
 - Impact Head Crushable Nose
- Impact Conditions
 - Speed 21.8 mph (35.1 km/h)
 - Angle 0 deg
 - Impact Height..... 17½ in. (445 mm)
- Test Article Damage Minimal
- Stub Heights
 - Four Occurrences 1¼ in. (44 mm)
- Transducer Data

Evaluation Criteria	Transducer			NCHRP Report No. 350 Limit
	EDR-3	DTS		
		BR39H	CM54H	
Longitudinal OIV ft/s (m/s)	-34.45 (-10.50)	-35.37 (10.78)	-35.17 (-10.72)	≤ 16.4 ft/s (5.0)
Longitudinal ORA g's	-1.40	-2.06	-1.94	≤ 20 g's

Figure 25. Summary of Test Results and Sequential Photographs, Test No. BBC-1



0.000 sec



0.606 sec



0.062 sec



0.734 sec



0.306 sec



0.890 sec



0.416 sec



2.142 sec

Figure 26. Additional Sequential Photographs, Test No. BBC-1



0.000 sec



0.460 sec

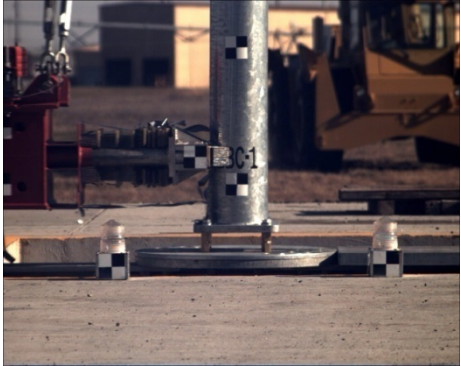

0.056 sec



0.702 sec



0.180 sec



0.856 sec

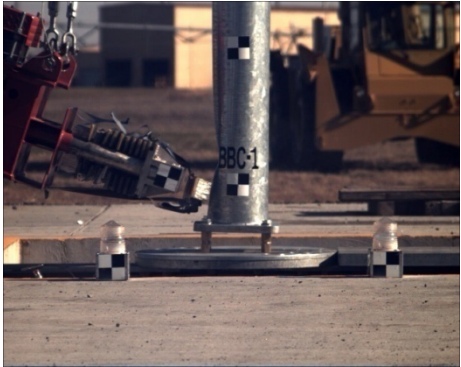

0.304 sec



1.902 sec

Figure 27. Additional Sequential Photographs, Test No. BBC-1



Figure 28. System Damage, Test No. BBC-1



Figure 29. System Damage, Test No. BBC-1

7 PENDULUM TEST NO. BBC-2

7.1 Test No. BBC-2

The 1,878-lb (852-kg) pendulum with crushable nose impacted the 30-ft (9.1-m) nominal height aluminum pole with brass couplings at a speed of 21.8 mph (35.1 km/h). A summary of the test results and sequential photographs are shown in Figure 30. Additional sequential photographs are shown in Figures 31 and 32.

7.2 Weather Conditions

Test no. BBC-2 was conducted on November 17, 2009 at approximately 2:00 pm. The weather conditions, as per the National Oceanic and Atmospheric Administration (station 04924/FET), were documented and are shown in Table 11.

Table 11. Weather Conditions, Test No. BBC-2

Temperature	52° F
Humidity	28%
Wind Speed	9 mph
Wind Direction	340° from True North
Sky Conditions	Clear
Visibility	10 Statute Miles
Pavement Surface	Dry
Previous 3-Day Precipitation	0.03 in.
Previous 7-Day Precipitation	0.03 in.

7.3 Test Description

The pendulum impacted the pole system at the targeted impact height of 17½ in. (445 mm). A sequential description of the impact events is contained in Table 12.

Table 12. Sequential Description of Impact Events, Test No. BBC-2

Time (sec)	Event Description
0.000	The pendulum impacted the aluminum pole, and honeycomb element no. 1 began to compress.
0.007	Honeycomb element no. 2 began to compress.
0.015	Honeycomb element no. 2 was fully compressed, and honeycomb element no. 3 began to compress.
0.023	Honeycomb element no. 3 was fully compressed, and honeycomb element no. 4 began to compress.
0.032	Honeycomb element no. 5 began to compress.
0.040	Honeycomb element no. 6 began to compress, and the pole dented at the impact location.
0.045	Honeycomb element no. 4 was fully compressed, and the right-front coupling fractured.
0.056	Honeycomb element no. 6 was fully compressed.
0.065	The left-front coupling disengaged from the anchor bolt.
0.069	The right-rear coupling fractured.
0.072	The left-rear coupling fractured.
0.093	The left-front coupling, which was still attached to the base plate, fractured after the bottom of the coupling contacted the remaining stub from the left-rear coupling.
0.110	The pendulum lost contact with the luminaire pole, and the pole continued to rotate away its original location.
0.724	The base of the aluminum pole contacted the ground.
1.138	The pendulum impacted the pole on its up swing at a distance of approximately 6 ft (1.8 m) from the base of the pole. This secondary impact caused the pole to rotate at a much quicker rate.
2.500	The luminaire mast arm fell past the rigid base plate and into the pit below.
3.500	The pendulum impacted the luminaire mast arm on its return swing, crushing it against the back wall of the pit and causing extensive deformations to the arm.

7.4 System Damage

Damage to the luminaire pole and brass couplings is shown in Figures 33 and 34. The aluminum pole was dented at the impact height. The luminaire arm was bent significantly from contact with the pendulum during its back swing. The pole and luminaire arm came to rest on top of the pendulum. Three brass couplings fractured as expected, resulting in a remaining stub height of 1¾ in. (44 mm). The other brass coupling was disengaged from its anchor bolt due to the improper installation of the coupling onto the anchor bolt.

7.5 Occupant Risk

The occupant impact velocity (OIV) and maximum 0.010-sec occupant ridedown acceleration (ORA) were not calculated since the hypothetical occupant did not contact the dashboard within the time that the pole was in contact with the vehicle. However, as described in Section 3.2, the pendulum's longitudinal change in velocity throughout the impact event was recorded and compared against the NCHRP Report No. 350 OIV limit. The calculated change in velocity was 16.80 ft/s (5.12 m/s), which exceeded the NCHRP Report No. 350 limit of 16.4 ft/s (5.0 m/s), as shown in Table 13. The recorded data from the accelerometers are shown in graphical format in Appendix C.

Table 13. Occupant Risk Summary, Test No. BBC-2

Evaluation Criteria	Transducer			NCHRP Report No. 350 Limit
	EDR-3	DTS		
		BR39H	CM54H	
Longitudinal OIV ft/s (m/s)	NA (No occupant contact)	NA (No occupant contact)	NA (No occupant contact)	≤ 16.4 (5.0)
Longitudinal ORA g's	NA (No occupant contact)	NA (No occupant contact)	NA (No occupant contact)	≤ 20
Max. Vehicle ΔV ft/s (m/s)	16.52 (5.04)	16.80 (5.12)	16.88 (5.14)	≤ 16.4 (5.0)

7.6 Discussion

The analysis of the results for test no. BBC-2 showed that the 30-ft (9.1-m) nominal height aluminum luminaire pole with brass couplings broke away in a predictable manner. The high-speed video illustrated that the vehicle would pass underneath the pole before the luminaire fell to the ground. Therefore, the pole did not show a propensity to cause excessive deformations to the occupant compartment after it broke away. The change in velocity of the pendulum during impact was 16.88 ft/s (5.14 m/s), which exceeds the 16.4 ft/s (5.0 m/s) limit established by NCHRP Report No. 350. One coupling disengaged from the anchor bolt instead of fracturing. Upon investigation, it was determined that the anchor bolt had only been inserted $\frac{1}{4}$ in (6 mm) into the bottom of the coupling instead of the full $1\frac{1}{2}$ in. (38 mm). As a result, the anchor bolt stripped the threads inside the brass coupling before it fractured. This occurrence may have slightly reduced both the total absorbed energy during the test and the resulting change in velocity. Therefore, test no. BBC-2 (test designation no. 3-60) did not pass the TL-3 safety performance criteria provided in NCHRP Report No. 350.

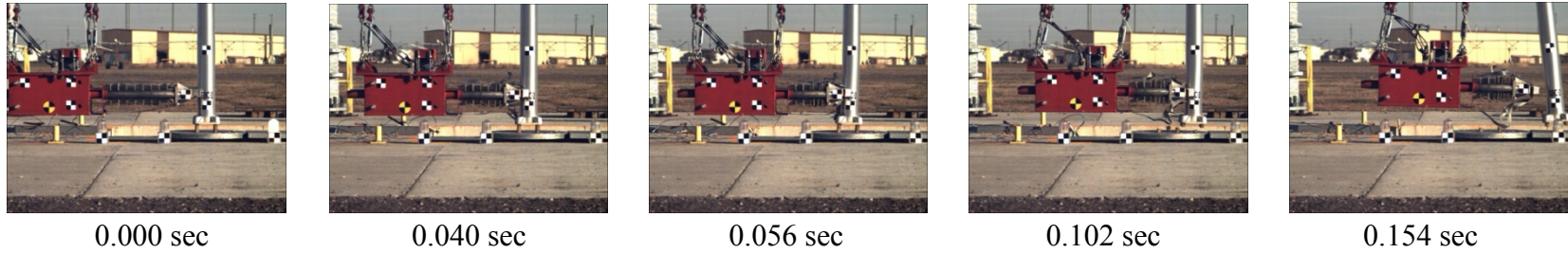

- Test Agency MwRSF
- Test Facility..... Valmont-MwRSF/UNL Pendulum
- Test Number..... BBC-2
- Date 11/17/09
- NCHRP Report No. 350 Test Designation No..... 3-60
- Test Article.. Brass Couplings (Version 1) and Aluminum Pole
- Nominal Luminaire Height 30 ft (9.1 m)
- Key Component – Tapered Aluminum Pole
 - Height 27 ft – 8 in. (8.4 m)
 - Bottom Diameter 8.0 in. (203 mm)
 - Thickness..... ¼ in. (6 mm)
- Key Component – Luminaire Mast Arm
 - Length..... 68 in. (1,727 mm)
 - Mounting Height..... 27 ft – 8 in. (8.4 m)
- Key Component – Couplings
 - Material..... ASTM B16 Brass
 - Shape Hexagon
 - Width..... 1½ in. (38 mm)
 - Length..... 3½ in. (89 mm)
- Total Installation Mass 257 lb (117 kg)
 - Pole..... 169 lb (77 kg)
 - Arm..... 88 lb (40kg)
- Surrogate Vehicle..... Pendulum
 - Mass..... 1,878 lb (852 kg)
 - Impact Head..... Crushable Nose

- Impact Conditions
 - Speed 21.8 mph (35.1 km/h)
 - Angle 0 deg
 - Impact Height..... 17½ in. (445 mm)
- Test Article Damage Moderate
- Stub Heights
 - Four Occurrences 1¾ in. (44 mm)
- Transducer Data

Evaluation Criteria	Transducer			NCHRP Report No. 350 Limit
	EDR-3	DTS		
		BR39H	CM54H	
Longitudinal OIV ft/s (m/s)	NA (No occupant contact)	NA (No occupant contact)	NA (No occupant contact)	≤ 16.4 ft/s (5.0)
Longitudinal ORA g's	NA (No occupant contact)	NA (No occupant contact)	NA (No occupant contact)	≤ 20 g's
Max. Vehicle ΔV ft/s (m/s)	16.52 (5.04)	16.80 (5.12)	16.88 (5.09)	≤ 16.4 ft/s (5.0)

Figure 30. Summary of Test Results and Sequential Photographs, Test No. BBC-2



0.000 sec



0.178 sec



0.026 sec



0.256 sec



0.046 sec



0.282 sec



0.094 sec



0.396 sec

Figure 31. Additional Sequential Photographs, Test No. BBC-2



0.000 sec



0.066 sec



0.016 sec



0.094 sec



0.032 sec

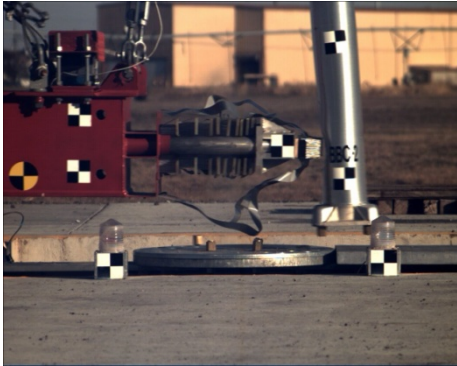

0.124 sec



0.046 sec

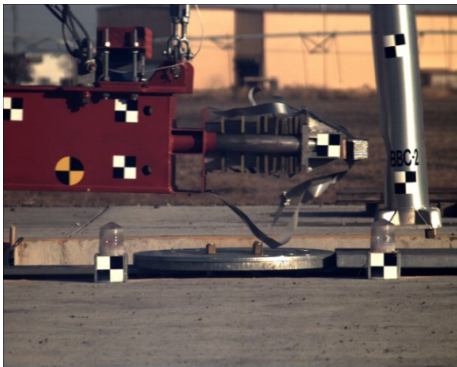

0.168 sec

Figure 32. Additional Sequential Photographs, Test No. BBC-2



Figure 33. System Damage, Test No. BBC-2



Figure 34. System Damage, Test No. BBC-2

8 SUMMARY OF ROUND 1 TESTING

In the first round of testing, the Valmont/MwRSF-UNL pendulum, equipped with a crushable nose, was utilized to conduct two tests for evaluating the first version of the breakaway brass couplings. Both tests failed to satisfy the safety performance criteria established by NCHRP Report No. 350 and AASHTO's *Standard Specifications for Structural Supports for Highway Signs, Luminaires, and Traffic Signals*. A summary of the evaluation for both tests is shown in Table 14.

In test no. BBC-1, the couplings were used to support a 53-ft (16.2-m) nominal height, 10-gauge (3.42-mm) thick, steel luminaire pole. During this test, the pole did not break away as only the front two couplings fractured upon impact. The rear couplings fractured seconds after the impact due to bending forces caused by the pole leaning backward. The sudden stop of the pendulum resulted in OIV values over twice the NCHRP Report No. 350 maximum allowable limit of 16.4 ft/s (5.0 m/s). Upon inspection of the fractured couplings, it was noted that the nylon spacer inserts fractured along with the notched cross section of the brass couplings. The nylon spacer inserts were not a part of the original development testing, but rather a late addition to the couplings meant to ensure that the anchor bolts would not be threaded too far and extend through the notched fracture plane. Therefore, it was determined that the addition of these nylon inserts greatly increased the strength of the brass couplings and prevented the desired breakaway mechanism from activating. Subsequently, the inserts were not utilized in the couplings during no. test BBC-2.

In test no. BBC-2, the couplings were used to support a 30-ft (9.1-m) nominal height, 1/4-in. (6.4-mm) thick, aluminum luminaire pole. During the test, the pole broke away in a controlled manner. However, it was later discovered in the high-speed video that only three of the couplings fractured while the last coupling was pulled from the anchor bolt. Upon investigation, the brass

coupling was not properly installed on the anchor bolt as only $\frac{1}{4}$ in. (6 mm) of the bolt was threaded into the coupling. This embedment proved to be too small, and the internal threads of the coupling were stripped as the coupling was loaded. However, this phenomenon was inconsequential as the longitudinal change in velocity of 16.88 ft/s (5.14 m/s) exceeded the NCHRP Report No. 350 maximum allowable limit of 16.4 ft/s (5.0 m/s). If the fourth coupling had been installed properly and instead fractured, the impact loads would have only been increased.

The first round of pendulum testing illustrated that the brass couplings had reserve strength as both tests resulted in excessive OIVs (or velocity changes). As a result, the breakaway brass couplings were redesigned before the testing and evaluation process was continued. The second version of the brass couplings is described in Chapter 9.

Table 14. Summary of Safety Performance Evaluation Results, Round 1 Testing Program

NCHRP Report No. 350 Criteria			Test No. BBC-1	Test No. BBC-2	
Structural Adequacy	B. The test article should readily activate in a predictable manner by breaking away, fracturing or yielding.		U	S	
Occupant Risk	D. Detached elements, fragments or other debris from the test article should not penetrate or show potential for penetrating the occupant compartment or present an undue hazard to other traffic, pedestrians, or personnel in a work zone. Deformations of, or intrusions into, the occupant compartment that could cause serious injury should not be permitted. See discussion in Section 5.3 and Appendix E of NCHRP Report No. 350.		S	S	
	F. The vehicle should remain upright during and after collision although moderate roll, pitch, and yaw are acceptable.		NA	NA	
	H. Occupant Impact Velocity (OIV) (see Appendix A, Section A5.3 of NCHRP Report No. 350 for calculation procedure) should satisfy the following:		U	U	
	Occupant Impact Velocity Limits				
	Component	Preferred			Maximum
Longitudinal	9.8 ft/s (3.0 m/s)	16.4 ft/s (5.0 m/s)			
I. The Occupant Ridedown Acceleration (ORA) (see Appendix A, Section A5.3 of NCHRP Report No. 350 for calculation procedure) should satisfy the following:	Occupant Ridedown Acceleration Limits		S	NA	
	Component	Preferred			Maximum
	Longitudinal and Lateral	15 g's			20 g's
Vehicle Trajectory	K. After collision it is preferable that the vehicle's trajectory not intrude into adjacent traffic lanes.		NA	NA	
	N. Vehicle trajectory behind the test article is acceptable		S	S	
AASHTO Fifth Edition Additional Criteria					
Structural Adequacy	Substantial remains of breakaway supports shall not project more than 4 in. (100 mm) above a line between straddling wheels of a vehicle on 60 in. (1500 mm) centers. The line connects any point on the ground surface one side of the support to a point on the ground surface on the other side, and it is aligned radially or perpendicularly to the centerline of the roadway.		S	S	
	The maximum mass of combined luminaire support and fixtures attached to breakaway supports shall be limited to 992 lb (450 kg). Any increase in these limits are to be based on full-scale crash testing and an investigation on the range of the roof crush characteristics that go beyond the recommended testing procedures of NCHRP Report No. 350.		S	S	

S- Satisfactory U-Unsatisfactory NA-Not Applicable

9 TEST INSTALLATION DETAILS – ROUND 2

9.1 Breakaway Brass Couplings (Version 2), Test Nos. BBC-3 and BBC-5

Several modifications were made to the original brass coupling (Version 1). First, the nylon inserts were removed from the inside of the couplings. As described in the previous chapter, the inserts proved to greatly increase the coupling capacity, an unintentional and undesirable effect. However, it was still desired to include a mechanism to prevent the anchor bolts from being threaded too far into the brass couplings and within the fracture plane. As a result, a set screw was placed on the side of the coupling $\frac{1}{4}$ in. (6 mm) from the center notch. The set screw prevented the anchor bolts from being threaded more than $1\frac{1}{2}$ in. (38 mm) into the coupling, which ensured the fracture plane would be free and clear within the coupling.

The second modification to the brass coupling involved a reduction in the notch radius from $\frac{1}{8}$ in. (3.2 mm) to 0.075 in. (1.9 mm) and an increase in the notch depth by 0.02 in. (1 mm) to 0.170 in. (4.32 mm). The sharper radius created a higher stress concentration in the notch, while the deeper notch reduced the cross-sectional area of the coupling through the fracture plane. Together, these changes significantly reduced the strength and fracture energy of the brass coupling.

The third modification to the coupling was an extension of the 1-in. (25-mm) diameter stainless steel threaded rod to a length of 4 in. (102 mm). As a result, the threaded rod extended $2\frac{1}{2}$ in. (64 mm) from the top of the coupling. The increased length was necessary for the rod to extend through the thick steel base plates and leave enough room for washers and a nut.

As a result of these three modifications, Version 2 of the brass coupling was developed, as shown in Figure 35. The new coupling was used in test nos. BBC-3 and BBC-5.

9.2 TRANSPO Industries, Inc. Breakaway Coupling, Test No. BBC-4

The ILDOT developed the brass breakaway coupling with the intent to provide similar safety performance and fracture strength to that of the TRANSPO Pole-Safe Double-Neck couplings. These TRANSPO couplings had been previously tested and accepted by FHWA [9-10]. Although the ILDOT couplings performed similarly to the TRANSPO coupling in single component tests, the ILDOT engineers were interested in the dynamic performance of the TRANSPO couplings in actual luminaire pole installations, especially after conducting the unsuccessful Round 1 testing program using the brass couplings. Therefore, test no. BBC-4 was performed on a steel luminaire pole system that was mounted on four 1-in. (25-mm) diameter, TRANSPO Industries, Inc.'s Pole-Safe, Double-Neck couplings, as shown in Figure 36.

9.3 Luminaire Poles

The luminaire poles from the Round 1 testing program were also utilized for the Round 2 testing program. The 53-ft (16.2-m) nominal height, dual arm, steel luminaire pole system was utilized for test nos. BBC-3 and BBC-4, while the 30-ft (9.1-m) nominal height, aluminum luminaire pole system was utilized for test no. BBC-5. Although the poles did receive some minor damage in the form of denting at the impact height, both the steel and aluminum poles remained straight and stood vertical when installed. The poles were rotated 180 degrees and the pendulum impacted the opposite side so that the prior dents would not affect the test results. The aluminum mast arm, which was damaged during test no. BBC-2, had to be replaced with a new part. The steel luminaire used in test nos. BBC-3 and BBC-4 had a total system weight of 923 lb (419 kg), while the aluminum luminaire used in test no. BBC-5 had a total system weight of 259 lb (118 kg). The slight difference in weight between the systems used in Round 1 and the systems of Round 2 was due to a different set of steel plates used to comprise the simulated

luminaire bulb. Photographs of the assembled systems for test nos. BBC-3 through BBC-5 are shown in Figures 37 through 39, respectively.

For test nos. BBC-3 through BBC-5, ropes were used to tether the top of the pole to the pendulum support structure. The ropes allowed the top of the pole to fall about 10 ft (3 m) from its original position before it was caught. Thus, the tether did not inhibit the freefall/rotation of the pole until after the impact event.

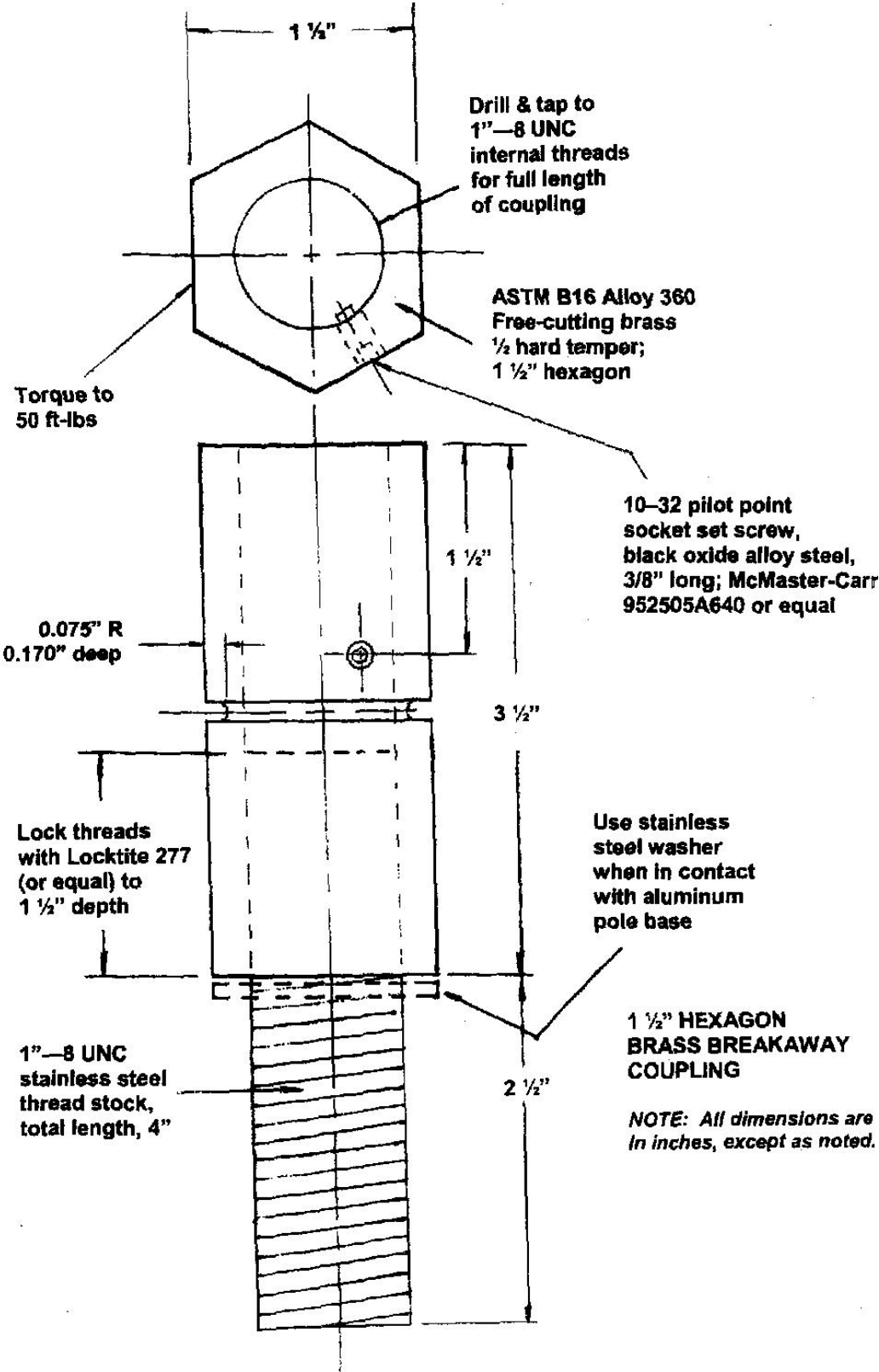
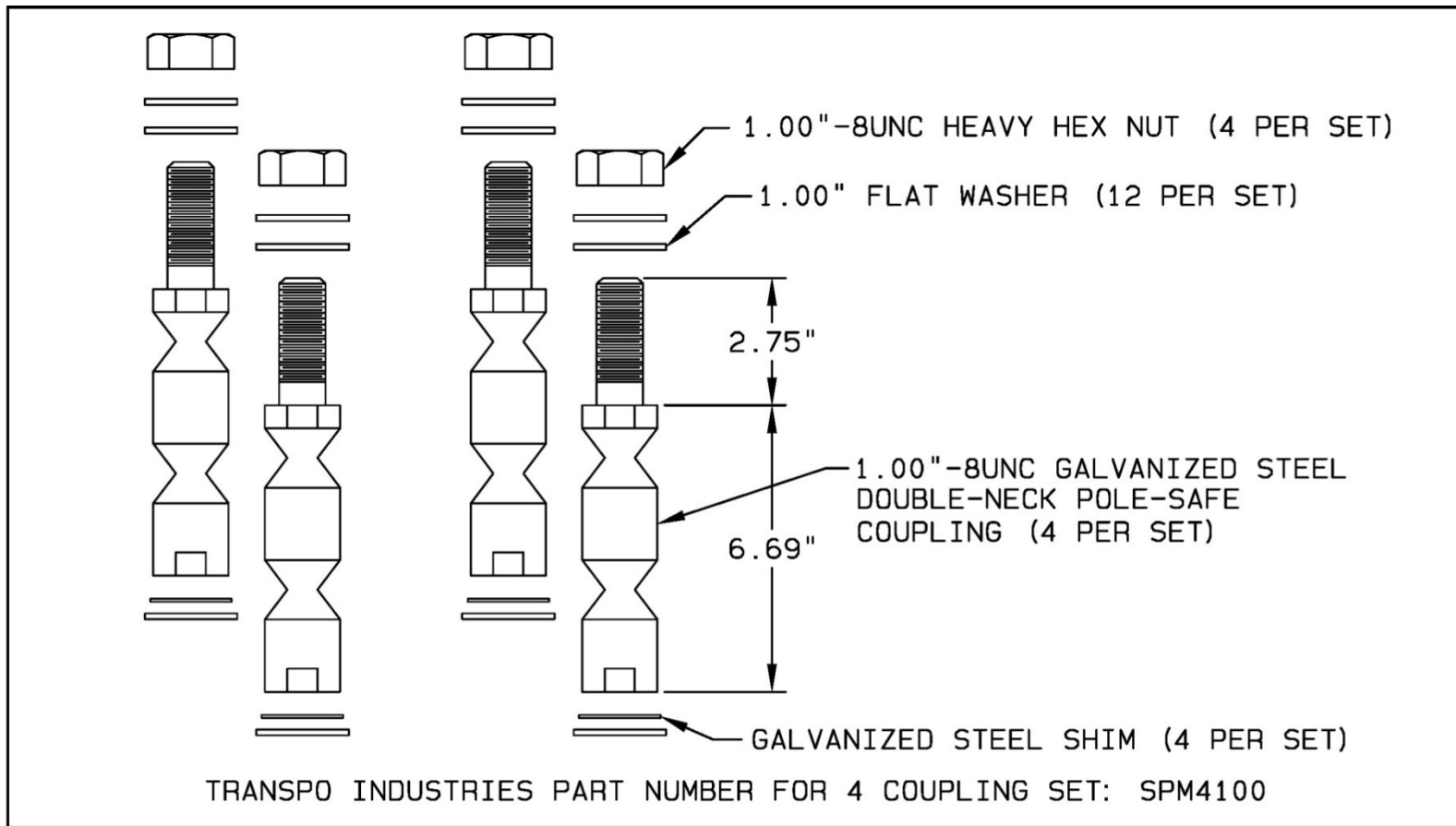

Figure 35. Brass Coupling (Version 2) Detail, Test Nos. BBC-3 and BBC-5



				PROD. CODE (2) <u>04</u>	S. CODE (1) <u>27</u>	ELS (7) <u>02</u>	STD. IND. (1) <u>15</u>	UOM (2) <u>PC</u>	SHIP FLAG (1) <u>29</u>	CLASS CODE (1) <u>T</u>	CLASS NO (3) <u>160</u>	VALMONT.
				LPM BRK WY CPLG SET-STEEL-TRANSPD SPM4100								
B	07/01/05	CHG CPLG DIM WAS 6.19"	PAR	DWG. SIZE (1) <u>A</u>	PURC. L. T. (5) <u>87</u>	CONTROL (1) <u>102</u>	MATL. COST (5.4) <u>37</u>	PL. CODE (1) <u>41</u>	WEIGHT (7) <u>16.00</u>			
A	02/18/00	CHANGE TO 4 CPLG SET	RVC									
REF. (167)	DATE	REVISION DESCRIPTION		MATERIAL THICKNESS	DATE	DRAWN	CHECKED	SCALE	AB63997			
SPECIFICATIONS		MATERIAL: NOTED	TOL.: M-30	N/A	11/18/99	RCV	RCV 11/18/99	NONE				
		FINISH: F2	OTHER:			DUPLICATE DRAWING DISTRIBUTION	04	38				
							37	40	PART NUMBER			

Figure 36. 1-in. (25-mm) Diameter, TRANSPO Pole-Safe Breakaway Coupling Details, Test No. BBC-4



Figure 37. Assembled Test Installation, Test No. BBC-3





Figure 38. Assembled Test Installation, Test No. BBC-4





Figure 39. Assembled Test Installation, Test No. BBC-5



10 PENDULUM TEST NO. BBC-3

10.1 Test No. BBC-3

The 1,849-lb (839-kg) pendulum with crushable nose impacted the 53-ft (16.2-m) nominal height, steel luminaire pole with dual truss arms, simulated luminaire weights, and mounted on brass breakaway couplings (Version 2) at a speed of 21.8 mph (35.1 km/h). A summary of the test results and sequential photographs are shown in Figure 40. Additional sequential photographs are shown in Figures 41 and 42.

10.2 Weather Conditions

Test no. BBC-3 was conducted on June 15, 2010 at 12:10 pm. The weather conditions, as per the National Oceanic and Atmospheric Administration (station 04924/FET), were documented and are shown in Table 15.

Table 15. Weather Conditions, Test No. BBC-3

Temperature	73° F
Humidity	64%
Wind Speed	8 mph
Wind Direction	300° from True North
Sky Conditions	Clear
Visibility	10 Statute Miles
Pavement Surface	Dry
Previous 3-Day Precipitation	3.60 in.
Previous 7-Day Precipitation	8.72 in.

10.3 Test Description

The pendulum impacted the pole system at the targeted impact height of 17½ in. (445 mm). A sequential description of the impact events is contained in Table 16.

Table 16. Sequential Description of Impact Events, Test No. BBC-3

Time (sec)	Event Description
0.000	Impact
0.006	Contact region of honeycomb element no. 1 was fully compressed.
0.016	Honeycomb element no. 2 was fully compressed.
0.024	Honeycomb element no. 3 was fully compressed.
0.032	Honeycomb element no. 4 was fully compressed.
0.042	Honeycomb element no. 5 was fully compressed.
0.048	Honeycomb element no. 7 was fully compressed.
0.058	The front two couplings fractured.
0.062	Honeycomb element no. 6 was fully compressed.
0.066	The rear two couplings fractured.
0.140	The pendulum lost contact with the pole.
0.514	The base of the pole contacted the ground as the pole rotated away from impact.
0.862	The pendulum impacted the pole for a second time on its upswing.
2.172	The top of the pole was caught by the tether ropes.

10.4 System Damage

Damage to the luminaire pole and brass couplings is shown in Figures 43 and 44. The steel pole was dented at the impact height. The base of the pole came to rest 26 ft (7.9 m) downstream from the initial attachment location with the top of the pole captured by the tether. The two mast arms were slightly bent due to the tether system catching the pole as it fell. All four brass couplings fractured through the center notch, resulting in stub heights of 1¼ in. (44 mm).

10.5 Occupant Risk

The occupant impact velocity (OIV) and maximum 0.010-sec occupant ridedown acceleration (ORA) were not calculated since the hypothetical occupant did not contact the dashboard within the time that the pole was in contact with the vehicle. However, as described in Section 3.2, the pendulum’s change in longitudinal velocity throughout the impact event was recorded and compared against the NCHRP Report No. 350 OIV maximum allowable limit of 16.4 ft/s (5.0 m/s). The calculated change in velocity was at the NCHRP Report No. 350 limit, either slightly over or slightly under depending on which transducer system was used, as shown in Table 17. The recorded data from the accelerometers are shown graphically in Appendix D.

Table 17. Occupant Risk Summary, Test No. BBC-3

Evaluation Criteria	Transducer			NCHRP Report No. 350 Limit
	EDR-3	DTS		
		BF57H	CM54H	
Longitudinal OIV ft/s (m/s)	NA (No occupant contact)	NA (No occupant contact)	NA (No occupant contact)	≤ 16.4 (5.0)
Longitudinal ORA g’s	NA (No occupant contact)	NA (No occupant contact)	NA (No occupant contact)	≤ 20
Maximum Vehicle ΔV ft/s (m/s)	16.44 (5.01)	16.40 (5.00)	16.36 (4.99)	≤ 16.4 (5.0)

10.6 Discussion

The analysis of the results for test no. BBC-3 showed that the 53-ft (16.2-m) nominal height, steel luminaire system mounted on Version 2 of the brass couplings broke away in a controlled and predictable manner. The high-speed video illustrated that the vehicle would pass underneath the pole before the luminaire pole system fell to the ground. Therefore, the pole did

not show a propensity to cause excessive deformations to the occupant compartment after it broke away. The change in velocity of the pendulum mass from initial impact until loss of contact with the test article was between 16.36 ft/s and 16.44 ft/s (4.99 m/s and 5.01 m/s), which straddles the NCHRP Report No. 350 maximum allowable limit of 16.4 ft/s (5.0 m/s). Therefore, test no. BBC-3 (test designation no. 3-60) with the Version 2 brass couplings passed or met the TL-3 safety performance criteria provided in NCHRP Report No. 350.

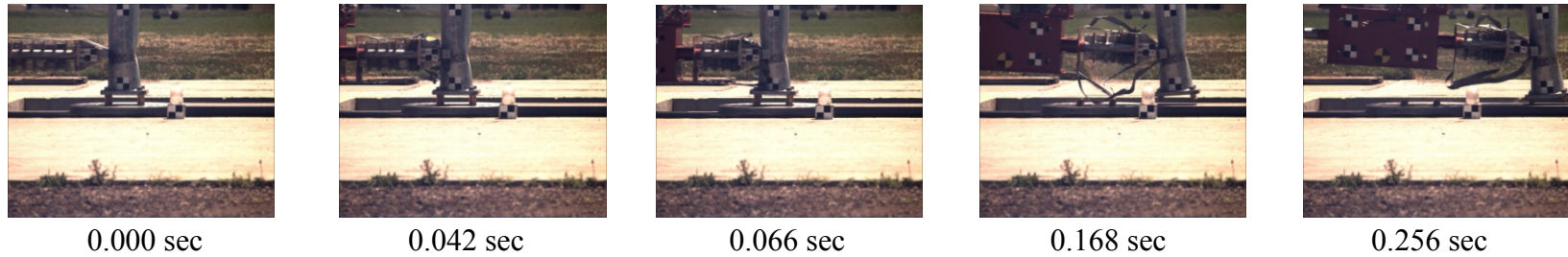

- Test Agency MwRSF
- Test Facility Valmont-MwRSF/UNL Pendulum
- Test Number BBC-3
- Date 6/15/10
- NCHRP Report No. 350 Test Designation No. 3-60
- Test Article Brass Couplings (Version 2) and Steel Pole
- Nominal Height 53 ft (16.2 m)
- Key Component – Tapered Steel Pole
 - Height 50 ft (15.3 m)
 - Bottom Diameter 11 in. (279 mm)
 - Thickness 10-gauge (3.42 mm)
- Key Component – Luminaire Mast Arms
 - Length 12 ft (3.7 m)
 - Mounting Height 49 ft – 7 in. (15.1 m)
- Key Component – Couplings
 - Material ASTM B16 Brass
 - Shape Hexagon
 - Width 1½ in. (38.1 mm)
 - Length 3½ in. (89 mm)
- Total Installation Mass 923 lb (419 kg)
 - Pole 603 lb (273 kg)
 - Arms 321 lb (146 kg)
- Surrogate Vehicle Pendulum
 - Mass 1,849 lb (839 kg)
 - Impact Head Crushable Nose

- Impact Conditions
 - Speed 21.8 mph (35.1 km/h)
 - Angle 0 deg
 - Impact Height 17½ in. (445 mm)
- Test Article Damage Minimal
- Stub Heights
 - Four Occurrences 1¾ in. (44 mm)
- Transducer Data

Evaluation Criteria	Transducer			NCHRP Report No. 350 Limit
	EDR-3	DTS		
		BF57H	CM54H	
Longitudinal OIV ft/s (m/s)	NA (No occupant contact)	NA (No occupant contact)	NA (No occupant contact)	≤ 16.4 ft/s (5.0)
Longitudinal ORA g's	NA (No occupant contact)	NA (No occupant contact)	NA (No occupant contact)	≤ 20 g's
Max. Vehicle ΔV ft/s (m/s)	16.44 (5.01)	16.40 (5.00)	16.36 (4.99)	≤ 16.4 ft/s (5.0)

Figure 40. Summary of Test Results and Sequential Photographs, Test No. BBC-3



0.000 sec



0.054 sec

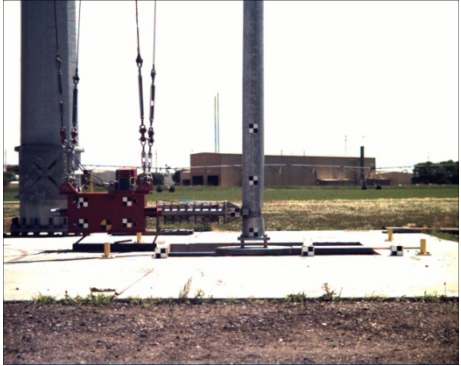

0.006 sec



0.068 sec



0.024 sec



0.320 sec



0.032 sec



0.492 sec

Figure 41. Additional Sequential Photographs, Test No. BBC-3

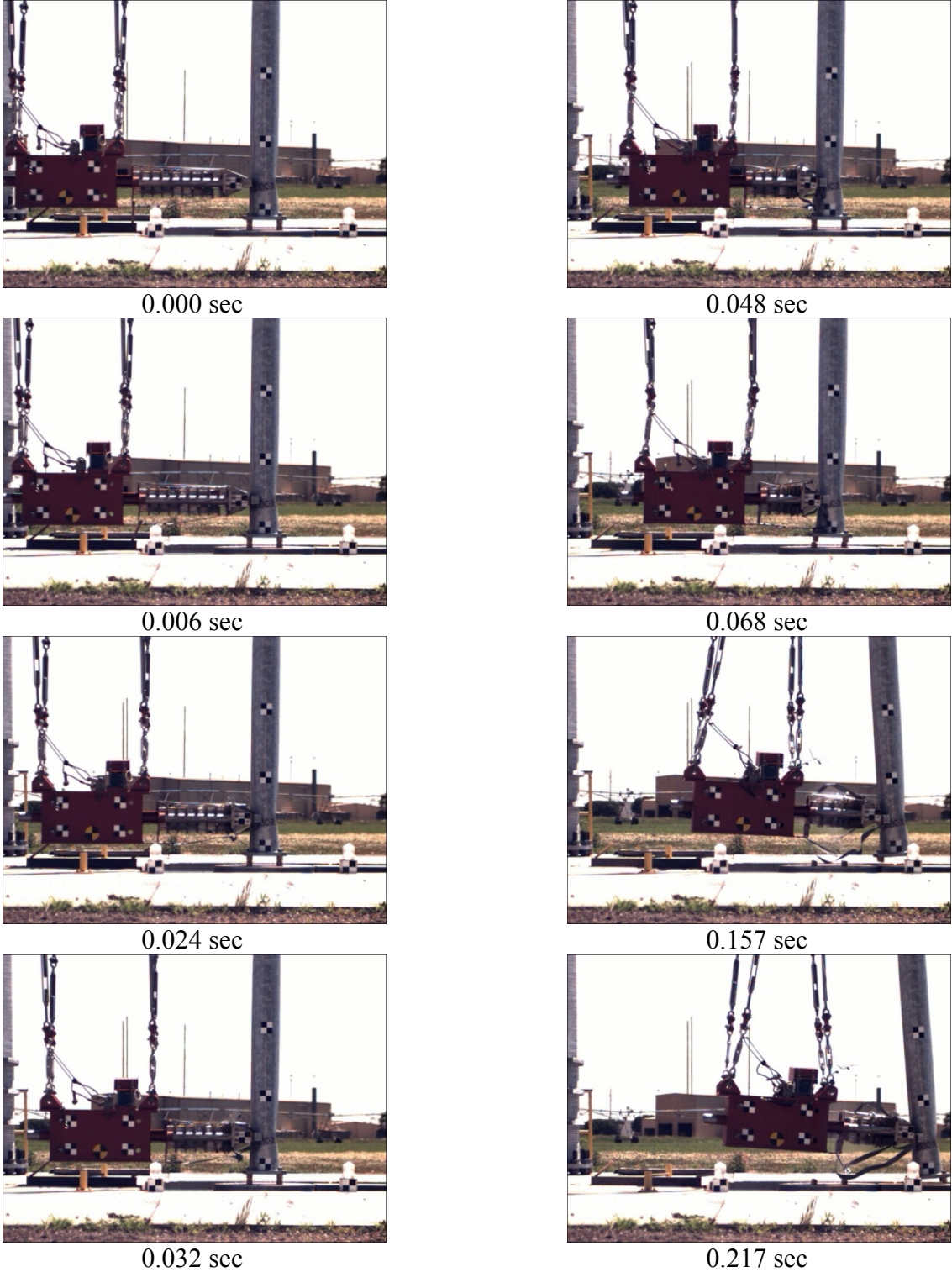

Figure 42. Additional Sequential Photographs, Test No. BBC-3



Figure 43. System Damage, Test No. BBC-3



Figure 44. System Damage, Test No. BBC-3

11 PENDULUM TEST NO. BBC-4

11.1 Test No. BBC-4

The 1,849-lb (839-kg) pendulum with crushable nose impacted the 53-ft (16.2-m) nominal height, steel luminaire pole with dual mast arms, simulated luminaire weights, and mounted in 1-in. (25-mm) diameter TRANSPO couplings at a speed of 23.3 mph (37.5 km/h). A summary of the test results and sequential photographs are shown in Figure 45. Additional sequential photographs are shown in Figures 46 and 47.

11.2 Weather Conditions

Test no. BBC-4 was conducted on June 15, 2010 at 1:45 pm. The weather conditions, as per the National Oceanic and Atmospheric Administration (station 04924/FET), were documented and are shown in Table 18.

Table 18. Weather Conditions, Test No. BBC-4

Temperature	75° F
Humidity	60%
Wind Speed	8 mph
Wind Direction	280° from True North
Sky Conditions	Scattered Clouds
Visibility	10 Statute Miles
Pavement Surface	Dry
Previous 3-Day Precipitation	3.60 in.
Previous 7-Day Precipitation	8.72 in.

11.3 Test Description

The pendulum impacted the pole system at the targeted impact height of 17½ in. (445 mm). A sequential description of the impact events is contained in Table 19.

Table 19. Sequential Description of Impact Events, Test No. BBC-4

Time (sec)	Event Description
0.000	Impact
0.008	Contact region of honeycomb element no. 1 was fully compressed.
0.016	Honeycomb element no. 2 was fully compressed.
0.024	Honeycomb element no. 3 was fully compressed.
0.039	Honeycomb element no. 4 was fully compressed.
0.048	Honeycomb element no. 5 was fully compressed.
0.059	Honeycomb element no. 6 was fully compressed.
0.060	Both front couplings fractured at the upper neck.
0.063	The left-rear coupling fractured at the upper neck, and the right-rear coupling fractured at both neck locations.
0.160	The pendulum nose lost contact with the pole.
0.300	The base of the pole contacted the ground.
0.730	The pendulum impacted the pole a second time on its upswing.
2.200	The top of the pole was captured by the rope tethers.

11.4 System Damage

Damage to the steel luminaire pole and TRANSPO couplings is shown in Figures 48 and 49. The steel pole was dented at the impact height. The base of the pole came to rest 28 ft (8.5 m) downstream from the initial attachment location with the top of the pole captured by the tether. The top of the pole and the two luminaire arms were bent due to the tether system catching the pole as it fell. All four couplings fractured. The right-rear coupling fractured in the lower neck location, resulting in a stub height of 3 in. (76 mm). The other three couplings only fractured at the upper neck location, resulting in stub heights of 6 in. (152 mm).

11.5 Occupant Risk

The occupant impact velocity (OIV) and maximum 0.010-sec occupant ridedown acceleration (ORA) were not calculated since the hypothetical occupant did not contact the dashboard within the time the pole was in contact with the vehicle. However, as described in Section 3.2, the pendulum’s change in longitudinal velocity throughout the impact event was recorded and compared against the NCHRP Report No. 350 OIV maximum allowable limit of 16.4 ft/s (5.0 m/s). The calculated change in velocity of 15.22 ft/s (4.64 m/s) was within the acceptable limit established by NCHRP Report No. 350, as shown in Table 20. The recorded data from the accelerometers are shown graphically in Appendix E.

Table 20. Occupant Risk Summary, Test No. BBC-4

Evaluation Criteria	Transducer			NCHRP Report No. 350 Limit
	EDR-3	DTS		
		BF57H	CM54H	
Longitudinal OIV ft/s (m/s)	NA (No occupant contact)	NA (No occupant contact)	NA (No occupant contact)	≤ 16.4 (5.0)
Longitudinal ORA g’s	NA (No occupant contact)	NA (No occupant contact)	NA (No occupant contact)	≤ 20
Maximum Vehicle ΔV ft/s (m/s)	14.99 (4.57)	15.22 (4.64)	15.22 (4.64)	≤ 16.4 (5.0)

11.6 Discussion

The analysis of the results for test no. BBC-4 showed that the 53-ft (16.2-m) nominal height, steel luminaire pole system with dual mast arms and mounted on TRANSPO Industries, Inc.’s Pole-Safe couplings broke away in a controlled and predictable manner. The high-speed video illustrated that the vehicle would pass underneath the pole before the luminaire system fell

to the ground. Therefore, the pole did not show a propensity to cause excessive deformations to the occupant compartment after it broke away. The change in velocity of the pendulum mass from initial impact until loss of contact with the test article was 15.22 ft/s (4.64 m/s), which falls below the 16.4 ft/s (5.0 m/s) maximum allowable limit established by NCHRP Report No. 350. Three of the couplings fractured at the upper neck location, resulting in stub heights of 6 in. (152 mm), which exceeded the 4-in. (100-mm) limit established by AASHTO's *Standard Specifications for Structural Supports for Highway Signs, Luminaires, and Traffic Signals, Fifth Edition* [2]. However, the TRANSPO couplings have been accepted by FHWA for use based on full-scale crash testing [9-10]. Therefore, test no. BBC-4 (test designation no. 3-60) with the TRANSPO Pole-Safe couplings passed the TL-3 safety performance criteria provided in NCHRP Report No. 350.



0.000 sec



0.048 sec



0.064 sec



0.124 sec



0.228 sec

- Test Agency MwRSF
- Test Facility Valmont-MwRSF/UNL Pendulum
- Test Number BBC-4
- Date 6/15/10
- NCHRP Report No. 350 Test Designation No. 3-60
- Test Article TRANSP0 1 in. (25 mm) Couplings, Steel Pole
- Nominal Luminaire Height 53 ft (16.2 m)
- Key Component – Tapered Steel Pole
 - Height 50 ft (15.3 m)
 - Bottom Diameter 11 in. (279 mm)
 - Thickness 10 gauge (3.42 mm)
- Key Component – Luminaire Mast Arm
 - Length 12 ft (3.7 m)
 - Mounting Height 49 ft – 7 in. (15.1 m)
- Key Component – Coupling
 - Type TRANSP0 Pole-Safe Double-Neck
 - Diameter 1 in. (25 mm)
- Total Installation Mass 923 lb (419 kg)
 - Pole 602 lb (273 kg)
 - Arms 321 lb (146 kg)
- Surrogate Vehicle Pendulum
 - Mass 1,849 lb (839 kg)
 - Impact Head Crushable Nose

- Impact Conditions
 - Speed 23.3 mph (37.5 km/h)
 - Angle 0 deg
 - Impact Height 17½ in. (445 mm)
- Test Article Damage Minimal
- Stub Heights
 - Three Occurrences 6 in. (152 mm)
 - One Occurrence 3 in. (76 mm)
- Transducer Data

Evaluation Criteria	Transducer			NCHRP Report No. 350 Limit
	EDR-3	DTS		
		BF57H	CM54H	
Longitudinal OIV ft/s (m/s)	NA (No occupant contact)	NA (No occupant contact)	NA (No occupant contact)	≤ 16.4 ft/s (5.0)
Longitudinal ORA g's	NA (No occupant contact)	NA (No occupant contact)	NA (No occupant contact)	≤ 20 g's
Max. Vehicle ΔV ft/s (m/s)	14.99 (4.57)	15.22 (4.64)	15.22 (4.64)	≤ 16.4 ft/s (5.0)

Figure 45. Summary of Test Results and Sequential Photographs, Test No. BBC-4



0.000 sec



0.208 sec



0.040 sec



0.300 sec



0.064 sec



0.420 sec



0.122 sec



0.432 sec

Figure 46. Additional Sequential Photographs, Test No. BBC-4



0.000 sec



0.075 sec



0.016sec



0.101 sec



0.039 sec



0.157 sec



0.058 sec



0.208 sec

Figure 47. Additional Sequential Photographs, Test No. BBC-4



Figure 48. System Damage, Test No. BBC-4



Figure 49. System Damage, Test No. BBC-4

12 PENDULUM TEST NO. BBC-5

12.1 Test No. BBC-5

The 1,849-lb (839-kg) pendulum with crushable nose impacted the 30-ft (9.1-m) nominal height, aluminum luminaire pole with single mast arm, simulated luminaire weights, and mounted on brass breakaway couplings (Version 2) at a speed of 21.8 mph (35.1 km/h). A summary of the test results and sequential photographs are shown in Figure 50. Additional sequential photographs are shown in Figures 51 and 52.

12.2 Weather Conditions

Test no. BBC-5 was conducted on June 15, 2010 at 3:30 pm. The weather conditions, as per the National Oceanic and Atmospheric Administration (station 04924/FET), were documented and are shown in Table 21.

Table 21. Weather Conditions, Test No. BBC-5

Temperature	77° F
Humidity	52%
Wind Speed	11 mph
Wind Direction	270° from True North
Sky Conditions	Scattered Clouds
Visibility	10 Statute Miles
Pavement Surface	Dry
Previous 3-Day Precipitation	3.60 in.
Previous 7-Day Precipitation	8.72 in.

12.3 Test Description

The pendulum impacted the pole system at the targeted impact height of 17½ in. (445 mm). A sequential description of the impact events is contained in Table 22.

Table 22. Sequential Description of Impact Events, Test No. BBC-5

Time (sec)	Event Description
0.000	Impact
0.008	Contact region of honeycomb element no. 1 was fully compressed.
0.014	Honeycomb element no. 2 was fully compressed.
0.025	Honeycomb element no. 3 was fully compressed.
0.037	Honeycomb element no. 4 was fully compressed.
0.044	Both front couplings fractured.
0.050	Both rear couplings fractured in the middle notch region.
0.144	The pendulum lost contact with the pole.
0.759	The pendulum impacted the pole a second time on its upswing, while the rope tethers caught the top of the pole.
2.552	The luminaire arm twisted off the tethers.
3.828	The pole fell to the ground.

12.4 System Damage

Damage to the luminaire pole and brass couplings (Version 2) is shown in Figure 53. The aluminum pole was slightly dented at the impact location. The base of the pole came to rest 32 ft (9.8. m) downstream from the initial attachment location with the top of the pole lying near the simulated rigid foundation. All four brass couplings fractured through the center notch, resulting in stub heights of 1¾ in. (44 mm).

12.5 Occupant Risk

The occupant impact velocity (OIV) and maximum 0.010-sec occupant ridedown acceleration (ORA) were not calculated since the hypothetical occupant did not contact the dashboard within the time the pole was in contact with the vehicle. However, as described in

Section 3.2, the pendulum’s change in longitudinal velocity throughout the impact event was recorded and compared against the NCHRP Report No. 350 OIV maximum allowable limit of 16.4 ft/s (5.0 m/s). The calculated change in velocity of 10.24 ft/s (3.12 m/s) was within the acceptable limit, as shown in Table 23. The recorded accelerometer data are shown graphically in Appendix F.

Table 23. Occupant Risk Summary, Test No. BBC-5

Evaluation Criteria	Transducer			NCHRP Report No. 350 Limit
	EDR-3	DTS		
		BF57H	CM54H	
Longitudinal OIV ft/s (m/s)	NA (No occupant contact)	NA (No occupant contact)	NA (No occupant contact)	≤ 16.4 (5.0)
Longitudinal ORA g’s	NA (No occupant contact)	NA (No occupant contact)	NA (No occupant contact)	≤ 20
Maximum Vehicle ΔV ft/s (m/s)	10.59 (3.23)	10.24 (3.12)	10.24 (3.12)	≤ 16.4 (5.0)

12.6 Discussion

The analysis of the results for test no. BBC-5 showed that the 30-ft (9.1-m) nominal height, aluminum luminaire pole system with a single mast arm and mounted on the brass couplings (Version 2) broke away in a controlled and predictable manner. The high-speed video illustrated that the vehicle would pass underneath the pole before the luminaire system fell to the ground. Therefore, the pole did not show a propensity to cause excessive deformations to the occupant compartment after it broke away. The change in velocity of the pendulum throughout the impact event was 10.24 ft/s (3.12 m/s), falling under the NCHRP Report No. 350 maximum allowable limit of 16.4 ft/s (5.0 m/s). All four couplings fractured through the notch, thus leaving

stub heights of 1¼ in. (44 mm), which falls below the 4-in. (100-mm) limit. Therefore, test no. BBC-5 (test designation no. 3-60) with brass breakaway couplings (Version 2) passed the TL-3 safety performance criteria provided in NCHRP Report No. 350.



0.000 sec



0.016 sec



0.054 sec



0.130 sec



0.164 sec

- Test Agency MwRSF
- Test Facility Valmont-MwRSF/UNL Pendulum
- Test Number BBC-5
- Date 6/15/10
- NCHRP Report No. 350 Test Designation No. 3-60
- Test Article.. Brass Couplings (Version 2) and Aluminum Pole
- Nominal Luminaire Height 30 ft (9.1 m)
- Key Component – Tapered Aluminum Pole
 - Height 27 ft – 8 in. (8.4 m)
 - Bottom Diameter 8 in. (203 mm)
 - Thickness ¼ in. (6.4 mm)
- Key Component – Luminaire Mast Arm
 - Length 68 in. (1,727 mm)
 - Mounting Height 27 ft – 8 in. (8.4 m)
- Key Component – Couplings
 - Material ASTM B16 Brass
 - Shape Hexagon
 - Size 1½ in. (38 mm)
 - Length 3½ in. (89 mm)
- Total Installation Mass 259 lb (118 kg)
 - Pole 169 lb (77 kg)
 - Arm 90 lb (41 kg)
- Surrogate Vehicle Pendulum
 - Mass 1,849 lb (839 kg)
 - Impact Head Crushable Nose

- Impact Conditions
 - Speed 21.8 mph (35.1 km/h)
 - Angle 0 deg
 - Impact Height 17½ in. (445 mm)
- Test Article Damage Moderate
- Stub Heights
 - Four Occurrences 1¼ in. (44 mm)
- Transducer Data

Evaluation Criteria	Transducer			NCHRP Report No. 350 Limit
	EDR-3	DTS		
		BF57H	CM54H	
Longitudinal OIV ft/s (m/s)	NA (No occupant contact)	NA (No occupant contact)	NA (No occupant contact)	≤ 16.4 ft/s (5.0)
Longitudinal ORA g's	NA (No occupant contact)	NA (No occupant contact)	NA (No occupant contact)	≤ 20 g's
Max. Vehicle ΔV ft/s (m/s)	10.59 (3.23)	10.24 (3.12)	10.24 (3.12)	≤ 16.4 ft/s (5.0)

Figure 50. Summary of Test Results and Sequential Photographs, Test No. BBC-5



0.000 sec



0.130 sec



0.012 sec



0.204 sec



0.026 sec



0.264 sec



0.044 sec



0.290 sec

Figure 51. Additional Sequential Photographs, Test No. BBC-5



0.000 sec



0.053 sec



0.011sec



0.084 sec



0.025 sec



0.120 sec



0.045 sec



0.151 sec

Figure 52. Additional Sequential Photographs, Test No. BBC-5



Figure 53. System Damage, Test No. BBC-5

13 SUMMARY OF ROUND 2 TESTING

During the Round 2 testing program, the modified breakaway brass coupling (Version 2) was evaluated using the T1-3 safety performance criteria provided in NCHRP Report No. 350 and then compared to TRANSPO's 1-in. (25-mm) diameter Pole-Safe, Double-Neck couplings. A summary of the test evaluations is provided in Table 24.

In test no. BBC-3, the Version 2 brass couplings supported a 53-ft (16.2-m) nominal height, 10-gauge (3.42-mm) thick, steel luminaire pole with dual mast arms. During this test, all four of the brass couplings fractured, and the pole broke away in a controlled and predicted manner. The calculated change in velocity from several accelerometers was at the NCHRP Report No. 350 limit of 16.4 ft/s (5.0 m/s), ranging from 16.36 to 16.44 ft/s (4.99 to 5.01 m/s). As a result, the test results were determined to marginally pass the TL-3 safety performance criteria found in NCHRP Report No. 350. These results were then used to extrapolate the change in velocity for a high-speed test (test designation no. 3-61) using the published extrapolation equations. These calculations resulted in a change in velocity of 18.49 ft/s (5.64 m/s), which exceeds the maximum allowable limit. The extrapolation equation calculations are detailed in Chapter 18.

In test no. BBC-4, the same heavy steel pole was mounted to a set of previously-tested and FHWA-accepted couplings, TRANSPO's Pole-Safe, Double-Neck couplings. Upon impact, all four of the couplings fractured, resulting in stub heights ranging between 3 and 6 in. (76 and 152 mm). From an analysis of the test data, a change in velocity of 15.22 ft/s (4.64 m/s) was obtained, thus satisfying the maximum allowable limit. When this test result was utilized in the extrapolation equation, the high-speed change in velocity was found to be 18.19 ft/s (5.54 m/s), which exceeded the limit of 16.4 ft/s (5.0 m/s). These calculations are detailed in Chapter 18.

Two findings were obtained from the results of test nos. BBC-3 and BBC-4. First, the Version 2 breakaway brass couplings showed significant improvement for reducing the impact loads and velocity changes. However, the brass coupling did not break away as quickly as the TRANSPO coupling. As a result, the brass couplings were again modified for another round of testing. Second, the heavy, steel luminaire pole selected by the ILDOT had too much rotational inertia to satisfy the change in velocity requirement when using the high-speed extrapolation procedure. Even the TRANSPO Pole-Safe coupling, a tested and FHWA-accepted coupling, did not satisfy the change in velocity requirements for a high-speed test when using the extrapolation equation. Therefore, a different luminaire pole would be necessary to establish the upper bound of acceptable configurations for use with the brass couplings. Both the modifications to the brass coupling and the new pole selections are detailed in Chapter 14.

In test no. BBC-5, the Version 2 brass couplings were used to support a 30-ft (9.1-m) nominal height, ¼-in. (6.4-mm) thick, aluminum luminaire pole. The pole broke away in a controlled, predictable manner. An analysis of the test results revealed a change in velocity of 10.24 ft/s (3.12 m/s), satisfying the NCHRP Report No. 350 maximum allowable limit of 16.4 ft/s (5.0 m/s). Further, the extrapolation equation was used to calculate a change in longitudinal velocity of 7.61 ft/s (2.32 m/s). Therefore, the test results satisfied the safety performance requirements, and the tested system can be identified as the smallest and weakest of the luminaire poles for which the brass couplings are appropriate. In other words, aluminum poles with a thickness of at least ¼ in. (6.4 mm) and a base diameter of at least 8 in. (203 mm) would be approved for use with the breakaway brass couplings. The brass couplings used in test no. BBC-5 were not the final version of the couplings. However, the difference between Version 2 and Version 3 (as described later) only improves its ability to breakaway by lowering the fracture loads. Thus, the Version 3 brass couplings would perform just as well, if not better, than the

version 2 couplings, and the system evaluated in test no. BBC-5 would still satisfy the T1-3 safety performance criteria provided in NCHRP Report No. 350.

Table 24. Summary of Safety Performance Evaluation Results, Round 2 Testing Program

NCHRP Report No. 350 Criteria		Test No. BBC-3	Test No. BBC-4	Test No. BBC-5	
Structural Adequacy	C. The test article should readily activate in a predictable manner by breaking away, fracturing or yielding.	S	S	S	
Occupant Risk	E. Detached elements, fragments or other debris from the test article should not penetrate or show potential for penetrating the occupant compartment or present an undue hazard to other traffic, pedestrians, or personnel in a work zone. Deformations of, or intrusions into, the occupant compartment that could cause serious injury should not be permitted. See discussion in Section 5.3 and Appendix E of NCHRP Report No. 350.	S	S	S	
	G. The vehicle should remain upright during and after collision although moderate roll, pitch, and yaw are acceptable.	NA	NA	NA	
	J. Occupant Impact Velocity (OIV) (see Appendix A, Section A5.3 of NCHRP Report No. 350 for calculation procedure) should satisfy the following:	S	S	S	
	Occupant Impact Velocity Limits				
	Component				Preferred
	Longitudinal	9.8 ft/s (3.0 m/s)	16.4 ft/s (5.0 m/s)		
K. The Occupant Ridedown Acceleration (ORA) (see Appendix A, Section A5.3 of NCHRP Report No. 350 for calculation procedure) should satisfy the following:	NA	NA	NA		
Occupant Ridedown Acceleration Limits					
Component				Preferred	Maximum
	Longitudinal and Lateral	15 g's	20 g's		
Vehicle Trajectory	L. After collision it is preferable that the vehicle's trajectory not intrude into adjacent traffic lanes.	NA	NA	NA	
	O. Vehicle trajectory behind the test article is acceptable	S	S	S	
AASHTO Fifth Edition Additional Criteria					
Structural Adequacy	Substantial remains of breakaway supports shall not project more than 4 in. (100 mm) above a line between straddling wheels of a vehicle on 60 in. (1500 mm) centers. The line connects any point on the ground surface one side of the support to a point on the ground surface on the other side, and it is aligned radially or perpendicularly to the centerline of the roadway.	S	S	S	
	The maximum mass of combined luminaire support and fixtures attached to breakaway supports shall be limited to 992 lb (450 kg). Any increase in these limits are to be based on full-scale crash testing and an investigation on the range of the roof crush characteristics that go beyond the recommended testing procedures of NCHRP Report No. 350.	S	S	S	

S- Satisfactory U-Unsatisfactory NA-Not Applicable

100

14 TEST INSTALLATION DETAILS – ROUND 3

14.1 Breakaway Brass Couplings (Version 3), Test Nos. BBC-6 and BBC-7

Following a review and analysis of the results from test nos. BBC-3 and BBC-4, as discussed in Chapter 13, it was evident that the Version 2 breakaway brass couplings did not fracture quickly enough and/or resisted too high of an impact load. Therefore, further research and component testing was undertaken, and the Version 3 brass coupling was developed. The top segment of the Version 3 brass coupling was extended from 1¾ in. (44 mm) to 3½ in. (89 mm), resulting in an overall height of 5¼ in. (133 mm). The notch size and its distance to the bottom of the coupling remained the same. The longer top segment served to provide a longer moment arm between the luminaire pole's base plate and the notch. Thus, under lateral loading from a vehicle impact, higher bending forces would be imparted to the notched cross section of the coupling, causing fracture and lower impact loads. Version 3 of the brass couplings is detailed in Figure 54 and shown in Figure 55.

14.2 Luminaire Poles

After analyzing the results from test nos. BBC-3 and BBC-4, the heavy, steel luminaire pole was deemed to have too much mass and rotational inertia to satisfy the change in velocity limits of NCHRP Report No. 350, specifically for test designation no. 3-61. When considering the parameters in the high-speed extrapolation equation, as detailed in Chapter 18, the inertial contribution of this heavy steel luminaire pole to the change in velocity made it difficult to obtain a successful high-speed test result. Therefore, a shorter and lighter steel luminaire pole was selected for further testing with the brass coupling.

However, ILDOT personnel still desired to use the brass couplings when taller luminaire poles were warranted. Traditionally, the height and weight of an as-tested luminaire pole system became the upper bounds for acceptable configurations. Thus, a taller pole was needed for

testing to gain acceptance of the brass couplings in such instances. Although using steel poles appeared to be limited to only shorter installations, opting to use an aluminum pole would result in a reduction in both weight and rotational inertia when compared to similar-sized steel poles. With these reductions, a tall aluminum pole would likely satisfy the safety performance criteria and was selected for testing.

For test nos. BBC-6 and BBC-7, ropes were used to tether the top of the pole to the pendulum support structure. The ropes allowed the top of the pole to fall about 10 ft (3 m) from its original position before it was caught. Thus, the tether did not inhibit the freefall/rotation of the pole until after the impact event.

14.2.1 Steel Luminaire Pole, Test No. BBC-6

The selected steel luminaire pole had a 45-ft (13.7-m) nominal mounting height, as shown in Figure 56. The pole was a 7-gauge (4.55-mm thick), 40-ft (12.2-m) long shaft with top and bottom diameters of 4½ in. (114 mm) and 10 in. (254 mm), respectively. The base plate was a 1¼ in. (32 mm) thick by 14 in. (356 mm) square. The bolt circle was 13½ in. (343 mm) in diameter. Dual 15-ft (4.6-m) truss arms were attached to the top of the pole. The pole weighed 571 lb (259 kg), while the arms and simulated luminaires weighed 329 lb (149 kg). The total weight of the luminaire pole system was 900 lb (409 kg).

14.2.2 Aluminum Luminaire Pole, Test No. BBC-7

The selected aluminum luminaire pole had a 55-ft (16.8-m) nominal mounting height, as shown in Figures 57 and 58. The pole shaft was 50-ft (15.2-m) long, ⁵/₁₆-in. (8-mm) thick, and had top and bottom diameters of 6 in. (152 mm) and 10 in. (254 mm), respectively. The base plate was a 1¼ in. (32 mm) thick by 14 in. (356 mm) square. The bolt circle was 15 in. (381 mm) in diameter. Dual 15-ft (4.6-m) truss arms were attached to top of the pole. The pole weighed

536 lb (243 kg), while the arms with simulated luminaires weighed 219 lb (99 kg). The total weight of the luminaire pole system was 755 lb (343 kg).

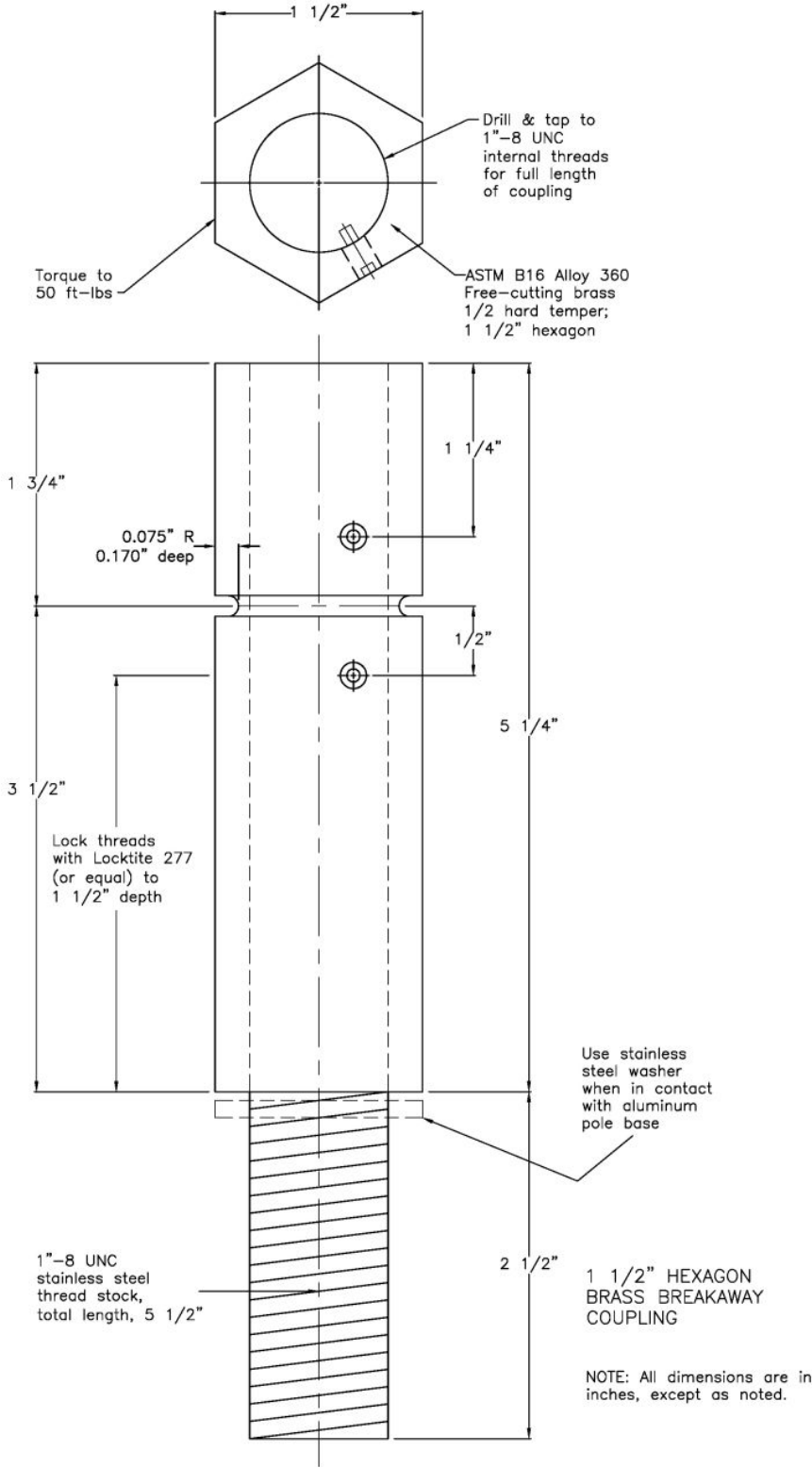

Figure 54. Version 3 Brass Coupling Details, Test Nos. BBC-6 and BBC-7

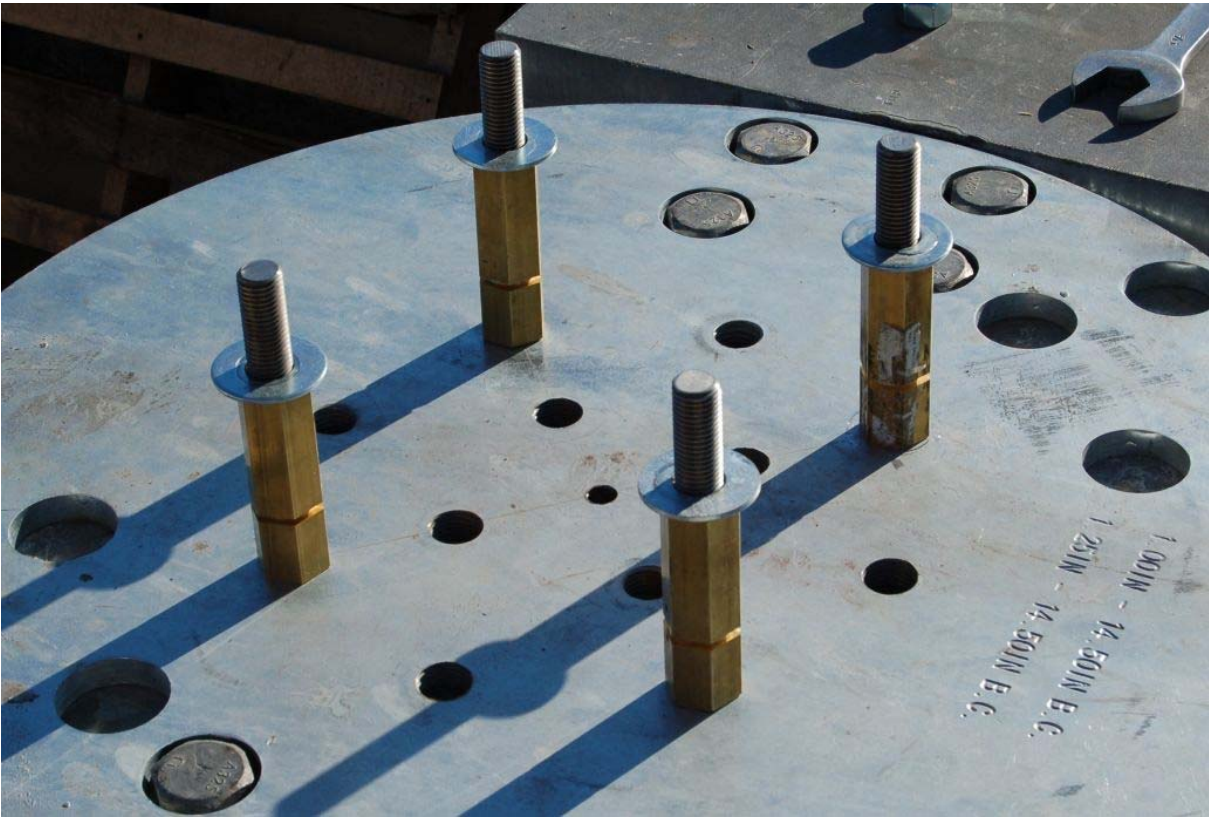

Figure 55. Version 3 Brass Couplings, Test Nos. BBC-6 and BBC-7

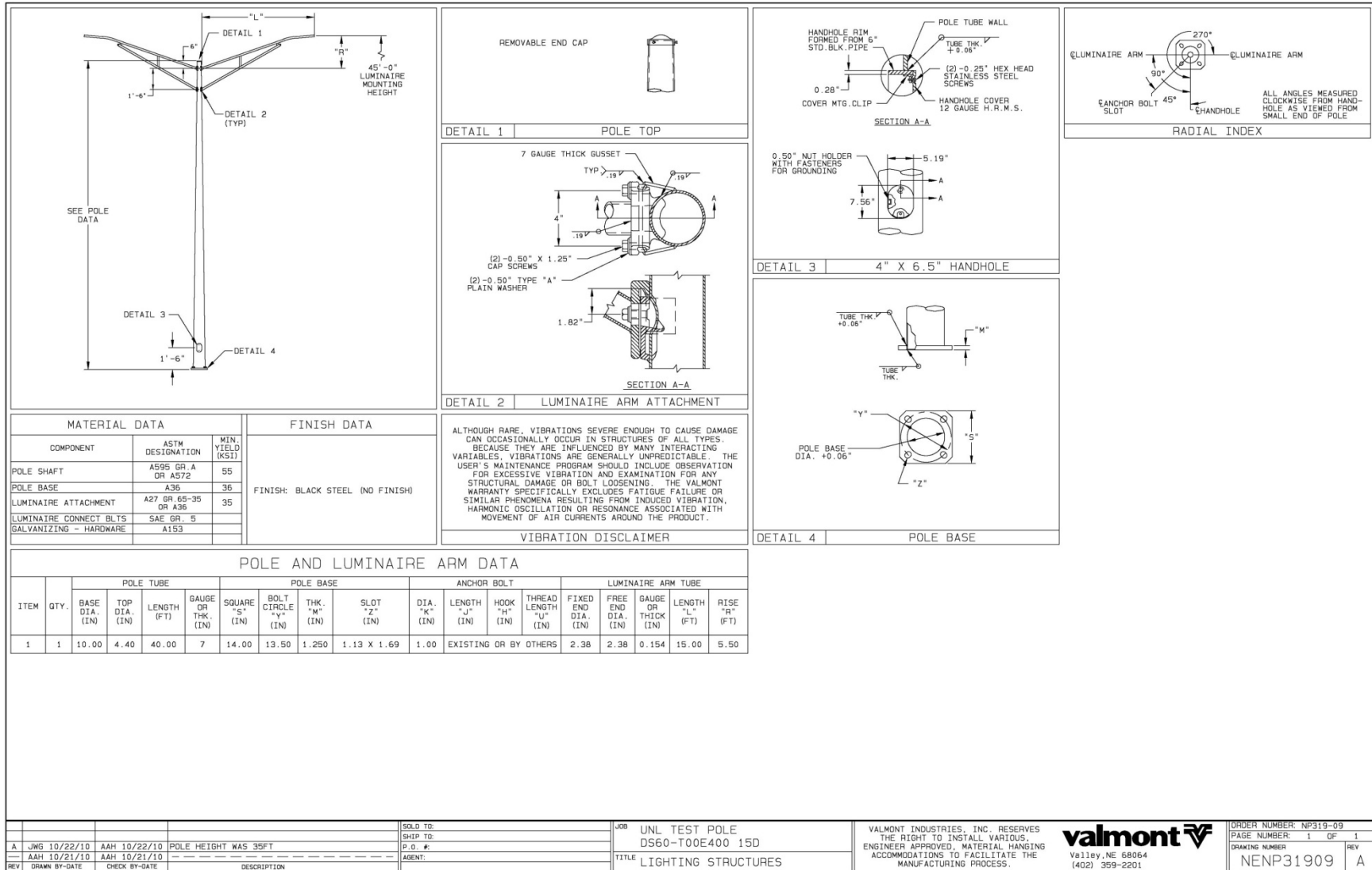
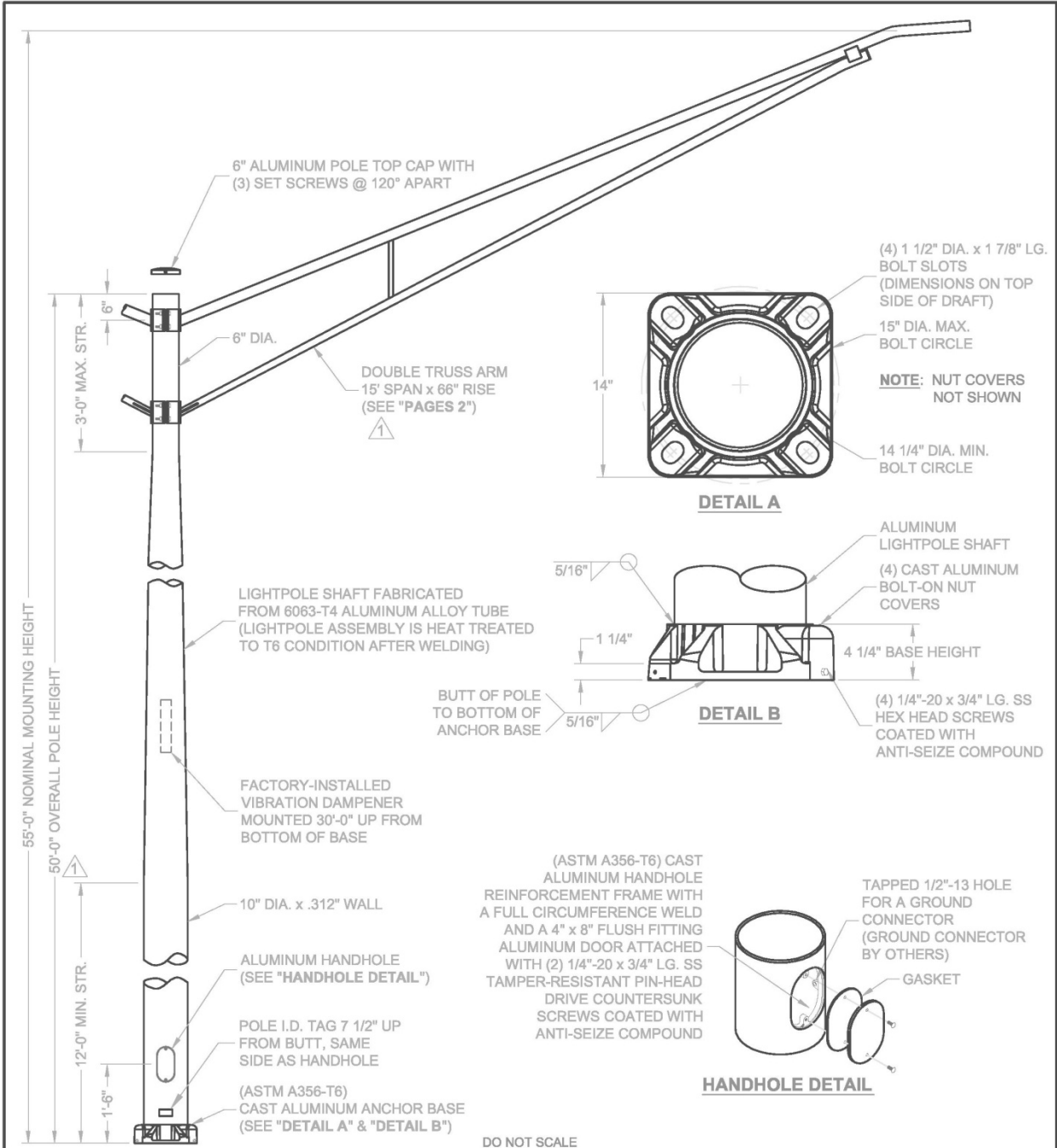

Figure 56. Steel Luminaire Pole, Test No. BBC-6



<p>Valmont Industries, Inc. Structures Division 20805 Eaton Ave Farmington, Minnesota 55024-7932 Phone: (651) 463-8990 (800) 899-7577 Fax: (651) 463-3349</p>	<p>TITLE: S ANCHOR BASE LIGHTPOLES</p> <p>MODEL NO.:</p> <p>MATERIAL: ALUMINUM ALLOY</p> <p>FINISH: 100 GRIT SATIN POLISH</p> <p>PROJECT: STANDARD IDOT SUBMITTALS</p> <p>SOLD TO:</p> <p>SHIP TO:</p> <p>P.O. NO.:</p> <p>REP: LIGHTING SOLUTIONS OF ILLINOIS</p>	<p>QTY:</p> <p>DWN BY: PTP</p> <p>CHK'D BY:</p> <p>APPR BY:</p> <p>DATE: 10-20-10</p> <p>DWG NO: DR6173</p> <p>PAGE: 1/2</p>
	<p>LUMINAIRE POLE</p> <p>WITH RESPECT TO ELECTRICAL HAZARDS ONLY NOT FOR MECHANICAL STRENGTH OR WIND LOADING 30 UM -- SUITABLE FOR WET LOCATIONS</p> <p>**CONFIDENTIAL**</p> <p>The information contained in this drawing is privileged and confidential, and may be protected from disclosure. Please be aware that any use or dissemination of this drawing may be subject to legal restriction or sanction.</p>	<p>10-21-10 CHG'D TRUSS ARM RISE & POLE HEIGHT</p> <p>REV DATE REVISION DESCRIPTION BY</p>

Figure 57. Aluminum Luminaire Pole Details, Test No. BBC-7

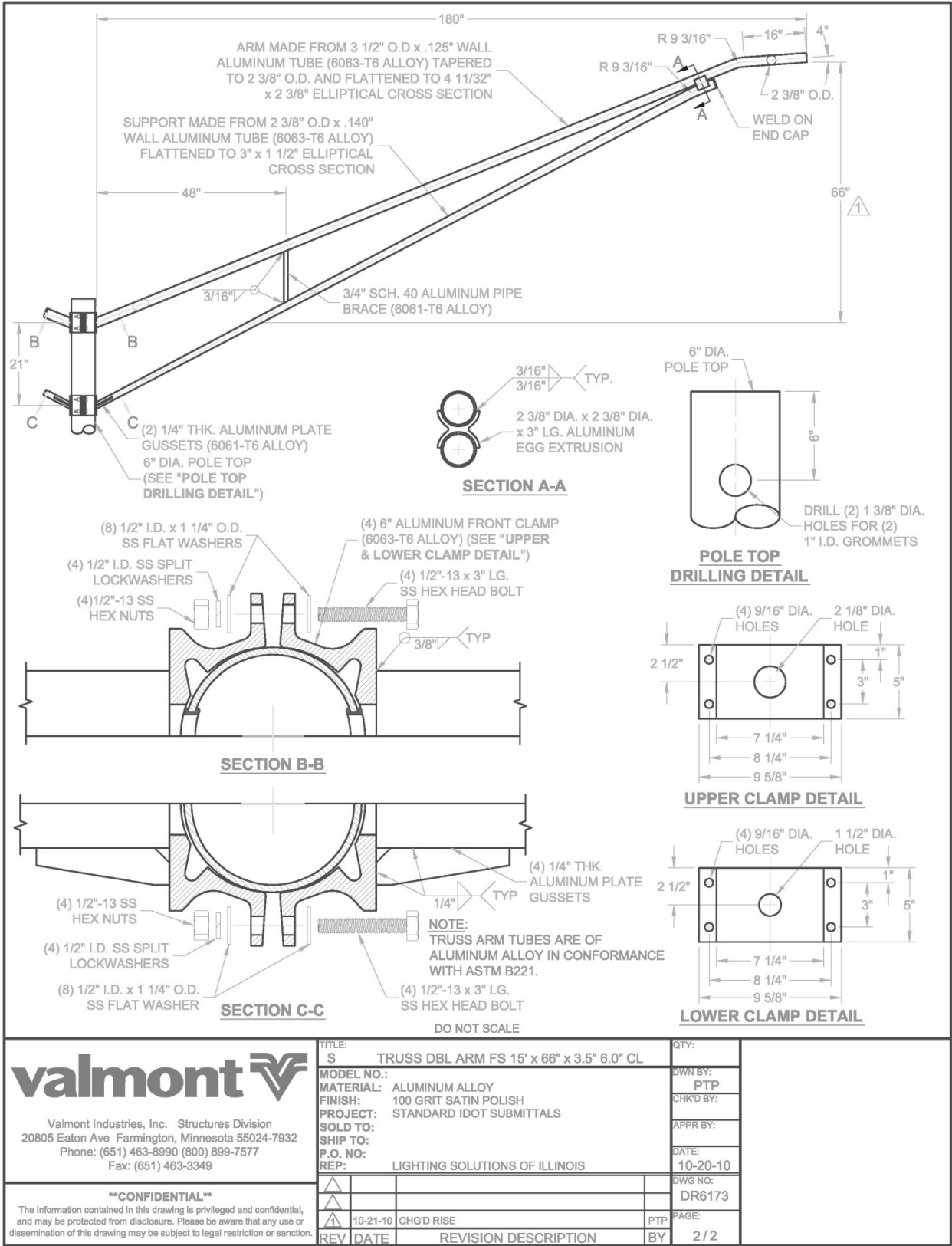

Figure 58. Aluminum Luminaire Arm Details, Test No. BBC-7



Figure 59. Assembled Test Installation, Test No. BBC-6

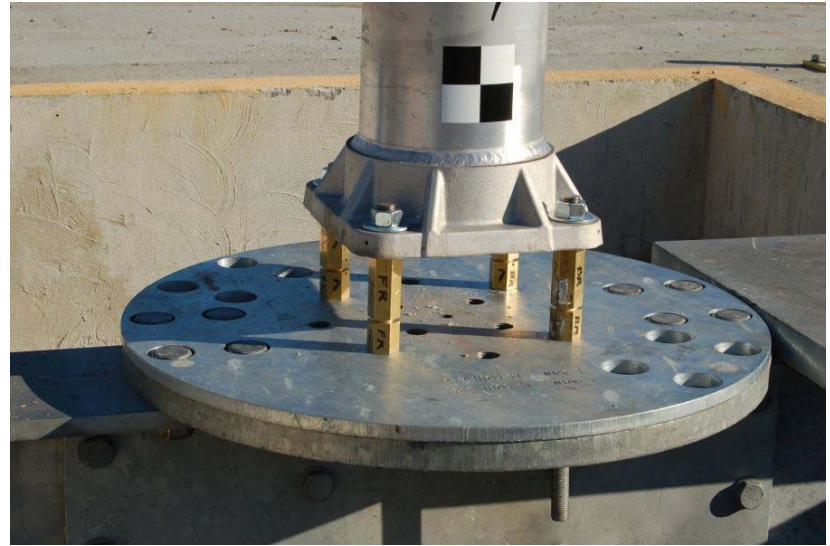

Figure 60. Assembled Test Installation, Test No. BBC-7

15 PENDULUM TEST NO. BBC-6

15.1 Test No. BBC-6

The 1,882-lb (854-kg) pendulum with crushable nose impacted the 45-ft (13.7-m) nominal height, steel luminaire pole with dual mast arms, simulated luminaire weights, and mounted on breakaway brass couplings (Version 3) at a speed of 22.2 mph (35.8 km/h). A summary of the test results and sequential photographs are shown in Figure 61. Additional sequential photographs are shown in Figures 62 and 63.

15.2 Weather Conditions

Test no. BBC-6 was conducted on December 1, 2010 at 1:00 pm. The weather conditions, as per the National Oceanic and Atmospheric Administration (station 04924/FET), were documented and are shown in Table 25.

Table 25. Weather Conditions, Test No. BBC-6

Temperature	28° F
Humidity	56%
Wind Speed	10 mph
Wind Direction	280° from True North
Sky Conditions	Clear
Visibility	10 Statute Miles
Pavement Surface	Dry
Previous 3-Day Precipitation	0.0 in.
Previous 7-Day Precipitation	0.0 in.

15.3 Test Description

The pendulum impacted the pole system at the targeted impact height of 17½ in. (445 mm). A sequential description of the impact events is contained in Table 26.

Table 26. Sequential Description of Impact Events, Test No. BBC-6

Time (sec)	Event Description
0.000	Impact
0.010	Contact region of honeycomb element no. 1 was fully compressed.
0.017	Honeycomb element no. 2 was fully compressed.
0.028	Honeycomb element no. 3 was fully compressed.
0.038	Honeycomb element no. 4 was fully compressed.
0.044	Honeycomb element no. 5 was fully compressed.
0.048	Honeycomb element no. 6 was fully compressed.
0.056	The two front couplings fractured.
0.057	Honeycomb element no. 7 was fully compressed.
0.061	The two back couplings fractured.
0.190	The base of the pole contacted the ground as the pole rotated away from the impacting pendulum.
0.240	The pendulum lost contact with the pole.
0.622	The pendulum impacted the pole for a second time on its upswing.
1.400	The top of the pole was caught by the tether ropes.

15.4 System Damage

Damage to the luminaire pole and brass couplings is shown in Figures 64 and 65. The luminaire arms were bent slightly forward from when the tethers caught the pole as it fell. The base of the pole came to rest 20 ft (6.1 m) downstream from the initial attachment location with the top of the pole captured by the tether system. All four brass couplings fractured through the notch, thus, leaving stub heights of 1³/₄ in. (44 mm).

15.5 Occupant Risk

The occupant impact velocity (OIV) and maximum 0.010-sec occupant ridedown acceleration (ORA) were not calculated since the hypothetical occupant did not contact the dashboard within the time that the pole was in contact with the vehicle. However, as described in Section 3.2, the pendulum's change in velocity throughout the impact event was recorded and compared against the NCHRP Report No. 350 OIV maximum allowable limit of 16.4 ft/s (5.0 m/s). The calculated longitudinal change in velocity satisfied the NCHRP Report No. 350 limit using each of the accelerometer transducers, as shown in Table 27. The recorded data from the accelerometers are shown graphically in Appendix G.

Table 27. Occupant Risk Summary, Test No. BBC-6

Evaluation Criteria	Transducer			NCHRP Report No. 350 Limit
	EDR-3	DTS		
		BF57H	CM54H	
Longitudinal OIV ft/s (m/s)	NA (No occupant contact)	NA (No occupant contact)	NA (No occupant contact)	≤ 16.4 (5.0)
Longitudinal ORA g's	NA (No occupant contact)	NA (No occupant contact)	NA (No occupant contact)	≤ 20
Maximum Vehicle ΔV ft/s (m/s)	13.39 (4.08)	12.96 (3.95)	13.25 (4.04)	≤ 16.4 (5.0)

15.6 Discussion

The analysis of the results for test no. BBC-6 showed that the 45-ft (13.7-m) nominal height, steel luminaire pole with dual mast arms and mounted on the Version 3 brass couplings broke away in a controlled and predictable manner. The high-speed video illustrated that the vehicle would pass underneath the luminaire pole before it fell to the ground. Therefore, the pole

did not show a propensity to cause excessive deformations to the occupant compartment after it broke away. The change in velocity of the pendulum mass from initial impact until loss of contact with the test article was 13.25 ft/s (4.04 m/s), which satisfied the NCHRP Report No. 350 maximum allowable limit of 16.4 ft/s (5.0 m/s). Therefore, test no. BBC-6 (test designation no. 3-60) with Version 3 brass couplings passed the TL-3 safety performance criteria provided in NCHRP Report No. 350.

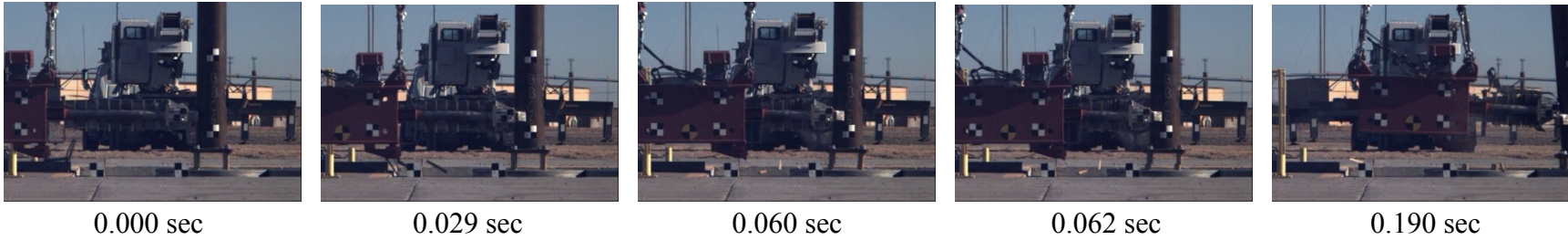

- Test Agency MwRSF
- Test Facility..... Valmont-MwRSF/UNL Pendulum
- Test Number..... BBC-6
- Date 12/1/10
- NCHRP Report No. 350 Test Designation No..... 3-60
- Test Article..... Brass Couplings (Version 3) and Steel Pole
- Nominal Height..... 45 ft (13.7 m)
- Key Component – Tapered Steel Pole
 - Height 40 ft (12.2 m)
 - Bottom Diameter 10 in. (254 mm)
 - Thickness 7 gauge (4.55 mm)
- Key Component – Luminaire Mast Arms
 - Length..... 15 ft (4.6 m)
 - Mounting Height..... 39 ft - 6 in. (12.0 m)
- Key Component – Brass Couplings (Version 3)
 - Material..... ASTM B16 Brass
 - Shape Hexagon
 - Width 1½ in. (38.1 mm)
 - Length..... 5¼ in. (133 mm)
- Total Installation Mass 900 lb (409 kg)
 - Pole..... 571 lb (259 kg)
 - Arms 329 lb (149 kg)
- Surrogate Vehicle..... Pendulum
 - Mass..... 1,882 lb (854 kg)
 - Impact Head..... Crushable Nose

- Impact Conditions
 - Speed 22.2 mph (35.8 km/h)
 - Angle 0 deg
 - Impact Height..... 17½ in. (445 mm)
- Stub Heights
 - Four Occurrences 1¾ in. (44 mm)
- Test Article Damage Minimal
- Transducer Data

Evaluation Criteria	Transducer			NCHRP Report No. 350 Limit
	EDR-3	DTS		
		BF57H	CM54H	
Longitudinal OIV ft/s (m/s)	NA (No occupant contact)	NA (No occupant contact)	NA (No occupant contact)	≤ 16.4 ft/s (5.0)
Longitudinal ORA g's	NA (No occupant contact)	NA (No occupant contact)	NA (No occupant contact)	≤ 20 g's
Max. Vehicle ΔV ft/s (m/s)	13.39 (4.08)	12.96 (3.95)	13.25 (4.04)	≤ 16.4 ft/s (5.0)

Figure 61. Summary of Test Results and Sequential Photographs, Test No. BBC-6



0.000 sec



0.240 sec



0.060 sec



0.380 sec



0.102 sec



0.460 sec



0.178 sec



0.622 sec

Figure 62. Additional Sequential Photographs, Test No. BBC-6
116



0.000 sec



0.534 sec



0.067 sec



0.801 sec



0.133sec



1.134 sec



0.200 sec



1.267 sec

Figure 63. Additional Sequential Photographs, Test No. BBC-6



Figure 64. System Damage, Test No. BBC-6



Figure 65. System Damage, Test No. BBC-6

16 PENDULUM TEST NO. BBC-7

16.1 Test No. BBC-7

The 1,882-lb (854-kg) pendulum with crushable nose impacted the 55-ft (16.8-m) nominal height, aluminum luminaire pole with dual mast arms, simulated luminaire weights, and mounted on breakaway brass couplings (Version 3) at a speed of 21.8 mph (35.1 km/h). A summary of the test results and sequential photographs are shown in Figure 66. Additional sequential photographs are shown in Figures 67 and 68.

16.2 Weather Conditions

Test no. BBC-7 was conducted on December 1, 2010 at 2:30 pm. The weather conditions, as per the National Oceanic and Atmospheric Administration (station 04924/FET), were documented and are shown in Table 28.

Table 28. Weather Conditions, Test No. BBC-7

Temperature	29° F
Humidity	56%
Wind Speed	9 mph
Wind Direction	240° from True North
Sky Conditions	Clear
Visibility	10 Statute Miles
Pavement Surface	Dry
Previous 3-Day Precipitation	0.0 in.
Previous 7-Day Precipitation	0.0 in.

16.3 Test Description

The pendulum impacted the pole system at the targeted impact height of 17½ in. (445 mm). A sequential description of the impact events is contained in Table 29.

Table 29. Sequential Description of Impact Events, Test No. BBC-7

Time (sec)	Event Description
0.000	Impact
0.009	Contact region of honeycomb element no. 1 was fully compressed.
0.017	Honeycomb element no. 2 was fully compressed.
0.026	Honeycomb element no. 3 was fully compressed.
0.033	Honeycomb element no. 4 was fully compressed.
0.045	Honeycomb element no. 5 was fully compressed.
0.048	The left-front coupling fractured.
0.049	The right-front coupling fractured.
0.052	The right-rear coupling fractured.
0.053	The left-rear coupling fractured.
0.055	Honeycomb element no. 6 was fully compressed.
0.222	The pendulum lost contact with the pole.
0.264	The base of the pole contacted the ground as the pole rotated away from its initial mounting location.
0.556	The pendulum impacted the pole for a second time on its upswing.
1.724	The top of the pole was caught by the tether ropes.
1.931	The left luminaire arm bent near the arm simplex due to the impact load caused by the tethers.
2.214	The left luminaire arm fractured away from the arm simplex.
3.034	The left luminaire arm contacted the ground after fracturing off the pole.

16.4 System Damage

Damage to the luminaire pole and brass couplings is shown in Figures 69 through 71. The pole came to rest with its base 31.5 ft (9.6 m) downstream from the initial impact location, while

the top of the pole was captured by the tether system. All four brass couplings fractured through the notch, resulting in stub heights of 1¾ in. (44 mm). The left luminaire arm fractured near the arm simplex due to the tether catching the pole as it fell. The left arm came to rest approximately 15 ft (4.6 m) upstream of impact.

16.5 Occupant Risk

The occupant impact velocity (OIV) and maximum 0.010-sec occupant ridedown acceleration (ORA) were not calculated since the hypothetical occupant did not contact the dashboard within the time that the pole was in contact with the vehicle. However, as described in Section 3.2, the pendulum’s change in velocity throughout the impact event was recorded and compared against the NCHRP Report No. 350 OIV maximum allowable limit of 16.4 ft/s (5.0 m/s). The calculated change in velocity satisfied the NCHRP Report No. 350 limit using each of the accelerometer transducers, as shown in Table 30. The recorded data from the accelerometers are shown graphically in Appendix H.

Table 30. Occupant Risk Summary, Test No. BBC-7

Evaluation Criteria	Transducer			NCHRP Report No. 350 Limit
	EDR-3	DTS		
		BF57H	CM54H	
Longitudinal OIV ft/s (m/s)	NA (No occupant contact)	NA (No occupant contact)	NA (No occupant contact)	≤ 16.4 (5.0)
Longitudinal ORA g’s	NA (No occupant contact)	NA (No occupant contact)	NA (No occupant contact)	≤ 20
Maximum Vehicle ΔV ft/s (m/s)	10.04 (3.06)	9.81 (2.99)	9.94 (3.03)	≤ 16.4 (5.0)

16.6 Discussion

The analysis of the results for test no. BBC-7 showed that the 55-ft (16.8-m) nominal height, aluminum luminaire pole with dual mast arms, simulated luminaire weights, and mounted on the Version 3 brass couplings broke away in a controlled and predictable manner. The high-speed video illustrated that the vehicle would pass underneath the luminaire pole before it fell to the ground. Therefore, the pole did not show a propensity to cause excessive deformations to the occupant compartment after it broke away. The change in velocity of the pendulum mass from initial impact until loss of contact with the test article was 9.94 ft/s (3.06 m/s), which satisfied the NCHRP Report No. 350 maximum allowable limit of 16.4 ft/s (5.0 m/s). Therefore, test no. BBC-7 (test designation no. 3-60) performed with the Version 3 brass couplings passed the TL-3 safety performance criteria provided in NCHRP Report No. 350.

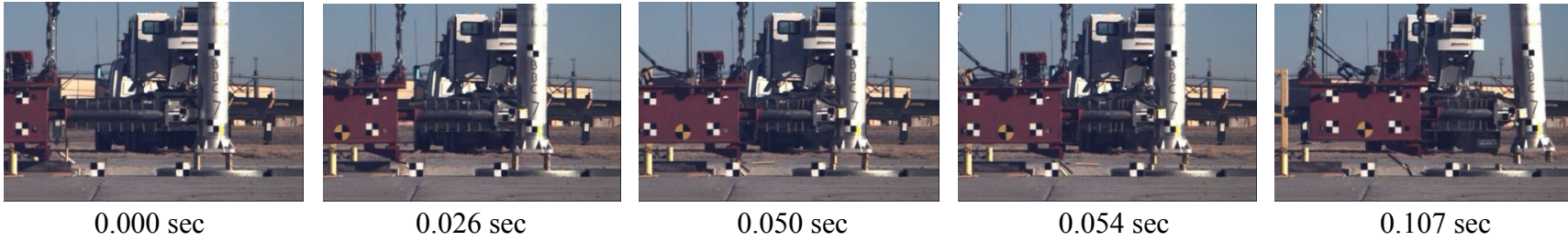

- Test Agency MwRSF
- Test Facility..... Valmont-MwRSF/UNL Pendulum
- Test Number..... BBC-7
- Date 12/1/10
- NCHRP Report No. 350 Test Designation No. 3-60
- Test Article.. Brass Couplings (Version 3) and Aluminum Pole
- Nominal Height..... 55 ft (16.8 m)
- Key Component – Tapered Aluminum Pole
 - Height 50 ft – 2 in. (15.2 m)
 - Bottom Diameter 10 in. (254 mm)
 - Thickness..... ⁵/₁₆ in. (8 mm)
- Key Component – Luminaire MastArms
 - Length..... 15 ft (4.6 m)
 - Mounting Height..... 49 ft - 6 in. (15.1 m)
- Key Component – Brass Couplings (Version 3)
 - Material..... ASTM B16 Brass
 - Shape Hexagon
 - Width 1½ in. (38.1 mm)
 - Length..... 5¼ in. (133 mm)
- Total Installation Mass 755 lb (343 kg)
 - Pole 536 lb (243 kg)
 - Arms 219 lb (99 kg)
- Surrogate Vehicle..... Pendulum
 - Mass..... 1,882 lb (854 kg)
 - Impact Head..... Crushable Nose

- Impact Conditions
 - Speed 21.8 mph (35.1 km/h)
 - Angle 0 deg
 - Impact Height..... 17½ in. (445 mm)
- Test Article Damage Minimal
- Stub Heights
 - Four Occurrences 1¾ in. (44 mm)
- Transducer Data

Evaluation Criteria	Transducer			NCHRP Report No. 350 Limit
	EDR-3	DTS		
		BF57H	CM54H	
Longitudinal OIV ft/s (m/s)	NA (No occupant contact)	NA (No occupant contact)	NA (No occupant contact)	≤ 16.4 ft/s (5.0)
Longitudinal ORA g's	NA (No occupant contact)	NA (No occupant contact)	NA (No occupant contact)	≤ 20 g's
Max. Vehicle ΔV ft/s (m/s)	10.04 (3.06)	9.81 (2.99)	9.94 (3.03)	≤ 16.4 ft/s (5.0)

Figure 66. Summary of Test Results and Sequential Photographs, Test No. BBC-7



0.000 sec



0.138 sec



0.050 sec



0.222 sec



0.054 sec



0.264 sec



0.092 sec



0.378 sec

Figure 67. Additional Sequential Photographs, Test No. BBC-7
125



0.000 sec



0.601 sec



0.067 sec



0.878 sec



0.200sec



1.869 sec



0.334 sec



2.536 sec

Figure 68. Additional Sequential Photographs, Test No. BBC-7



Figure 69. System Damage, Test No. BBC-7



Figure 70. System Damage, Test No. BBC-7



Figure 71. System Damage, Test No. BBC-7

17 ROUND 3 TESTING SUMMARY

During the Round 3 testing program, two tests were conducted to evaluate the Version 3 breakaway brass coupling according to the TL-3 safety performance criteria provided in NCHRP Report No. 350. The brass couplings were tested and evaluated while supporting both steel and aluminum versions of tall, thick luminaire poles in an effort to identify the largest poles for which the brass couplings would be appropriate for use. A summary of the testing evaluation is provided in Table 31.

In test no. BBC-6, the Version 3 breakaway brass couplings were used to support a 45-ft (13.7-m) nominal height, 7 gauge (4.55-mm thick), 900-lb (409-kg) steel luminaire pole system with dual mast arms. During this test, all four couplings fractured, and the pole broke away in a controlled and predicted manner. The remaining coupling stub heights measured $1\frac{3}{4}$ in (44 mm) high, thus satisfying the 4-in. (100-mm) maximum limit. Finally, the calculated longitudinal change in velocity of 13.25 ft/s (4.04 m/s) satisfied the NCHRP Report No. 350 maximum allowable limit of 16.4 ft/s (5.0 m/s).

In test no. BBC-7, the Version 3 breakaway brass couplings were used in combination with a 55-ft (16.8-m) nominal height, $\frac{5}{16}$ -in. (8-mm) thick, 755-lb (343-kg) aluminum luminaire pole system with dual mast arms. Shortly after impact, all four couplings fractured, and the pole broke away in a controlled and predicted manner. The remaining coupling stub heights measured $1\frac{3}{4}$ in (44 mm) high, thus satisfying the 4-in. (100-mm) maximum limit. The calculated longitudinal change in velocity of 9.94 ft/s (3.03 m/s) satisfied the NCHRP Report No. 350 maximum allowable limit of 16.4 ft/s (5.0 m/s).

Test nos. BBC-6 and BBC-7 both passed the TL-3 safety performance criteria provided in NCHRP Report No. 350 for test designation no. 3-60. Therefore, the results from these two

tests were used to calculate the results of the high-speed test using the high-speed extrapolation equation. These calculations are discussed in Chapter 18.

Table 31. Summary of Safety Performance Evaluation Results, Round Three Tests

NCHRP Report No. 350 Criteria			Test No. BBC-6	Test No. BBC-7	
Structural Adequacy	D. The test article should readily activate in a predictable manner by breaking away, fracturing or yielding.		S	S	
Occupant Risk	F. Detached elements, fragments or other debris from the test article should not penetrate or show potential for penetrating the occupant compartment or present an undue hazard to other traffic, pedestrians, or personnel in a work zone. Deformations of, or intrusions into, the occupant compartment that could cause serious injury should not be permitted. See discussion in Section 5.3 and Appendix E of NCHRP Report No. 350.		S	S	
	H. The vehicle should remain upright during and after collision although moderate roll, pitch, and yaw are acceptable.		NA	NA	
	L. Occupant Impact Velocity (OIV) (see Appendix A, Section A5.3 of NCHRP Report No. 350 for calculation procedure) should satisfy the following:		S	S	
	Occupant Impact Velocity Limits				
	Component	Preferred			Maximum
	Longitudinal	9.8 ft/s (3.0 m/s)	16.4 ft/s (5.0 m/s)		
M. The Occupant Ridedown Acceleration (ORA) (see Appendix A, Section A5.3 of NCHRP Report No. 350 for calculation procedure) should satisfy the following:		NA	NA		
Occupant Ridedown Acceleration Limits					
Component	Preferred			Maximum	
Longitudinal and Lateral	15 g's	20 g's			
Vehicle Trajectory	M. After collision it is preferable that the vehicle's trajectory not intrude into adjacent traffic lanes.		NA	NA	
	P. Vehicle trajectory behind the test article is acceptable		S	S	
AASHTO Fifth Edition Additional Criteria					
Structural Adequacy	Substantial remains of breakaway supports shall not project more than 4 in. (100 mm) above a line between straddling wheels of a vehicle on 60 in. (1500 mm) centers. The line connects any point on the ground surface one side of the support to a point on the ground surface on the other side, and it is aligned radially or perpendicularly to the centerline of the roadway.		S	S	
	The maximum mass of combined luminaire support and fixtures attached to breakaway supports shall be limited to 992 lb (450 kg). Any increase in these limits are to be based on full-scale crash testing and an investigation on the range of the roof crush characteristics that go beyond the recommended testing procedures of NCHRP Report No. 350.		S	S	

S- Satisfactory U-Unsatisfactory M-Marginal NA-Not Applicable

18 ANALYTICAL EXTRAPOLATION OF HIGH-SPEED TEST RESULTS

NCHRP Report No. 350 specifies two tests for evaluating breakaway support structures (test designation nos. 3-60 and 3-61). However, only the low-speed test (test designation no. 3-60) was conducted on each luminaire pole system using the pendulum and crushable nose. The results of the high-speed test (test designation no. 3-61) were estimated using the results from the low-speed test in combination with an analytical extrapolation method accepted by FHWA. This procedure uses the equations shown below and follows the procedure described in the noted references [4-5].

$$(\Delta MV)_H = \frac{V_L}{V_H} (\Delta MV)_L + b \left(V_H - \frac{V_L^2}{V_H} \right) \quad (\text{EQ. 1})$$

ΔMV = Vehicle momentum change

= Vehicle mass (M) x vehicle velocity change ($V_{(L \text{ or } H)} - V_x$)

$(\Delta MV)_L$ = Measured vehicle momentum change in low-speed test

$(\Delta MV)_H$ = Computed vehicle momentum change for high-speed test

V_L = Measured impact velocity during low-speed test

V_H = Extrapolated change in vehicle velocity for the high-speed test

$$b = 1.1 * M_p \left(\frac{R^2}{R^2 + D_0^2} \right)$$

M_p = Mass of system

D_0 = Distance from impact point to system center of mass

R = Radius of gyration of system about its center of mass

Since differing poles, arms, and couplings were incorporated into the various test installations, the center of gravity and radius of gyration were calculated for each individual test. The values were calculated as an assembly of 4 individual components: (1) the pole; (2) the base plate; (3) the luminaire arm; and (4) the luminaire bulb assembly. Due to the taper associated with luminaire poles, a 50-segment pole model was developed using the prescribed dimensions. The system c.g. and mass moment of inertia were calculated using this model and a lumped mass procedure. The radius of gyration, R, was then calculated as the square root of the mass moment of

inertia divided by the mass of the system. All system constants used in Equation 1 as well as the extrapolation results for the high-speed tests are shown in Table 32.

Table 32. Summary of High-Speed ΔV Results from Extrapolation Procedures

System Parameters	Test No. BBC-3	Test No. BBC-4	Test No. BBC-5	Test No. BBC-6	Test No. BBC-7
Coupling	Version 2 Brass Coupling	TRANSPO Pole-Safe	Version 2 Brass Coupling	Version 3 Brass Coupling	Version 3 Brass Coupling
Luminaire Type	Steel Pole	Steel Pole	Aluminum Pole	Steel Pole	Aluminum Pole
Nominal Height	53 ft (16.2 m)	53 ft (16.2 m)	30 ft (9.1 m)	45 ft (13.7 m)	55 ft (16.8 m)
V_L	31.9 ft/s (35.1 km/h)	34.1 ft/s (37.5 km/h)	31.9 ft/s (35.1 km/h)	32.6 ft/s (35.8 km/h)	31.9 ft/s (35.1 km/h)
V_H	91.1 ft/s (100 km/h)	91.1 ft/s (100 km/h)	91.1 ft/s (100 km/h)	91.1 ft/s (100 km/h)	91.1 ft/s (100 km/h)
Vehicle Mass	1,849 lb (839 kg)	1,849 lb (839 kg)	1,849 lb (839 kg)	1,882 lb (854 kg)	1,882 lb (854 kg)
ΔV_L (3-60)	16.40 ft/s (5.00 m/s)	15.22 ft/s (4.64 m/s)	10.24 ft/s (3.12 m/s)	13.25 ft/s (4.04 m/s)	9.94 ft/s (3.03 m/s)
M_P	923 lb (419 kg)	923 lb (419 kg)	259 lb (117 kg)	900 lb (409 kg)	755 lb (343 kg)
System c.g. Height	30.7 ft (9.4 m)	30.7 ft (9.4 m)	17.6 ft (5.4 m)	26.5 ft (8.1 m)	31.7 ft (9.7 m)
D_o	29.3 ft (8.9 m)	29.3 ft (8.9 m)	16.2 ft (4.9 m)	25.0 ft (7.6 m)	30.2 ft (9.2 m)
R	18.7 ft (5.7 m)	18.7 ft (5.7 m)	11.3 ft (3.4 m)	16.0 ft (4.8 m)	18.8 ft (5.7 m)
ΔV_H (3-61)	18.49 ft/s (5.64 m/s)	18.19 ft/s (5.54 m/s)	7.61 ft/s (2.32 m/s)	16.85 ft/s (5.14 m/s)	13.36 ft/s (4.07 m/s)

As shown above, the conservative extrapolation procedures were used to determine the high-speed, longitudinal change in velocity (ΔV_H) for three different steel luminaire pole configurations

corresponding to test nos. BBC-3, BBC-4, and BBC-6. From this analysis and for the three specific configurations, the ΔV_H values were found to exceed the NCHRP Report No. 350 maximum allowable limit of 16.4 ft/s (5.0 m/s). As such, these steel luminaire pole configurations did not meet the TL-3 safety performance criteria found in NCHRP Report No. 350 when using pendulum testing in conjunction with the conservative, high-speed extrapolation procedures. These tall, steel luminaire pole systems were found to be too massive to satisfy the ΔV_H limits when utilizing the conservative extrapolation procedures.

As discussed previously, the low-speed pendulum tests on the three steel luminaire pole configurations resulted in longitudinal changes in velocity (ΔV_L) that were equal to or below the maximum allowable limit of 16.4 ft/s (5.0 m/s). For the high-speed test condition (test designation no. 3-61), full-scale vehicle crash testing can be used in lieu of the conservative, high-speed extrapolation procedures to evaluate the safety performance of breakaway support systems. Actual full-scale vehicle crash testing may provide lower ΔV_H values than those determined above. If full-scale vehicle crash testing had been performed, some of these steel pole configurations may have demonstrated acceptable safety performance according to the NCHRP Report No. 350 guidelines. However, time and cost restraints did not allow for the use of full-scale vehicle crash testing according to test designation no. 3-61, and the high-speed extrapolation procedures were used.

As a result, an upper bound was needed for the acceptable steel luminaire pole sizes that could be used with the breakaway brass couplings. Altering the luminaire pole and mast arm system to either a shorter or thinner gauge pole may satisfy the ΔV_H limits of NCHRP Report No. 350 and provide an acceptable configuration. This philosophy was explored using the pendulum testing results with the extrapolation equation and is described in Chapter 19.

For the short, aluminum luminaire pole system used in test no. BBC-5, the ΔV_H was calculated to be 7.61 ft/s (2.32 m/s), which was lower than the safety performance limit as well as the low-speed change in velocity (ΔV_L) result of 10.24 ft/s (3.12 m/s). This finding was expected as breakaway systems weighing less than 400 lb (182 kg) have regularly been shown to produce a lower ΔV_H than the ΔV_L due to the higher impact energy in test designation no. 3-61 and the low rotational inertia for lighter systems. From test no. BBC-5, the low-speed change in velocity (ΔV_L) and the extrapolated high-speed change in velocity (ΔV_H) satisfied the safety performance criteria found in NCHRP Report No. 350 and the AASHTO Standard Specifications. As such, the breakaway brass couplings were deemed crashworthy when used in combination with a 30-ft (9.1-m) nominal height, 1/4-in. (6.4 mm) thick, aluminum luminaire pole system.

For test no. BBC-7, the tall, heavy, aluminum luminaire pole system also showed favorable results as the ΔV_H was calculated to be 13.36 ft/s (4.07 m/s). In this test, the low-speed change in velocity (ΔV_L) and the extrapolated high-speed change in velocity (ΔV_H) satisfied the safety performance criteria found in NCHRP Report No. 350 and the AASHTO Standard Specifications. As such, the breakaway brass couplings were deemed crashworthy when used in combination with a 55-ft (16.8-m) nominal height, 755 lb (343 kg) aluminum luminaire pole system.

In summary, the short aluminum luminaire pole system (test no. BBC-5) and the tall, heavy, aluminum luminaire pole system (test no. BBC-7) satisfied the safety requirements. Thus, other aluminum poles with heights, weights, and thicknesses ranging between those used in the as-tested luminaire pole systems would also be expected to satisfy the safety performance criteria provided in NCHRP Report No. 350.

19 STEEL LUMINAIRE POLE ANALYSIS

Equation 1 provides the primary extrapolation equation for determining the change in velocity for the high-speed test condition and can be described as a combination of two terms. The first term, $\frac{V_L}{V_H}(\Delta MV)_L$, is comprised of the ratio of test impact speeds multiplied by the change in momentum during the low-speed test. The second term in Equation 1, $b\left(V_H - \frac{V_L^2}{V_H}\right)$, is comprised of a factor relating impact speeds, which is multiplied by a geometric or inertial factor. Since the impact speeds for the low- and high-speed tests are targeted at 21.7 mph (35.0 km/h) and 62.1 mph (100.0 km/h), respectively, the first term contributes roughly one third of the low-speed momentum change to the extrapolated high-speed momentum change. As a result, the majority of the high-speed momentum change is the result of the second term, or more specifically, the geometry and inertial properties of the system. Further, using poles of varying sizes and weights can greatly affect the change in momentum/velocity. In other words, a lighter system weight or a more optimum system configuration may result in a satisfactory change in momentum/velocity. Therefore, the extrapolation equation was used in combination with the geometrical properties of various steel luminaire poles to identify the upper bound for steel pole sizes that could be used with the breakaway brass couplings.

19.1 Analysis Methodology and Procedure

As discussed previously, the largest contribution to the change in momentum/velocity was a result of the system's geometry and mass distribution, which comprises the 'b' variable in the second term of Equation 1. Therefore, each configuration required accurate calculations for the center of gravity (c.g.), the mass moment of inertia, the radius of gyration, and the resulting 'b' term. The system c.g. was calculated as an assembly of 4 individual components: (1) the pole; (2) the base plate; (3) the luminaire arm; and (4) the luminaire bulb assembly. Due to the taper

associated with luminaire poles, a 50-segment pole model was developed using the prescribed dimensions, and the pole c.g. was calculated using a lumped mass procedure. The luminaire arms remained mounted at a constant distance from the top of the pole, 6 in. (152 mm) as measured from test no. BBC-6, while the simulated luminaire bulb assembly was taken to be 5 ft (1.5 m) above the top of the pole. The base plate c.g. was always placed at ground level. Although the weight of the pole was calculated for each individual system, the mast arms, simulated luminaire bulb assembly, and base plate weights remained constant to the measured values taken from test no. BBC-6.

The system mass moment of inertia was calculated using the same lumped mass model described previously and the calculated center of gravity for the system. Only the weight and vertical location of each component, or segment, was used in the mass moment of inertia calculations. The radius of gyration, R , was then calculated as the square root of the mass moment of inertia divided by the mass of the system.

The low-speed change in momentum/velocity in Equation 1 was held constant and taken from the test no. BBC-6. Recall that this test involved a tall, heavy, steel pole with a large mass moment of inertia, or rotational resistance, where the calculated ΔV_H exceeded the NCHRP Report No. 350 limit. Thus, the pole was deemed too large or massive for use with the breakaway brass couplings. Thus, the extrapolation analysis focused on the use of steel poles with either (1) same thickness but shorter or (2) thinner but taller. The alternative pole systems would have lower rotational inertia values and would be expected to produce lower ΔV_L values if actually tested. Therefore, using the ΔV_L value obtained in test no. BBC-6 was deemed to be a conservative approach.

The remaining variables used in Equation 1 were held constant to the prescribed testing conditions. The impact height was set at 17½ in. (445 mm). The low- and high-speed velocities

were set to the low- and high-speed test velocities prescribed by NCHRP Report No. 350, $V_L = 21.7$ mph (35.0 km/h) and $V_H = 62.1$ mph (100.0 km/h), respectively.

The geometrical factors that affect the rotational inertia of the pole itself are the height, the thickness, and the shaft diameter. To reduce the number of steel shafts to be evaluated during this study, the base diameter was held constant at 10 in. (254 mm) and a constant taper of 0.14 in./ft was applied to all theoretical poles. Thus, only the shaft height and thickness were changed. Pole thicknesses ranged between 7 gauge (4.55 mm) and 11 gauge (3.03 mm). For each of the five thicknesses, the height of the shaft was altered until the maximum height which satisfied the ΔV_H limit of 16.4 ft/s (5.0 m/s) was determined.

19.2 Results

The results of the maximum-size steel pole study are shown in Table 33. For a pole with a 7-gauge (4.55-mm) wall thickness, the maximum shaft and nominal heights were found to be 36 ft (11.0 m) and 41 ft (12.5 m), respectively. The calculated maximum height pole is only 4 ft (1.2 m) shorter than the pole system utilized in test no. BBC-6. This minor deviation was expected, because the calculated high-speed change in velocity for that system, 16.85 ft/s (5.14 m/s), was just slightly over the NCHRP Report No. 350 limit. As the thickness of the shaft was reduced, the maximum allowable height increased by approximately 5 ft (1.5 m) per reduction in gauge thickness. It should be noted that the maximum nominal height of the system was capped at 60 ft (18.3 m). As a result and as shown in Table 33, the 11-gauge (3.03-mm) thick pole system only had a calculated ΔV_H of 15.22 ft/s (4.64 m/s), while the remainder of the pole systems had ΔV_H values much closer to the 16.4 ft/s (5.00 m/s) limit.

This analysis held the pole base diameter and base plate weight constant. In reality, these values would be expected to increase with an increase in system height. The luminaire arms may

also have varying sizes and weights depending on the application. A change in these parameters in favor of larger dimensions or heavier weights would alter the mass distribution of the luminaire pole system, thus potentially leading to an increase in the calculated high-speed, longitudinal change in velocity (ΔV_H). However, changes to these parameters in favor of smaller and/or lighter components would only reduce the rotational inertia and create a more favorable system. As a result, Table 33 should only be used as a general guide for selecting luminaire poles with a maximum base diameter of 10 in. (254 mm). Any pole with a greater base diameter would need to be individually analyzed using the high-speed extrapolation equation and either the methodologies described in Section 19.1 or another procedure to accurately calculate the system c.g. height and mass moment of inertia.

Table 33. Maximum Size of Steel Pole Results

Shaft Thickness	Shaft Height	Nominal Height	System Mass	System c.g. Height	Do	R	ΔV_H
7 gauge (4.55 mm)	36 ft (11.0 m)	41 ft (12.5 m)	872 lb (396 kg)	23.8 ft (7.3 m)	22.7 ft (6.9 m)	14.4 ft (4.4 m)	16.31 ft/s (4.97 m/s)
8 gauge (4.18 mm)	41 ft (12.5 m)	46 ft (14.0 m)	871 lb (395 kg)	26.7 ft (8.1 m)	25.6 ft (7.8 m)	16.3 ft (5.0 m)	16.39 ft/s (5.00 m/s)
9 gauge (3.80 mm)	46 ft (14.0 m)	51 ft (15.5 m)	856 lb (389 kg)	29.6 ft (9.0 m)	28.6 ft (8.7 m)	18.3 ft (5.6 m)	16.28 ft/s (4.96 m/s)
10 gauge (3.42 mm)	54 ft (16.5 m)	59 ft (18.0 m)	841 (382 kg)	34.1 ft (10.4 m)	33.1 ft (10.1 m)	21.6 ft (6.6 m)	16.35 ft/s (4.98 m/s)
11 gauge (3.03 mm)	55 ft (16.8 m)	60 ft (18.3 m)	782 lb (355 kg)	35.7 ft (10.9 m)	34.7 ft (10.6 m)	22.1 ft (6.7 m)	15.22 ft/s (4.64 m/s)

20 SUMMARY, CONCLUSIONS AND RECOMMENDATIONS

The objective of this research project was to evaluate the safety performance of the ILDOT's breakaway brass couplings used in combination with steel and aluminum luminaire poles. More specifically, the new brass couplings were evaluated in terms of their ability to breakaway when struck by an errant vehicle. The couplings were (1) fabricated from ASTM B16, free-cutting brass, (2) drilled and tapped for 1 in. – 8UNC threaded bars, and (3) had a circumferential notch cut around its outer surface to induce fracture.

The evaluation process began with a physical impact testing program that was conducted at the Valmont/UNL-MwRSF pendulum testing facility. Initially, the brass couplings were configured with both a large, heavy luminaire pole as well as a smaller, lighter, and weaker aluminum luminaire pole. The large steel pole system was selected to determine the upper bound of acceptable luminaire poles as it provided a high rotational inertia and was believed to dissipate the most energy during the activation of the breakaway mechanism. The smaller pole was selected to determine the lower bound of acceptable luminaire poles and ensure that the brass couplings would fracture before the pole would bend, fracture, or crush. The pendulum mass was configured with crushable nose and used to test and evaluate the breakaway support systems at a speed of 22 mph (35 km/h) and in compliance with test designation no. 3-60 of NCHRP Report No. 350.

In lieu of conducting the high-speed impact test also required by NCHRP Report No. 350, test designation no. 3-61, an analytical extrapolation procedure was used to conservatively predict the high-speed, longitudinal change in velocity. This analytical method was developed at ENSCO, INC. and has been approved by the FWHA. The extrapolation procedure uses the change in velocity from the low-speed impact test, the mass distribution of the luminaire pole system, and fundamental physics principles to extrapolate the vehicle's longitudinal change in velocity for the high-speed

test. This extrapolation procedure was conducted on any system that satisfied the safety performance criteria for the low-speed test.

During the Round 1 testing program, test nos. BBC-1 and BBC-2, the original brass couplings (Version 1) proved stronger than anticipated and resulted in changes in velocity that were higher than the maximum allowable limit. As a result, the brass couplings were redesigned. The Version 2 brass couplings did not include the internal nylon spacer inserts and utilized set screws to ensure the anchor bolts would not be threaded through the center notch region. In addition, the notch radius was decreased to create a higher stress concentration, and the notch depth was increased to reduce the cross-sectional area of the fracture surface. All of these changes were aimed at reducing the strength of the couplings and reducing the time to fracture.

During the Round 2 testing program, test nos. BBC-3 through BBC-5, the Version 2 brass couplings were used to support the same two poles that were used in the Round 1 testing program. In test no. BBC-3, the brass couplings fractured, but the calculated low-speed, longitudinal change in velocity (ΔV_L) was at the 16.4 ft/s (5.0 m/s) limit. As a result, the high-speed longitudinal change in velocity (ΔV_H) was well over the limit when utilizing the high-speed extrapolation equation to evaluate the results for test designation no. 3-61. Similarly and for test no. BBC-4, the heavy steel pole was mounted on the previously-tested and FHWA-accepted TRANSPO Pole-Safe couplings. For this test, the low-speed change in velocity (ΔV_L) was satisfactory, but the extrapolated, high-speed, longitudinal change in velocity (ΔV_H) exceeded the performance limit. Since the tall, heavy, steel pole resulted in high-speed test failures for both the brass coupling as well as the TRANSPO coupling, the tall, heavy steel pole was determined to be too massive to satisfy the ΔV_H limit, and a different steel pole was selected for Round 3 testing program.

During test no. BBC-5, the brass couplings fractured through the center notch and allowed the aluminum luminaire pole system to rotate away from its initial ground attachment location. The measured ΔV_L as well as the extrapolated ΔV_H both satisfied the NCHRP Report No. 350 maximum allowable limit of 16.4 ft/s (5.0 m/s). The remaining coupling stub heights were all 1 $\frac{3}{4}$ in. (38 mm), satisfying the 4-in. (100-mm) limit. Therefore, the smaller aluminum pole system met the TL-3 safety performance criteria found in NCHRP Report No. 350 and established a lower bound for the acceptable luminaire pole configuration for use with the breakaway brass couplings.

Prior to conducting the Round 3 pendulum testing, the brass couplings were again redesigned. The Version 3 brass couplings had an extended upper segment, resulting in an overall height increase. All other coupling characteristics, including notch radius and depth, notch distance from the bottom, coupling width, and material, remained the same. The upper segment of the coupling was doubled in length in order to increase the bending stresses in the notch that resulted from the impact loads. Thus, the fracture strength of the coupling was reduced. The final dimensions for the breakaway brass couplings are shown in Figures 54 and 55.

As stated previously, the heavy, steel pole utilized in the Rounds 1 and 2 testing programs was deemed too massive to satisfy the ΔV limits, especially for the high-speed test. As a result, a shorter, 45-ft (13.7-m) nominal height, steel luminaire pole was selected for use in the Round 3 testing program. However, the ILDOT representatives desired to utilize the brass couplings with taller poles. The difference in density between steel and aluminum is significant. Thus, tall poles could be configured from aluminum versus steel and meet the impact safety standards due to a significantly lower rotational inertia for the same-size poles. Therefore, a 55-ft (16.8-m) nominal height, aluminum luminaire pole was also selected for testing and evaluation.

During test no. BBC-7, the breakaway brass couplings fractured and allowed the tall, aluminum luminaire pole system to rotate away from its initial ground attachment location. The remaining coupling stub heights were 1¾ in. (38 mm), satisfying the 4-in. (100-mm) limit. Both the measured ΔV_L and the extrapolated ΔV_H satisfied the NCHRP Report No. 350 maximum allowable limit of 16.4 ft/s (5.0 m/s). Therefore, aluminum luminaire poles of nominal heights ranging between 30 ft (9.1 m) and 55 ft (16.8 m), minimum wall thicknesses of ¼ in. (6.4 mm), and weights equal to or less than 755 lb (343 kg) should be acceptable for use with the breakaway brass couplings and meet the TL-3 impact safety standards.

Although test no. BBC-5 was conducted with the smaller aluminum pole mounted to the Version 2 breakaway brass couplings, the low-speed change in velocity ΔV_L and the extrapolated ΔV_H were believed to be conservative estimates for the Version 3 breakaway brass couplings. The only difference between Version 2 and Version 3 couplings was the distance between the notch and top of the coupling as well as overall coupling height. As explained in Chapter 14, this change lowered its impact resistance and effectively shorted the time to fracture. Therefore, a similar test conducted on Version 3 breakaway brass couplings would result in lower ΔV_L and ΔV_H values. Subsequently, the Version 3 brass couplings were deemed to meet the TL-3 impact safety standards when utilized with a 30 ft (9.1 m) nominal height, aluminum luminaire pole system.

For test no. BBC-6, the Version 3 brass couplings were used to support a 45-ft (13.7-m) nominal height, steel luminaire pole system. During the impact event, all four couplings fractured, thus leaving stub heights of 1¾ in. (38mm). In the test, the pole system rotated away from its initial attachment location. The measured ΔV_L was 13.25 ft/s (4.04 m/s), which satisfied the NCHRP Report No. 350 maximum allowable limit of 16.4 ft/s (5.0 m/s). However, the extrapolated ΔV_H was calculated to be 16.85 ft/s (5.14 m/s). As a result, the 45-ft (13.7-m) nominal height, steel

luminaire system did not meet the TL-3 safety performance criteria and was not approved for use with the breakaway brass couplings.

To identify the largest steel luminaire poles that can be used in combination with the breakaway brass couplings, further analysis was undertaken using the high-speed extrapolation equation to predict the ΔV_H for different size poles. Steel luminaire pole configurations with varying thickness and height were analyzed to determine the extrapolated high-speed, change in longitudinal velocity (ΔV_H). These extrapolated values were compared to the maximum allowable limit of 16.4 ft/s (5.0 m/s) in order to determine whether specific poles were acceptable for use with the brass couplings. During this study, the luminaire arms, base plate, and pole base diameter were held constant to the dimensions and weights corresponding to those used in test no. BBC-6. Thus, only the shaft thickness and heights were altered. This analysis yielded the maximum shaft height for poles with a wall thickness ranging between 7 gauge (4.55 mm) and 11 gauge (3.03 mm). For a 7-gauge (4.55-mm) wall thickness or the same thickness as used in test no. BBC-6, the maximum shaft height was determined to be 36 ft (11.0 m). The results from this analysis for all wall thicknesses are shown in Table 33.

These steel pole results (as shown in Table 33) are valid for luminaire pole configurations using system parameters similar to those used in test no. BBC-6. Since the pole's base diameter was held constant at 10 in. (254 mm) throughout the analysis, only pole shaft diameters equal to or less than 10 in. (254 mm) are applicable to the results shown in the noted table. Poles with larger diameters must to be analyzed independently using the proposed system's mass distribution and the ΔV_H extrapolation calculation presented in Chapter 19. Similarly, the mast arms were held constant throughout the analysis. Thus, luminaire pole systems utilizing mast arm configurations other than the truss type luminaire arms need to be analyzed on a case-by-case basis.

A summary of all of the applicable luminaire poles for use with the breakaway brass couplings (Version 3) is shown in Table 34. Since the maximum sizes for the steel luminaire pole systems were established using the high-speed extrapolation procedure assuming truss arms with a 5-ft (1.5-m) rise height, this table applies only to truss arm configurations. Any desired steel luminaire pole system within 5 ft of the maximum nominal height must either utilize these truss arms, or a separate analysis must be conducted.

Table 34. Applicable Luminaire Pole Systems for Use with the Brass Breakaway Couplings

Pole Type	Thickness	Base Diameter		Nominal Height		System Weight	
		Min.	Max.	Min.	Max.	Min.	Max.
Aluminum	≥ ¼ in. (≥ 6.4 mm)	8 in. (203 mm)	10 in. (254 mm)	30 ft (9.1 m)	55 ft (16.8 m)	259 lb (118 kg)	755 lb (343 kg)
Steel	7 gauge (4.55 mm)	NA	10 in. (254 mm)	30 ft (9.1 m)	41 ft (12.5 m)	259 lb (118 kg)	900 lb (409 kg)
	8 gauge (4.18 mm)	NA	10 in. (254 mm)	30 ft (9.1 m)	46 ft (14.0 m)	259 lb (118 kg)	900 lb (409 kg)
	9 gauge (3.80 mm)	NA	10 in. (254 mm)	30 ft (9.1 m)	51 ft (15.5 m)	259 lb (118 kg)	900 lb (409 kg)
	10 gauge (3.42 mm)	NA	10 in. (254 mm)	30 ft (9.1 m)	59 ft (18.0 m)	259 lb (118 kg)	900 lb (409 kg)
	11 gauge (3.03 mm)	NA	10 in. (254 mm)	30 ft (9.1 m)	60 ft (18.3 m)	259 lb (118 kg)	900 lb (409 kg)

21 REFERENCES

1. Ross, H.E., Sicking, D.L., Zimmer, R.A., and Michie, J.D., *Recommended Procedures for the Safety Performance Evaluation of Highway Features*, National Cooperative Highway Research Program (NCHRP) Report No. 350, Transportation Research Board, Washington, D.C., 1993.
2. American Association of State Highway Transportation Officials (AASHTO), *Standard Specifications for Structural Supports for Highway Signs, Luminaires, and Traffic Signals*, 5th Edition, Washington D.C., 2009.
3. Bielenberg, R.W, Lechtenberg, K.A., Faller, R.K., and Sicking, D.L., *Validation of the Valmont/MwRSF Pendulum with Crushable Nose*, Research Report No. TRP-03-214-09, Midwest Roadside Safety Facility, University of Nebraska-Lincoln, Lincoln, Nebraska, February 2009.
4. Owings, R.P, Adair, J.W., and Cantor, C., *Safer Sign and Luminaire Supports – Task L – Final Report*, Report No. FHWA-RD-76-36, ENSCO, INC., Springfield Virginia, October 1975.
5. Steinke, D.P., *FHWA Memorandum HNG-14 for Action: Identifying Acceptable Highway Safety Features*, To Regional Administrators, Federal Lands Highway Program Administrator, Division Administrators, and Federal Lands Highway Division Engineers, July 25, 1997.
6. Hott, C., Brown, C., and Totani, N., *Crush Characteristics of the 1,800 lb Pendulum*, Report No. FHWA-RD-90-059, The Scientex Corporation of Washington, D.C. and Federal Highway Administration, Turner-Fairbank Highway Research Center, McLean, Virginia, July 1990.
7. Hott, C., Brown, C., Totani, N., and Hansen, A., *Crush Characteristics of the Breakaway Bogie*, Report No. FHWA-RD-89-107, Federal Highway Administration, Washington, D.C., March 1989.
8. Zimmer, R.A. and A.G. Arnold, *Calibration of the TTI 820 KG Pendulum*, Report 270687, Texas Transportation Institute, College Station, Texas, June 1997.
9. Sillan, S.I., FHWA NCHRP Report 350 Approval Letter LS-45B of the TRANSPO Industries Pole-Safe Double Neck Coupling, to Tauhid Husain, TRANSPO Industries, March 5, 1996.
10. LaTurner, J.F., *NCHRP Report 350 Crash Test Results for the Pole-Safe® Breakaway Coupling (Double Neck Series 4000 and 5000)*, Final Report, Project No. 03-8287, E-TECH Testing Services, Inc., Rocklin, California, October 1996.

22 APPENDICES

Appendix A. Material Specifications



PLASCORE

CERTIFICATE OF CONFORMANCE

Date : 02-06-2009

To : VALMONT INDUSTRIES, INC.
VALLEY MRO STOREROOM
7002 NORTH 288TH STREET
PO BOX 358

PURCHASE ORDER INFORMATION

Customer P.O. Number : 99801989
Work Order Number : 221619
Quantity : 96 pieces
Size : 3.250 " x 16.000 " x 2.750 "
Customer Part Number : 130 PSI

CORE INFORMATION

Core Type : PAMG-XR1-A31316N5052T
Foil Gauge : 001
Coil Number : 208-1820/2
Core Block Number : A31316N5052.48X96*043A1208
Measured Density : 3.02 lb/cu.ft
Measured Cell Size : .199 Inches

1

This is to certify that the aluminum honeycomb core supplied meets the crush requirements of 130 +/- 10%.

Quality Control Representative

Plascore
008

PLASCORE INC. * 615 N. FAIRVIEW ST. * P.O. BOX 170 * ZEELAND, MI 49464-0170
PHONE(616)772-1220 * FAX(616)772-1289

Figure A-1. Aluminum Honeycomb Element No. 1 Material Certification



PLASCORE

CERTIFICATE OF CONFORMANCE

Date : 02-09-2009

To : VALMONT INDUSTRIES, INC.
VALLEY MRO STOREROOM
7002 NORTH 288TH STREET
PO BOX 358

PURCHASE ORDER INFORMATION

Customer P.O. Number : 99801989
Work Order Number : 221618
Quantity : 32 pieces
Size : 2.250 " x 4.000 " x 5.000 "
Customer Part Number : 25 PSI

CORE INFORMATION

Core Type : PCGA-XR1-A1410N3003T
Foil Gauge : 003
Coil Number : 204-1757/27
Core Block Number : A1410N3003.37X96*124B1204
Measured Density : 1.4 lb/cu.ft
Measured Cell Size : 1.0 Inches

#2

This is to certify that the aluminum honeycomb core supplied meets the crush requirements of 25 +/- 10%.

Quality Control Representative



PLASCORE INC. * 615 N. FAIRVIEW ST. * P.O. BOX 170 * ZEELAND, MI 49464-0170
PHONE(616)772-1220 * FAX(616)772-1289

Figure A-2. Aluminum Honeycomb Element No. 2 Material Certification



PLASCORE

CERTIFICATE OF CONFORMANCE

Date : 02-06-2009

To : VALMONT INDUSTRIES, INC.
VALLEY MRO STOREROOM
7002 NORTH 288TH STREET
PO BOX 358

PURCHASE ORDER INFORMATION

Customer P.O. Number : 99801989
Work Order Number : 221620
Quantity : 96 pieces
Size : 3.250 " x 8.000 " x 8.000 "
Customer Part Number : 130 PSI

CORE INFORMATION

Core Type : PAMG-XR1-A31316N5052T
Foil Gauge : 001
Coil Number : 208-1820/2
Core Block Number : A31316N5052.48X96*043A1208
Measured Density : 3.02 lb/cu.ft
Measured Cell Size : .199 Inches

3

This is to certify that the aluminum honeycomb core supplied meets the crush requirements of 130 +/- 10%.

Quality Control Representative



PLASCORE INC. * 615 N. FAIRVIEW ST. * P.O. BOX 170 * ZEELAND, MI 49464-0170
PHONE(616)772-1220 * FAX(616)772-1289

Figure A-3. Aluminum Honeycomb Element No. 3 Material Certification



PLASCORE

CERTIFICATE OF CONFORMANCE

Date : 02-06-2009

To : VALMONT INDUSTRIES, INC.
VALLEY MRO STOREROOM
7002 NORTH 288TH STREET
PO BOX 358

PURCHASE ORDER INFORMATION

Customer P.O. Number : 99801989
Work Order Number : 221621
Quantity : 288 pieces
Size : 3.250 " x 8.000 " x 8.000 "
Customer Part Number : 230 PSI

CORE INFORMATION

Core Type : PAMG-XR1-A4314N5052T
Foil Gauge : 002
Coil Number : 208-2133/2
Core Block Number : A4314N5052.48X96*147B1008
Measured Density : 3.96 lb/cu.ft
Measured Cell Size : .257 Inches

4 #5,
#6

This is to certify that the aluminum honeycomb core supplied meets the crush requirements of 230 +/- 10%.

Quality Control Representative

Plascore
008

PLASCORE INC. * 615 N. FAIRVIEW ST. * P.O. BOX 170 * ZEELAND, MI 49464-0170
PHONE(616)772-1220 * FAX(616)772-1289

Figure A-4. Aluminum Honeycomb Element Nos. 4 through 6 Material Certification



PLASCORE

CERTIFICATE OF CONFORMANCE

Date : 02-06-2009

To : VALMONT INDUSTRIES, INC.
VALLEY MRO STOREROOM
7002 NORTH 288TH STREET
PO BOX 358

PURCHASE ORDER INFORMATION

Customer P.O. Number : 99801989
Work Order Number : 221622
Quantity : 288 pieces
Size : 3.250 " x 8.000 " x 8.000 "
Customer Part Number : 400 PSI

CORE INFORMATION

Core Type : PAMG-XR1-A57316N5052T
Foil Gauge : 002
Coil Number : 208-3039/1
Core Block Number : A57316N5052.48X96*094A0109
Measured Density : lb/cu.ft
Measured Cell Size : Inches

#7, #8, #9

This is to certify that the aluminum honeycomb core supplied meets the crush requirements of 400 +/-10%.

Quality Control Representative

Plascore
008

PLASCORE INC. * 615 N. FAIRVIEW ST. * P.O. BOX 170 * ZEELAND, MI 49464-0170
PHONE(616)772-1220 * FAX(616)772-1289

Figure A-5. Aluminum Honeycomb Element Nos. 7 through 9 Material Certification



PLASCORE

CERTIFICATE OF CONFORMANCE

Date : 02-06-2009

To : VALMONT INDUSTRIES, INC.
VALLEY MRO STOREROOM
7002 NORTH 288TH STREET
PO BOX 358

PURCHASE ORDER INFORMATION

Customer P.O. Number : 99801989
Work Order Number : 221623
Quantity : 96 pieces
Size : 3.250 " x 8.000 " x 10.000 "
Customer Part Number : 400 PSI

CORE INFORMATION

Core Type : PAMG-XR1-A57316N5052T
Foil Gauge : 002
Coil Number : 208-3039/1
Core Block Number : A57316N5052.48X96*094A0109
Measured Density : lb/cu.ft
Measured Cell Size : Inches

10

This is to certify that the aluminum honeycomb core supplied meets the crush requirements of 400 +/-10%.

Quality Control Representative

Plascore
008

PLASCORE INC. * 615 N. FAIRVIEW ST. * P.O. BOX 170 * ZEELAND, MI 49464-0170
PHONE(616)772-1220 * FAX(616)772-1289

Figure A-6. Aluminum Honeycomb Element No. 10 Material Certification

CHICAGO SPECTRO SERVICE LABORATORY, INC.
Spectrographic and Chemical Analysts
Metallurgists



6245 S. OAK PARK AVE. • CHICAGO, IL 60638-4015
TELEPHONE: 773-229-0099 • FAX: 773-229-0313
EMAIL: chicagospectro@core.com

#0781-01
ANALYSIS REPORT FOR:

University of Illinois
Attention: Dr. Greg Banas, 1135 NCEI
205 N. Mathews Ave.
Urbana, IL 61801-2397

PURCHASE ORDER NO.

DATE 10/21/09

Report Number: G6061

SUBJECT: Chemical composition and Alloy type of sample received 10/19/09

CHEMICAL COMPOSITION:

Copper	60.07 %
Manganese	0.01
Nickel	0.10
Lead	2.76
Tin	0.19
Iron	0.27
Zinc	Balance

ALLOY TYPE: C360

TEST METHODS: ASTM F478; ASTM E1621

Page 1 of 1

CHICAGO SPECTRO SERVICE LABORATORY, INC.

By 

"THE FOREGOING REPORT IS FURNISHED BY US PURSUANT TO CONTRACT AND IN STRICT CONFIDENCE. NO PART HEREOF MAY BE REPRODUCED FOR PUBLICATION WITHOUT OUR PRIOR WRITTEN APPROVAL."

Figure A-7. Brass Coupling Material Certification, Test Nos. BBC-1 and BBC-2

APR-21-2010 18:11
13-04-2010 08:33 AM

IDOT

217 782 2572 P.02/02

CHICAGO SPECTRO SERVICE LABORATORY, INC.
Spectrographic and Chemical Analysts
Metallurgists



#0781-01
ANALYSIS REPORT FOR:

6245 S. OAK PARK AVE. • CHICAGO, IL 60638-4015
TELEPHONE: 773-229-0099 • FAX: 773-229-0313
EMAIL: chicagospectro@core.com

IDOT
Attention: Christopher Hahin
126 East Ash Street
Springfield, IL 62704-4766

PURCHASE ORDER NO. FPA433976

DATE 4/13/10

Report Number: G8195

SUBJECT: Chemical composition of sample received 4/12/10

SAMPLE IDENTIFICATION/DESCRIPTION: Brass

CHEMICAL COMPOSITION:

Copper	61.03 %
Lead	2.82
Tin	0.11
Manganese	0.02
Silicon	< 0.01
Iron	0.16
Nickel	0.04
Zinc	Balance

TEST METHODS: ASTM E478; ASTM E1621

Page 1 of 1

CHICAGO SPECTRO SERVICE LABORATORY, INC.
By 

"THE FOREGOING REPORT IS FURNISHED BY US PURSUANT TO CONTRACT AND IN STRICT CONFIDENCE. NO PART HEREOF MAY BE REPRODUCED FOR PUBLICATION WITHOUT OUR PRIOR WRITTEN APPROVAL."

TOTAL P.02

Figure A-8. Brass Material Certification, Test Nos. BBC-3 and BBC-5 Through BBC- 7

MSi Testing & Engineering, Inc.

Your Source for Metallurgical Testing and Failure Analysis

1390 N. 25th Avenue
Melrose Park, IL 60160
708-343-3444
F A X-3033



Illinois DOT Materials
126 E. Ash Street
Springfield, IL 60704

Report No.: 151842
Date: 10-27-09
Order No.: FPA 315344
Page: 1 of 1

Attn: Mr. Chris Hahin

SAMPLE IDENTIFICATION

Material	Condition	Description
316 Stainless Steel	Cold Drawn or Worked	Thread Stock

TEST RESULTS *

Chemical Testing

Carbon	.020 %
Manganese	1.50
Phosphorus	.035
Sulfur	.026
Silicon	.47
Nickel	10.30
Chromium	16.24
Molybdenum	2.02
Copper	.54
Nitrogen	.05
Titanium	<.01

Hardness Testing

	Core	1/3 R	2/3 R
Hardness, HRC	24	27	30

* Testing performed in accordance with ASTM E1086, E18 and MSi Procedure No. 1002.

Respectfully Submitted,
MSi Testing & Engineering, Inc.

Bart Bobek

BB/oa/E-Document

Bart Bobek
Associate Metallurgical Engineer

The Above Test Report Relates Only To The Items Tested And Shall Not Be Reproduced Except In Full, Without The Written Consent Of MSi Testing & Engineering, Inc.
All Specimen Remnants Pertaining To The Above Tested Items Are Retained For a Maximum Of 30 Days, Unless Notified In Writing.
Template: Reports_Report TemplatesNew Client - address.doc

Figure A-9. Threaded Rod For Brass Couplings Material Certification



SEVERSTAL WHEELING INC
STEUBENVILLE PLANT

CERTIFICATE OF ANALYSIS AND TESTS

PAGE 1 OF 1

TESTING CERTIFICATE 0341.C

CHARGED TO
VALMONT INDUSTRIES INC.
HWY 275
P.O. BOX 358
VALLEY NE
TUBING DIVISION

68064

SHIPPED TO
VALMONT INDUSTRIES INC.
IPD
HWY 64
VALLEY NE
0000081WEST

68064

ASTM STANDARD COMPLIANCE:
CHEMICAL- E415
MECHANICAL- E8, E18

CUST ORD. PO1196-2
THICKNESS .1510 IN

MILL ORDER NO. 018-018983-01
WIDTH 38.0000 IN

PART NO # 4165138

SPECIFICATION AND DESCRIPTION:
HOT ROLLED SHEET COIL UNPROCESSED:DOMESTIC STEEL ONLY:C-1015:CS:DRY:MIN GAUGE MILL EDGE

HEAT NO.	C	MN	P	S	SI	CU	NI	CR	MO	AL	CB	V	TI	N	B
E90628	.15	0.34	.008	.004	.022	.12	.04	.04	.01	.040	.000	.002	.002	.0072	.0001

VALMONT INDUSTRIES INC. *
HWY 275
P.O. BOX 358
VALLEY NE
TUBING DIVISION
68064

VALMONT INDUSTRIES INC.
IPD
HWY 64
VALLEY NE
0000081WEST
68064

THIS IS TO CERTIFY THAT THE CHEMICAL ANALYSIS AND/OR MECHANICAL PROPERTIES ON THE MATERIAL REPORTED ABOVE ARE CORRECT AS CONTAINED IN OUR RECORDS. MELTED AND MANUFACTURED IN THE USA

BY: *Glenn A. Shaw* TITLE: LAB METALLURGIST DATE: 03/19/09
NOTE: THIS REPORT MAY NOT BE COPIED EXCEPT BY WRITTEN PERMISSION OF SEVERSTAL WHEELING INC

159

Figure A-10. Steel Pole Material Certification, Test Nos. BBC-1, BBC-3, and BBC-4



REPORT OF PHYSICAL AND CHEMICAL TESTS

Date: JUNE 20, 2009
Customer: VALMONT INDUSTRIES INC
Customer PO#: 71115

Lot#: 53984
Report#: 06200902
Our Order #: 128651

Specification: ASTM A36-05

Quantity: 500 PN 283025
Items: DOUBLE ARM SIMPLEX FOR 1 1/4 PIPE
: 3/8 F

***** CHEMICAL ANALYSIS*****

Heat # / ID #	C	Mn	P	S	Si	Cr	Ni	Mo	Cu
JW0910009001	.13	.73	.020	.030	.18	.13	.22	.06	.35
	V	Cb							
	.002	.001							

***** MECHANICAL PROPERTIES *****

Heat # / ID#	Tensile Strength	Yield Strength	% E.	% R.A.
JW0910009001	67200 PSI	46500 PSI	25.0	

HARDNESS:
MILL: NUCOR BAR MILL
DREF: 052109TS
NOTE: MELTED AND MANUFACTURED IN THE USA
: NO WELD REPAIR

The item listed above was processed in accordance with J.L.K. Industries Inc Quality Manual Rev C 2/94.

J.L.K. INDUSTRIES INC

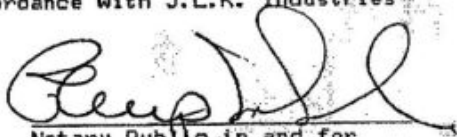
Notary Public in and for
Harris County, Texas

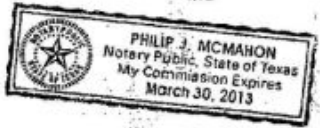

P.O. Box 40143
Houston, Texas 77240
Fax (713) 462-4715

14545 Sommermeyer
Houston, Texas 77041
(713) 462-7761

Figure A-12. Steel Arm Simplex Material Certification, Test Nos. BBC-1, BBC-3, and BBC-4

NUCOR
PLATE MILL

P.O. Box 279
Wintona, NC 27888
(252) 365-9700

Mill Test Report

Page 1

NUCOR
It's our Nature.™

Issuing Date : 01/21/2008 B/L No. : 158312 Lead No. : 191106 Our Order No. : 800737 Cust. Order No. : 2229
 Vehicle No: HOKL 729048
 Specification : 1.2880" x 96.000" x 240.000"
 ASTM A36-02/ASTM A709 Grade 50-57/ASME SA36-02a

Bold To : RANGER STEEL SERVICES LP
1226 NORTH LOOP W. STE 850
HOUSTON, TX 77009

Ship To : RANGER STEEL SUPPLY (RAIL)
SAND SPRINGS RAIL ROAD
1650 S. 51ST STREET
SAND SPRINGS, OK 74083

MECHANICAL

Heat No	C	Mn	P	S	Si	Cu	Ni	Cr	Mo	Alz	V	Nb	Ti	N	Cs	B	Sn	CEQ	PCM
8100575	0.17	0.82	0.014	0.003	0.20	0.16	0.06	0.08	0.02	0.023	0.002	0.001	0.001		0.0010	0.0001	0.007	0.34	0.23

Plate Serial No	Tensile Test					Charpy Impacts					
	Plates	Temp	Dir.	Yield (ksi)	Tensile (ksi)	Dir.	1 shear	2 shear	3 shear	4 shear	Min Ave.
8100575-03	7	28.58	T	42,100	70,400						
			T	44,000	67,700						

158312

RANGER STEEL
QUALITY APPROVED

Manufactured to fully killed fine grain practice by Electric Arc Furnace. Welding or weld repairs not performed on this material. Martensy has not been used in the direct manufacturing of this material. Produced as continuous cast as-rolled discrete plate. Yield by 0.5%EL method unless otherwise specified. Ceq = C+(Mn/6)+(Cr+Mo+V)/5+(Cu+Ni)/15
 Form = C+(S+Si)/3+(Mn+Cu)/2+(Nb+Ti)/2+(Al)/3
 Melled and manufactured in the USA. ISO 9001:2000 certified (#12443-0) by BRI Quality System Register (#0995-00). PED 97723.EC 7/2 Annex 1, Para. 4.3 Compliant. DIN 6049 3.1, EN 10204 3.1, DIN EN 10204 3.1(2006) compliant. For A36 grades only, Quality Assurance certificate No. 03-MS17CR-182

We hereby certify that the contents of this report are accurate and correct. All test results and operations performed by the material manufacturer are in compliance with the applicable specifications.

T. A. Depotis
T. A. Depotis, Metallurgist 01/22/2008 6:40:49 AM

162

Figure A-13. Steel Base Plate Material Certification, Test Nos. BBC-1, BBC-3, and BBC-4

December 22, 2010
MWRSF Report No. TRP-03-248-10



MATERIAL CERTIFICATION

VALMONT INDUSTRIES
HIGHWAY 275
PO BOX 358
VALLEY, NE 68064-0358

Part Number: 0301270
 Description: DOUBLE BOLT POLE
 Material Spec: ASTM A27-08 GR 65-35
 P.O. Number: 76315

<u>Pour Date</u>	<u>Heat Number</u>	<u>Quantity</u>	<u>Heat Code</u>
7/16/2009	7BH33	500	NA

CHEMICALS

C: 0.21	Mn: 0.97	Si: 0.50	Ni: 0.06
Cr: 0.12	Mo: 0.02	Al: 0.04	S: 0.01
P: 0.00	Cu: 0.08	V: 0.01	Ti: 0.034
Nb: 0.010	Co: 0.005	CE: 0.00	

PHYSICALS

Hardness (BHN):	174	Elongation (%):	30
Tensile Strength (psi):	81303	Reduction of Area (%):	49
Yield Strength (psi):	52412		

Remarks:

These castings were melted and manufactured in the USA by Eagle Alloy, Inc. (These castings meet a minimum 75,000 psi tensile and 45,000 psi yield strength).

ISO 9001-2000 Registered
 Certificate No. FM 69154

EA 9-0046
 T:\CitySec\RMIS\Spec\Cast\HT200.st



PED Annex 1 Section 4.3 Certified for
 ASTM A216, A351, A352
 SMA Certificate No. 512178

Bruce Gilbert

9/10/2009

Bruce Gilbert / Tom Leiter Date

Figure A-14. Steel Pole Simplex Material Certification, Test Nos. BBC-1, BBC-3, and BBC-4



Extrusion Department
58027 Charlotte Ave
Elkhart, IN 48517
Ph: (574) 295 6942

Certificate

Date: *August 10, 2009* Elkhart Internal Order No. 105665
Customer: *LEXINGTON* Customer Order No. 67115
Customer Part No. 26108008R
No. of lengths. 132
Alloy/Temper: 6063 - T4 Cast No. 809042
Part Desc. *Extruded Tube 26 ft 10 ins long x 8 ins dia x 0.25 ins wall. (Elkhart Part # ALZ2753)*

We hereby certify that the material shipped and covered by this document, has been inspected in accordance with the extruded tube dimensional requirements of "Aluminum standards and data 2000", as published by the Aluminum Association, and with other applicable requirements as stated on the customer order, and has been found to comply. The material meets the compositional limits for the alloy as indicated, and has been processed to comply with T4 temper requirements for the alloy.

Imperdy C...
Authorized Signature

Chemical Composition (Wt %):

	Si	Fe	Cu	Mn	Mg	Cr	Zn	Ti	Other Elements		
										Each Max	Total Max
Min	0.20				0.45						
Max	0.6	0.35	0.10	0.10	0.9	0.10	0.10	0.10	0.05	0.15	* Aluminum = Remainder

Actual cast analysis provided by billet vendor is retained on file.

Figure A-15. Aluminum Pole Material Certification, Test Nos. BBC-2 and BBC-5

VALMONT INDUSTRIES INC. STRUCTURES DIVISION FORM
914A

CERTIFIED TEST REPORT : A595 TAPERED TUBE(S) DATE : 12/1/2010
CUSTOMER ORDER NO : TEST VALMONT ORDER NO : 137123-1-1

VENDORS : NS-NATIONAL, US-USS, LT-LTV, GE-GENEVA, NU-NUCOR *WEATHERING ASTM A595
GRADE(S):A-MIN 55KSI, B-MIN 60 KSI, WEATHERING(A606/4) MIN 60 KSI THE
CHEMISTRY IS TRANSCRIBED FROM MILL REPORTS MAINTAINED IN VALMONT FILES

QTY	GA	DIAM	HEAT	VE	C	YIELD	TENSL	EL%	C	MN	P	S	SI	CU	CR	NI
						PSI	PSI									
1	7	10.00	1101611	SD	N	62600	74200	36	0.19	0.84	0.01	0.00	0.03			

SUBSCRIBED IN MY PRESENCE, SWORN TO, AND ACKNOWLEDGED BEFORE ME AT VALLEY, NEBRASKA,
THIS 1 DAY OF DECEMBER 2010 BY THE SUBSCRIBER WHO IS TO ME PERSONALLY KNOWN.

NOTARY PUBLIC: *Kim Mann-Davenport* *Launa Larsen*
LAUNA LARSEN
CERTIFICATION SPECIALIST
STRUCTURES DIVISION

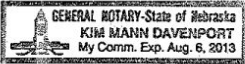

Figure A-17. Steel Pole Material Certification, Test No. BBC-6

SDI **Steel Dynamics®**
 Steel Dynamics Sales North America, Inc.
 Flat Roll Division
 4500 County Road 59
 Butler, IN 46721 USA
 Telephone (260) 868-8000
 Fax (260) 868-8955

CHEMICAL/PHYSICAL CERTIFICATION

S Valmont Industries(r
H I.C.P.D.
I Hwy 64
**P Valley, NE 68064
T United States
O Valley RECEIVING
 402-359-2201 EXT 385**

S Valmont Industries, INC
O 7002 N. 286th St.
L 358
D Valley, NE 68064-0358
T United States
O Cheryl Christenson
 Purchasing
 402-359-6037
 1-402-359-4481

Load ID
 1134870

Customer #	Part #	Po #	Order #	Line Item #	Coil #	Heat #	Coil Weight (lbs)
589	90044	D2365 - 4	222537	4	10B531348	11016110	41,830
Width (in)	Gauge (in)	Length(ft)	Material Specification		Product Description		
44.73 - mill edge	0.17 - Min	1,568	SAE 1021		Prime Hot Rolled Band		
<u>Chem Treat</u> : No		<u>Oiled</u> :					
Produced as ASTM A659 CS							

Ladle Chemical Analysis %

C	Mn	P	S	Si	Al	Cu	Ni	Cr	Mo	Sn	N	V	Nb	Ti	B	Ca	Pb
0.19	0.84	0.012	0.004	0.03	0.021	0.11	0.05	0.07	0.02	0.009	0.008	0.002	0.001	0.001	0.0000	0.001	0.00

Made in USA
 Shipped from Butler, IN, United States
 Melted, thin slab cast and rolled by proud Americans in Butler, IN.
 All tests were performed according to applicable standards and are correct as contained in the records of the company.
 Quality Assurance

Retrieved on : 05/03/10 13:59:45

Steel Dynamics, Inc. Rev. Level 5.2 [1003]

Page 2 of 4

167

Figure A-18. Steel Pole Material Certification, Test No. BBC-6

SDI **Steel Dynamics®**
 Steel Dynamics Sales North America, Inc.
 Flat Roll Division
 4500 County Road 59
 Butler, IN 46721 USA
 Telephone (260) 868-8000
 Fax (260) 868-8955

CHEMICAL/PHYSICAL CERTIFICATION

S
H
I
P
T
O

Valmont Industries(r
 I.C.P.D.
 Hwy 64
 Valley, NE 68064
 United States

Valley RECEIVING
 402-359-2201 EXT 385

S
O
L
D
T
O

Valmont Industries, INC
 7002 N. 288th St.
 358
 Valley, NE 68064-0358
 United States

Cheryl Christensen
 Purchasing
 402-359-6037
 1-402-359-4481

Customer #	Part #	Po #	Order #	Line Item #	Coil #	Heat #	Coil Weight (lbs)
589	4156156	PO1742 - 1	225625	1	10B547176	41022820	46,830

Width (In)	Gauge (In)	Length(ft)	Material Specification	Product Description
56.0	0.143 - Min	1,664	SAE 1015	Prime Hot Rolled Band

Chem Treat : No Oil Type :
 Produced as ASTM A659 CS

Ladle Chemical Analysis %

C	Mn	P	S	Si	Al	Cu	Ni	Cr	Mo	Sn	N	V	Nb	Ti	B	Ca	Pb
0.18	0.44	0.007	0.004	0.02	0.026	0.11	0.04	0.05	0.01	0.006	0.010	0.001	0.000	0.001	0.0000	0.002	0.00

Made in USA
 Melted, thin slab cast and rolled by proud Americans in Butler, IN.
 All tests were performed according to applicable standards and are correct as contained in the records of the company.
 Quality Assurance

Retrieve on

Steel Dynamics, Inc. Rev. Level 2.3 [602] - coil

Page 1 of 1

169

Figure A-20. Steel Arm Material Certification, Test No. BBC-6

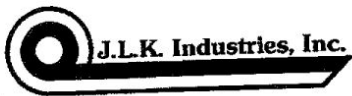

REPORT OF PHYSICAL AND CHEMICAL TESTS

Date: JULY 9, 2010
Customer: VALMONT INDUSTRIES INC
Customer PO#: 97186

Lot#: 55984
Report#: 08121023
Our Order #: 137893

Specification: ASTM A36-05
Quantity: 500 PN 283025
Items: DOUBLE ARM SIMPLEX FOR 1 1/4 PIPE
3/8 F

***** CHEMICAL ANALYSIS*****

Heat #/ ID #	C	Mn	P	S	Si	Cr	Ni	Mo	Cu
: JW0910009001	: .13	: .73	: .020	: .030	: .18	: .13	: .22	: .06	: .35
	: V	: Cb							
	: .002	: .001							

***** MECHANICAL PROPERTIES *****

Heat # / ID#	Tensile Strength	Yield Strength	% E.	% R.A.
: JW0910009001	: 67200 PSI	: 46500 PSI	: 25.0	:

HARDNESS:
MILL: NUCOR BAR MILL
DREF: 052109TS
NOTE: MELTED AND MANUFACTURED IN THE USA
NO WELD REPAIR

The item listed above was processed in accordance with J.L.K. Industries Inc Quality Manual Rev C 2/94.

Pauline Cooley
J.L.K. INDUSTRIES INC

Philip J. McMahon
Notary Public in and for
Harris County, Texas

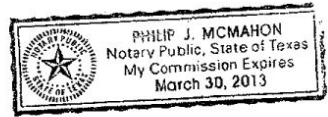

P.O. Box 40143
Houston, Texas 77240
Fax (713) 462-4715

14545 Sommermeyer
Houston, Texas 77041
(713) 462-7761

Figure A-22. Steel Arm Simplex Material Certification, Test No. BBC-6

EVRAZ CLAYMONT STEEL
DIVISION OF EVRAZ INC. NA

Material Test Report

B/L: 280990

4001 Philadelphia Pike, Claymont DE 19703

07/22/2010

Sold To: VALMONT INDUSTRIES, INC.

ATTENTION: LAURIE CLARK, P.O. BOX 358, VALLEY, NE 68064-0358

Order 217773-02 Customer PO U1181 Part No. 56765, S-56, RE

Specifications:
ASTM A572-00 GRADE 50 TYPE 2 with .15 - .40 Si / Valmont Spec S-56 Re v. 1, 2/6/07

Products Shipped for Order 217773-02 (sorted by Serial)

Serial	Heat-Slab Orig	R/R	Plate Size in Inches	Plate Size in MM	Lbs	Kg
A25614-1	2J960-403 USA	3.5	2.7500 x 60.0000 x 165.0000	69.85 x 1524.00 x 4191.00	7,721	3,474

Shipment Summary of Order 217773-02: 1 piece 7,721 lbs (3,474 kg)

Chemical Analysis for Order 217773-02 (sorted by Heat)

HeatAnlys	Heat	C	Mn	P	S	Si	Cu	Ni	Cr	Mo	Sn
	2J960	0.09	1.45	0.014	0.013	0.34	0.329	0.135	0.131	0.036	0.017
		Al	V	Nb/Cb	N	Alsol	Ti	B	CEQ		
		0.023	0.13	0.00	0.008	0.022	0.003	0.0004	0.48		

Tensile Tests for Order 217773-02 (sorted by Heat)

Serial	Heat-Slab	Gauge		Tensile		Yield		Elongation		RA	Head	Dir	Norm	S/R	Test ID
		Inches	MM	KSI	MPA	KSI	MPA	%	In.						
A24422-1	2J960-302	2.1250	53.98	76	523	52	361	32	2	50		Tran			275741
A24325-1	2J960-503	2.5000	63.50	75	518	56	383	29	2	50		Tran			275716

Impact Tests for Order 217773-02 (sorted by Heat)

Serial	Heat-Slab	Gauge		Temp		Ft-Lbs			Joules			Head	Dir	Norm	Stress	Rel	Test ID
		Inches	MM	°F	°C	1	2	3	1	2	3						
A24731-1	2J960-501	2.2500	57.15	-40	-40	93	92	75	126	125	102		Long				100519
A25610-1	2J960-301	3.7500	95.25	-20	-29	22	28	24	30	38	33		Long				100779

Impact Tests for Order 217773-02 Supplemental Information (sorted by Heat)

Serial	Heat-Slab	Gauge		Mil Lat Exp			Shear %			Size	Loc	Head	Dir	Norm	Stress	Rel	Test ID
		Inches	MM	1	2	3	1	2	3								
A24731-1	2J960-501	2.2500	57.15							Full	Std		Long				100519
A25610-1	2J960-301	3.7500	95.25							Full	Std		Long				100779

Other Information for Order 217773-02

Material is 100% melted and manufactured in the USA.

Order 217883-02 Customer PO 96623 Part No. 53158, S-127, R

Specifications:
ASTM A36/A36M-08 / ASME SA36/SA36M 2007 Edition Fine Grain Fully Killed Steel; Valmont Spec. S-127 Rev. 5, 7/14/08

Products Shipped for Order 217883-02 (sorted by Serial)

Serial	Heat-Slab Orig	R/R	Plate Size in Inches	Plate Size in MM	Lbs	Kg
A26915-1	2K071-402 USA	7.8	1.2500 x 96.0000 x 120.0000	31.75 x 2438.40 x 3048.00	4,084	1,838

Shipment Summary of Order 217883-02: 1 piece 4,084 lbs (1,838 kg)

Chemical Analysis for Order 217883-02 (sorted by Heat)

HeatAnlys	Heat	C	Mn	P	S	Si	Cu	Ni	Cr	Mo	Sn
	2K071	0.08	0.86	0.017	0.015	0.21	0.347	0.178	0.171	0.045	0.021
		Al	V	Nb/Cb	N	Alsol	Ti	B	CEQ		
		0.030	0.01	0.00	0.009	0.030	0.002	0.0000	0.34		

Valmont Industries Inc
Valley, NE
QC Inspected
VL 102391

AUG 10 2010
Notary Public

Unless otherwise specified, Mercury, radium or alpha source materials have not been used.

I certify the above results to be correct as contained in the records of the corporation.

Chief Metallurgist, David J. Cernava *D. J. Cernava*

Revision:

Page 1 of 4

Figure A-23. Steel Base Plate Material Certification, Test No. BBC-6



September 28, 2010

Valmont Farmington
Attn: Laura Hess
20805 Eaton Ave
Farmington, MN 55024

Subject: Aluminum Lighting Standard Certification
Farmington Purchase Order No.: 71311
Valmont Indiana Order No: 132756-1-1

In accordance with the contract, the products provided by Valmont comply with the following requirements:

1. Materials used were of appropriate alloy 356-T6 or B108-T6 (base) and 6063-T6 (shaft).
2. Welding was in accordance to A.W.S.D1.2 code. Welder, welder qualifications, and welding procedure records are on file.
3. Inspections of weldments were made by an A.W.S. certified weld inspector, certified associate welding inspector, and/or personnel working under a certified weld inspector.
4. Materials were purchased to T-4 specifications and heat-treated to T-6.

I certify that the reports are a true and correct copy as contained in the records of the company, and are available upon request.

Respectfully,

VALMONT INDUSTRIES, INC.

Franco Garcia
Production Manager
Structures Division

Subscribed in my presence, sworn to and acknowledged before me in Elkhart, Indiana, this 28th day of September 2010 by the subscriber who is to me personally known.

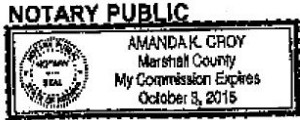

Engineered Support Structures Division, Valmont Industries, Inc.
58027 Charlotte Avenue Elkhart, Indiana 46517 USA
574-295-6942 Fax 574-295-6998 valmont.com

Figure A-24. Aluminum Pole Material Certification, Test No. BBC-7



Certificate of Conformance

Certificate# 250127-2

Date: 2/5/2010

Address: 2610 Ross Ave
 Schofield, WI 54478
 Phone: 555-555-0100
 Fax: 556-555-0111

Ship To:
 Valmont Structures
 20805 Eaton Ave.
 Farmington MN 55024-7932

Date Shipped: 2/5/10
 Packer# Number: 250127
 Purchase Order: 68898
 Job # 244501-2-1
 Alloy: 6063
 Temper: T1
 Extruded Date: 2/3/10

Part#	Dic#	Description	Aluminum Association Industry Standards			Quantity	Cast#
			Chemical Analysis				
			Alloy	6061	6063	6005	
09054004R	1617	Val Tube					113 29564
			Si	0.40 - 0.80	0.20 - 0.60	0.05 - 0.50	
			Fe	0.70	0.35	0.35	
			Cu	0.15 - 0.40	0.10	0.10	
			Mn	0.15	0.10	0.10	
			Mg	0.80 - 1.20	0.45 - 0.90	0.40 - 0.60	
			Cr	0.04 - 0.35	0.10	0.10	
			Zn	0.25	0.10	0.10	
			Ti	0.15	0.10	0.10	
			Others each	0.05	0.05	0.05	
			Total	0.15	0.15	0.15	
			Al	Rest	Rest	Rest	

Note: All of Crystal Finishing Systems extrusion processes are certified to the ASTM B221 standard. Periodic audits are completed and testing is performed by Anderson Laboratories

We Hereby certify to the best of our knowledge and belief the foregoing data.

Eric Zebro
 Authorized Signature

Figure A-25. Aluminum Pole Material Certification, Test No. BBC-7

CRYSTAL

FINISHING SYSTEMS, INC.

Certificate Of Conformance

Certificate# 268097-1
 Date: 6/9/2010

Address:
 2610 Ross Avenue
 Schofield WI 54476
 Phone: (715)-355-5351
 Fax (715)-355-8812

Ship To:
 Valmont Structures
 20805 Eaton Ave.

 Farmington MN 55024-7932

Part Number	Die Nbr	Description	Ship Qty	Date Shipped
17003504R	1615	VALMONT 204" [17-0"}X3.5X.125 RD TUBE 204" (16 6063-NO AGE	45.00	09-Jun-2010

Extrusion Info:		
<u>Cast</u>	<u>Alloy</u>	<u>Date Extruded</u>
30652	6063	Tuesday, June 8, 2010

Alloy	Si	Fe	Cu	Mn	Mg	Cr	Zn	Ti	Others Each	Total	Al
6061	0.40 - 0.80	.70	0.15 - 0.40	0.15	0.80 - 1.20	0.04 - 0.35	0.25	0.25	0.05	0.15	Rest
6063	0.40 - 0.80	.35	0.10	0.10	0.45 - 0.90	0.10	0.10	0.10	0.05	0.15	Rest
6005	0.40 - 0.80	.35	0.10	0.10	0.40 - 0.60	0.10	0.10	0.10	0.05	0.15	Rest

Note: All of Crystal Finishing Systems extrusion processes are certified to the ASTM B221 standard. Periodic audits are completed and testing is performed by Anderson Laboratories

We Hereby certify to the best of our knowledge and belief the foregoing data



 Authorized Signature

Figure A-26. Aluminum Arms Material Certification, Test No. BBC-7

Appendix B. Accelerometer Data Plots, Test No. BBC-1

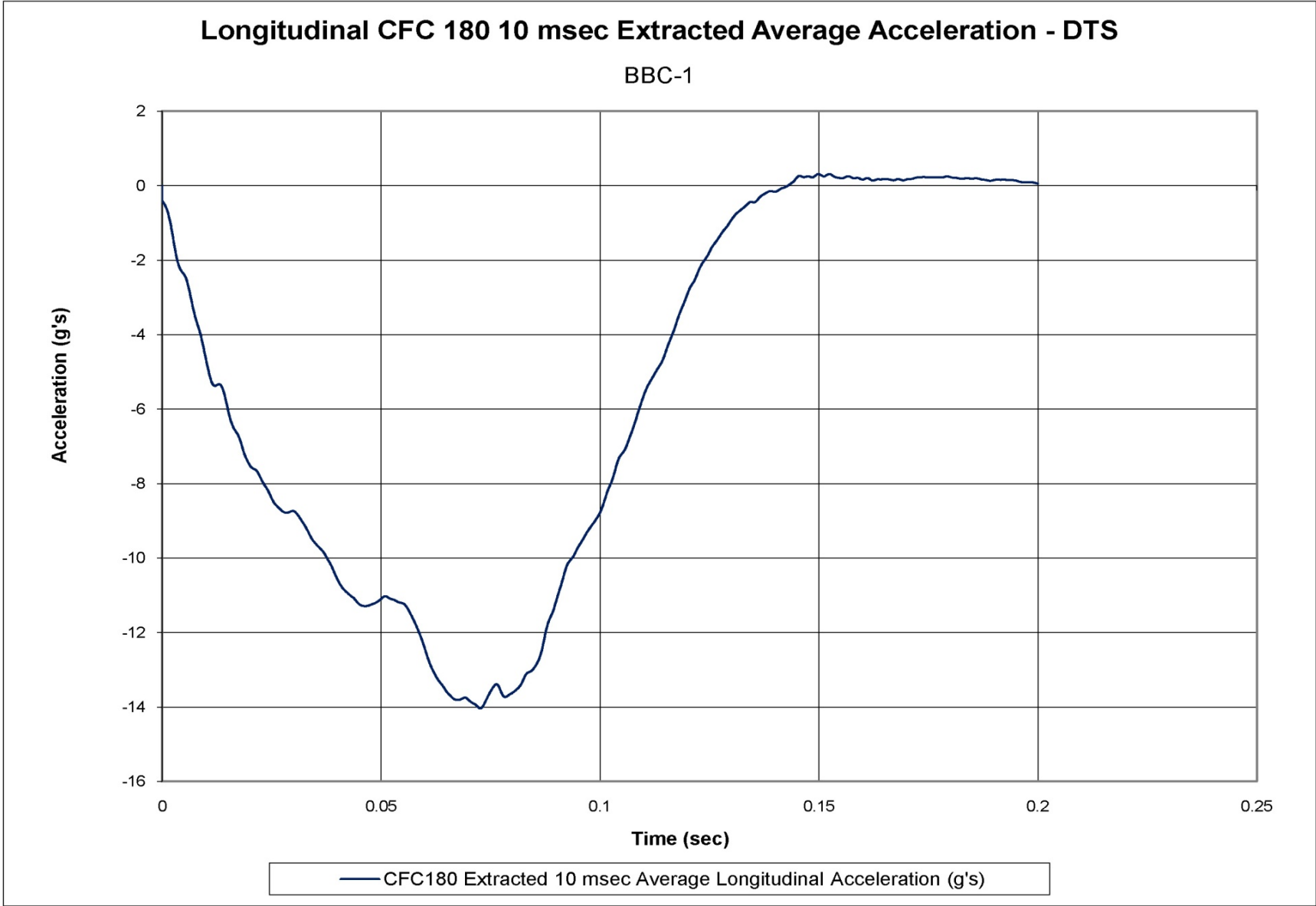

Figure B-1. Longitudinal Deceleration (DTS-BR39H), Test No. BBC-1

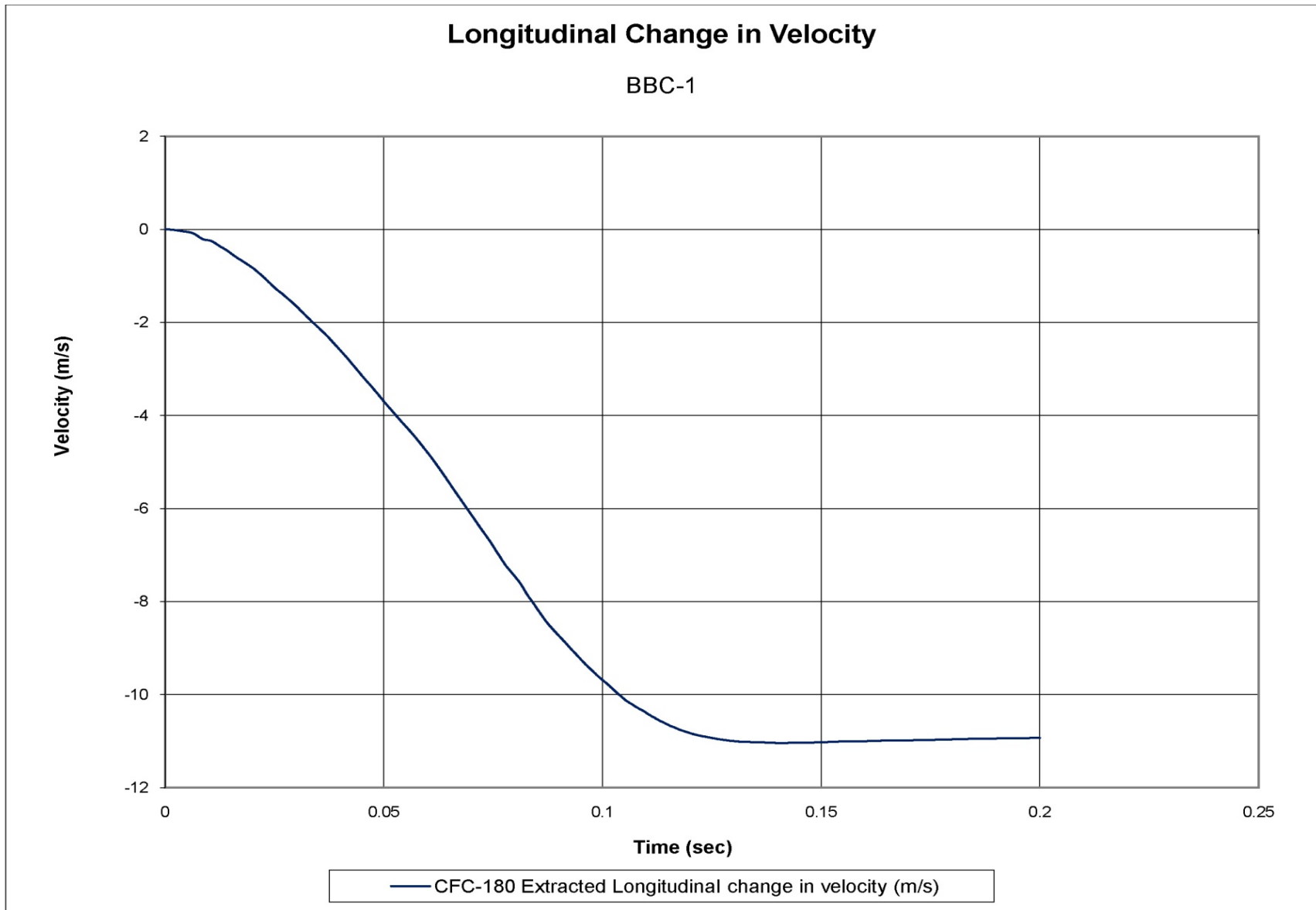

Figure B-2. Longitudinal Change in Velocity (DTS-BR39H), Test No. BBC-1

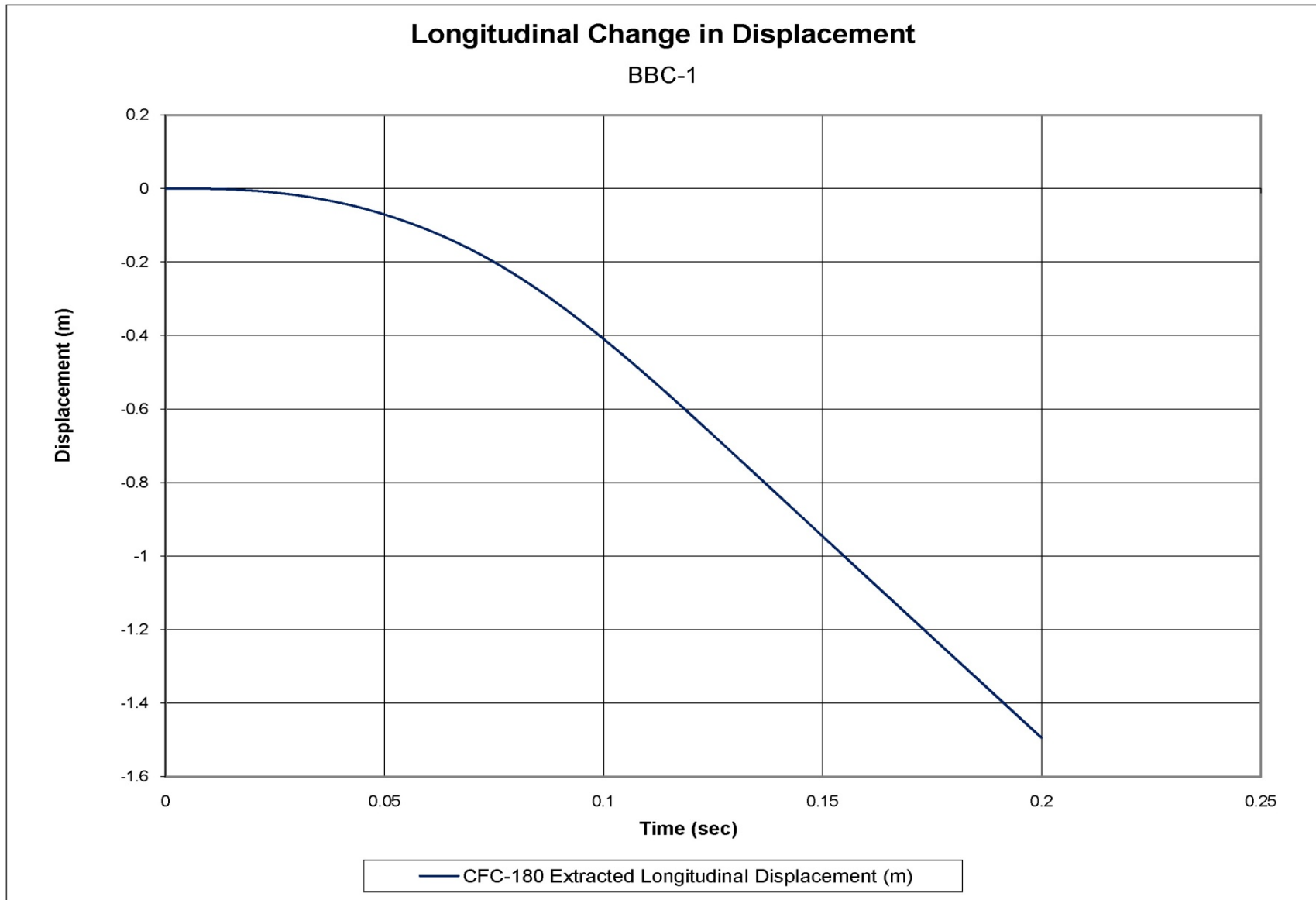

Figure B-3. Longitudinal Change in Displacement (DTS-BR39H), Test No. BBC-1

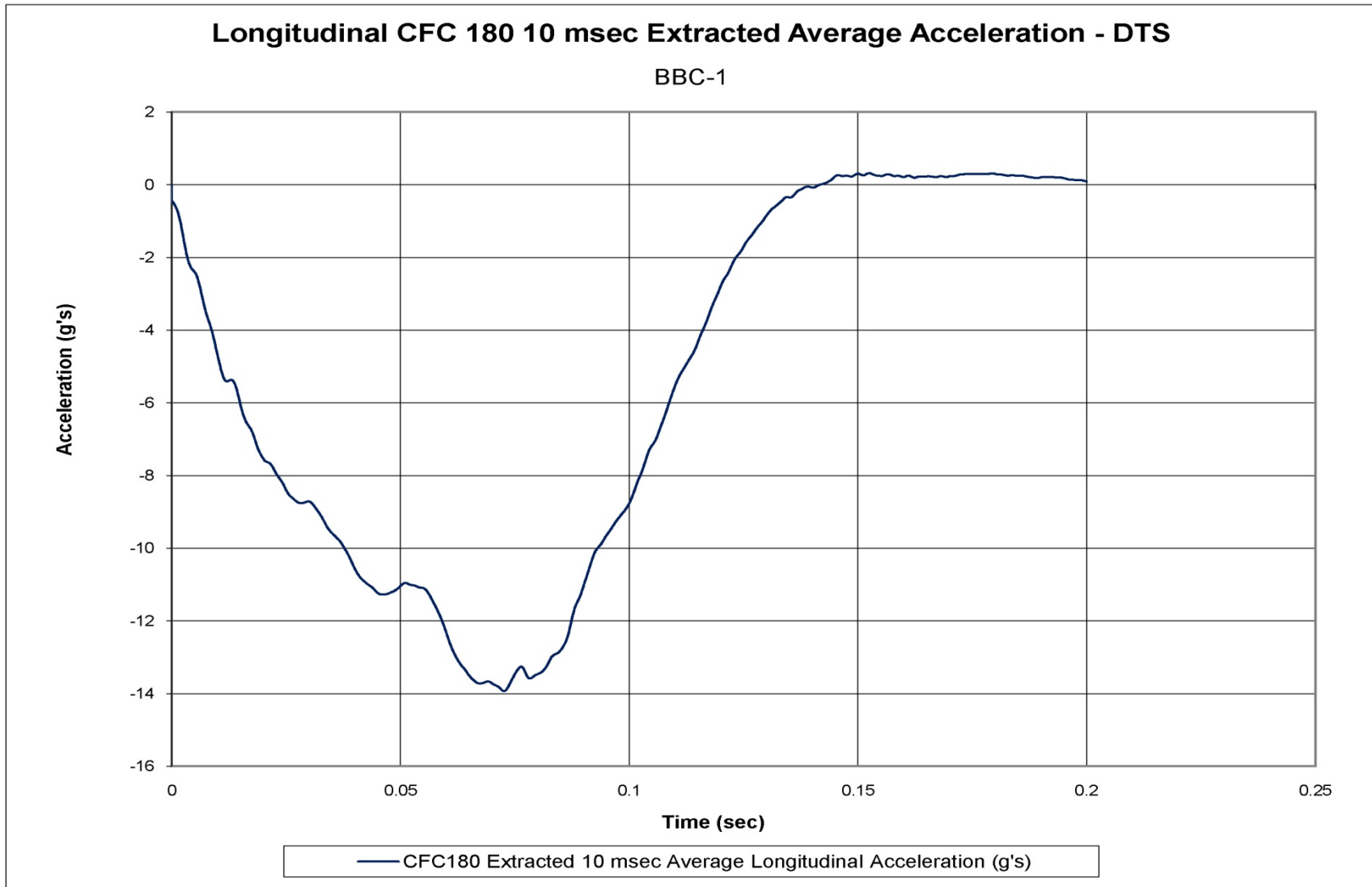

Figure B-4. Longitudinal Deceleration (DTS-CM54H), Test No. BBC-1

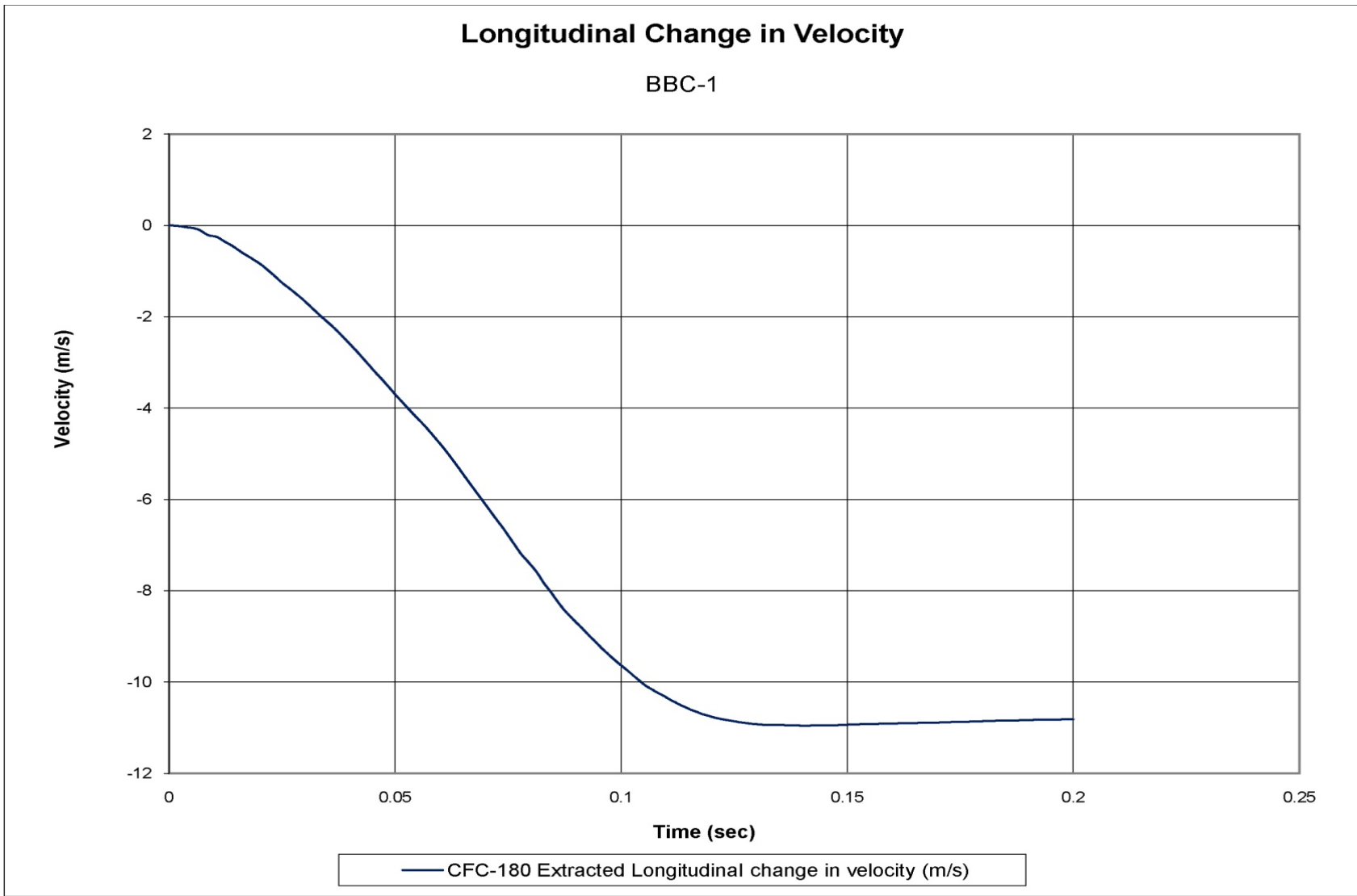

Figure B-5. Longitudinal Change in Velocity (DTS-CM54H), Test No. BBC-1

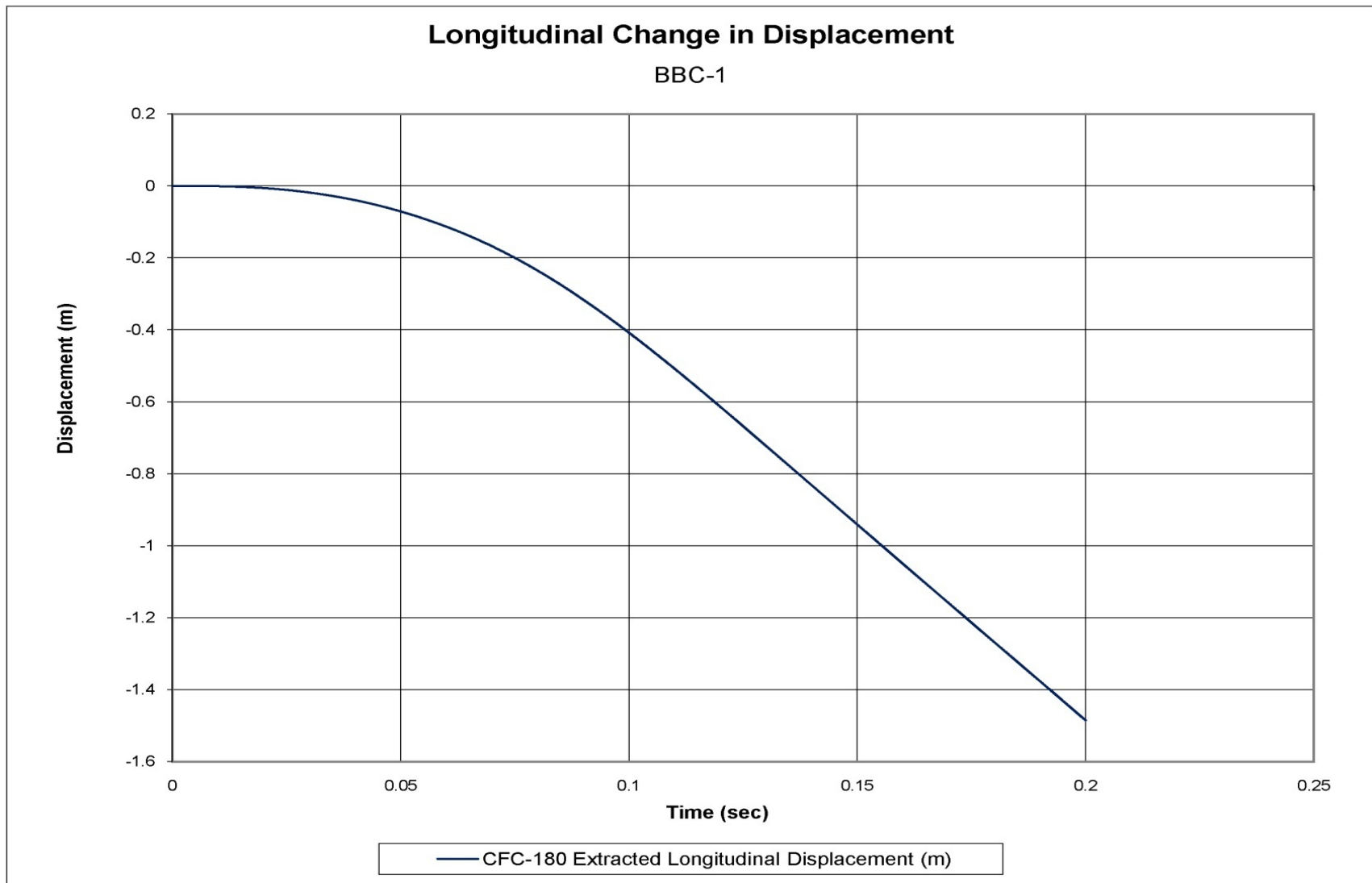

Figure B-6. Longitudinal Change in Displacement (DTS-CM54H), Test No. BBC-1

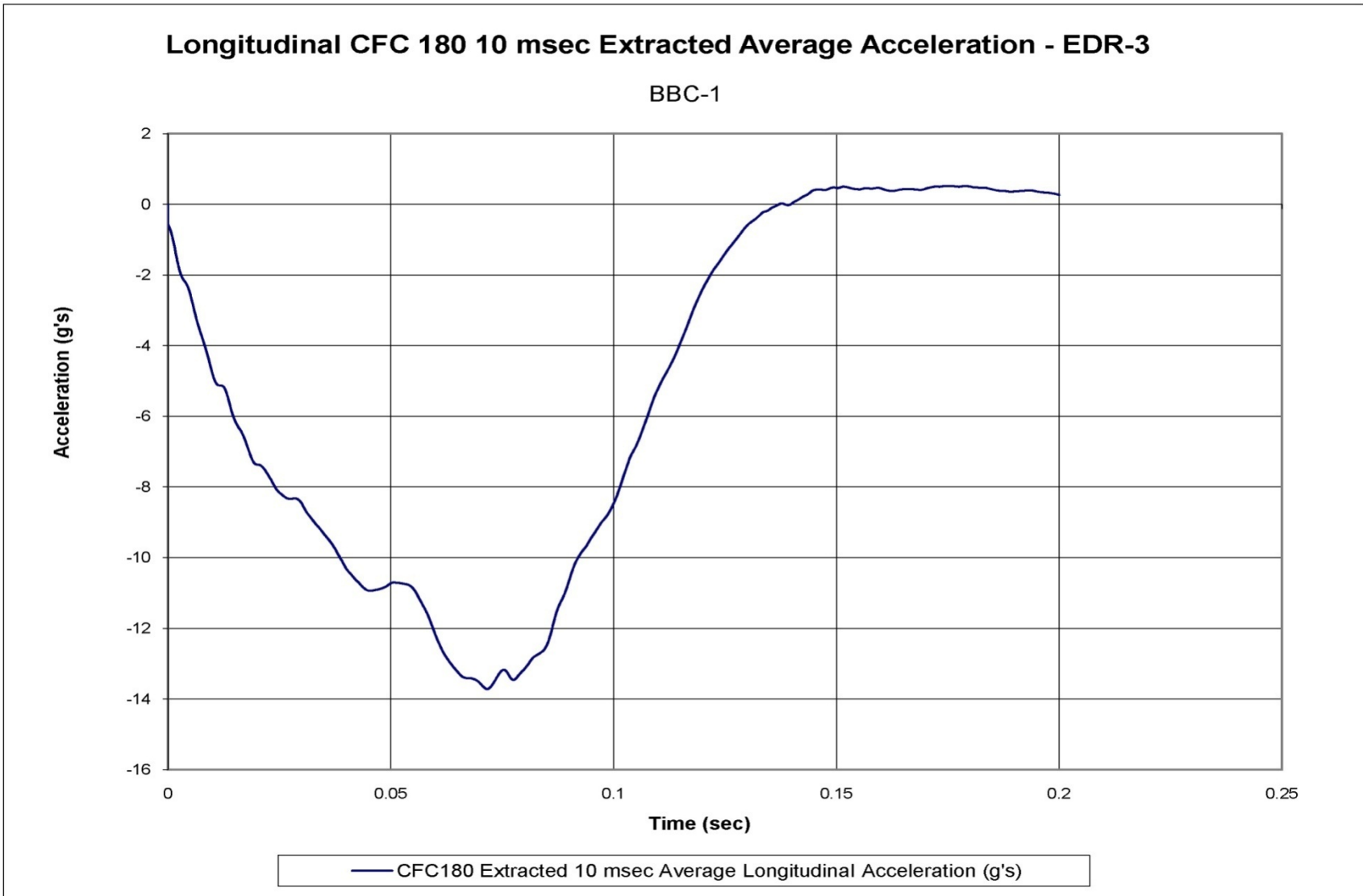

Figure B-7. Longitudinal Deceleration (EDR-3), Test No. BBC-1

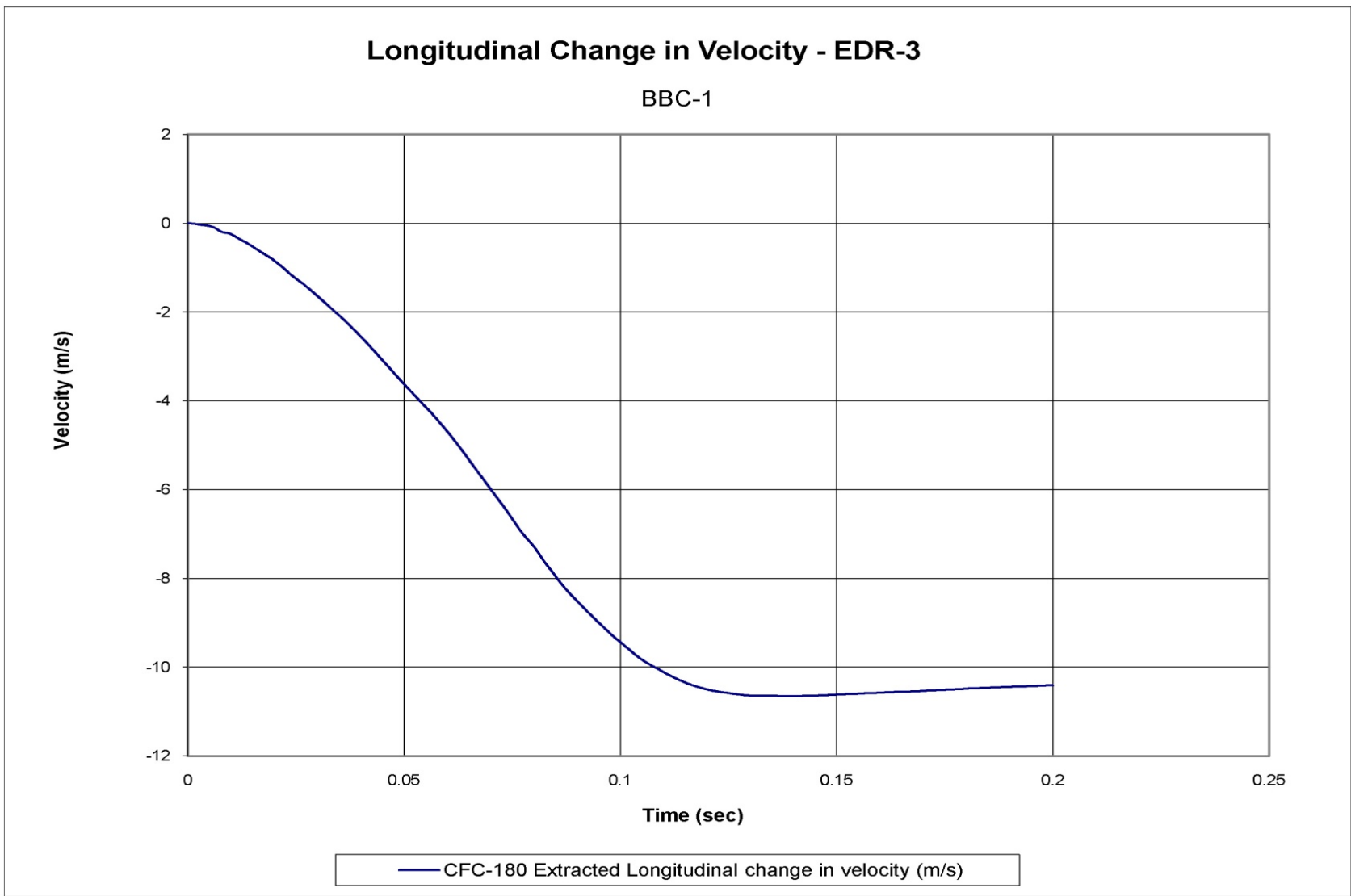

Figure B-8. Longitudinal Change in Velocity (EDR-3), Test No. BBC-1

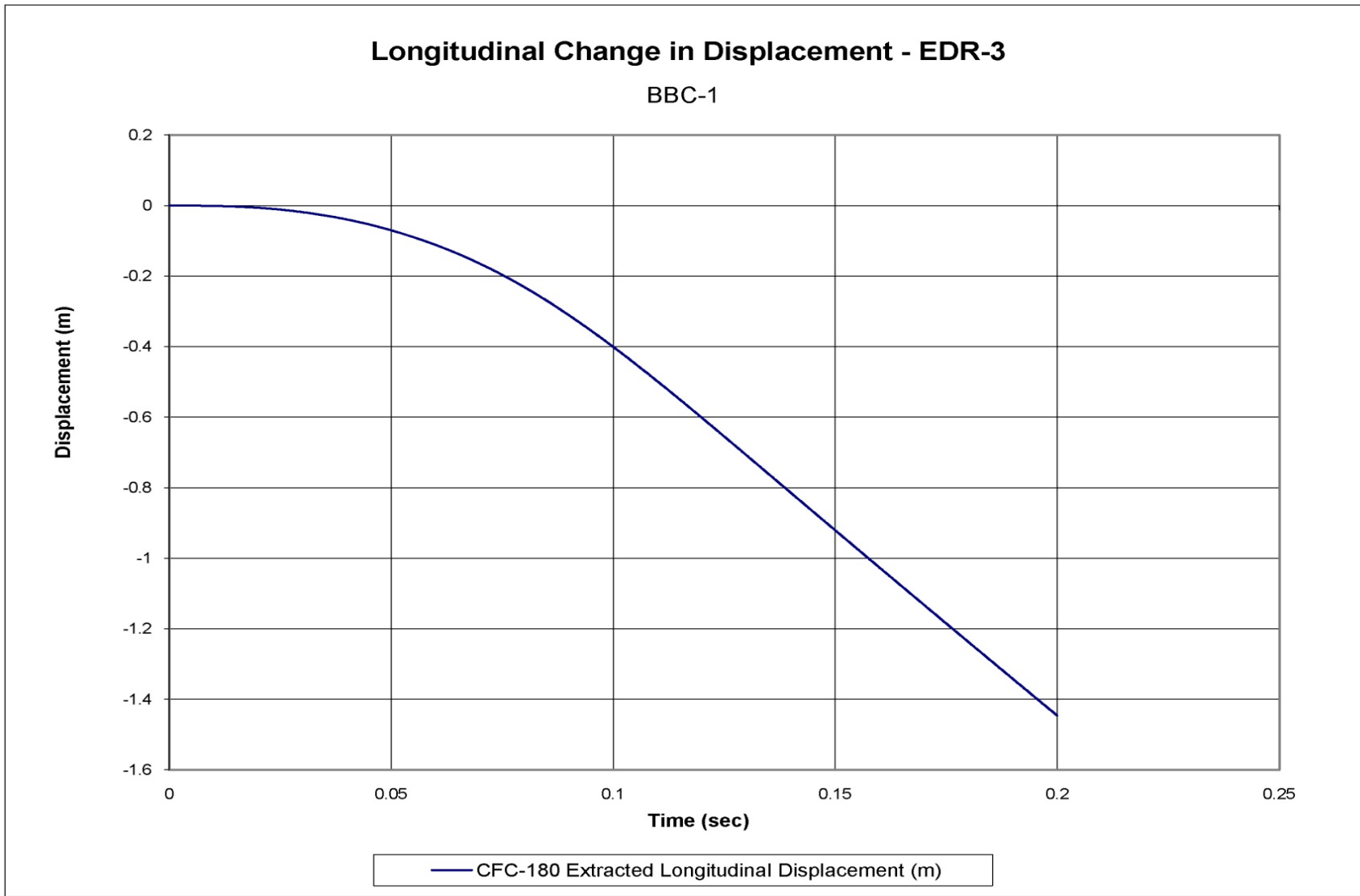

Figure B-9. Longitudinal Change in Displacement (EDR-3), Test No. BBC-1

Appendix C. Accelerometer Data Plots, Test No. BBC-2

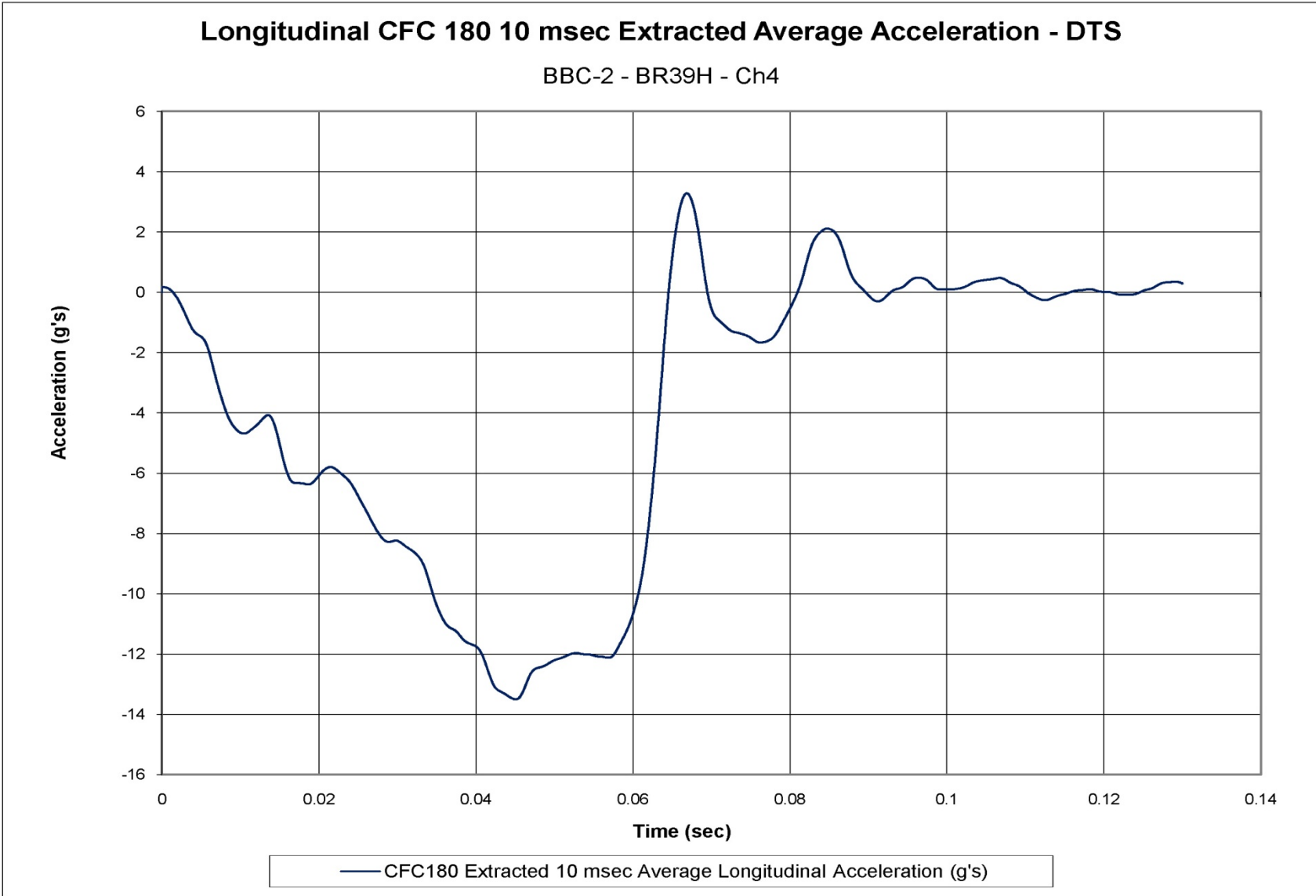

Figure C-1. Longitudinal Deceleration (DTS-BR39H), Test No. BBC-2

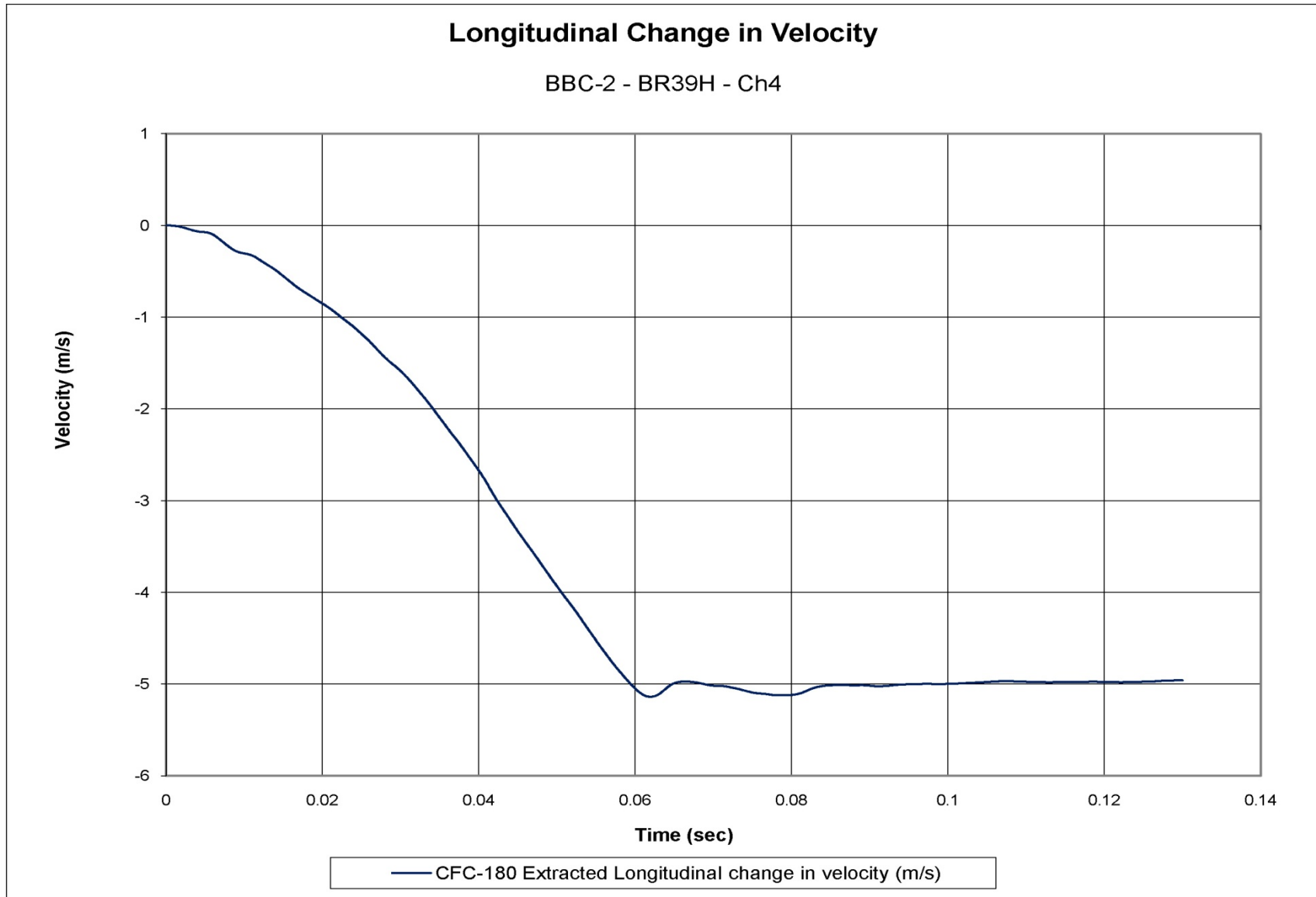

Figure C-2. Longitudinal Change in Velocity (DTS-BR39H), Test No. BBC-2

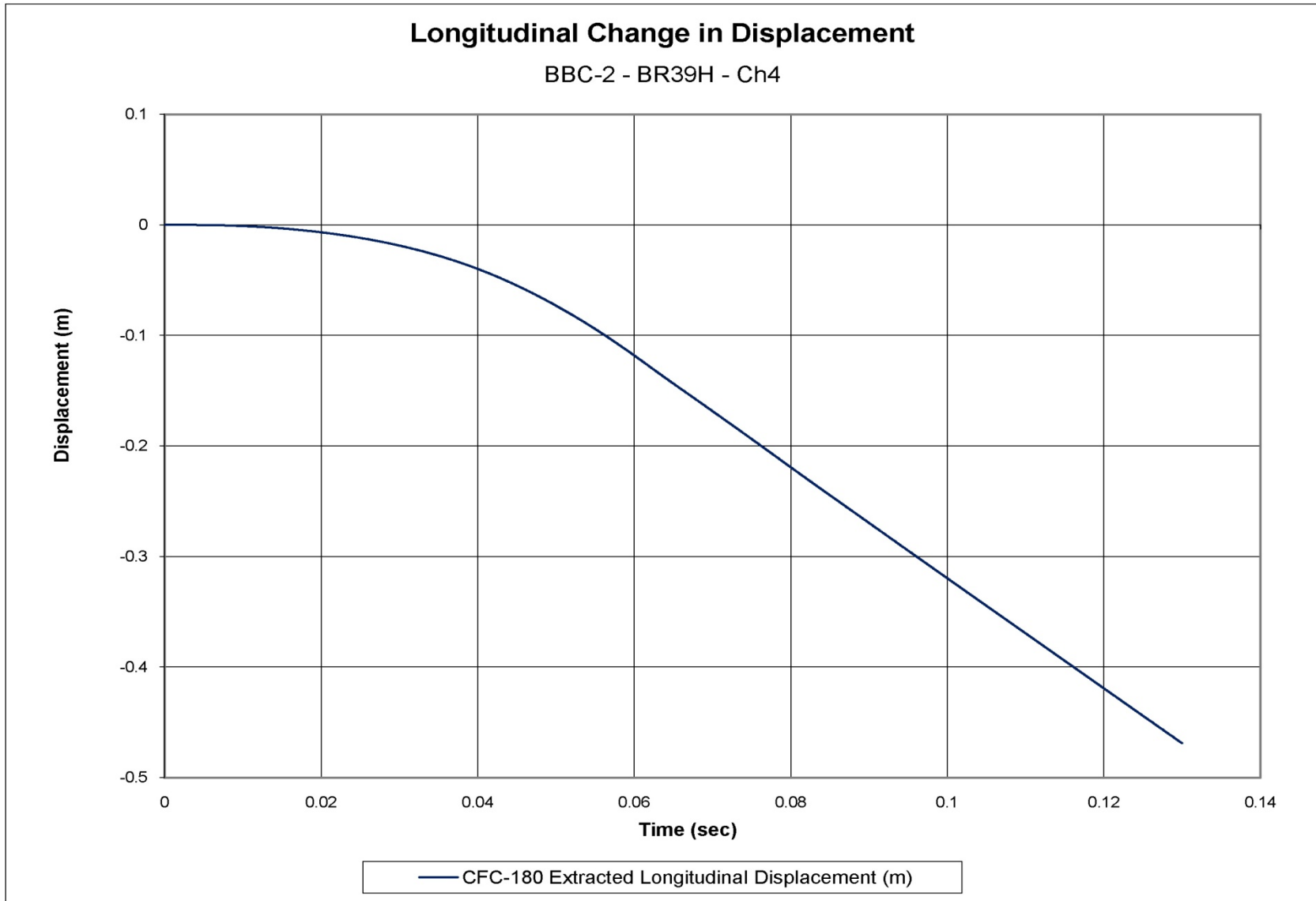

Figure C-3. Longitudinal Change in Displacement (DTS-BR39H), Test No. BBC-2

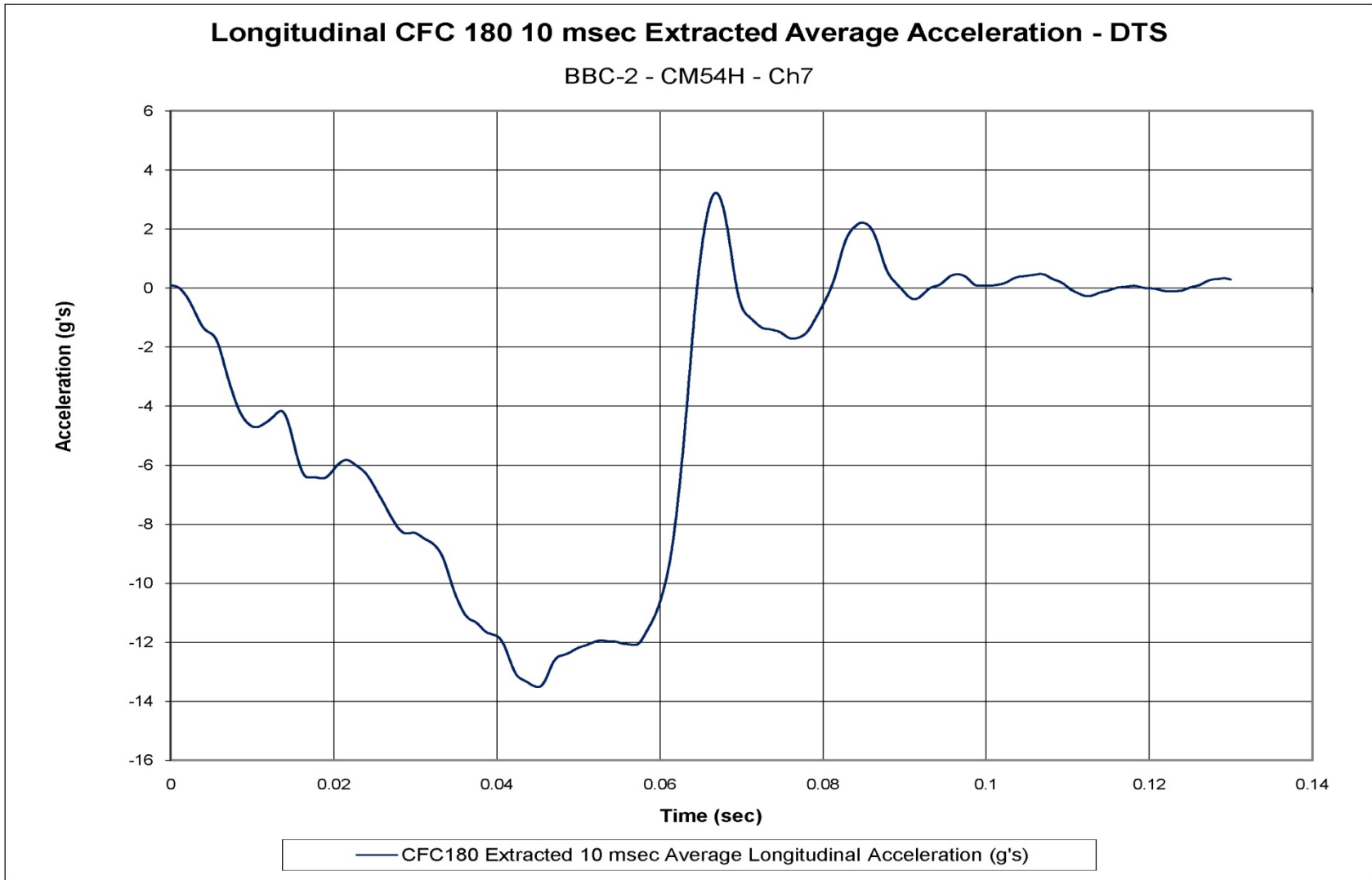

Figure C-4. Longitudinal Deceleration (DTS-CM54H), Test No. BBC-2

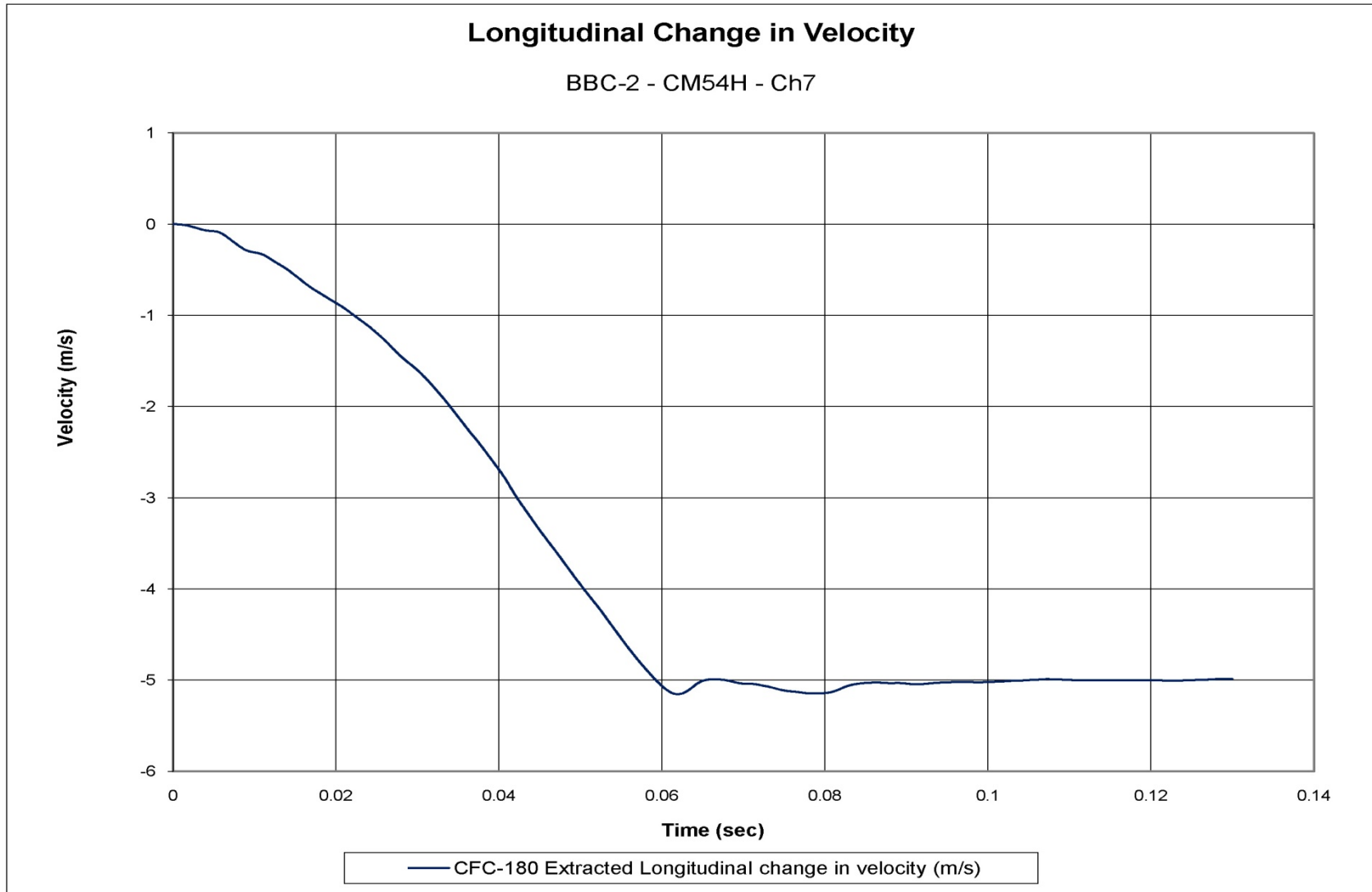

Figure C-5. Longitudinal Change in Velocity (DTS-CM54H), Test No. BBC-2

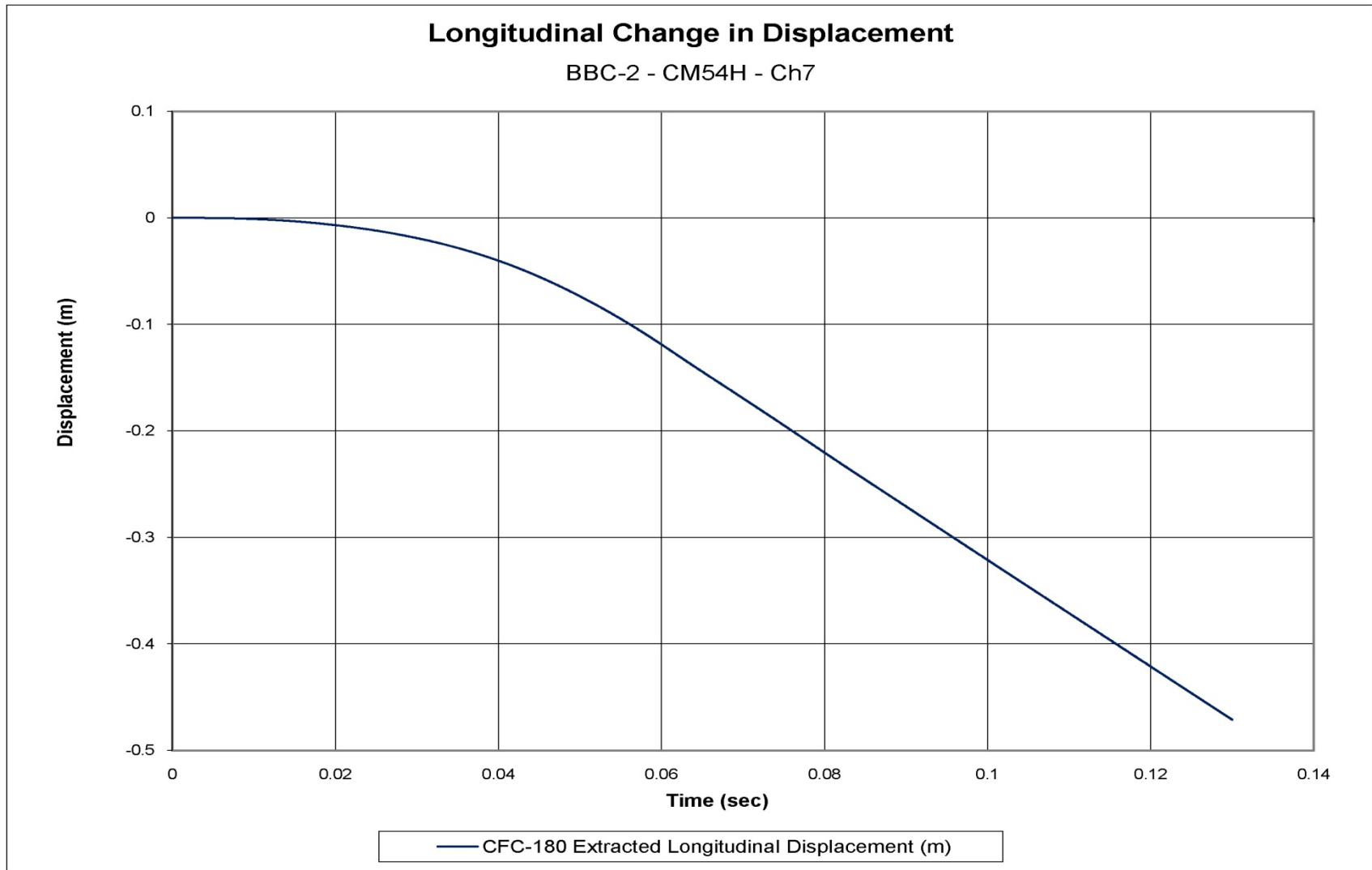

Figure C-6. Longitudinal Change in Displacement (DTS-CM54H), Test No. BBC-2

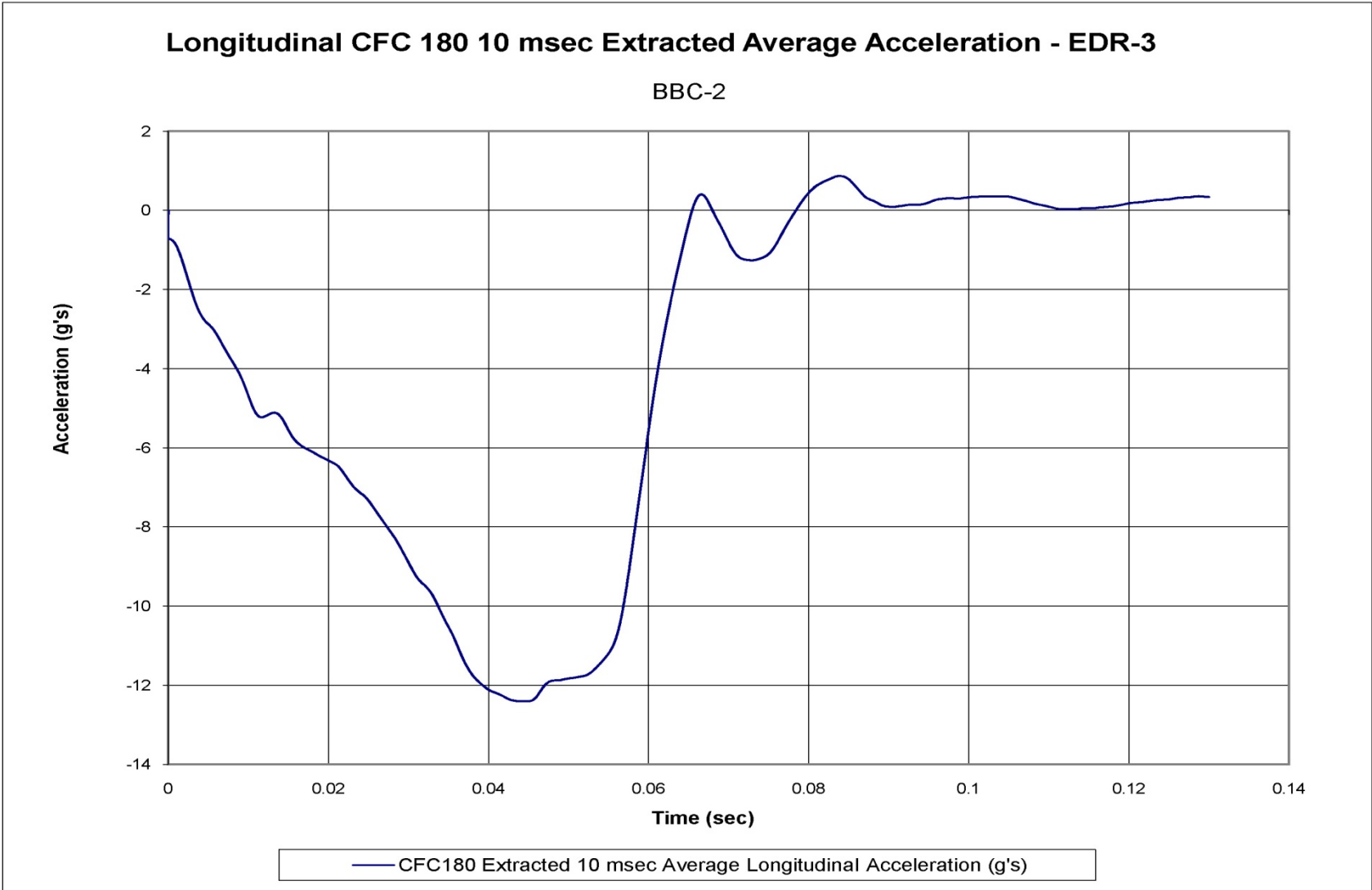

Figure C-7. Longitudinal Deceleration (EDR-3), Test No. BBC-2

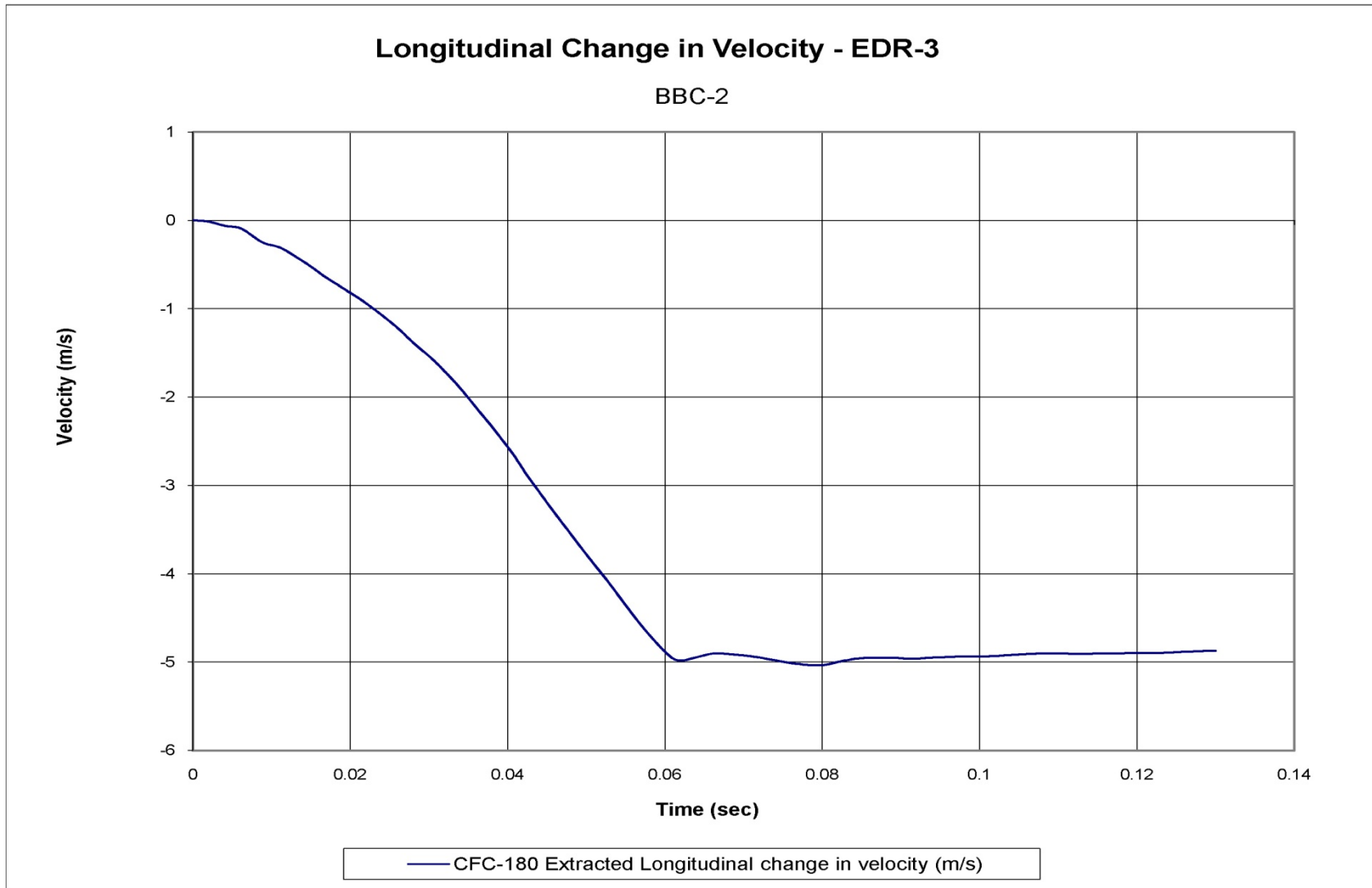

Figure C-8. Longitudinal Change in Velocity (EDR-3), Test No. BBC-2

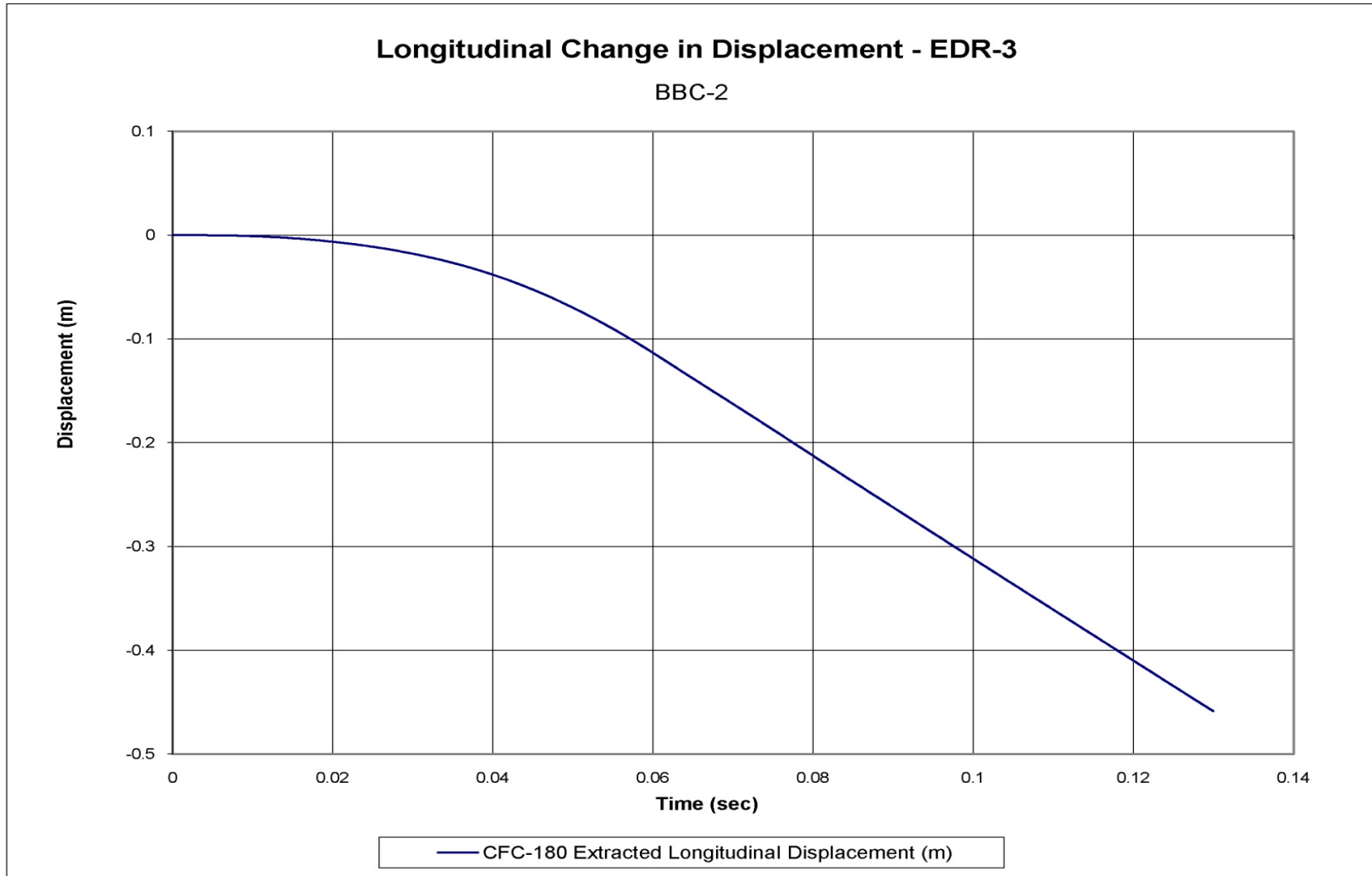

Figure C-9. Longitudinal Change in Displacement (EDR-3), Test No. BBC-2

Appendix D. Accelerometer Data Plots, Test No. BBC-3

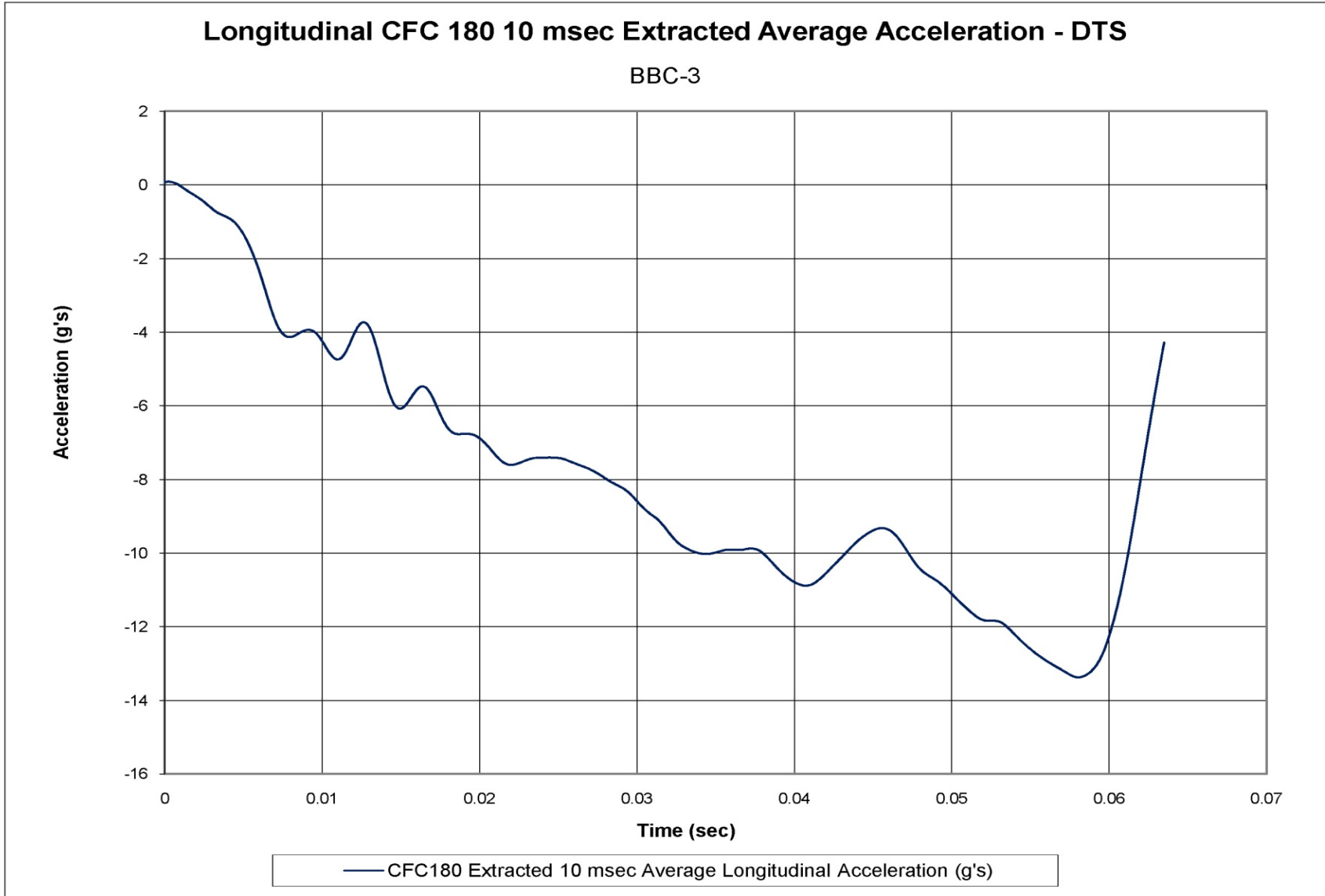

Figure D-1. Longitudinal Deceleration (DTS-BF57H), Test No. BBC-3

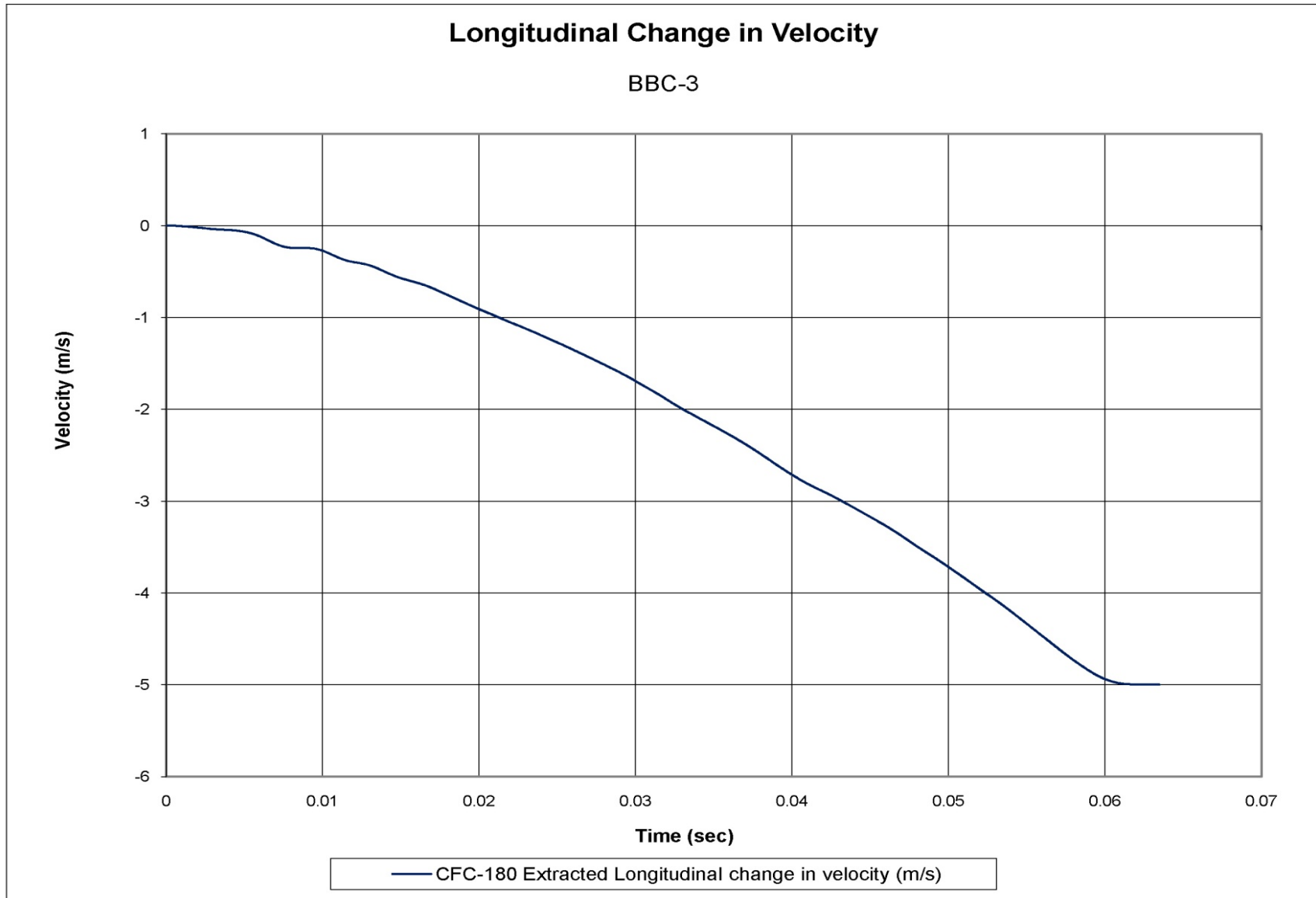

Figure D-2. Longitudinal Change in Velocity (DTS-BF57H), Test No. BBC-3

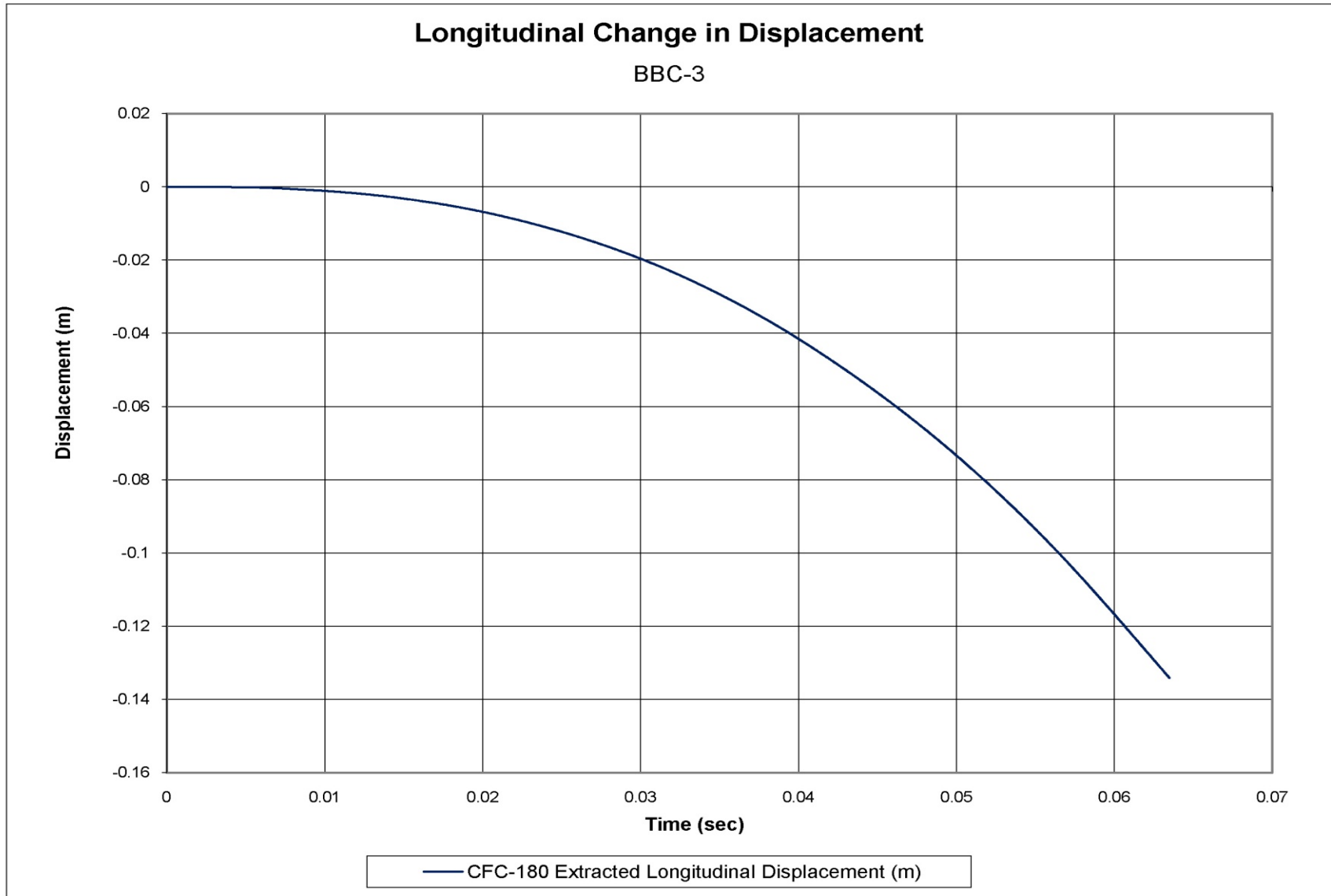

Figure D-3. Longitudinal Change in Displacement (DTS-BF57H), Test No. BBC-3

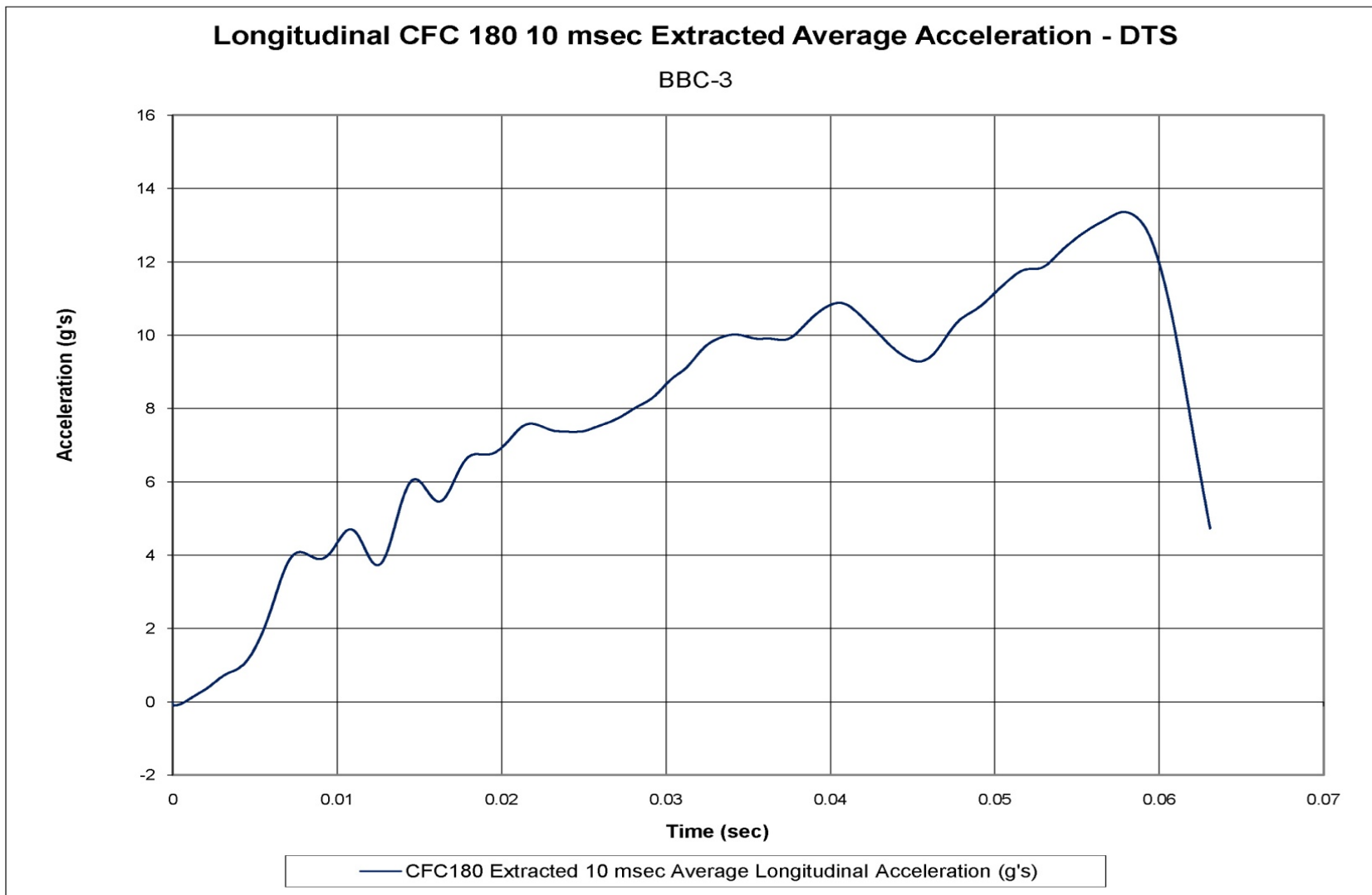

Figure D-4. Longitudinal Deceleration (DTS-CM54H), Test No. BBC-3

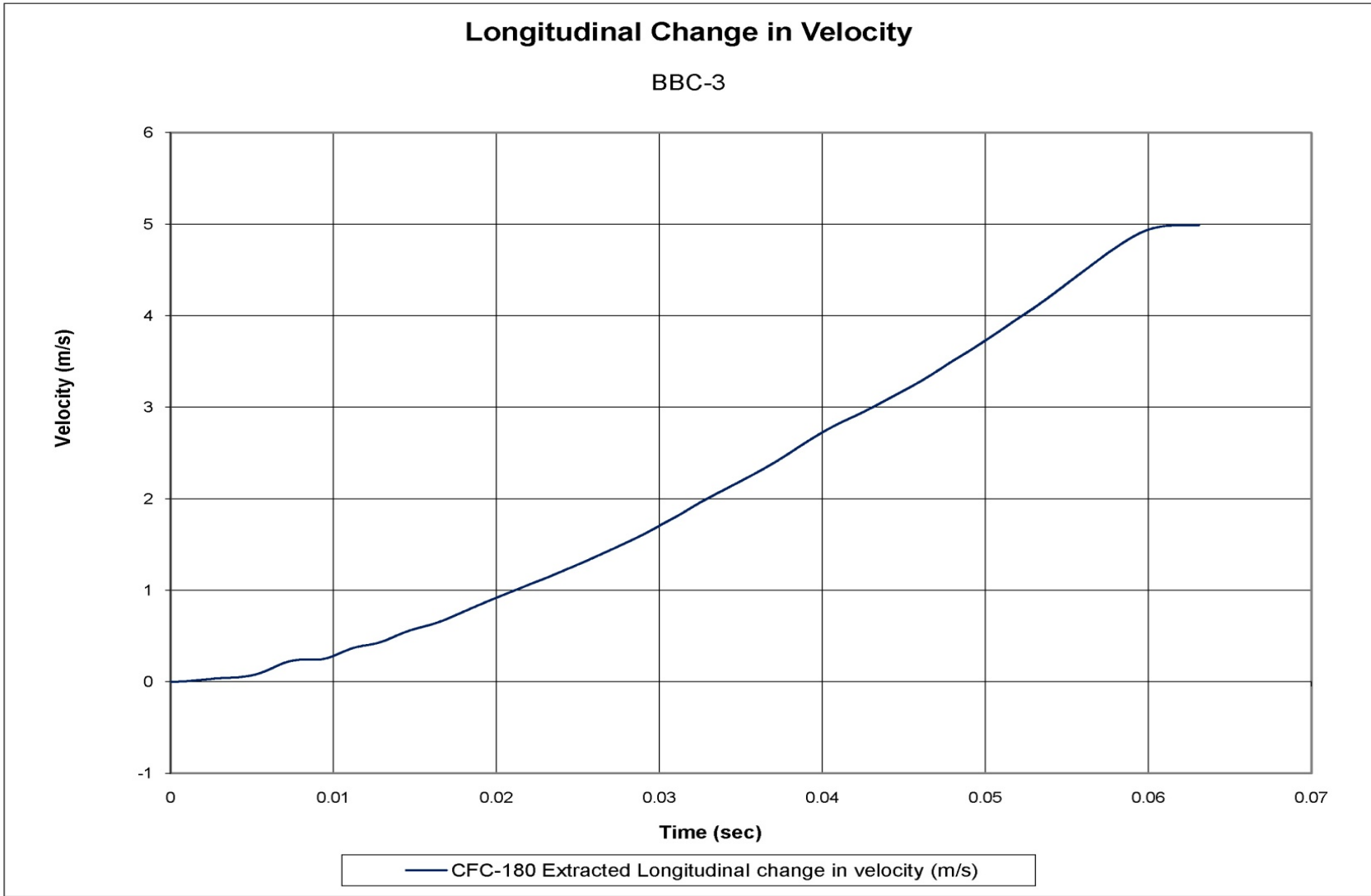

Figure D-5. Longitudinal Change in Velocity (DTS-CM54H), Test No. BBC-3

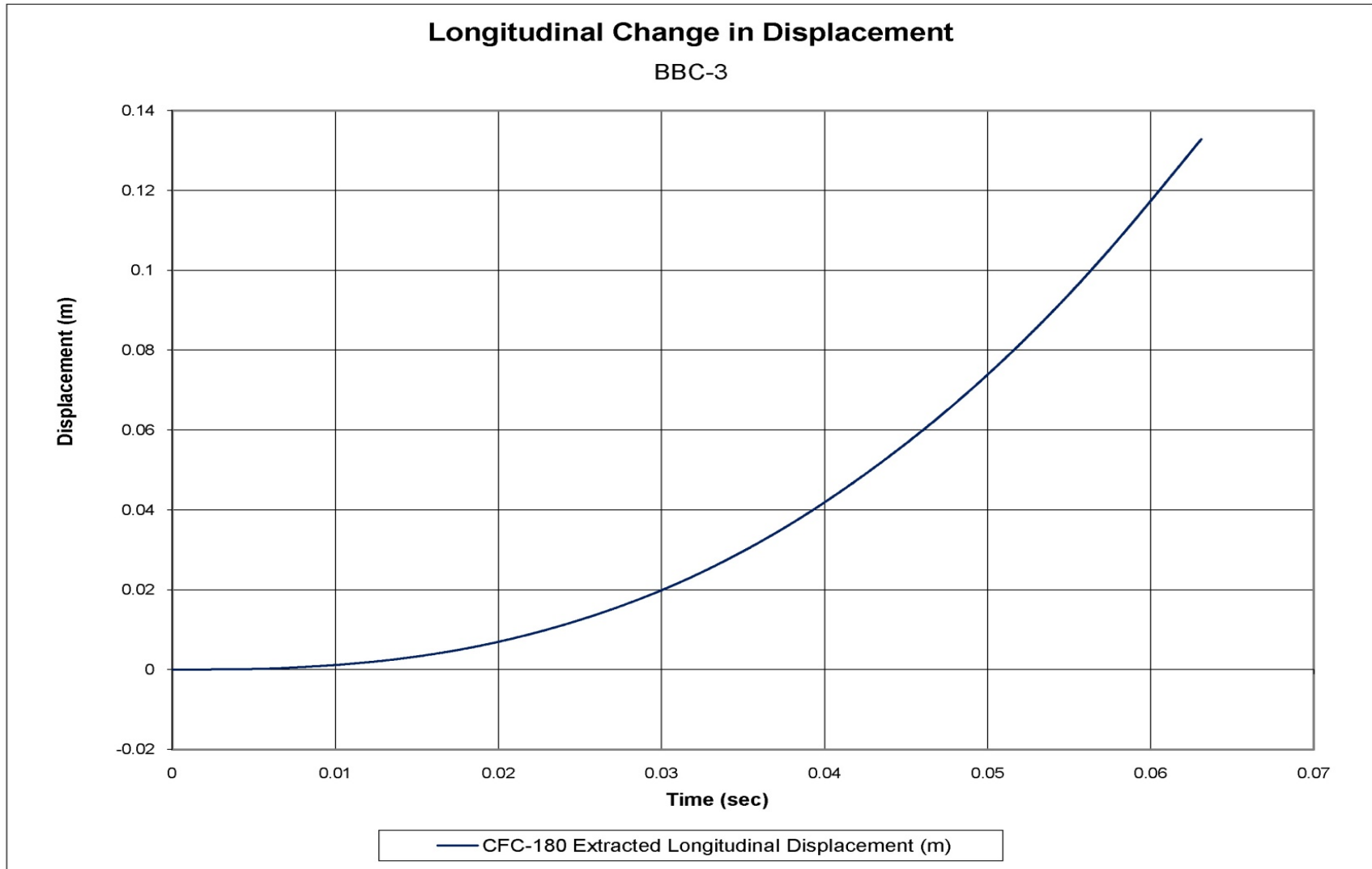

Figure D-6. Longitudinal Change in Displacement (DTS-CM54H), Test No. BBC-3

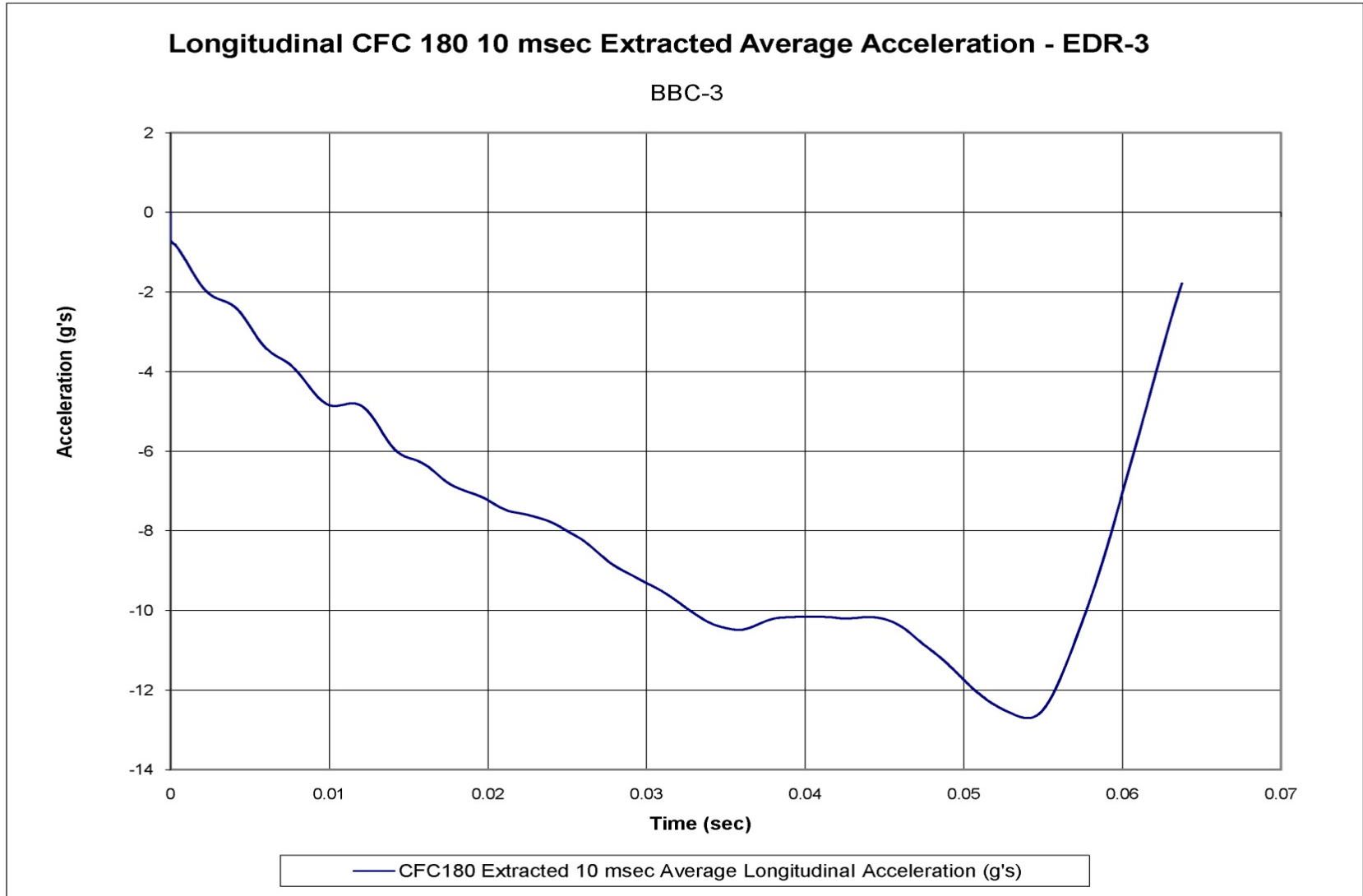

Figure D-7. Longitudinal Deceleration (EDR-3), Test No. BBC-3

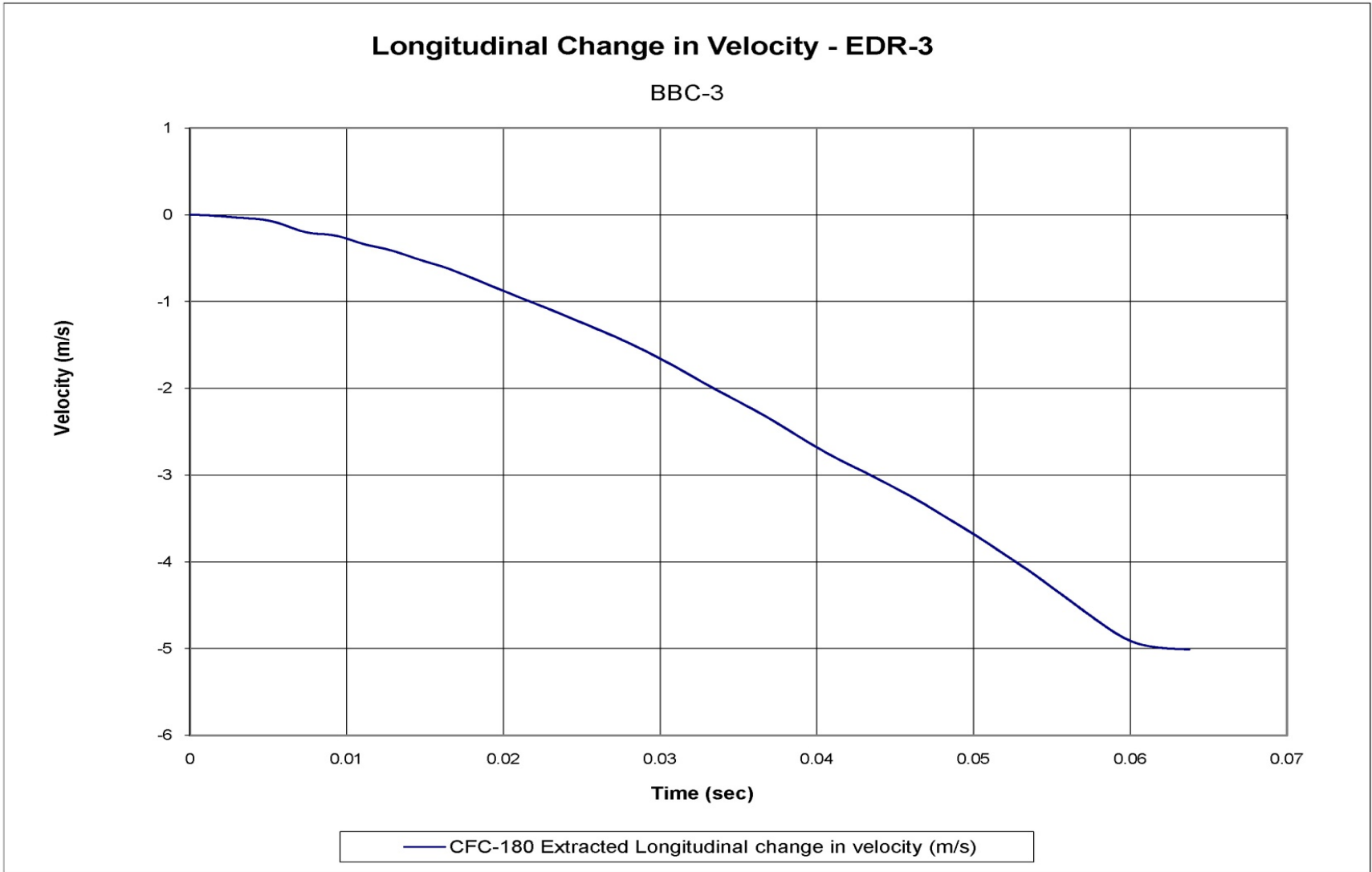

Figure D-8. Longitudinal Change in Velocity (EDR-3), Test No. BBC-3

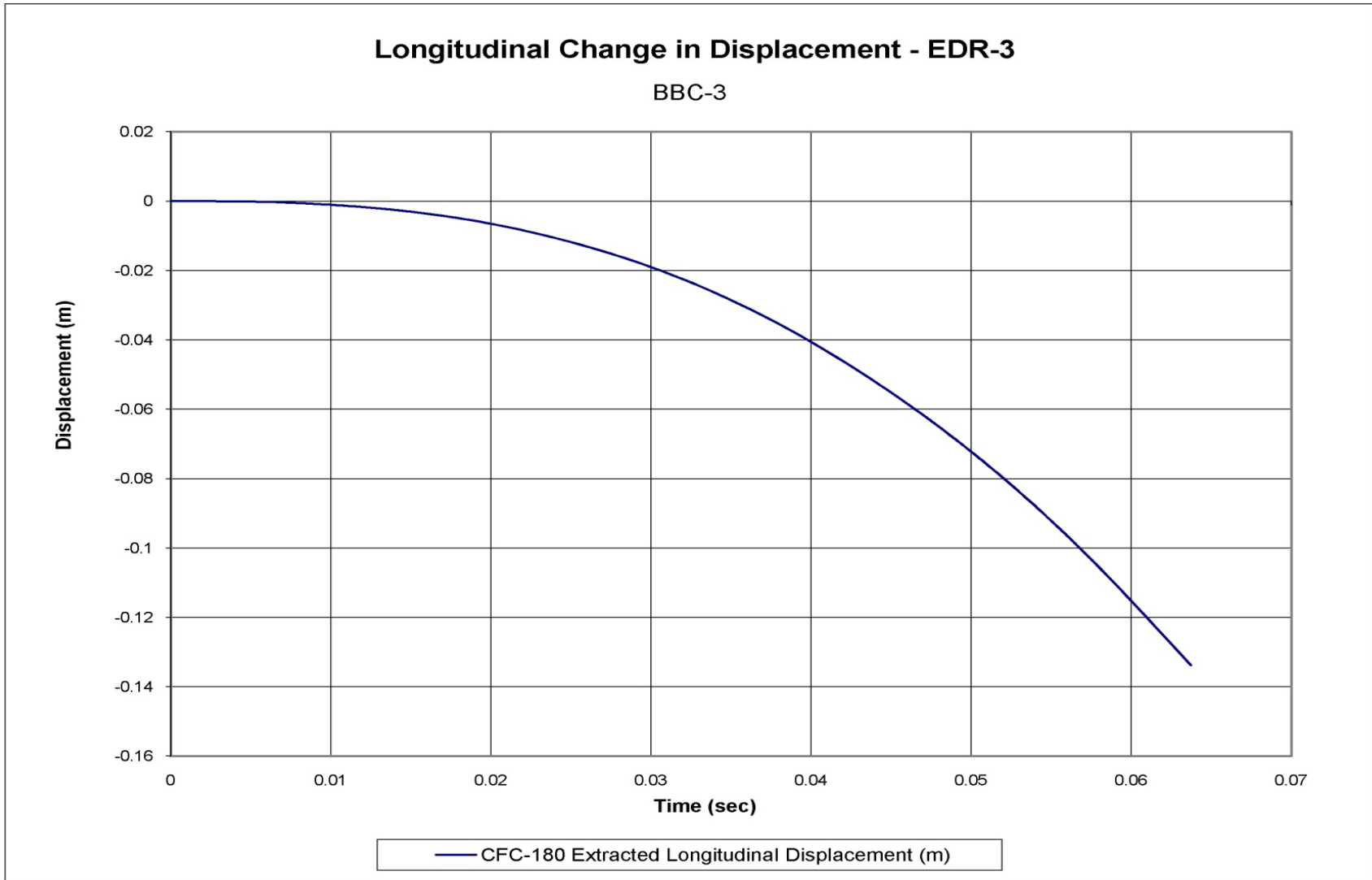

Figure D-9. Longitudinal Change in Displacement (EDR-3), Test No. BBC-3

Appendix E. Accelerometer Data Plots, Test No. BBC-4

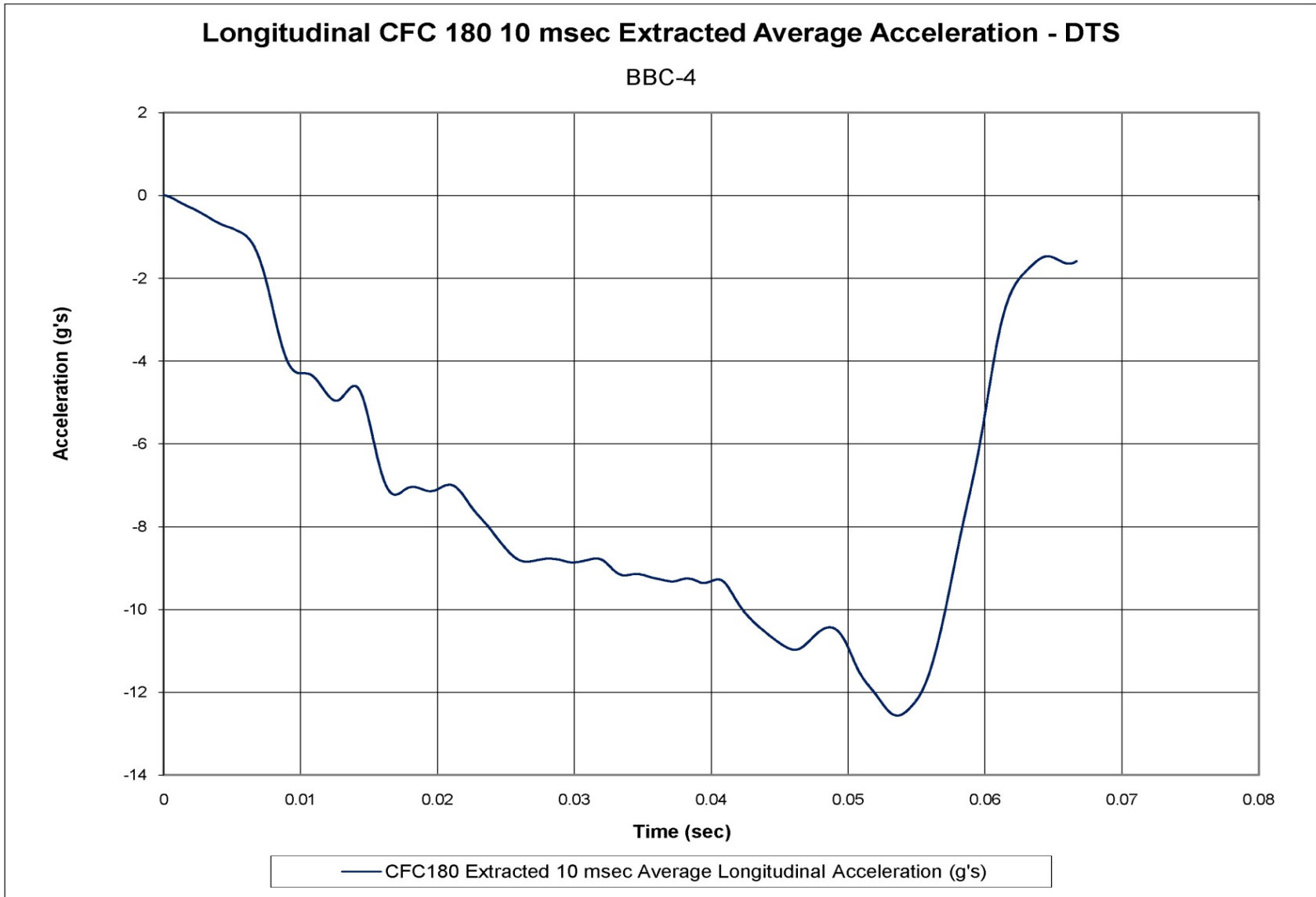

Figure E-1. Longitudinal Deceleration (DTS-BF57H), Test No. BBC-4

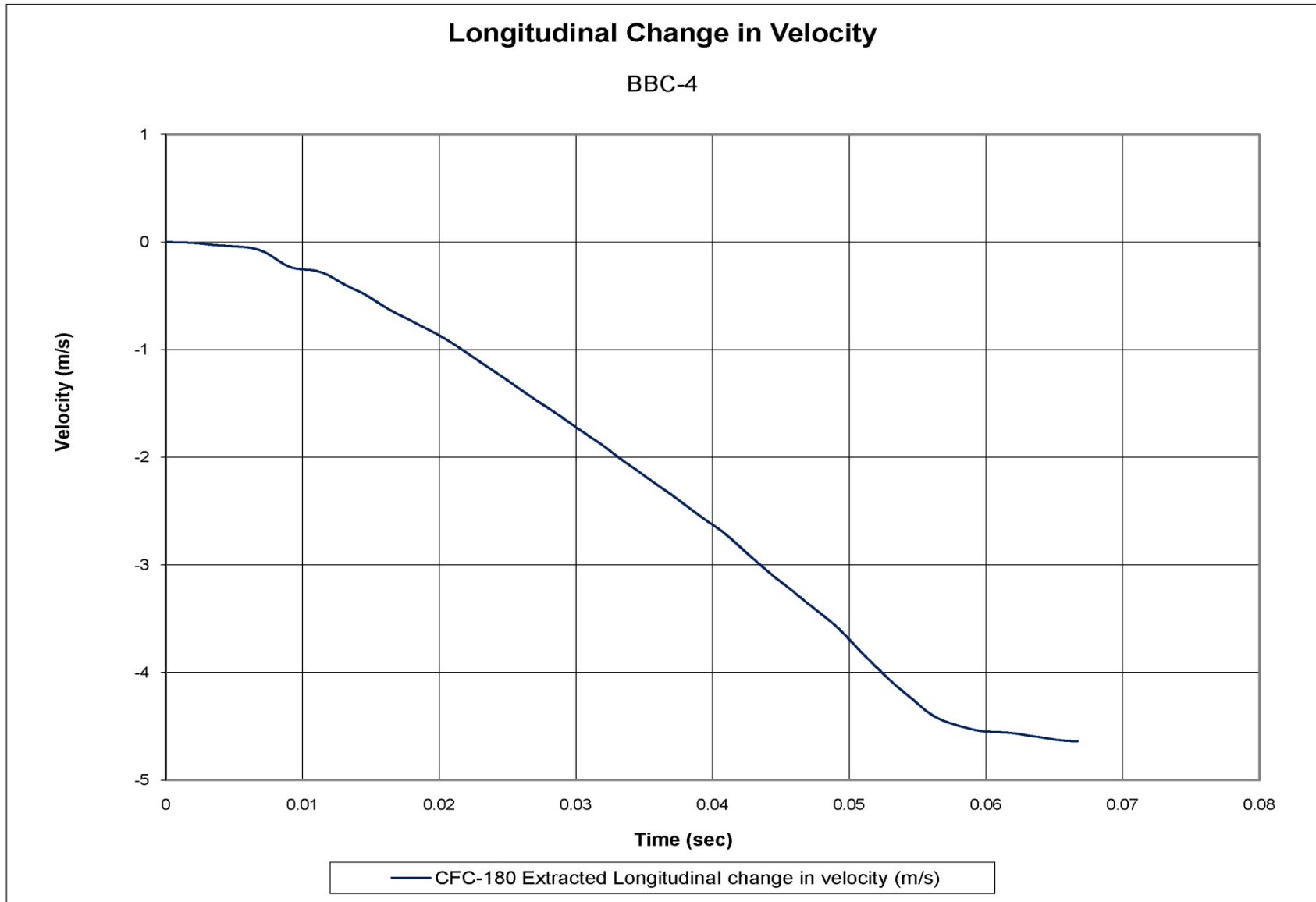

Figure E-2. Longitudinal Change in Velocity (DTS-BF57H), Test No. BBC-4

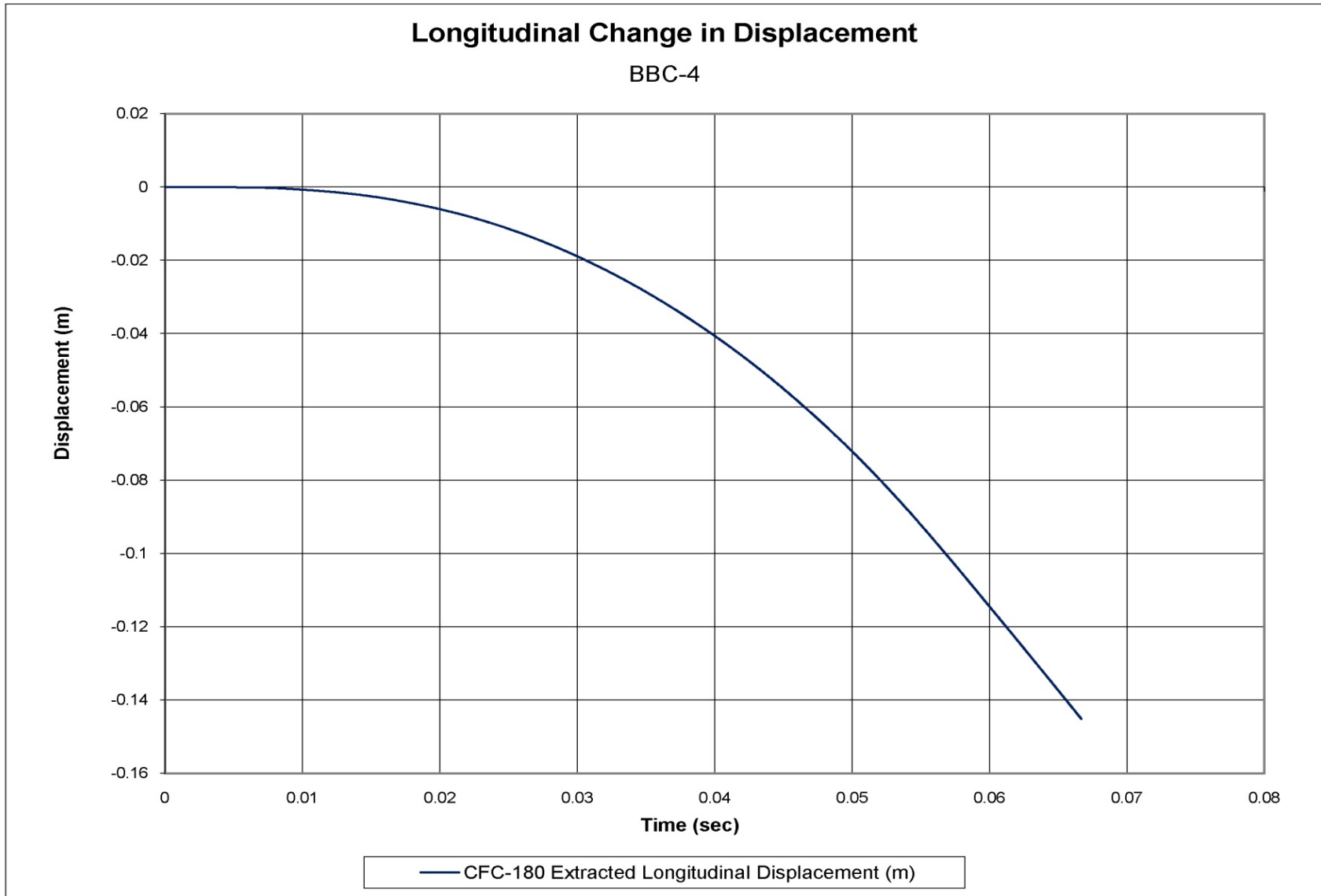

Figure E-3. Longitudinal Change in Displacement (DTS-BF57H), Test No. BBC-4

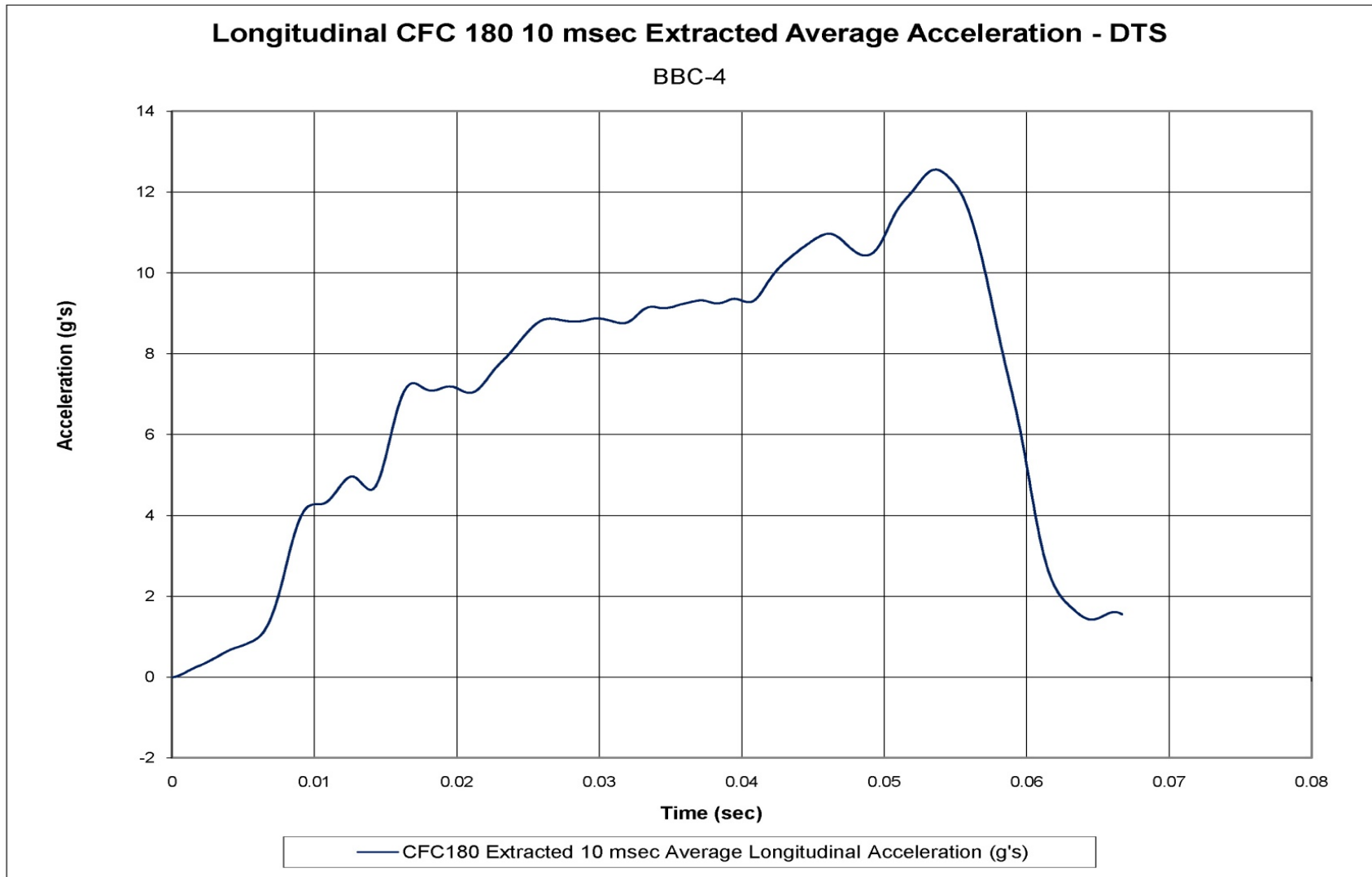

Figure E-4. Longitudinal Deceleration (DTS-CM54H), Test No. BBC-4

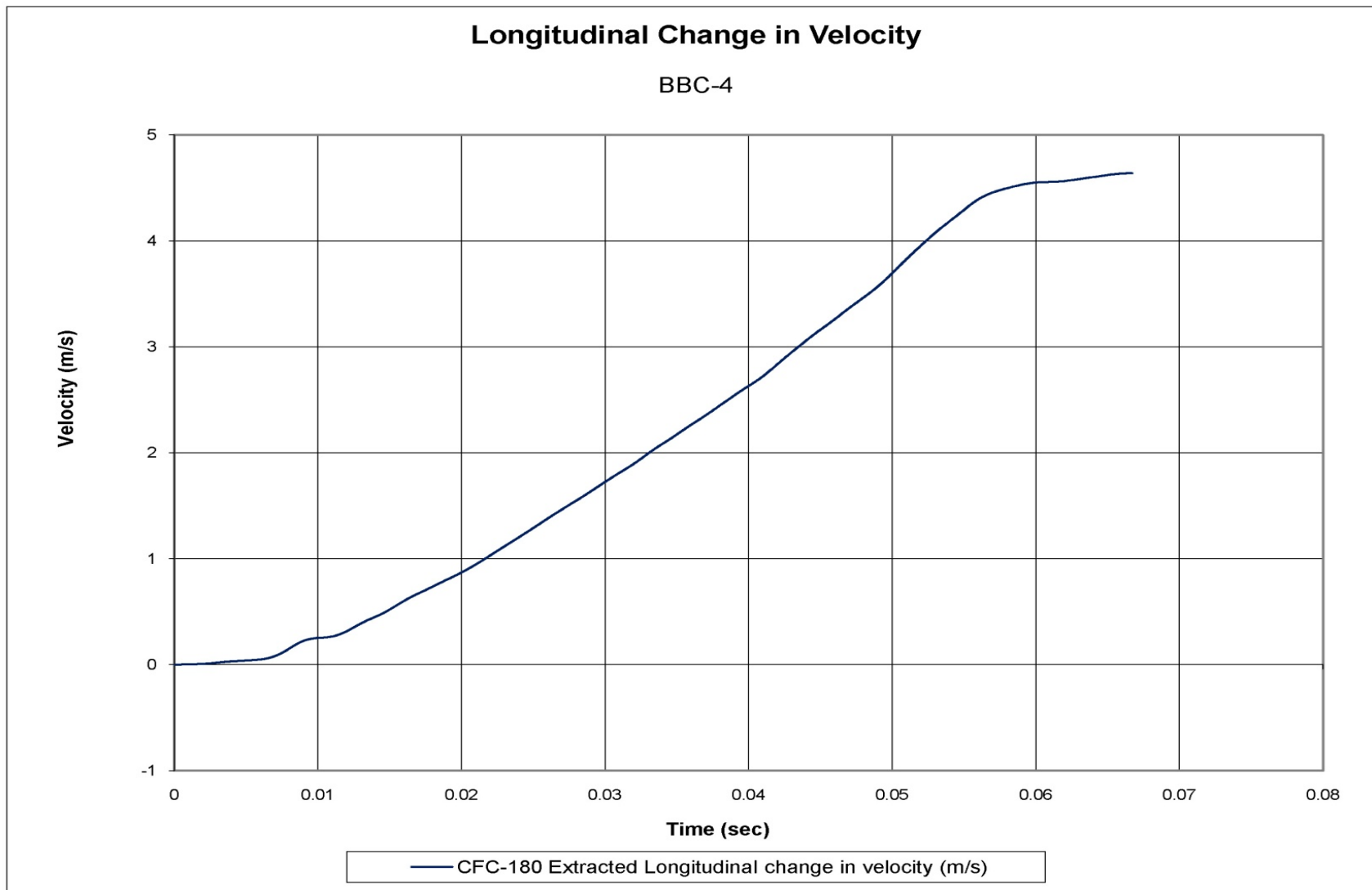

Figure E-5. Longitudinal Change in Velocity (DTS-CM54H), Test No. BBC-4

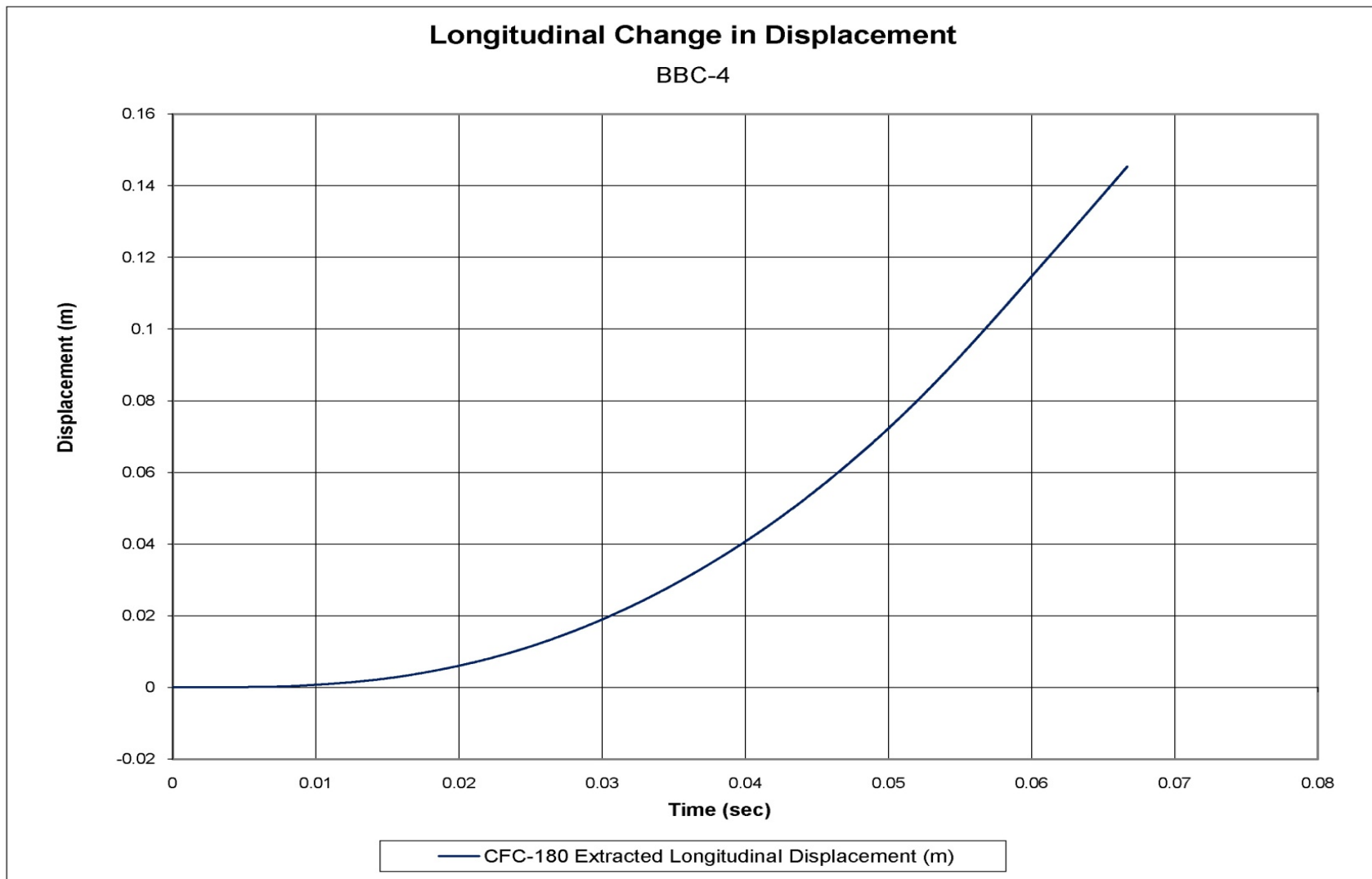

Figure E-6. Longitudinal Change in Displacement (DTS-CM54H), Test No. BBC-4

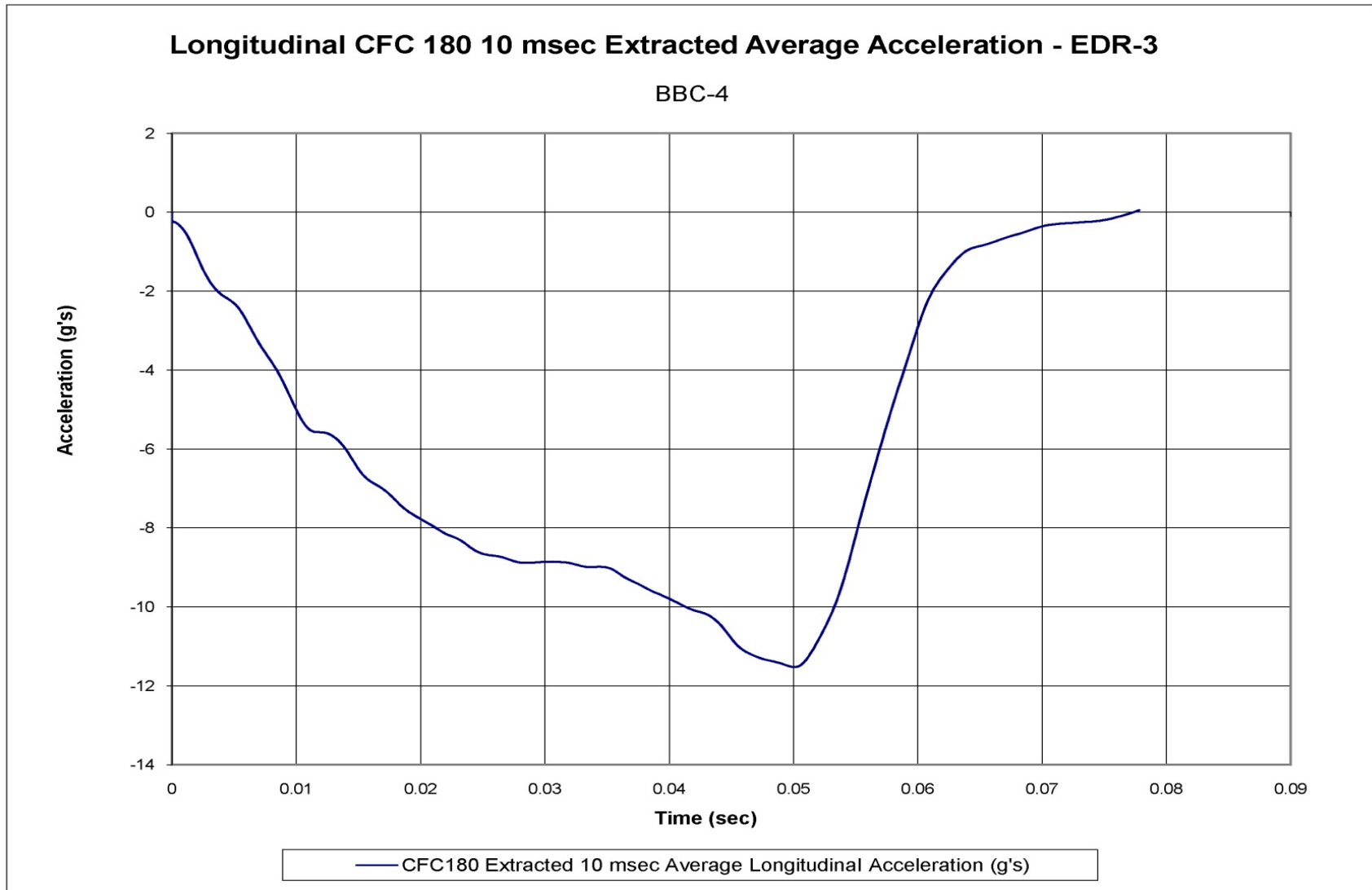

Figure E-7. Longitudinal Deceleration (EDR-3), Test No. BBC-4

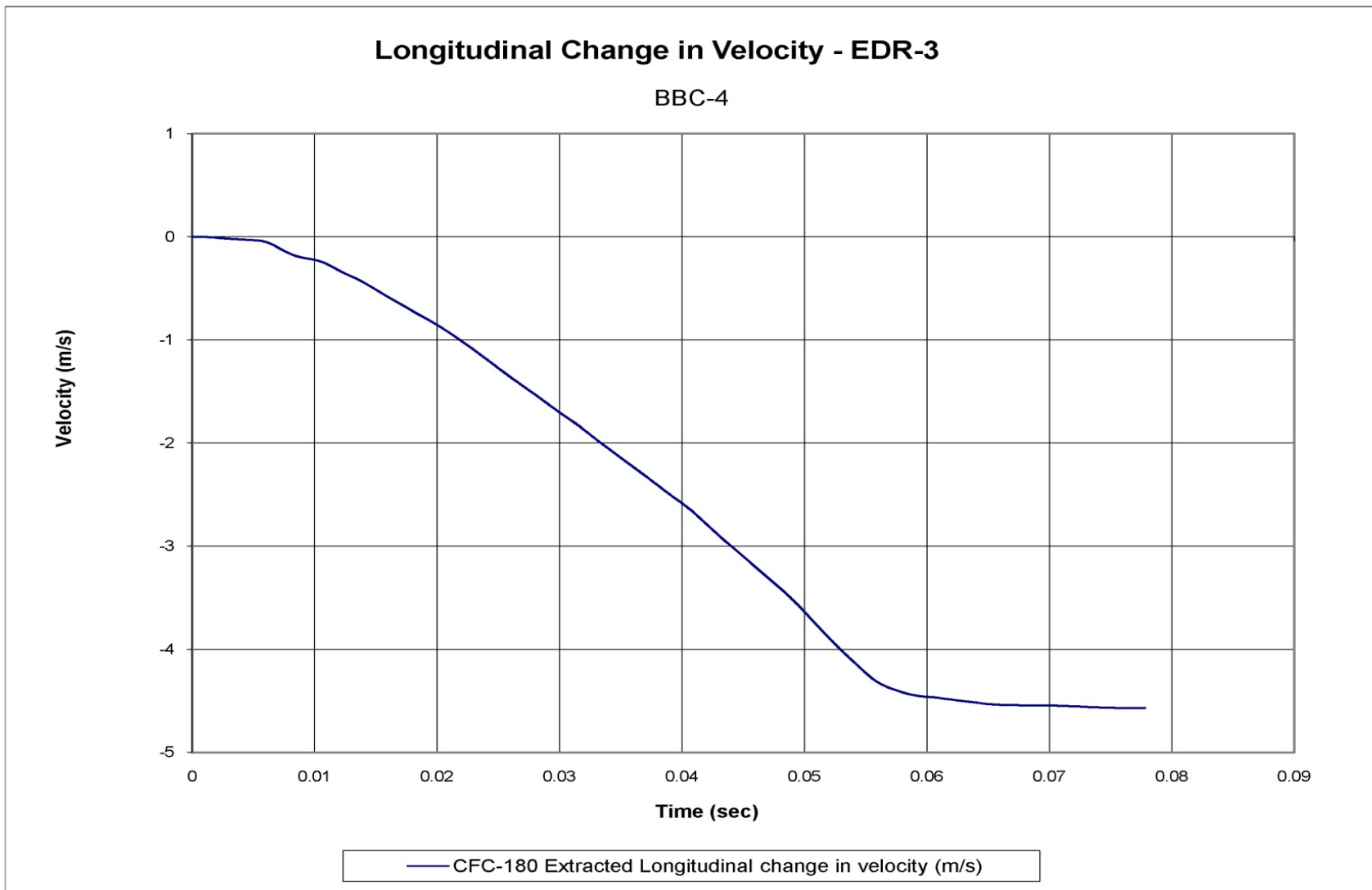

Figure E-8. Longitudinal Change in Velocity (EDR-3), Test No. BBC-4

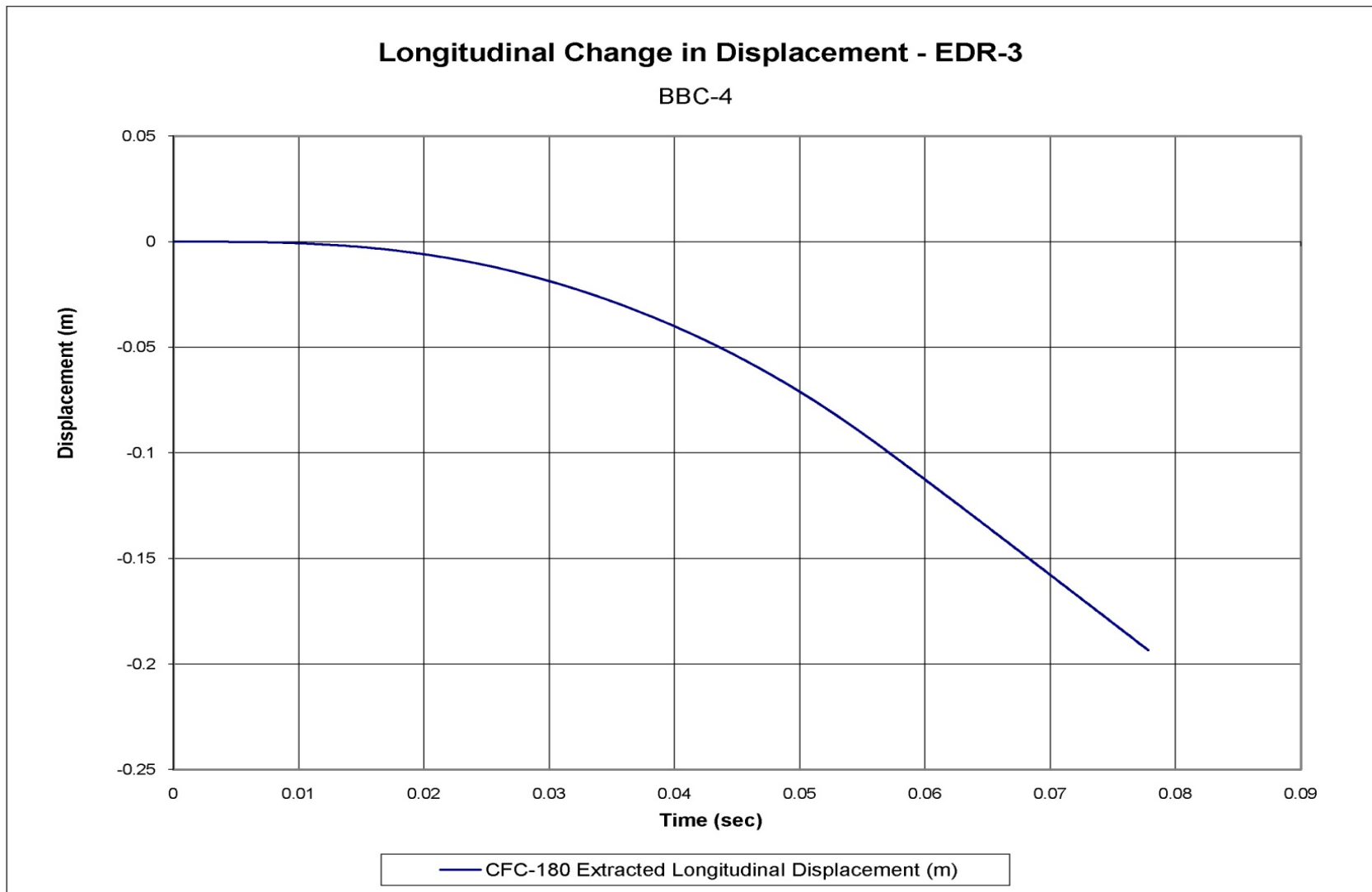

Figure E-9. Longitudinal Change in Displacement (EDR-3), Test No. BBC-4

Appendix F. Accelerometer Data Plots, Test No. BBC-5

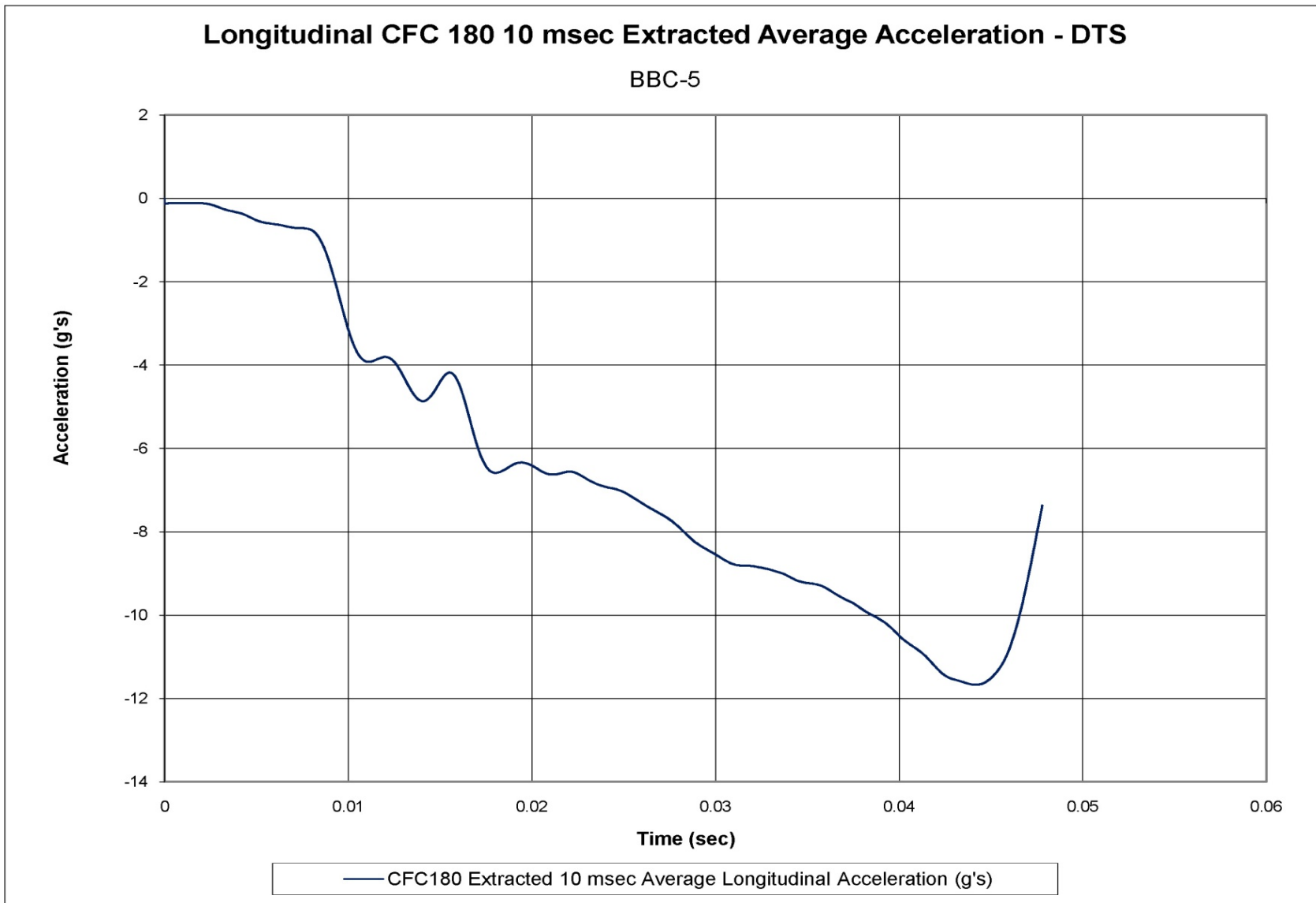

Figure F-1. Longitudinal Deceleration (DTS-BF57H), Test No. BBC-5

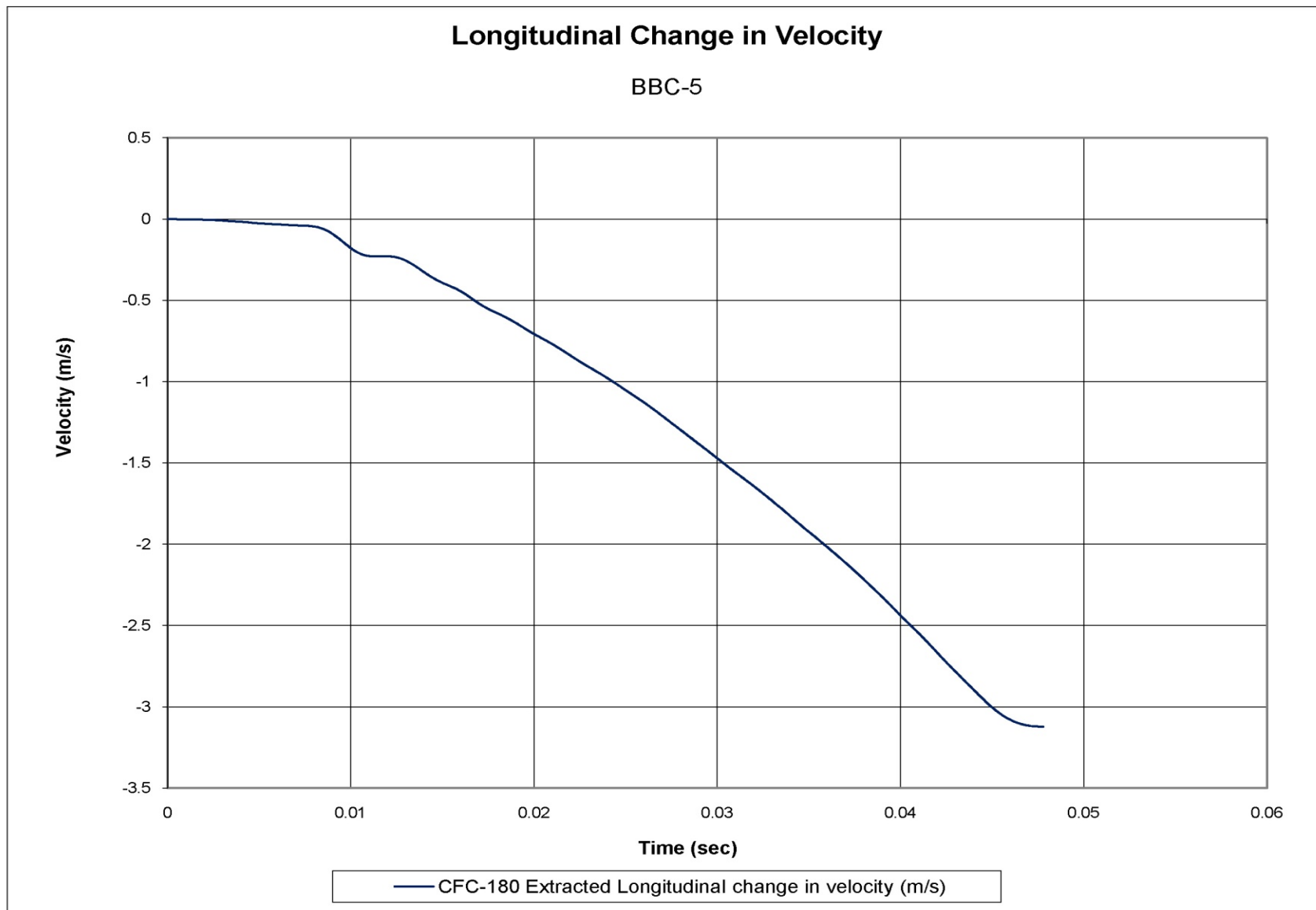

Figure F-2. Longitudinal Change in Velocity (DTS-BF57H), Test No. BBC-5

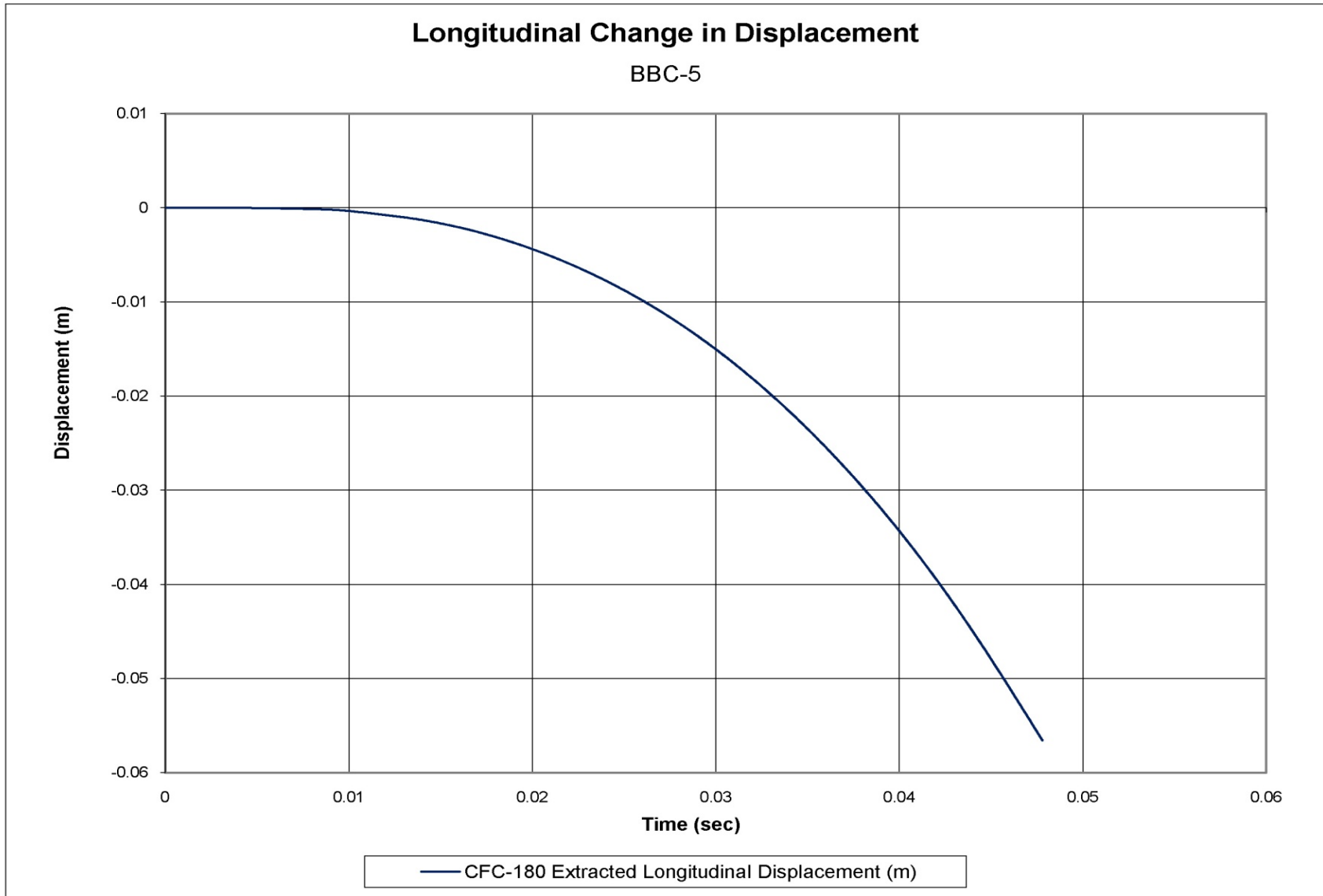

Figure F-3. Longitudinal Change in Displacement (DTS-BF57H), Test No. BBC-5

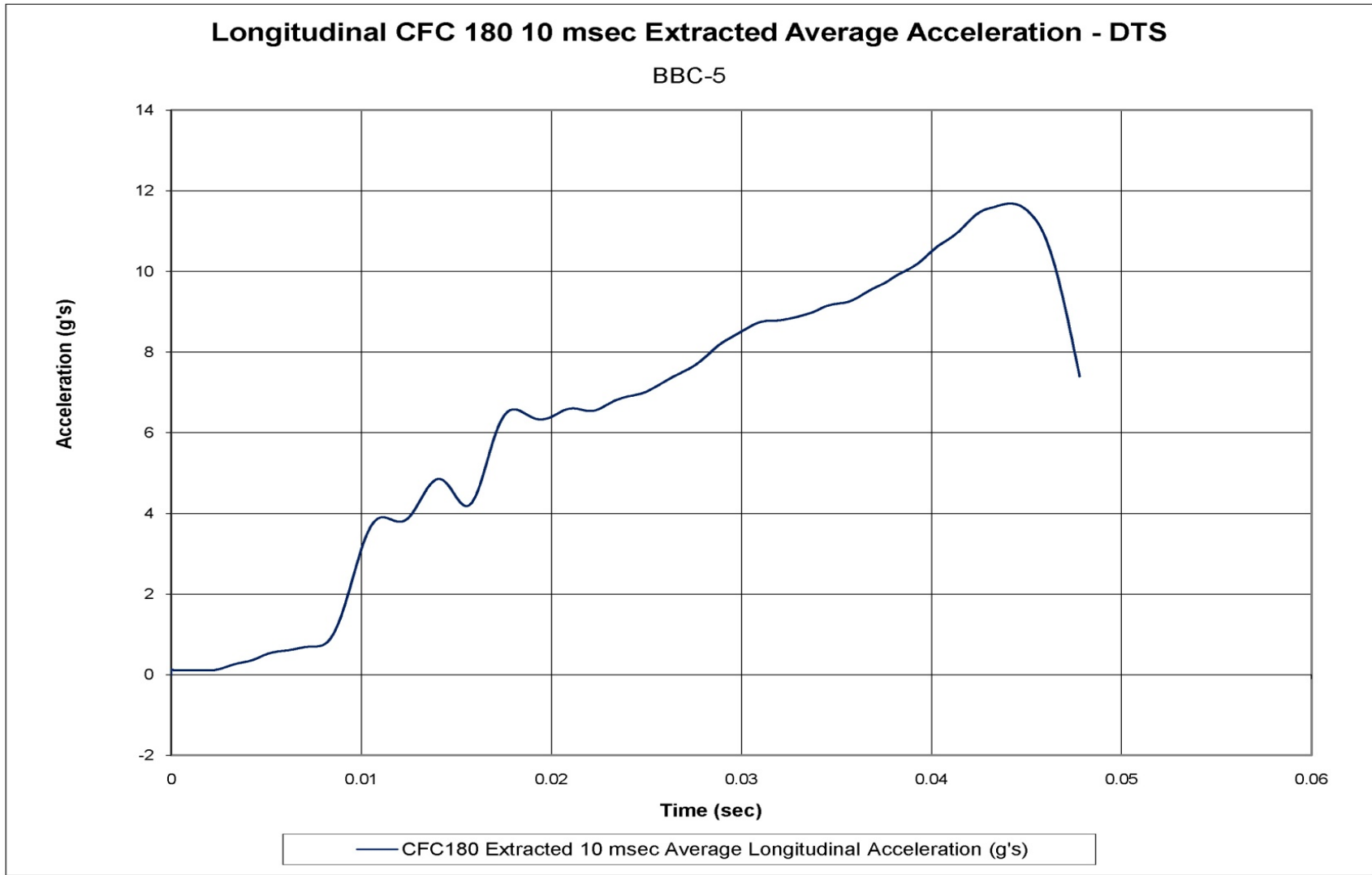

Figure F-4. Longitudinal Deceleration (DTS-CM54H), Test No. BBC-5

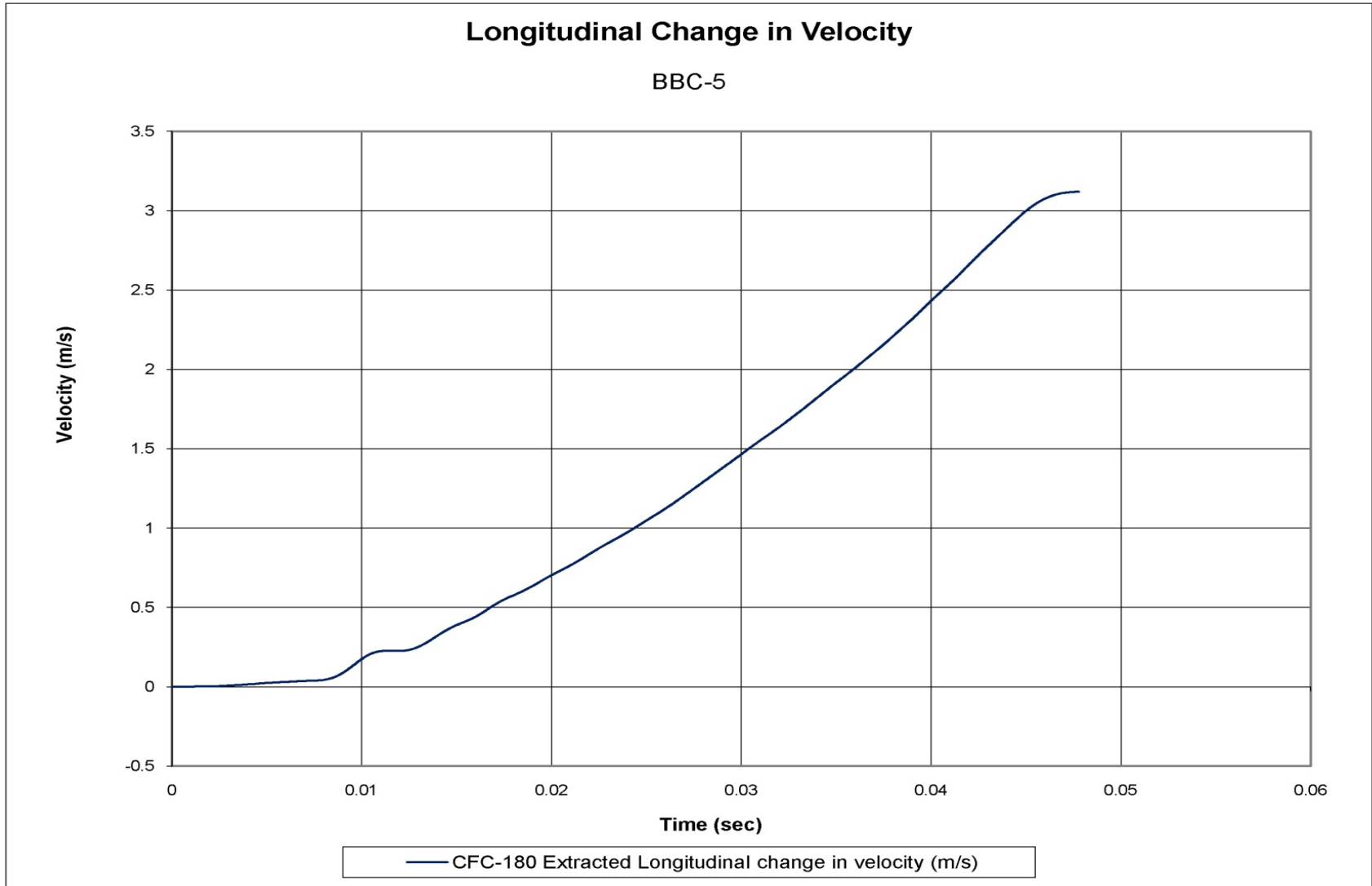

Figure F-5. Longitudinal Change in Velocity (DTS-CM54H), Test No. BBC-5

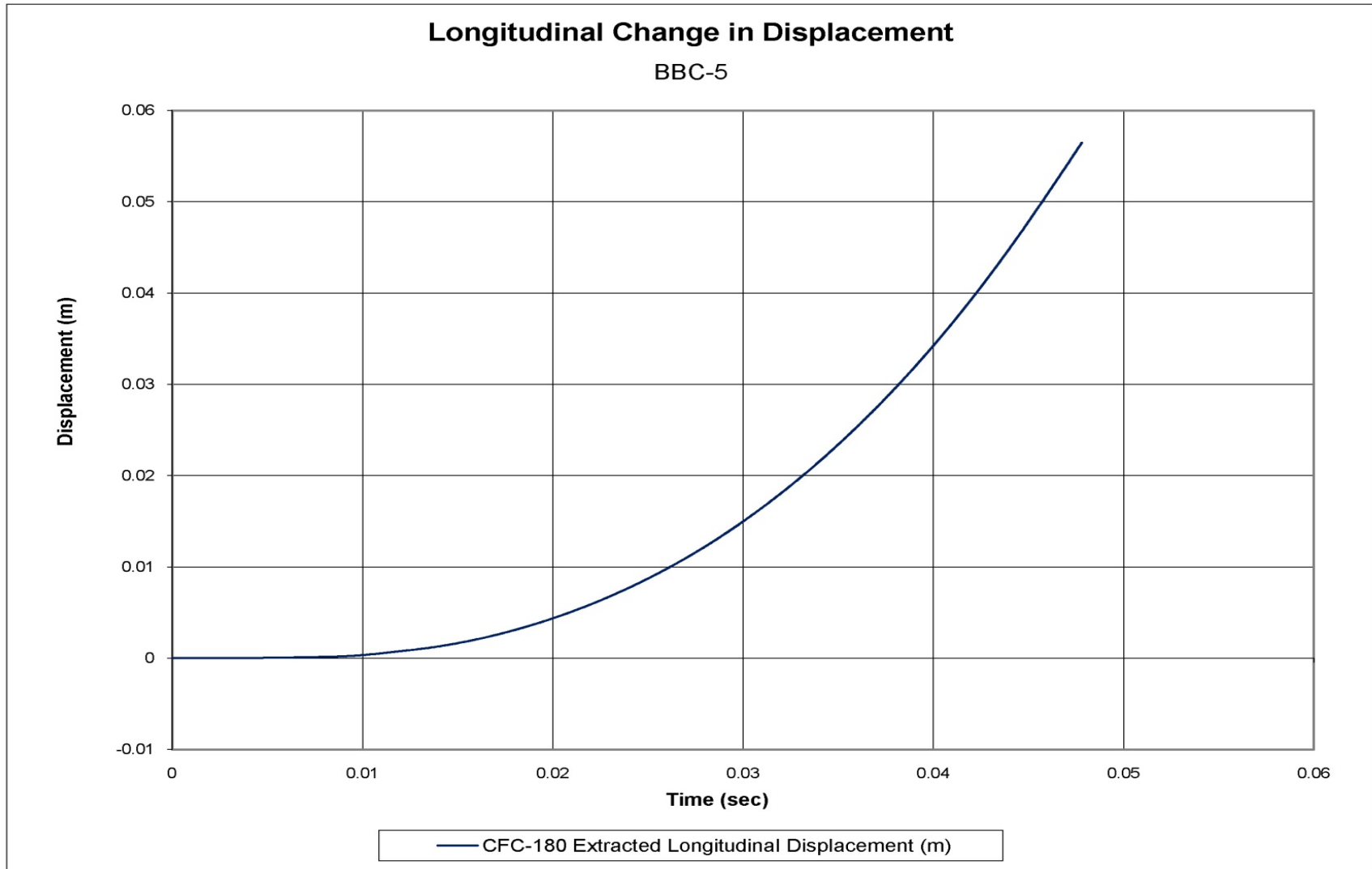

Figure F-6. Longitudinal Change in Displacement (DTS-CM54H), Test No. BBC-5

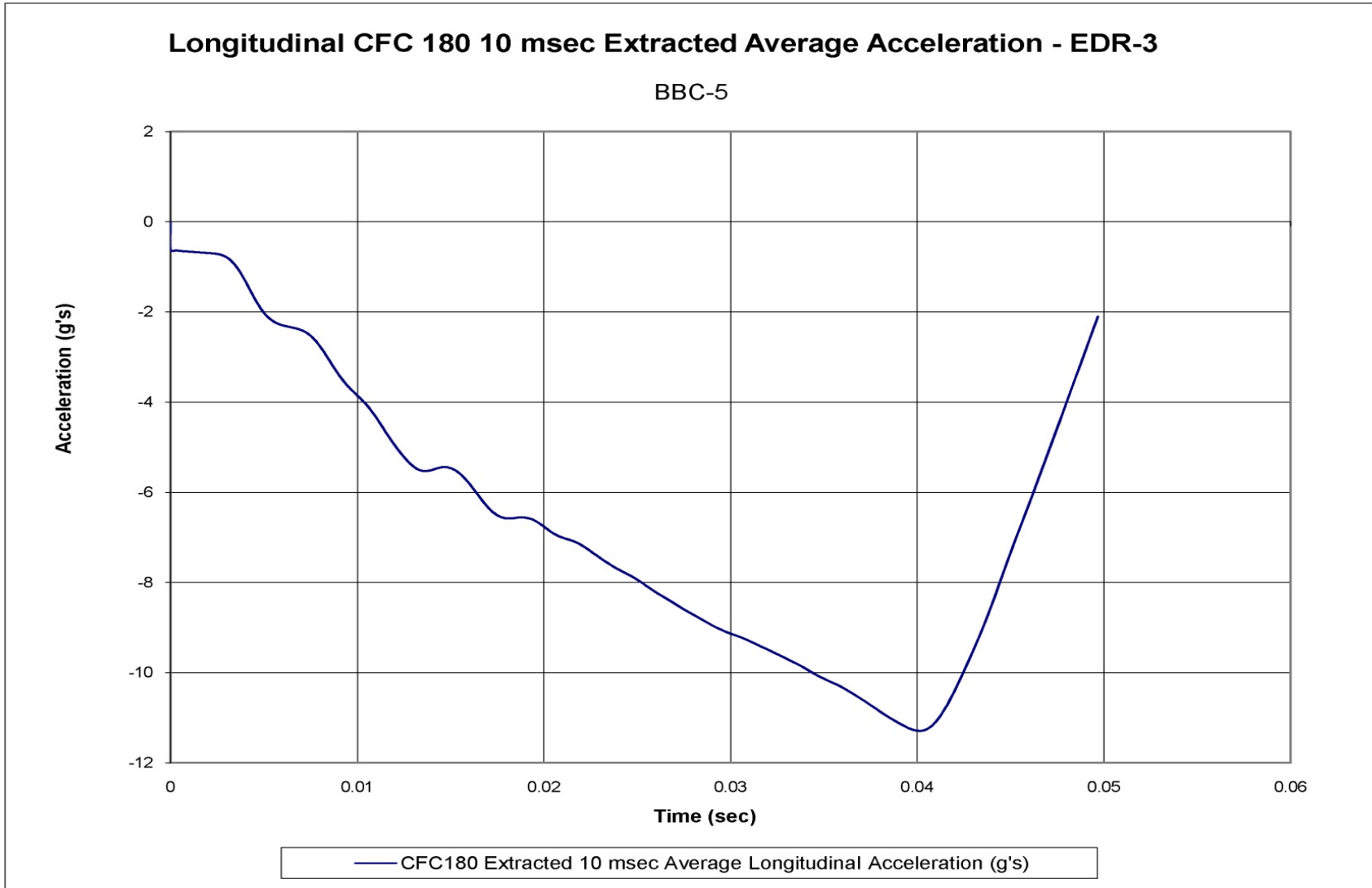

Figure F-7. Longitudinal Deceleration (EDR-3), Test No. BBC-5

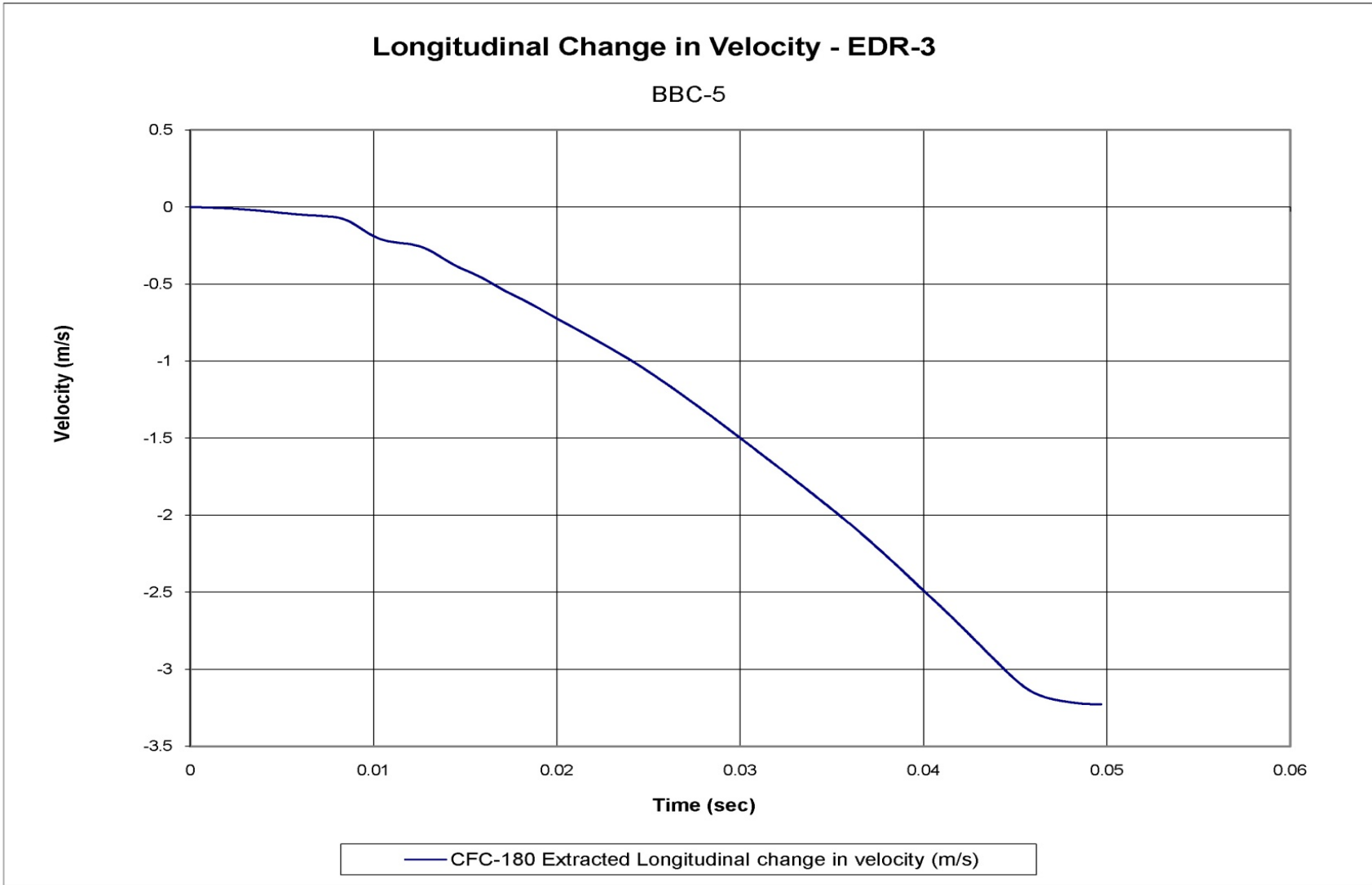

Figure F-8. Longitudinal Change in Velocity (EDR-3), Test No. BBC-5

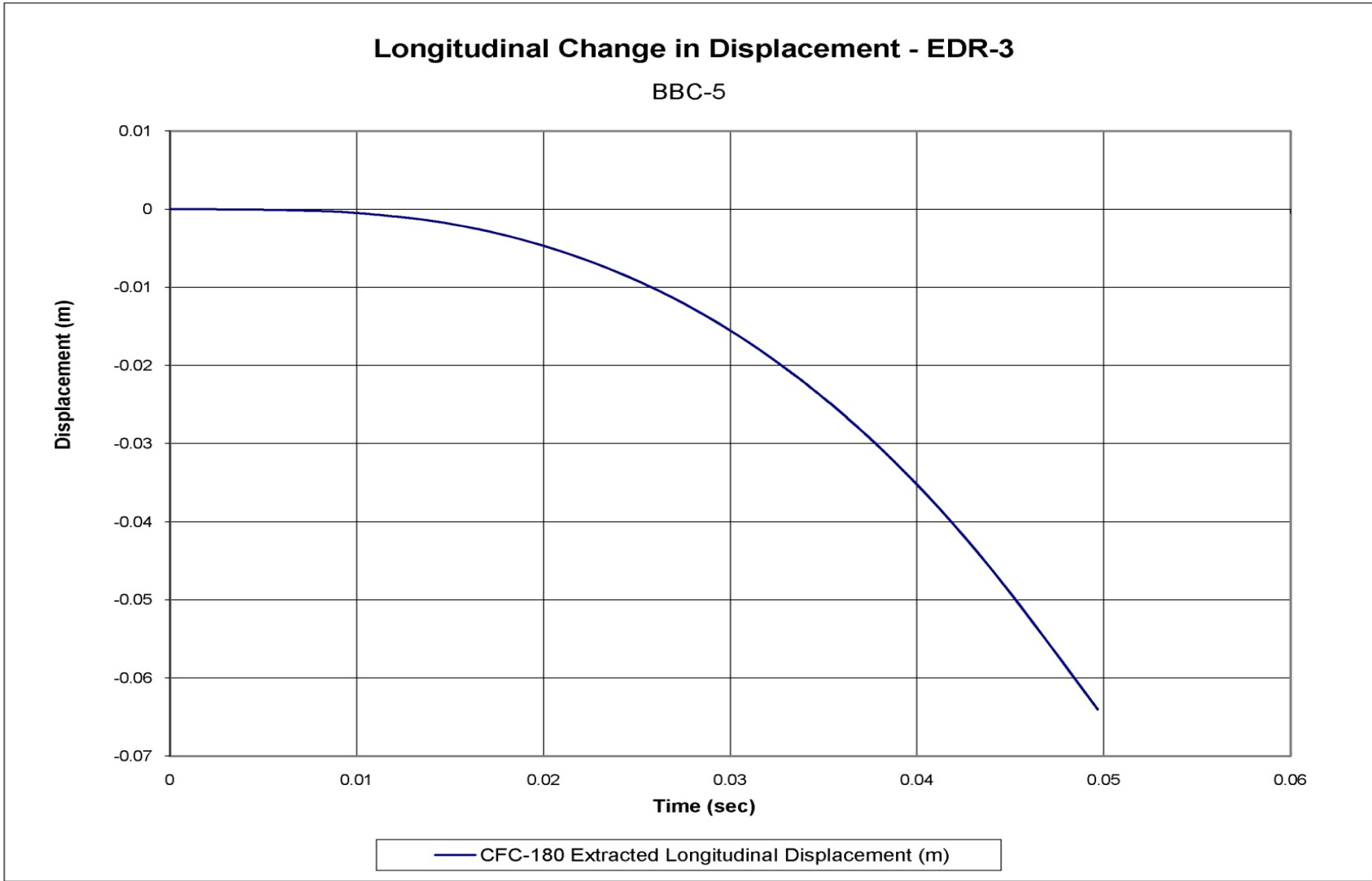

Figure F-9. Longitudinal Change in Displacement (EDR-3), Test No. BBC-5

Appendix G. Accelerometer Data Plots, Test No. BBC-6

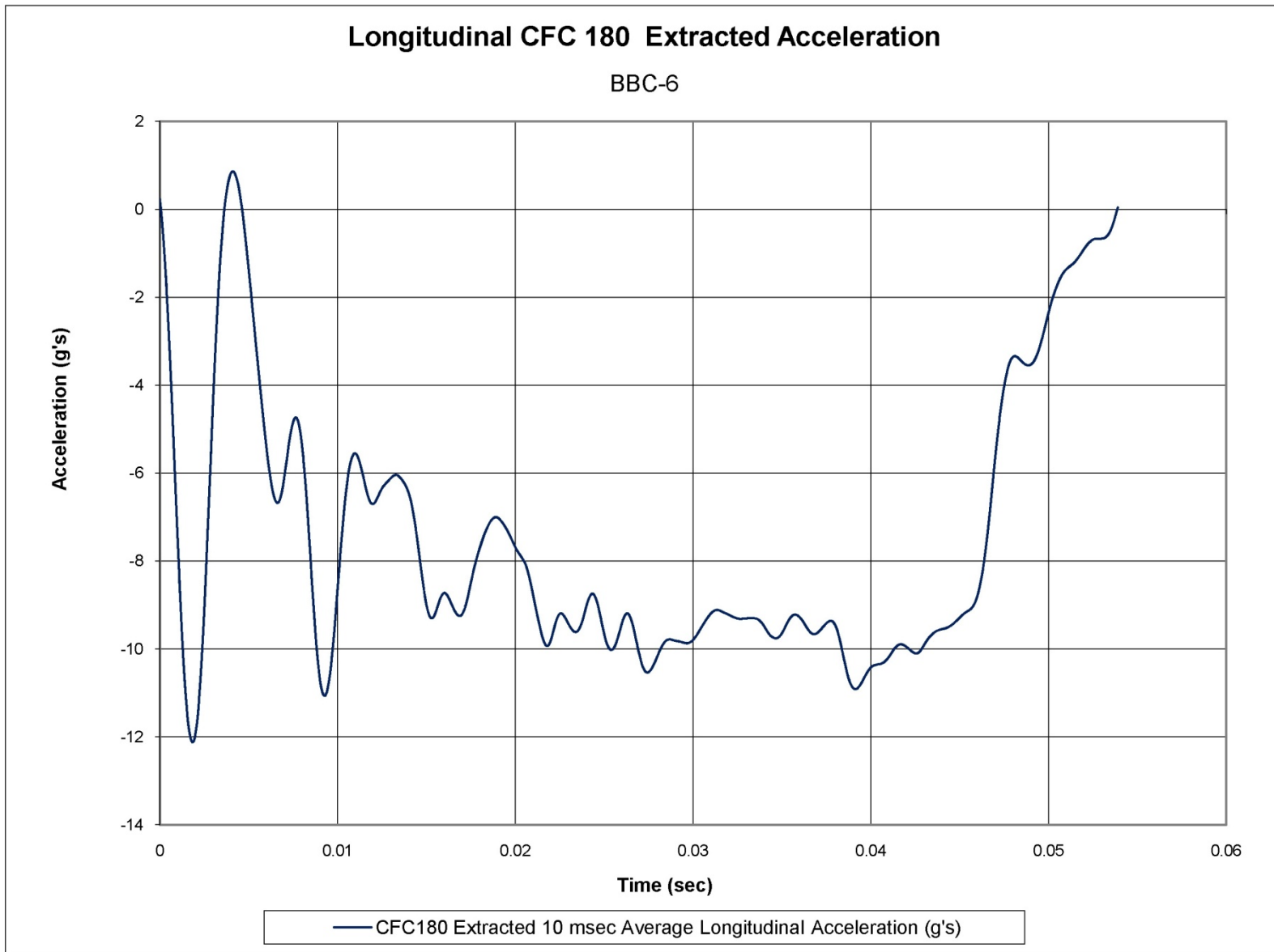

Figure G-1. Longitudinal Deceleration (DTS-BF57H), Test No. BBC-6

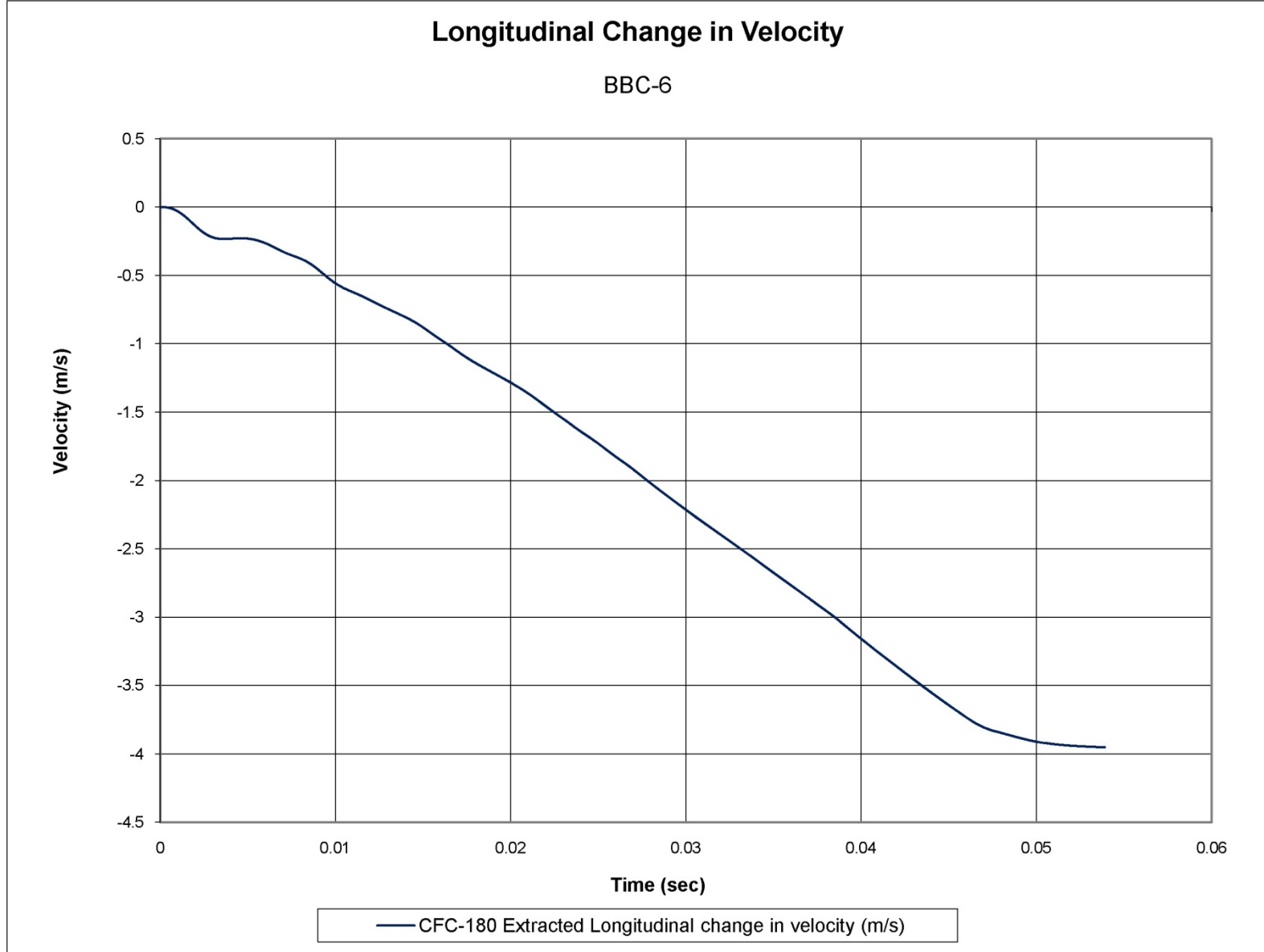

Figure G-2. Longitudinal Change in Velocity (DTS-BF57H), Test No. BBC-6

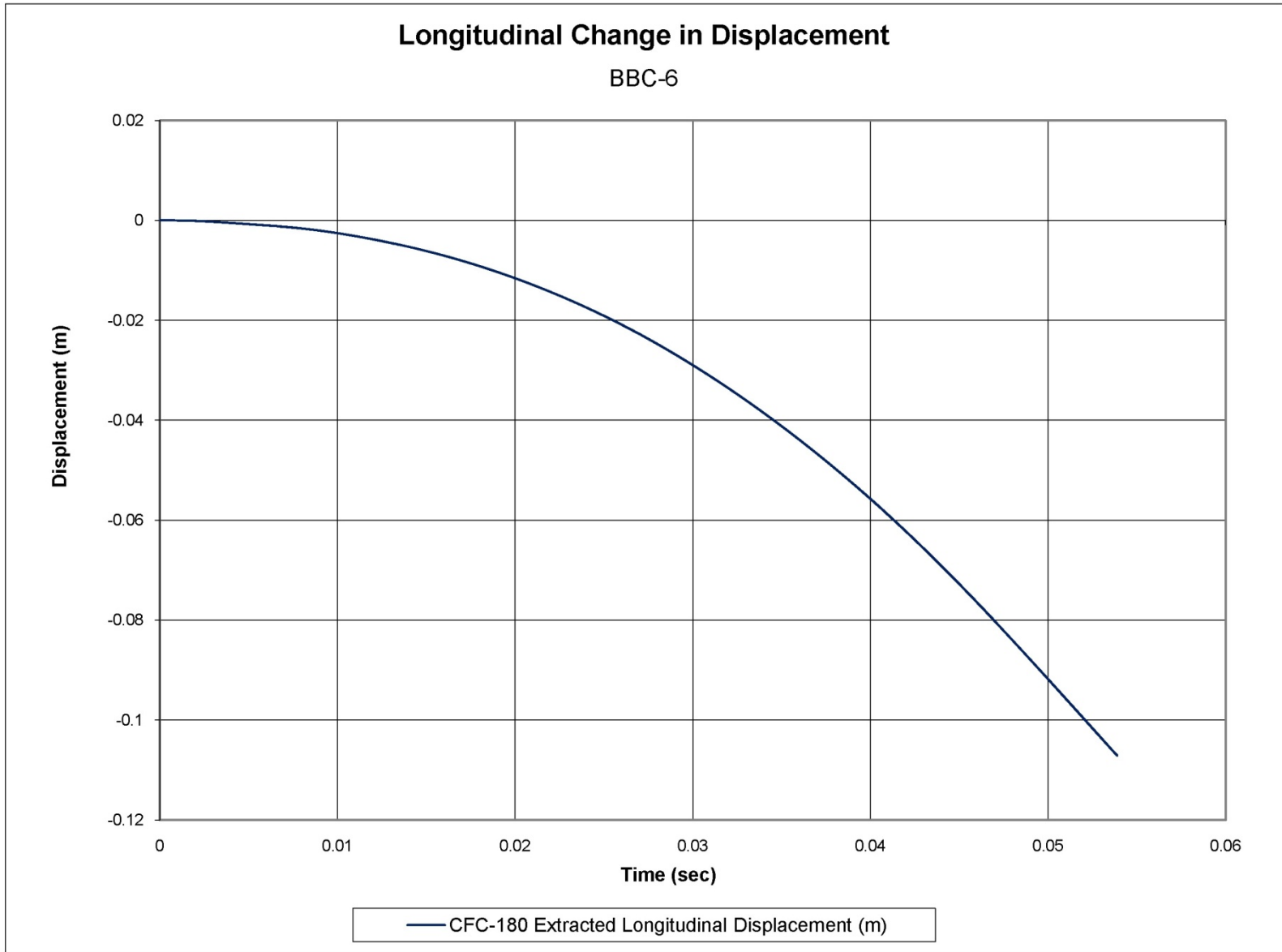

Figure G-3. Longitudinal Change in Displacement (DTS-BF57H), Test No. BBC-6

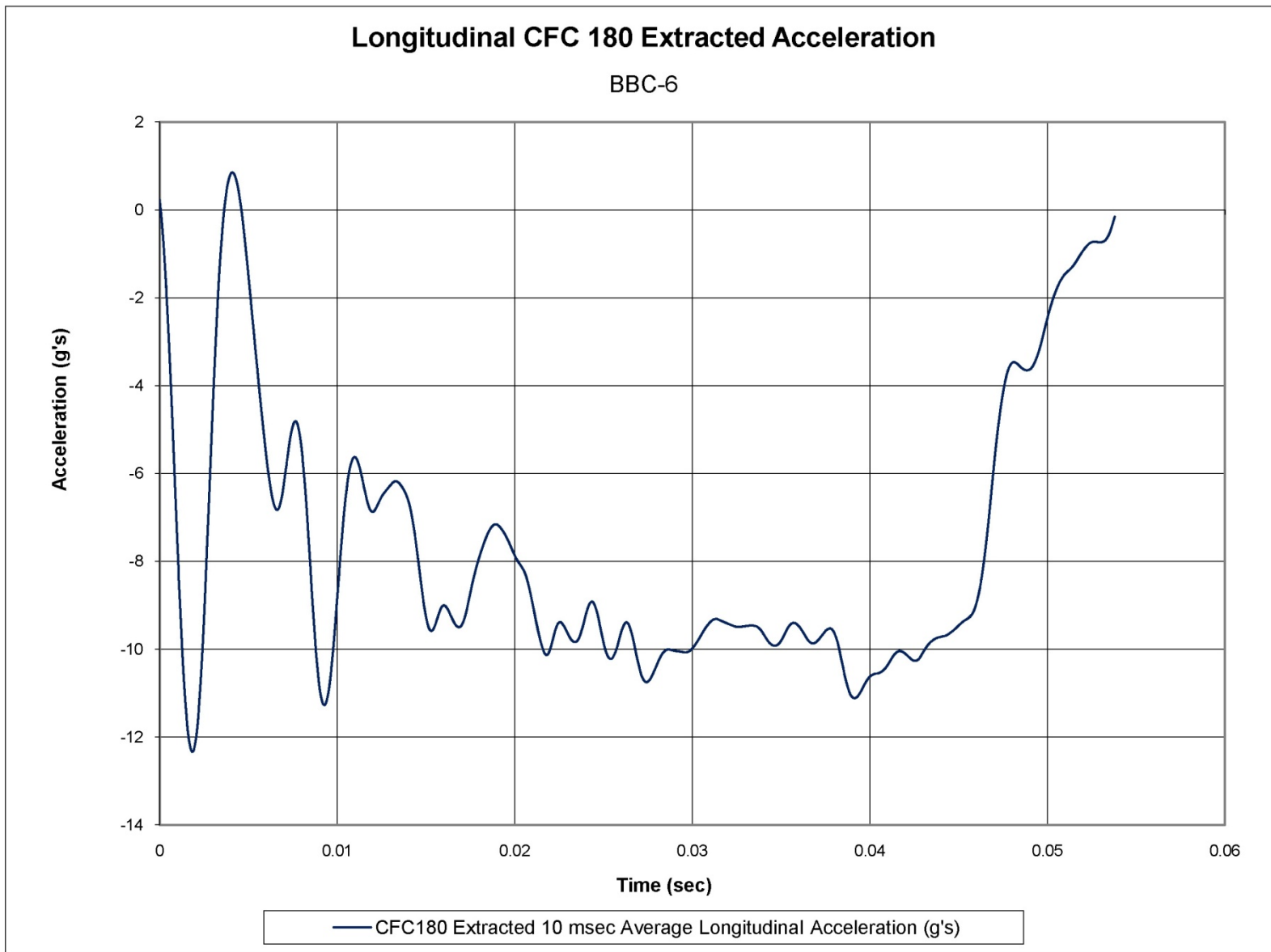

Figure G-4. Longitudinal Deceleration (DTS-CM54H), Test No. BBC-6

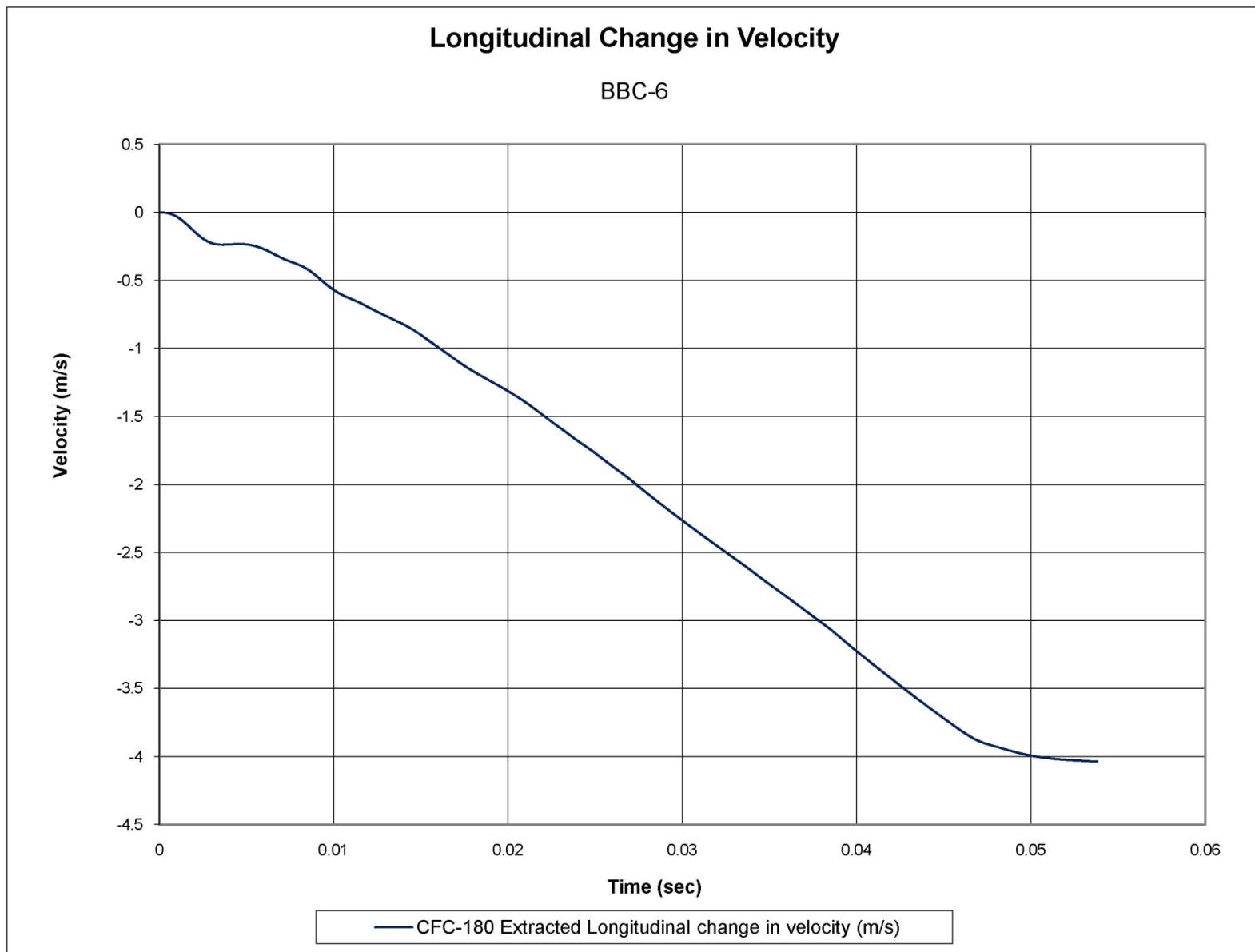

Figure G-5. Longitudinal Change in Velocity (DTS-CM54H), Test No. BBC-6

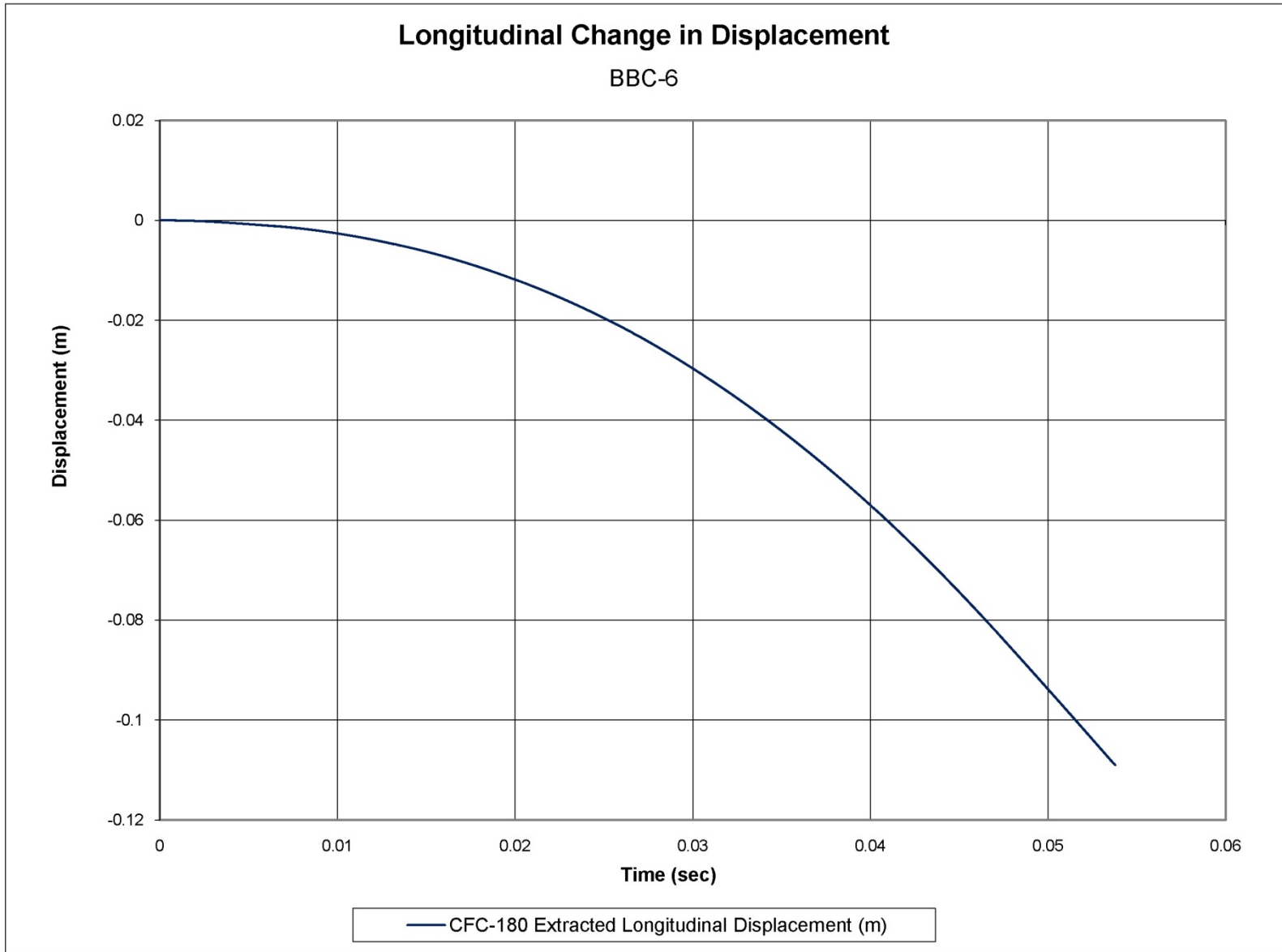

Figure G-6. Longitudinal Change in Displacement (DTS-CM54H), Test No. BBC-6

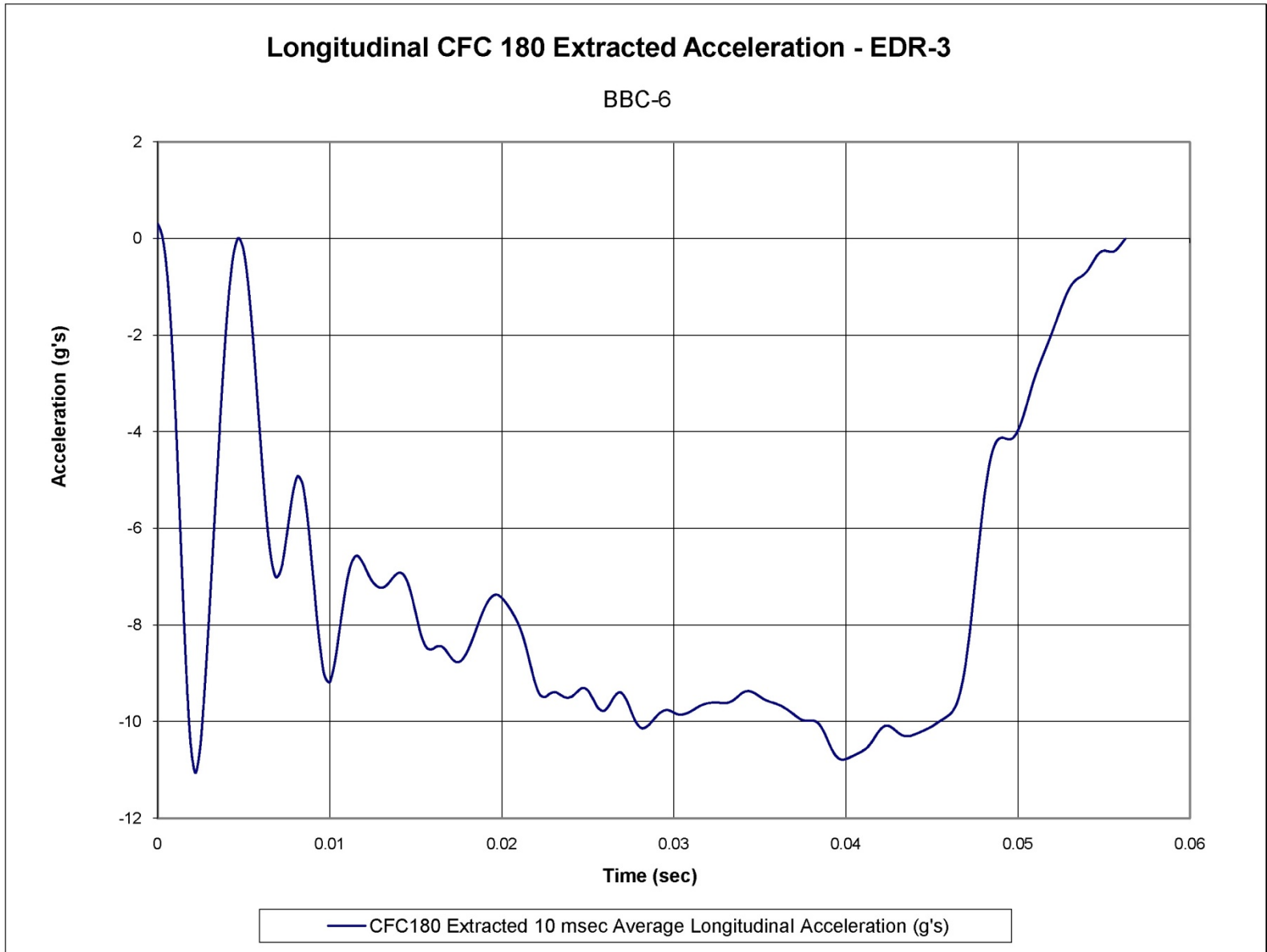

Figure G-7. Longitudinal Deceleration (EDR-3), Test No. BBC-6

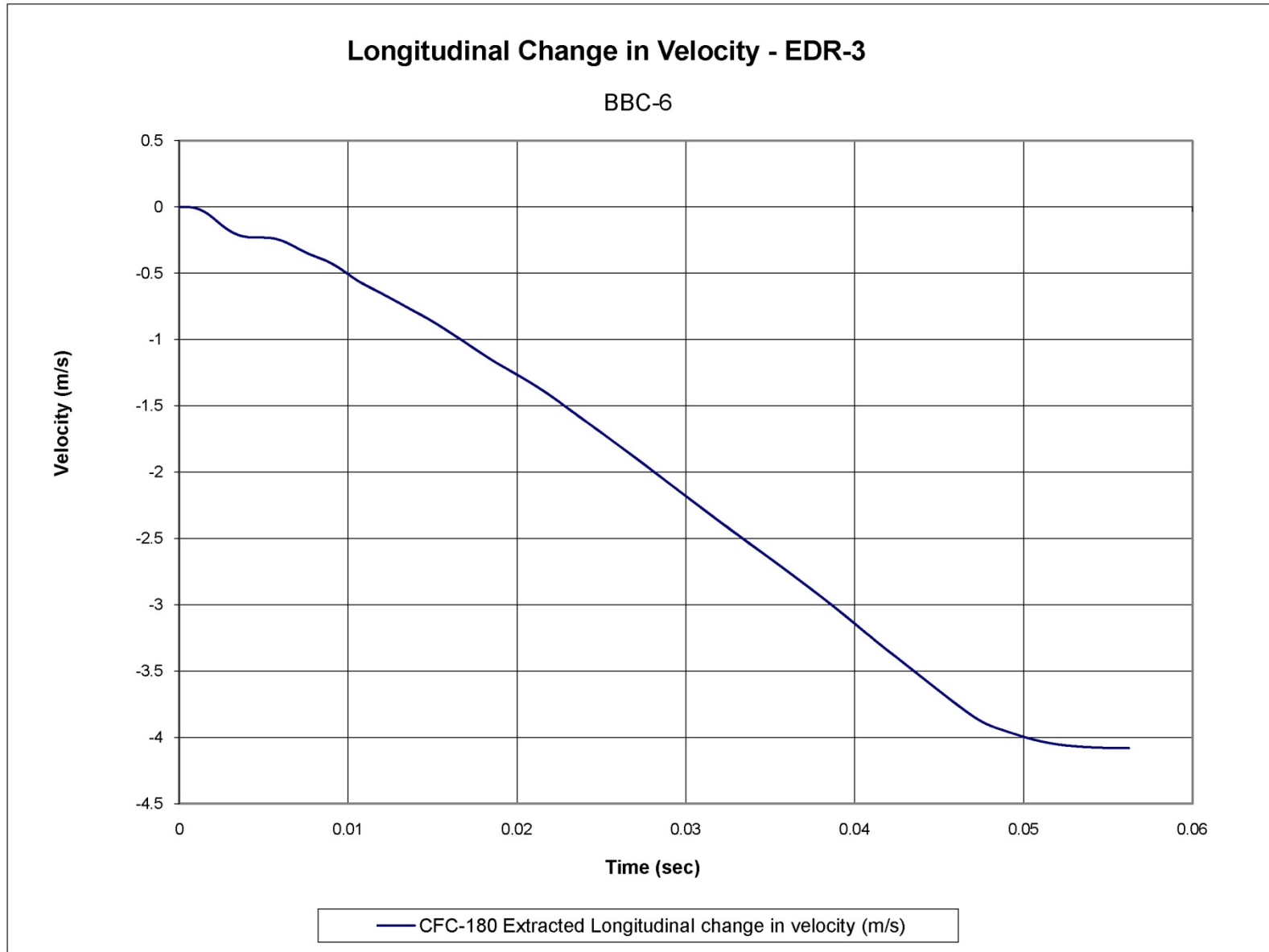
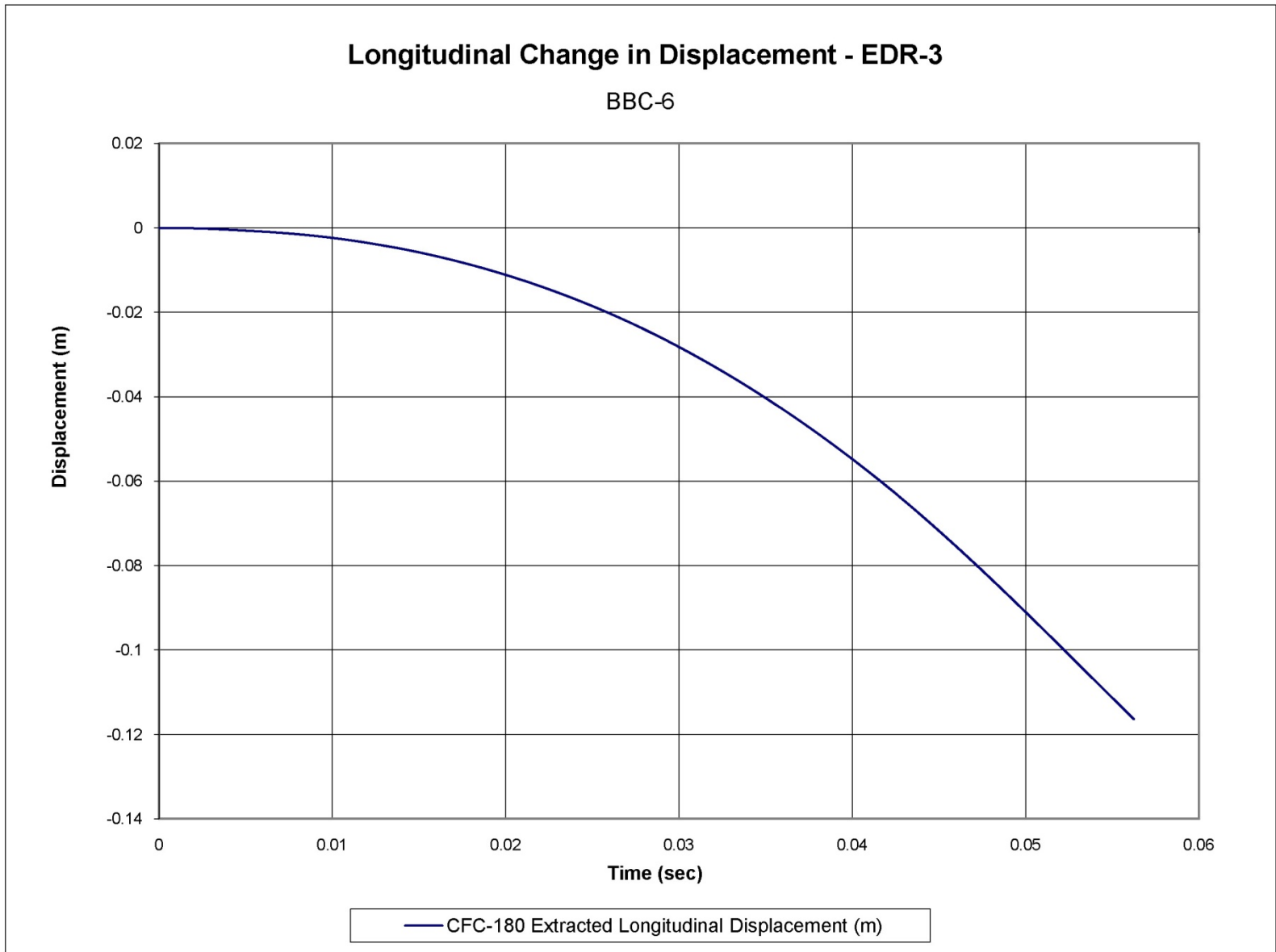

Figure G-8. Longitudinal Change in Velocity (EDR-3), Test No. BBC-6



Longitudinal Change in Displacement (EDR-3), Test No. BBC-6

Appendix H. Accelerometer Data Plots, Test No. BBC-7

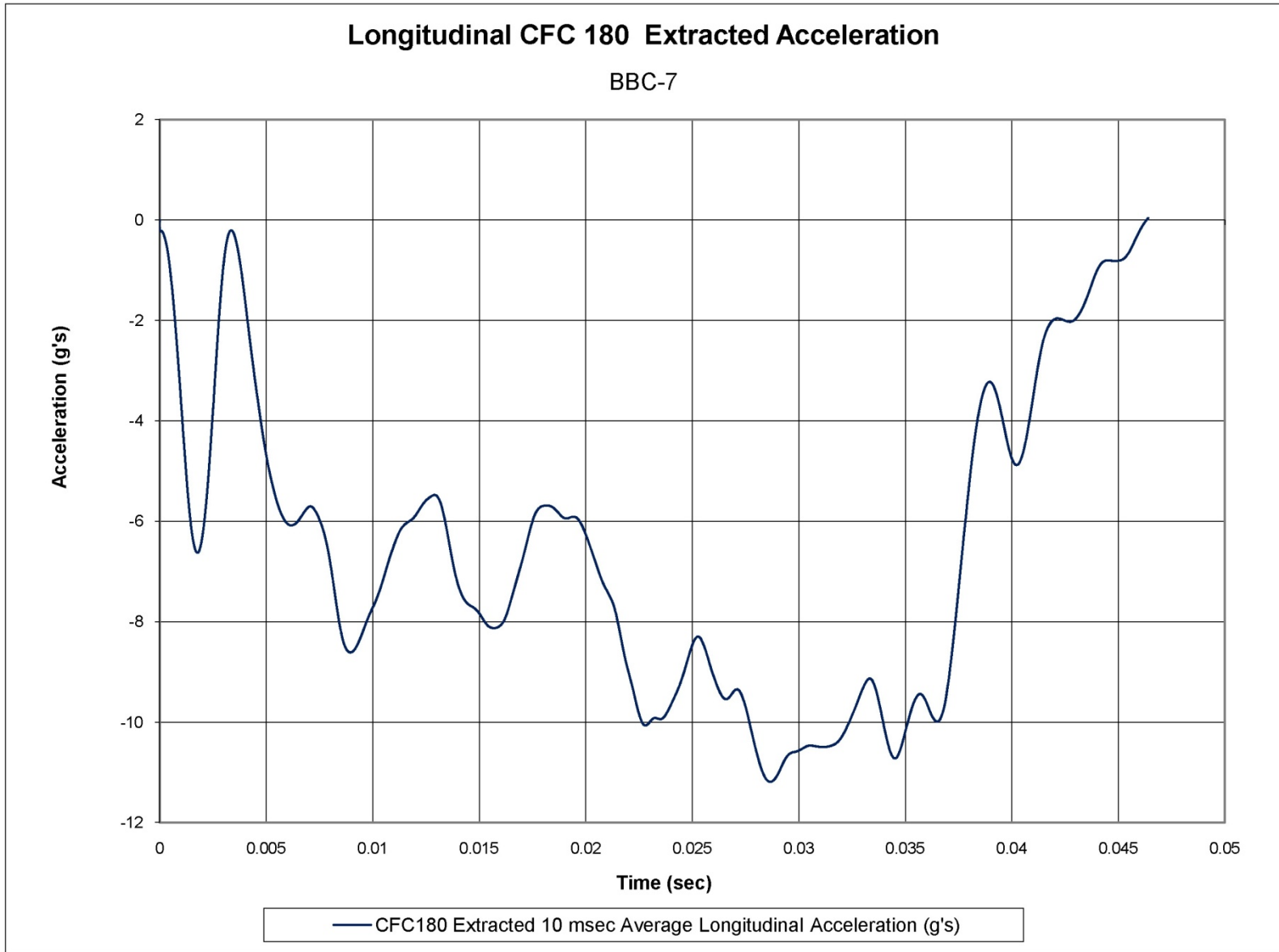

Figure H-1. Longitudinal Deceleration (DTS-BF57H), Test No. BBC-7

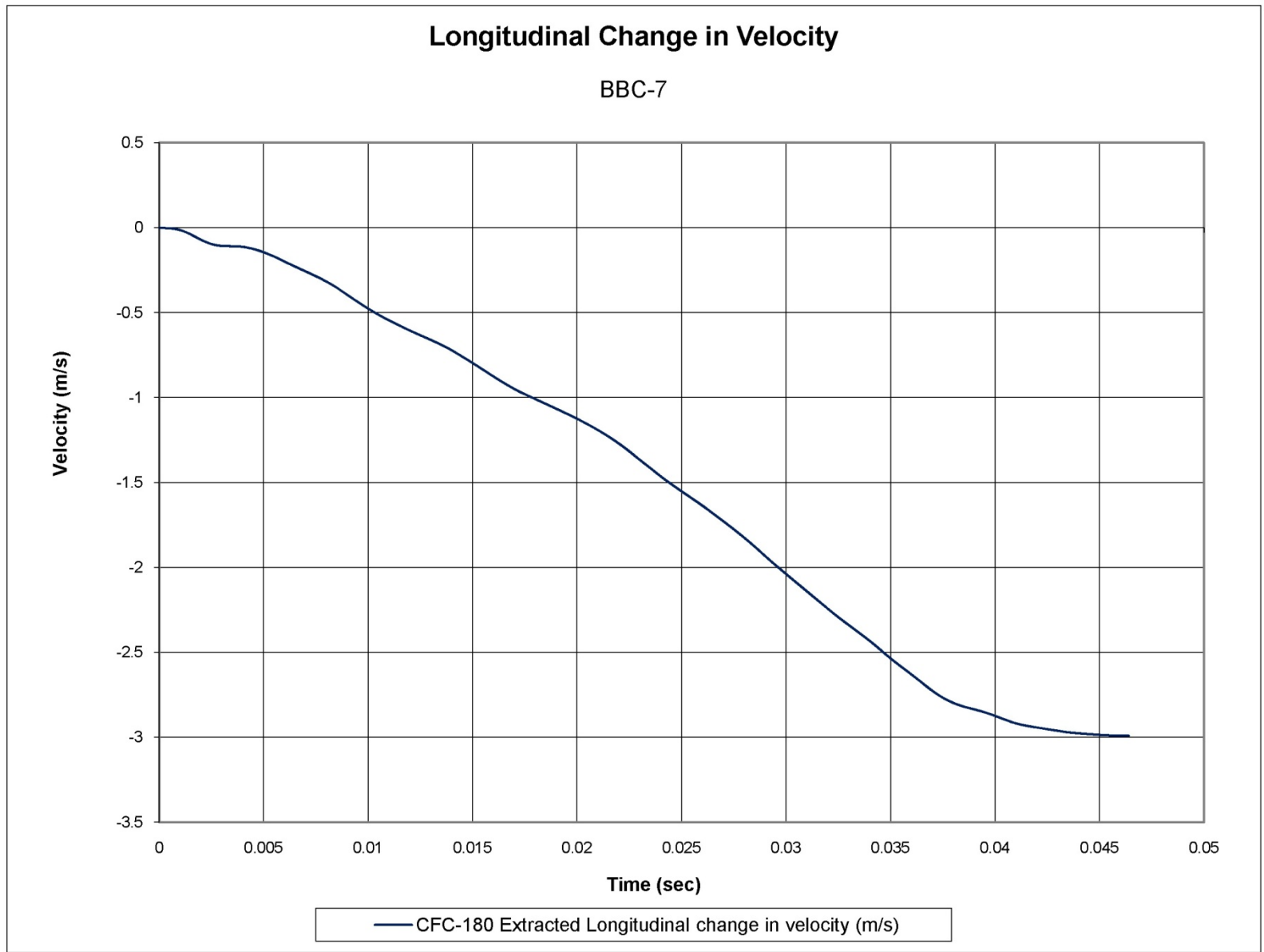

Figure H-2. Longitudinal Change in Velocity (DTS-BF57H), Test No. BBC-7

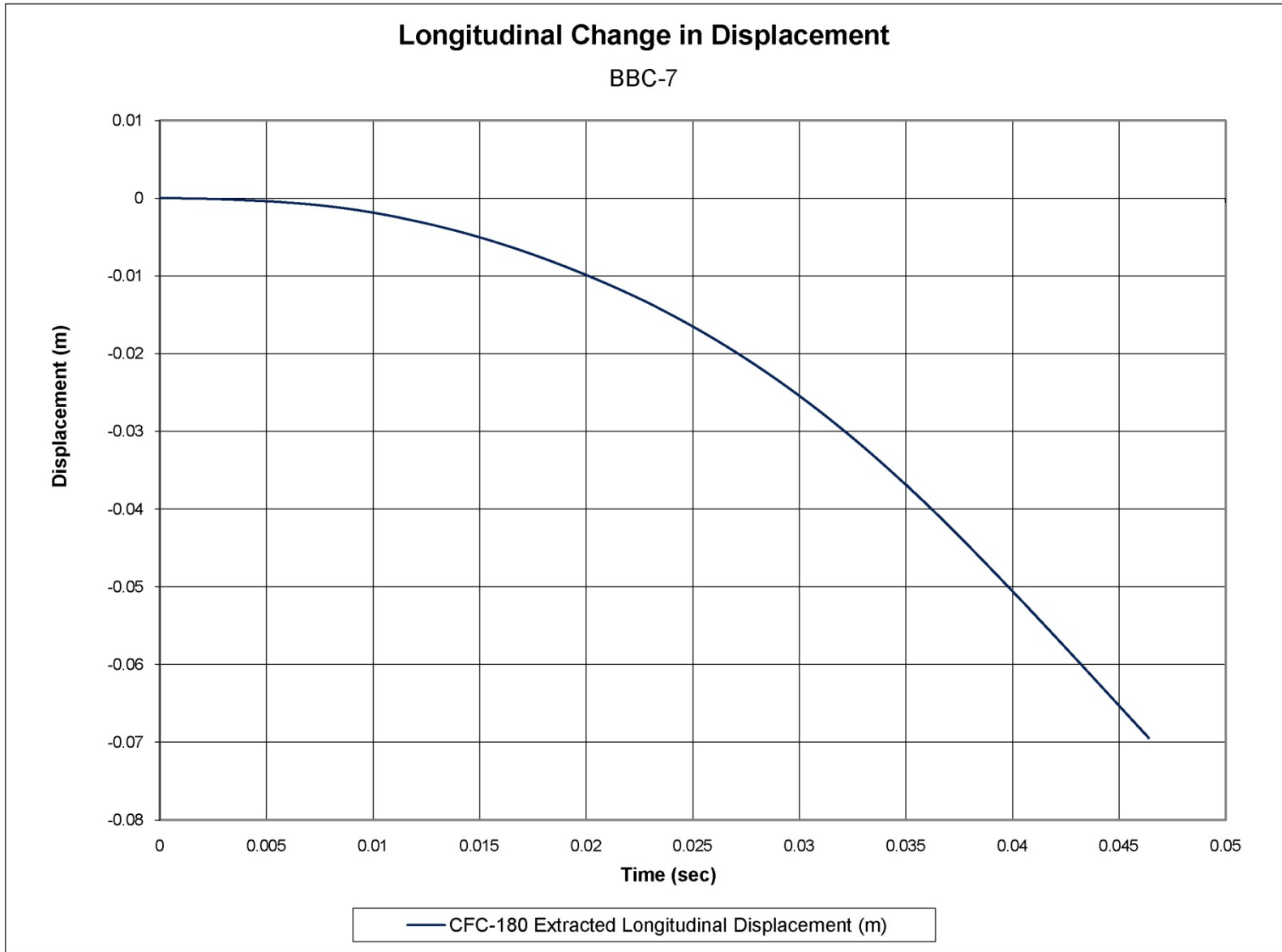

Figure H-3. Longitudinal Change in Displacement (DTS-BF57H), Test No. BBC-7

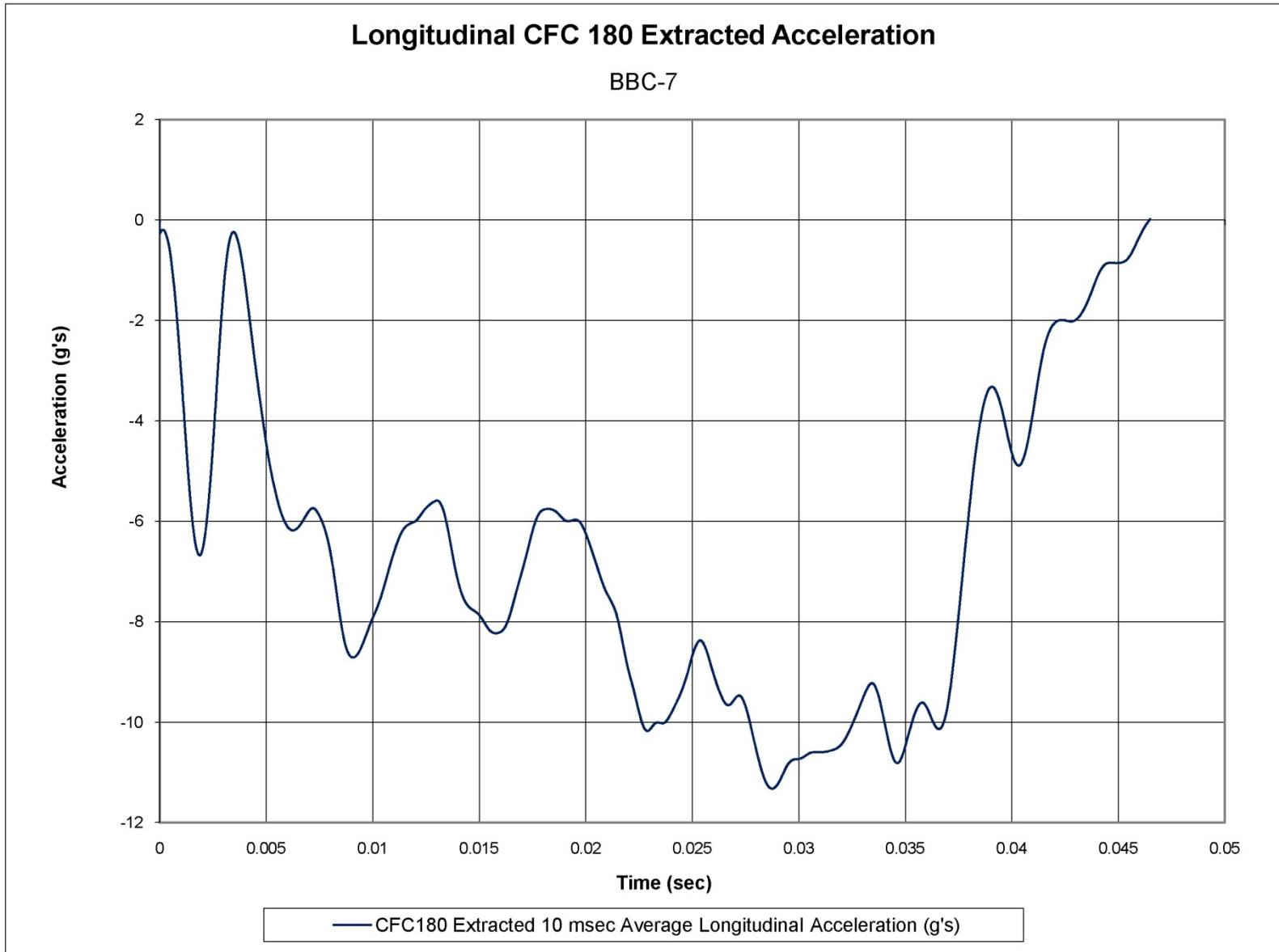

Figure H-4. Longitudinal Deceleration (DTS-CM54H), Test No. BBC-7

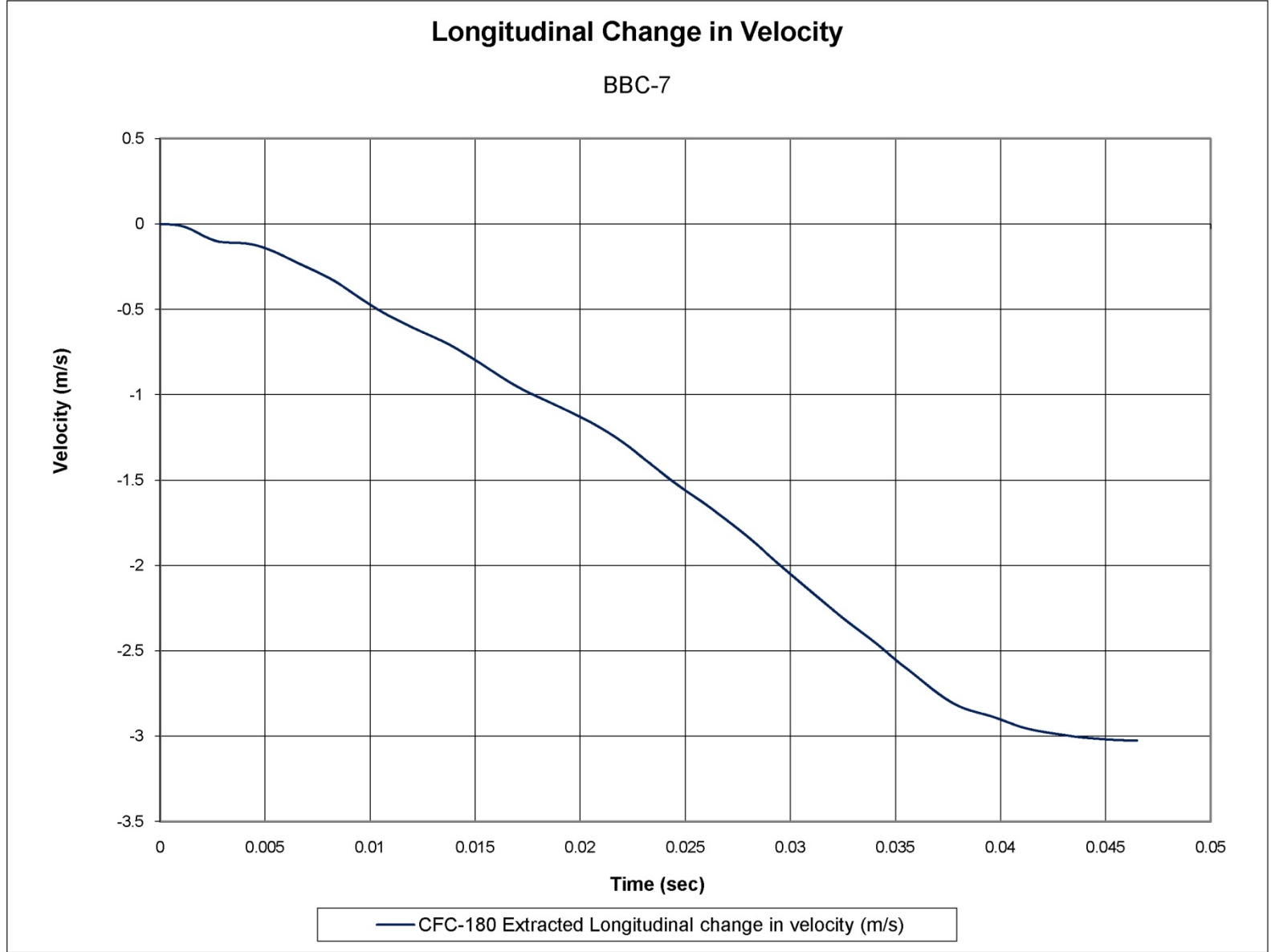

Figure H-5. Longitudinal Change in Velocity (DTS-CM54H), Test No. BBC-7

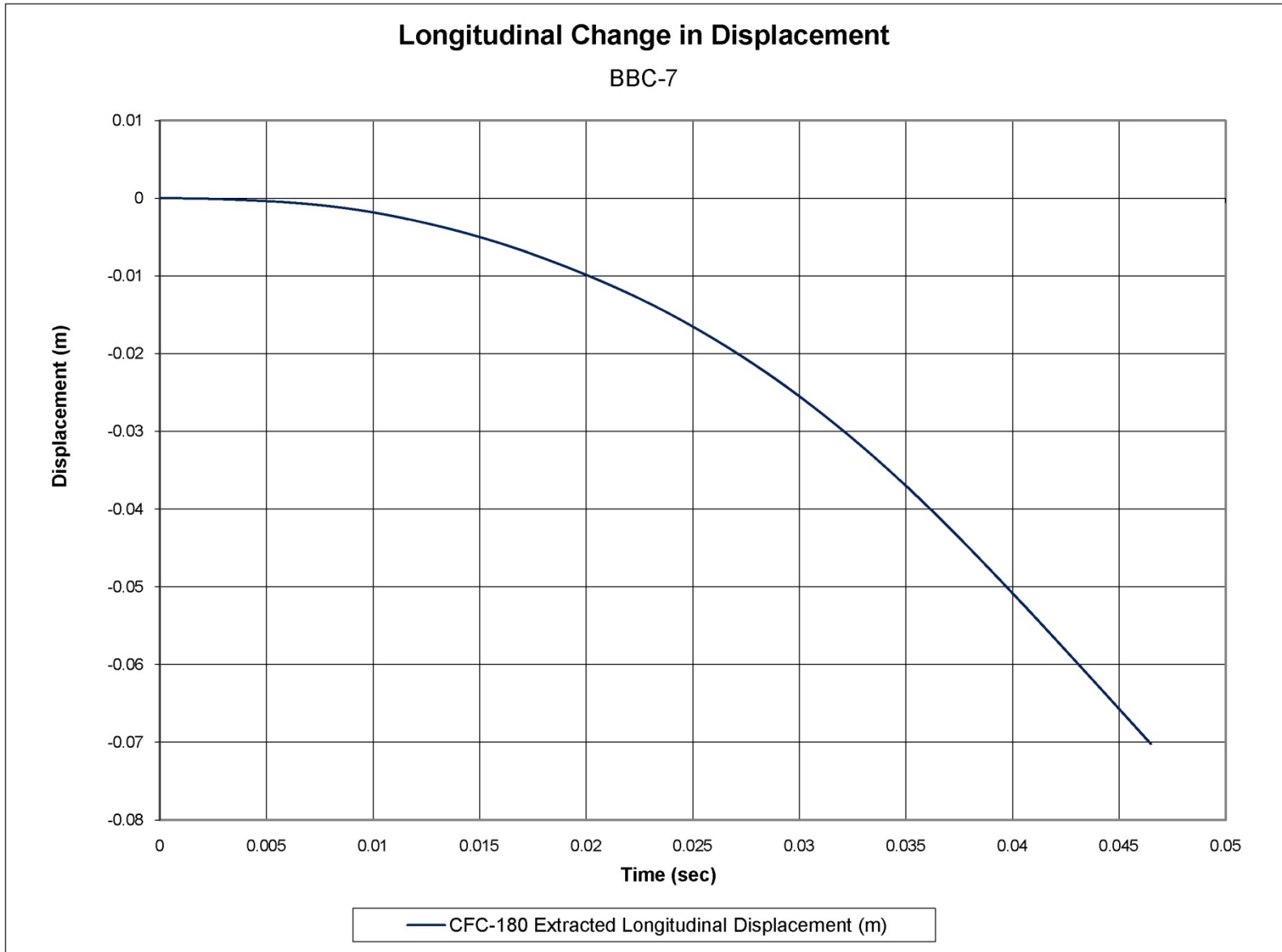

Figure H-6. Longitudinal Change in Displacement (DTS-CM54H), Test No. BBC-7

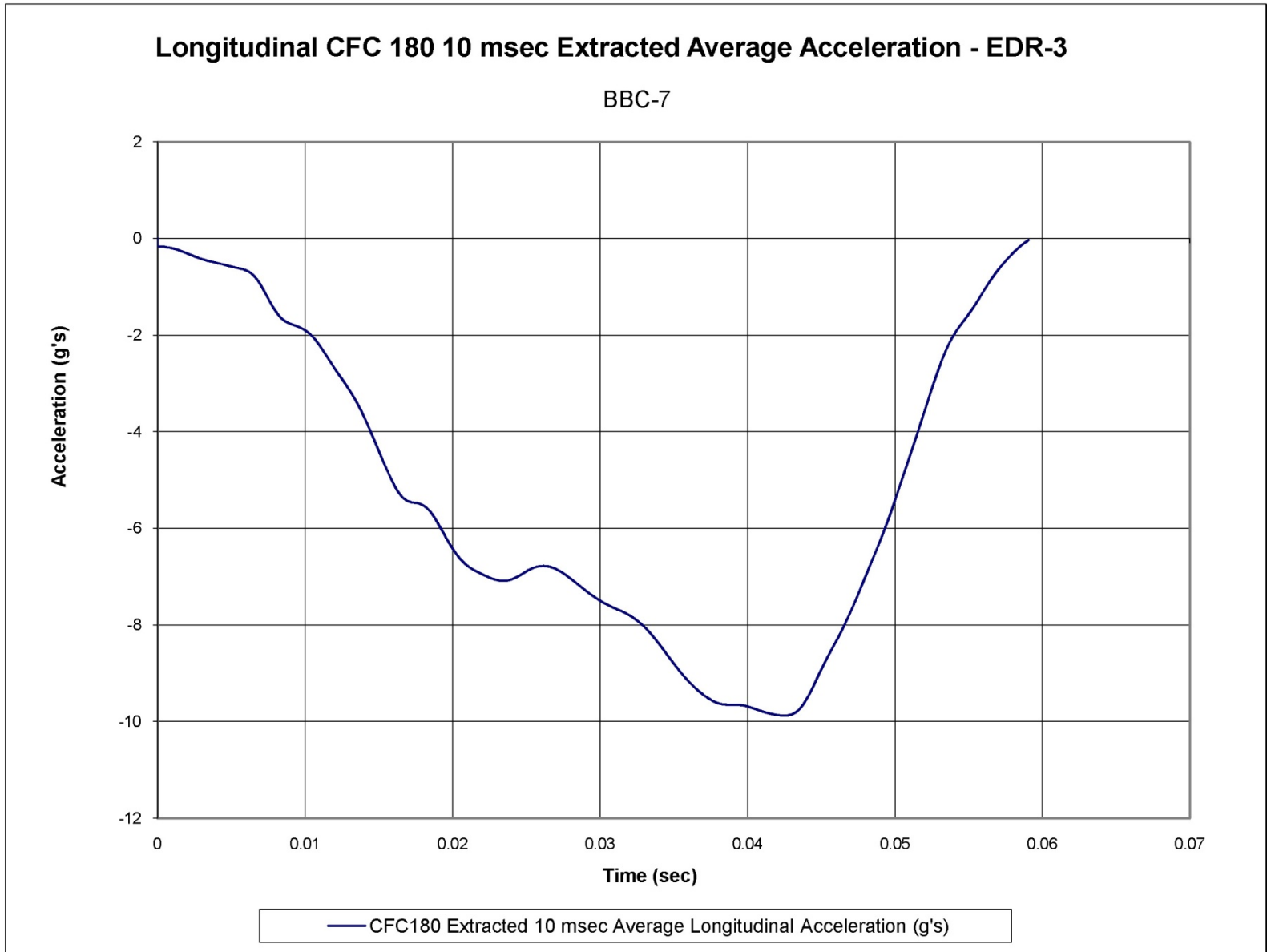

Figure H-7. Longitudinal Deceleration (EDR-3), Test No. BBC-7

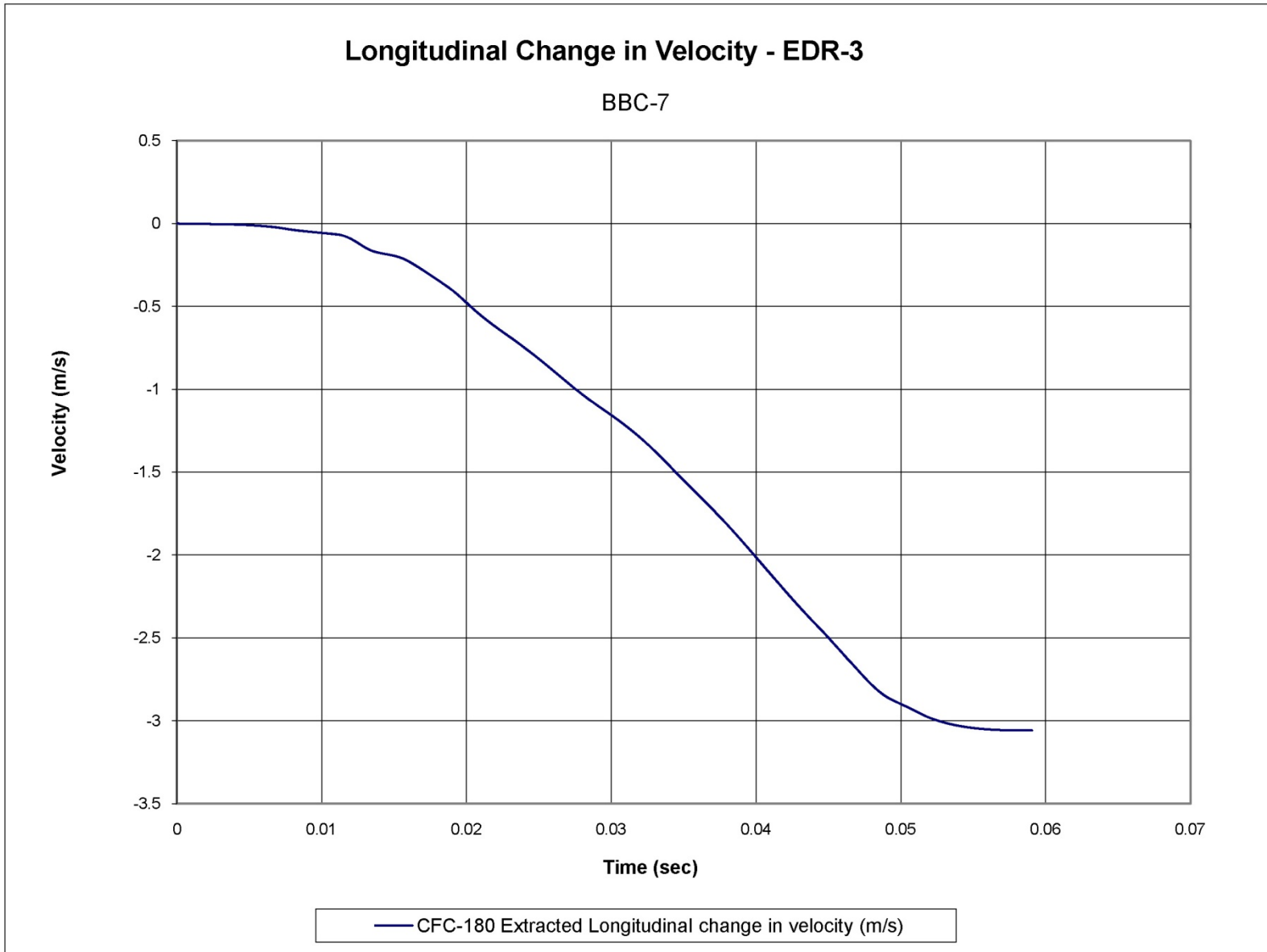
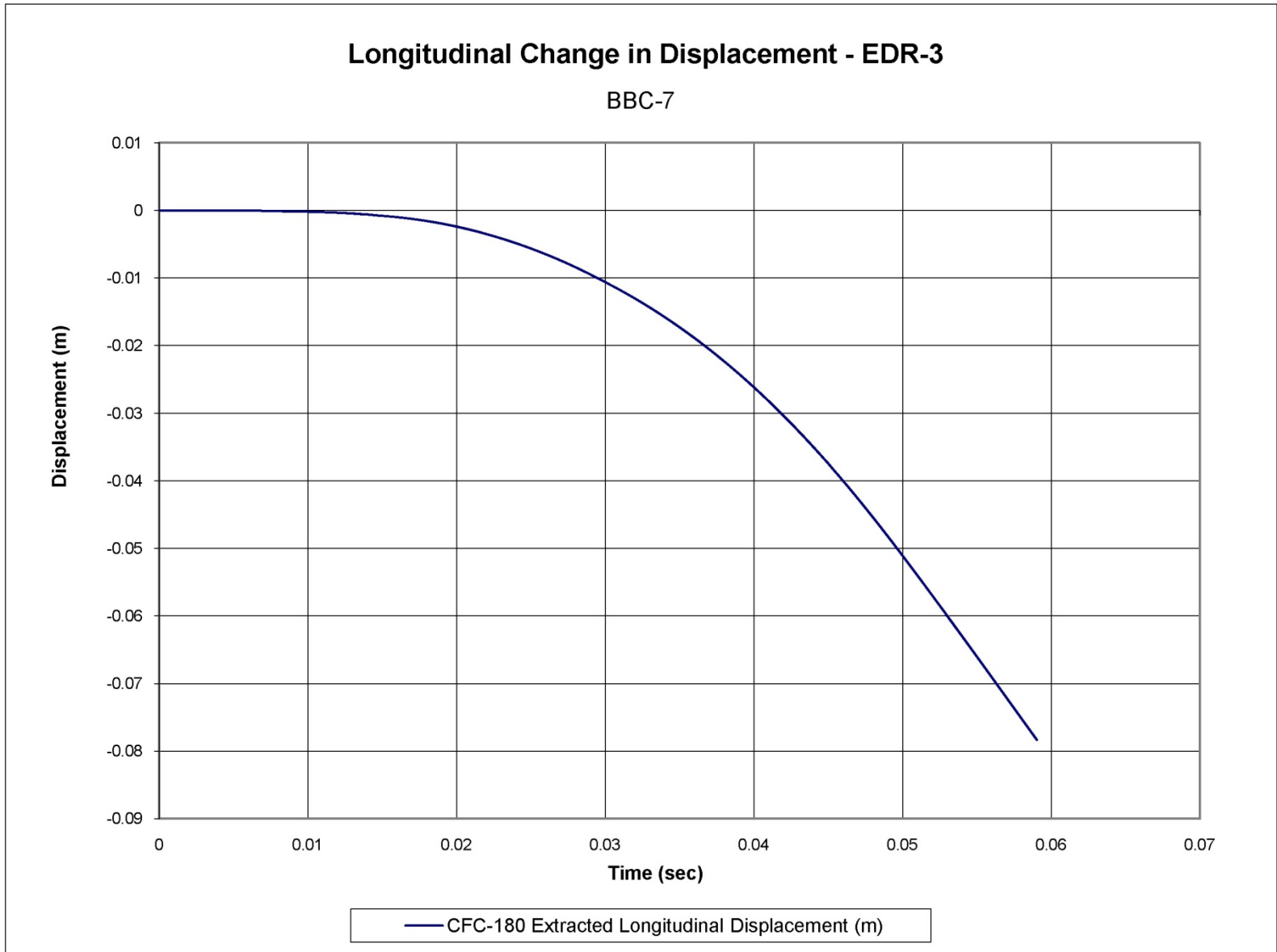

Figure H-8. Longitudinal Change in Velocity (EDR-3), Test No. BBC-7



Longitudinal Change in Displacement (EDR-3), Test No. BBC-7

END OF DOCUMENT