



Strathprints Institutional Repository

McIntyre, Stuart and Fawcett, Travis and Dickinson, Thomas and West, Michael and Maddock, Christie Alisa and Mogavero, Alessandro and Ricciardi, Lorenzo and Toso, Federico and Kontis, Konstantinos and Lo, Kin Hing and Rengarajan, Sriram and Evans, David and Milne, Andy and Feast, Simon (2016) A commercially driven design approach to UK future small payload launch systems. In: 14th Reinventing Space Conference, 2016-10-24 - 2016-10-27, Royal Society. ,

This version is available at <http://strathprints.strath.ac.uk/59885/>

Strathprints is designed to allow users to access the research output of the University of Strathclyde. Unless otherwise explicitly stated on the manuscript, Copyright © and Moral Rights for the papers on this site are retained by the individual authors and/or other copyright owners. Please check the manuscript for details of any other licences that may have been applied. You may not engage in further distribution of the material for any profitmaking activities or any commercial gain. You may freely distribute both the url (<http://strathprints.strath.ac.uk/>) and the content of this paper for research or private study, educational, or not-for-profit purposes without prior permission or charge.

Any correspondence concerning this service should be sent to Strathprints administrator: strathprints@strath.ac.uk

A commercially driven design approach to UK future small payload launch systems

Stuart McIntyre^{*}, Travis Fawcett[†], Thomas Dickinson
Orbital Access Limited, Prestwick International Airport, Prestwick, KA9 2RW

Michael West[‡]
BAE Systems Regional Aircraft, Prestwick International Airport, Prestwick, KA9 2RW

Christie Alisa Maddock[§], Alessandro Mogavero^{**}, Lorenzo Ricciardi^{**}, Federico Toso^{**}
Centre for Future Air-Space Transportation Technology
University of Strathclyde, Glasgow, G1 1XJ, United Kingdom

Konstantinos Kontis^{††}, Kin Hing Lo^{**}, Sriram Rengarajan^{**}
Aerospace Sciences, College of Science and Engineering, University of Glasgow
University Avenue, Glasgow G12 8QQ, United Kingdom

David Evans^{‡‡}, Andy Milne^{§§}
Fluid Gravity Engineering Ltd
83 Market Street, Saint Andrews, KY16 9NX, United Kingdom

Simon Feast^{***}
Reaction Engines Limited
Building F5 Culham Science Centre Abingdon Oxon OX14 3DB, United Kingdom

Abstract

Miniaturisation of satellite componentry, increasingly capable small sensors and substantial increases in processing capacity and transmission bandwidth are driving rapid growth in small payload development and consequential launch demand. The advent of horizontal take-off spaceports opens the door for a new generation of small payload launch systems that will fulfil this demand. However, the key to a launch system's success is its ability to provide a return on the substantial costs of development while delivering pricing levels commensurate with the needs of launch customers. Therefore, commercially led design approaches are needed to refine and optimise the design of the new small payload launch systems required. This approach was embodied in an ongoing UKSA funded NSTP2 project titled Future UK Small Payload Launcher (FSPL^{UK}).

The approach is first founded upon a bespoke and specific market assessment. This characterises, segments and quantifies the commercial opportunity and establishes principal desired system performance requirements. An assessment of available technologies at differing TRLs permits initial vehicle configuration options to be developed and technically assessed. Technically viable options are then assessed in terms of commercial viability with the best advanced into more detailed technical assessment and system optimisation. The resultant vehicles are again tested for commercial viability and, if successful, emerge as recommended development avenues.

^{*} Chief Executive Officer, Email: smcintyre@orbital-access.com

[†] Analyst

[‡] Chief Aerodynamicist, Email: Michael.West@baesystems.com

[§] Lecturer, Centre for Future-Air Space Transportation Technology, Email: christie.maddock@strath.ac.uk

^{**} Research Fellow

^{††} Mechan Chair of Engineering, Professor of Aerospace Engineering, Email: Kostas.Kontis@glasgow.ac.uk

^{‡‡} Project Manager, Email: david.evans@fluidgravity.co.uk

^{§§} Senior Scientist

^{***} Head of Future Projects, Email: Simon.Feast@reactionengines.co.uk

Using these methods, it has been possible to iterate design concepts from apparently simple yet economically sub-optimised stacked launcher systems through several design iterations to a resultant highly flexible and economically efficient conceptual design. The key finding relates to the inter-relationship between payload flexibility, in permitting maximised flight rates from a reasonably complex but highly reusable first stage design, and low disposable upper stage unit cost. This has driven the resultant system to feature an air launched integrated re-usable first stage vehicle, configured with a flexible internal payload bay from which one or more upper stages are deployed. This configuration maximises commercial utility and reusability. The resultant high flight rate allows development costs to be efficiently amortised with minimised direct launch costs. The configuration therefore meets low cost per kg price targets while delivering a positive return on development expenditure over life. It also provides a flight proven vehicle platform with available internal real-estate for application as a hypersonic air test platform for new propulsion systems, such as SABRE. The commercially led approach has created the foundation for viable and economically justifiable development.



Figure 1 - FSPL^{UK} Configuration - Artists Impression at release from carrier

Keywords: Small Payload Satellite Market, Launch Vehicles

**ACRONYMS &
ABBREVIATIONS**

CofG	Centre of Gravity	SSO	Sun Synchronous Orbit
COTS	Commercial Off-The-Shelf	SSTL	Surrey Satellite Technologies Limited
FAA	Federal Aviation Agency	STFC	Science and Technology Facilities Council (UK)
FCS	Flight Control System	TPS	Thermal Protection System
GDP	Gross Domestic Product	TRL	Technology Readiness Level
ISS	International Space Station	TSTO	Two Stage to Orbit
ITAR	International Traffic in Arms Regulations	UAV	Unmanned Air Vehicle
LE	Leading Edge	UKSA	United Kingdom Space Agency
LEO	Low Earth Orbit	UN	United Nations
LOX	Liquid Oxygen		
MTCR	Missile Technology Control Regime		
REL	Reaction Engines Limited		
SABRE	Synergetic Air Breathing Rocket Engine		

FSPL^{UK} Work Programme

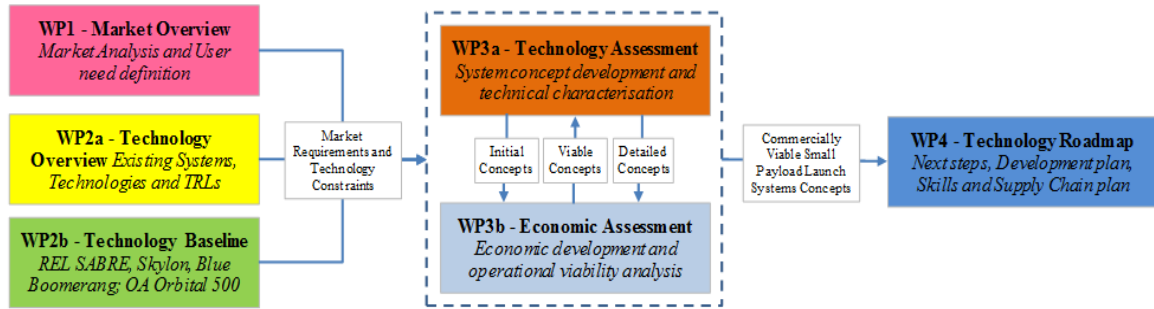

1 INTRODUCTION

Cost effective UK designed, manufactured and operated small payload launch vehicles are desirable to secure the industrial, economic and technological dividend created by the vision of integrated UK satellite design, manufacture and launch from proposed UK and international horizontal take-off spaceports. Space vehicle designs are also required to support the advancing SABRE engine development programme and establish the pathway to the first commercial SABRE powered vehicles. However, such developments are expensive. To justify the investment, it is important that the resultant systems yield sufficient commercial returns over life to not only recoup the investment but also provide satisfactory investor returns.

To achieve this, a commercially driven design approach was developed by a team led by Orbital Access Limited in Prestwick and comprising technical partners, BAE Systems Regional Aircraft Limited, Reaction Engines Limited, Fluid Gravity Engineering Limited, and the Universities of Glasgow and Strathclyde, alongside commercial and customer partners STFC RAL, SSTL and Clyde Space. This paper sets out the principal approach taken and references work and interim outputs from the ongoing commercially-focused FSPL^{UK} study aimed at producing a roadmap for future UK designed, manufactured and operated small payload launchers.

The commercial focus of the project was enabled by a detailed and bespoke assessment of the historical small payload market and an analysis of the market forces that were considered as driving the size and shape of the market in the period of interest (to 2036). This analysis allowed principal market requirements to be established. This guided the technical programme in terms of vehicle performance requirements necessary to maximise

market capture and achieve pricing targets. This was then complemented with a market share analysis that assessed the evolution of the competitive landscape, yielding an expectation of launch rate for the vehicle concepts envisioned in the roadmap.

The result led to a technological roadmap that identifies sequential system developments able to provide ongoing commercial returns while also meeting strategic technological goals. It therefore highlights the near-term opportunity for a successful UK-based commercial small payload launch system development programme.



2 MARKET ANALYSIS

In order to provide the foundation for a commercially led design approach it is imperative to characterise the market opportunity in a manner specifically relevant to the project. While many datasets and forecast outputs may exist these are likely to have been created for different specific purposes or in a generic manner and therefore are likely to provide an incomplete or inconsistent perspective for the new study topic. Hence, invariably, a commercially led design approach must begin with a detailed market study to provide the specifically relevant and understood market context.

In the case of the FSPL^{UK} project, the small payload market has been the subject of various analyses and forecasts in recent years. However, these have been conducted with specific constraints in either period or scope and have applied underlying methodologies and judgements which are undisclosed or unclear.

In order to assess the commercial opportunity for the launcher concepts to be assessed in the study it was necessary to perform a correctly scoped market study and forecast future launch demand volume and shape based known methodologies and judgements. In this way the levels of uncertainty and risk attributable to conclusions informed by the forecast would be able to be determined and accounted for in assessing the study and its proposals.

2.1 MARKET FORCES METHOD

A variety of forecasting methodologies can be considered and the selection will depend upon the specific objective. In the case of small space payloads, the immaturity of the market, combined with a highly fluid technological environment makes traditional formulaic forecasting problematic. Because of the range of variables, a “market forces” approach was utilised as the principal basis for the forecast.

This involved the compilation and verification of a comprehensive historical payload and launch database. This allowed for detailed segmentation of historical launch and payload activity by payload mass category, orbit altitude and inclination. It also gave clarity on historical launch providers and the nature of the existing market in terms of primary and secondary payload proportions.

2.2 HISTORICAL ANALYSIS

The historical data demonstrates the sharp growth emerging in the number of small payloads being launched.

The data also evidences the dependency on secondary rideshare capacity to launch these payloads. Furthermore, it identifies the significant proportion of the market that has historically been launch capacity led, especially, the predominance of payloads going to ISS orbits on the back of ISS resupply capacity (Mahoney, 2016).

The data identifies successful or unsuccessful launches and defines a failure rate of 4% (1 in 25) between 2012 and 2016.

The data also reveals the demonstrable risk to the small payload development industry associated with the concentration of payloads on a few large capacity launches. It also shows the impact on small payloads launched in 2015 due to the unavailability of the Antares system following the failure in 2014 (Bergin, 2014).

The market pricing for launch was also characterised in terms of disclosed launch pricing, published

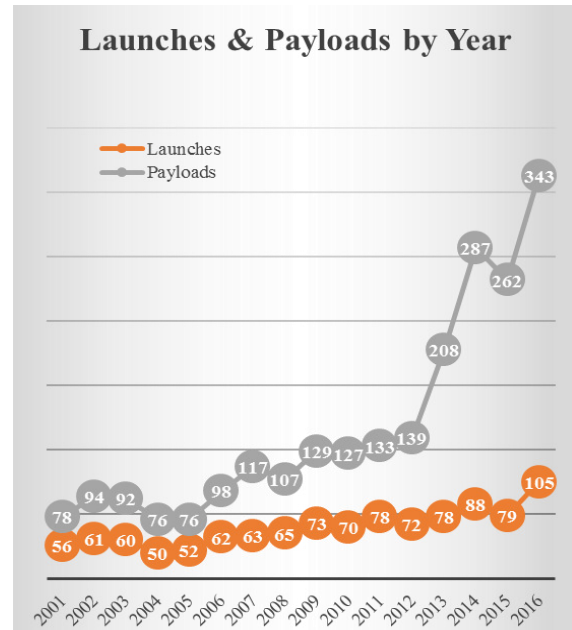

Figure 2- Annual Launches and Payloads 2001 to 2016

pricelists and inputs from established satellite manufacturers.

2.3 FORECAST

A market forces approach requires the principal forces acting upon the market to be researched and characterised in terms of their impact on growth and/or shape and distribution of demand in the market (Rubinfeld, 1998). For the FSPL^{UK} project, in assessing the future growth in demand for small payload launch, the following market forces and strategic factors were considered:

- **Miniaturisation** - The innovation in satellite technologies; which led to the CubeSat configurations, component miniaturisation, subsystem efficiencies, thermal control architecture, data transfer rates, service life, structural reliability, sensors, power supply and on-board propulsion. This ongoing trend underpins growth in small payload spacecraft development with an increasing focus on higher levels of capability and therefore commercial (as opposed to academic) focus. In turn, this also leads to a trend toward higher LEO altitudes to prolong commercial service life.
- **Satellite Applications** – Analysis was conducted of emerging new applications and a segmentation of sub-applications in order to predict the establishment and destination of new satellite

constellations and directly inserted payloads; regarding altitude and inclination. This assessment identifies likely growing predominance of earth observation platforms seeking higher inclination launches and sun synchronous orbits as well as the emergence of mega constellations providing space-based global communications and data transmission capabilities.

- Economic Growth vs Space Sector Growth** – Historical growth in the space sector is founded on underlying global GDP growth. Historical data demonstrates that space sector growth is outstripping global GDP growth and national growth in space industrial economies. Analysis of these differential growth rates provides a baseline for anticipated underlying economic growth in the space sector in the future and is therefore utilised in forecasting future market volumes.
- Regulatory Regimes** – The regulatory environment can dictate, enable or constrain the direction and shape of the market. This environment includes regulations and treaties such as ITAR, MTCR (MTCR, 2016), UN (UNOOSA, 2016) and the United Kingdom Space Act (Crown Copyright, 1986). Increasingly national space agencies and Governments are defining the regulatory environments they intend to both promote and control the development of their space sectors. This assessment identifies that large launch capacity development is likely to be tightly confined to existing nations with such capabilities and within existing programs. New commercial launch vehicle development is likely to be principally enabled and promoted within the small payload (sub 500 kg) capacity sector.
- Small Payload Launch Capacity** - The introduction of small payload launchers will change how satellite manufacturers will choose a launch system; this is an important area to understand and monitor. Currently, due to the lack of feasible and available small payload launchers, there is a substantial risk of concentration for small payloads as rideshare on large launches. This has consequential risks leading to insurance and finance costs that constrain demand. This is exacerbated by prolonged and often uncertain lead times to launch which pressurises business cases and finance. The advent of frequent, responsive, more financially attractive and lower risk launch

Baseline Forecast Highlights

- Underlying annual growth declining from 3.6% (The World Bank, 2016) pa to 3.0% pa by 2036 reflecting space sector growth increment to GDP growth reducing over time.
- Congestion depresses growth in Pico to Micro sectors from 2032.
- New upperstage propulsion technologies drive second growth phase in Pico to Mini class from 2028
- Advent of new constellations underpins growth within the Pico to Micro sectors from 2019 with shift in focus to high inclination and altitude orbits, (Airbus DS GmbH, 2015).
- Market size in 2016 is 343 payloads with a total mass of 430,835 kg
- Total market reaches 2,753 payloads by 2036 with a total mass of 1,152,751 kg
- Average payload mass declines from 1,146 kg in 2016 to 419 kg by 2036.

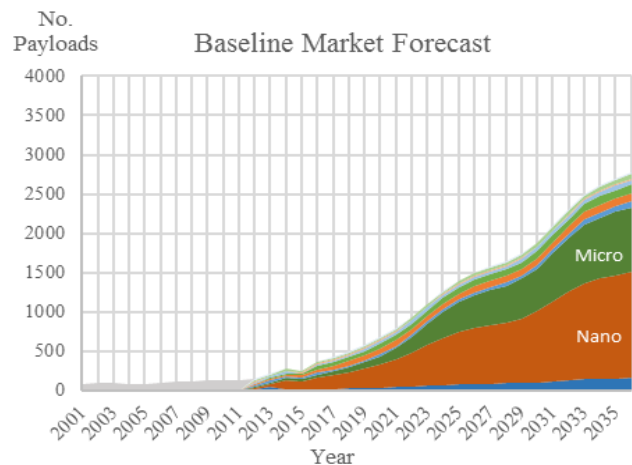

Figure 3 - Future baseline forecast on the volume of payloads per year, segmented by mass

opportunities will underpin growth in the small payload sector.

- ISS and Large Launch Future Direction** - The destination (e.g. ISS) of large primary payloads dictates the destination of the associated secondary payloads. ISS resupply has been shown to be a dominant force shaping historical small payload launch predominance. However, the possible retirement date for the ISS in 2024 (Timmer, 2014) and the increasing focus of large launch to exploration and resource acquisition missions may result in a progressive decline in large launch rideshare capacity. This will

constrain growth in scenarios where small payload launcher capacity is insufficient to meet demand. It will also result in optimised small payload missions seeking the specific orbits (inclination and altitude) their missions require.

An analysis of these market variables was conducted alongside inputs of research and comparative work

Vehicle Requirements Definition

- Air Launch utilising modified DC10 / MD11 carrier aircraft platform.
- Re-usable fly-back first stage.
- Nominal mission, 500 kg payload to 650 km circular LEO at 88.2 deg inclination (3 x OneWeb satellites to OneWeb parking orbit) (Selding, 2014)
- Extended mission, 150 kg payload to 1200 km circular LEO at 88.2 deg inclination (OneWeb operational orbit) (Selding, 2014)
- Reference launch location- carrier aircraft take-off from Prestwick with air drop location near west of Hebrides
- Price target \$30,000 per kg

from industry experts and satellite manufacturers.

Using this, a multi-variate forecast model was created to predict the number of payloads that will be launched yearly from 2016 to 2036. Using the contextual research of market forces and industrial factors; the forecast detailed the volume of payloads that fell into each FAA Weight Classification (including Pico-Mini). It also predicted the evolving demand within each weight class for particular orbit inclination and altitudes.

Three perspectives were generated for the output of this forecast; a “Potential” volume model was created based on assumptions of continuing strong growth with minimum constraining forces. A “Pessimistic” model was then created which downplays the emergence of large scale constellations and relies on conservative ongoing growth rates for small payload demand. Between these a “Baseline” model was generated that reflects a balance of positive growth drivers and constraining effects. This model was then used as the baseline for the assessment of the launch vehicle configurations developed (see Figure 3).

2.4 MARKET REQUIREMENTS

A commercial design approach naturally links the requirements specification to the areas of the market where greatest commercial opportunity exists and thereby steers the development of vehicle configurations to maximise market capture and value.

In the case of the FSPL^{UK} project a significant portion of the potential future market is based on small commercial payloads, especially for large volume constellations, around the 125kg to 150kg size. With a maximum price per kg of \$30,000 economies of scale require to be harnessed. However max payload needed to be limited to 500kg or below to avoid automatic MTCR Category 1 classification (MTCR, 2016). The forecast also identified that smaller commercial payloads would increasingly seek high altitude operations to maximise in orbit-life and that the predominance of high altitude sun-synchronous orbits would increase. These factors drove vehicle requirements to look at larger capacity systems at the upper end of the sub 500kg range with high altitude and high inclination performance. As payload physical size was also a consideration these factors allowed a simple commercial requirement characterisation to emerge.

It was determined to shape the requirement specification to the carriage of three OneWeb class 150 kg payloads to the OneWeb transfer altitude of 650 km and inclination of 88.2 deg (Selding, 2014). A stretch target of deploying a single OneWeb satellite to the direct constellation insertion altitude of 1,200km was also set (Rubinfeld, 1998).

This style of requirements specification was important as it continuously emphasised the commercial focus of the project and provides a practical reference as technical trade-offs are being considered.

2.5 MARKET SHARE

Simultaneous to the volume forecast, the market overview included a market share analysis to give a comprehensive index of existing and upcoming launch systems and provide a perspective of the developing competitive landscape during the period of the forecast. This delivered an attractiveness scale to compare vehicle capability and capacity; which gave substance to a prediction on the number of launches that each vehicle configuration might expect during its service life.

As a conservatism factor, the analysis focussed wholly on the identifiable commercial market and

no consideration was given to adjacent markets, such as military or defence.

3 TECHNICAL DESIGN PROCESS

3.1 CONCEPTUAL DESIGN

As with any complex aerospace system a structured design approach is required. A commercially led approach is no different. Indeed, the perpetual focus on the commercial intent promotes the imperative of a substantive expert design process with reliable, safe functional system performance as the critical output.

Having established system requirements through a structured market assessment the technical phase aims to determine viable conceptual system designs. The FSPL^{UK} project, with its objective of defining a roadmap for a series of vehicles to provide both commercial launch capability and SABRE development, approached this challenge by first assessing the available technologies and their TRLs and the baseline technical data available to the project. This included the baseline DC10/MD11 series carrier aircraft platform as well as the SABRE engine data deck. Conventional rocket propulsion solutions at high TRL were provided by an established propulsion manufacturer.

3.2 ITERATIVE COMMERCIAL AND TECHNICAL EVALUATION

In a commercially led design process, emerging conceptual designs are first technically developed and then assessed from a commercial viability perspective. This process then iterates for the most

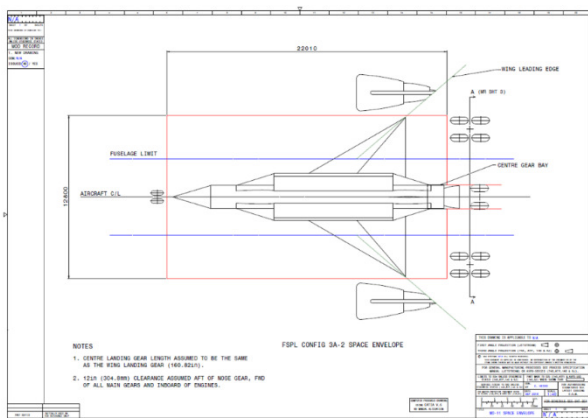

Figure 3 - FSPL^{UK} Configuration demonstrating DC10 carriage envelope

Mass, Trim and Layout

- 6 mass estimation methods (Rohrschreiber) - Conservative mass taken
- Trim analysis undertaken to optimise layout for CofG control
- Trim effected using elements of thrust vectoring and consider use of body flap
- Use of LE strakes to assist aero centre control shifts through transonic region.

Structural Architecture

- Conventional light alloy structural materials
- Spaceframe fuselage with pressurised LOX tanks and conformal RP1 tanks
- Multispar delta wing and fins
- Use made of lightweight composite materials where economically viable

Aerodynamics

- Aerodynamic predictions (C_L and C_D) based on engineering methods and correlations.
- Validation of the methodology against published data for different Mach numbers and incidences;
- Aerodynamic analysis of proposed configurations including peak heat fluxes.

Thermal Protection

- Hypersonic heat flux and temperature models constructed for direct insertion in optimiser code
- TPS sizing estimator to allow dynamic total mass prediction as vehicle and trajectory parameters are varied

Design & Performance Optimisation

- Multidisciplinary design and performance optimisation for vehicle configuration based on nominal end-to-end mission
- Single objective minimising fuel consumption and dry mass based on design variables for each subsystem
- Multi-objective performance optimisation exploring all payload-mission capabilities for each stage and system as a whole

Avionics

- Maximum use of proven COTS equipment
- FCS to be based on military UAV technology

promising designs to arrive at optimum conceptual designs. In the FSPL^{UK} project the technical development engaged the discrete specialisms of the consortium.

BAE Systems led the identification of initial design concepts and applied strict configuration management processes. For each concept, initial design drawings were followed by initial mass estimation and mass distribution analysis. This led to an assessment of C of G behavior between flight phases.

Based on the baseline configuration geometry, an aerodynamic analysis was done by the University of Glasgow to derive the coefficients of lift C_L and drag C_D for varying angles of attack and Mach number while an aerothermal model was developed by Fluid Gravity Engineering to calculate the heat loads and wall temperatures, and to assess the TPS requirements and sizing. Engine data and models were provided by Reaction Engines for their SABRE while high-TRL/COTS engines were used for the rockets. The University of Strathclyde integrated the various vehicle disciplinary and subsystem models into their own multi-objective trajectory optimisation software to evaluate the design trade-offs and performance throughout the entire mission.

3.3 TRAJECTORY OPTIMISATION

Initial low fidelity, computationally fast aerodynamic, aero-thermodynamic, mass and propulsion data is determined for the baseline design concept based on application of scaling factors and engineering judgement to existing vehicles and designs including Skylon / SABRE data supplied by REL and conducting concept level engineering analysis. Initial performance and mission optimisations were performed to assess concept technical viability. These analyses were developed to answer the question: can a launch system be designed to deliver a target payload within the current or projected state of the art? Once a general system approach and configuration was decided, a number of specific technical vehicle design variables were determined in order to develop a more detailed trade-off analysis looking at aerodynamic surface area, dry and wet mass, engine sizing, and TPS selection. This was done by using a multi-disciplinary design optimisation approach, which integrates all the vehicle subsystem models and optimises the design based on the entire mission performance, rather than optimising each subsystem in isolation.

Once the trade-offs were examined, and a vehicle design was fixed, refined higher fidelity aerodynamics, aerothermal, mass and propulsion analyses were conducted by the consortium

members based on their expertise. These higher fidelity models are integrated into the mission optimisation software to first understand if and how this affected the initial design choices, and secondly to assess the range of mission options for the launch system, looking at the different operational modes. For example, different upper stage configurations, single versus multiple payload deployments and different landing sites. Comparisons are made with the system requirements, considering operational

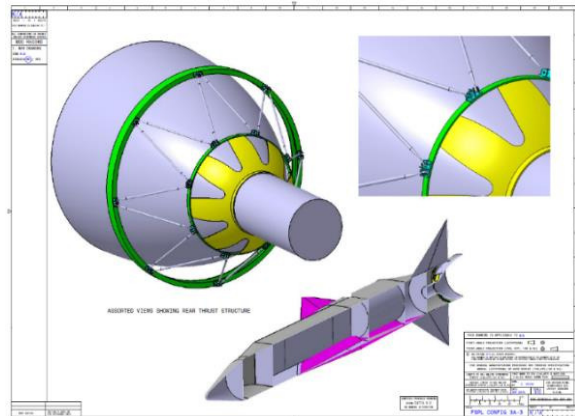

Figure 4 - FSPLUK Configuration 3A-2 Cutaway and Thrust chamber

and cost assessments, and the analysis is repeated as required with different vehicle concepts until a satisfactory solution is identified, or it is concluded that no satisfactory concept has been found.

3.4 COMMERCIAL VIABILITY ANALYSIS

To establish commercial viability, it is necessary to determine whether a positive net margin can be achieved from a vehicle over its lifetime. The project identifies this as the viability quotient (VQ).

$$Viability\ Quotient(VQ) = Total\ Contribution\ over\ Life\ (TC) - Development\ Cost\ (D)$$

where $Total\ Contribution\ over\ Life\ (TC)$
 $= Contribution\ per\ Flight\ (x) * Flights\ per\ Year\ (y) * Service\ Life\ (z)$

and $Contribution\ per\ Flight\ (Cf)$
 $= Gross\ Margin\ per\ Flight\ (GMf) - Overhead\ Allocation\ (OHf)$
 $- Profit\ Levy\ per\ flight\ (PLf)$

Concurrent with the technical assessments the launch system concepts are assessed in terms of their ability to meet the required launch price parameters established by the market requirement analysis. This assessment spans development costs, production costs, operating costs and operating life. It also considers development timelines and time to commercial payback. The analysis computes the contribution that each system will be able to make

towards development costs after considering its revenue potential over life net of the costs of manufacture and operation along with required overhead contribution and profit. Comparing this to the total development cost determines the “Viability Quotient”. A positive viability quotient means that the system should be able to yield an acceptable commercial return on investment and is worthy of proceeding into development. Zero VQ or a negative VQ that is less than the desired profit level will indicate a system that is worthy of further technical analysis and fine tuning to potentially drive it to a positive VQ. A system whose VQ is negative such as to eliminate any profit desired should be considered unfeasible for commercial exploitation and should be rejected unless additional technological or strategic arguments create a valid case for proceeding.

To assess these parameters in the FSPL^{UK} project, the specialist TRANSCOST space system cost estimating package was employed.

The TRANSCOST based analysis demonstrated that positive viability quotients can be achieved through management of key system architecture choices to maximise the available market capture while minimising the cost of disposable elements and maximising the re-use rate of re-usable elements.

3.5 DESIGN PROGRESSION

The starting point design concept for the FSPL^{UK} project was a simple stacked rocket system with a winged returning first stage. Design iterations rapidly progressed to include a fully winged first stage vehicle with an internally stowed payload.

This version presented greater challenges for aerodynamic and TPS elements, but created the prospect for highly flexible payload capability with commensurately wider mission suitability and therefore likely commercial flight rate. Initial low fidelity technical analysis demonstrated the potential for attractive payload performance.

Design iterations on wing and fuselage planform have addressed weaknesses associated with payload bay dimensional needs, stability across the Mach range and constraints associated with the carrier aircraft under fuselage geometry.

The emerging planform is a stepped delta with a broad lifting body fuselage design not dissimilar to the Shuttle orbiter at a small scale and with significantly thinner fuselage cross-section. This design concept continues to be sized to permit internal configurations for the fitment of

development SABRE propulsion for the purposes of air testing. This enables the attractive prospect of a commercially productive reusable small payload first stage vehicle that can be fully flight proven

FSPL^{UK} – Conceptual Design Solution

- One piece delta wing or delta with LE strakes (stepped delta)
- Integral payload bay for upper stages and payloads (parallel multiple stages if required)
- Peripheral tanks arranged singly or in parallel to optimise CG travel during propellant burn.
- Conformal RP1 tanks
- In flight propellant loading for booster and upper stages
- Emergency propellant jettison
- Folding dorsal and ventral fins for carriage and release
- Light weight undercarriage sized for landing booster c/w upper stage and payload (flight abort configuration)
- Fully autonomous flight from release to landing
- Maximum use of COTS components

ahead of application for SABRE air test duties. This ensures that SABRE air test can be carried out with a proven vehicle, and, importantly a vehicle whose principal development cost is amortised through its own commercial productivity under conventional rocket power. Trajectory optimisation and final commercial analysis for this emergent configuration are currently in iteration within the FSPL^{UK} project team.

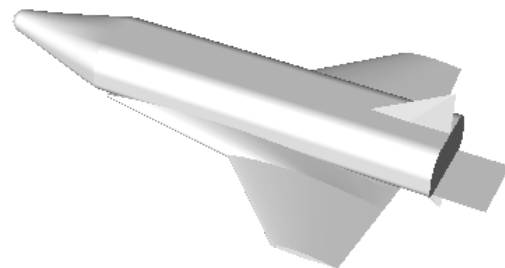

Figure 5 - FSPLUK - Configuration - stepped delta wing

4 CONCLUSIONS

The study highlights the benefits of embarking on a technological design process having first understood the market drivers and dynamics. While the final project outputs await the completion of final design configuration iterations and analysis, the project has identified a clear appreciation of the principal design choices that can lead to commercial viability.

By embarking on the process with the appreciation that launch price per kg is the principal driver of launch uptake, a point emphasised by the projects' internal and external customer references, an economy of scale approach was taken as a principal design choice. This led to a design focus at a larger (rather than smaller) payload capacity. In turn this choice meant that the resultant system can aspire to capture share from the largest launch market possible, while not restricting access to smaller payload categories. The resultant minimised price per kg ensures that market share expectations can also be maximised leading to an enhanced launch rate. The adoption of an air launched architecture, combined with a civilian wide-body transport as a carrier aircraft also underpins the deployability of the resultant system. This ensures that the most flexible customer service can be offered, with the potential for global operations in convenient customer locations and time zones rather than being limited to distant fixed remote launch locations. This concept underpins the scalability of the resultant launch offering and again the prospect of enhanced launch rates. These factors, when combined with a fully reusable first stage system, maximise the potential to amortise development expense and deliver an attractive viability quotient.

The configuration that has emerged also opens up a wide range of potential future mission applications. By creating a payload bay that can be independent in design terms of the upper stage systems deployed from it, a range of further upper stage strategies can be developed depending on the payload objectives or other mission requirements. This might include optimised smaller upper stages for smaller payload missions or multiple upper stages for small constellation deployment. This feature creates further potential to maximise launch rates utilising the first stage architecture and therefore amortise development expense.

Strategically the design direction enables a long term development roadmap that can provide a flight tested airframe to be translated to form a test platform for SABRE. With the SABRE engine

proven and commercially available, the opportunity

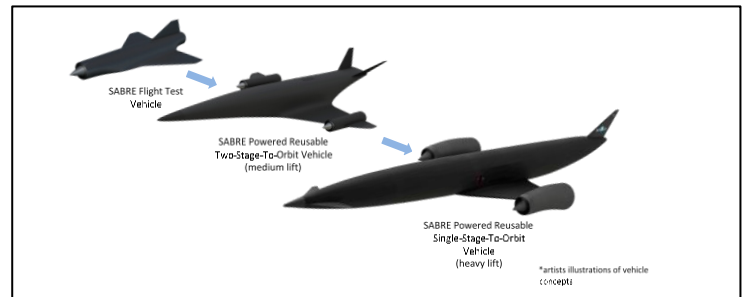

to optimise a TSTO SABRE powered small payload launcher becomes a reality.

ACKNOWLEDGEMENTS

This work was funded by the UKSA National Space Technology Programme (NSTP-2) through the Centre for Earth Observation Instrumentation and Space Technology (CEOI-ST).

REFERENCES

- Airbus DS GmbH, 2015. Airbus Defence and Space Selected to Partner in Production of OneWeb Satellite Constellation. [Online] Available at: <https://airbusdefenceandspace.com/newsroom/news-and-features/airbus-defence-and-space-selected-to-partner-in-production-of-oneweb-satellite-constellation/>
- Bergin, C., 2014. Post mortem for CRS-3 Antares notes turbopump failure. [Online] Available at: <https://www.nasaspaceflight.com/2014/11/post-mortem-for-crs-3-antares-turbopump>
- Crown Copyright, 1986. UK Outer Space Act 1986. [Online] Available at: <http://www.legislation.gov.uk/ukpga/1986/38/introduction>
- Dahlgren, D., 2014. Rocket for ISS explodes on lift-off. [Online] Available at: <http://evertiq.com/news/35507>
- Krebs, G. D., 2016. Amos 6. [Online] Available at: http://space.skyrocket.de/doc_sdat/amos-6.htm
- Krebs, G. D., 2016. Formosat 5. [Online] Available at: http://space.skyrocket.de/doc_sdat/formosat-5.htm

Mahoney, E., 2016. CubeSat Launch Initiative.
[Online] Available at:
http://www.nasa.gov/directorates/heo/home/CubeSats_initiative

MTCR, 2016. MTCR Equipment, Software and Technology Annex.. [Online] Available at:
http://mtcr.info/wordpress/wp-content/uploads/2016/07/MTCR-TEM-Technical_Annex-2016-03-17-Current_Version.pdf.

Rubinfeld, R. P. & D., 1998. Econometric Models and Economic Forecasts. Singapore: Irwin McGraw-Hill.

Selding, P. B. d., 2014. Google-backed Global Broadband Venture Secures Spectrum for Satellite Network. [Online] Available at:
<http://spacenews.com/40736google-backed-global-broadband-venture-secures-spectrum-for-satellite/>

The World Bank, 2016. GDP growth (annual %). [Online] Available at:
<http://data.worldbank.org/indicator/NY.GDP.MKT.P.KD.ZG>

Timmer, J., 2014. Station Funding to 2024. [Online] Available at:
<http://arstechnica.com/science/2014/01/us-to-extend-the-international-space-station-funding-to-2024/>

UNOOSA, 2016. National Space Law Collection. [Online] Available at:
<http://www.unoosa.org/oosa/en/ourwork/spacelaw/nationalspacelaw/index.html>