



## Damping torque analysis of virtual inertia control for DFIG-based wind turbines

Lv, C., Littler, T., & Du, W. (2015). Damping torque analysis of virtual inertia control for DFIG-based wind turbines. In 5th International Conference on Electric Utility Deregulation and Restructuring and Power Technologies (DRPT 2015). IEEE . DOI: 10.1109/DRPT.2015.7432565

### Published in:

5th International Conference on Electric Utility Deregulation and Restructuring and Power Technologies (DRPT 2015)

### Document Version:

Peer reviewed version

### Queen's University Belfast - Research Portal:

[Link to publication record in Queen's University Belfast Research Portal](#)

### General rights

Copyright for the publications made accessible via the Queen's University Belfast Research Portal is retained by the author(s) and / or other copyright owners and it is a condition of accessing these publications that users recognise and abide by the legal requirements associated with these rights.

### Take down policy

The Research Portal is Queen's institutional repository that provides access to Queen's research output. Every effort has been made to ensure that content in the Research Portal does not infringe any person's rights, or applicable UK laws. If you discover content in the Research Portal that you believe breaches copyright or violates any law, please contact [openaccess@qub.ac.uk](mailto:openaccess@qub.ac.uk).

# DAMPING TORQUE ANALYSIS OF VIRTUAL INERTIA CONTROL FOR DFIG-BASED WIND TURBINES

*C. Lv\**, *W. Du<sup>†</sup>*, *T. Littler\**,

*\*Queen's University Belfast, UK*

*clv01@qub.ac.uk; t.littler@ee.qub.ac.uk*

*†North China Electric Power University, Beijing, China*

**Keywords:** Variable speed wind turbine, doubly-fed induction generator, low-frequency oscillations, damping torque analysis, power system stability.

## Abstract

The increasing penetration of large-scale wind generation in power systems will challenge the power system inertia due to the reason that the converter based variable speed wind turbines have no contribution to the system inertia. Traditionally, a doubly fed induction generator (DFIG)-based wind power plant naturally does not provide frequency response because of the decoupling between the output power and the frequency. Moreover, DFIGs also lack power reserve margin because of the maximum power point tracking (MPPT) operation. In this paper, a virtual inertial control strategy of the DFIG based wind turbines called supplementary control loop for inertial response is investigated. When the system frequency is changing severely, the output power of DFIG should respond to it rapidly through the virtual inertial controller at the same time. The rotor speeds of wind turbines can also be adjusted into this procedure. The inertial control methods proposed in this paper can supply controllable virtual inertia of DFIGs to the power system so that the system frequency stability can be strengthened through inertial control of wind turbines on the basis of damping torque analysis.

## 1 Introduction

As the renewable sources of energy are increasingly promoted by the electricity industry, the fossil plants are gradually being retired at the same time. Wind power is one of the emerging renewable energy technologies with fastest growing speed and has been widely utilized in power systems. The kinetic energy of the spinning inertia of the retired turbine-alternators is no longer there to support the frequency stability in the event of outage or a sudden large increase in system demand [1].

Wind turbine generators (WTGs) can be divided into two basic categories: fixed speed WTGs and variable speed WTGs. A fixed speed WTG generally uses a squirrel-cage induction generator to convert the mechanical energy from the wind turbine into electrical energy. There is a strong

coupling between the squirrel-cage induction generator stator and the power system, any deviations in system speed will result in a change in rotational speed [2]. Variable-speed WTGs can offer an increased efficiency in capturing the energy from wind over a wide range of wind speed, along with better power quality and the ability to regulate the power factor, by either consuming or producing reactive power. Double fed induction generator (DFIG) is one popular type of variable speed WTGs. DFIG penetration could reduce system inertia and affect frequency responses only if when it replaces conventional synchronous generation. Otherwise, it has negligible effect on system speed regulation [3]. This is due to the fact that the DFIG control system decouples the mechanical and electrical systems, thus preventing the generator from responding to system frequency deviations [4].

A possible solution to the lack of DFIG wind turbine inertial response is through the addition of a supplementary control loop to provide an inertial response which is similar to a conventional synchronous generator [5]. Similar to conventional generators, wind turbines have a significant of kinetic energy stored in the rotating mass of their blades. Variable speed wind turbines are able to support primary frequency control and to emulate inertia by applying additional control loops. The kinetic energy stores in the "hidden inertia" of the turbine blades [6].

In this paper, a classical virtual inertial control strategy of DFIG based wind turbines called supplementary control loop for inertia response is investigated. When the system frequency is changing severely, the output power of DFIG should respond to it rapidly through the virtual inertial controller at the same time. The rotor speed of wind turbines can also be adjusted into this procedure. The inertial control methods proposed in this paper can supply controllable virtual inertia of DFIGs to the power system so that the system frequency stability can be strengthened through inertial control of wind turbines on the basis of damping torque analysis. The proposed approach also shows that while virtual inertia is not incorporated directly in long-term frequency and power regulation, it may enhance the system steady-state behaviour indirectly. A time domain simulation is used to verify the results of the analytical studies.

## 2 Modelling of power system

## 2.1 A simplified model of DFIG-based wind turbine

Fig.1 shows a single-machine infinite-bus power system with a DFIG-based wind turbine connected.

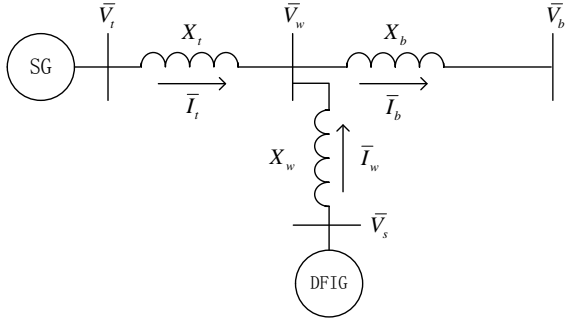

Figure 1: SMIB power system with DFIG wind turbine connected)

The four order equations of synchronous generator are:

$$\begin{aligned} \dot{\delta} &= \omega_0(\omega - 1) \\ \dot{\omega} &= \frac{1}{M}[P_m - P_e - D(\omega - 1)] \\ \dot{E}'_q &= \frac{1}{T_{d0}}(E_{fd} - E_q) \\ \dot{E}'_{fd} &= -\frac{1}{T_A}E'_{fd} + \frac{K_A}{T_A}(V_{ref} - V_t) \end{aligned} \quad (1)$$

Where

$$\begin{aligned} P_e &= V_{td}I_{td} + V_{tq}I_{tq} = E'_qI_{tq} + (x_q - x'_d)I_{td}I_{tq} \\ E_{fd} &= E_{fd0} + E'_{fd} \\ E_q &= E'_q + (x_d - x'_d)I_{td} \\ V_t &= \sqrt{V_{td}^2 + V_{tq}^2} = \sqrt{(x_qI_{tq})^2 + (E'_q - x'_dI_{td})^2} \end{aligned}$$

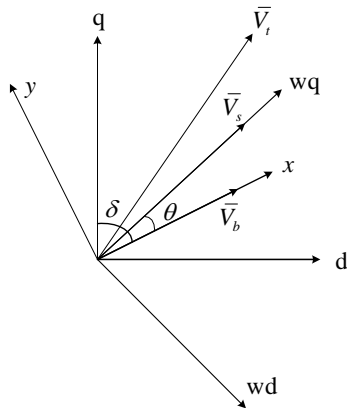

Figure 2: Phasor diagram of power system

$$\begin{aligned} \bar{V}_t &= \bar{V}_w + jX_t\bar{I}_t \\ \bar{V}_w &= \bar{V}_s - jX_w\bar{I}_w \\ \bar{V}_b &= \bar{V}_w - jX_b(\bar{I}_t + \bar{I}_w) \end{aligned} \quad (2)$$

From Eq.(2) and Fig.2, it can have:

$$\begin{aligned} \begin{bmatrix} I_{tq} \\ I_{wq} \end{bmatrix} &= \begin{bmatrix} c_{11} & c_{12} \\ c_{21} & c_{22} \end{bmatrix} \begin{bmatrix} V_b \sin \delta \\ V_s \sin(\delta - \theta) \end{bmatrix} \\ \begin{bmatrix} I_{td} \\ I_{wd} \end{bmatrix} &= \begin{bmatrix} d_{11} & d_{12} \\ d_{21} & d_{22} \end{bmatrix} \begin{bmatrix} V_s \cos(\delta - \theta) - V_b \cos \delta \\ E'_q - V_b \cos \delta \end{bmatrix} \end{aligned} \quad (3)$$

Where

$$\begin{aligned} \begin{bmatrix} c_{11} & c_{12} \\ c_{21} & c_{22} \end{bmatrix} &= \begin{bmatrix} X_q + X_t + X_b & X_b \\ X_q + X_t & -X_w \end{bmatrix}^{-1}, \\ \begin{bmatrix} d_{11} & d_{12} \\ d_{21} & d_{22} \end{bmatrix} &= \begin{bmatrix} X_b & X_w + X_b \\ X'_d + X_t + X_b & X_b \end{bmatrix}^{-1} \end{aligned}$$

Fig.3 shows the configuration of rotor side converter control of DFIG-based wind turbine.

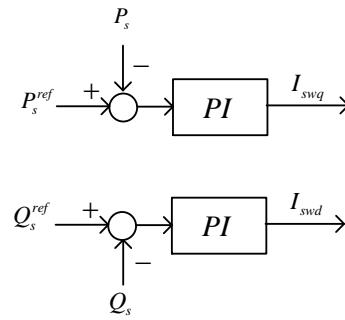

Figure 3: Rotor side converter control of DFIG-based wind turbine

From fig.3, it can have the three order simplified equations of DFIG-based wind turbine:

$$\begin{aligned} \frac{ds_w}{dt} &= \frac{1}{T_j}[P - P_{wm} - D_w(s_w - s_{w0})] \\ \frac{dX_p}{dt} &= K_{Pi}(P_s^{ref} - P_s) \\ \frac{dX_Q}{dt} &= K_{Qi}(Q_s^{ref} - Q_s) \end{aligned} \quad (4)$$

Where  $X_p$  and  $X_Q$  are two state variables of PI controllers.

The total output power of DFIG is:

$$\begin{aligned} P &= V_{sx}I_{wx} + V_{sy}I_{wy} = V_s \cos \theta \cdot I_{wx} + V_s \sin \theta \cdot I_{wy} \\ Q &= V_{sy}I_{wx} - V_{sx}I_{wy} = V_s \sin \theta \cdot I_{wx} - V_s \cos \theta \cdot I_{wy} \end{aligned} \quad (5)$$

The active and reactive power of rotor in DFIG are:

$$\begin{aligned} P_r &= V_{rwd}I_{rwd} + V_{rwd}I_{rwd} \\ Q_r &= V_{rwd}I_{rwd} - V_{rwd}I_{rwd} \end{aligned} \quad (6)$$

The active and reactive power of stator in DFIG are:

$$\begin{aligned} P_s &= V_{swd}I_{swd} + V_{swq}I_{swq} \\ Q_s &= V_{swq}I_{swd} - V_{swd}I_{swq} \end{aligned} \quad (7)$$

The coordinate transformation equations are:

$$\begin{aligned} I_{wx} &= I_{wd} \sin \delta + I_{wq} \cos \delta \\ I_{wy} &= -I_{wd} \cos \delta + I_{wq} \sin \delta \end{aligned} \quad (8)$$

Linearization of Eq.(1) is:

$$\begin{aligned}
\dot{\Delta\delta} &= \omega_0 \Delta\omega \\
\dot{\Delta\omega} &= \frac{1}{M} (-\Delta P_e - D\Delta\omega) \\
\dot{\Delta E'_q} &= \frac{1}{T_{d0}} (\Delta E'_{fd} - \Delta E'_q) \\
\dot{\Delta E'_{fd}} &= -\frac{1}{T_A} \Delta E'_{fd} - \frac{K_A}{T_A} \Delta V_t
\end{aligned} \tag{9}$$

Where

$$\begin{aligned}
\Delta P_e &= I_{iq0} \Delta E'_q + (x_q - x_d) I_{iq0} \Delta I_{td} + [E_{q0} + (x_q - x_d) I_{td0}] \Delta I_{td} \\
\Delta E'_q &= \Delta E_q - (x_d - x_d') \Delta I_{td} \\
\Delta V_t &= \frac{x_q^2 I_{iq0} \Delta I_{td} + (E_{q0} - x_d' I_{td0}) (\Delta E_q - x_d' \Delta I_{td})}{\sqrt{(x_q I_{iq0})^2 + (E_{q0} - x_d' I_{td0})^2}}
\end{aligned}$$

The above equations are simplified as:

$$\begin{aligned}
\Delta P_e &= K_1 \Delta\delta + K_2 \Delta E'_q + k_{pp} \Delta P + k_{pQ} \Delta Q \\
\Delta E'_q &= K_3 \Delta E_q + K_4 \Delta\delta + k_{EP} \Delta P + k_{EQ} \Delta Q \\
\Delta V_t &= K_5 \Delta\delta + K_6 \Delta E_q + k_{VP} \Delta P + k_{VQ} \Delta Q
\end{aligned} \tag{10}$$

Thus, the linearized model of the synchronous generator is:

$$\begin{aligned}
\begin{bmatrix} \dot{\Delta\delta} \\ \dot{\Delta\omega} \\ \dot{\Delta E'_q} \\ \dot{\Delta E'_{fd}} \end{bmatrix} &= \begin{bmatrix} 0 & \omega_0 & 0 & 0 \\ -M^{-1}K_1 & -M^{-1}D & -M^{-1}K_2 & 0 \\ -T_{d0}^{-1}K_4 & 0 & -T_{d0}^{-1}K_3 & T_{d0}^{-1} \\ -T_A^{-1}K_5K_A & 0 & -T_A^{-1}K_6K_A & -T_A^{-1} \end{bmatrix} \begin{bmatrix} \Delta\delta \\ \Delta\omega \\ \Delta E'_q \\ \Delta E'_{fd} \end{bmatrix} \\
&+ \begin{bmatrix} 0 \\ -M^{-1}k_{pp} \\ -T_{d0}^{-1}k_{EP} \\ -T_A^{-1}K_A k_{VP} \end{bmatrix} \Delta P + \begin{bmatrix} 0 \\ -M^{-1}k_{pQ} \\ -T_{d0}^{-1}k_{EQ} \\ -T_A^{-1}K_A k_{VQ} \end{bmatrix} \Delta Q = \mathbf{A} \cdot \mathbf{AX} + \mathbf{B} \cdot \begin{bmatrix} \Delta P \\ \Delta Q \end{bmatrix}
\end{aligned} \tag{11}$$

By linearizing Eq.(6) and Eq.(7), it can have:

$$\Delta P_s = V_{s0} \Delta I_{swq} + I_{swq0} \Delta V_s \tag{12}$$

$$\begin{aligned}
\Delta Q_s &= V_{s0} \Delta I_{swd} + I_{swd0} \Delta V_s \\
\Delta P_r &= I_{rwd0} \Delta V_{rwd} + I_{rvq0} \Delta V_{rvq} + V_{rwd0} \Delta I_{rwd} + V_{rvq0} \Delta I_{rvq} \\
\Delta Q_r &= -I_{rvq0} \Delta V_{rwd} + I_{rwd0} \Delta V_{rvq} + V_{rvq0} \Delta I_{rwd} - V_{rwd0} \Delta I_{rvq}
\end{aligned} \tag{13}$$

Where

$$\begin{aligned}
\Delta I_{rwd} &= -\frac{1}{X_m} \Delta V_s - \frac{X_{ss}}{X_m} \Delta I_{swd}, \Delta I_{rvq} = -\frac{X_{ss}}{X_m} \Delta I_{swq}, \\
\Delta V_{rwd} &= (X_{rr} - \frac{X_m^2}{X_{ss}}) I_{rvq0} \Delta s_w - R_r \Delta I_{rwd} + s_{w0} (X_{rr} - \frac{X_m^2}{X_{ss}}) \Delta I_{rvq}, \\
\Delta V_{rvq} &= [(\frac{X_m^2}{X_{ss}} - X_{rr}) I_{rwd0} + \frac{X_m}{X_{rr}} V_{s0}] \Delta s_w + s_{w0} (\frac{X_m^2}{X_{ss}} - X_{rr}) \Delta I_{rwd} \\
&\quad - R_r \Delta I_{rvq} + s_{w0} \frac{X_m}{X_{rr}} \Delta V_s
\end{aligned}$$

$$\Delta I_{swq} = -K_P(s) \Delta P_s, \Delta I_{swd} = -K_Q(s) \Delta Q_s$$

And Eq.(12) and Eq.(13) can be rewritten as:

$$\Delta P_s = \frac{I_{swq0}}{1 + V_{s0} K_P(s)} \Delta V_s, \Delta Q_s = \frac{I_{swd0}}{1 + V_{s0} K_Q(s)} \Delta V_s \tag{14}$$

$$\begin{aligned}
\Delta P_r &= K_{Pr-s} \Delta s_w + K_{Pr-ld} \Delta I_{rwd} + K_{Pr-lq} \Delta I_{rvq} + K_{Pr-Vs} \Delta V_s \\
\Delta Q_r &= K_{Qr-s} \Delta s_w + K_{Qr-ld} \Delta I_{rwd} + K_{Qr-lq} \Delta I_{rvq} + K_{Qr-Vs} \Delta V_s
\end{aligned} \tag{15}$$

Where

$$\begin{aligned}
K_{Pr-s} &= \frac{X_m}{X_{rr}} I_{rvq0} V_{s0}, K_{Pr-ld} = V_{rwd0} - I_{rwd0} R_r + I_{rvq0} s_{w0} (\frac{X_m^2}{X_{ss}} - X_{rr}) \\
K_{Pr-lq} &= V_{rvq0} - I_{rvq0} R_r - I_{rwd0} s_{w0} (\frac{X_m^2}{X_{ss}} - X_{rr}), K_{Pr-Vs} = \frac{X_m}{X_{rr}} I_{rvq0} s_{w0} \\
K_{Qr-s} &= (\frac{X_m^2}{X_{ss}} - X_{rr}) (I_{rwd0}^2 + I_{rvq0}^2) + \frac{X_m}{X_{rr}} I_{rwd0} V_{s0}, \\
K_{Qr-ld} &= V_{rvq0} + I_{rvq0} R_r + I_{rwd0} s_{w0} (\frac{X_m^2}{X_{ss}} - X_{rr}), \\
K_{Qr-lq} &= -V_{rwd0} - I_{rwd0} R_r + I_{rvq0} s_{w0} (\frac{X_m^2}{X_{ss}} - X_{rr}), K_{Qr-Vs} = \frac{X_m}{X_{rr}} I_{rwd0} s_{w0}
\end{aligned}$$

The above equations are simplified as:

$$\begin{aligned}
\Delta P_r &= K_{Pr-s} \Delta s_w + K_{Pr-Vs}(s) \Delta V_s \\
\Delta Q_r &= K_{Qr-s} \Delta s_w + K_{Qr-Vs}(s) \Delta V_s
\end{aligned} \tag{16}$$

Where

$$\begin{aligned}
K_{Pr-Vs}(s) &= K_{Pr-Vs} - \frac{K_{Pr-ld}}{X_m} + \frac{X_{ss}}{X_m} K_{Pr-ld} K_Q(s) \frac{I_{swd0}}{1 + V_{s0} K_Q(s)} \\
&\quad + \frac{X_{ss}}{X_m} K_{Pr-lq} K_P(s) \frac{I_{swq0}}{1 + V_{s0} K_P(s)} \\
K_{Qr-Vs}(s) &= K_{Qr-Vs} - \frac{K_{Qr-ld}}{X_m} + \frac{X_{ss}}{X_m} K_{Qr-ld} K_Q(s) \frac{I_{swd0}}{1 + V_{s0} K_Q(s)} \\
&\quad + \frac{X_{ss}}{X_m} K_{Qr-lq} K_P(s) \frac{I_{swq0}}{1 + V_{s0} K_P(s)}
\end{aligned}$$

Linearization of total output power in DFIG:

$$\Delta P = K_{Pr-s} \Delta s_w + [\frac{I_{swq0}}{1 + V_{s0} K_P(s)} + K_{Pr-Vs}(s)] \Delta V_s \tag{17}$$

$$\Delta Q = K_{Qr-s} \Delta s_w + [\frac{I_{swd0}}{1 + V_{s0} K_Q(s)} + K_{Qr-Vs}(s)] \Delta V_s$$

By linearizing the first equation of Eq.(4), it can have:

$$\Delta \dot{s}_w = \frac{1}{T_j} (\Delta P_{we} - D_w \Delta s_w) \tag{18}$$

From Eq.(17) and Eq.(18), it can have:

$$\Delta \dot{s}_w = A_w \Delta s_w + B_w(s) \Delta V_s \tag{19}$$

Where

$$\begin{aligned}
A_w &= \frac{1}{T_j} [\frac{K_{Pr-s}}{1 - s_{w0}} + \frac{P_{we0}}{(1 - s_{w0})^2} - D_w] \\
B_w &= \frac{1}{T_j (1 - s_{w0})} [\frac{I_{swq0}}{1 + V_{s0} K_P(s)} + K_{Pr-Vs}(s)]
\end{aligned}$$

By substituting Eq.(19) into Eq.(17), it can have:

$$\begin{aligned}
\Delta P &= G_P(s) \Delta V_s \\
\Delta Q &= G_Q(s) \Delta V_s
\end{aligned} \tag{20}$$

Where

$$\begin{aligned}
G_P(s) &= K_{Pr-s} (s - A_w)^{-1} B_w(s) + \frac{I_{swq0}}{1 + V_{s0} K_P(s)} + K_{Pr-Vs} \\
G_Q(s) &= K_{Qr-s} (s - A_w)^{-1} B_w(s) + \frac{I_{swd0}}{1 + V_{s0} K_Q(s)} + K_{Qr-Vs}
\end{aligned}$$

From Eq.(11) and Eq.(20), the simplified linearization model of the power system with DFIG-based wind turbine connected is:

$$\begin{aligned} \Delta \dot{\mathbf{X}} &= \mathbf{A} \cdot \Delta \mathbf{X} + \mathbf{B} \cdot \begin{bmatrix} \Delta P \\ \Delta Q \end{bmatrix}, \Delta V_s = \mathbf{C} \cdot \Delta \mathbf{X} + \mathbf{D} \cdot \begin{bmatrix} \Delta P \\ \Delta Q \end{bmatrix} \\ \Delta P &= G_p(s) \Delta V_s, \Delta Q = G_Q(s) \Delta V_s \end{aligned} \quad (21)$$

## 2.2 The impact of virtual inertia control for SMIB power system with grid-connected DFIG-based wind turbines

The principle of classical virtual inertia control is:

$$P_s^{ref} = P_{s0}^{ref} - K_{df} \frac{df}{dt} - K_{pf} (f - 1) \quad (22)$$

In the SMIB power system, the power system frequency  $f$  is substituted by the rotor speed of synchronous generator  $\omega$ .

Linearization of Eq.(22) is:

$$\Delta P_s^{ref} = -(sK_{df} + K_{pf}) \Delta \omega \quad (23)$$

The reference value of stator active power  $P_s^{ref}$  is not a constant in Fig.1. Eq.(14) and Eq.(15) will be rewritten as:

$$\Delta P_s = \frac{I_{swq0}}{1 + V_{s0} K_P(s)} \Delta V_s + \frac{V_{s0} K_P(s)}{1 + V_{s0} K_P(s)} \Delta P_s^{ref} \quad (24)$$

$$\Delta Q_s = \frac{I_{swd0}}{1 + V_{s0} K_Q(s)} \Delta V_s$$

$$\Delta P_r = K_{Pr-s} \Delta s_w + K_{Pr-Vs} (s) \Delta V_s + K_{Pr-P} (s) \Delta P_s^{ref} \quad (25)$$

$$\Delta Q_r = K_{Qr-s} \Delta s_w + K_{Qr-Vs} (s) \Delta V_s + K_{Qr-P} (s) \Delta P_s^{ref}$$

Where

$$K_{Pr-P} (s) = -\frac{X_{ss} K_P(s) K_{Pr-Iq}}{X_m [1 + V_{s0} K_P(s)]}, K_{Qr-P} (s) = -\frac{X_{ss} K_P(s) K_{Qr-Iq}}{X_m [1 + V_{s0} K_P(s)]}$$

From Eq.(17), it can have the linearization of DFIG total output power is:

$$\begin{aligned} \Delta P &= K_{Pr-s} \Delta s_w + \left[ \frac{I_{swq0}}{1 + V_{s0} K_P(s)} + K_{Pr-Vs} (s) \right] \Delta V_s \\ &+ \left[ \frac{V_{s0} K_P(s)}{1 + V_{s0} K_P(s)} + K_{Pr-P} (s) \right] \Delta P_s^{ref} \end{aligned} \quad (26)$$

$$\Delta Q = K_{Qr-s} \Delta s_w + \left[ \frac{I_{swd0}}{1 + V_{s0} K_Q(s)} + K_{Qr-Vs} (s) \right] \Delta V_s + K_{Qr-P} \Delta P_s^{ref}$$

From Eq.(19) and Eq.(26), it can have:

$$\Delta \dot{s}_w = A_w \Delta s_w + B_w (s) \Delta V_s + C_w (s) \Delta P_s^{ref} \quad (27)$$

Where

$$C_w (s) = \frac{1}{T_j (1 - s_{w0})} \left[ \frac{V_{s0} K_P(s)}{1 + V_{s0} K_P(s)} + K_{Pr-P} (s) \right]$$

By substituting Eq.(27) into Eq.(26), it can have:

$$\begin{aligned} \Delta P &= G_p(s) \Delta V_s + G_p'(s) \Delta P_s^{ref} \\ \Delta Q &= G_Q(s) \Delta V_s + G_Q'(s) \Delta P_s^{ref} \end{aligned} \quad (28)$$

Where

$$G_p'(s) = K_{Pr-s} (s - A_w)^{-1} C_w (s) + \frac{V_{s0} K_P(s)}{1 + V_{s0} K_P(s)} + K_{Pr-P}$$

$$G_Q'(s) = K_{Qr-s} (s - A_w)^{-1} C_w (s) + K_{Qr-P}$$

Thus, the linearization model of SMIB power system with DFIG-based wind turbine incorporated with virtual inertial control is:

$$\begin{aligned} \Delta \dot{\mathbf{X}} &= \mathbf{A} \cdot \Delta \mathbf{X} + \mathbf{B} \cdot \begin{bmatrix} \Delta P \\ \Delta Q \end{bmatrix}, \Delta V_s = \mathbf{C} \cdot \Delta \mathbf{X} + \mathbf{D} \cdot \begin{bmatrix} \Delta P \\ \Delta Q \end{bmatrix} \\ \Delta P &= G_p(s) \Delta V_s + G_p'(s) \Delta P_s^{ref}, \Delta Q = G_Q(s) \Delta V_s + G_Q'(s) \Delta P_s^{ref} \end{aligned} \quad (29)$$

## 2.3 Damping torque analysis with taking virtual inertia control for DFIG-based wind turbine into consideration

From Eq.(29), the Phillips-Heffron model of the SMIB power system with DFIG-based wind turbine connected incorporated with virtual inertial control is given in Fig.4.

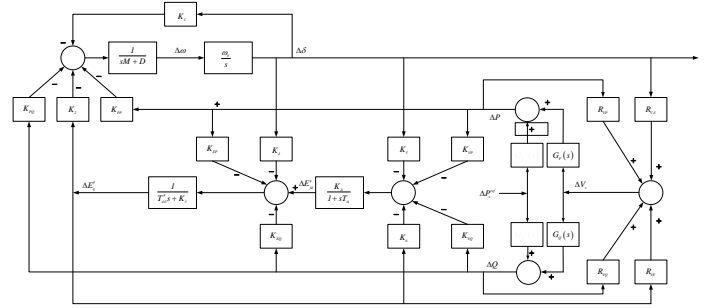

Figure 4: Phillips-Heffron model of SMIB power system with virtual inertial control for DFIG-based wind turbine

From Fig.4, it can have:

$$\begin{aligned} \begin{bmatrix} \Delta \dot{E}_q' \\ \Delta \dot{E}_{fd}' \end{bmatrix} &= \begin{bmatrix} -\frac{K_4}{T_{d0}'} \\ -\frac{K_A K_5}{T_A} \end{bmatrix} \Delta \delta + \begin{bmatrix} -\frac{K_3}{T_{d0}'} & \frac{1}{T_{d0}'} \\ -\frac{K_A K_6}{T_A} & -\frac{1}{T_A} \end{bmatrix} \begin{bmatrix} \Delta E_q' \\ \Delta E_{fd}' \end{bmatrix} \\ &+ \begin{bmatrix} -\frac{K_{EP}}{T_{d0}'} & -\frac{K_{EQ}}{T_{d0}'} \\ -\frac{K_A K_{VP}}{T_A} & -\frac{K_A K_{VQ}}{T_A} \end{bmatrix} \begin{bmatrix} \Delta P \\ \Delta Q \end{bmatrix} \\ &= \mathbf{E}_2 \Delta \delta + \mathbf{A}_2 \begin{bmatrix} \Delta E_q' \\ \Delta E_{fd}' \end{bmatrix} + \mathbf{B}_2 \begin{bmatrix} \Delta P \\ \Delta Q \end{bmatrix} \\ \Delta T &= \begin{bmatrix} K_2 & 0 \end{bmatrix} \begin{bmatrix} \Delta E_q' \\ \Delta E_{fd}' \end{bmatrix} + \begin{bmatrix} K_{PP} & K_{PQ} \end{bmatrix} \begin{bmatrix} \Delta P \\ \Delta Q \end{bmatrix} \\ &= \mathbf{C}_2 \begin{bmatrix} \Delta E_q' \\ \Delta E_{fd}' \end{bmatrix} + \mathbf{D}_2 \begin{bmatrix} \Delta P \\ \Delta Q \end{bmatrix} \end{aligned} \quad (30)$$

From Eq.(28), it can have:

$$\begin{aligned} \begin{bmatrix} \Delta P \\ \Delta Q \end{bmatrix} &= \begin{bmatrix} G_p(s) \\ G_Q(s) \end{bmatrix} \Delta V_s + \begin{bmatrix} G_p'(s) \\ G_Q'(s) \end{bmatrix} \Delta P_s^{ref} \\ &= \mathbf{G}(s) \cdot \Delta V_s + \mathbf{G}'(s) \cdot \Delta P_s^{ref} \end{aligned} \quad (31)$$

From Eq.(30) and Eq.(31), the electric torque contributed from virtual inertial control loop of DFIG-based wind turbine to electromechanical oscillation loop of synchronous generator is:

$$\begin{aligned} \Delta T &= \mathbf{C}_2(s\mathbf{I} - \mathbf{A}_2)^{-1}\mathbf{E}_2\Delta\delta + [\mathbf{C}_2(s\mathbf{I} - \mathbf{A}_2)^{-1}\mathbf{B}_2 + \mathbf{D}_2] \begin{bmatrix} \Delta P \\ \Delta Q \end{bmatrix} \\ &= \mathbf{C}_2(s\mathbf{I} - \mathbf{A}_2)^{-1}\mathbf{E}_2\Delta\delta + [\mathbf{C}_2(s\mathbf{I} - \mathbf{A}_2)^{-1}\mathbf{B}_2 + \mathbf{D}_2]\mathbf{G}(s) \cdot \Delta V_s \\ &\quad + [\mathbf{C}_2(s\mathbf{I} - \mathbf{A}_2)^{-1}\mathbf{B}_2 + \mathbf{D}_2]\mathbf{G}'(s) \cdot \Delta P_s^{ref} \end{aligned} \quad (32)$$

From Eq.(10), it can have:

$$\Delta E_q' = G_1(s)\Delta\delta + G_2(s)\Delta P + G_3(s)\Delta Q \quad (33)$$

Where

$$G_1(s) = -\frac{K_A K_5 + K_4(sT_A + 1)}{(sT_{d0}' + K_3)(sT_A + 1) + K_A K_6}$$

$$G_2(s) = -\frac{K_A K_{VP} + K_{EP}(sT_A + 1)}{(sT_{d0}' + K_3)(sT_A + 1) + K_A K_6}$$

$$G_3(s) = -\frac{K_A K_{VQ} + K_{EQ}(sT_A + 1)}{(sT_{d0}' + K_3)(sT_A + 1) + K_A K_6}$$

From Eq.(31) and Eq.(33), it can have:

$$\begin{aligned} \Delta V_s &= \frac{R_{V\delta} + R_{VE}G_1(s)}{1 - [R_{VE}G_2(s) + R_{VP}]G_P(s) - [R_{VE}G_3(s) + R_{VQ}]G_Q(s)} \Delta\delta \\ &\quad + \frac{[R_{VP} + R_{VE}G_2(s)]G_P'(s) + [R_{VQ} + R_{VE}G_3(s)]G_Q'(s)}{1 - [R_{VE}G_2(s) + R_{VP}]G_P(s) - [R_{VE}G_3(s) + R_{VQ}]G_Q(s)} \Delta P_s^{ref} \end{aligned} \quad (34)$$

By substituting Eq.(34) into Eq.(32), it can have:

$$\begin{aligned} \Delta T &= \left\{ \mathbf{C}_2(s\mathbf{I} - \mathbf{A}_2)^{-1}\mathbf{E}_2 + \frac{[\mathbf{C}_2(s\mathbf{I} - \mathbf{A}_2)^{-1}\mathbf{B}_2 + \mathbf{D}_2]\mathbf{G}(s)[R_{V\delta} + R_{VE}G_1(s)]}{1 - [R_{VE}G_2(s) + R_{VP}]G_P(s) - [R_{VE}G_3(s) + R_{VQ}]G_Q(s)} \right\} \Delta\delta \\ &\quad + \left\{ [\mathbf{C}_2(s\mathbf{I} - \mathbf{A}_2)^{-1}\mathbf{B}_2 + \mathbf{D}_2]\mathbf{G}'(s) + \frac{[\mathbf{C}_2(s\mathbf{I} - \mathbf{A}_2)^{-1}\mathbf{B}_2 + \mathbf{D}_2]\mathbf{G}(s) \cdot [R_{VP} + R_{VE}G_2(s)]G_P'(s) + [R_{VQ} + R_{VE}G_3(s)]G_Q'(s)}{1 - [R_{VE}G_2(s) + R_{VP}]G_P(s) - [R_{VE}G_3(s) + R_{VQ}]G_Q(s)} \right\} \Delta P_s^{ref} \\ &= F(s)\Delta\delta + F'(s)\Delta P_s^{ref} \end{aligned} \quad (35)$$

Thus,  $F'(s)\Delta P_s^{ref}$  is the damping torque contributed from virtual inertial control loop of DFIG-based wind turbine to the electromechanical oscillation loop of the synchronous generator. From Eq.(23) and Eq.(35), it can have the electric torque of virtual inertial loop in DFIG:

$$\Delta T_{vic} = -(sK_{df} + K_{pf})F'(s)\Delta\omega \quad (36)$$

When the oscillation angular frequency is  $\omega_s$ , the total damping torque of electromechanical oscillation loop is:

$$D_{vic} = -\text{Re}[(K_{pf} + j\omega_s K_{df})F'(j\omega_s)] \quad (37)$$

### 3 Case Study

The output active power of synchronous generator is  $P_e = 0.6$ , and the reference voltage amplitude of synchronous generator terminal is  $V_{tref} = 1.05$ ; The output active power of DFIG

$P_{we} = 0.4$ , and the power factor  $\cos\varphi = 0.95$ .

The voltages of bus are:

$$\bar{V}_t = 1.05 \angle 13.20^\circ, \bar{V}_s = 1.04 \angle 11.63^\circ, \bar{V}_w = 1.03 \angle 8.41^\circ, \bar{V}_b = 1.0$$

The line currents are:  $\bar{I}_t = 0.60 \angle -4.87^\circ$ ,  $\bar{I}_w = 0.40 \angle -6.57^\circ$ ,

$$\bar{I}_b = 1.00 \angle 5.55^\circ. \text{ The active power of synchronous generator and DFIG is } 0.6 \text{ and } 0.4, \text{ respectively.}$$

From Eq.(29), it can have:

$$\mathbf{A} = \begin{bmatrix} 0 & 314.1593 & 0 & 0 \\ -0.2157 & -0.3750 & -0.1354 & 0 \\ -0.1625 & 0 & -0.6350 & 0.2 \\ -52.9753 & 0 & -839.9212 & -100 \end{bmatrix},$$

$$\mathbf{B} = \begin{bmatrix} 0 & 0 \\ 0.0320 & -0.0003 \\ 0.0086 & 0.0578 \\ 14.2114 & -23.9430 \end{bmatrix}, \quad \mathbf{C} = [-0.0027 \ 0 \ 0.4017 \ 0],$$

$$\mathbf{D} = [-0.0296 \ 0.2243].$$

$$G_P = 0.2519 + j0.0125, \quad G_Q = 0.0828 + j0.0035,$$

$$G_P' = 0.3049 - j0.0219, \quad G_Q' = 0.0000 + j0.0000.$$

From Eq.(35), it can have the electric torque:

$$\Delta T = (-0.0070 + j0.0333)\Delta\delta + (-0.0771 + j0.0042)\Delta P_s^{ref}$$

The damping torque contributed from the virtual inertial control loop of DFIG-based wind turbine to synchronous generator electromechanical oscillation loop is:

$$(-0.0771 + j0.0042)\Delta P_s^{ref}.$$

If  $K_{df} = 10, K_{pf} = 10$ , from Eq.(23), the relationship between

$$\Delta P_s^{ref} \text{ and } \Delta\omega \text{ is: } \Delta P_s^{ref} = -(7.3296 + j82.1398)\Delta\omega.$$

Where  $s$  is the eigenvalue of matrix  $\mathbf{A}$  of DFIG (without the virtual inertial control):  $\lambda_0 = -0.2670 + j8.2140$ .

From Eq.(36), it can have the electric torque of the virtual inertial control loop in DFIG:  $\Delta T_{vic} = (0.9086 + j6.3003)\Delta\omega$ .

From Eq.(37), it can have the total damping torque of electromechanical oscillation loop:  $D_{vic} = 0.7038$ .

Thus the oscillation mode (without the virtual inertial control) of power system is:  $\lambda_0 = -0.2670 + j8.2140$ , and the oscillation mode (with the virtual inertial control) of power system is:  $\lambda_1 = -0.3140 + j7.8439$ .

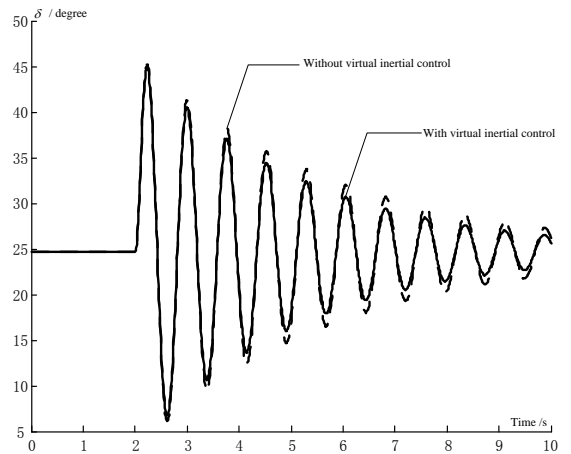

Figure 5: Simulation results of power system with/without virtual inertial control

If  $K_{df} = 0$ ,  $K_{pf}$  is changed from 1 to 10 with a step of 1.0, the oscillation modes and the damping torque analysis results are shown in Table.1.

$K_{pf}$	Oscillation mode	Damping torque
1	-0.2719 + j8.2142	0.0772
2	-0.2767 + j8.2144	0.1544
3	-0.2816 + j8.2146	0.2316
4	-0.2864 + j8.2147	0.3088
5	-0.2913 + j8.2149	0.3861
6	-0.2961 + j8.2151	0.4633
7	-0.3010 + j8.2153	0.5405
8	-0.3058 + j8.2154	0.6177
9	-0.3106 + j8.2156	0.6949
10	-0.3155 + j8.2158	0.7721

Table 1: The oscillation modes and damping torques in power system with different parameter  $K_{pf}$ .

If  $K_{pf} = 0$ ,  $K_{df}$  is changed from 1 to 10, the oscillation modes and the damping torque analysis results are shown in Table.2.

$K_{df}$	Oscillation mode	Damping torque
1	-0.2673 + j8.1744	0.0068
2	-0.2676 + j8.1354	0.0137
3	-0.2679 + j8.0970	0.0205
4	-0.2682 + j8.0591	0.0273
5	-0.2685 + j8.0217	0.0342
6	-0.2688 + j7.9848	0.0410
7	-0.2690 + j7.9484	0.0478
8	-0.2693 + j7.9125	0.0547
9	-0.2695 + j7.8771	0.0615
10	-0.2698 + j7.8422	0.0683

Table 2: The oscillation modes and damping torque in power system with different parameter  $K_{df}$ .

From Table.1 and Table.2, it can be seen that the DFIG-based wind turbine with virtual inertial control can provide positive damping torque in the SMIB power system.

## 4 Conclusion

The classical virtual inertial control strategy of DFIG based wind turbines called supplementary control loop for inertial response is investigated in this paper. The proposed method can supply controllable virtual inertia from DFIGs to the power system so that the system frequency stability can be strengthened through inertial control of wind turbines on the basis of damping torque analysis. Simulation results show that the DFIG-based wind turbine with virtual inertial control

can provide positive damping torque to the power system so that it may enhance the system steady-state behaviour indirectly. Thus, the DFIG-based wind turbines are able to support primary frequency control and to emulate inertia by applying additional supplementary control loop.

## Acknowledgements

The author would like to acknowledge the financial support of the Science Bridge Project funded by the UKRC and the Queen's University of Belfast, UK, the National Basic Research Program of China (973Program)(2012CB215204), and the NSFC project (51407068), China.

## References

- [1] Ping-Kwan. Keung, P. Li, H. Banakar and B. T. Ooi. "Kinetic energy of wind-turbine generators for system frequency support", *The Journal, IEEE Trans Power Syst.*, **24**, 1. 279-287. (2009).
- [2] J. Morren, J. Pierik and S. W. de Haan. "Inertial response of variable". *The Journal, Elect. Power Syst. Res.*, **76**, 980-987. (2006).
- [3] K. Mustafa and J. V. Milanovic. "Dynamic contribution of DFIG-based wind plants to system frequency disturbances", *The Journal, IEEE Trans Power Syst.*, **24**, 2. 859-867. (2009).
- [4] Ekanayake, Janaka, and N. Jenkins. "Comparison of the response of doubly fed and fixed-speed induction generator wind turbines to changes in network frequency", *The Journal, Energy conversion IEEE Trans.*, **19**, 4. 800-802. (2004).
- [5] Lator, A. Mullane and M. O'Malley. "Frequency Control and Wind turbine Technologies", *The Journal, IEEE Trans. Power Syst.*, **20**, 4. (2005).
- [6] J. Morren, W. H. de Haan, Wil L. Kling and J. A. Ferreira. "Wind turbines emulating inertia and supporting primary frequency control", *The Journal, IEEE Trans Power Syst.*, **21**, 1. 433-434. (2006).

## Appendix

Parameters of example single-machine infinite-bus power system (in per unit except indicated):

Generator:  $X_d = 0.8$ ,  $X_q = 0.4$ ,  $X_d' = 0.05$ ,  $M = 8$ ,  $D = 20$ ,  $T_{d0} = 5s$ ,

Transmission line:  $X_{l1} = 0.15$ ,  $X_{l2} = 0.15$ ,  $X_l = 0.15$ ,

AVR:  $T_A = 0.01s$ ,  $K_A = 10$

DFIG wind turbine:  $T_j = 8$ ,  $D = 0$ ,  $S_w = 0.1$ ,

$R_r = 0.0415$ ,  $R_s = 0$ ,  $X_r = 0.1225$ ,  $X_s = 0.1784$ ,  $X_m = 2.4012$ .