

Analysis and modeling of buck converter in discontinuous-output-inductor-current mode operation

YANG, Jianbo, ZHANG, Weiping, AL-NAEMI, Faris and CHEN, Xiaoping

Available from Sheffield Hallam University Research Archive (SHURA) at:

<http://shura.shu.ac.uk/14287/>

This document is the author deposited version. You are advised to consult the publisher's version if you wish to cite from it.

Published version

YANG, Jianbo, ZHANG, Weiping, AL-NAEMI, Faris and CHEN, Xiaoping (2013). Analysis and modeling of buck converter in discontinuous-output-inductor-current mode operation. *Energy and Power Engineering*, 5 (4B), 850-856.

Repository use policy

Copyright © and Moral Rights for the papers on this site are retained by the individual authors and/or other copyright owners. Users may download and/or print one copy of any article(s) in SHURA to facilitate their private study or for non-commercial research. You may not engage in further distribution of the material or use it for any profit-making activities or any commercial gain.

Analysis and Modeling of Buck Converter in Discontinuous-Output-Inductor-Current Mode Operation*

Jianbo Yang¹, Weiping Zhang², Faris Al-Naemi¹, Xiaoping Chen²,

¹Materials and Engineering Research Institute (MERI), Sheffield Hallam University (SHU), Sheffield, UK

²Lab of Green Power & Energy System (GPES), North China University of Technology (NCUT), Beijing, China
Email: jumbo-yang@hotmail.com

Received September, 2012

ABSTRACT

The Buck converter with LC input filter operating in discontinuous output current mode has a high power factor with a constant duty cycle. A Buck converter in this operation mode can reduce the reverse recovery loss of the freewheeling diode thus increase the efficiency. The operation, power factor analysis and modeling of the converter are studied in this paper. Experimental results are presented to verify the theoretical predictions.

Keywords: Buck Converter; Power Factor Correction; Modeling

1. Introduction

AC/DC converter has been studied as a high-power-factor rectifier. The most popular power stage circuit of the AC/DC converter is a Boost converter [1,2]. The Boost converter has an input inductor which naturally makes the input current continuous and less of harmonics. However, the disadvantage is the output has to be higher than the peak input voltage. Unlike the Boost AC/DC converters, the Buck AC/DC converters have step-down characteristics as the output voltage is lower than the peak input voltage. The buck converter with LC input filter operating in discontinuous output inductor current mode has resistive and constant input impedance with a constant duty cycle D and a constant switching cycle T_s . Thus, the average input current of the converter follows the input voltage with a constant duty ratio control.

The low-frequency behavior modeling of the Buck converter with LC input filter operating in discontinuous output inductor mode is presented in this paper. Based on the model, the characteristic of the converter and the conditions for power factor correction is studied. The experimental verification is also given.

2. Power Stage

2.1. Circuit Configuration

The buck converter with LC input filter is shown in Fig-

ure 1. The discontinuous output inductor current mode means the current through the inductor L_2 is zero during part of one switching cycle. The converter can still operate in discontinuous capacitor voltage mode which means the voltage across C_1 is zero during part of a switching cycle. These two operation modes can be considered as dual of each other [3]. However, the voltage stress of the switch and diode will be very high when the converter operates in discontinuous capacitor voltage mode [4].

2.2. Operation Principles

The operation principles of the converter and the characteristic waveforms are presented in Figure 2.

There are three phases for the Buck converter with LC input filter operating in discontinuous inductor current mode.

Phase 1: $0 \sim DT_s$. switch S is turned on. D is reverse-biased. When the operation is in steady state, the average voltage across L_1 , over one switching cycle, is zero. The average voltage across C_1 over one switching cycle is

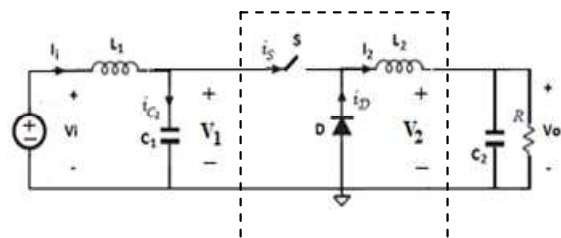

Figure 1. Buck AC/DC converter with LC input filter.

*Project supported by Natural Science foundation of China (No. 51277004). The Importation and Development of High-Caliber Talents Project of Beijing Municipal Institutions (No.IDHT20130501)

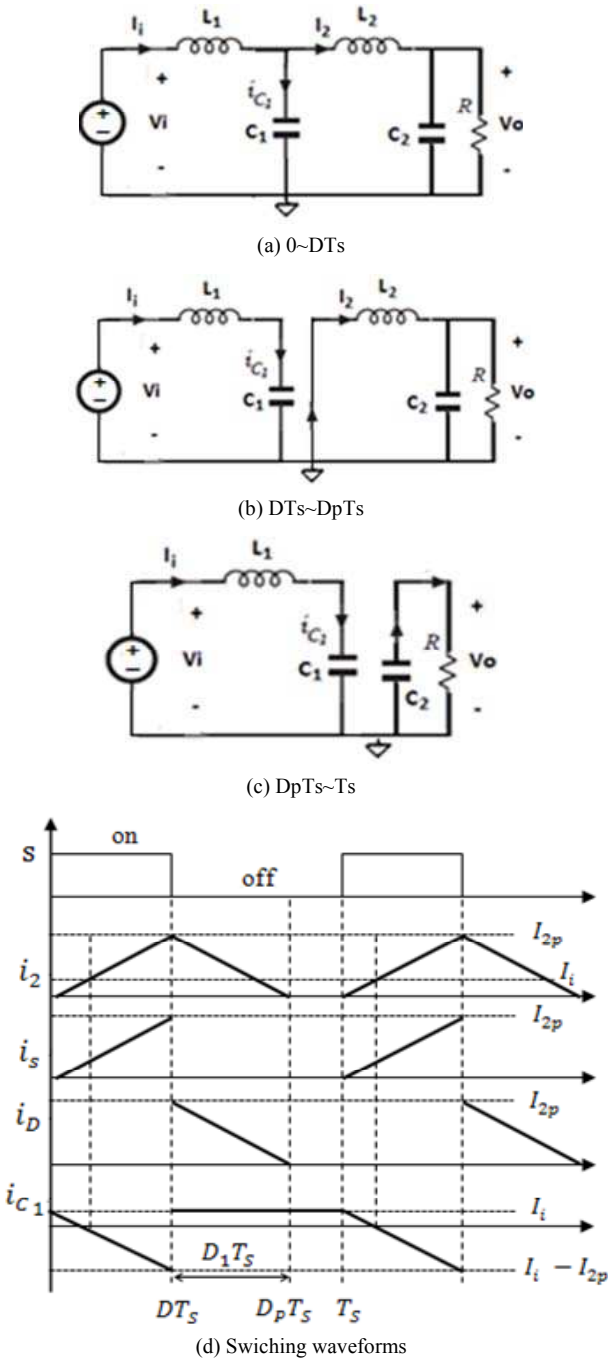

Figure 2. Discontinuous inductor current operation and waveforms.

equal to the input voltage. C_1 operates in continuous mode that Δu_{c1} is small during one switching cycle. Thus, the average voltage across C_1 over one switching cycle can be considered as the instantaneous voltage across C_1 . Therefore, L_2 is charging under constant voltage $(V_i - V_o)$. The peak current through L_2 is:

$$I_{2p} = \frac{(V_i - V_o)}{L_2} DT_s \quad (1)$$

The current through C_1 is $I_i - I_2$. When $I_2 < I_i$, i_{c1} is positive, C_1 is charging. When $I_2 > I_i$, C_1 is discharging.

Phase 2: $DT_s \sim DpTs$. S is closed D is forward-biased. L_2 is discharging and the current through L_2 falls to zero at $DpTs$. C_1 is charging. The peak current through L_2 can also be obtained as:

$$I_{2p} = \frac{V_o}{L_2} (D_p - D) T_s \quad (2)$$

Phase 3: $DpTs \sim Ts$; the switch S is still turned off. Current through L_2 falls to zero. Output is supported by C_2 individually. Combination of (1) and (2), the following equation can be obtained.

$$\frac{V_o}{V_i} = \frac{D}{D_p} > D \quad (3)$$

If the switching period T_s is much smaller than the input cycle T_i , the input voltage can be considered constant over one switching cycle [3]. Then, the input voltage V_i in (1), (3) can be directly replaced by $V_i \sin \omega_i t$ during half of line cycle T_i .

$$I_{2p} = \frac{(V_i \sin \omega_i t - V_o)}{L_2} DT_s \quad (4)$$

$$\frac{V_o}{V_i \sin \omega_i t} = \frac{D}{D_p} > D \quad (5)$$

V_o/V_i can be defined as η . then from equation (5), the relation between η and D is

$$\frac{\eta}{D} > \sin \omega_i t \quad (6)$$

Therefore, the converter will operate in discontinuous inductor current mode throughout half line cycle T_i when $\eta/D > 1$.

3. Power Analysis

As shown in Figure 2, the input current I_i is the sum of the switch current i_s and current through C_1 i_{c1} . The average current through C_1 is zero during one switching cycle in the steady state. Thus, the average input current equals to the average switching current over one switching cycle. According to (2) and (4), the average input current, over one switching cycle, can be obtained as,

$$I_{iavg} = \frac{(V \sin \omega_i t - V_o)}{2L_2} D^2 T_s \quad (7)$$

where I_{iavg} means the average input current over one switching cycle. As the switching cycle T_s is much smaller than the input cycle T_i , the input current can be considered constant over one switching cycle. Buck

converter operates only when the input voltage is higher than the output voltage. Therefore, (7) is valid only when $V \sin w_i t > V_o$. When the input rectified voltage equals to the output voltage,

$$t_1 = \frac{1}{w_i} \arcsin \frac{V_o}{V_i} = \frac{1}{w_i} \arcsin \alpha \quad (8)$$

α is defined as the ratio between the output voltage and the peak of the rectified input voltage. Thus, over half input line cycle, operation is possible only for

$$t \in (t_1, \frac{T_i}{2} - t_1),$$

as shown in **Figure 3**. The average input power with constant duty ratio and constant switching cycle T_s is provided in (9). As referred to (5), the maximum duty cycle D is η for maintaining the converter operate in discontinuous inductor current mode. Substitution of D for η in (9), the following relation can be obtained in (10).

$$P_i = \frac{2}{T_i} \int_{t_1}^{\frac{T_i}{2}-t_1} V_i \sin w_i t \cdot I_{i,avg} dt \quad (9)$$

$$= \frac{V_i^2 D^2 T_s}{4L_2} \left(1 - \frac{2}{\pi} \arcsin \eta - \frac{2\eta\sqrt{1-\eta^2}}{\pi} \right)$$

$$P_i = \frac{V_i^2 \eta^2 T_s}{4L_2} \left(1 - \frac{2}{\pi} \arcsin \eta - \frac{2\eta\sqrt{1-\eta^2}}{\pi} \right) \quad (10)$$

The relation between active input power and conversion ratio η with maximum duty ratio is plotted in **Figure 4**. As shown, with $D = \eta$, the converter operates in the boundary of the discontinuous inductor current mode and the maximum active input power will be obtained when η is near 0.58.

The root mean square value of the input current can be obtained from (7) as

$$I_{irms} = \sqrt{\frac{2}{T_i} \int_{t_1}^{\frac{T_i}{2}-t_1} \frac{(V \sin w_i t - V_o)^2}{2L_2} D^2 T_s dt} \quad (11)$$

$$= \frac{V_i D^2 T_s}{2\sqrt{2}L_2} \sqrt{\left(1 + 2\eta^2 \right) \left(1 - \frac{2}{\pi} \arcsin \eta \right) - \frac{6\eta\sqrt{1-\eta^2}}{\pi}}$$

the power factor is obtained from (10) and (11) as,

$$P.F = \frac{P_i}{V_{irms} \cdot I_{irms}} = \frac{1 - \frac{2}{\pi} \arcsin \eta - \frac{2\eta\sqrt{1-\eta^2}}{\pi}}{\sqrt{\left(1 + 2\eta^2 \right) \left(1 - \frac{2}{\pi} \arcsin \eta \right) - \frac{6\eta\sqrt{1-\eta^2}}{\pi}}} \quad (12)$$

where P.F is the power factor. It is clear that the power factor is affected only by conversion ratio η when the duty cycle D is constant. The relation is plotted in **Figure 5**.

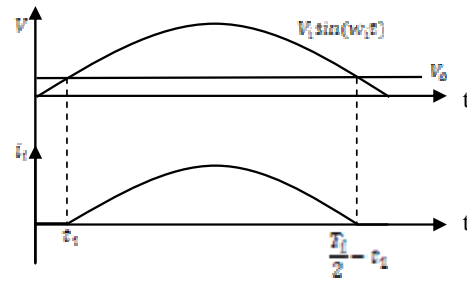

Figure 3. Operation waveforms during half input cycle.

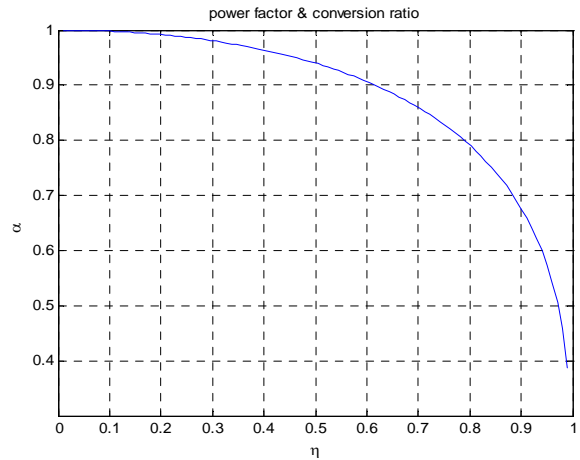

Figure 4. Active Input Power vs Conversion Ratio η (from equation (10)).

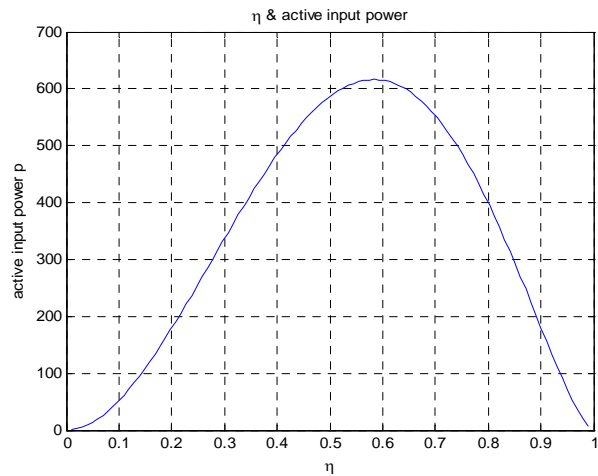

Figure 5. Power Factor vs Conversion Ratio η (from equation (12)).

It is shown that the power factor is reversely proportional to the conversion ratio η .

When $\eta < 0.6$ the power factor will be higher than 0.9. The results are exact the same as [5]. When η is very small, $V_o \ll V_i \sin w_i t$. Then the input current will be

$$I_{i,avg} \approx \frac{V_i \sin w_i t}{2L_2} D^2 T_s \quad (13)$$

The equivalent input impedance is resistive,

$$R_i = \frac{2L_2}{D^2T_s} \quad (14)$$

The power factor turns out to be unity. Therefore, with constant duty cycle D and constant switching cycle T_s , the lower output voltage, the higher power factor.

4. Modeling

The low-frequency model is obtained by considering the relative voltage or current will not change over one switching cycle since the switching cycle is much higher than the input line frequency. Therefore, the average value, over one switching cycle, is considered as an instant value during one switching cycle [4,6]. By assuming that the voltage across C_1 is continuous and constant over a switching cycle, the average switch current i_s and average current through L_2 over one switching cycle can be obtained from **Figure 2**.

$$I_s = \frac{V_2}{2L_2} D_1 D T_s \quad (15)$$

$$I_2 = \frac{V_2}{2L_2} (D_1 + D) D_1 T_s \quad (16)$$

As the average voltage across L_2 is zero over one switching cycle.

$$D_1 = \frac{V_1 - V_2}{V_2} D \quad (17)$$

As shown in **Figure 1**, the following equations can be obtained.

$$I_s(s) = \frac{1}{sL_1} (V_i(s) - V_1(s)) - V_1(s) * sC_1 \quad (18)$$

$$I_2(s) = V_2(s) (sC_2 + \frac{1}{R}) \quad (19)$$

$$V_o(s) = V_2(s) \quad (20)$$

Derivation and Laplace transform of (15) ~ (17) and substitution of the results into (18) ~ (19), the following can be obtained.

$$\begin{cases} \frac{V_o(s)}{V_i(s)} = \frac{(2D_1 + D)D}{\alpha_3 s^3 + \alpha_2 s^2 + \alpha_1 s + \alpha_0} \\ \frac{V_o(s)}{D(s)} = \frac{b_2 s^2 + b_1 s + b_0}{\alpha_3 s^3 + \alpha_2 s^2 + \alpha_1 s + \alpha_0} \end{cases} \quad (21)$$

where,

$$\begin{cases} \alpha_3 = \frac{2L_1 L_2 C_1 C_2}{T_s} \\ \alpha_2 = L_1 C_1 (D_1 + D)^2 + \frac{2L_1 L_2 C_1}{RT_s} + L_1 C_2 D^2 \\ \alpha_1 = \frac{2L_2 C_2}{T_s} + \frac{L_1 D^2}{R} + \frac{T_s L_1 D_1^2 D^2}{2L_2} \\ \alpha_0 = (D_1 + D)^2 + \frac{2L_2}{RT_s} \end{cases}$$

$$\begin{cases} b_2 = 2L_1 C_1 V_2 D_1 \left(\frac{D_1 + D}{D}\right) \\ b_1 = -\frac{V_2 L_1 T_s D D_1^2}{L_2} \\ b_0 = 2V_2 D_1 \left(\frac{D_1 + D}{D}\right) \end{cases}$$

$V_o(s)/V_i(s)$ is output-input transfer function and $V_o(s)/D(s)$ is the output-control transfer function. The transfer function between output voltage and duty cycle given by (21) has three poles and two zeros. This can be approximate to have a single pole which is exactly the same as the traditional Boost converters [6,7].

5. Results

5.1. Simulations

Simulations were carried out to verify the discontinuous inductor current operation of the circuit. The components used are: $L_1 = 500\mu$, $L_2 = 20\mu$, $C_1 = 220n$, $C_2 = 2000\mu$, $D = 0.1$, $R = 13$. The input voltage is 220VAC and the output voltage is 36 V. The results are illustrated as follows (**Figures 6 - 9**), which show that input current will follow the input voltage automatically when Buck converter with an input LC filter operates in discontinuous inductor current with a constant the duty ratio.

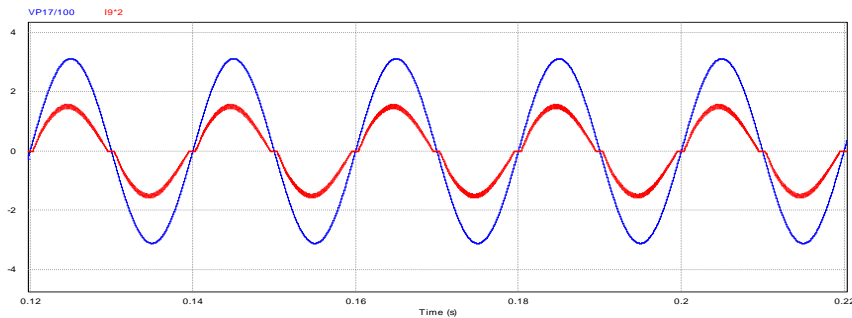

Figure 6. Input voltage and input current (220Vac; 0.52A).

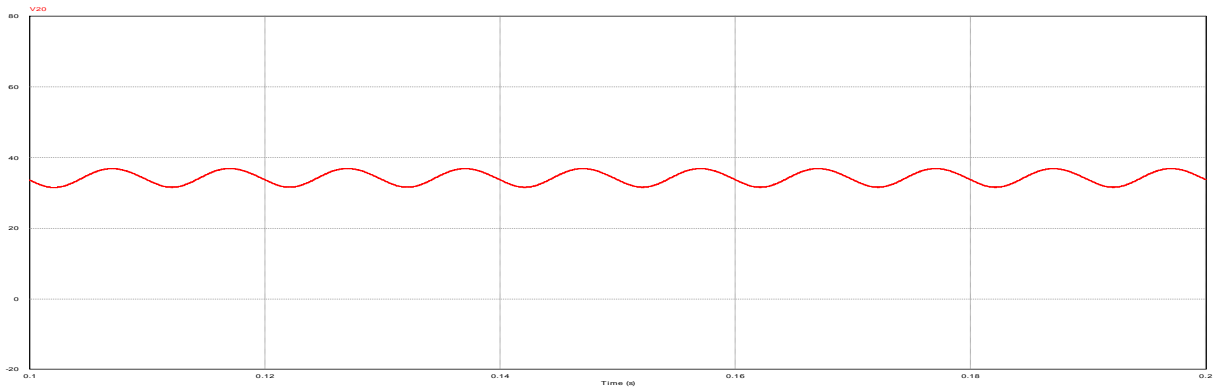

Figure 7. Output voltage: 36v (ripple: 5v),

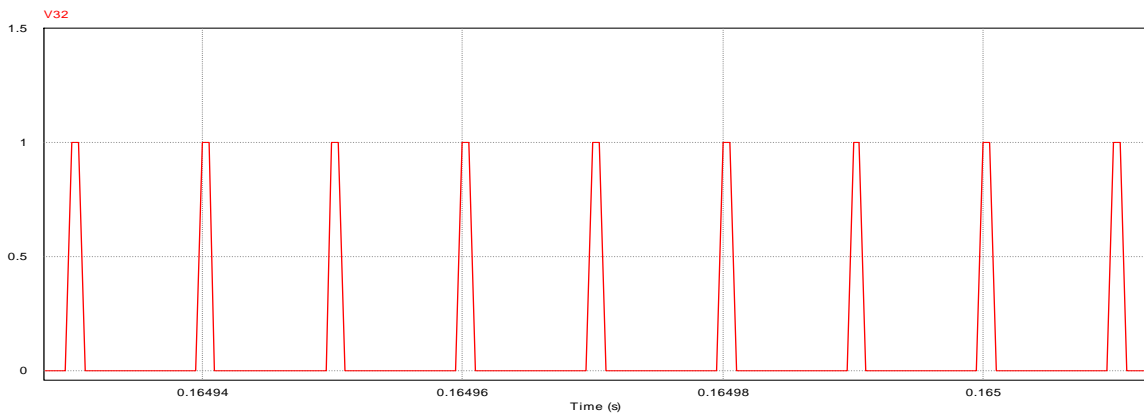

Figure 8. Constant duty cycle (0.15).

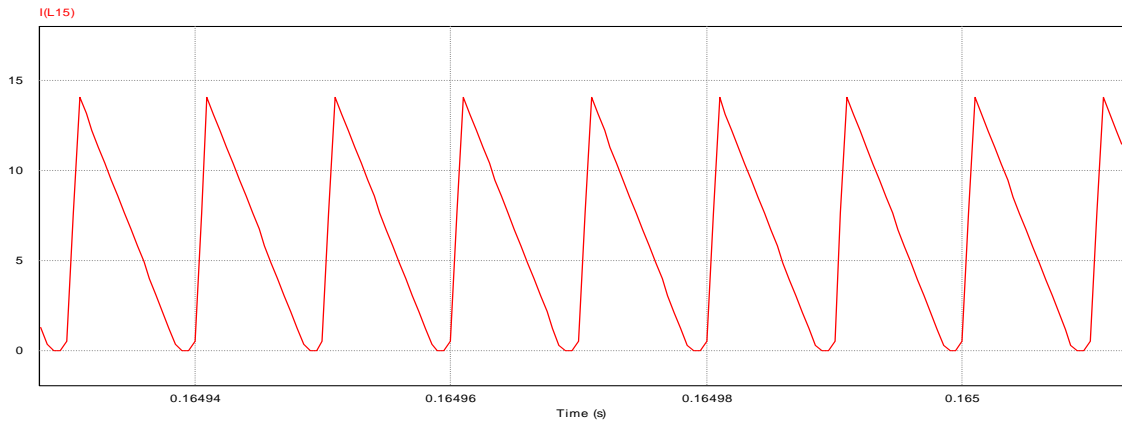

Figure 9. Output inductor current (L2 in Figure 1: DCM).

5.2. Experiments

An experiment circuit was also built and the parameters and the components used is the same as the simulations. The control signal was generated using an UC3854. The results are as follows.

The experimental results are in accordance with the simulations. The input power is 125w and the output power is 100w. Thus the efficiency of the system is 80%.

The power factor is 0.98. As shown in **Figures 10 - 13**, the duty cycle D is a simple constant value to gain a high power factor.

6. Conclusions

The operation and characteristics of the Buck converter with LC input filter operating in discontinuous inductor current mode has been studied.

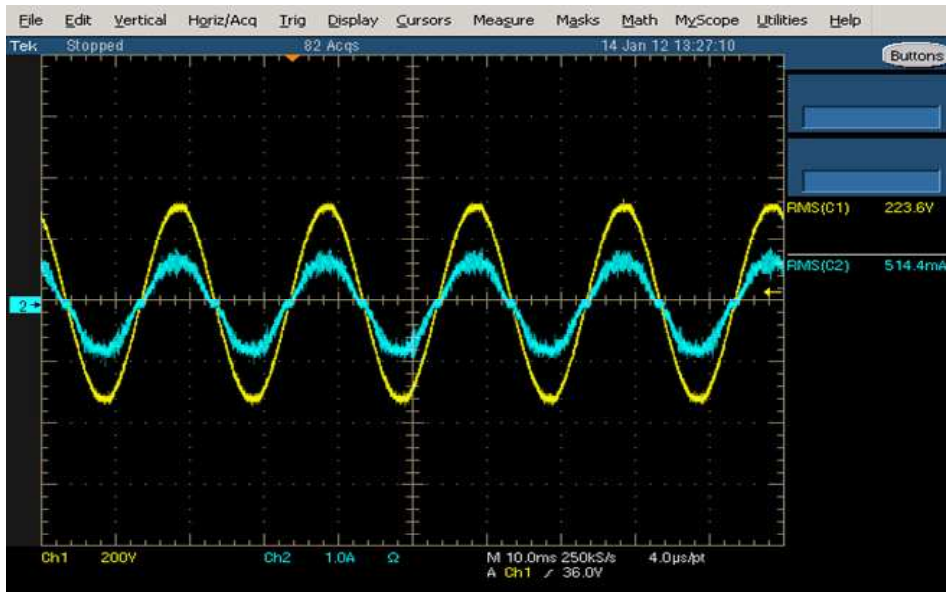

Figure 10. Input Voltage: 220vac Input Current: 0.54mA.

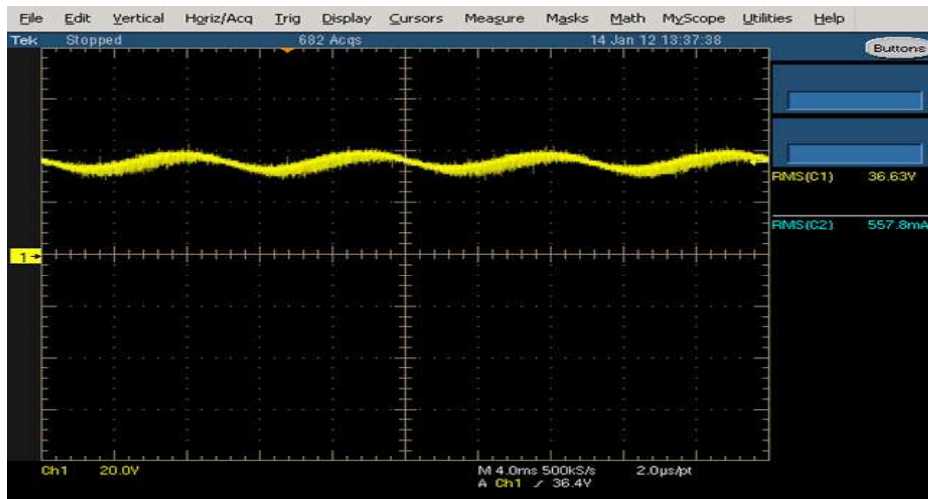

Figure 11. Output voltage: 36VDC (ripple: 5v).

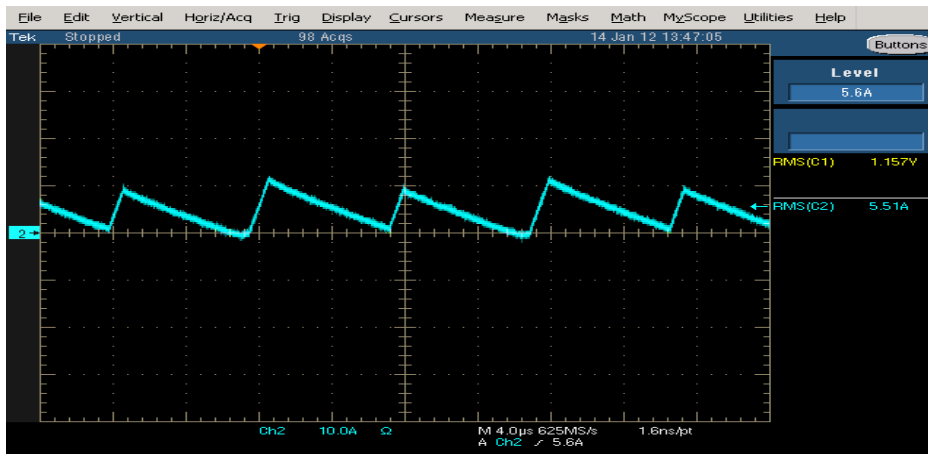

Figure 12. Output inductor current (L2 in Figure 1) DCM.

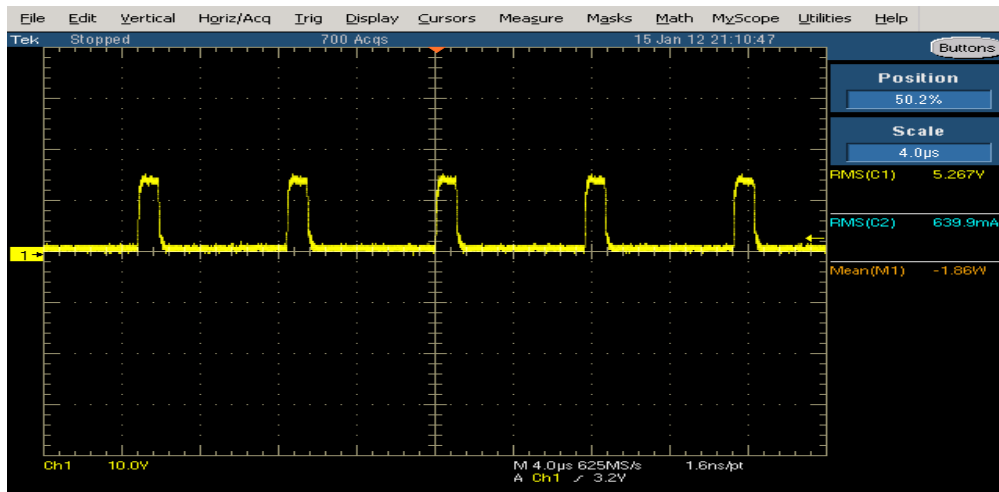

Figure 13. Constant duty cycle.

It is found that the converter can gain a high power factor when the duty ratio maintain constant. A low frequency model of the converter has been developed. A 100w experimental circuit has been built to confirm the theoretical analysis.

REFERENCES

- [1] R. Hammano and R. Neidorff, "Improving Input Power Factor - A New Active Control Simplifies the Task," in *Proceedings of the 19th International PCIM Conference*, 1989.
- [2] R. Keller and G. Baker, "Unity Power Factor Off Line Switching Power Supplies," in *IEEE INTELEC Record*, 1984, pp. 332-339.
- [3] V. Grigore and J. Kyra, "High Power Factor Rectifier Based on Buck Converter Operating in Discontinuous Capacitor Voltage Mode," in *Proc. IEEE Appl. Power Electron. Conf. Expo.*, Mar. 1999, pp. 612-618.
- [4] Y. S. Lee, "Modeling, Analysis, and Application of Buck Converters in Discontinuous-Input-Voltage Mode Operation," *IEEE Trans. Ind. Electron*, Vol. 12, No. 2, 1992.
- [5] H. Endo, T. Yamashim and T. Sugiura, "A High-Power-Factor Buck Converter," *Proc. of the IEEE Power Electronics Specialists Conference*, pp. 1071-1076.
- [6] R. W. Erickson, "Fundamentals of Power Electronics," M, second edition, 2001
- [6] PHILIP C. TODD, "UC3854 Controlled Power Factor Correction Circuit Design," UNITRODE application note, U134.