

Human–Wildlife Interactions 4(2):293–303, Fall 2010

Improved methods for deterring cliff swallow nesting on highway structures

MICHAEL J. DELWICHE, University of California, Department of Biological and Agricultural Engineering, One Shields Avenue, Davis, CA 95616, USA mjdelwiche@ucdavis.edu

ROBERT W. COATES, University of California, Department of Biological and Agricultural Engineering, One Shields Avenue, Davis, CA 95616, USA

W. PAUL GORENZEL, University of California, Department of Wildlife, Fish, and Conservation Biology, One Shields Avenue, Davis, CA 95616, USA

TERRELL P. SALMON, University of California, Department of Wildlife, Fish, and Conservation Biology, One Shields Avenue, Davis, CA 95616, USA

Abstract: Cliff swallows (*Petrochelidon pyrrhonota*) are migratory birds that frequently nest on highway structures, such as bridges. Because cliff swallows are protected by the Migratory Bird Treaty Act of 1918, nesting control methods must not harm cliff swallows or disturb active nests. This can cause delays for maintenance divisions of state departments of transportation, resulting in additional cost. In a multiyear project, we evaluated the effects of bioacoustic deterrents and bridge surface modifications on nesting behavior of cliff swallows. We used cliff swallow alarm and distress calls as bioacoustic deterrents (hereafter, broadcast calls [BC]) because they previously had been shown to delay the onset of nesting. We used low-friction plastic sheeting (PTFE, commonly called by its trade name, Teflon®) and silicone-based paint for bridge surface modification. In 2007, swallows were able to complete nests on silicone paint, but did not successfully complete any nests on PTFE. In 2008, PTFE+BC treatment significantly reduced nesting compared with no treatment, although some nests were completed at PTFE and PTFE+BC sites on the bare concrete next to the sheeting or at locations where sheeting had peeled away. We recommend treatment with PTFE+BC to reduce the likelihood of cliff swallow nesting on bridge surfaces, but this should be supplemented with weekly site visits to check treatment integrity and to remove any partial nests on untreated surfaces.

Keywords: alarm call, bioacoustics, bridge, cliff swallow, distress call, human–wildlife conflicts, nest, *Petrochelidon pyrrhonota*, surface modification, Teflon, transportation

CLIFF SWALLOWS (*Petrochelidon pyrrhonota*) are protected by the Migratory Bird Treaty Act of 1918. Completed nests cannot be disturbed during the breeding season, which is considered by the California Department of Fish and Game to be February 15 to September 1. The original nesting habitat of cliff swallows was on rocky cliffs (Emlen 1954) of foothills and mountains, but their breeding season range has significantly expanded over the last 50 to 100 years because of the construction of bridges, culverts, dams, and buildings that serve as surrogates for cliffs (Brown and Brown 1995). At present, the breeding season range extends north to Alaska, south through Mexico, and east through the southern coastal states (Tumlinson 2009). Nesting under bridges (Figure 1) and other highway structures creates challenges for state departments of transportation because construction, maintenance, and repair cannot be performed during the breeding season. Netting is sometimes used to prevent nesting by exclusion, but this is an expensive control

method and has resulted in the occasional trapping and inadvertent killing of swallows. Alternative methods of control are needed by departments of transportation to deter cliff swallows from nesting under bridges.

In the initial phase of this research project, we considered several potential methods of cliff swallow deterrence, including chemical, visual, and auditory deterrents, habitat modification, and exclusion (Gorenzel and Salmon 1982, Salmon and Gorenzel 2005). We selected the most promising nonlethal deterrents (i.e., surface modification with plastic sheeting and broadcast alarm and distress calls). These methods were based on ease of installation, cost, and maintenance. We conducted field trials during 2006 to determine the effectiveness of these 2 methods. We used high-density polyethylene (HDPE) sheeting to cover bridge pier walls and piles where cliff swallows were likely to build nests. The hypothesis was that nests would not adhere to the HDPE surface because of its low coefficient

of friction. In addition, electronic devices played cliff swallow alarm and distress calls to reduce their desire to nest at that location. The results showed HDPE and alarm and distress calls were able to reduce the total number of completed nests compared to control sites, and HDPE was more effective than bioacoustics (Conklin et al. 2009). However, neither method alone or in combination produced complete deterrence, the ideal goal of departments of transportation.

In the second and final phase of this research project, we evaluated several different materials for surface modification, either alone or in combination with cliff swallow alarm and distress calls. The hypothesis was that sites treated with both surface modifications and broadcast calls would have fewer completed nests compared to untreated sites. Our objective was to evaluate the most promising deterrence strategies for bridges and to recommend the best approach for future implementation by state departments of transportation.

Materials and methods

Surface modification

In our initial field study conducted on bridges, HDPE was shown to reduce the number of cliff swallow nests built at a site, but it did not completely prevent nesting because after repeated attempts the birds were able to stick mud to the surface. We believed that HDPE did not provide a slick enough surface to prevent nest adhesion, which should be indicated by the appropriate frictional parameter. The coefficient of friction, μ , between 2 solid surfaces is the ratio of the frictional force to the normal force and is measured for either the static situation (μ_s), where the surfaces are just at the point of sliding, or the dynamic case (μ_d), while the surfaces are sliding. We found nominal values of μ_s from commercial sources to compare the friction between general types of plastic and a reference surface (in this case steel), including $\mu_s = 0.4$ for acrylic, $\mu_s = 0.2$ for polyethylene, and $\mu_s = 0.04$ for polytetrafluoroethylene (PTFE, i.e., Teflon®). A variety of specialized polyethylenes are available, including HDPE and ultra-high molecular weight polyethylene (UHMW) that produce less friction than low-density polyethylene, but we could not find values of μ_s for these materials. Comparison of the dynamic



Figure 1. Partial (left) and completed cliff swallow nests on the underside of a bridge.

friction coefficients, μ_d , indicated decreased frictional (i.e., sliding) forces for increased density, but none of the polyethylenes gave frictional forces as low as PTFE. These data suggested that PTFE would inhibit successful nest building more than the polyethylenes.

To verify the selection of material before field-testing, we hung sample sheets of HDPE, UHMW, and PTFE on a vertical wall in our lab. We mixed remnants from cliff swallow nests with water to create mud to mimic that used by the birds. Four pellets of mud (approximately 1 cm³) were pressed onto each of the clean sheets. While they were drying, the mud pellets slid down all of the plastic surfaces. The distance that the mud traveled was greatest on PTFE, followed by UHMW and HDPE. After the mud had dried for about 1 day, we applied an upward tangential force to the mud using a compression spring scale, and we noted the approximate force required to dislodge the pellet. We found that the least force was required to dislodge mud on PTFE, followed by UHMW and HDPE. One pellet self-dislodged from PTFE before our measurements. Based on these observations and the coefficients of friction, we selected PTFE for surface modification testing.

We used sheets of virgin Teflon, 0.254 mm thick and 61 cm wide (TFV-.01-R24, Plastics International, Eden Prairie, Minn.) that we cut with hooked razor blades from 30-m rolls to the appropriate size. The 0.24 mm (10 mil) thickness was chosen since it was the lightest and least expensive material that we felt could withstand handling without tearing during installation.

Another approach to surface modification came from our survey of departments of transportation in the United States, from which we received reports that silicone-based, anti-

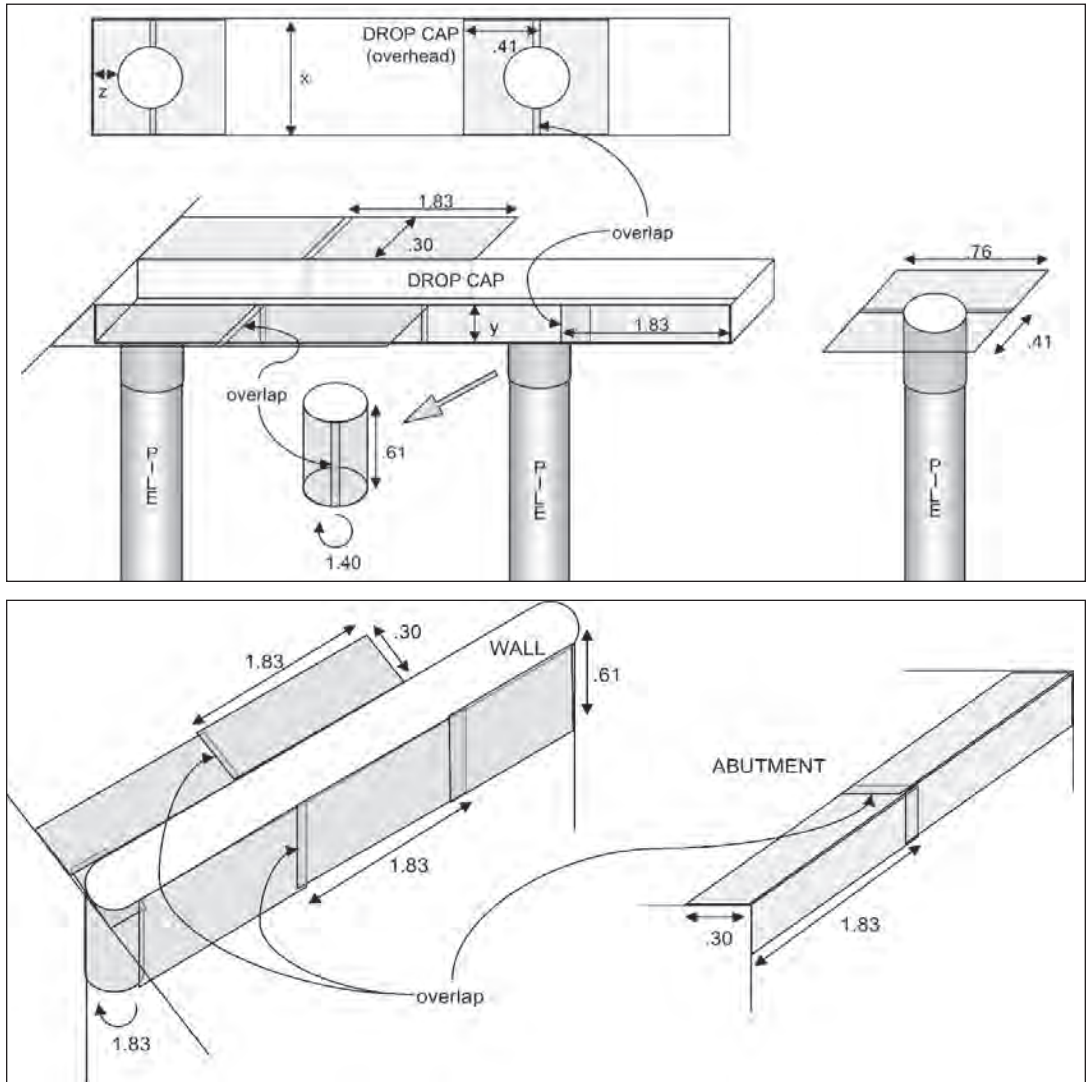

Figure 2. Locations of surface modifications on highway structures with piles and pier walls. Dimensions x, y, and z (top) varied depending on the site. Dimensions in meters; not to scale.

graffiti and anti-corrosion paints (Si-COAT 530 and 579, CSL Silicones, Guelph, Ontario, Canada) might prevent cliff swallow nesting. These materials were described as 1-part room-temperature vulcanizing organosiloxane-polysiloxane coatings. We conducted similar preliminary tests to determine whether to use Si-COAT 530 or 579 in the field. We applied both paints to separate faces of a concrete block. We pressed 4 mud pellets onto each of the painted surfaces and the unpainted concrete surface. All mud pellets self-dislodged from the painted surfaces, but they required considerable force to dislodge from the unpainted surface. We selected Si-COAT 530 ultimately for field-

testing because it had a translucent appearance, which was more desirable than the grey color of Si-COAT 579.

We applied both PTFE and silicone paint to the undersurface of bridges where nests are commonly built, such as at the juncture of vertical and overhead surfaces. For the bridges in our study, this included the upper portion of pier walls and piles, the surface above piles and walls, and the vertical and overhead juncture of drop caps (Figure 2). Based on the nesting attempts we observed in 2007, the vertical and overhead juncture of abutments were treated in 2008. We cleaned the bridge surfaces using metal paint scrapers to remove old nest remnants and



Figure 3. Highway structure with PTFE surface modification.

then pressure-washed with water to remove dust and debris that would reduce adhesion of the treatment materials. Control sites in the field studies only were scraped.

We attached PTFE sheets with a butyl sealant used in roof construction (Panlastic Bead Sealant with Nylon Cubes, #25390, Butler Manufacturing Company, Kansas City, Mo.), the same material used in the initial phase of the project (Conklin 2007). This material acted like an adhesive putty upon which to attach the sheeting to the bridge; it was removable at the end of the study, as required by our county bridge permits.

Table 1. Description and source of the cliff swallow call sequences used in the broadcast call units.

Call	Description and source ^a
1	Cliff swallow held by legs giving distress call (UCD-4A)
2	Multiple cliff swallow alarm calls (BLB-28435)
3	Cliff swallow held by legs giving distress call (UCD-6A)
4	Colony of cliff swallows giving multiple calls (LNS-118832) + 2 cliff swallow alarm call sequences (LNS-73817)
5	Cliff swallow held by legs giving distress call (UCD-7A)
6	Cliff swallow held by legs giving distress call (UCD-9A)
7	Colony of cliff swallows giving multiple alarm calls (LNS-118832) + individual cliff swallows giving alarm calls (LNS-104564)
8	1–2 cliff swallows giving alarm calls, flying by and flying away (LNS-111063)

^a LNS prefix: Macaulay Library of Natural Sounds, Cornell Lab of Ornithology, Ithaca, New York. BLB prefix: Borror Laboratory of Bioacoustics, Ohio State University, Columbus, Ohio. UCD prefix: University of California, Davis, California (new distress calls for 2008).



Figure 4. Highway structure with silicone paint surface modification.

PTFE sheets used for surfaces above pier walls and drop caps were 61-cm wide for sites in 2007 and the first few bridges in 2008, after which we reduced the sheet width to 30 cm for the remaining bridges. PTFE extended 61 cm down each pile and at least 18 cm from the overhead juncture above the pile. We limited the length of sheets to 1.83 m for ease of handling. We applied the butyl adhesive strips along the edges and interior of each sheet so that any point on the sheet was no farther than 15 cm from an adhesive strip. We removed the paper backing of the butyl strips and pressed the sheets against the bridges' surfaces (Figure

3). We overlapped sheets 3 to 6 mm to provide continuous coverage of each surface with PTFE.

We applied silicone paint at locations similar to the PTFE placement, extending it 61 cm down piles and 46 cm out on the overhead surface (Figure 4). We also covered up the surface around drop caps up to 46 cm out from the juncture. We stirred the paint for 2 minutes, then applied it to the surfaces using 1.9-cm nap paint rollers and paint brushes for the corners. The paint cured within several hours of application.

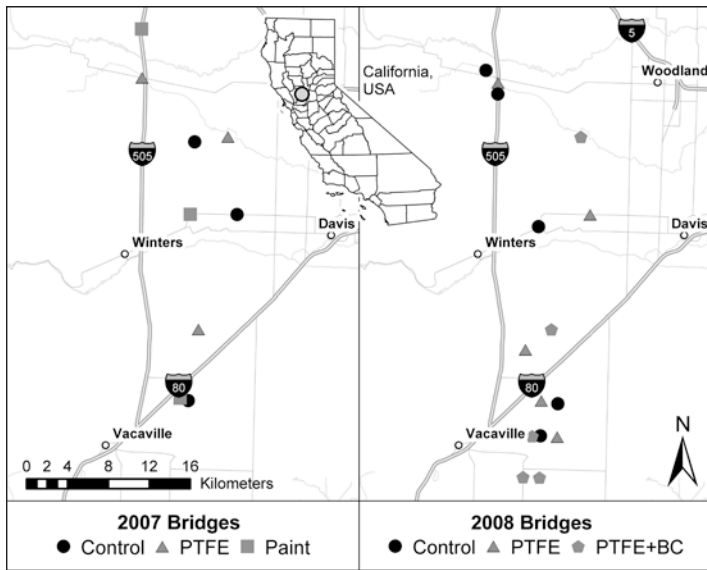

Figure 5. Map of the 2007 and 2008 bridge site locations in proximity to the University of California–Davis and the associated treatment assignments.

Bioacoustics

We found broadcast calls to have a deterrent effect in 2006 (Conklin et al. 2009), so we tested them again. We modified the selection of calls to include distress calls that we recorded in 2006 from cliff swallows that were being banded. These analog recordings were digitized, mixed, clipped to 26 seconds in duration, loaded onto broadcast call units, and operated in the field study as before (Conklin et al. 2009). We installed the broadcast units at the test sites as previously described, except that we placed PTFE sheeting over the plumber's tape to reduce the likelihood of nests being started on the rough surface of the tape. We used 8 call sequences in 2008 (Table 1) including 4 calls from the 2006 study and 4 new distress call sequences.

Experimental design

The 2007 and 2008 field studies were completely randomized designs, with 9 bridge sites in 2007 and 15 sites in 2008 (Table 2). We randomly selected sites from state and county bridges within 40 km of the main campus of the University of California at Davis that satisfied the following criteria: <40 m in length, over water, supported by pier walls or piles, showed evidence of previous colonies (nests or mud remnants), provided safe access, were ≥ 0.1 km from the nearest residential property (with a limit of 1 property in the vicinity), and

were not adjacent to another bridge (Conklin 2007). To allow random assignment, we also added the criterion that sites must be capable of receiving any treatment.

We randomly assigned 3 treatments to sites in each field study (Figure 5). Treatments in 2007 were PTFE surface modification, silicone paint surface modification, and control (untreated). Treatments in 2008 were PTFE surface modification, PTFE surface modification plus broadcast calls (PTFE+BC), and control (untreated). We installed the treatments in the early spring, shortly before or at about the

same time cliff swallows arrived to nest. We visited each site weekly to count the number of cliff swallows and completed nests over 9 weeks in 2007 and 11 weeks in 2008. When the number of nests asymptotically reached a maximum, we considered nest building to be finished for the season and used the number of completed nests from this single site visit for consideration with analysis of variance (ANOVA). We analysed data with SAS (SAS Institute, Cary, N.C.).

Our hypothesis was that sites treated with PTFE, silicone paint, or broadcast calls would have fewer completed nests compared to untreated sites. We modeled the number of completed nests, Y_{ij} as

$$Y_{ij} = \mu + \alpha_i + \varepsilon_{ij} \quad (1)$$

where μ was the mean number of completed nests, α_i the treatment factor, and ε_{ij} the error term. This is the model for a completely randomized 1-way design.

The error terms for each model were assumed to be independent, normally distributed, and to have equal error variances. Although normality was marginally satisfied, error variances were unequal across treatments. Consequently, we transformed Y to satisfy the model assumptions, using

$$Y' = (Y + k)^\lambda \quad (2)$$

Table 2. Characteristics of bridges within 40 km of the University of California at Davis used in the 2007 and 2008 field studies.

2007 Field study							
Bridge no.	Bridge name	Treatment	Date scraped	Washed	Installation	Nest locations ^b	
22C0080	Dry Slough	Control	04/03/07	04/03/07	--	10 piles, 2 drop caps	
22C0122	South Fork Willow Slough	PTFE	04/03/07	04/03/07	04/04/07	5 piles	
22C0045	Chickahominy Slough	Paint	04/03/07	04/03/07	04/05/07	12 piles	
22C0149	South Fork Willow Slough	Control	04/04/07	04/04/07	--	5 piles, 2 pier walls	
22 0028	South Fork Willow Slough	PTFE	03/16/07 ^a	04/10/07	04/12/07	14 piles	
22C0073	Long Creek	Paint	03/16/07 ^a	04/10/07	04/13/07	15 piles	
23C0188	Gibson Canyon Creek	Control	04/06/07	04/06/07	--	5 piles, 1 drop cap	
23C0194	McCune Creek	PTFE	03/16/07 ^a	04/10/07	04/12/07	8 piles	
23C0125	Gibson Canyon Creek	Paint	04/05/07	04/05/07	04/09/07	5 piles, 1 drop cap	
2008 Field study							
22C0145	South Fork Willow Slough	Control	02/21/08	--	--	10 piles, 2 drop caps	
22C0037	South Fork Willow Slough	PTFE	03/10/08	03/10/08	03/27/08	8 piles	
23C0207	New Alamo Creek	PTFE+BC	03/11/08	03/11/08	04/09/08	2 pier walls	
23C0189	Gibson Canyon Creek	Control	02/21/08	--	--	2 pier walls	
23C0199	Sweeney Creek	PTFE	02/21/08	03/07/08	04/04/08	10 piles	
22C0122	South Fork Willow Slough	PTFE+BC	03/10/08	03/10/08	03/27/08	5 piles	
22C0044	Dry Slough	Control	03/07/08	--	--	12 piles	
23C0188	Gibson Canyon Creek	PTFE	02/21/08	03/10/08	04/10/08	5 piles, 1 drop cap	
23C0169	New Alamo Creek	PTFE+BC	02/21/08	03/11/08	04/09/08	2 pier walls	
22C0036	Cottonwood Slough	Control	02/21/08	--	--	8 piles, 2 drop caps	
23C0116	Ulatis Creek	PTFE	02/21/08	03/11/08	04/02/08	2 pier walls	
23C0194	McCune Creek	PTFE+BC	03/07/08	03/07/08	03/28/08	8 piles	
23C0200	Ulatis Creek	Control	03/10/08	--	--	2 pier walls	
22C0080	Dry Slough	PTFE	02/21/08	03/07/08	04/01/08	10 piles, 2 drop caps	
23C0166	Ulatis Creek	PTFE+BC	03/10/08	03/10/08	04/08/09	2 pier walls	

^aSite scraped multiple times thereafter until washed or installation.

^bRefer to Figure 2 for explanation of pile, drop cap, and pier wall.

where Y' was the transformed dependent variable, λ was the exponent for transformation, and k was a constant added to account for instances of $Y = 0$ in the data. We selected a nominal value of $k = 1$, and we tested values of λ between -2 and 2 in increments of 0.5. We determined that the most improvement in error variance equality was provided by $\lambda = 0.5$ for the 2007 data set and $\lambda = -1$ for the 2008 data set. We further stabilized the error variance by using a weighted least-squares analysis with a weight equal to the reciprocal of the variance of each treatment level of Y' . For the transformed and weighted least-squares ANOVA results, error terms did not violate the assumptions of normality or equal error variance. We used F-statistics and Tukey's multiple comparison procedure (Neter et al. 1996) to make inferences about the treatment effects. (Note that in order to accomplish weighted least-squares analyses,

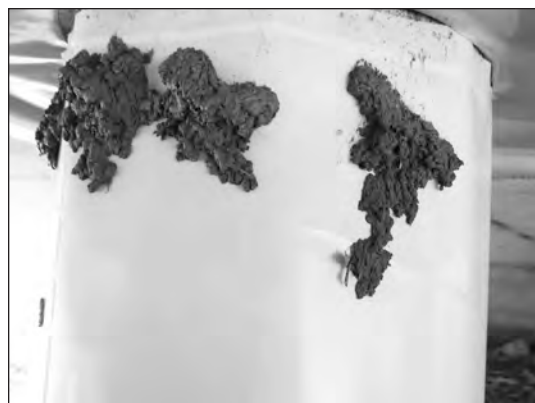

Figure 6. Nest mud sliding down surface of PTFE on a pile.



Figure 7. Completed nests on piles and overhead surfaces treated with silicone paint.

nest counts of 0 were changed to 1 to produce non-zero treatment variances and allow weighted least-squares calculations. These modifications of the data had no appreciable effect on the statistical conclusions.)

Animal use and care in this project was approved by Institutional Animal Care and Use Committee of the University of California, Davis, under protocol #11976.

Results

Surface modifications (2007)

We found completed nests at 6 of 9 sites by the end of 9 weeks in 2007. Two of the unoccupied sites were treated with PTFE, and one was treated with silicone paint. No nests were successfully completed on any of the PTFE surfaces, although several attempts were made (Figure 6). Cliff swallows were able to complete nests on the silicone paint (Figure 7). By the end of the study, 1 paint-treated site had 40 completed nests on painted surfaces and another site had 214 completed nests on painted surfaces. All control sites were occupied, with 132 completed nests at the smallest of the 3 colonies. Seven nests were completed on the untreated abutment of a PTFE-treated site, but these nests were washed away by high water in the sixth week. Because there was no evidence of prior nesting at this location, we decided to treat the abutments in 2008.

Nest building ceased at all sites by week 7 of the study, so we used nest counts from the seventh survey for statistical comparison. The mean number of completed nests (Figure 8) for each type of treatment was: PTFE (0), silicon paint (85), and control (348). Statistical tests indicated that the treatment means were not equal ($P = 0.006$) and the PTFE and control treatments means differed ($\alpha = 0.05$).

Surface modifications and broadcast calls (2008)

All 5 control sites were colonized in 2008, although 1 site had a maximum of only 7 completed nests over the 11-week test period. For the 5 PTFE treatments, 1 site had no completed nests, 1 site had 2 nests, and the other 3 sites had >80 nests each. For the 5 PTFE+BC treatments, 1 site had no nests, 2 sites had 3 and 4 nests (respectively), 1 site had 46 nests, and 1 site had 146 nests. All completed nests

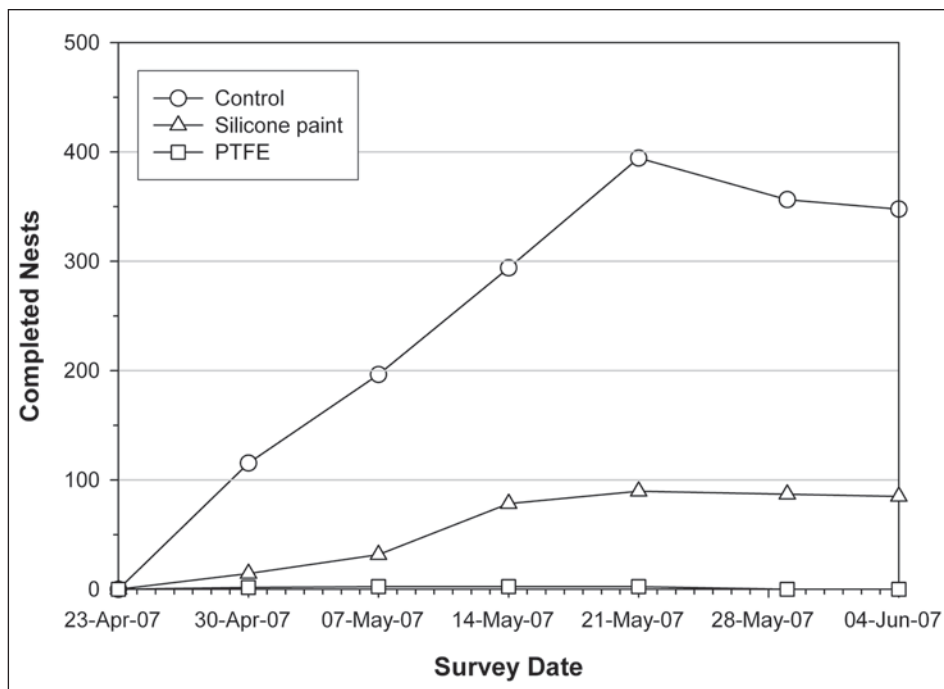

Figure 8. Average number of completed nests over 7 weeks in 2007.

at either PTFE or PTFE-BC sites were found on bare concrete. To be consistent with the 2007 analysis, we decided to do the statistical analysis on nest counts collected during the seventh survey and also because the PTFE sheeting was detaching from the bridge surfaces and could not be replaced quickly enough to maintain the integrity of the treatments. Furthermore, nest building at control sites had virtually ceased by the seventh week. Average completed nests over time for each treatment in 2008 are shown in Figure 9. At the seventh survey, the mean number of completed nests was 1 for PTFE+BC, 52 for PTFE, and 196 for the control. Statistical tests indicated that the treatment means were not equal ($P = 0.002$) and the PTFE+BC and control treatment means differed ($\alpha = 0.05$).

Discussion

We found that surface preparation, cutting the sheets of PTFE, and installation with butyl adhesive required substantial effort. Silicone paint required less effort to install than PTFE because the material preparation tasks were eliminated. Broadcast alarm–distress calls alone were the easiest to implement, but our previous results showed them to be less effective than surface modifications (Conklin et al. 2009). The

2007 field tests showed that PTFE was effective at preventing successful completion of nests. Our findings also suggest that treatment with silicone paint reduced nesting, but more replications would have been needed to demonstrate significance. Contrary to our preliminary experiments in the lab, mud stuck to the painted surfaces in the field and allowed some nest completion. We suspect that repeated attempts at nest building abraded the paint surface enough to allow eventual completion. We observed a similar effect on HDPE surfaces in the field tests of 2006 (Conklin et al. 2009). Therefore, we do not recommend silicone paint as a deterrent method for cliff swallow nesting.

No cliff swallow nests were completed on the PTFE sheets in 2007, although swallows made several attempts. The only completed nests in the study were found on an abutment with no prior evidence of nesting. This prompted us to treat abutments in our 2008 study. Nine PTFE sheets became detached from bridge surfaces in the last few weeks of the 2007 study, and we did not feel this would be a major problem in 2008, but we were wrong.

Analysis of the 2008 field data showed that only the PTFE+BC treatment differed from the control (i.e., untreated concrete). We believe

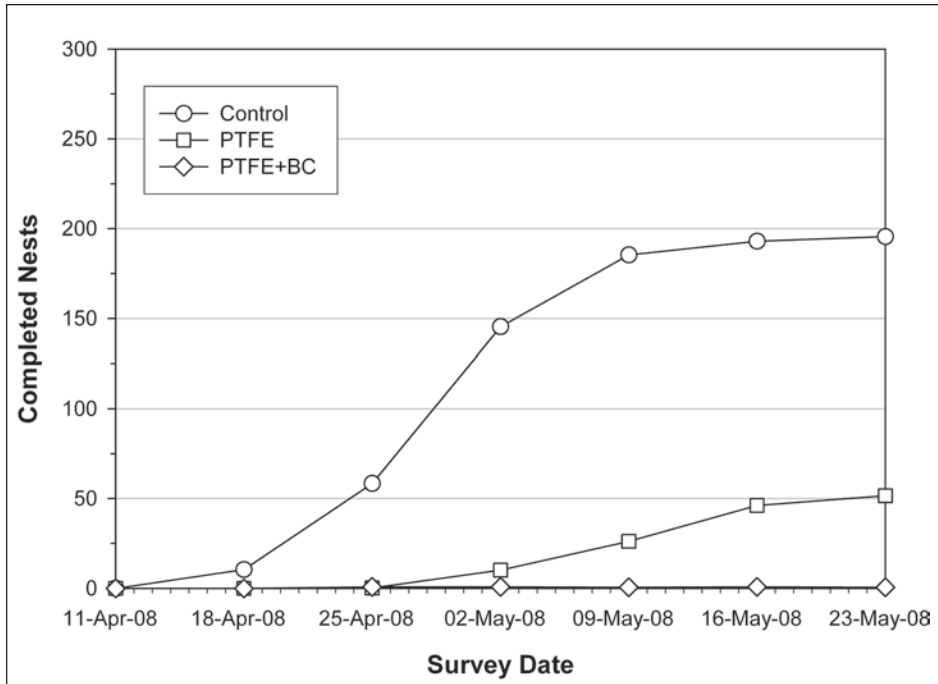

Figure 9. Average number of completed nests over 7 weeks in 2008.

that both the PTFE and PTFE+BC treatments would have been more effective if it were not for problems with PTFE sheet adhesion to the bridge surface (Figure 10). Many of the detached sheets were installed overhead, such that the weight of the sheet pulled directly away from the bridge surface. We replaced missing PTFE sheets as quickly as possible during the first 7 weeks of the study, but at some sites we were unable to replace the sheets before the birds had built nests at that location. We included these nests in our counts, but they do not reflect the intrinsic ability of PTFE to deter nesting, assuming it is securely attached to the surface. Butyl adhesion failed at the concrete surface and at the PTFE surface in about equal proportions. This suggests that butyl sealant is not adequate for reliable surface modification treatments as conducted in this study. Thinner or smaller sheets of PTFE, or additional strips of butyl adhesive might prevent detachment from the bridge surface, but we feel that a better attachment method is needed, such as mechanical fasteners or semi-permanent epoxy adhesive.

We also observed a tendency for cliff swallows to build nests in unusual locations at PTFE-treated bridges. We found completed

nests on the vertical surfaces below the edge of PTFE sheets and on the overhead surfaces along seams in the concrete. These nests were included in the count data and reflect the actual effectiveness of PTFE to deter cliff swallow nesting when used only at typical nesting locations (e.g., Figure 2).

Because cliff swallow nests were not completed on PTFE surfaces in the 2007 and 2008 studies, we feel the material would be useful to state departments of transportation for nesting prevention. However, improved attachment methods need to be developed to ensure treatment reliability. Without surface modification of all bridge surfaces, our results indicate that it may be difficult to provide 100% effectiveness because birds may nest at locations where they would not do so otherwise.

We recommend treating all junctures of a structure (as was done in this research) to provide at least a minimum level of deterrence. Treating all vertical surfaces to within 61 cm of the ground (approximate level at which birds would be concerned about predators) would provide more effective deterrence. Lastly, unusual surface features, such as seams, cracks, lumps, bolts, and brackets should be treated for even greater deterrence. Only complete



Figure 10. PTFE sheets detaching from the concrete bridge surface and cliff swallows building nests.

coverage of a bridge surface with PTFE and reliable attachment methods would likely be 100% effective. It would also be worthwhile to seek other paint-like materials that could mimic the low-friction properties of PTFE.

Treatment with broadcast calls and PTFE was shown to improve the deterrence of nesting compared to PTFE alone. It is difficult to say whether this effect would be evident in the absence of the PTFE surface attachment problems. Our 2006 study showed that broadcast calls delayed nesting onset and reduced the number of nests completed at a site. Because the 2006 study used HDPE on which birds successfully built nests and the 2008 study used PTFE on which birds were not able to build nests, we would expect to see less difference between PTFE and PTFE+BC treatments compared to the difference between HDPE and HDPE+BC treatments. The main benefit of broadcast calls at PTFE-treated sites would likely be in reduced nesting on untreated, unusual nesting locations within or near the treatment area. We noticed that birds built nests on top of the broadcast call units during the 2006 and 2008 studies, indicating habituation to the hazing and demonstrating their overriding desire to nest.

Conclusions

Cliff swallows are a problem for state departments of transportation because they frequently colonize highway structures, and their nests cannot be disturbed until the nesting season has ended. The number of nests completed at bridge sites was reduced by using surface modification with PTFE (Teflon) plastic sheeting and silicone-based paint at preferred

nesting locations, plus broadcast alarm-distress calls. Swallows were eventually able to complete nests on silicone paint, but did not successfully complete nests on PTFE. Nests built at sites treated with PTFE or PTFE+BC were never started on the PTFE sheeting itself, but instead on bare concrete next to the sheeting or at a location where sheeting had peeled away from the surface. PTFE treatment would likely have been more effective in our field studies if we had a better method of attachment than butyl sealant. Broadcast calls reduced the number of completed nests by delaying the onset of nest building. Even though broadcast calls did not completely eliminate nesting, this treatment is much easier to apply than surface modifications. We recommend treatment with PTFE and broadcast calls to reduce the likelihood of cliff swallow nesting on bridge surfaces. This should be supplemented with weekly site visits to check treatment integrity and remove any partial nests not on the treated surfaces.

Acknowledgments

This research was partially supported by the California Department of Transportation. We thank S. Upadhyaya for help with the data analysis.

Literature cited

- Brown, C. R., and M. B. Brown. 1995. Cliff swallow (*Hirundo pyrrhonota*). In A. Poole and F. Gill, editors. The birds of North America, no. 149. Academy of Natural Sciences, Philadelphia, Pennsylvania, USA, and American Ornithologists' Union, Washington, D.C., USA.
- Conklin, J. S. 2007. Aversion strategies for cliff swallow nesting on bridges using bioacoustics

and surface modifications. Thesis, Department of Biological and Agricultural Engineering, University of California, Davis, California, USA.

Conklin, J. S., M. J. Delwiche, W. P. Gorenzel, and R. W. Coates. 2009. Detering cliff swallow nesting on highway structures using bioacoustics and surface modifications. *Human–Wildlife Conflicts* 3:93–102.

Emlen, J. T., Jr. 1954. Territory, nest building, and pair formation in the cliff swallow. *Auk* 71:16–35.

Gorenzel, W. P., and T. P. Salmon. 1982. The cliff swallow—biology and control. *Vertebrate Pest Conference* 10:179–185.

Neter, J., M. H. Kutner, C. J. Nachtsheim, and W. Wasserman. 1996. *Applied linear statistical models*. Fourth edition. McGraw-Hill, New York, New York, USA.

Salmon, T. P., and W. P. Gorenzel. 2005. Cliff swallows. *University of California Agriculture and Natural Resources Publication 7482*, <<http://www.ipm.ucdavis.edu/PMG/PESTNOTES/pn7482.htm>>. Accessed March 26, 2010.

Tumilson, R. 2009. Breeding by cliff swallows (*Petrochelidon pyrrhonota*) in southern Arkansas. *Southwestern Naturalist* 54:208–210.

MICHAEL J. DELWICHE is a professor and chair in the Department of Biological and Agricultural Engineering at the University of California–Davis. He earned his undergraduate and graduate degrees at Cornell University, worked at Clemson University, and joined the faculty at the University of California–Davis in 1986. His general area of research is bioinstrumentation and control, with current projects in biosensor development, sensor systems for precision field control, and biological control of plant pests.



ROBERT W. COATES earned his B.S. and M.S. degrees from the University of California–Davis, with a major in biological systems engineering and a minor in computer science. He currently works as an associate development engineer in the Department of Biological and Agricultural Engineering at the University of California–Davis. He has designed and implemented systems for wireless control and sensing in irrigation, GPS-guided soil fumigation, cliff swallow nesting deterrence on highway structures, and wild turkey deterrence in vineyards.



W. PAUL GORENZEL received B.S. and M.S. degrees in wildlife biology, from the University of Massachusetts and Colorado State University, respectively. He has worked at the University of California–Davis both as a staff research associate for wildlife extension and the Department of Wildlife, Fish, and Conservation Biology since 1979. His professional interests include wildlife damage management and the development of a program for hazing birds at oil spills.



TERRELL P. SALMON earned his Ph.D. degree in ecology from the University of California–Davis. He has been a wildlife specialist for University of California Cooperative Extension for over 30 years. His research focus is on wildlife–human conflicts with emphasis on rodents and birds as they impact agricultural crops, structures and natural resources.

