

Utah State University

DigitalCommons@USU

---

All Graduate Theses and Dissertations

Graduate Studies

---

5-2017

# Optimization of Roadway Electrification Integrating Wireless Power Transfer: TechnoEconomic Assessment and Lifecycle Analysis

Braden J. Limb  
*Utah State University*

Follow this and additional works at: <https://digitalcommons.usu.edu/etd>



Part of the [Automotive Engineering Commons](#)

---

## Recommended Citation

Limb, Braden J., "Optimization of Roadway Electrification Integrating Wireless Power Transfer: TechnoEconomic Assessment and Lifecycle Analysis" (2017). *All Graduate Theses and Dissertations*. 5261.

<https://digitalcommons.usu.edu/etd/5261>

This Thesis is brought to you for free and open access by the Graduate Studies at DigitalCommons@USU. It has been accepted for inclusion in All Graduate Theses and Dissertations by an authorized administrator of DigitalCommons@USU. For more information, please contact [digitalcommons@usu.edu](mailto:digitalcommons@usu.edu).



OPTIMIZATION OF ROADWAY ELECTRIFICATION INTEGRATING WIRELESS  
POWER TRANSFER: TECHNO-ECONOMIC ASSESSMENT AND LIFECYCLE  
ANALYSIS

by

Braden J. Limb

A thesis submitted in partial fulfillment  
of the requirements for the degree

of

MASTER OF SCIENCE

in

Mechanical Engineering

Approved:

---

Jason C. Quinn, Ph.D.  
Major Professor

---

Robert E. Spall, Ph.D.  
Committee Member

---

Regan A. Zane, Ph.D.  
Committee Member

---

Mark McLellan, Ph.D.  
Vice President for Research and  
Dean of the School of Graduate Studies

UTAH STATE UNIVERSITY  
Logan, Utah

2016

Copyright © Braden Jeffery Limb 2016  
All Rights Reserved

## ABSTRACT

Optimization of Roadway Electrification Integrating Wireless Power Transfer: Techno-  
Economic Assessment and Lifecycle Analysis

by

Braden J. Limb, Master of Science

Utah State University, 2016

Major Professor: Dr. Jason C. Quinn  
Department: Mechanical and Aerospace Engineering

The transportation sector is one of the primary consumers of fossil fuels in the United States each year, accounting for 27.7% of the total energy and 78% of the petroleum used annually. Drive to reduce fossil fuel dependence has resulted in the need for alternative vehicle technologies. Electric vehicles are one of the primary alternatives currently being pursued, however their acceptability is closely related to their range and purchase cost. The main component that contributes to range and cost is the battery. Increase in battery size results in more range, but also increases the cost and weight of the vehicle. In an effort to move away from the dependence on batteries there has been a push towards the implementation of in-motion charging of electric vehicles using wireless power transfer. In order to establish this technology as a feasible option it is necessary to understand the economics, environmental impact, and infrastructure requirements associated with deployment. The presented research understands these

factors through the use of dynamic vehicle models integrated with geographically diverse real-world drive cycles. Optimization results show that the vehicle characteristics of a wireless power transfer electric vehicle fleet will consist of a 25 mile range electric vehicle using 2C stationary charging and 50 kW charging on high speed primary and secondary roadways, representing a roadway infrastructure cost of \$1.45 trillion. When used in conjunction, optimized vehicle and roadway architectures satisfy 97.7% or 17,223 24-hour drive cycles, a 22.4% increase from when no in-motion charging is used. Economic results show a societal return on investment of 36.7 years assuming a roadway retrofitting cost of \$2.5 million lane<sup>-1</sup> mile<sup>-1</sup> and an infrastructure deployment of 13,788 miles<sup>-1</sup> year<sup>-1</sup>. Expanding models to evaluate the environmental impact shows that total emissions from light duty vehicles and Class 8 trucks will be reduced by 29.3 trillion kg CO<sub>2</sub>-eq. (30.6%) when compared to a business as usual scenario during the first 50 years of technology deployment. Overall, results show that in-motion charging using wireless power transfer presents both economic and environmental benefits when compared to conventional internal combustion transportation and a long range electric vehicle fleet.

(108 pages)

## PUBLIC ABSTRACT

Optimization of Roadway Electrification Integrating Wireless Power Transfer: Techno-  
Economic Assessment and Lifecycle Analysis

Braden J. Limb

Electric vehicles are the main technology currently being pursued to reduce dependence on fossil fuels in the transportation sector. These vehicles provide both reduced greenhouse gas emissions and decreased operating costs when compared to conventional internal combustion vehicles, while providing the flexibility to use both renewable and fossil energy. However, these vehicles have seen limited consumer adoption due to their large purchase prices and limited driving range. Both purchase price and driving range are related to the large onboard battery systems required for electric vehicle travel.

One solution to decrease dependence on large battery systems has focused on charging vehicles in-motion using wireless power transfer. In-motion charging of electric vehicles would allow for longer range travel with smaller onboard battery systems which would lead to cheaper vehicles and, in turn, greater consumer acceptance. Wireless power transfer is commonly used for small electronics (i.e. cell phones), but has seen limited use on large scale projects. Therefore, limited work has been done to understand the feasibility of in-motion charging of electric vehicles using wireless power transfer.

The goal of this thesis is to better understand the economic feasibility, environmental benefit, and infrastructure requirements of a wirelessly charged electric vehicle fleet for transportation in the United States.

## ACKNOWLEDGMENTS

First and foremost I would like to thank my major professor, Dr. Jason Quinn, for not only providing me with this research opportunity, but for also being an invaluable mentor and friend in all aspects of research and life over the past two years. I would also like to thank Jason's wife, Danna, and their children for graciously allowing Jason to spend countless hours reviewing my work when he could've been spending time with the family. Additionally, I would like to thank my committee members, Drs. Regan Zane and Robert Spall, and Dr. Thomas Bradley for their support and assistance throughout both my education and research endeavors. Thanks to all of my research colleagues (Lucy Quinn, Benjamin Vogel, Alan Edland, Hailey Summers, Michael Jones, Jay Barlow, Ahmed Azad, Derek Hess, Eric Torres, Brian McNeill, Chad De Mill, and the semi-imaginary Colin Schlicher) for sitting through hours of presentations, providing constructive criticism of my research, partaking in stress relieving Frisbee breaks, being great friends, and striving to make our entire research group better. Also, many thanks to Karen Zobell, Sally Yang, and Chris Spall for taking care of all of the paperwork associated with my research travel, tuition awards, and graduation requirements. I'd be vacuous if I didn't thank my family (Mary, Breshae, Jared, and Donna), friends (Sam Blatchford, McKenna Sumrak, Tyler Murphy, Katrina Christenson, Heidi Hallmark, Emily Esplin, Andrea Halling, Chris Andrew, Chris Patty, Kylie Elwood, Justin Miller, Karson Kalian, Jessica Morrill, Sam Burrows, Kayli Kunzler, and countless others), and everyone else I have interacted with during my time at Utah State. Each one of these people have played an important part in turning me into the person I am today and have provided the support necessary for me to chase my dreams. I'd also like to give a special thank you to Kelli Morrill who has ensured I maintain a healthy work/life balance throughout my graduate career and provided more support, companionship, and inspiration than I could've asked for. Last but not least, I would like to thank Dr. Andrew Sweeney, the Governor's Office of Energy Development in the State of Utah, and USTAR for providing funding for this project and selecting me as Governor's Energy Scholar. None of this research would have been possible without their support.

Braden Jeffery Limb

## CONTENTS

	Page
ABSTRACT .....	iii
PUBLIC ABSTRACT .....	v
ACKNOWLEDGMENTS .....	vi
LIST OF TABLES .....	ix
LIST OF FIGURES .....	x
NOTATION .....	xi
ACRONYMS .....	xii
CHAPTER	
I. LITERATURE REVIEW AND PRELIMINARY RESEARCH .....	1
Introduction .....	1
Technology Overview .....	3
Preliminary Research .....	4
Methods .....	7
Techno-Economic Assessment and Life Cycle Analysis .....	10
Systems Optimization and Case Studies .....	14
Research Objectives .....	16
II. ECONOMIC FEASIBILITY OF TRANSPORTATION ELECTRIFICATION INTEGRATING WIRELESS POWER TRANSFER EVALUATED USING STANDARD DRIVE CYCLES .....	18
Abstract .....	18
Introduction .....	19
Methods .....	21
Results and Discussion .....	30
Conclusion .....	38
III. SYSTEMS OPTIMIZATION OF DYNAMIC CHARGING OF ELECTRIC VEHICLES INTEGRATING WIRELESS POWER TRANSFER: ECONOMIC VIABILITY AND ENVIRONMENTAL IMPACT USING REAL WORLD DRIVE CYCLES AND VARIABLE FLEET PENETRATION AND DEPLOYMENT .....	41
Abstract .....	41
Introduction .....	42



Methods .....	44
Results and Discussion .....	60
Conclusion .....	74
IV. CONCLUSIONS AND RECOMMENDED FUTURE RESEARCH .....	77
Conclusions.....	77
Recommended Future Research .....	78
REFERENCES .....	79
APPENDICES .....	88
A. Studies, Energy Mixes, and Emissions Associated with Each State .....	89
CURRICULUM VITAE .....	92

## LIST OF TABLES

Table		Page
1	Vehicle modeling specifications .....	25
2	Energy consumption results for ICE vehicle and WPT EV architectures presented in Wh mi <sup>-1</sup> for light duty vehicles and Class 8 trucks.....	31
3	Baseline usage costs per kWh for vehicle and roadway types based on a 25% owner's energy savings .....	37
4	Optimization results for sedan and coupe drive cycles.....	61
5	Percent of drive cycles and vehicles satisfied when in-motion charging is and is not used including a comparison to an all-electric EV (300 mile range).....	63
6	Percent of Monte Carlo vehicles satisfied when in-motion charging is and is not used including a comparison to an all-electric EV (300 mile range).....	65

LIST OF FIGURES

Figure		Page
1	System concept for integration of WPT into an electrified transportation system .....	3
2	Societal payback as a function of market penetration .....	5
3	Comparison of environmental impact (criteria pollutants and carbon dioxide emissions) of a traditional vehicle compared to a WPT EV .....	6
4	Block diagram depicting an inductive WPT system .....	9
5	Light duty vehicle cost breakdown .....	34
6	Societal payback time of WPT infrastructure as a function of fleet penetration .....	35
7	Societal payback time as a function of vehicle owner operational savings at a baseline 10% WPT EV fleet penetration. ....	37
8	Map of assumed electrified roadway deployment at 13,788 miles per year .....	58
9	Historical technology penetration rates .....	59
10	Vehicle level costs for each vehicle class and architecture type. ....	67
11	Societal cash flow curves for varying roadway miles electrified each year .....	69
12	Cost to satisfaction curve for real world drive cycles and vehicles. ....	71
13	Environmental impact comparison of light duty ICE vehicle and WPT EV for U.S. ....	72
14	Varying emissions from light duty vehicles and Class 8 trucks as the in-motion WPT technology is adopted. ....	73
15	Transportation study associated with each state in the United States .....	89
16	Electricity costs associated with each state in the United States .....	90
17	Electricity emissions associated with each state in the United States .....	90
18	Gasoline costs associated with each state in the United States .....	91

## NOTATION

$A$	Frontal Area
$Cd$	Drag Coefficient
$Cr$	Rolling Resistance Coefficient
$D$	Drag Force
$G$	Gravitational Force
$m$	Vehicle Mass
$R$	Rolling Resistance
$V$	Vehicle Velocity
$\beta$	Roadway Grade
$\rho$	Air Density

## ACRONYMS

ANL	Argonne National Laboratory
CO	Carbon Monoxide
DCFRROR	Discounted Cost Flow Rate of Return
DOE	Department of Energy
ESS	Energy Storage System
EV	Electric Vehicle
FCV	Fuel Cell Vehicle
GIS	Geographic Information Systems
GPS	Global Positioning System
GWP	Global Warming Potential
HEV	Hybrid Electric Vehicle
HWFET	Highway Fuel Economy Test – Standard Drive Cycle
IRS	Internal Revenue Service
ICE	Internal Combustion Engine
LCA	Life Cycle Assessment
LCI	Life Cycle Inventory
MACRS	Modified Accelerated Cost Recovery System
MG	Motor/Generator
MPG	Miles per Gallon
MPH	Miles per Hour
NO <sub>x</sub>	Nitrogen Oxide
NREL	National Renewable Energy Laboratory

PHEV	Plug-in Hybrid Vehicle
PM10	Particulate Matter 10 microns
PM2.5	Particulate Matter 2.5 microns
ROI	Return on Investment
rpm	Revolutions per Minute
SELECT	Sustainable Electrified Transportation Center
SOC	State of Charge
SO <sub>x</sub>	Sulfur Oxide
TEA	Techno-Economic Analysis
Tx	Transmission
UDDS	Urban Dynamometer Driving Schedule – Standard Drive Cycle
VOC	Volatile Organic Compounds
WPT	Wireless Power Transfer

# CHAPTER 1

## LITERATURE REVIEW AND PRELIMINARY RESEARCH

### Introduction

Transportation is one of the primary sources of fossil fuel use in the United States each year accounting for 27 quadrillion Btu's of energy. This equates to 27.7% of the total energy and 78% of the petroleum used by the United States [1]. Of this petroleum, 33% is imported from foreign countries [2]. As there is an increased initiative to become energy independent, the need for alternative vehicle technologies has become more prevalent. Electric vehicles (EVs) are one of the primary alternatives currently being pursued. Acceptability of these vehicles is closely related to the range and costs associated with them. The main component that contributes to range and cost is the battery. Increase in battery size results in more range, but also increases the cost and weight of the vehicle [3]. In an effort to move away from the dependence on batteries there has been a push towards the implementation of in-motion wireless power transfer (WPT) to EVs. In order to establish this technology as a feasible option it is necessary to first create system models of the WPT/EV system.

System models are very common in the field of alternative vehicles (hybrid, plug-in hybrid, fuel cell, and battery electric vehicles). These models are created for a variety of reasons including: vehicle performance, prediction, safety, structural integrity, component testing and validation, and emissions [4]. Once models are created they can then be used as leverage for optimization of the system [5, 6], techno-economic analyses

[7], and forecasting of consumer acceptability and market penetration rates [8, 9].

Systems models are also used throughout the field of WPT and have been applied to optimize charging systems of wide variety from visual prosthesis [10] to robots [11]. That said, systems models of WPT to EVs have not been developed and very minimal techno-economic analysis and life cycle assessments have been completed on this technology. It is essential that systems models of this technology are created such that techno-economic assessments, life cycle analyses, systems optimization, and prediction of market penetration rates can be evaluated before the technology implemented on a larger scale.

The proposed research includes the creation of dynamic vehicle models of the WPT/EV system. These models will be leveraged to perform techno-economic analysis, life cycle assessments, and optimization for these systems. They will also be used as the foundation for critically evaluating a variety of possible transportation systems (personal transportation, public transportation, and closed campus transportation) for implementation of the WPT technology. The models will also enable a direct comparison to existing technologies (i.e. traditional internal combustion vehicles). Optimization of vehicle components will be included to analyze unique vehicle architectures for different applications as well as providing trade-offs in architecture and performance will also be assessed. Models will be validated by research being performed at Utah State University to ensure foundational model accuracy. Results from the modeling work will be used to better understand the research and development needs for the advancement of in-motion wireless power transfer for transportation and support efforts focused in these areas.



### Technology Overview

The proposed research is focused on the critical evaluation of WPT integrated into transportation systems. Integration of WPT in roadways and vehicles represents a promising alternative to traditional internal combustion engine (ICE) transportation systems and other advanced vehicle concepts such as hybrid electric vehicles (HEVs), plug-in hybrid electric vehicles (PHEVs), and electric vehicles (EVs). A schematic illustration of the technology is presented in Figure 1.

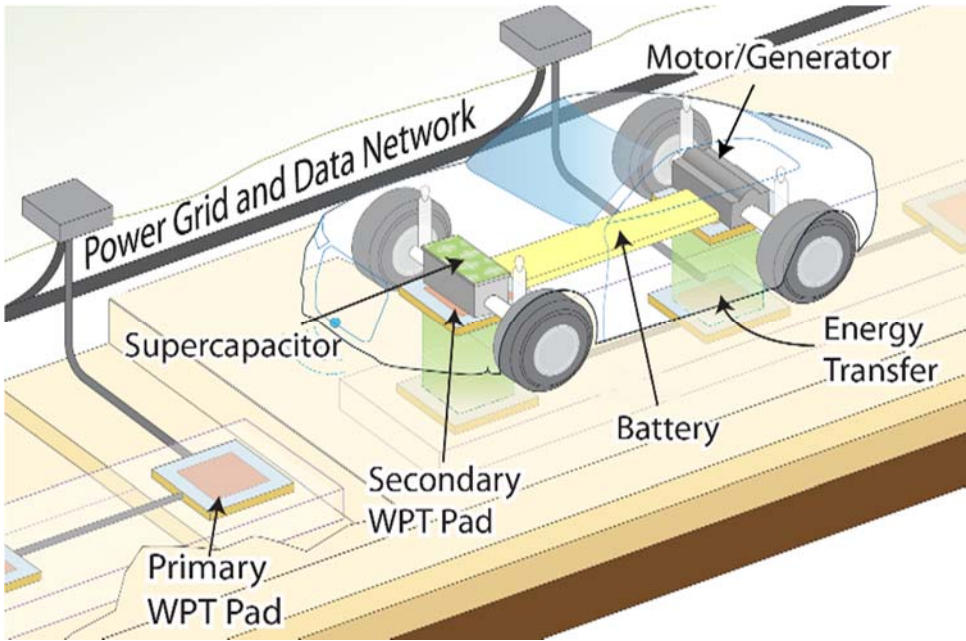

Figure 1. System concept for integration of WPT into an electrified transportation system.

WPT would enable the transformation of vehicle architecture and address many of the current limitations associated with the electrification of vehicles such as restricted

range and vehicle weight. Current research efforts are focused on development of the technology, however the requirements of the technology and the architecture of a system have not been investigated. The proposed work is focused on the development of dynamic models that can be leveraged to understand the techno-economic feasibility, technology requirements, and optimization of the roadway and vehicle architecture specific to transportation systems.

### Preliminary Research

In order to determine if research related to the WPT/EV technology was worth pursuing, Dr. Jason Quinn completed a preliminary analysis. The results are as follows.

#### **Societal Payback**

The techno-economic results for the societal payback of WPT to EVs are presented in Figure 2 as a function of penetration rate. Results for the electrification of two roadway systems are presented, interstate and interstate and urban systems. The error bars illustrate the impact of gasoline fuel price on the return on investment.

The societal payback at a 20% fleet penetration for the interstate and urban scenario for the baseline case is a promising 2.6 years. Fuel price is shown to dramatically impact the payback at small penetration rates with the impact decreasing as penetration rate increases. The results of the analysis are driven by the low cost of delivering energy to the wheels of an EV compared to a traditional ICE vehicle. This is primarily driven by the high efficiency of electrical production, delivery, and use compared to that of an ICE based architecture. It is acknowledged that rollout of an

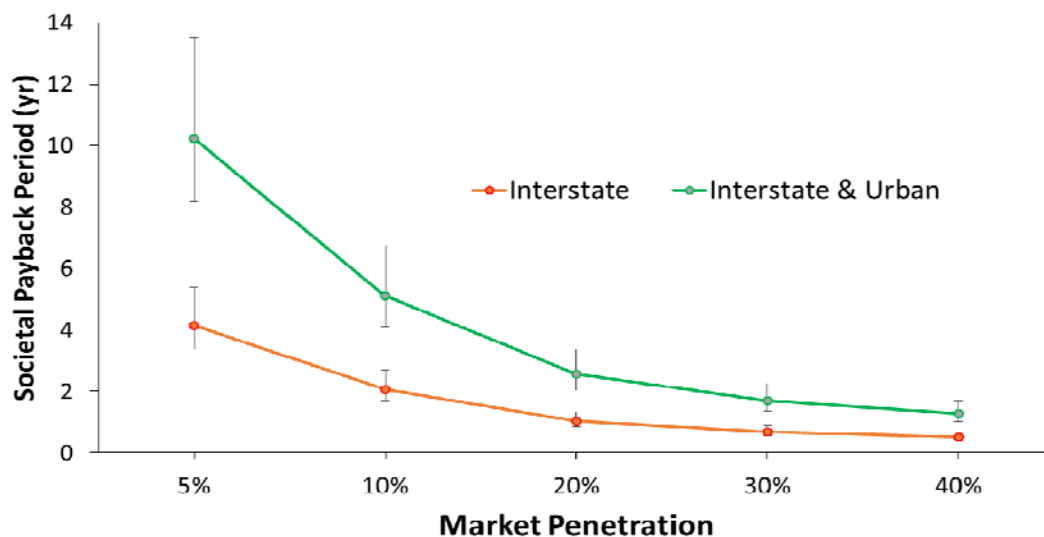

Figure 2. Societal payback as a function of market penetration. Two electrification scenarios are presented, 1) interstate roadway system (orange) and 2) interstate and urban roadways (green). Error bars represent sensitivity to fuel prices.

electrical system represents a major challenge; however the economics of the WPT system are promising. It is expected that small scale systems such as public transportation systems or closed campus transportation would be ideal for demonstration facilities.

### Environmental Impact

The environmental impact is separated into two metrics, global warming potential ( $\text{g-CO}_2\text{-eq mi}^{-1}$ ) and criteria pollutants (VOC, CO, NO<sub>x</sub>, PM<sub>10</sub>, PM<sub>2.5</sub>, and SO<sub>x</sub>). Results for the light duty vehicle are presented in Figure 3. The WPT EV has a 49% CO<sub>2</sub> savings compared to a traditional ICE vehicle. Further, the emissions associated with the WPT EV are centralized and not emitted at the point of consumption. In terms of criteria pollutants, SO<sub>x</sub> is the only one that increases. This is primarily driven by the amount of SO<sub>x</sub> produced in coal based power which represents 39% of the power for the WPT EV. Significant reductions are seen in the other criteria pollutants, specifically a 99%

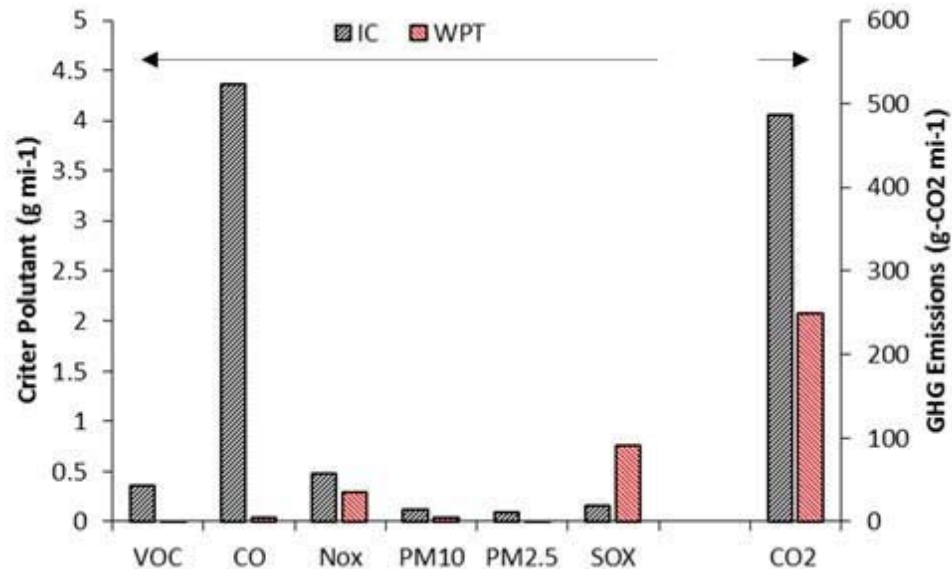

Figure 3. Comparison of environmental impact (criteria pollutants and carbon dioxide emissions) of a traditional vehicle compared to a WPT EV.

reduction in VOC and CO, a 75% reduction in PM<sub>2.5</sub> and PM<sub>10</sub>, and a 40% reduction in NO<sub>x</sub>. Combining these results with the total number of miles driven by light duty vehicles and trucks in the US, the total amount of CO<sub>2</sub> emissions decreases by 10.1% (134 million tons per year savings, greater than the DOE VT MYPP 2030 goal) assuming a 20% fleet penetration rate.

Based on these preliminary modeling results, electrification of transportation using WPT has the potential to dramatically improve the economic and environmental costs of personal and commercial transportation in the U.S. Due to these promising results, a more in-depth analysis of this technology is desired and is the basis of the proposed research.

## Methods

### **Vehicle and WPT Modeling**

A primary task of the proposed research is to develop and integrate dynamic models of the WPT/EV system so as to be able to describe the dynamics associated with the technology. The systems of interest will include the dynamics of the vehicle state of charge, the dynamics of the vehicle energy management system, and the efficiency and power capability of the WPT system. All modeling will be performed according to automotive engineering best practices in the MATLAB™ Simulation™ Stateflow™ and SimScape™ modeling languages. The objective of the modeling effort will be to describe the dynamics of vehicle energy management, the vehicle energy consumption, and the effect of vehicle component sizing as a function of design variables that include drive cycle, WPT unit spacing, vehicle class, and more.

#### *Dynamic Vehicle Modeling*

The baseline vehicle simulation is a dynamic vehicle fuel economy and energy consumption simulation. The *MATLAB/Simulink*™ simulation language is used to develop the baseline simulation models, and to solve for the performance of the vehicles. *Simulink* is a physical-system modeling tool that allows for system transparency, modification and repeatability. The primary components to be modeled for this study include an internal combustion engine (ICE), electric motors/generators (MG), lithium-ion battery energy storage system (ESS), vehicle glider, transmission (Tx), final drive gear, and controller. For an example of the methods that will be used, we can describe the modeling of the EV. Modeling of the electric motor/generator uses a motor model that is

a function of torque, speed, input voltage, and temperature. Scalable torque curves and torque-speed efficiency maps are based on the MG from the 2013 Nissan Leaf as measured at the ANL Downloadable Dynamometer Database. Efficiency in the MG is used to relate output power (torque and angular velocity) to the required electrical input power (current and voltage). The lithium-ion modeled ESS is a quasi-static, non-thermal system. Battery state of charge (SOC) is determined based on nameplate capacity and integrated energy use from the electrical system. Output voltage is determined using SOC resolved internal resistance (both charge resistance and discharge resistance) and open circuit voltage calculations. Scaling of the battery system is performed through modification of a scaling factor for the internal resistance and total capacity. Through the scaling of resistance and capacity, total battery energy and power can be defined. To validate the vehicle models, we will compare the performance of the EV model against the data presented from the Advanced Powertrain Research Facility's Downloadable Dynamometer Database.

#### *Wireless Power Transfer Subsystem Modeling*

The modeling of WPT represents a core component to the proposed research. WPT modeling will focus on performance of an inductive system and will not be done at such a level as to perform research development of coil systems, but rather at a level that sufficiently captures the current and expected performance of the technology as a function of design parameters. A core set of variables will be used to define the function of the WPT system with two WPT systems modeled, a transmitter and a receiver. An illustration of the WPT system is presented in Figure 4.

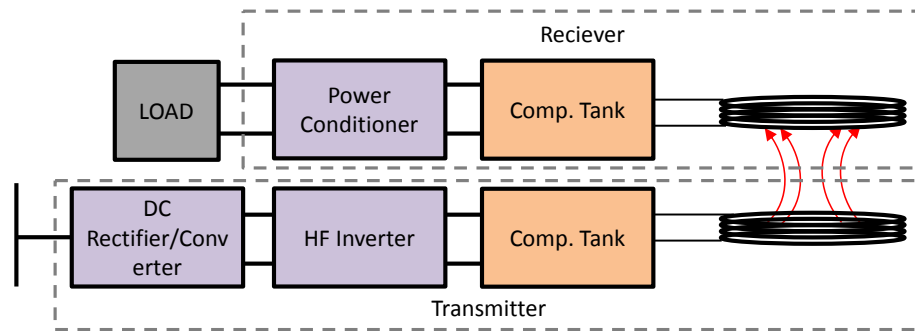

Figure 4. Block diagram depicting an inductive WPT system

Modeling of the WPT system will include understanding the transfer power, transfer efficiency and power transfer density with details on how these quantities will be represented as a function of pad design presented below.

The WPT effort is focused on modeling the current and expected near-term performance of the technology. Flexibility in pad performance based on transfer power, efficiency and density can be altered through foundational inputs to the model and will include the impact of alignment.

#### *Integration of Vehicle and WPT Models*

Coupling of WPT models with dynamic vehicle modeling will be performed. The objective of this task will be to develop a MATLAB based, parametric model of the WPT system that can be implemented into a dynamic vehicle model. USU's previous work on vehicle WPT has concentrated on the detailed description, rigorous optimization, and electro-magnetic design optimization of the WPT components. In this model, these models will be condensed into ordinary differential equation models of the WPT system. The flexibility of the dynamic vehicle modeling will allow the seamless integration of the

WPT models. As a part of the integration task alternative energy storage systems will be modeled for on-board energy storage. For an example of the type of system-level interaction that will be explored, it is anticipated that the battery technology used in EVs will not be able to accommodate large (>100kW) power charging events that are expected with WPT. Alternative energy storage architectures such as super-capacitor/battery hybrids, or HEV-type lithium-ion batteries could be required to enable the WPT system.

The integration of WPT with vehicle modeling will allow for an initial comparison of WPT enabled vehicles with traditional vehicles such as EVs, PHEVs, HEVs, and ICE vehicles. Analysis will focus on evaluating architectures of the various modeled vehicle systems through standard drive cycles, US06, FTP-75, HWFET, etc. Design optimization will be used to understand optimal vehicle architecture for the various vehicle configurations.

#### Techno-Economic Assessment and Life Cycle Analysis

When the dynamic vehicle and WPT models are completed, a detailed model of the economic and environmental costs and benefits of the WPT EV relative to conventional ICE vehicles and conventional EVs will be generated. This task will involve the research tools of Techno-Economic Analysis (TEA), life cycle assessment (LCA), transportation statistics, and policy compliance. By quantifying the economic and environmental comparison between WPT EVs and more conventional vehicle technologies, we can seek to understand the relative consumer acceptability, societal



costs and benefits, and the commercial viability of the technology.

### **Techno-Economic Assessment**

The architecture of the economic modeling will be structured to integrate with the vehicle system model. The baseline economic work will be focused on two aspects 1) total cost of ownership for the vehicle and 2) infrastructure costs associated with supporting WPT. The economic modeling of the vehicle will include all costs associated with owning and operation of the vehicle. The economic modeling of the infrastructure will be based on a *Discounted Cost Flow Rate of Return* (DCFROR) analysis. The DCFROR will be used to outline the economics for each year of the system. This will include breakdowns of income, costs, depreciation, and taxes paid each year. This will provide selling costs of electricity in order to achieve a user defined return on investment (ROI).

The vehicle system model will serve as the foundation of the TEA. Vehicle architecture and energy requirements from the vehicle model will serve as the primary inputs for determining the total cost of vehicle ownership. Road energy requirements will be used as inputs for defining the roadway infrastructure costs. The architecture of the modeling work will integrate the vehicle system model with economic assessment to facilitate an evaluation of the foundational modeling inputs based on the metric of economics. The foundational integration is a critical component for delivery on future milestones. Economic modeling inputs will include annualizing of capital costs, financing of the infrastructure through a multidimensional rate structure to allow for investor and institutional investment and roadway life-time. Capital infrastructure costs will be

determined for the various components required for implementation of the WPT technology.

The DCFROR will be set up so that the user will be able to have a detailed yearly breakdown of the overall economics. This will include capital investment, loan repayment separated into principle and interest, operation costs, annual depreciation, net revenue, taxable income and annual cash flows. Depreciation will be calculated using the Modified Accelerated Cost Recovery System (MACRS) which offers the shortest recovery period and largest tax deductions as outlined by the IRS. The analysis will begin with construction and accounts for the time period where the roadway is being upgraded meaning only interest on the capital investment loans is being paid as there will be no income.

### **Life Cycle Analysis**

LCA will be used to understand the environmental impacts of the integration of WPT into a transportation system. The vehicle system model will serve as the foundation for this work. The environmental impact of the vehicle performance will be evaluated based on a global warming potential (GWP). The system boundary for the assessment will be consistent with traditional vehicle systems to facilitate a direct comparison of WPT technology to other technologies.

The LCA work will focus on the environmental impacts of 1) vehicle operation, 2) infrastructure of the roadway and 3) vehicle manufacturing. To evaluate the environmental impact of vehicle operation, a LCA module will be constructed that is foundationally integrated with the vehicle system model. Vehicle energy consumption

from the vehicle system model will serve as the primary inputs to this aspect of the LCA work. For the evaluation of the roadway infrastructure and vehicle manufacturing, the vehicle architecture and roadway requirements will be integrated with life cycle inventory data (LCI) collected from the ANL GREET model, NREL LCI database, and literature. The work will include all upstream emissions associated with material production and energy consumption for the various components of the vehicle. For all the environmental assessment work, the GWP will be determined through a carbon dioxide equivalency ( $\text{CO}_2\text{-eq}$ ) which includes  $\text{CO}_2$ , methane, and dinitrogen oxide emissions. The IPCC 100 year impact factors of 25 and 298 will be used for methane and dinitrogen oxides respectively.

Two additional LCA capacities will be integrated into the foundational modeling effort, 1) criteria pollutants and 2) energy source sensitivity. *Criteria pollutants*: The LCI database will be expanded to include criteria pollutants ( $\text{CO}$ ,  $\text{PM}_{10}$ ,  $\text{PM}_{2.5}$ ,  $\text{NO}_x$ ,  $\text{O}_3$ , and  $\text{SO}_x$ ). The methods applied to the calculation of  $\text{CO}_2$  release for example will be applied to criteria pollutants. Upstream emissions associated with the production of materials and energy will be included. *Energy source sensitivity*: Current and future data about electrical energy source and corresponding emission will be integrated into the primary inputs of the LCA module. This will enable geographically specific modeling of the roadway implementation and use.

## Systems Optimization and Case Studies

The goal of this section is to seek to understand the commercial and practical viability of the WPT electric vehicle concept. This task will involve gathering transportation datasets that can characterize the vehicle and WPT system requirements of various transportation use cases (bus service, personal transportation, fleet service, etc.). These datasets will be used to derive optimal system characteristics for the WPT system and vehicle, and to evaluate the commercial viability of the WPT concept and vehicles.

### **Optimization**

The combined modeling package will be used to understand vehicle architecture and roadway requirements to meet current consumer driving patterns. Drive cycle data collected by the National Renewable Energy Laboratory (NREL) through the Secure Transportation Data Center and the data from the National Household Travel Survey database will be used with the vehicle system model to understand the requirements of the WPT system. Various charging schemes will be evaluated (home only, home and work, etc.). Modeling of traditional systems will be done in parallel such that a direct comparison of WPT system can be made. Results from the work will include a statistical assessment of required architecture to satisfy various percentages of the tested drive cycles. The economics and environmental impact associated with the various architectures will be reported.

### **Case Studies**

It is well understood the rollout of a WPT system for the electrification of the national transportation represents a significant hurdle. It is expected the technology will

be developed and implemented initially on small case studies such as city public transportation and closed campuses. These studies will integrate data from the Utah State University bus route to perform a systems optimization of the bus architecture and roadway requirements. The work will include the evaluation of two charging platforms: 1) stationary and 2) in-motion. Bus route information will be used as inputs to the modeling efforts to determine optimum bus and roadway architecture. The resulting systems will be evaluated for economic feasibility and environmental impact.

The economic viability and environmental impact of implementing WPT at a national scale will also be evaluated. This will include the evaluation of upgrading interstate and urban roadways with WPT technology. Rural roads represent the majority of the number of miles that are paved in the US, however only 23.6% of the miles (698 billion miles) driven in the US are performed on this classification of roadway with 76.4% performed on urban (1.5 trillion miles) and interstate (732 billion miles) roadways. Based on feasibility of rollout this case study will be limited to implementation on the interstate and urban roadways. Dynamic simulations will be performed through the integration of drive cycle patterns with total miles driven on the various classifications of roadways. A sensitivity to drive cycle will be performed to minimize the error of the simulation. The simulated case study will explore various WPT vehicle and roadway architectures.

## Research Objectives

Current status of tasks associated with this technology include: 1) systems architectures for dynamic WPT have not been defined, 2) a vehicle level understanding of the effects of WPT on battery sizing, vehicle performance, and vehicle components has not been developed, and 3) the scalability of the technology has not been assessed in terms of environmental and economic costs. WPT has a variety of advantages that are synergistic with current vehicle research emphasis including reduced energy consumption, decreased vehicle weight, decreases in vehicle ownership costs, and improvements in environmental impact.

The expected outcomes from the project include the development and use of a tool set that can enable industry to understand the potential impact of WPT on transportation. The tool set will include the integration of dynamic vehicle models with WPT modeling to evaluate and optimize vehicle architecture and roadway infrastructure. Evaluation of the technology will be performed on the metrics of economic feasibility and environmental impact. A direct comparison to existing technologies will be made. Results from this work will be demonstrated as a part of the Center for Sustainable Electrified Transportation (SELECT) at Utah State University. Key questions to be answered are:

- What is the large scale economic impact of a WPT EV fleet in the United States?
- What is the large scale environmental impact of a WPT EV fleet in the United States?

- What does the vehicle architecture and roadway infrastructure need to look like in order to satisfy real world consumers?
- What does the large scale technology deployment look like for the United States?

CHAPTER 2  
ECONOMIC FEASIBILITY OF TRANSPORTATION ELECTRIFICATION  
INTEGRATING WIRELESS POWER TRANSFER EVALUATED USING  
STANDARD DRIVE CYCLES

Abstract

Integration of wireless power transfer (WPT) systems into roadways and vehicles represents a promising alternative to traditional internal combustion engine (ICE) transportation as well as other electrified transportation technologies. In this study, the economic feasibility of WPT applied to the U.S. transportation system is evaluated using dynamic vehicle and economic modeling. Results show a promising societal level payback time (defined as the time required for total ownership savings of WPT vehicles compared to traditional ICE vehicles to equal roadway infrastructure costs) of 5.9 years based on a 10% WPT electric vehicle (EV) fleet penetration. On a vehicle level, total lifetime savings of WPT EVs compared to traditional ICE vehicles is greater than the purchase price of WPT EVs. The modeled system has the potential to impact 76% of all traffic in the U.S., effects 42% of all paved roadways, and reduces annual petroleum consumption by 217 million barrels. Discussion focuses on results from model sensitivity to roadway coverage, payback time as a function of WPT EV fleet penetration, and an evaluation of WPT roadway infrastructure payback time while including consumer centric reimbursement.



## Introduction

Transportation is a principal consumer of fossil fuels in the United States, accounting for 27.7% of the total energy consumed and 78% of the petroleum used annually [2]. Increasing pressure to reduce dependence on foreign fossil energy and minimize environmental impact motivates the development of alternatively-fueled transportation systems, including electrified personal and commercial transportation. A variety of electrified transportation technologies are being investigated including electric vehicles (EVs), plug-in hybrid electric vehicles (PHEVs), and hybrid electric vehicles (HEVs). The consumer acceptability and market penetration of these vehicles has been limited due to their restricted range, long recharging times, and high total purchase price compared to traditional internal combustion engine (ICE) vehicles [12]. The conventional solution to low EV range has been the development of vehicles with large battery capacity, despite the associated increase in vehicle cost and weight [3]. In an effort to move away from the dependence on large battery systems, there has been a growing interest in the implementation of in-motion wireless power transfer (WPT) with EVs. In-motion WPT promises to enable long-range personal travel with EVs. However, the economic and technical feasibility of a WPT EV fleet has not been explored.

Computational dynamic vehicle models have been used to understand the economic and energetic impact of alternative transportation vehicles including EVs, PHEVs, and HEVs with the investigation of a variety of architectures (fuel cell, series or parallel hybrid, etc.). Previous modeling efforts have focused on the evaluation and design of vehicle performance, safety, structural integrity, component testing and

validation, architecture optimization, techno-economics, environmental impact, and forecasting of consumer acceptability and market penetration rates [4-8, 13].

Computational models have been developed and applied to WPT research and development for the optimization of charging systems used in various applications ranging from visual prosthesis [10] to robotics [11]. Minimal modeling and assessment work has been done to understand the application of WPT to transportation systems [14]. By developing integrated vehicle and WPT models, this study seeks to evaluate the techno-economic feasibility of WPT in transportation applications and perform system-level analysis and optimization of vehicle architecture and roadway charging infrastructure.

This work leverages dynamic vehicle models that can evaluate the economic feasibility of in-motion WPT applied to the U.S. transportation system. Vehicle modeling includes all components required for the deployment of a WPT system and allows for a direct comparison to ICE vehicle. The work facilitates an evaluation of required WPT roadway infrastructure, energy use, and technology deployment on interstate and urban roadways for light duty vehicles and Class 8 trucks in the U.S. Results from the roadway optimization and vehicle modeling are integrated with economic models to understand the commercial feasibility of in-motion WPT charging for mass transportation in the U.S. Discussion focuses on the sensitivity of results to WPT EV fleet penetration and a potential infrastructure reimbursement plan for recovering upfront roadway installation costs and sustaining the expansion of infrastructure with increased penetration.

## Methods

In-motion WPT technology requires the development of both roadway infrastructure and vehicle components. A conceptual schematic of the technology is illustrated in Figure 1. In this concept of in-motion WPT, the vehicle is an EV with on-board energy storage that allows for limited distance travel between in-motion charge events. When the secondary WPT pad attached to the vehicle comes into alignment with the primary pad, electric power is transferred to the vehicle through the WPT system with the electric grid being the source of the energy to drive the vehicle and excess power transferred to onboard storage.

A suite of vehicle models were developed to quantify energy consumption of WPT EVs and roadway infrastructure requirements. Detailed descriptions of the vehicle, roadway, economic modeling, and model validation systems are presented in the following sections.

### **Vehicle Modeling**

Vehicle modeling included the development of light duty vehicle and Class 8 truck models with either a WPT EV or ICE architecture. Models were developed using MATLAB/Simulink software and contain all vehicle components required for the various architectures. Details of each vehicle component and associated function are described in the following sections.

#### *Vehicle Dynamics and Control*

The vehicle dynamics subsystem contains the main forces acting on the vehicle: gravitational forces, rolling resistance, and drag force. These forces are calculated using

vehicle mass, roadway grade, tire size, rolling resistance coefficient, frontal area, drag coefficient, and air density. This subsystem also houses the braking torque actuator, which is activated within the torque controller. Both brake torque and vehicle forces are added to the mechanical driveshaft as negative torques that slow down the vehicle. The vehicle subsystem also contains constant inertias for the driveshaft and half shafts which are used to accurately calculate the speed of the driveshaft.

The control subsystem is broken down into two main components: the driver model and the powertrain controller model. A similar control architecture is used for both WPT EV and ICE vehicles. The driver model compares the desired drive cycle velocity to the modeled vehicle's velocity with the result used to either increase or decrease torque. If the incoming torque request is positive, the request is routed to the motor/generator in the WPT EV model and to the engine in ICE model. If the incoming torque request is negative, energy is split 50/50 between the brakes and motor/generator in the WPT EV model while 100% of the request is routed to the brakes in the ICE model. The negative torque request is split for the EV architecture to incorporate regenerative braking.

#### *WPT EV Powertrain Model*

The WPT EV Powertrain model includes a motor/generator connected to a fixed gear ratio transmission, a battery for energy storage, and a WPT system for receiving power. The motor/generator subsystem performs similar duties as the engine in the ICE model. The motor/generator torque request is sent from the torque controller and used to calculate the torque output from the motor. The motor/generator subsystem uses the

known torque versus rpm curve from experimental motor data such that the motor can only output torque to the maximum motor output. Once the torque is calculated, a torque actuator is used to send the torque to the vehicle's driveshaft. Based on the motor's torque and rpm, the efficiency of the motor/generator is determined based on efficiency curves from experimental data. By using the efficiency of the motor/generator, the required electric energy from the on-board energy storage is determined. Experimental motor data from the Nissan Leaf was used for all EVs and was scaled based on the maximum torque and power requirements of each vehicle system modeled.

The battery subsystem is used for long term energy storage and calculates battery current and state of charge (SOC). The battery current demand is derived from three components: motor/generator, incoming WPT, and accessory load. Battery characteristics, current, SOC and battery temperature are used to calculate the battery's internal resistance and open circuit voltage. Both internal resistance and open circuit voltage are determined through lookup tables based on experimental battery data. The actual battery voltage is then calculated by subtracting the voltage associated with the internal resistance from the open circuit voltage. The battery current and actual voltage are used to calculate the output energy associated with the battery such that the SOC can be determined at each time step. The characteristics of the battery subsystem are derived from, and validated against, the performance of the A123 20Ah 7x15s3p modules.

The WPT subsystem is used to transfer power to the vehicle from grid connected WPT pads embedded in the roadway. A controller is built into the WPT subsystem such that the user can specify when power is wirelessly transferred to the vehicle based on roadway distance or vehicle speed. The power transferred to the vehicle is sent to a

supercapacitor system, which is required to absorb the large transient energy pulses without negatively impacting battery life [15-17]. The supercapacitor model limits the incoming power based on the SOC of the supercapacitors. The model also limits the supercapacitor discharge current to levels consistent with 2C charging to ensure battery integrity. The control algorithm is set up such that the supercapacitor discharge fulfills the motor/generator and accessory load requirements first and sends the excess to the battery, further increasing the battery SOC.

#### *ICE Powertrain Model*

The ICE powertrain model includes an engine subsystem connected to a variable 5 gear transmission subsystem. The engine subsystem simulates the performance of the ICE with the engine torque request being sent from the torque controller. The engine subsystem compares the requested torque to the rpm based maximum engine torque and outputs the lower value to a torque actuator connected to the mechanical driveshaft. The engine subsystem also calculates the engine's fuel consumption based on the engine torque and engine speed. Both the maximum engine torque and fuel consumption are calculated using lookup tables which are based on experimental engine data. Outputs from this subsystem include engine torque, engine speed, and fuel consumption.

The transmission subsystem serves to change the gears of the ICE vehicle. This subsystem includes a built in controller that changes the gear ratio based on engine speed and torque request.

### *Vehicle Characteristics*

Two vehicle classes were modeled, light duty and Class 8 truck, with the objective of representing the breadth of vehicles currently on U.S. roadways. The most recent Bureau of Transportation Statistics report shows that the average light duty vehicle fuel economy is 23.4 miles per gallon (MPG) and 17.2 MPG for short and long wheel base vehicles, respectively [18]. To match this fuel economy, the light duty vehicle specifications are selected such that the average fuel economy of 24 MPG highway and 18 MPG city.

Using the specifications outlined in Table 1, both WPT EVs and ICE were modeled for light duty vehicles and Class 8 trucks. ICE specifications and fuel consumption were simulated using scaled experimental ICE data based on maximum engine torque and power. To ensure consistent performance between the two vehicle types, the electric motor was scaled until the WPT EV had the same 0–60 mph time as its ICE counterpart.

Table 1. Vehicle modeling specifications

Item	Light Duty	Class 8 Truck	Units
Vehicle Mass	2,072	20,000	kg
Tire Diameter	0.81	1.04	m
Frontal Area	2.23	10	m <sup>2</sup>
Maximum Engine Torque	303	2,000	N·m
Drag Coefficient	0.4	0.6	-
Driveline Efficiency	0.9	0.9	-
Rolling Coefficient	0.008	0.008	-

Other electric vehicle options such as PHEVs currently exist on the market, but represent only a small fraction of the U.S. vehicle fleet. PHEVs represent a class of vehicles in between traditional ICE vehicles and EVs. The U.S. passenger vehicle fleet penetration of PHEVs has only increased from 2.3% to 2.75% between 2007 and 2015, well below the predicted 10-15% by researchers [9, 19-21]. Even with the economic and environmental benefits of PHEVs, consumers are not adopting these vehicles because of the large upfront costs and long payback times compared to conventional ICE vehicles [19]. Due to the minimal market penetration seen for PHEVs, they have been excluded from this analysis. It is important to note, the technology modeled could be coupled with any electric vehicle architecture including PHEVs which could improve consumer acceptability of the technology.

#### *Vehicle Model Validation*

Vehicle model validation was performed in two steps. First, the vehicle modeling results were compared to experimental results available from vehicle testing. Second, the vehicle models were compared against a literature review of electrified transportation vehicle modeling results to ensure that the modeled energy consumption results are within the span of commonly referenced vehicle modeling studies.

The vehicle modeling results were validated at a detailed level by comparing model results to Argonne National Laboratory's (ANL) Downloadable Dynamometer Database for the EV and ICE vehicles over multiple drive cycles. EV models were validated by modeling the Nissan Leaf, Mitsubishi i-MiEV, and the Ford Focus Electric. The Toyota Corolla and conventional Ford Focus were used for validation of the ICE



vehicle model. EV validation results showed that vehicle models were within 0.53%, 1.64%, and 1.13% of expected energy consumption for the Leaf, i-MiEV, and Focus Electric respectively. ICE validation results showed vehicle models were within 1.08% and 3.92% of expected energy consumption for the Focus and Corolla respectively. These metrics are well within the accepted 5% accuracy for dynamic vehicle models.

Next, the modeled vehicle energy consumption was compared to other vehicle modeling results seen throughout literature. Twenty-three vehicles were reviewed from 4 articles [22-25] that compared energy consumption results for EVs and ICE vehicles over a variety of drive cycles. Results from this review showed the average energy consumption for EVs was 354 Wh mile<sup>-1</sup> with results ranging from 250 Wh mile<sup>-1</sup> to 550 Wh mile<sup>-1</sup>. Average energy consumption for ICE vehicles was 1,175 Wh mile<sup>-1</sup> with results ranging from 821 Wh mile<sup>-1</sup> to 1,871 Wh mile<sup>-1</sup>. All vehicles modeled for validation purposes fell within the observed ranges for each vehicle architecture. Due to the accuracy compared to both experimental data and other literature, it was determined that the accuracy of the dynamic vehicle models was sufficient for the analysis presented here.

Validated vehicle models were adapted to represent light duty vehicles and Class 8 trucks with an ICE architecture representative of current U.S. vehicles. A direct comparison of simulated and current energy consumption for the ICE light duty vehicles and Class 8 trucks was performed to provide model verification. The light duty ICE was within 1.3% (0.3 MPG) and 2.8% (0.5 MPG) for the Highway Fuel Economy Test (HWFET) and Urban Dynamometer Driving Schedule (UDDS), respectively. The ICE Class 8 truck was within 0.6% (0.04 MPG) and 4.5% (0.2 MPG) for HWFET and UDDS

drive cycles, respectively. Once verified, vehicle dimensions from the ICE models were used in the WPT EV models with the required energy management systems (WPT and supercapacitors) and drivetrain.

### **Roadway Infrastructure**

A total of 2.68 million miles of paved roadways exist in the U.S. and are broken down into three different classifications: interstate, urban and rural representing 1.7%, 39.9%, and 58.4% of the total paved miles, respectively [26]. Although rural roads represent the majority of paved miles in the U.S., only 23.6% (698 billion miles) of the annual distance driven in the U.S. are performed on this classification of roadway. The remaining 76.4% of miles driven are divided between urban (1.5 trillion miles) and interstate (732 billion miles) roadways [27]. Based on the feasibility of rollout of WPT infrastructure, this work excludes the upgrading of rural roads and only considers WPT on interstate and urban roadways.

Dynamic vehicle models were used to estimate the required WPT roadway coverage. The UDDS drive cycle was used with the dynamic vehicle models to evaluate urban roadways and the HWFET was used to evaluate the required coverage of interstate roadways. The WPT system was assumed to operate at an average power of 25 kW with a transfer efficiency of 83% from the grid to the supercapacitor system on board the WPT EV [28, 29]. The necessary WPT roadway coverage was based on the drive cycles presented in combination with the light duty vehicle model to maintain the SOC of the WPT EV throughout the drive cycle. It is assumed light duty vehicles will represent the characteristics of the nationwide WPT infrastructure, because the longer length of Class 8

trucks can support the 5 receiving pads necessary to offset the largest difference in energy consumption (4.8X) seen between the two vehicle classes.

### **Economic Modeling**

A techno-economic analysis was used to perform a societal level payback as a function of WPT EV fleet penetration. The societal level payback time was defined as the time it takes for the cost of the roadway infrastructure to be repaid through cost savings associated with the operation, maintenance, and purchase of the WPT EV compared to that of a traditional ICE vehicle. The baseline energy prices were set at \$2.64 gal<sup>-1</sup> for fuel and 12.7¢ kWh<sup>-1</sup> for electricity based on the United States Energy Information Administration's average costs for August 2015 [30]. The defined payback time is intended to understand the feasibility of the technology at a societal level and understand the potential impact of the technology.

The purchase price of the light duty vehicles and Class 8 trucks were set at \$33,453 and \$150,000, respectively [31]. Literature has shown that WPT EVs allow for a large reduction in battery size compared to traditional EVs resulting in lower purchase costs [28, 32]. To account for this, it was assumed that the WPT EV would be 30% cheaper than its ICE counterpart for both light duty and Class 8 trucks. Maintenance of ICE vehicles was set at 4% of the purchase price per year for both light duty vehicles and Class 8 trucks [33]. Due to the reduction in complexity of WPT EVs, the maintenance of these vehicles is assumed to be 2% of the purchase price per year [34]. Current EV OEMs have battery warranties lasting the life of the vehicle [35], therefore battery replacement costs were excluded from this analysis. It was assumed that the modeled

vehicles drive 11,346 miles year<sup>-1</sup> and 68,155 miles year<sup>-1</sup> for light duty vehicles and Class 8 trucks, respectively [36]. A 15 year lifetime was assumed for all vehicles [37].

The upgrade costs for integrating WPT infrastructure into the roadway is \$2.4 million lane<sup>-1</sup> mile<sup>-1</sup> [38, 39]. These costs include roadway retrofitting (50%), WPT electronics (40%), and electric grid power delivery infrastructure (10%). Urban roads are assumed to cost the same as interstate roads for upgrading. Modeling work includes retrofitting 2 lanes, one in each direction, for both the interstate and urban roadways. Roadway costs represent a dynamic variable with some roadways, such as intercity interstate systems, costing significantly more and other roadways costing less than the assumed value. The \$2.4 million lane<sup>-1</sup> mile<sup>-1</sup> is an average cost for the retrofitting, not expansion, of existing roadways as that is more costly. Maintenance of the system is expected to be minimal [39-41] as the coil systems is embedded in the roadway and the power systems have been demonstrated as robust [42]. Further, current pilot deployments of the technology have shown maintenance to be minimal [43]. As such, maintenance costs were assumed to be covered through existing roadway maintenance costs [44].

## Results and Discussion

Results and discussion are presented in three sections: 1) Vehicle level energy consumption and WPT roadway infrastructure optimization for interstate and urban roadways, 2) Vehicle and societal level economic results with an analysis of the payback time for the electrification of roadways using WPT, and 3) Societal payback time incorporating an infrastructure reimbursement plan which maintains operational savings

for system users.

### Energy Consumption and Roadway Infrastructure

Energy consumption results based on the validated vehicle models for both light duty vehicles and Class 8 trucks are shown in Table 2. Similar decreases in energy consumption are seen for each vehicle architecture by comparing a WPT EV to a traditional ICE vehicle. For interstate driving, light duty vehicles and trucks see a 73% and 67% decrease in energy consumption respectively. Greater improvement in energy efficiency is seen for urban driving as light duty and truck energy consumption decreases 84% and 89% respectively compared to traditional ICE vehicles. Results show the integration of an electric drive system and WPT dramatically reduce the energy consumption as a result of energy recovery through regenerative braking, elimination of engine idle, and the high efficiency of energy conversion associated with EVs.

The WPT coverage for urban roadways was evaluated using the UDDS drive cycle. The light duty WPT EV consumes an average power of 5.76 kW over this drive cycle. To maintain the SOC of the WPT EV, it is necessary to charge 28% of the drive cycle time at 20.75 kW power transfer (25 kW WPT infrastructure with a grid to vehicle

Table 2. Energy consumption results for ICE vehicle and WPT EV architectures presented in Wh mi<sup>-1</sup> for light duty vehicles and Class 8 trucks. Results for interstate and urban roadways are based on the HWFET and UDDS drive cycles, respectively.

Vehicle	Urban	Interstate
Light Duty ICE	1,807	1,375
Light Duty WPT EV	294	336
ICE Truck	8,005	4,958
WPT EV Truck	850	1,617

transfer efficiency of 83%). Due to the low speed and large number of stops occurring in the UDDS drive cycle, the actual roadway coverage is significantly less. Only 2.6% of the roadway needs to be covered in the UDDS drive cycle in order to meet the power demands of the WPT EV. It is possible and advantageous to place the WPT pads strategically in urban roadways to take advantage of stopping locations (i.e. traffic lights, stop signs, etc.) to decrease roadway coverage minimizing infrastructure costs and maximizing power transfer.

Similarly, the evaluation of the required WPT roadway coverage for the interstate system was evaluated based on the characteristics of the vehicle as it drives the HWFET drive cycle. The light duty WPT EV consumed an average of 17.6 kW of power throughout this drive cycle. Under these conditions, the WPT EV needs to receive power during 85% of the drive cycle time to maintain SOC. This represents a condition where 83.5% of the distance within the interstate system is required to be covered with in-motion WPT to maintain vehicle SOC. The modeling work assumes optimal WPT pad placement to minimize the roadway coverage, however due to the high speeds and low number of stops that are associated with highway driving, the roadway coverage can only be minimally decreased.

The total required roadway coverage in the U.S., based on the integration of vehicle models with interstate and urban representative drive cycles, is estimated at 65,839 miles, which corresponds to a total capital investment of \$316 billion at \$2.4 million lane<sup>-1</sup> mile<sup>-1</sup>. In total, this upgrade will impact 6% of interstate and urban roadways. Fifty-eight percent of the retrofitted roadway miles are interstate and 42% are urban. In the U.S., the urban roadway system has 23.4 times more paved miles compared

to the interstate system. Thus, the total capital costs for the deployment of the technology are more sensitive to the urban roadway coverage fraction than they are to the interstate coverage fraction.

### **Economic Feasibility**

Economic feasibility was determined by integrating vehicle level results with annual U.S. transportation data to understand the societal level impact. Total vehicle ownership costs were calculated for both ICE and WPT EVs and consisted of purchase, maintenance, and operational costs evaluated over the life of the vehicle. Societal feasibility was evaluated using a societal payback time defined as the time required for the total vehicle ownership cost savings of WPT EVs compared to traditional ICE vehicles to equal the capital investment of the roadway infrastructure.

Total vehicle level costs are shown on a per mile basis in Figure 5 for light duty WPT EVs and ICE vehicles on interstate and urban roadways. Light duty results show operational cost reductions for WPT EVs compared to ICE vehicles of 57% and 74% for interstate and urban driving, respectively. Similarly, there is a 48% reduction in Class 8 truck operational costs associated with interstate roadways. The greatest economic benefit is seen on urban roadways for the Class 8 trucks where there is an 83% reduction in operational costs. This is due to the large increase in energy efficiency that comes with urban EV operation. Over the 15 year life of the vehicle, operational costs of the WPT EV represent the largest fraction of total cost savings at 44% (\$15,717) and 79% (\$345,365) for light duty vehicles and Class 8 trucks, respectively. Over the life of WPT EVs, savings compared to traditional ICEs are greater than the WPT EV purchase costs.

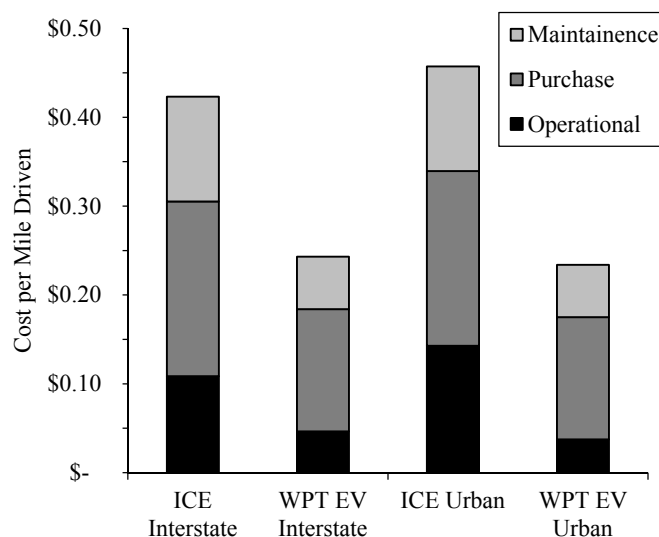

Figure 5. Light duty vehicle cost breakdown.

Total vehicle level savings equate to 1.5X (\$35,789) and 4.1X (\$435,365) the purchase price for light duty vehicles and Class 8 trucks, respectively. These results highlight the economic benefits of the WPT technology compared to traditional ICE vehicles. The large benefit of the WPT EV technology is rooted in improved energy utilization efficiency and decreased overall purchase and maintenance costs.

Vehicle energy and infrastructure requirement results were used in conjunction with U.S. transportation data to understand the cost of the technology on a societal level. A payback time was calculated based on the total time required for the ownership cost savings associated with WPT EVs compared to ICE vehicles to equal roadway infrastructure costs with results presented as a function of fleet penetration of WPT EVs, Figure 3. Both payback time and fleet penetration use a combination of light duty vehicles and Class 8 trucks based on miles driven for each vehicle class as outlined by U.S. transportation data. Figure 6 shows the results of the baseline scenario with a



sensitivity to roadway coverage as a 10% increase or decrease of the baseline. For a 10% fleet penetration, the urban and interstate system sees a payback time of 5.9 years. Both payback time for the electrified roadway system and sensitivity to roadway coverage decrease as WPT EV fleet penetration increases. At an increased fleet penetration of 20%, the urban and interstate system sees the payback time decrease to 3.0 years. As mentioned in the previous section, the cost of interstate roadway coverage is minor compared to urban roadway coverage. For each 1% increase in roadway coverage, the urban system expands an additional 10,682 miles compared to an increase of only 456 miles for the interstate system. As the WPT system is utilized, roadway infrastructure expansion is expected based on traffic patterning. If the required roadway coverage in the

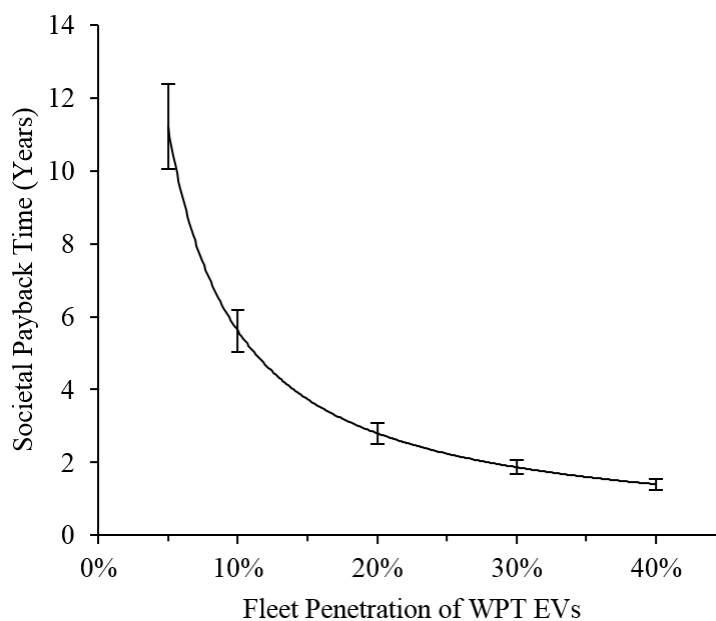

Figure 6. Societal payback time, defined as the time for ownership savings associated with WPT EVs compared to ICE vehicles to be equal to roadway infrastructure costs, of WPT infrastructure as a function of fleet penetration. Error bars represent the span of payback time corresponding to  $\pm 10\%$  roadway coverage compared to baseline.

urban sector is doubled to 5.2%, the payback time only increases to 8.5 years at a 10% fleet penetration of WPT EVs. This conservative assessment shows the payback time's resiliency to changes in roadway coverage. The WPT EV technology represents an economically promising transportation alternative to current ICE based systems with payback times of less than 10 years for various scenarios and reductions in operational vehicle costs of greater than 50%.

### **Recouping Infrastructure Costs**

Recovering the large upfront costs of retrofitting roadways represents a challenge associated with the economics of this technology. The substantial operational savings compared to an ICE vehicle of 8.4¢ per mile (\$950 per year) for a light duty vehicle make the technology desirable to the consumer. Charging a set amount per kWh of electricity transferred to the WPT EV represents one option for infrastructure reimbursement. This system uses a baseline scenario where the vehicle owner receives a 25% energy cost savings compared to ICE vehicles with the remaining savings, 75%, being used to recover infrastructure costs. The vehicle operation savings are calculated using the U.S. Department of Energy's eGallon, defined as how much it costs to drive an EV the same distance you could go on a gallon of fuel in a similar ICE vehicle while taking into account both electricity and fuel prices [45]. In this system, the total electricity cost increases by various usage amounts based on the type of vehicle (light duty or Class 8 truck) and roadway (interstate or urban), Table 3. The various usage costs account for the different savings estimated for each vehicle and roadway combination while maintaining a 25% energy cost savings to the owner.

Table 3. Baseline usage costs per kWh for vehicle and roadway types based on a 25% owner's energy savings.

	Interstate		Urban	
Light Duty	\$	0.10	\$	0.24
Class 8 Truck	\$	0.05	\$	0.43

Figure 7 presents the payback time as a function of operational vehicle owner savings at multiple fleet penetrations of WPT EVs. As expected, payback time increases as owner operational savings increase. While maintaining significant economic benefit for the vehicle owner, this plan provides a payback time of 18.7 years at a 10% fleet penetration of WPT EVs. Payback time is also heavily dependent on the WPT EV fleet penetration. If fleet penetration is increased to 20%, the payback time is dramatically

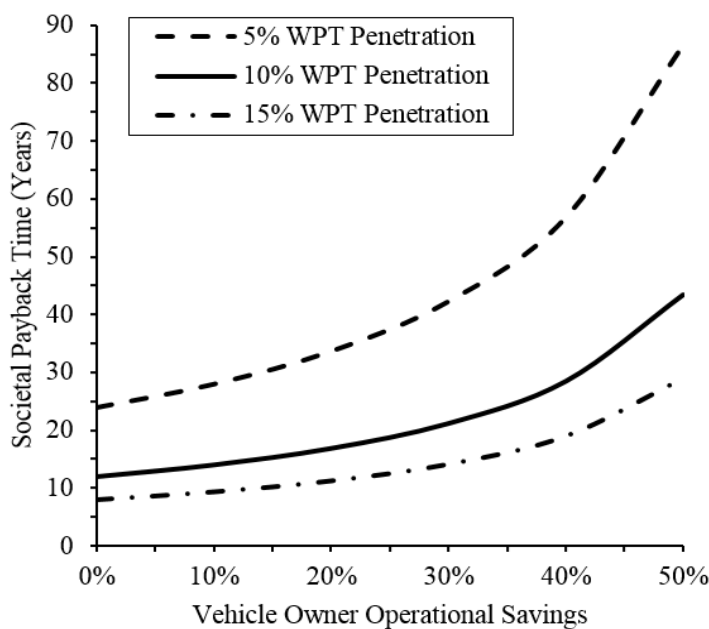

Figure 7. Societal payback time as a function of vehicle owner operational savings at a baseline 10% WPT EV fleet penetration. Sensitivity to fleet penetration at  $\pm 5\%$  is shown on the chart.

reduced to 9.4 years at the 25% owner savings. It is expected that the roadway WPT system will integrate communication to record energy transfer and bill end users appropriately. It is important to note that the energy transferred from the primary pad, not the power that is actually received, determines the end user's final bill. This ensures that the end user's focus is centered on maintaining high energy transfer efficiency and accurate alignment such that little energy is wasted through the transfer process. In addition to the economic benefits seen in this study, numerous studies have shown the environmental benefit of switching to an electrified transportation system [46, 47]. Integrating the minimal decrease in charging efficiency for the in-motion WPT charging compared to plug-in charging, it is expected that in-motion WPT would have a similarly positive environmental impact on the transportation sector.

### Conclusion

The integration of dynamic vehicle models with U.S. transportation data was used to perform an assessment of vehicle energy use, WPT roadway infrastructure requirements, and economic feasibility of WPT based transportation. The analysis of WPT roadway coverage to maintain SOC of WPT EVs shows it is necessary to cover 83.5% of interstate roadways and 2.6% of urban roadways with the WPT technology. Due to the frequent stops occurring on urban roadways and lower power consumption, the urban coverage is significantly lower than interstate coverage. The economics of this technology prove to be promising at both vehicle and societal levels. The implementation of this technology results in WPT EV owners seeing a decrease in total vehicle ownership

costs, compared to traditional ICE vehicles, greater than the purchase cost of their WPT EV over the life of the vehicle. If all vehicle operational savings compared to ICE vehicles are put towards reimbursing the large upfront roadway infrastructure costs, payback times on a societal level are shown to be less than 6 years at a 10% WPT EV fleet penetration. Integrating a reimbursement plan to provide WPT EV owners a 25% energy cost savings, the societal payback times are shown to be lower than 20 years at a 10% fleet penetration and decrease to less than 10 years at 20% fleet penetration. Results show that in-motion WPT to EVs represents a promising alternative technology to traditional ICE transportation.

This chapter evaluated the economic impact and presented an infrastructure reimbursement scheme for a WPT EV fleet using dynamic vehicle models integrated with standard drive cycles. Some of the key conclusions of this chapter are:

- The total required roadway coverage in the U.S., based on the integration of vehicle models with interstate and urban representative drive cycles, is estimated at 65,839 miles, which corresponds to a total capital investment of \$316 billion at \$2.4 million lane<sup>-1</sup> mile<sup>-1</sup>. In total, this upgrade will impact 6% of interstate and urban roadways.
- Total vehicle level savings equate to 1.5X (\$35,789) and 4.1X (\$435,365) the purchase price for light duty vehicles and Class 8 trucks, respectively.
- For a 10% fleet penetration, the urban and interstate system sees a payback time of 5.9 years. Both payback time for the electrified roadway system and

sensitivity to roadway coverage decrease as WPT EV fleet penetration increases.

- As expected, payback time increases as owner operational savings increase. If fleet penetration set at 20%, the payback time is equal to 9.4 years with 25% owner savings.

CHAPTER 3

SYSTEMS OPTIMIZATION OF DYNAMIC CHARGING OF ELECTRIC VEHICLES  
INTEGRATING WIRELESS POWER TRANSFER: ECONOMIC VIABILITY AND  
ENVIRONMENTAL IMPACT USING REAL WORLD DRIVE CYCLES AND  
VARIABLE FLEET PENETRATION AND DEPLOYMENT

Abstract

In-motion charging of electric vehicles (EVs) using wireless power transfer (WPT) represents a capable alternative to traditional internal combustion engine (ICE) transportation and current long-range EVs. This study focuses on understanding the economic feasibility, environmental impact and infrastructure optimization of in-motion WPT applied to the U.S. transportation fleet. Integrating geographically diverse real-world drive cycles with dynamic vehicle models and variable vehicle adoption and infrastructure deployment rates, the economic feasibility, environmental impact and infrastructure requirements were determined. Technology optimization results show that the vehicle characteristics of a WPT EV fleet will consist of a 25 mile range EVs with 2C stationary charging at locations stopped greater than one hour and 50 kW charging on high speed (greater than 30 MPH) primary and secondary roadways, representing a total infrastructure cost of \$1.45 trillion. When used in conjunction, optimized vehicle and roadway architectures satisfy 97.7% of 24-hour drive cycles, a 22.4% increase from when no in-motion charging is used. Economic results show a societal ROI, defined as the time required for the roadway infrastructure costs to be less than operational savings

associated with travel on electrified roadways by EVs excluding 25% of operational savings kept by the vehicle owner, of 36.7 years assuming a roadway retrofitting cost of \$2.5 million lane<sup>-1</sup> mile<sup>-1</sup> and an infrastructure deployment of 13,788 electrified roadway miles per year. Expanding models to evaluate the environmental impact shows that total emissions from light duty vehicles and Class 8 trucks will be reduced by 29.3 trillion kg CO<sub>2</sub>-eq. (30.6%) when compared to a business as usual scenario for the first 50 years of technology deployment. Overall, results show that in-motion charging using WPT presents both economic and environmental benefits when compared to conventional ICE transportation and a long range EV fleet.

## Introduction

Transportation is a primary consumer of energy across the globe with the majority of current systems relying exclusively on fossil based onboard energy storage systems. Increased development of alternative energy production combined with pressure to reduce emissions has resulted in the commercialization of a variety of electric based transportation vehicles including plug-in electric vehicles (PEVs), hybrid electric vehicles (HEVs), and fuel-cell vehicles (FCVs). However, consumer adoption and vehicle fleet penetration of these alternative technologies has been limited due to restricted range, long recharging times, and high total purchase price compared to traditional internal combustion engine (ICE) vehicles [12]. The current effort to reduce these limitations focuses on developing large onboard battery systems and high speed stationary chargers, despite the associated added cost and weight to the vehicle [3]. To eliminate the



dependence associated with large onboard battery systems, alternative technology solutions such as in-motion charging of EVs using wireless power transfer (WPT) are being investigated. In-motion charging using WPT allows for long distance EV travel with decreased onboard energy storage size, reducing the large upfront cost associated with onboard energy storage. Limited work has been done evaluating the technical feasibility, operational requirements, economic viability, and environmental impact of a WPT EV fleet on U.S. roadways.

Previous evaluations of in-motion charging have focused on the economics and environmental impact of the technology with zeroth order modeling techniques [48, 49]. Modeling work was limited to average energy consumption based on standard drive cycles with the impact of the technology evaluated using historical transportation statistics [50, 51]. Work showed promising economic results with a return on investment (ROI) of 5.9 years for a vehicle fleet penetration of 10%. The fidelity of modeling was improved through the use of real world drive cycle data with results showing a ROI of 11.3 years with a 25% fleet penetration [52]. Additionally, each study has evaluated the required percent of roadways to be electrified. These results range from 86.5% coverage in the United Kingdom to 23.6% in the U.S. for short-range EVs. Similarly, only 4.9% coverage is required in California, U.S. for long range EVs [53]. While economic results from all studies prove promising, study limitations include instantaneous infrastructure roll-out, limited roadway infrastructure details, and a simplified calculation of ROI, which have led to questioning of study accuracy. Therefore, these limitations warrant more detailed evaluations.

This work is a realistic assessment of the potential impact and feasibility of the development of WPT applied to U.S. transportation. The modeling work utilizes dynamic vehicle models integrated with real-world drive cycles and variable vehicle adoption and infrastructure deployment rates to evaluate the economic feasibility and infrastructure requirements. Dynamic vehicle models, Geographic Information Systems (GIS), and GPS stamped real-world drive cycles enable an evaluation of the required roadway infrastructure and vehicle architecture to meet consumer needs. Results from roadway optimization and vehicle modeling are integrated with economic models to understand the feasibility of in-motion WPT for transportation in the U.S. Societal acceptability is investigated through multiple techniques ranging from satisfying drive cycles to individual vehicle owners. Discussion includes the feasibility of rolling out the required system necessary for in-motion charging using WPT, the effect of electrified roadway deployment on ROI, and an economic comparison to a long-range EV fleet.

## Methods

Dynamic charging of EVs using WPT requires both roadway and vehicle level components. As seen in Figure 1, this concept of dynamic charging utilizes an EV with limited onboard energy storage for short range travel between dynamic or stationary charging events. Communications between the roadway and vehicle are in place such that power is wirelessly transferred when the secondary pad on the vehicle comes into alignment with the primary pad embedded in the roadway. Therefore, the electric grid is the source of energy necessary to drive the vehicle and excess energy is delivered to the

onboard storage system.

To evaluate infrastructure requirements and onboard vehicle architecture solutions, a suite of dynamic vehicle models was developed. Both ICE and WPT EVs were modeled to assess the potential of the technology compared to current vehicle solutions. Evaluation of the WPT technology was assessed through integrating vehicle models with real world drive cycles. Detailed descriptions of the vehicle model development and validation, technology optimization, economic modeling, and environmental assessment are presented in the following sections.

### **Vehicle Modeling**

Dynamic vehicle models were developed for both light duty vehicles and Class 8 trucks to represent the majority (94%) of vehicle miles traveled in the U.S. [54]. Both WPT EV and ICE architectures were modeled for each vehicle class. The MATLAB/Simulink software was used for model development and all vehicle components required for real world vehicle simulation were included. All major vehicle components are represented by a subsystem designed to perform their associated function. Detailed descriptions of vehicle subsystems and their associated function are described in the following sections.

#### *Vehicle Dynamics and Control*

Consistent between both ICE and WPT EV models are the vehicle dynamics and control subsystems. The vehicle dynamics subsystem is responsible for calculating the main forces acting on the vehicle and additional braking forces. The main forces include: gravitational forces ( $G$ ), rolling resistance ( $R$ ), and drag force ( $D$ ) shown in Eqns. 1-3,

$$G = m * g * \sin \beta \quad (1)$$

$$R = Cr * m * g * \cos \beta \quad (2)$$

$$D = \frac{Cd * A * \rho * V^2}{2} \quad (3)$$

respectively. These forces are calculated using vehicle mass ( $m$ ), roadway grade ( $\beta$ ), rolling resistance coefficient ( $Cr$ ), frontal area ( $A$ ), drag coefficient ( $Cd$ ), vehicle velocity ( $V$ ), and air density ( $\rho$ ). The braking forces are calculated based off the requests sent from the torque controller. As both braking and vehicle forces slow down the vehicle, negative torques are added to the mechanical driveshaft to simulate this effect. The vehicle subsystem also contains constant inertias for the driveshaft and half shafts which are used to accurately calculate the speed of the driveshaft.

The control subsystem consists of two main components: the driver and powertrain controller models. The driver model compares the desired drive cycle velocity to the modeled vehicle's velocity with the result used to either increase or decrease torque. If an increase in speed is desired, the positive torque request is sent to the electric motor in the WPT EV model and to the engine in the ICE model. Contrarily, if a decrease in speed is desired, the negative torque request is sent to the generator in the WPT EV model and to the brakes in the ICE model. The negative torque request is used for regenerative braking in the EV architecture as supercapacitors can handle large charge rates.

### *WPT EV Powertrain Model*

The WPT EV Powertrain model includes a motor/generator connected to a fixed gear ratio transmission, a battery for energy storage, and a WPT system for receiving power. A torque request is sent from the torque controller to the motor/generator and, with the torque versus rpm curve known from experimental motor data, an output motor torque is calculated. Once calculated, the torque is sent to the vehicle's driveshaft using a torque actuator. Additionally, the motor/generator's efficiency is calculated using known efficiency curves from experimental data based on motor torque and revolutions per minute (rpm). The required electric energy from the onboard energy storage was then calculated using the motor/generator efficiency. Experimental motor data from the Nissan Leaf was used for all EVs and was scaled based on the maximum torque and power requirements of each vehicle system modeled.

Battery characteristics, current, state of charge (SOC), and performance are calculated within the battery subsystem. Using the known motor/generator power consumption, accessory power load requirements, and incoming wireless power amounts, the battery current demand is calculated. Associated internal resistance and open circuit voltage are determined using battery characteristics, current, SOC and battery temperature in conjunction with lookup tables based on experimental data. Subtracting the voltage loss due to internal resistance from the open circuit voltage, the actual battery voltage is calculated. Finally, output energy and battery SOC is determined at each time step using battery current and battery voltage. The characteristics of the battery subsystem are derived from, and validated against, the performance of the A123 20Ah 7x15s3p modules.

The WPT subsystem simulates real-world WPT from the grid connected WPT pads to the vehicle. The WPT subsystem includes a controller such that power is wirelessly transferred when user defined conditions are met. These conditions can include: vehicle speed, roadway classification, or set roadway distances. To ensure battery integrity, supercapacitors were used to handle large transient energy pulses associated with the WPT technology and regenerative braking [15-17]. Therefore, the power wirelessly transferred to the vehicle is sent first to a supercapacitor system. This supercapacitor subsystem includes a control algorithm such that the discharge power satisfies motor/generator and accessory load requirements first, with any excess used to charge the onboard batteries. Incoming wireless power is limited based on supercapacitor SOC. Supercapacitor discharge current limits battery charging to 2C levels to ensure battery integrity and life.

#### *ICE Powertrain Model*

The ICE powertrain model includes an engine subsystem connected to a variable 6 gear transmission subsystem. ICE performance is simulated in the engine subsystem using the engine torque request sent from the torque controller. Requested engine torque is compared to the rpm based maximum engine torque from experimental data, with the lower value applied to the mechanical driveshaft using a torque actuator. Additionally, fuel consumption is also calculated in the engine subsystem using engine torque and engine speed along with lookup tables based on experimental engine data. The engine subsystem outputs engine torque, engine speed, and fuel consumption. The transmission subsystem changes the gears of the ICE vehicle using a built in controller. The gear ratio

is changed by the controller based on engine speed and engine torque request.

### *Vehicle Characteristics*

Both light duty vehicle and Class 8 truck vehicle classes were modeled with the objective of representing the majority (94%) of vehicle miles traveled in the U.S. [54]. Based on information from the Bureau of Transportation Statistics and the U.S. Department of Energy, the average fuel economy of light duty vehicles and Class 8 trucks is 21.4 miles per gallon (MPG) and 5.8 MPG, respectively [18, 55]. Vehicle specifications were selected such that fuel economy of the modeled vehicles was equal to 21.4 MPG and 5.8 MPG averaged over the Urban Dynamometer Driving Schedule (UDDS) and Highway Fuel Economy Test (HWFET) drive cycles for light duty vehicles and Class 8 trucks, respectively. The specifications defined for each vehicle architecture are shown in Table 1. To provide an equal comparison between the two vehicle types, performance of the electric motor was scaled such that both WPT EV and ICE had the same 0–60 mph time.

While other alternative transportation options (PHEVs, FCVs, etc.) are currently on the market, they only make up a minor portion of the U.S. vehicle fleet. For example, PHEVs represent the middle ground between ICE vehicles and EVs. Researchers predicted that PHEV fleet penetration would reach 10-15% by 2015, but in reality fleet penetration of these vehicles only increased from 2.3% to 2.75% between the years 2007 and 2015 [9, 19-21]. While PHEVs experience similar economic and environmental benefits during operation as BEVs, large purchase prices compared to conventional vehicles have led to low adoption rates by consumers [19]. Because of this small fleet

penetration, alternative transportation options have been excluded from this analysis. However, in-motion charging technology using WPT can be coupled with all EV architecture types, including PHEVs, which could improve consumer acceptability of these technologies.

Overall, the grid to supercapacitor efficiency was assumed to be 83% for the WPT system [28, 29]. Due to the fact that Class 8 trucks can support multiple WPT receiving pads, the characteristics for the nationwide WPT infrastructure was designed for light duty vehicles. The longer length of Class 8 trucks can support the 5 receiving pads necessary to offset the largest difference in energy consumption (4.8X) seen between the two vehicle classes when averaged over the UDDS and HWFET drive cycles.

#### *Vehicle Model Validation*

To ensure dynamic vehicle model accuracy, validation was performed by comparing average energy consumption over standard drive cycles to results from Argonne National Laboratory's (ANL) Downloadable Dynamometer Database [56]. For each vehicle type, EV and ICE, multiple vehicles were used for validation. The vehicles modeled for the validation included the Nissan Leaf (EV), Mitsubishi i-MiEV (EV), Ford Focus Electric (EV), Ford Focus (ICE), and Toyota Corolla (ICE). Validation results were within 0.53%, 1.64%, 1.13%, 1.08% and 3.92% of expected energy for the Leaf (EV), i-MiEV (EV), Focus Electric (EV), Focus (ICE), and Corolla (ICE), respectively. All results were within 5% accuracy commonly accepted for dynamic vehicle models.

After validation, all vehicle models were scaled to represent the average fuel consumption of light duty vehicles and Class 8 trucks in the U.S. using the HWFET and



UDDS drive cycles. The light duty vehicle and Class 8 truck were within 2.0% (0.4 MPG) and 2.25% (0.1 MPG), respectively. After validation, ICE model vehicle specifications were used in the WPT EV models with the required energy management systems (WPT and supercapacitors) and drivetrain.

### **Infrastructure and Vehicle Optimization**

Technology optimization for in-motion charging using WPT was evaluated by running dynamic vehicle models using GPS-stamped real world drive cycles. Real world drive cycles from 6 geographically diverse locations across the U.S. (California; Southern California; Atlanta, GA; Chicago, IL; Kansas City, MO; and Texas) were obtained through the National Renewable Energy Laboratory's (NREL's) Transportation Data Center [57]. In order to perform roadway optimization, GPS-stamped drive cycles and associated roadway classifications were required. The optimization process was completed by concurrently altering roadway infrastructure and vehicle architecture. Within each geographically specific dataset, individual drive cycles were separated based on owner number, vehicle number, date, and the type of vehicle used to perform the given drive cycle. Vehicle types varied between datasets, but commonly ranged from sedan to pickup truck. As technology optimization was focused on satisfying light duty drive cycles, sedan and coupe drive cycles, representing 32.7% of the total drive cycles, were used for technology optimization. After optimization was completed, all available drive cycles (17,636 drive cycles from 6,254 vehicles) were evaluated with the optimized architecture to understand large scale satisfaction of the technology.

Vehicle architecture optimization took place with an emphasis on 1) drive cycle

satisfaction and 2) minimizing vehicle purchase cost and size. Drive cycle satisfaction was determined by simulating sedan and coupe drive cycles with various vehicle and roadway architectures to determine the energy consumption and battery SOC throughout the cycle. A drive cycle was deemed to be satisfied if its SOC remained above 0% throughout the drive cycle. If, at any point, the vehicle's SOC fell below 0% it was deemed the drive cycle was not satisfied.

Minimal vehicle cost and size were determined through varying onboard energy storage size, in-motion WPT level, and assumed stationary charge time. Onboard energy storage size ranged from 20 miles to 300 miles, with the later used for comparison to long range EV feasibility. In-motion WPT charging levels varied between 25 kW and 100 kW. In order to ensure battery integrity, supercapacitors were used to handle large transient energy pulses associated with the WPT technology. Based on the WPT charging levels used, the size of the supercapacitor bank was scaled using multiple Maxwell 48V modules [58]. The cost of batteries, wireless pads, and super capacitors were assumed to be \$230 kWh<sup>-1</sup>, \$20 kW<sup>-1</sup> of WPT power, and \$100 kWh<sup>-1</sup> respectively [59, 60]. The weight and volume associated with battery size, WPT charging levels, and supercapacitor size were based off a Nissan Leaf battery pack (140 Wh kg<sup>-1</sup> and 2.4e<sup>-5</sup> m<sup>3</sup> Wh<sup>-1</sup>), WiTricity WiT-3300 WPT pad (825 W kg<sup>-1</sup> and 1,833 kW m<sup>-3</sup>), and the Maxwell 48V modules (13.5 kg and 0.15 m<sup>3</sup>) [58, 61-63]. To simulate behaviors of current EV owners, stationary charging was assumed to occur at locations where the vehicle was stopped greater than set periods of time. These time periods ranged from no stationary charging to stationary charging at locations when the vehicle was stopped greater than 1 hour. Final component cost for batteries, wireless charging pads, and supercapacitors was compared

to the cost of the Nissan Leaf battery pack (\$5,499) [64] to determine the cost savings associated with each vehicle architecture. In total, 25 combinations of onboard energy storage, WPT charging levels, and stationary charging time were evaluated across 5,761 drive cycles.

#### *GPS Enabled Drive Cycle Data*

GPS enabled drive cycles were leveraged from NREL's Transportation Secure Data Center. For all studies analyzed (California; Southern California; Atlanta, GA; Chicago, IL; Kansas City, MO; and Texas), GPS-stamped drive cycle points were compared to known roadway locations and classifications. U.S. roadway classifications (Primary, Secondary, Local, etc.) were determined through the United States Census Bureau's Topologically Integrated Geographic Encoding and Referencing (TIGER) database. Once roadway type was known for all drive cycle points, the associated drive cycles were used for optimization work.

#### *Drive Cycle & Consumer Satisfaction*

Technology satisfaction was evaluated on multiple levels. First, satisfaction was evaluated individually for every 24 hour drive cycle within a given transportation study. Satisfaction was determined by running a given drive cycle through the dynamic vehicle model with a given vehicle architecture and roadway infrastructure. If the SOC of the vehicle fell below 0% at any point during the drive cycle, it was determined that the drive cycle was not satisfied. Contrarily, if the vehicle SOC remained above 0% for the entire drive cycle it was deemed that it was satisfied. This drive cycle satisfaction method was used for the vehicle architecture and roadway infrastructure optimization work.

In addition, societal acceptability was evaluated on a vehicle level. In order to give a higher fidelity estimate of how many vehicles this technology could satisfy, all drive cycles associated with a given vehicle were evaluated at the same time. If a single drive cycle associated with a vehicle was not satisfied, the vehicle (and all associated drive cycles) was assumed to not be satisfied by the technology. On average, each vehicle had 3.3 drive cycles associated with it. However, there was large variability in the number of drive cycles associated with each vehicle as a function of geographic location. For example, the Atlanta, California, and Chicago studies averaged 6.1 drive cycles per vehicle while the Texas study averaged only 1 drive cycle per vehicle.

While analyzing societal acceptability on a vehicle level provides more insight into real world vehicle satisfaction, only 3.3 drive cycles per vehicle is limited sample size. To get a better idea of how this technology would affect vehicles over their entire life, a Monte Carlo lifetime simulation was used. Because minimum battery SOC was used to determine drive cycle satisfaction, it was also used to perform the Monte Carlo analysis. To perform the Monte Carlo analysis, the mean and standard deviation of the minimum battery SOC for all drive cycles associated with a vehicle were calculated. Then, a normalized random number generator was used to generate a scaling factor associated with battery SOC. The scaling factor was multiplied by the standard deviation of the SOC and added to the mean of the SOC. This created a minimum battery SOC for every day over a vehicle's 15 year life. For each vehicle, all 5475 minimum battery SOC values were analyzed and if a single value fell below 0% SOC, the vehicle was assumed to not be satisfied over its lifetime.

## **Economic Modeling**

A techno-economic analysis was used to evaluate a societal level ROI of the technology. The societal level ROI was defined as the time required for the roadway infrastructure costs to be less than operational savings associated with travel on electrified roadways by EVs. To provide realistic results, it was assumed that the vehicle owner kept 25% of the operational savings on electrified roadways with the remaining 75% being used for infrastructure reimbursement. Each state's energy prices for both electricity and gasoline were set at the average cost of energy for each respective region according to the U.S. Energy Information Administration's short-term energy outlook costs in 2016, Figures 16 & 18 [65]. Over the life of the analysis, gasoline and electricity prices were assumed to increase 1.7% and 0.2%, respectively, per 25 years according to the U.S. Energy Information Administration's long-term energy outlook for 2016 [66]. The outlined ROI is used to understand the societal level feasibility and impact of the WPT technology.

Based on the average purchase price of vehicles in September 2016, light duty ICE vehicles and Class 8 trucks purchase prices were set at \$34,372 and \$150,000, respectively [67]. Literature has shown that WPT EVs allow for a large reduction in battery size compared to traditional EVs resulting in lower purchase costs, therefore it was assumed the purchase price of both light duty and Class 8 truck WPT EV's would be 30% cheaper than its ICE counterpart [28, 32]. Maintenance costs of ICE and WPT EVs were set at 4% and 2% of the purchase price per year, respectively, for both light duty vehicles and Class 8 trucks [33, 34]. Due to the fact that current EV OEMs warranty batteries for the life of the vehicle [35], battery replacement costs were excluded from

this analysis. Modeled vehicles were assumed to drive the average annual vehicle distance travel, or 11,287 miles year<sup>-1</sup> and 65,897 miles year<sup>-1</sup> for light duty vehicles and Class 8 trucks, respectively [54]. A 15 year lifetime was assumed for all vehicles [37].

The average baseline cost for retrofitting roadways with WPT is \$2.5 million lane<sup>-1</sup> mile<sup>-1</sup> [38, 39]. Due to large variability in the estimated retrofitting costs, a sensitivity analysis of  $\pm$  \$1 million from baseline was evaluated. These costs include roadway retrofitting (50%), WPT electronics (40%), and electric grid power delivery infrastructure (10%). This analysis does not include roadway expansion, as that is generally costly. Assumed deployment includes retrofitting 2 lanes, one in each direction, on roadways where the technology is deemed appropriate from optimization work. Maintenance costs associated with this system are expected to be covered through current roadway maintenance budgets as they have been demonstrated to be robust [39-42, 44].

Costs were evaluated first on a vehicle level and included operation, purchase and maintenance costs. The total purchase and maintenance costs were calculated over the vehicle's life, and were then divided by the vehicle's lifetime miles to get costs on a per mile basis. Operation costs were calculated using average energy consumption (Wh mi<sup>-1</sup>) resulting from the real-world drive cycle simulations. The average energy consumption was assumed to vary by state according to their proximity to the transportation studies analyzed, Figure 15. The assumed average energy consumption was multiplied by the energy cost (gasoline or electricity) from the respective region. The resulting value represented the operational costs on a per mile basis.

Vehicle level costs were then scaled to a societal level using the average vehicle miles traveled per classification of roadway in each state. With the total costs of each

technology (ICE and WPT EV) scaled to a societal level, a societal level ROI could be calculated for the technology. ROI was calculated by dividing the total roadway infrastructure costs by the annual operational savings seen by WPT EVs on electrified roadways compared to traditional ICE vehicles, excluding the 25% of operational savings kept by the vehicle owner.

In order to provide a realistic infrastructure deployment, the technology was assumed to be deployed based on the largest number of vehicle miles traveled per mile of roadway and the highest penetration of EVs per capita [54, 68-70]. Roadways were deployed on a state by state basis with roadways broken up into Interstate, Other Freeways and Expressways, Other Principal Arterial, and Minor Arterial for both urban and rural systems. It was assumed that Interstate and Other Freeways and Expressways were primary roadways and Other Principal Arterial and Minor Arterial were secondary roadways based on the definitions from the U.S. Department of Transportation and the U.S. Census Bureau [71, 72]. Based on this criteria, all primary roadways were electrified first followed by secondary roadways. This system was assumed to be deployed at a rate of 13,788 electrified roadway miles per year, which represents the average number of center-line miles of new roads built per year from 2000 to 2013 in the U.S., Figure 8. [73]. A sensitivity analysis of  $\pm 50\%$  of electrified miles deployed each year was also performed.

To approximate the variable fleet penetration of the technology, it was assumed that WPT EVs would be adopted at a scaled version of the microwave adoption rate in

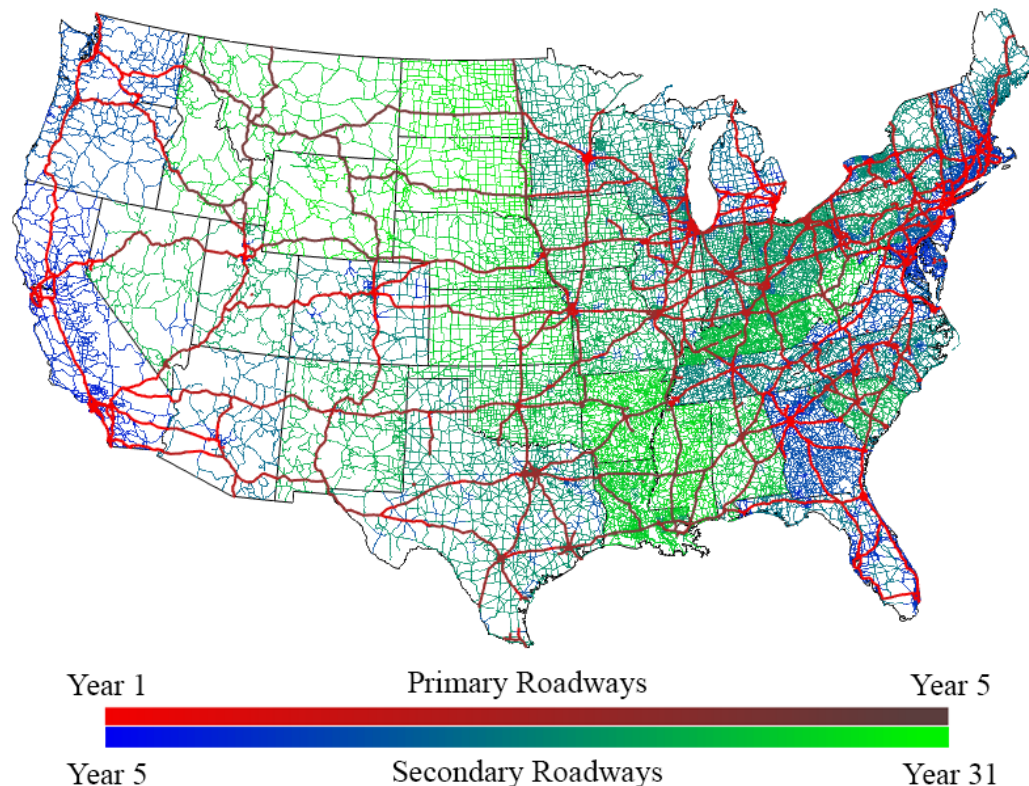

Figure 8. Map of assumed electrified roadway deployment at 13,788 miles per year. Light red lines represent primary roadways electrified first and dark red represent primary roadways electrified last. Blue lines represent secondary roadways electrified first and green lines represent secondary roadways electrified last.

Figure 9. Microwave penetration represents a middle case between the quick adoption of cell phones and the slow adoption of original automobiles. The microwave penetration rate was scaled for each state based on the percent of electrified roadways in that state. This variable penetration was assumed to begin when the first electrified roadways were constructed in a state and represented only a penetration of new vehicles purchased. Therefore, the percent microwave penetration for a given year was multiplied by the percent of total roadway deployment to give a final penetration rate within each state. Due to the rapid deployment of roadway infrastructure in some states, it was assumed that the fleet penetration rate could only increase 10% from one year to the next which



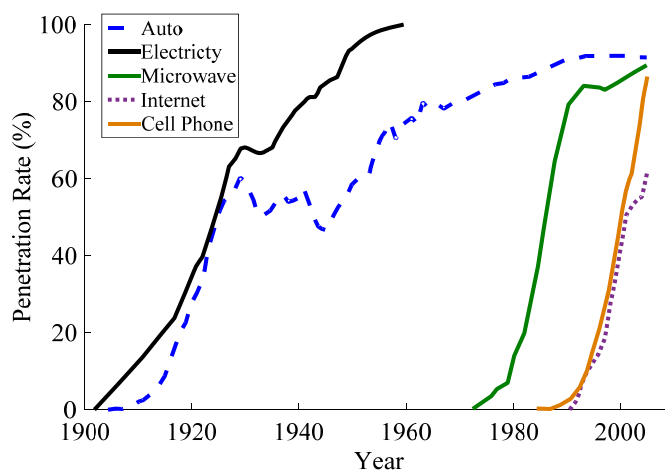

Figure 9. Historical technology penetration rates

represents the maximum increase in penetration rate seen during microwave adoption. In addition, the number of new vehicles purchased was assumed to equal 7.2% of registered vehicles [74, 75]. Class 8 trucks were assumed to have the same fleet penetration rates as light duty vehicles.

### Environmental Assessment

An environmental assessment was performed on both vehicle and societal levels. First, the environmental impacts of both traditional ICE and WPT EVs were evaluated. This was done by integrating life cycle inventory data from Argonne National Laboratory's GREET database with energy consumption results from the dynamic vehicle models for both vehicle architectures, ICE and EV [76]. For this analysis, emissions were only evaluated during the operational phase of the vehicle and excludes emissions from both vehicle manufacturing and electrified roadway deployment. Based on data in the GREET model, varying electricity compositions and associated greenhouse gas emissions were used based on the electricity region in which each state resides,

Figure 17. Additionally, it was assumed that the emissions associated with gasoline combustion equated to  $0.32 \text{ g-CO}_2 \text{ Wh}^{-1}$  based on GREET's analysis. Both electricity and gasoline emissions were multiplied by average energy consumption results to achieve emissions on a per mile basis. In addition to GHG emissions, criteria pollutants VOC, CO, NO<sub>x</sub>, PM<sub>2.5</sub>, PM<sub>10</sub>, and SO<sub>x</sub> were also evaluated.

Following the same deployment assumptions as the infrastructure rollout and variable WPT EV penetration on a state by state basis, the environmental impact was evaluated on a societal level. While economic savings were only assumed for driving on the electrified roadways, it was assumed that all vehicle miles driven for WPT EVs would have environmental benefits. This analysis allows for the environmental evaluation of the technology and shows how an electrified vehicle fleet compares to a traditional ICE vehicle fleet.

## Results and Conclusions

The results from the evaluation of in-motion wireless power transfer are divided into three sections, A) System optimization, B) Economic viability, and C) Environmental impact.

### **Optimization Results**

Modeling work focused on the optimization of two required systems, the vehicle architecture and the roadway infrastructure. Optimization work was performed concurrently as the two systems are directly coupled. The system architectures were evaluated initially on satisfying drive cycles. Limits on vehicle architecture and WPT

performance was based on near-term realizable performance.

*Vehicle Optimization:* The evaluation of the vehicle was performed through the integration of dynamic vehicle modeling with real-world drive cycles. The top results from the various architectures simulated are presented in Table 4. Integrating the results from this work with vehicle architecture size and cost, the optimized vehicle architecture was determined. It was found that an EV with 25 mile range battery, 50 kW of in-motion charging on high speed (speed limits greater than 30 MPH) primary and secondary roadways, and stationary charging at locations when the vehicle was stopped greater than 1 hour (i.e. home and work charging) will satisfy the vast majority of consumers (97.6%) with minimal vehicle mass and volume.

*Roadway Infrastructure:* There are 4.2 million miles of total paved roadway miles

Table 4. Optimization results for sedan and coupe drive cycles. Columns are colored based on desired result, green is positive and red is negative. High drive cycle satisfaction with low mass, low volume, and large capital cost reduction is desired. The selected optimized architecture is listed in bold.

Battery Range	WPT (kW)	Supercapacitor Modules	Drive Cycles Satisfied	Mass, kg	Volume, m <sup>3</sup>	Cost Reduction
20	0	0	73.6%	1387.3	0.12	\$ 3,557.36
25	0	0	70.7%	1395.9	0.15	\$ 3,279.44
30	0	0	83.7%	1404.5	0.18	\$ 3,001.52
35	0	0	87.1%	1413.2	0.21	\$ 2,723.60
20	25	13	91.4%	1593.1	0.32	\$ 2,988.72
25	25	7	91.0%	1520.7	0.26	\$ 2,742.48
25	25	10	94.5%	1561.2	0.31	\$ 2,726.64
25	25	13	96.0%	1601.7	0.35	\$ 2,710.80
30	25	13	97.3%	1610.3	0.38	\$ 2,432.88
35	25	13	97.7%	1619.0	0.41	\$ 2,154.96
<b>25</b>	<b>50</b>	<b>13</b>	<b>97.6%</b>	<b>1632.0</b>	<b>0.36</b>	<b>\$ 2,210.80</b>
25	50	20	99.0%	1726.5	0.46	\$ 2,173.84
30	50	13	99.0%	1640.7	0.39	\$ 1,932.88
30	50	17	99.3%	1694.7	0.45	\$ 1,911.76
35	50	10	98.8%	1608.8	0.38	\$ 1,670.80
25	100	50	98.6%	2192.1	0.93	\$ 1,015.44
300	0	0	99.6%	1870.6	1.77	\$ (12,006.09)

in the U.S. which is broken down into primary (1.6%), secondary (9.6%), and local (88.8%) classifications [70]. Even though local roadways represent the largest classification of paved roadways, only 27.6% (834 billion miles) of the annual vehicle miles occur on these roadways. The remaining 72.4% of vehicle miles occur on primary (1.0 trillion miles) and secondary (1.2 trillion miles) roadways [54]. Roadway infrastructure optimization was used to determine required deployment for in-motion WPT. These results show that only high speed (speed limits greater than 30 MPH) primary and secondary roadways need to be electrified to satisfy real world drive cycles. In total, this represents electrifying 603,898 lane-miles of paved roadways in the U.S. equaling a total capital cost of \$1.45 trillion. This is broken down into 81,928 lane-miles of primary roadways and 521,964 lane-miles of secondary roadways resulting in a capital costs of \$0.2 trillion and \$1.25 trillion, respectively. Deployment of the technology would impact 7.0% of the paved lane-miles in the U.S. The need to not electrify local roadways represents a significant infrastructure cost savings as a whole. The optimized system assumes the availability of 2C stationary charges.

*Societal Acceptability:* The initial societal acceptability analysis was focused on satisfying real world drive cycles. The performance of the technology was evaluated on a more holistic level through further data reduction based on vehicle tracking and Monte Carlo assessment. On the drive cycle level, satisfaction was evaluated individually for every 24-hour drive cycle within a given transportation study. If the SOC of the vehicle fell below 0% at any point during the drive cycle, it was determined that the drive cycle was not satisfied. Contrarily, if the vehicle SOC remained above 0% for the entire drive cycle it was deemed that it was satisfied. In order to give a higher fidelity estimate of how

many vehicles this technology could satisfy, all drive cycles associated with a given vehicle were evaluated at the same time. If a single drive cycle associated with a vehicle was not satisfied, the vehicle (and all associated drive cycles) was assumed to not be satisfied by the technology. A direct comparison of the performance of the technology based on drive cycle and vehicle level is presented in Table 5. For each scenario, results for both in-motion charging on high speed primary and secondary roadways is shown along with the results for no in-motion charging. All other variables (25 mile battery range and stationary charging at locations when stopped greater than 1 hour) were held constant between the two scenarios. Vehicle mass was varied in the two scenarios to take into account the added mass of the secondary WPT pad and associated electronics on the vehicle. The results for the vehicle metric are less than that of the drive cycle metric, as expected. This metric is more realistic of the probability of the technology satisfying a consumer as it is assumed if any of the drive cycles attached to a vehicle are not satisfied all of the corresponding drive cycles associated with that vehicle are not satisfied.

Table 5. Percent of drive cycles and vehicles satisfied when in-motion charging is and is not used including a comparison to an all-electric EV (300 mile range). Satisfaction is determined by evaluating minimum battery SOC of drive cycles. If battery SOC remains above 0%, the drive cycle is assumed to be satisfied. The vehicle level analysis evaluated multiple drive cycles at the same time. If one drive cycle was not satisfied, the entire vehicle was assumed to not be satisfied.

Study	<i>No In-Motion Charging</i>				<i>In-Motion Charging</i>		<i>Drive Cycle Quantity</i>	<i>Vehicle Quantity</i>
	<i>Drive Cycle 25 Mile</i>	<i>Vehicle 25 Mile</i>	<i>Drive Cycle 300 Mile</i>	<i>Vehicle 300 Mile</i>	<i>Drive Cycle 25 Mile</i>	<i>Vehicle 25 Mile</i>		
Atlanta	70.5%	38.6%	99.4%	97.7%	98.9%	95.6%	8,586	1,641
California	75.1%	46.3%	99.6%	98.2%	93.0%	82.8%	3,255	676
Chicago	79.9%	54.4%	99.8%	99.4%	99.3%	97.2%	1,625	362
Kansas City	73.6%	73.3%	100.0%	100.0%	98.9%	98.9%	360	352
Texas	86.3%	86.3%	100.0%	100.0%	98.2%	98.2%	2,597	2,597
Southern California	79.9%	70.9%	100.0%	100.0%	97.7%	96.5%	1,213	626
<b>Total</b>	75.3%	65.4%	99.6%	99.2%	97.7%	95.7%	17,636	6,254
<b>Total: Atl, Cal. &amp; Chi.</b>	72.8%	42.7%	99.5%	98.1%	97.5%	92.6%	13,466	2,679

On the drive cycle level, results show that 97.7% of 24-hour real world drive cycles can be satisfied by integrating in-motion charging with short range EVs. Comparatively, only 75.3% of drive cycles can be satisfied with a short range EV and no in-motion charging, a 22.4% difference between the two cases. A more significant difference is seen by moving to the vehicle level. On a vehicle level, 95.7% of the short range EVs are satisfied by using in-motion charging, while only 65.4% are satisfied with no in-motion charging in place, a 30.3% difference between the two cases. Of note, some discrepancies can be seen between drive cycle satisfactions for particular studies. For example, California has only 93% drive cycle satisfaction compared to greater than 97% satisfaction for the remaining studies. This is explained by the fact that drivers drove 5X more on high speed local roads than in the other studies while maintaining similar drive cycle time. Additionally, Texas had significantly higher drive cycle satisfaction for EVs using no in-motion charging. This is explained by the second shortest drive cycle time, 18.5% below average, and a significant amount of driving on low speed (less than 30 mph) local roadways. Low speed travel on local roadways is ideal for EVs due to regenerative braking and nonexistent engine idle. The results illustrated through both drive cycle and vehicle metrics show the defined technology to be promising in terms of satisfying drive cycles and consumers.

The potential of the technology was further evaluated through a Monte Carlo analysis, due to limited real world drive cycle data. The work focused on evaluating performance based on the average battery state of charge for the available drive cycle data. Results from this modeling work are presented in Table 6. The largest difference

Table 6. Percent of Monte Carlo vehicles satisfied when in-motion charging is and is not used including a comparison to an all-electric EV (300 mile range). Satisfaction is determined by evaluating minimum battery SOC of drive cycles. If battery SOC remains above 0%, the drive cycle is assumed to be satisfied. The Monte Carlo level analysis included one drive cycle for each day over the vehicle's 15 year life and drive cycles evaluated all drive cycles at the same time. If one drive cycle was not satisfied, the entire vehicle was assumed to not be satisfied.

Study	No In-Motion Charging		In-Motion Charging	Quantity
	25 Mile	300 Mile	25 Mile	
Atlanta	21.5%	95.0%	85.0%	1,641
California	32.7%	95.0%	72.2%	676
Chicago	35.4%	97.7%	89.9%	362
Kansas City	77.3%	98.6%	99.7%	352
Texas	89.0%	98.2%	98.8%	2,597
Southern California	58.0%	85.2%	92.1%	626
<b>Total</b>	58.3%	95.7%	91.2%	6,254
<b>Total: Atl, Cal. &amp; Chi.</b>	26.2%	95.4%	82.4%	2,679

between the in-motion charging and no in-motion charging scenarios is seen in the Monte Carlo results. Ninety-one percent of Monte Carlo vehicles are satisfied when in-motion charging is used, whereas only 58.3% of vehicles are satisfied when no in-motion charging takes place. Therefore, there is a 32.9% difference between the two scenarios over the lifetime of the vehicle.

Some studies have low drive cycle per vehicle ratios, and therefore cannot provide a representative sample size for the Monte Carlo analysis. Taking this into account, a Monte Carlo analysis was also performed for only vehicles that have 5 or more drive cycles associated with them. These results would provide more accurate representation of lifetime vehicles. The results from this analysis show that 79.0% of Monte Carlo vehicles can be satisfied with in-motion charging, whereas only 17.4% of vehicles can be satisfied without it. While both satisfaction values decreased from the

previous analysis, the difference between the two scenarios increases significantly to 61.7%. This shows that this technology could increase satisfaction of low range EVs more than once thought.

Overall, results show that electrified roadways have the capability to increase consumer satisfaction of low-range EVs by 30% at minimum. Low-range EVs integrated with in-motion charging not only have the capability to overcome the range anxiety currently plaguing the adoption of EVs, but also reduce the purchase price of EVs making them cheaper than conventional ICE vehicles.

An alternative solution to in-motion charging is the continued advancement of onboard energy storage. The assessment of a long-range (300 mile) BEV was evaluated on the three metrics described. As expected, the performance of this vehicle architecture is promising. Significant advantages are associated with this concept as there is minimal infrastructure requirements. However, moving the U.S. fleet to this type of system requires unrealistic advancements in battery technology. Batteries would need to weigh less, cost less, and have improved charging characteristics [77, 78]. Further, through preliminary assessment the resource requirements for the development of large battery systems that meet U.S. needs is un-sustainable and cost prohibitive. The total cost for deploying large-battery systems across the U.S. fleet will be \$1.9 trillion assuming the expected battery cost in 2020 of \$100 kWh<sup>-1</sup>, or 1.3X more than the outlined roadway infrastructure cost [79].



## Economic Feasibility

Economic results were evaluated first on a vehicle level and then on a societal level. For each vehicle class (light duty vehicle or Class 8 truck) and architecture (ICE or WPT EV), economic costs were averaged over the lifetime vehicle miles traveled and consisted of operation, maintenance, and purchase costs, Figure 10. For presentation purposes, the operational costs in Figure 10 are a weighted average of state level results based on vehicle miles traveled on primary and secondary roadways. On average, costs decrease by 44.8% and 63.1% for light duty vehicles and Class 8 trucks, respectively, when moving from an ICE architecture to a WPT EV architecture. The largest savings are seen within the operation phase for both vehicle classes at 66.2% and 72.7% for light duty vehicles and Class 8 trucks, respectively. Similar results have been presented based

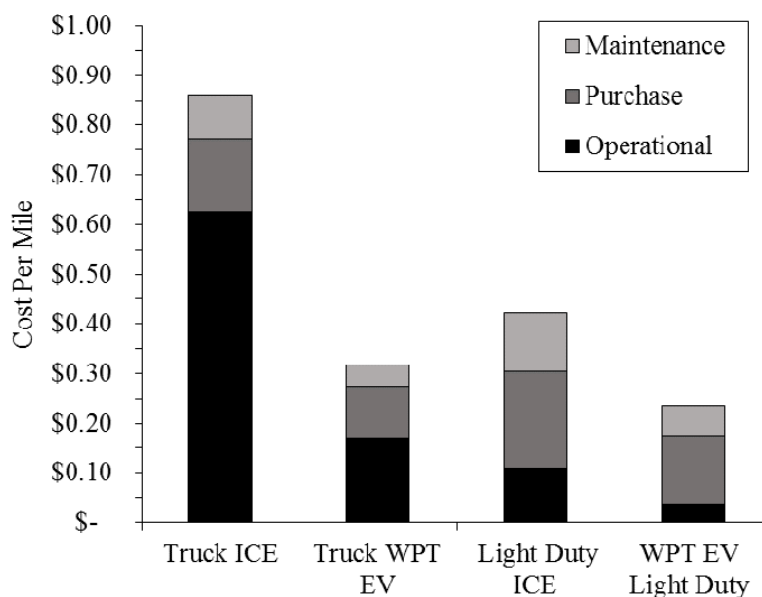

Figure 10. Vehicle level costs for each vehicle class and architecture type. For the results presented, the operational costs are a weighted average of state level operational costs based on vehicle miles traveled on primary and secondary roadways

on moving from fossil based transportation to electric transportation [80]. The evaluated technology sees additional savings based on the decreased weight of the overall vehicle compared to traditional electrical solutions, PHEV, BEV, and HEV solutions.

Integrating vehicle level economic results with U.S. Department of Transportation statistics allows for the evaluation of the societal feasibility of the technology. The feasibility is based on the payback time, defined as the time required for the operational savings associated with WPT EVs on electrified roads to equal the initial capital investment required for deployment of infrastructure on U.S. roadways. Additionally, the presented scenario assumes that 25% of the operational savings on electrified roadways go back to the vehicle owner with the other 75% going to pay off infrastructure. Nine cases were evaluated using the state by state infrastructure deployment and associated variable fleet penetration of the technology. The baseline scenario assumes that the number of roadway miles electrified each year is equal to the average number of center-line miles of new roads built per year from 2000 to 2013 in the U.S. (13,788 miles) and a retrofitting cost of 2.5 million  $\text{lane}^{-1} \text{mile}^{-1}$ . Due to unknowns associated with the rate of infrastructure deployment and roadway retrofitting costs, sensitivity analyses of  $\pm 50\%$  of the annual infrastructure deployment and  $\pm \$1$  million  $\text{lane}^{-1} \text{mile}^{-1}$  was also performed.

For the baseline cost and deployment scenario, a payback time of 36.7 years is seen, Figure 11. Results show that payback time is more sensitive to roadway cost than infrastructure deployment scenario. Between the two infrastructure deployment extremes, payback time varies from 4.5 years to 9.5 years depending on roadway retrofitting cost. Conversely, payback time varies from 8.4 years to 13.4 years between  $\$1.5$  million  $\text{lane}^{-1} \text{mile}^{-1}$  and  $\$3.5$  million  $\text{lane}^{-1} \text{mile}^{-1}$ , depending on infrastructure deployment. Overall,

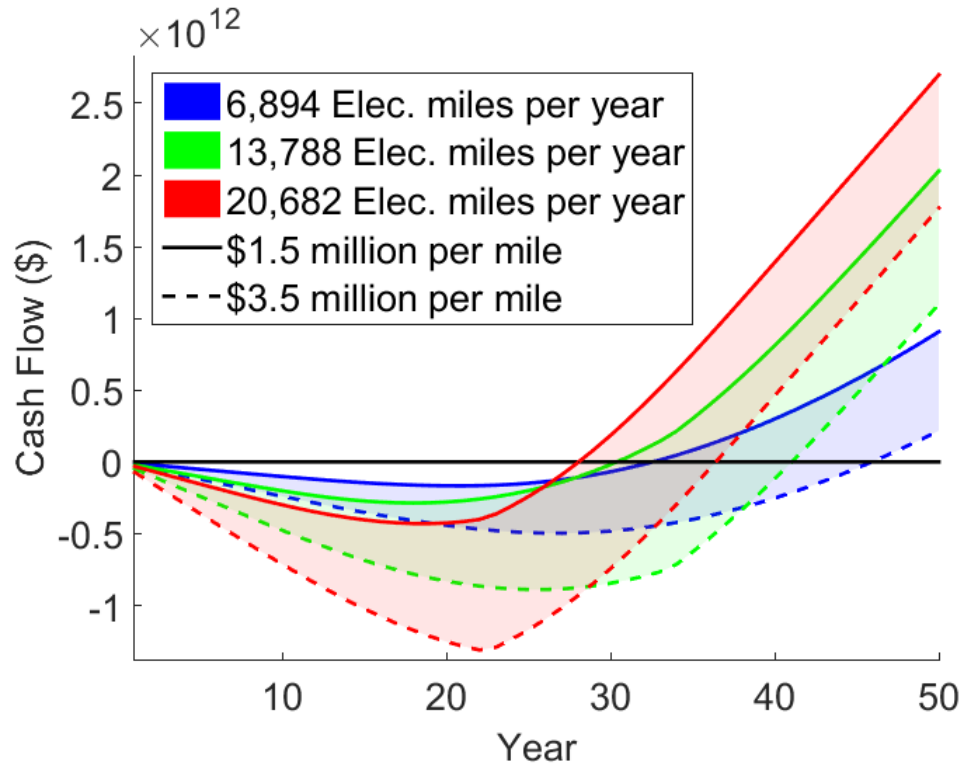

Figure 11. Societal cash flow curves for varying roadway miles electrified each year. Sensitivity between roadway retrofitting costs of  $\$1.5 \text{ million mile}^{-1} \text{ lane}^{-1}$  and  $\$3.5 \text{ million mile}^{-1} \text{ lane}^{-1}$  is also presented.

the +50% infrastructure deployment scenario sees the largest cost deficit but also the quickest fleet penetration leading to the shortest payback times between 28.1 years and 36.4 years, depending on retrofitting costs. Conversely, the -50% scenario sees the smallest cost deficit and the slowest fleet penetration of WPT EVs, leading to the longest payback times between 32.6 years and 45.9 years, depending on retrofitting costs. The baseline scenario falls in the middle of the two scenarios for both cost deficit and fleet penetration and has the middle payback time between 30.4 years and 41.0 years, depending on retrofitting costs. If all operational savings on electrified roadways goes back to pay for infrastructure, the payback times for the technology decrease to 35.2

years, 33.4 years, and 29.9 years for the -50%, baseline, and +50% infrastructure deployment scenarios respectively at a retrofitting cost of \$2.5 million lane<sup>-1</sup> mile<sup>-1</sup>.

Depending on the determined urgency of deploying this technology, the best scenarios prove to be those that have the largest initial infrastructure deployment and quickest WPT EV fleet penetration. After the initial deployment is paid back, further infrastructure deployment can take place to expand the electrified roadway network as the system generates revenue. After the +50% scenario at baseline cost is paid back, a revenue generation of \$116 billion occurs annually. Re-investment of this money would result in 46,500 lane-miles electrified per year.

As was discussed previously in the results section, the optimized vehicle architecture and roadway infrastructure satisfies 97.7% of consumers daily drive cycles. Therefore, 2.3% of drive cycles are left not satisfied by this architecture. In an effort to understand the costs associated with satisfying all drive cycles, an analysis was completed with varying roadway infrastructure deployment to understand the cost required for drive cycle and vehicle satisfaction based on infrastructure cost. Satisfaction for both drive cycle and vehicles using in-motion charging was evaluated for three varying infrastructure deployment scenarios. These scenarios include in-motion charging on the optimized infrastructure (primary and secondary roadways with speed limits greater than 30 MPH), all primary roadways, and all paved roadways (primary, secondary, and local) with speed limits greater than 60 MPH. A linear regression curve fit was applied to these three data points to estimate the cost for drive cycle and vehicle satisfaction with the technology. A 4<sup>th</sup> data point illustrates the drive cycle and vehicle satisfaction when no in-motion charging is in place. For all scenarios, a 25 mile battery

range, in-motion charging at 50 kW, and stationary charging at locations stopped greater than 1 hour was assumed for all vehicles.

The resulting curve for drive cycle satisfaction exponentially increases from the case when no in-motion charging takes place (72%) up to \$2.26 trillion for 100% drive cycle satisfaction, Figure 12. In order to achieve the last 2.3% of drive cycle satisfaction, an additional capital investment of \$0.8 trillion is required corresponding to an infrastructure cost 1.5X more than the original investment that satisfies 97.7%. Additionally, the vehicle satisfaction curve has a more gradual increase with a larger capital investment for 100% satisfaction at \$2.47 trillion, an additional \$1.0 trillion over

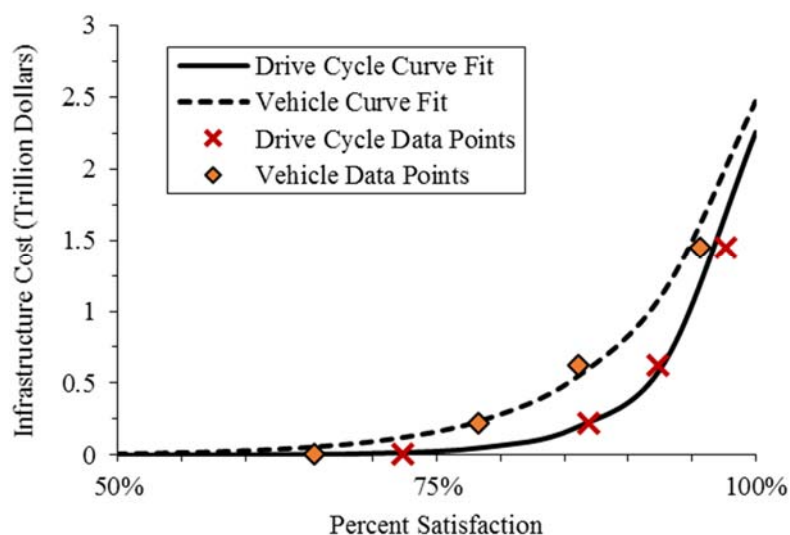

Figure 12. Cost to satisfaction curve for real world drive cycles and vehicles. Satisfaction for both drive cycle and vehicles using in-motion charging was evaluated for three varying infrastructure deployment scenarios. These scenarios include in-motion charging on the optimized infrastructure (primary and secondary roadways with speed limits greater than 30 MPH), all primary roadways, and all paved roadways (primary, secondary, and local) with speed limits greater than 60 MPH. A linear regression curve fit was applied to these three data points to estimate the cost vs drive cycle and vehicle satisfaction curves associated with the technology. Data point 4 illustrates the drive cycle and vehicle satisfaction when no in-motion charging is in place.

the baseline case. However, results show that this technology is expected to make a profit of \$124 billion annually once all high speed primary and secondary roadways are electrified representing a significant opportunity to electrify other roadways and improve technology adoption.

### Environmental Results

Results comparing the vehicle level environmental impacts of both conventional ICE vehicles and WPT EVs is shown in Figure 13. All criteria pollutants, except for PM<sub>2.5</sub> and SO<sub>x</sub>, decrease by moving to an electrified transportation system. Both PM<sub>2.5</sub> and SO<sub>x</sub> increase due the large amount of coal that is used for electricity generation in the Midwestern region of the U.S. An average reduction of GHGs of 66.0% and 72.2% is experienced by moving from ICEs to WPT EVs for light duty vehicles and Class 8

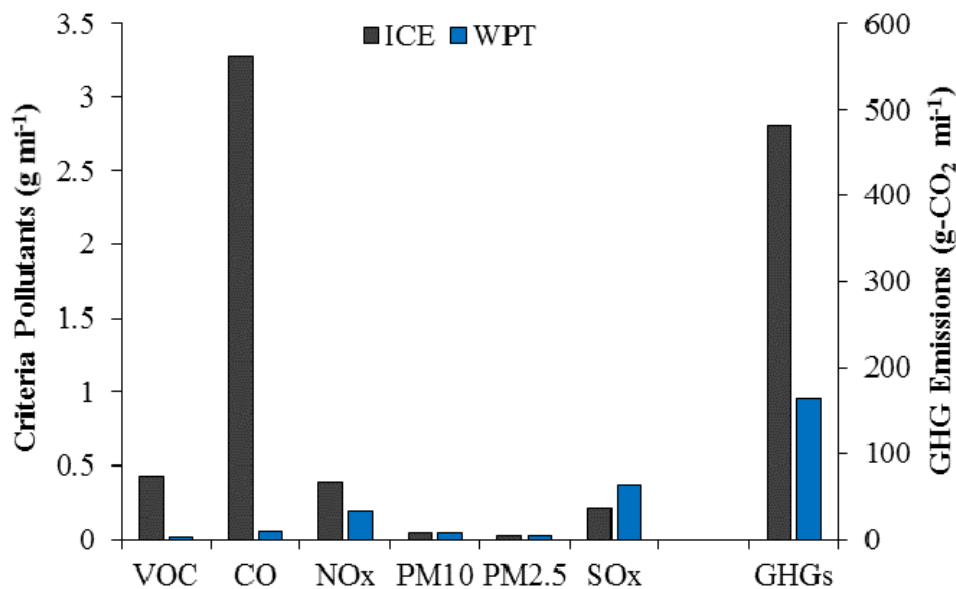

Figure 13. Environmental impact comparison of light duty ICE vehicle and WPT EV for U.S. Results presented are a weighted average of state level results based on vehicle miles traveled on primary and secondary roadways.

trucks, respectively. However, large differences in environmental impact are seen depending on geographic location. These GHG savings range from 35.3% and 48.8% for light duty vehicles and Class 8 trucks, respectively, in Hawaii to 81.4% and 84.7% for light duty vehicles and Class 8 trucks, respectively, in Connecticut. These results are consistent with other studies evaluating the environmental benefits of moving to an electrified transportation system [46, 81].

Expanding the environmental results on a vehicle level to a societal level shows the benefits that in-motion charging can have on a large scale. Figure 14 depicts the total amount of GHG emissions from light duty vehicles and Class 8 trucks with a variable technology adoption in the U.S. Each vehicle class is also broken down into ICE and

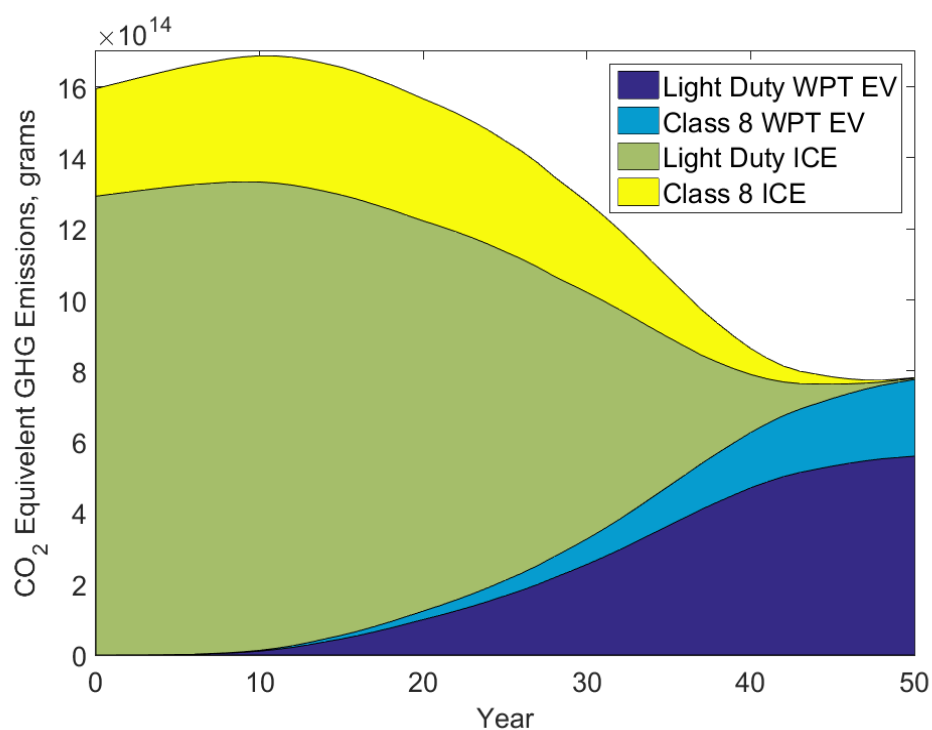

Figure 14. Varying emissions from light duty vehicles and Class 8 trucks as the in-motion WPT technology is adopted.

WPT EV architectures to depict the amount of GHG emissions coming from each unique transportation architecture. Using the same state by state infrastructure deployment and associated variable fleet penetration of WPT EVs as the economic results, temporally resolved emissions are estimated. As can be seen in Figure 14, as WPT EVs replace ICE vehicles the overall emissions from the transportation sector decrease as do the emissions from the ICE vehicles. By year 63, all ICE vehicles are expected to be replaced by WPT EVs and therefore no remaining transportation emissions are associated with the two ICE vehicle classes. A decrease of total emissions of 54.1% is seen at the end of 49 years when compared to the maximum expected transportation emissions which occur in year 11. The total emissions savings over the 50 year life of the system is 29.3 trillion kg CO<sub>2</sub>-eq. or a 30.6% reduction compared to a business as usual scenario.

## Conclusion

This study focused on understanding the large-scale impact of a WPT based transportation system. Utilizing dynamic vehicle models integrated with real-world drive cycles and variable vehicle adoption and infrastructure deployment rates, the economic and environmental feasibility of the technology was determined. Technology optimization results show that high speed (greater than 30 MPH) primary and secondary roadways need to be electrified to satisfy consumers. In total, this represents electrifying 603,898 lane-miles of paved roadways in the U.S. which equals a total capital cost of \$1.45 trillion. In addition, optimization results show that the vehicle characteristics of a WPT EV fleet will consist of a 25 mile range EVs with 2C stationary charging at



locations stopped greater than one hour and 50 kW charging on high speed primary and secondary roadways. When used in conjunction, optimized vehicle and roadway architectures satisfy 97.7% of 24-hour drive cycles and 95.7% of vehicles.

Comparatively, a 25 mile range EV with no in-motion charging will only satisfy 75.3% of drive cycles and 65.4% of vehicles.

By integrating vehicle optimization results with U.S. transportation data and variable vehicle adoption and infrastructure deployment rates, the societal level impact of the technology was evaluated. Economic results show a societal ROI, defined as the time required for the roadway infrastructure costs to be less than operational savings associated with travel on electrified roadways by EVs excluding 25% of operational savings kept by the vehicle owner, of 36.7 years assuming baseline roadway costs and deployment miles. In addition, a revenue of \$98 billion is generated annually after infrastructure reimbursement representing the potential to electrify an additional 39,000 lane-miles of electrified roadways. With reduced infrastructure cost and increased roadway deployment, ROI of the technology decreases to 29.9 years. Expanding models to evaluate the environmental impact shows that total emissions from light duty vehicles and Class 8 trucks will be reduced by 29.3 trillion kg CO<sub>2</sub>-eq. (30.6%) when compared to a business as usual scenario for the first 50 years of technology deployment. Overall, results show that in-motion charging using WPT presents both economic and environmental benefits when compared to conventional ICE transportation and a long range EV fleet. This chapter evaluated the economic impact and presented an infrastructure reimbursement scheme for a WPT EV fleet using dynamic vehicle models integrated with real-world drive cycles and variable fleet penetration and infrastructure

deployment. Some of the key conclusions of this chapter are:

- Technology optimization results show that the vehicle characteristics of a WPT EV fleet will consist of a 25 mile range EVs with 2C stationary charging at locations stopped greater than one hour and 50 kW charging on high speed (greater than 30 MPH) primary and secondary roadways.
- In total, 603,898 lane-miles of paved roadways in the U.S. will be electrified equaling a total capital cost of \$1.45 trillion at a retrofitting cost of \$2.5 million lane<sup>-1</sup> mile<sup>-1</sup>.
- When used in conjunction, optimized vehicle and roadway architectures satisfy 97.7% of 24-hour drive cycles, a 22.4% increase from when no in-motion charging is used.
- Economic results show a societal ROI, defined as the time required for the roadway infrastructure costs to be less than operational savings associated with travel on electrified roadways by EVs excluding 25% of operational savings kept by the vehicle owner, of 36.7 years assuming a roadway retrofitting cost of \$2.5 million lane<sup>-1</sup> mile<sup>-1</sup> and a infrastructure deployment of 13,788 electrified roadway miles per year.
- Total emissions from light duty vehicles and Class 8 trucks will be reduced by 29.3 trillion kg CO<sub>2</sub>-eq. (30.6%) when compared to a business as usual scenario for the first 50 years of technology deployment.

## CHAPTER 4

### CONCLUSIONS AND RECOMMENDED FUTURE RESEARCH

#### Conclusions

The transportation sector is one of the primary consumers of fossil fuels in the United States each year, accounting for 27 quadrillion BTU's of energy use annually. This equates to 27.7% of the total energy and 78% of the petroleum used by the United States each year. Drive to reduce fossil fuel dependence has resulted in the need for alternative vehicle technologies. Electric vehicles are one of the primary alternatives currently being pursued, however the acceptability of these vehicles is closely related to the range and purchase cost. The main component that contributes to range and cost is the battery. Increase in battery size results in more range, but also increases the cost and weight of the vehicle. In an effort to move away from the dependence on batteries there has been a push towards the implementation of in-motion charging of electric vehicles using wireless power transfer. In order to establish this technology as a feasible option it is necessary to understand the economics, environmental impact, and infrastructure requirements associated with deployment. Overall, this study aimed to directly assess the impact of a WPT EV fleet in the United States. After evaluating the technology using dynamic vehicle models integrated with both standard drive cycles and real-world drive cycles, the following conclusions can be reached:

- Results show the technology to be economically and environmentally promising on both vehicle and societal levels.

- Economic results are prove more feasible than both conventional ICE transportation systems and long range EVs.
- Vast satisfaction on both drive cycle and vehicle levels can be seen using short range EVs integrated with in-motion charging using wireless power transfer.
- Significant environmental benefits are expected compared to a business as usual scenario.

#### Recommended Future Research

- Gather additional transportation data and/or develop methods to simulate transportation behavior throughout the United States to ensure higher fidelity modeling results.
- Develop models to further understand the impact of in-motion charging on unique sectors of the transportation fleet. These include: commercial/fleet vehicles (drayage trucks, freight, local delivery, public transportation, etc.) and personal transportation (local, regional, and long haul commuting).
- Expand modeling efforts to understand economic and environmental impacts of comparative long distance transportation technologies (e.g. high-speed stationary charging, Hyperloop, bullet trains, etc.).

## REFERENCES

- [1] U.S. Department of Energy, *Transportation energy data book*, 2014.
- [2] U.S. Department of Energy. (2014). How much oil consumed in the United States comes from foreign sources? Energy Efficiency and Renewable Energy.
- [3] A. Gil and J. Taiber, "A literature review in dynamic wireless power transfer for electric vehicles: Technology and infrastructure integration challenges," in *Sustainable automotive technologies 2013*, ed: Springer, 2014, pp. 289-298.
- [4] D. W. Gao, C. Mi, and A. Emadi, "Modeling and simulation of electric and hybrid vehicles," *Proc. IEEE*, vol. 95, pp. 729-745, 2007.
- [5] B. M. Geller, "Increased understanding of hybrid vehicle design through modeling, simulation, and optimization," M.S. thesis, Dept. Mech. Engr., Colorado State Univ., Fort Collins, CO, 2010.
- [6] D. Karbowski, A. Rousseau, S. Pagerit, and P. Sharer, "Plug-in vehicle control strategy: From global optimization to real time application," in *22nd Electric Vehicle Symposium*, Yokohama, Japan, 2006.
- [7] M. A. Delucchi and T. E. Lipman, "An analysis of the retail and lifecycle cost of battery-powered electric vehicles," *Transport Res D-Tr E*, vol. 6, pp. 371-404, 2001.
- [8] B. M. Al-Alawi and T. H. Bradley, "Review of hybrid, plug-in hybrid, and electric vehicle market modeling studies," *Renew Sust Energ Rev*, vol. 21, pp. 190-203, 2013.
- [9] P. Balducci, "Plug-in hybrid electric vehicle market penetration scenarios," 2008.

- [10] X. Li, Y. Yang, and Y. Gao, "Visual prosthesis wireless energy transfer system optimal modeling," *Biomed Eng Online*, vol. 13, p. 3, 2014.
- [11] A. Kurs, A. Karalis, R. Moffatt, J. D. Joannopoulos, P. Fisher, and M. Soljačić, "Wireless power transfer via strongly coupled magnetic resonances," *Science*, vol. 317, pp. 83-86, 2007.
- [12] Z. Rezvani, J. Jansson, and J. Bodin, "Advances in consumer electric vehicle adoption research: A review and research agenda," *Transport Res D-Tr E*, vol. 34, pp. 122-136, 2015.
- [13] P. Balducci. (2008). Plug-in hybrid electric vehicle market penetration scenarios. PNNL.
- [14] T. Markel, A. Meintz, K. Hardy, B. Chen, and T. Bohn. (2015). Multi-lab EV smart grid integration requirements study. NREL.
- [15] J. M. Blanes, R. Gutierrez, A. Garrigós, J. L. Lizán, and J. M. Cuadrado, "Electric vehicle battery life extension using ultracapacitors and an fpga controlled interleaved buck–boost converter," *Power Electronics, IEEE Transactions on*, vol. 28, pp. 5940-5948, 2013.
- [16] M. Ortúzar, J. Moreno, and J. Dixon, "Ultracapacitor-based auxiliary energy system for an electric vehicle: Implementation and evaluation," *Industrial Electronics, IEEE Transactions on*, vol. 54, pp. 2147-2156, 2007.
- [17] E. Schaltz, A. Khaligh, and P. O. Rasmussen, "Influence of battery/ultracapacitor energy-storage sizing on battery lifetime in a fuel cell hybrid electric vehicle," *Vehicular Technology, IEEE Transactions on*, vol. 58, pp. 3882-3891, 2009.

- [18] Bureau of Transportation Statistics. (2014). Average fuel efficiency of U.S. Light duty vehicles. Transportation. [Online].
- [19] J. German, "Hybrid vehicles: Technology development and cost reduction," International Council on Clean Transportation, Web2015.
- [20] R. Ozaki and K. Sevastyanova, "Going hybrid: An analysis of consumer purchase motivations," *Energy Policy*, vol. 39, pp. 2217-2227, 2011.
- [21] D. L. Greene, K. Duleep, and W. S. McManus, "Future potential of hybrid and diesel powertrains in the us light-duty vehicle market," 2004.
- [22] A. Elgowainy, J. Han, L. Poch, M. Wang, and A. Vyas. (2009). Well-to-wheel analysis of energy use and greenhouse gas emissions analysis of plug-in hybrid electric vehicles. ANL. [Online].
- [23] G. Fontaras, P. Pistikopoulos, and Z. Samaras, "Experimental evaluation of hybrid vehicle fuel economy and pollutant emissions over real-world simulation driving cycles," *Atmos Environ*, vol. 42, pp. 4023-4035, 2008.
- [24] J. Kwon, J. Kim, E. Fallas, S. Pagerit, and A. Rousseau, "Impact of drive cycles on PHEV component requirements," SAE Technical Paper 2008-01-1337, 2008.
- [25] P. Sharer, R. Leydier, and A. Rousseau, "Impact of drive cycle aggressiveness and speed on HEVs fuel consumption sensitivity," SAE Technical Paper 2007-01-0281, 2007.
- [26] Office of Highway Policy Information. (2013). Public road length - 2013: Miles by type of surface and ownership/functional system national summary. Transportation. [Online].

- [27] Office of Highway Policy Information. (2013). Annual vehicle distance traveled in miles and related data - 2013. Transportation. [Online].
- [28] S. Lukic and Z. Pantic, "Cutting the cord: Static and dynamic inductive wireless charging of electric vehicles," *Electrification Magazine, Ieee*, vol. 1, pp. 57-64, 2013.
- [29] B. Song, J. Shin, S. Lee, S. Shin, Y. Kim, S. Jeon, *et al.*, "Design of a high power transfer pickup for on-line electric vehicle (olev)," in *Electric Vehicle Conference (IEVC), 2012 IEEE International*, 2012, pp. 1-4.
- [30] U.S. Energy Information Administration. (2015). Short-term energy outlook: September 2015. Department of Energy. [Online].
- [31] C. Talati, "New-car transaction prices continue to climb, up nearly 3 percent in July 2015, according to Kelley Blue Book," KBB, Irvine, CA, 2015.
- [32] M. Yilmaz and P. T. Krein, "Review of battery charger topologies, charging power levels, and infrastructure for plug-in electric and hybrid vehicles," *IEEE Trans. Power Electron.*, vol. 28, pp. 2151-2169, 2013.
- [33] G. Barnes and P. Langworthy. (2003). The per-mile costs of operating automobiles and trucks. Minnesota Department of Transportation. [Online].
- [34] P. Bansal, "Charging of electric vehicles: Technology and policy implications."
- [35] Ford Inc., "2013 model year ford hybrid car and electric vehicle warranty guide," Web2013.
- [36] M. Dickens, J. Neff, and D. Grisby, "APTA 2014 public transportation fact book," November, 2014.



- [37] A. Simpson, *Cost-benefit analysis of plug-in hybrid electric vehicle technology*: National Renewable Energy Laboratory Golden, 2006.
- [38] E. Burton, L. Wang, J. Gonder, A. Booker, and A. Konan, "Fuel savings potential from future in-motion wireless power transfer (WPT)," in *Conference On Electric Roads & Vehicles*, Park City, UT, 2015.
- [39] S. Jeong, Y. J. Jang, and D. Kum, "Economic analysis of the dynamic charging electric vehicle," *IEEE Trans. Power Electron.*, vol. 30, pp. 6368 - 6377, 2015.
- [40] A. Brecher and D. Arthur, "Review and evaluation of wireless power transfer (WPT) for electric transit applications," 2014.
- [41] J. Johnson, "Connected vehicle supported electric vehicle charging operations and related infrastructure issues," 2012.
- [42] X. She, A. Q. Huang, and R. Burgos, "Review of solid-state transformer technologies and their application in power distribution systems," *Emerging and Selected Topics in Power Electronics, IEEE Journal of*, vol. 1, pp. 186-198, 2013.
- [43] M. Rovito. (2014) On the right track. *Charged*. Available: <http://chargedevs.com/features/olev-technologies-dynamic-wireless-inductive-system-charges-vehicles-while-in-motion/>
- [44] U.S. Department of Transportation, "Budget highlights fiscal year 2016," 2016.
- [45] U.S. Department of Energy. (2013). eGallon: How much does it cost to drive an electric vehicle the same distance you could go on one gallon of gas? [Online].
- [46] T. R. Hawkins, O. M. Gausen, and A. H. Strømman, "Environmental impacts of hybrid and electric vehicles—a review," *The International Journal Of Life Cycle Assessment*, vol. 17, pp. 997-1014, 2012.

- [47] R. Faria, P. Moura, J. Delgado, and A. T. de Almeida, "A sustainability assessment of electric vehicles as a personal mobility system," *Energ Convers Manage*, vol. 61, pp. 19-30, 2012.
- [48] J. C. Quinn, B. J. Limb, Z. Pantic, P. Barr, and R. Zane, "Techno-economic feasibility and environmental impact of wireless power transfer roadway electrification," in *Wireless Power Transfer Conference (WPTC), 2015 IEEE*, 2015, pp. 1-3.
- [49] J. C. Quinn, B. J. Limb, Z. Pantic, P. Barr, R. Zane, and T. H. Bradley, "Feasibility of wireless power transfer for electrification of transportation: Techno-economics and life cycle assessment," in *Technologies for Sustainability (SusTech), 2015 IEEE Conference on*, 2015, pp. 245-249.
- [50] B. J. Limb, R. Zane, J. C. Quinn, and T. H. Bradley, "Infrastructure optimization and economic feasibility of in-motion wireless power transfer," in *2016 IEEE Transportation Electrification Conference and Expo (ITEC)*, 2016, pp. 1-4.
- [51] D. Nicolaides and J. Miles, "Wireless electric charge-on-the-move: An economic appraisal of the potential for the uk transport application."
- [52] B. J. Limb, B. Crabb, R. Zane, J. C. Quinn, and T. H. Bradley, "Economic feasibility and infrastructure optimization of in-motion charging of electric vehicles using wireless power transfer," in *IEEE PELS Workshop on Emerging Technologies: Wireless Power (2016 WoW)*, 2016, pp. 1-5.
- [53] M. Fuller, "Wireless charging in california: Range, recharge, and vehicle electrification," *Transportation Research Part C: Emerging Technologies*, vol. 67, pp. 343-356, 2016.

- [54] Office of Highway Policy Information. (2014). Annual vehicle distance traveled in miles and related data - 2014. Transportation. [Online].
- [55] U.S. Department of Energy. (2014). Supertruck making leaps in fuel efficiency. O. o. E. E. R. Energy. [Online].
- [56] Argonne National Laboratory. Downloadable dynamometer database [Online].
- [57] National Renewable Energy Laboratory. Transportation secure data center [Online].
- [58] Maxwell, "Dataset: 48 v modules," ed. Web.
- [59] Sunvault Energy Inc., "Sunvault energy and edison power company create massive 10,000 farad graphene supercapacitor," Web, 2015.
- [60] A. Sakti, J. J. Michalek, E. R. Fuchs, and J. F. Whitacre, "A techno-economic analysis and optimization of li-ion batteries for light-duty passenger vehicle electrification," *Journal of Power Sources*, vol. 273, pp. 966-980, 2015.
- [61] WiTricity, "Wit-3300 resonator pair r2.3," ed. Web.
- [62] P. Weissler, "Leaf to be sold with battery pack at c-segment price," *Web log post. SAE International. Society of Automotive Engineers*, vol. 11, 2010.
- [63] Nissan, "2011 leaf first responder's guide," ed.
- [64] J. O'Dell, "Nissan prices leaf battery replacement at \$5,500," in *Edmunds*, ed. Web, 2014.
- [65] U.S. Energy Information Administration. (2016). Short-term energy outlook: November 2016. Department of Energy. [Online].
- [66] U.S. Energy Information Administration. (2016). Annual energy outlook 2016 with projections to 2040. Department of Energy. [Online].

- [67] B. Robinson;, "New-car transaction prices increase nearly 3 percent year-over-year in september 2016, according to Kelley Blue Book," KBB, Irvine, CA, 2016.
- [68] Office of Highway Policy Information. (2014). Functional system travel - 2014. Transportation. [Online].
- [69] Office of Energy Efficiency & Renewable Energy, "Plug-in electric vehicle penetration by state, 2014," 2014.
- [70] Office of Highway Policy Information. (2014). Public road length - 2014: Miles by type of surface and ownership/functional system national summary. Transportation. [Online].
- [71] U.S. Department of Transportation, "Highway functional classification concepts, criteria and procedures," 2013.
- [72] U.S. Census Bureau, "Maf/tiger feature class code definitions," 2016.
- [73] American Road & Transportation Builders Association, "How much new road capacity do we build every year in the U.S.?", 2016.
- [74] M. Spector, J. Bennett, and J. D. Stoll, "U.S. Car sales set record in 2015," in *The Wall Street Journal*, ed. Web, 2015.
- [75] Bureau of Transportation Statistics. (2014). Number of U.S. Aircraft, vehicles, vessels, and other conveyances. Transportation. [Online].
- [76] Argonne National Laboratory. Greet 2016 [Online]. Available: <https://greet.es.anl.gov/>
- [77] M. M. Thackeray, C. Wolverton, and E. D. Isaacs, "Electrical energy storage for transportation—approaching the limits of, and going beyond, lithium-ion batteries," *Energy & Environmental Science*, vol. 5, pp. 7854-7863, 2012.

- [78] O. Egbue and S. Long, "Barriers to widespread adoption of electric vehicles: An analysis of consumer attitudes and perceptions," *Energy policy*, vol. 48, pp. 717-729, 2012.
- [79] *Chevy bolt production confirmed for 2016*, 2015.
- [80] G. Offer, D. Howey, M. Contestabile, R. Clague, and N. Brandon, "Comparative analysis of battery electric, hydrogen fuel cell and hybrid vehicles in a future sustainable road transport system," *Energy policy*, vol. 38, pp. 24-29, 2010.
- [81] T. R. Hawkins, B. Singh, G. Majeau-Bettez, and A. H. Strømman, "Comparative environmental life cycle assessment of conventional and electric vehicles," *J Ind Ecol*, vol. 17, pp. 53-64, 2013.

## APPENDICES



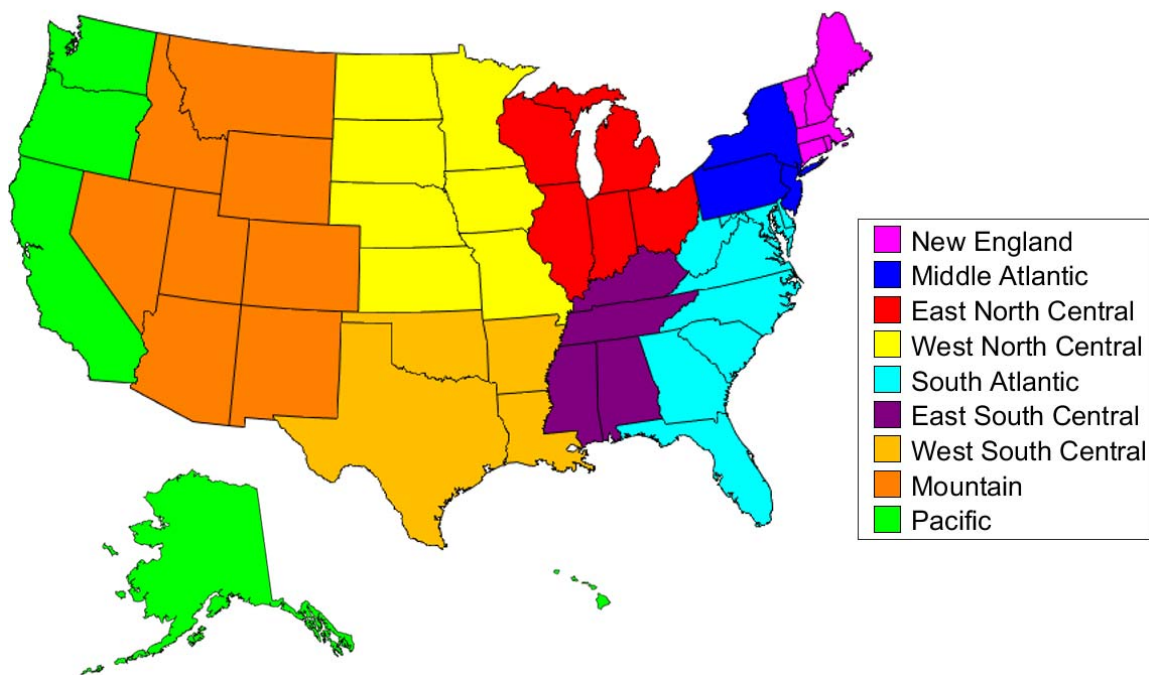

Figure 16. Electricity costs associated with each state in the United States.

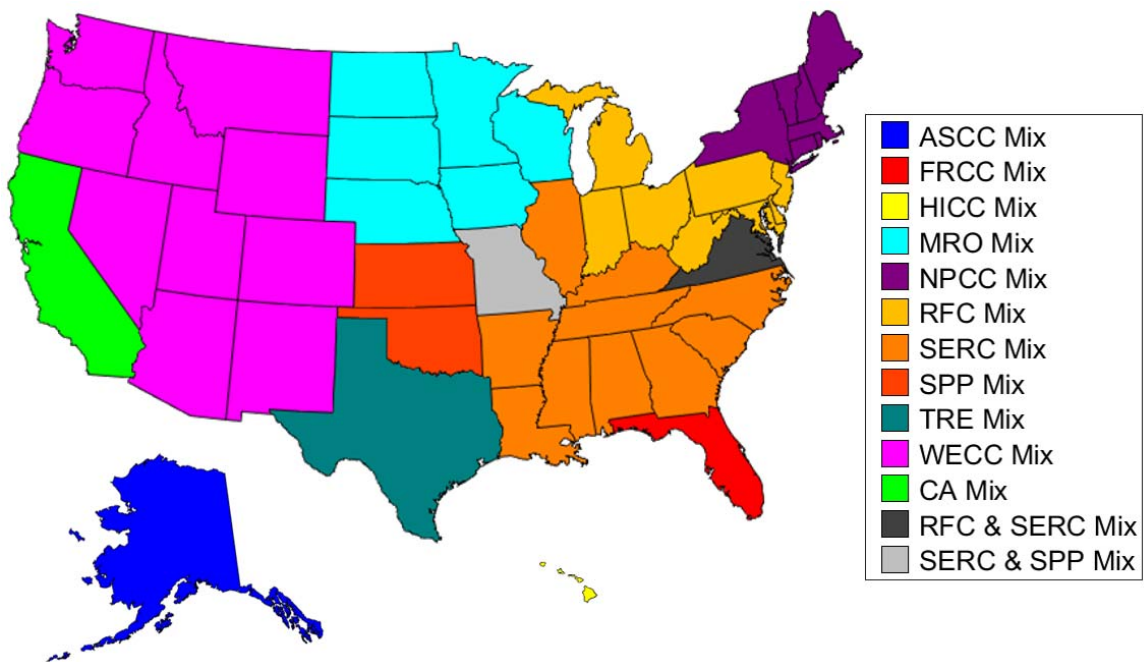

Figure 17. Electricity emissions associated with each state in the United States.



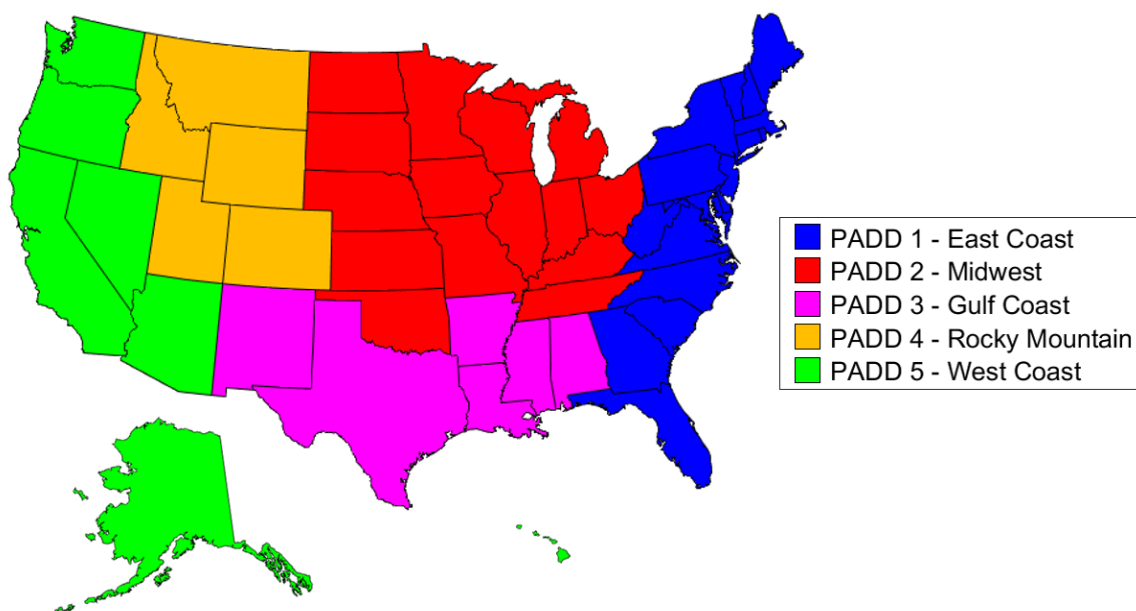

Figure 18. Gasoline costs associated with each state in the United States.

## CURRICULUM VITAE

Braden Jeffery Limb  
(December 2016)

**EDUCATION:****Masters of Science, Mechanical Engineering**

Utah State University, Logan, Utah, December 2016

Research: Techno-Economic Assessment, Lifecycle Analysis, and Optimization of Roadway Electrification Integrating Wireless Power Transfer

4.000 GPA

**Bachelor of Science, Mechanical Engineering (Summa Cum Laude)**

Utah State University, Logan, Utah, May 2015

Minor in Mathematics

3.959 GPA

**PROFESSIONAL & RESEARCH EXPERIENCE:****Graduate Research Assistant (January 2015 – Present)**

Department of Mechanical and Aerospace Engineering, Utah State University

Academic Advisors: Jason C. Quinn (ME), Regan Zane (EE), Robert Spall (MAE)

**Governor's Energy Leadership Scholar (October 2015 – September 2016)**

Utah Energy Research Triangle, Utah

**Research Assistant (May 2015 – June 2015)**

Department of Mechanical Engineering, Colorado State University

Advisor: Dr. Thomas Bradley (ME)

**Associate Engineering Intern (May 2014 – August 2014)**

Questar Gas Company, Salt Lake City, UT

**JOURNAL PUBLICATIONS:**

1. **B. J. Limb**, T. H. Bradley, B. Crabb, R. Zane, and J. C. Quinn, *Techno-Economic Assessment and Systems Optimization of Dynamic Charging of Electric Vehicles Integrating Wireless Power Transfer*, IEEE Transactions On Transportation Electrification, Winter 2016 (In Preparation)
2. **B. J. Limb**, D. G. Work, J. Hodson, and B. L. Smith, *The Efficacy of Chauvenet's Criterion*, Journal of Fluids Engineering, Fall 2016 (In Review)
3. **B. J. Limb**, T. H. Bradley, R. Zane, and J. C. Quinn, *Economic Feasibility of Transportation Electrification Integrating Wireless Power Transfer*, Proceedings of the Institution of Mechanical Engineers, Part D: Journal of Automobile Engineering, Autumn 2016 (In Review)

**FULL CONFERENCE PUBLICATIONS:**

1. **B. J. Limb**, T. H. Bradley, B. Crabb, R. Zane, C. McGinty, J. C. Quinn, *Economic and Environmental Feasibility, Architecture Optimization, and Grid Impact of Dynamic Charging of Electric Vehicles using Wireless Power Transfer*, The 6<sup>th</sup> Hybrid and Electric Vehicle Conference, London, UK, November 2016
2. **B. J. Limb**, T. H. Bradley, B. Crabb, R. Zane, J. C. Quinn, *Economic Feasibility and Infrastructure Optimization of In-Motion Charging of Electric Vehicles Using Wireless Power Transfer*, IEEE PELS Workshop on Emerging Technologies: Wireless Power Transfer (2016 WoW), Knoxville, TN, USA, October 2016
3. **B. J. Limb**, T. H. Bradley, R. Zane, J. C. Quinn, *Infrastructure Optimization and Economic Feasibility of In-Motion Wireless Power Transfer*, 2016 IEEE Transportation Electrification Conference, Dearborn, MI, USA, June 2016
4. J. C. Quinn, **B. J. Limb**, Z. Pantic, P. Barr, R. Zane, T. H. Bradley, *Feasibility of Wireless Power Transfer for Electrification of Transportation: Techno-economics and Life Cycle Assessment*, SusTech| 2015 - IEEE Conference on Technologies for Sustainability, Ogden, UT, USA, July 2015
5. J. C. Quinn, **B. J. Limb**, Z. Pantic, P. Barr, R. Zane, *Techno-Economic Feasibly and Environmental Impact of Wireless Power Transfer Roadway Electrification*, IEEE Wireless Power Transfer Conference 2015, Boulder, CO, USA, May 2015

**AWARDED GRANTS:**

1. **B. J. Limb**, J. C. Quinn, *Environmental Impact, Economic Feasibility, and Optimization of Transportation Electrification Integrating Wireless Power Transfer*, Governor's Energy Leadership Scholars Program, Utah's 10-Year Strategic Energy Plan, UT, USA, August 2015

**CONFERENCE ORAL PRESENTATIONS:**

1. **B. J. Limb**, T. H. Bradley, B. Crabb, R. Zane, C. McGinty, J. C. Quinn, *Economic and Environmental Feasibility, Architecture Optimization, and Grid Impact of Dynamic Charging of Electric Vehicles using Wireless Power Transfer*, The 6<sup>th</sup> Hybrid and Electric Vehicle Conference, London, UK, November 2016
2. **B. J. Limb**, T. H. Bradley, B. Crabb, R. Zane, J. C. Quinn, *Economic Feasibility and Infrastructure Optimization of In-Motion Charging of Electric Vehicles Using Wireless Power Transfer*, IEEE PELS Workshop on Emerging Technologies: Wireless Power Transfer (2016 WoW), Knoxville, TN, USA, October 2016
3. **B. J. Limb**, T. H. Bradley, R. Zane, J. C. Quinn, *Infrastructure Optimization and Economic Feasibility of In-Motion Wireless Power Transfer*, 2016 IEEE Transportation Electrification Conference, Dearborn, MI, USA, June 2016
4. **B. J. Limb**, *Electric Highways*, ideacity| 2016, Toronto, ON, Canada, June 2016  
<http://www.ideacity.ca/video/braden-limb-electric-highways/>
5. **B. J. Limb**, *The Electric Vehicle Revolution*, 2016 Student Research Symposium, Logan, UT, USA, April 2016
6. J. C. Quinn, **B. J. Limb**, Z. Pantic, P. Barr, R. Zane, *Feasibility of Wireless Power Transfer for Electrification of Transportation: Techno-economics and Life Cycle Assessment*, SusTech 2015 - IEEE Conference on Technologies for Sustainability, Ogden, UT, USA, August 2015
7. J. C. Quinn, **B. J. Limb**, Z. Pantic, P. Barr, R. Zane, *Techno-Economic Feasibility and Environmental Impact of Wireless Power Transfer Roadway Electrification*, IEEE Wireless Power Transfer Conference 2015, Boulder, CO, USA, May 2015

**CONFERENCE POSTER PRESENTATIONS:**

1. **B. J. Limb**, T. H. Bradley, B. Crabb, R. Zane, J. C. Quinn, *Technology Optimization and Feasibility of In-Motion Charging of Electric Vehicles*, SELECT Annual Meeting and Technology Showcase, Logan, UT, USA, September 2016
2. **B. J. Limb**, J. C. Quinn, *Electrification of Transportation Integrating Wireless Power Transfer: Economic Feasibility, Environmental Assessment, and Infrastructure Optimization*, 2016 Governor's Energy Development Summit, Salt Lake City, UT, USA, May 2016
3. **B. J. Limb**, T. H. Bradley, R. Zane, J. C. Quinn, *Economic Feasibility, Vehicle Optimization, and Vehicle-to-Grid Assessment of Roadway Electrification*, Conference on Electric Roads and Vehicles, Logan, UT, USA, May 2016
4. **B. J. Limb**, T. H. Bradley, P. Barr, R. Zane, J. C. Quinn, *Techno-Economic and Life Cycle Assessment of Wireless Power Transfer Roadway Electrification*, 2015 USTAR Confluence: Where Innovative Ideas Seed, Grow and Thrive, Salt Lake City, UT, USA, September 2015

**AWARDS:**

- 2016 Excellent Communicator Award, Student Research Symposium, Utah State University
- 2015 Bill E. Robins Memorial Award Finalist, Utah State University  
<http://www.usu.edu/ususa/robinsawards/nominate.cfm>
- 2015 Academic Excellence Award – Senior, Mechanical and Aerospace Engineering Department, Utah State University
- 2014 Academic Excellence Award – Junior, Mechanical and Aerospace Engineering Department, Utah State University
- 2013 Academic Excellence Award – Pre-Professional, Mechanical and Aerospace Engineering Department, Utah State University

**MEDIA ATTENTION:**

1. Wheels.ca Interview, August 29<sup>th</sup>, 2016  
<http://www.wheels.ca/news/the-future-of-driving-its-electrifying/>
2. Metro Morning Interview, CBC Radio, June 15<sup>th</sup>, 2016  
<http://www.cbc.ca/news/canada/toronto/programs/metromorning/electrified-roads-1.3636067>
3. The Utah Statesman Article, February 2<sup>nd</sup>, 2016  
<http://usustatesman.com/electrified-transportation-on-the-horizon-at-utah-state/>
4. IEEE USA InSight Article on SusTech 2015, September 19<sup>th</sup>, 2015  
<http://insight.ieeeusa.org/insight/content/ieeusa/177246>