

SmallSat 2016 CubeSat Pre-Conference Workshop:

Near Earth Asteroid (NEA) Scout Solar Sail Implementation

Vinh Bach²

Alex Few¹

Duy Nguyen²

Jay Warren³

Chris Becker¹

Andrew Heaton¹

Juan Orphee¹

Jared Dervan¹

Travis Imken²

Brandon Stiltner¹

Ben Diedrich¹

Tiffany Lockett¹

Olive Stohlman³

¹NASA Marshall Space Flight Center

²Jet Propulsion Laboratory

³NASA Langley Research Center

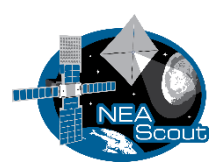

Near Earth Asteroid (NEA) Scout Overview



The Near Earth Asteroid Scout Will

- Image/characterize a NEA during a slow flyby
- Demonstrate a low cost asteroid reconnaissance capability

Key Spacecraft & Mission Parameters

- 6U cubesat (20 cm X 10 cm X 30 cm)
- ~86 m² solar sail propulsion system
- Manifested for launch on the Space Launch System (EM-1/2018)
- Up to 2.5 year mission duration
- < 1 AU maximum distance from Earth

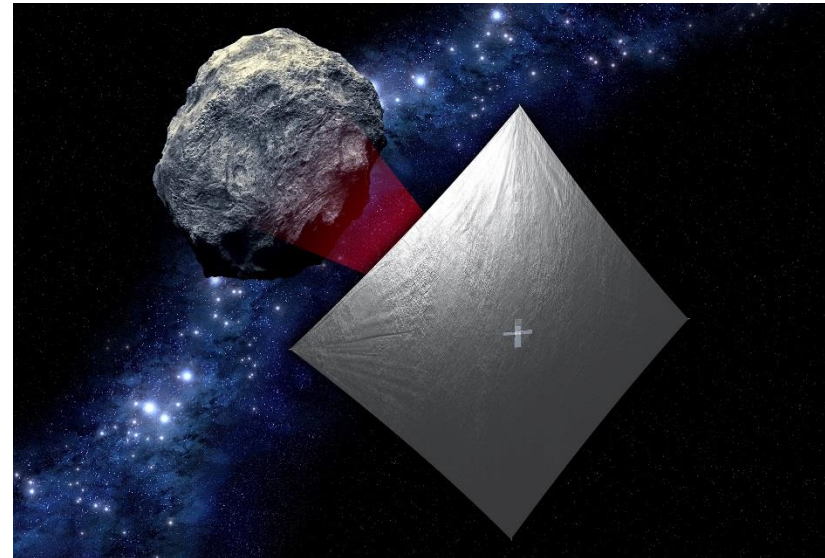

Leverages: Combined experiences of MSFC (PM, SE, Solar Sail, AMT, G&C, and Mission Operations) and JPL (Flight System Bus, Instrument, Science) with support from GSFC, JSC, and LaRC



Target Reconnaissance with medium field imaging
Shape, spin, and local environment

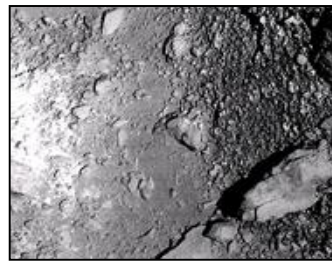

Close Proximity Imaging
Local scale morphology, terrain properties, landing site survey

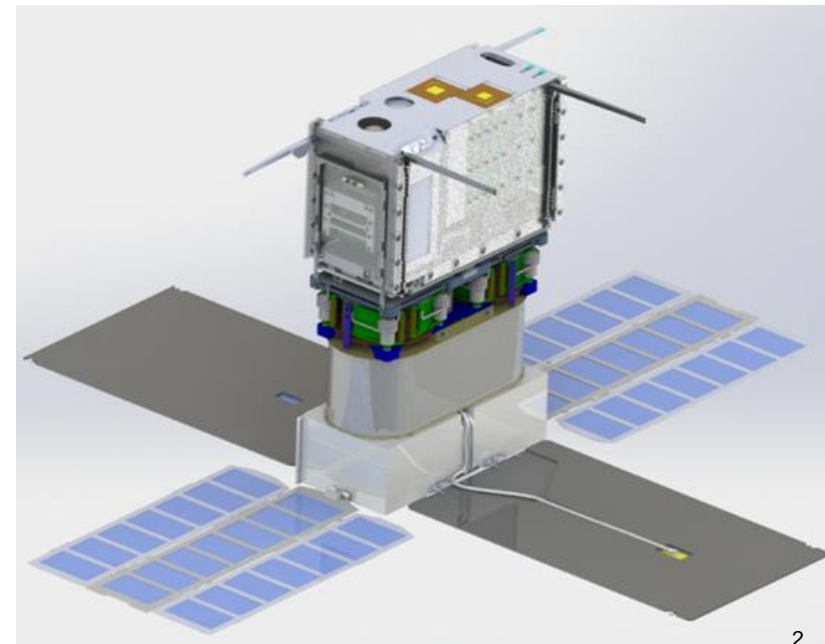

Close Proximity Science
High-resolution imaging,
10 /px GSD over >30% surface
SKGs: Local morphology
Regolith properties



JPL IntelliCam
(Updated OCO-3
Context Camera)



NEA Reconnaissance
<100 km distance at encounter
50 cm/px resolution over 80% surface
SKGs: volume, global shape, spin
properties, local environment



Target Detection and Approach:
50K km, Light source observation
SKGs: Ephemeris determination and
composition assessment (color)

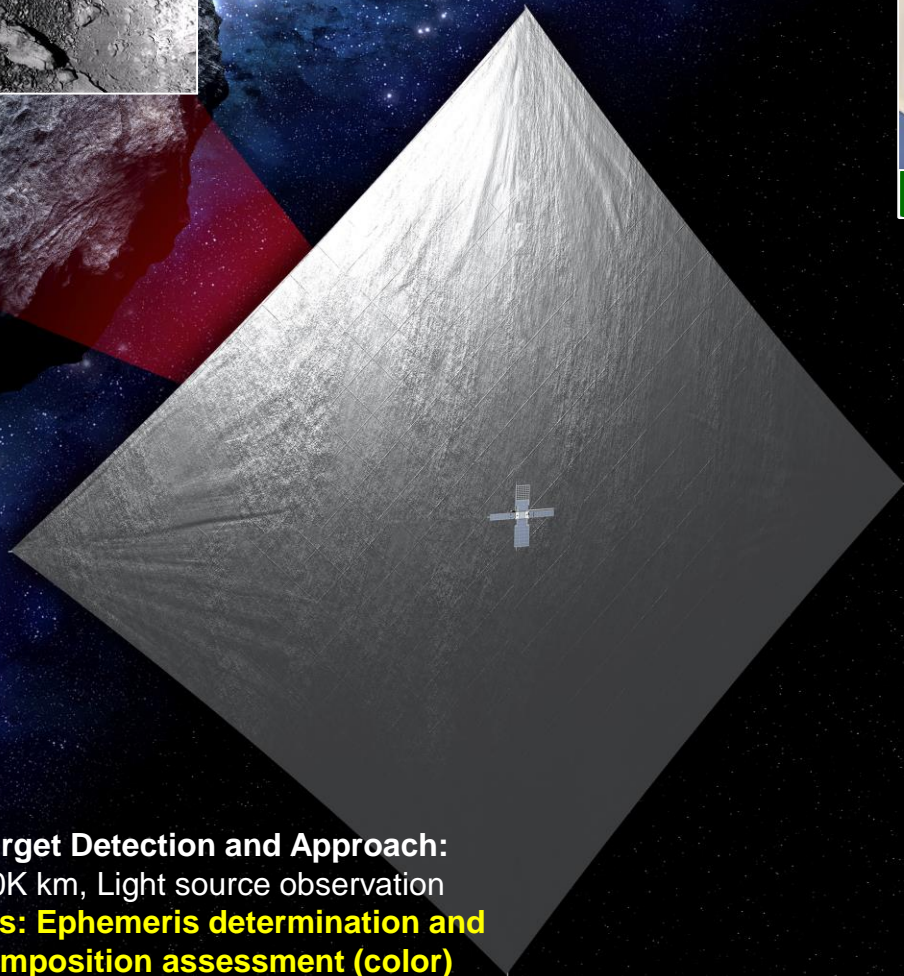

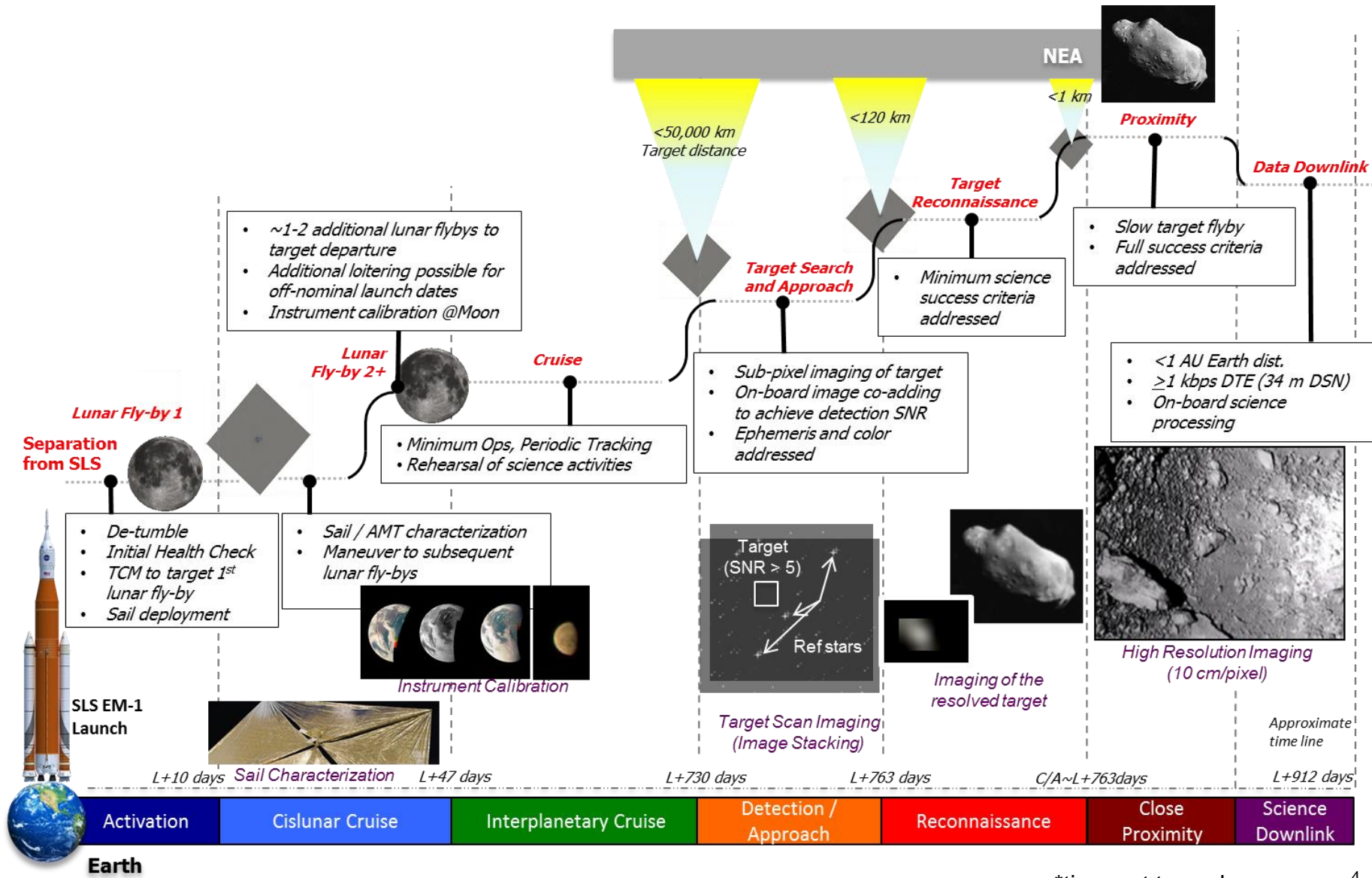

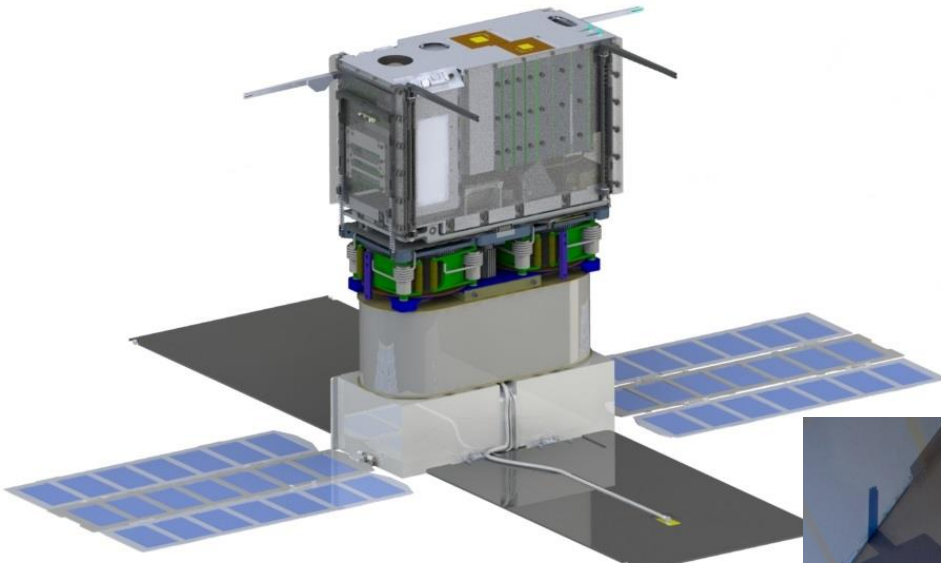

'Propellantless' primary propulsion method using momentum exchange with incident photons

Leverages MSFC NanoSail-D (2010) and collaborate arrangements with the Planetary Society and University of Surrey

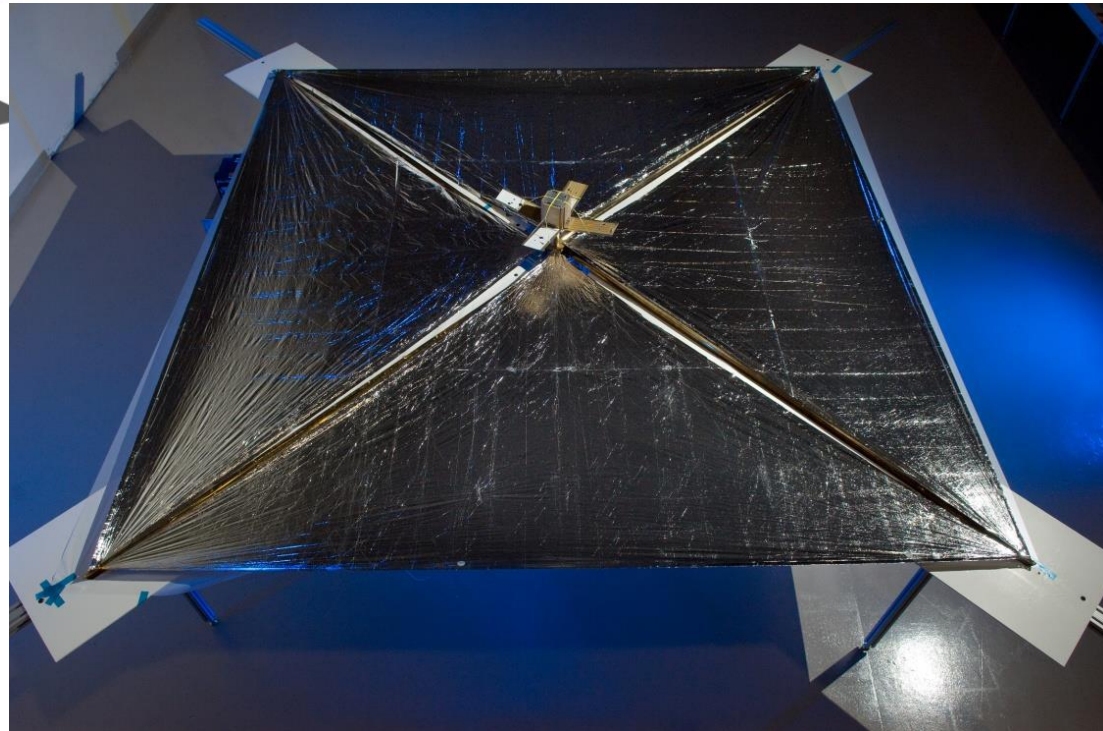
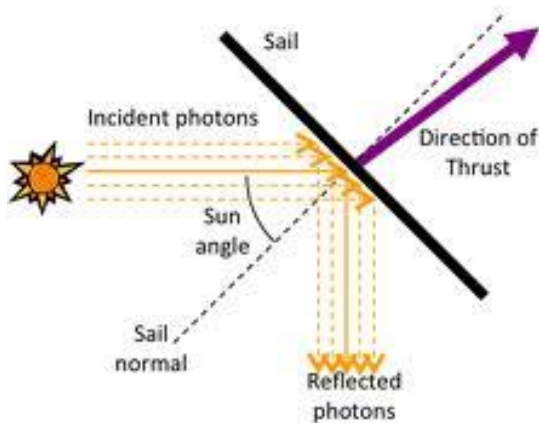

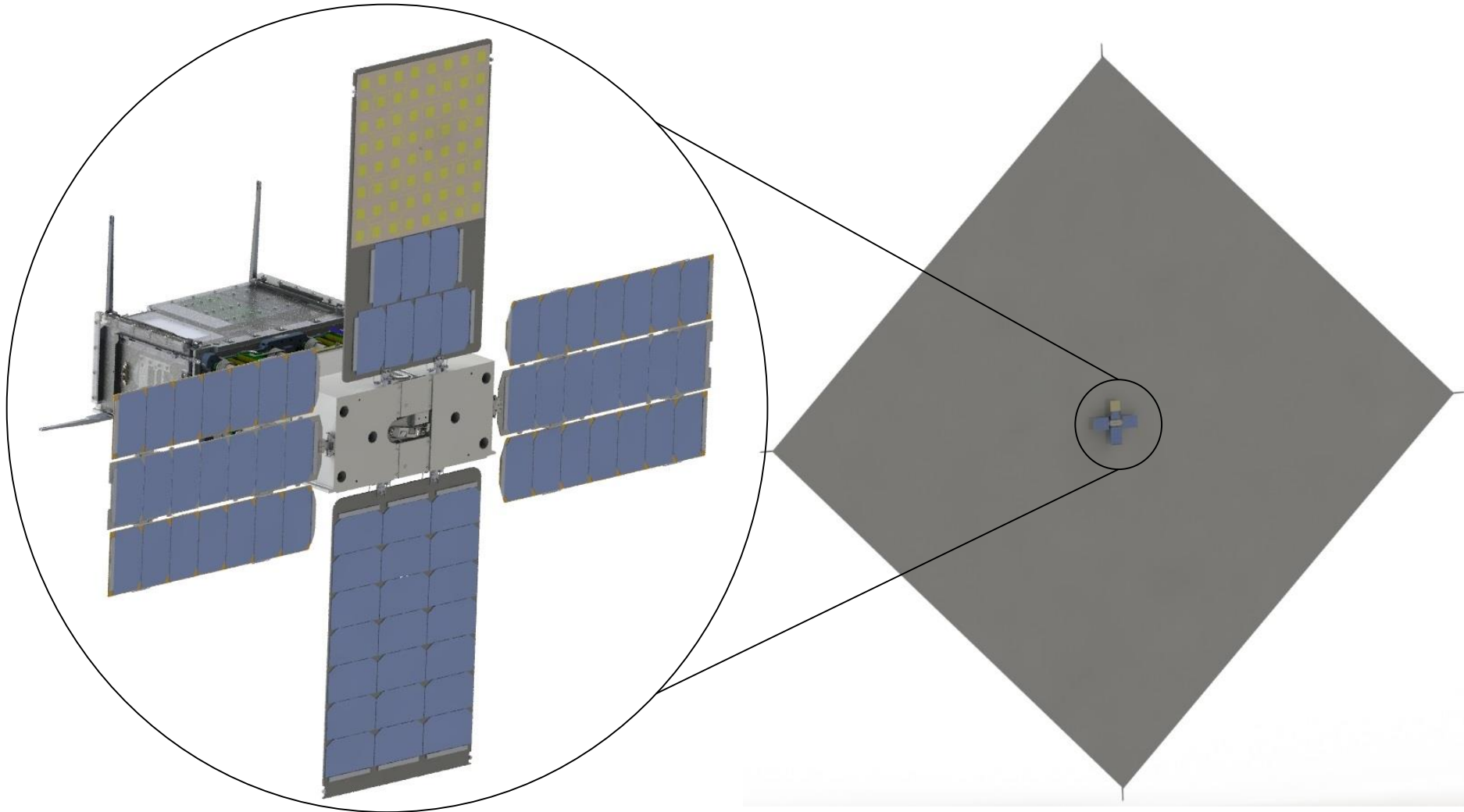

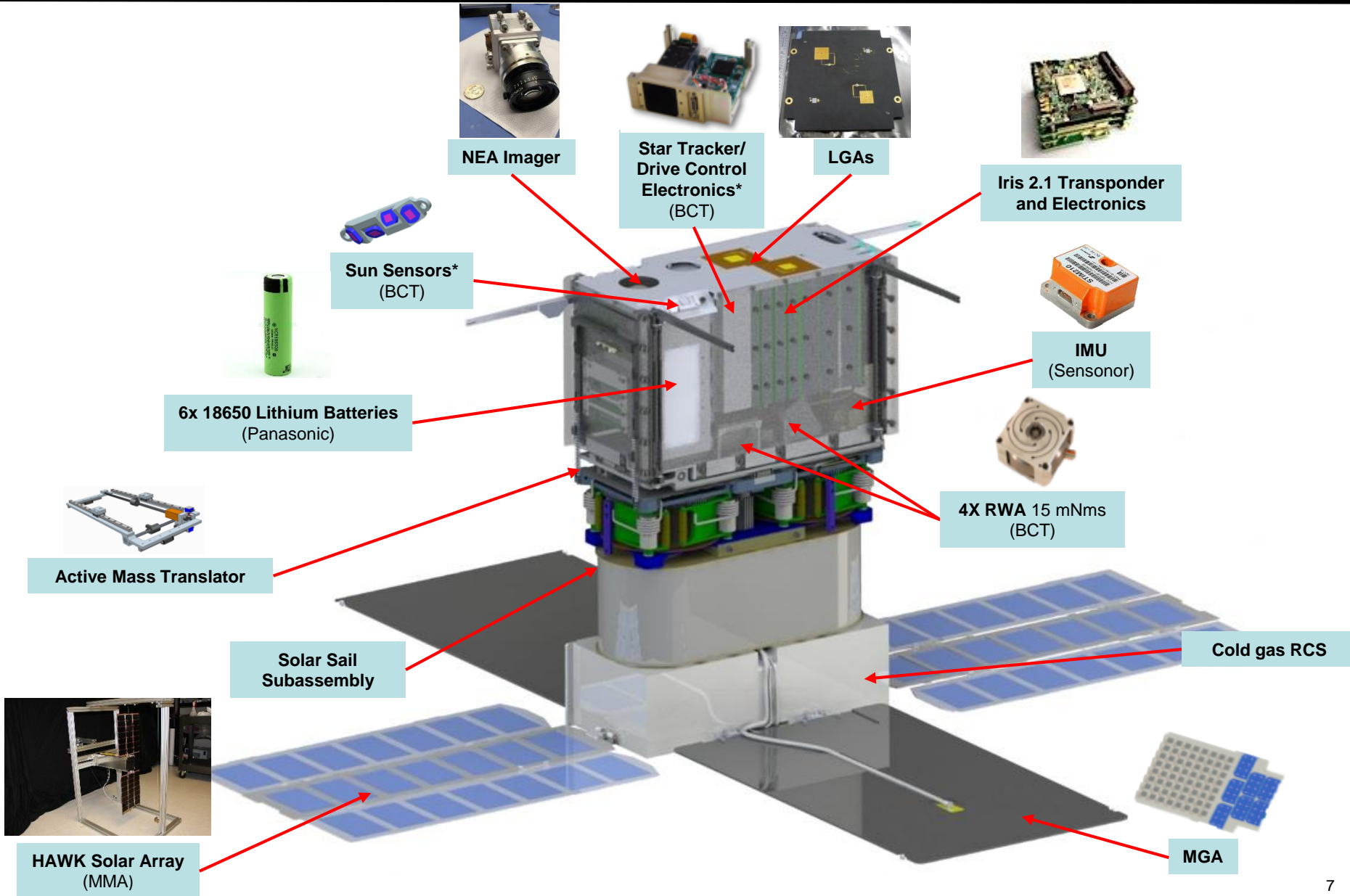

- ◆ Solar Sail transient deployment event and ground testing
- ◆ Persistent generation of strong disturbance torques with limited expendable propellant
- ◆ Need for robust ADCS to enable trajectory, Earth-pointing slews, and NEA detection/SKG science objectives
- ◆ Predictable thrust modeling

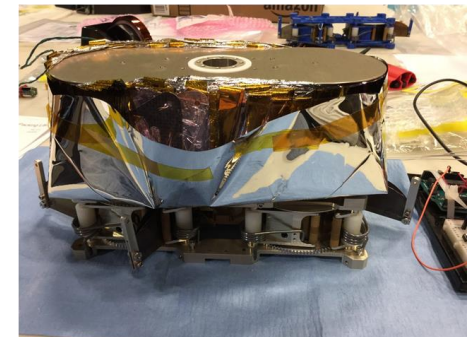
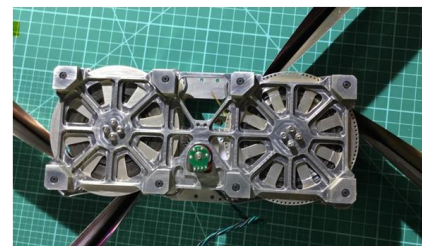
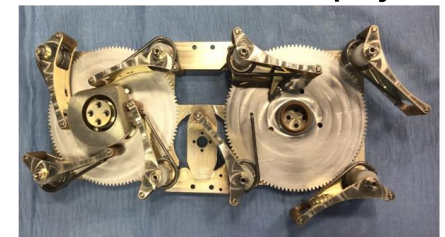
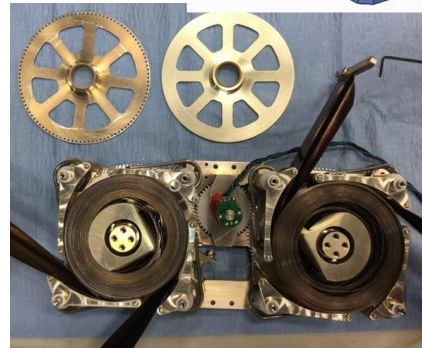
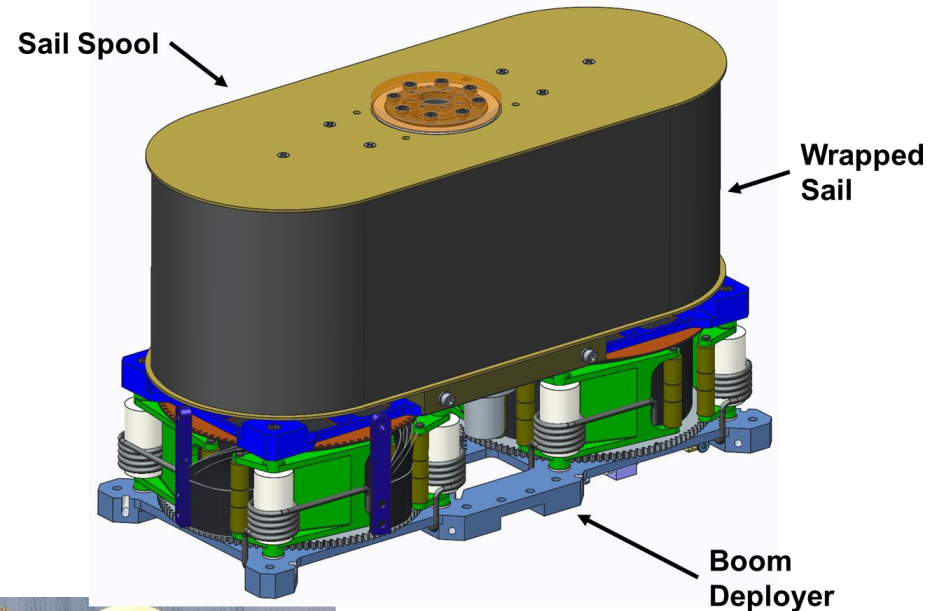

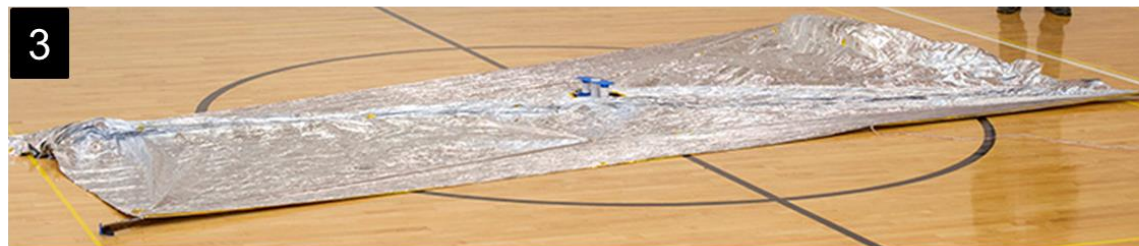

Single sail membrane drives initial 'bow tie' effect: Booms do not maintain 90deg relative orientation (less predictable induced disturbance force) and direct sunlight on booms drive significant thermal deflections

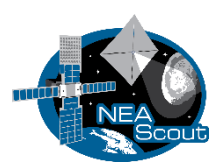

1st Full Scale Solar Sail Ground Deployment

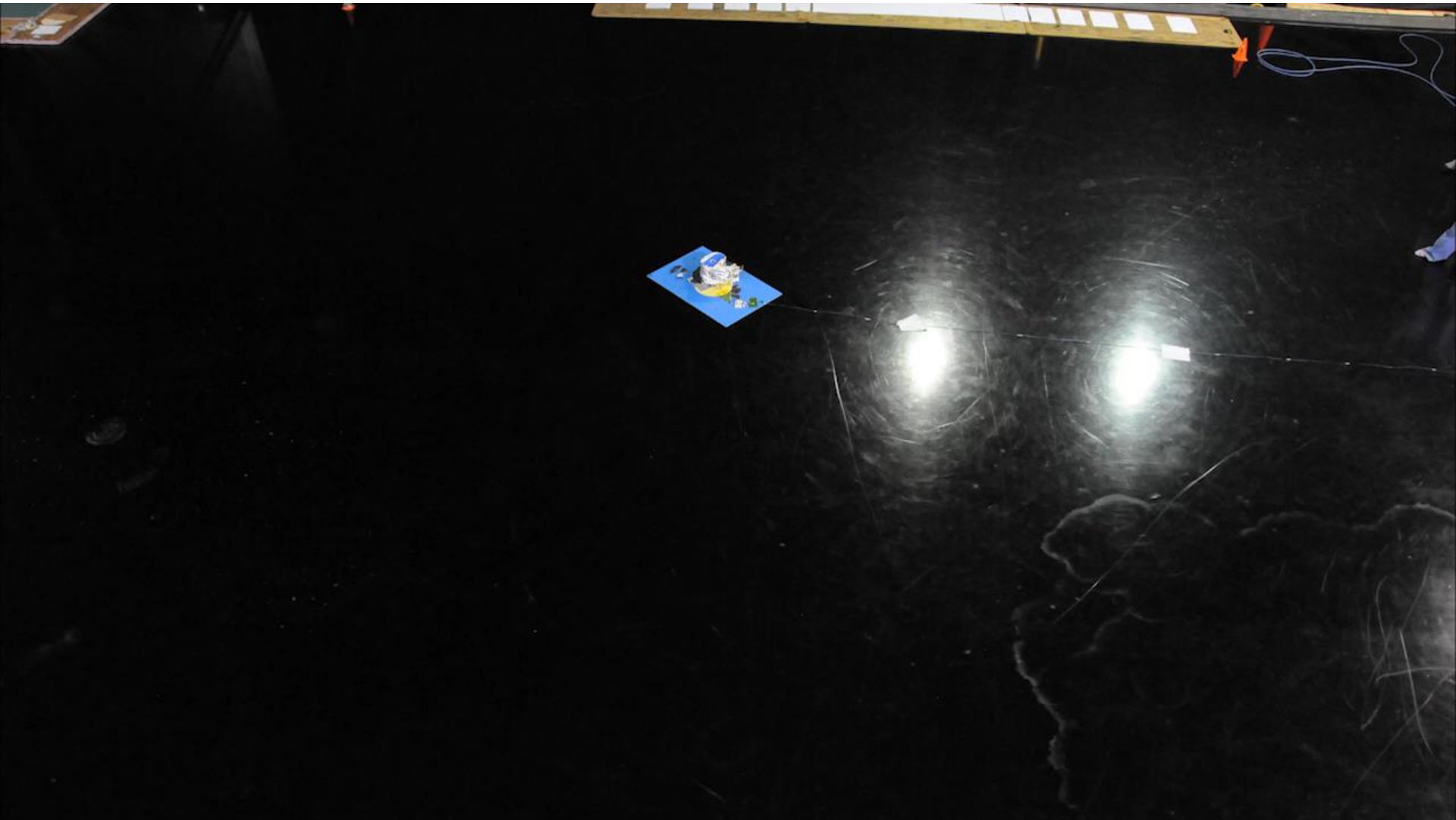

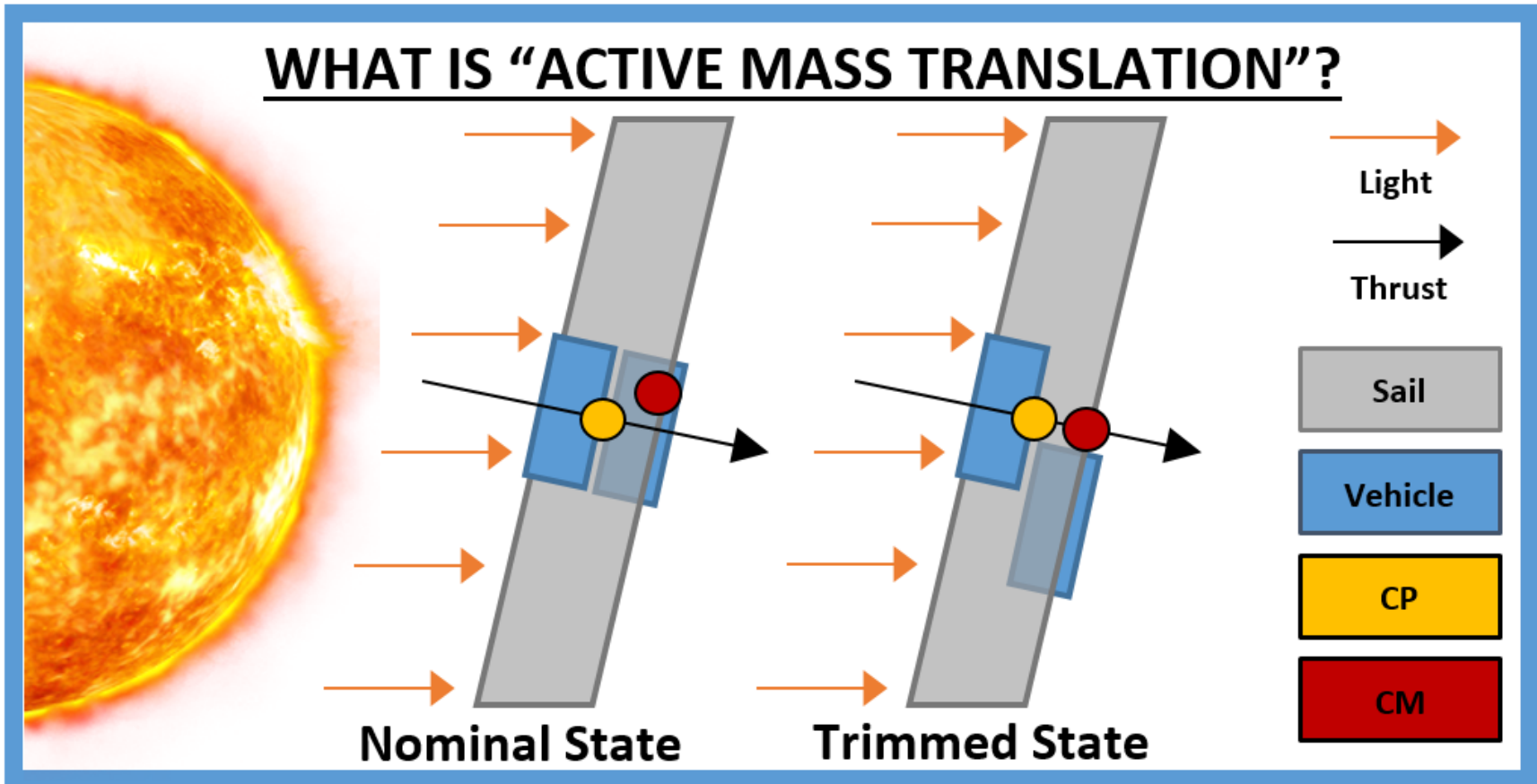

Relative adjustment of part of the spacecraft relative to the other to alter the inertial properties of the vehicle and align the Solar Sail Center-of-Pressure (CP) and Center-of-Mass (CM)

Nominal State

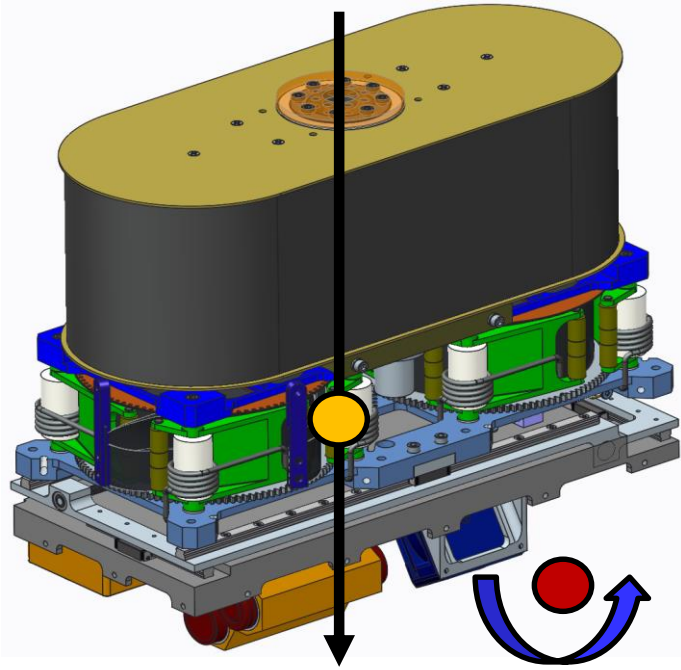

Trimmed State

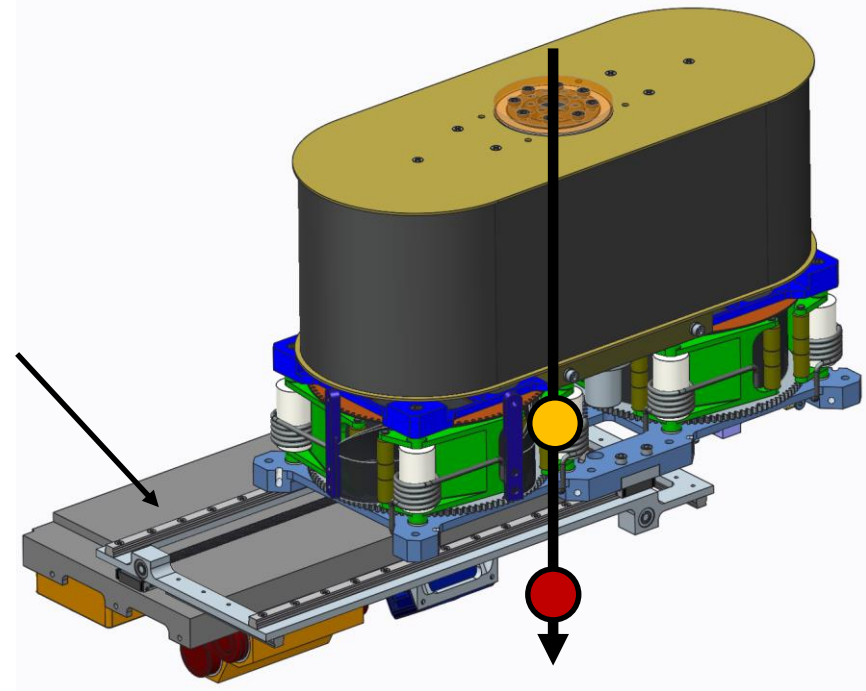

AMT

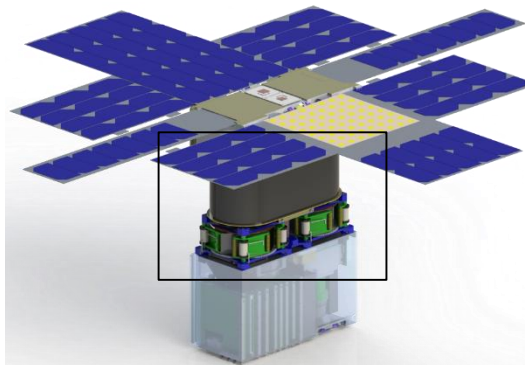
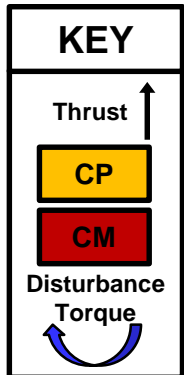

- AMT does not completely eliminate 'windmill' torque about sail normal
- Generated torque varies with roll ('clock') angle and solar angle of incidence (AOI)
- <20deg AOI, RCS must be used for Z-momentum desaturation
- >20deg AOI, clock angle can be adjusted to manage or minimize accumulation of Z-momentum
- Underscores importance of characterization period early in the mission

Z torque variation with roll angle at optimal AMT position

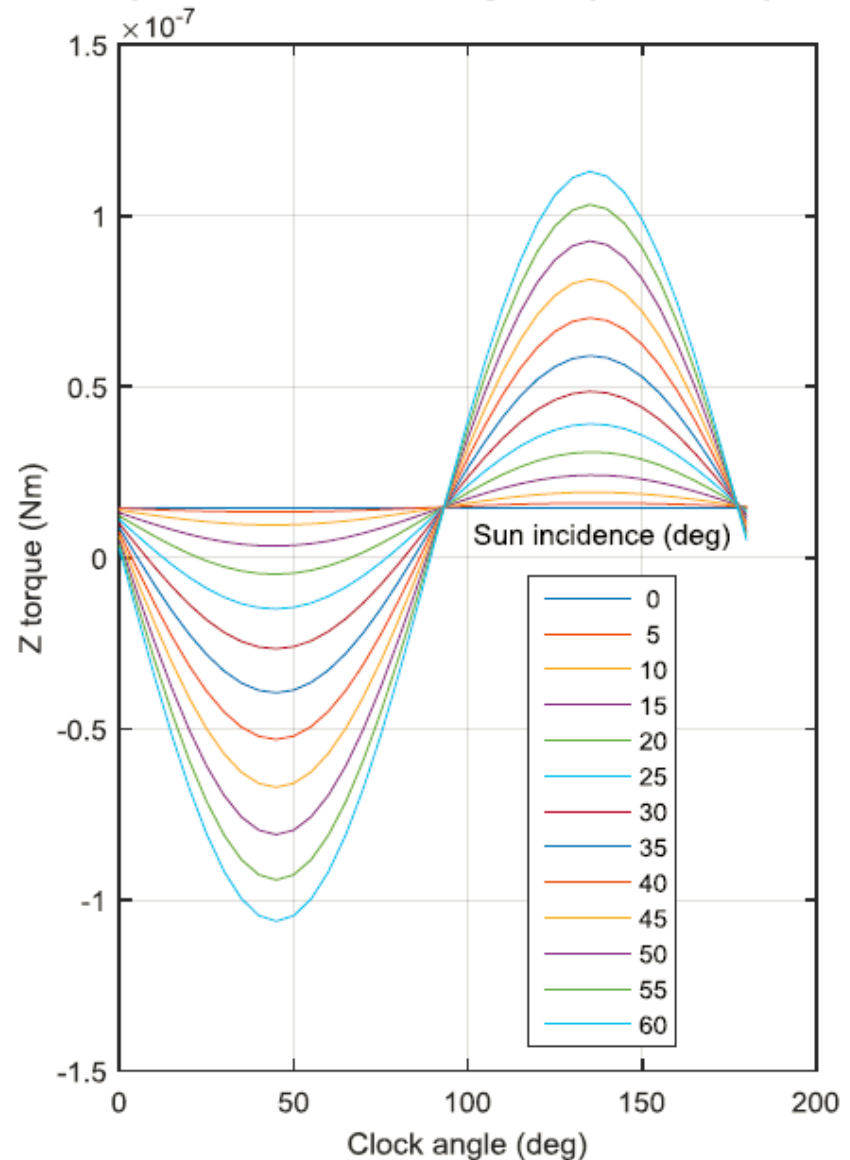

◆ Pointing Stability Requirements

- Jitter + Drift < 13 arcsec for 0.7 sec
- Jitter + Drift < 130 arcsec for 60 sec

- ◆ Drift+Jitter amplitudes: maximum control error during an exposure time Δt , during and after a slew at maximum slew rate of 0.1 deg/sec

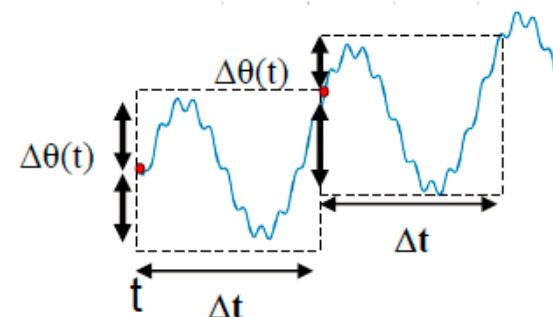

13 arcsec for 0.7 sec

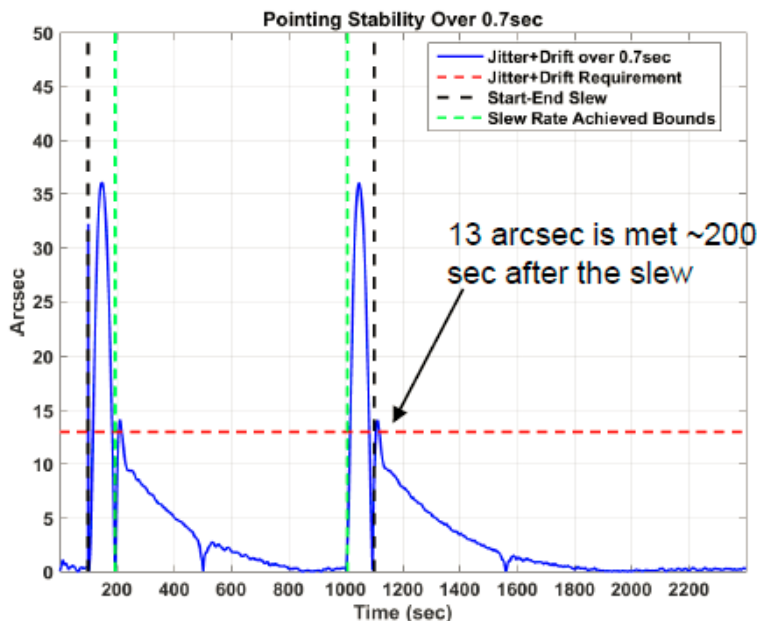

130 arcsec for 60 sec

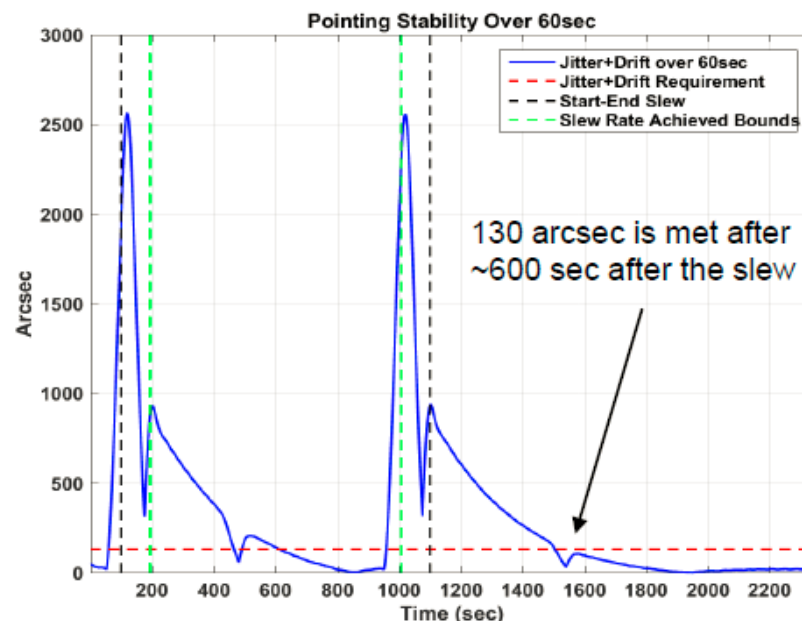

Pointing stability requirements are met after a settling time of:

- ~200 sec for 13 arcsec in 0.7 sec
- ~600 sec for 130 arcsec in 60 sec

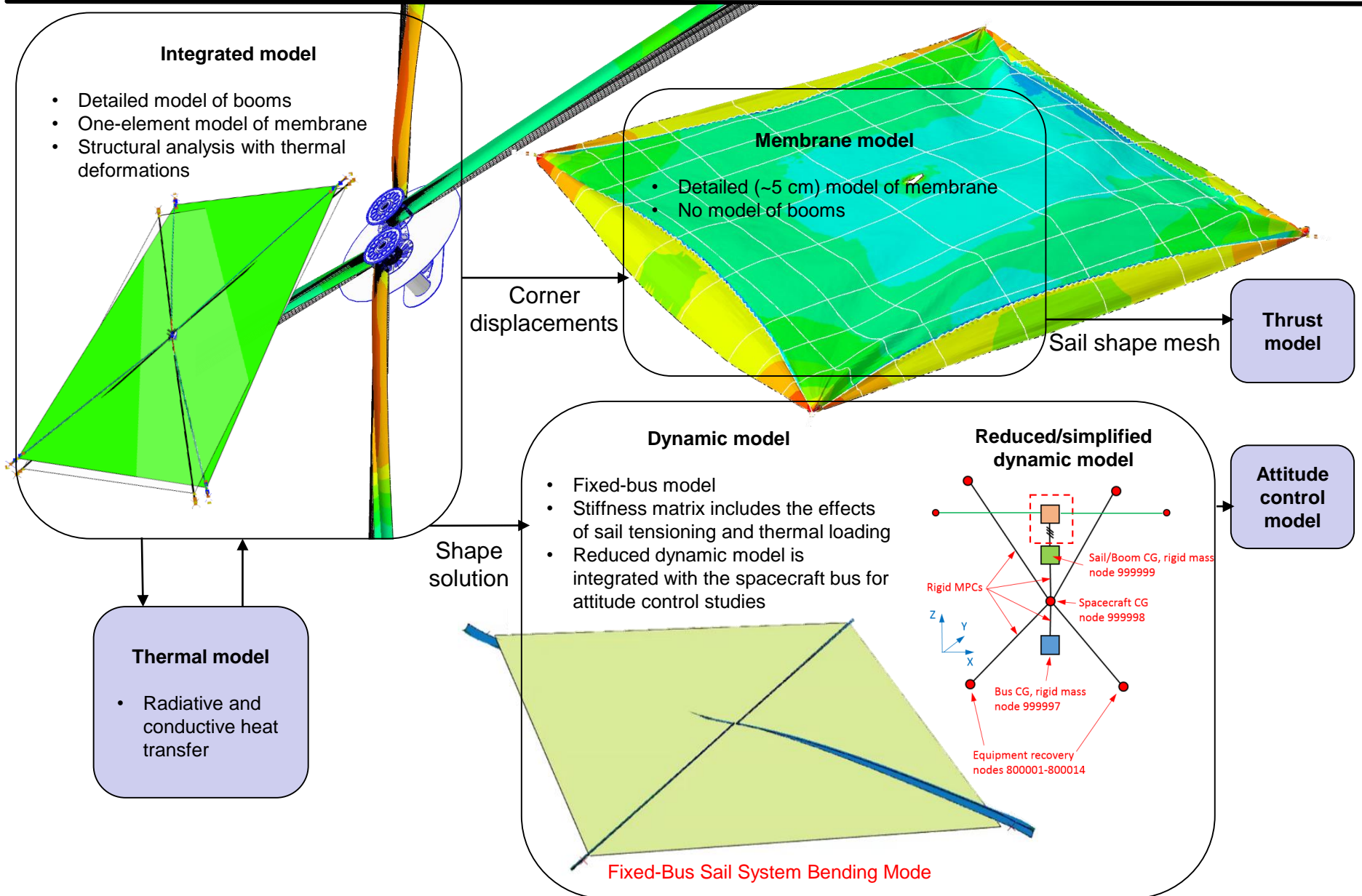

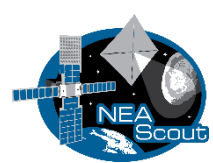

◆ Summary

- Numerous challenges exist in implementing a Solar Sail mission, particularly within a CubeSat form factor
- Extensive design, analysis, and testing has been performed to-date to address these challenges
- Difficulty in validating analytical models and performing ground (1G) demonstrations given gossamer nature of Solar Sails
- NEA Scout flight on SLS EM-1 flight opportunity (2018) will provide a giant leap forward in clarifying our understanding of Solar Sail modeling and performance

◆ Project Status

- On track for August Design Review with significant flight procurements to follow
- Flight System integration starts June 2017
- Manifested on SLS EM-1 for 2018 deep space flight opportunity
- NEA flyby anticipated in 2021

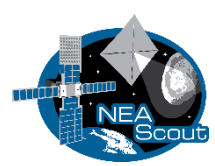

BACKUP

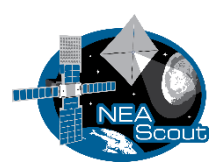

HUMAN OPERATIONS

Internal structure (regolith vs. monolith)
Sub-surface properties
General mineral, chemical composition

Internal structure (regolith vs. monolith)
Sub-surface properties (→ beta)
General mineral, chemical composition

PLANETARY DEFENSE

SCIENCE

Internal structure (regolith vs. monolith)
Sub-surface properties
Detailed mineral, chemical, isotopic composition

Detailed mineral, chemical composition

RESOURCE UTILIZATION

Intersection of All

Location (position prediction, orbit)
Size (existence of binary/ternary)
Rotation rate and pole position
Particulate environment/Debris field
Electrostatic charging and Plasma field
Thermal environment
Gravitational field structure
Mass/density estimates
Surface morphology and properties
Regolith mechanical and geotechnical properties

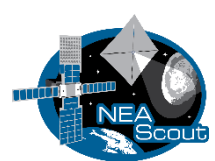

Space Launch System (SLS) Exploration Mission 1 (EM-1) Accommodation

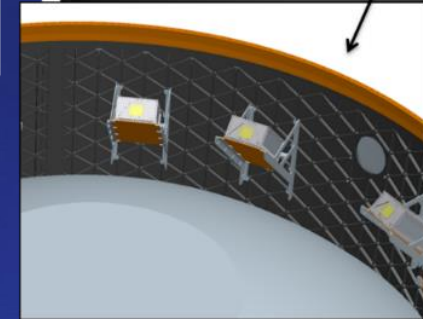
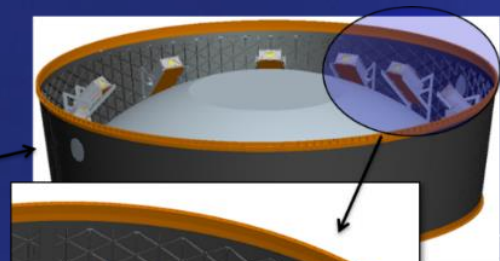
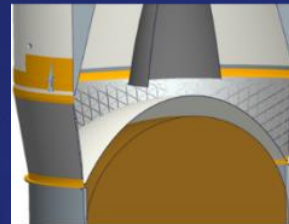
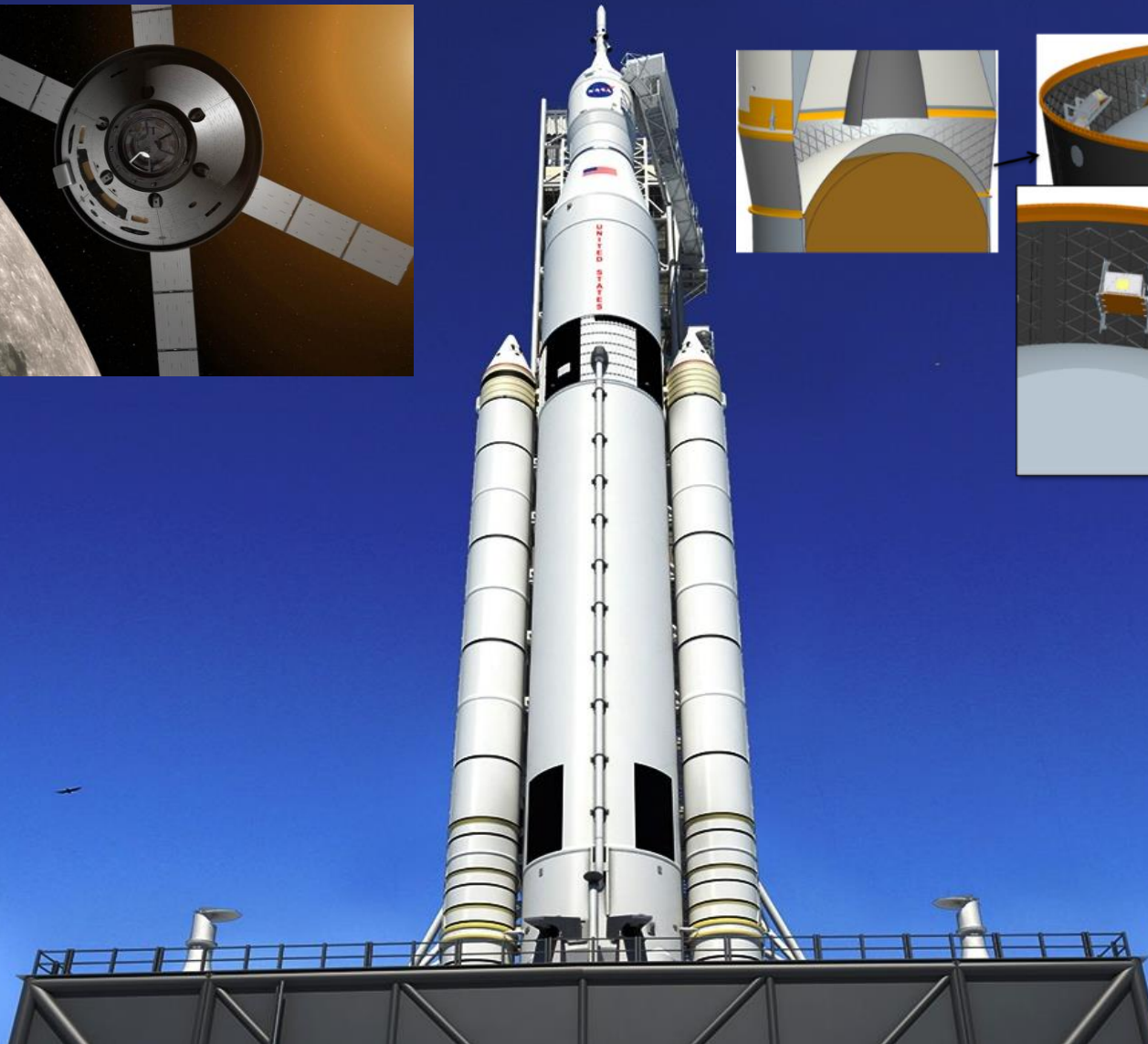
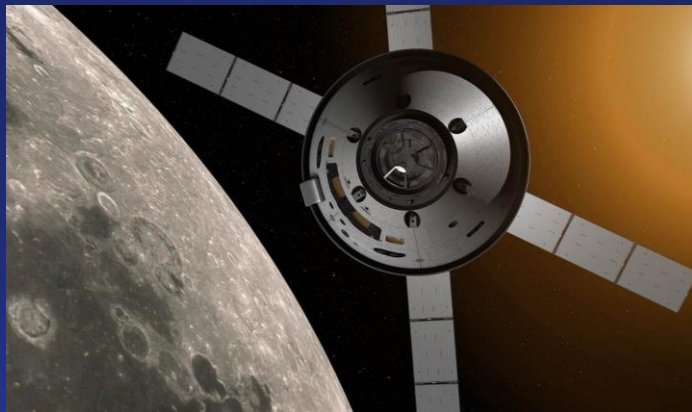

NEA Reconnaissance & Small Body Science

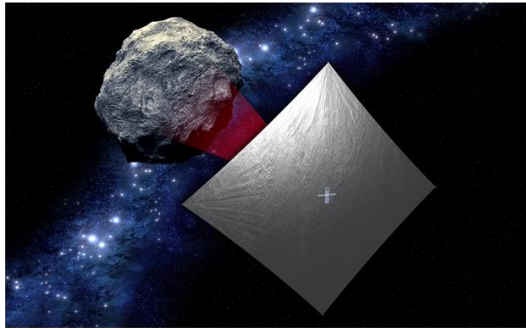

Solar & Out of the Ecliptic Science

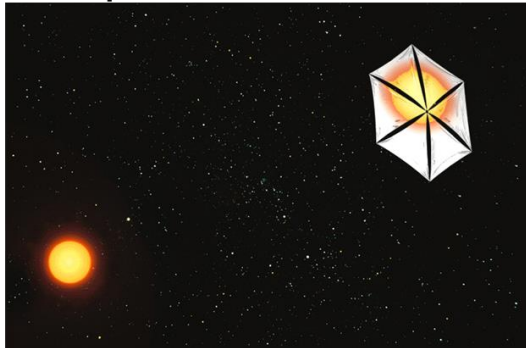

Earth Pole Sitting

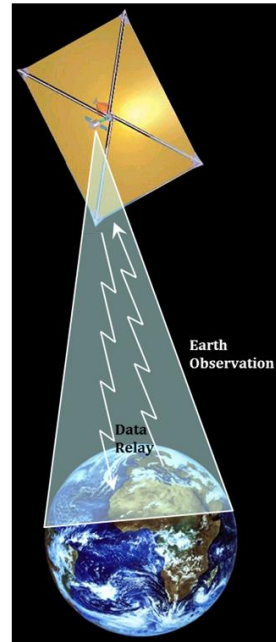

Rapid Outer Solar System Exploration and Escape

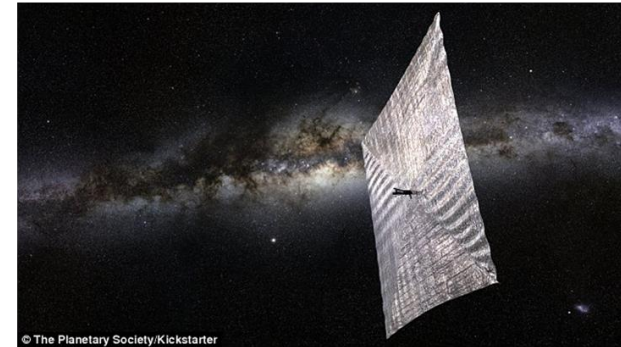

Toward Higher Performance Beamed Energy Propulsion

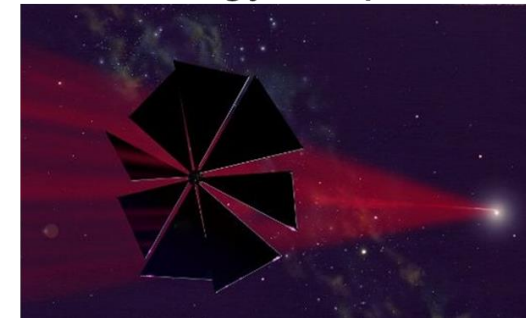

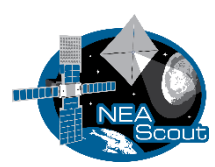

1/2 Scale Deployment



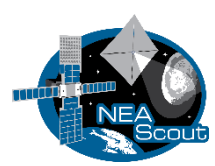

1/2 Scale Folding Video



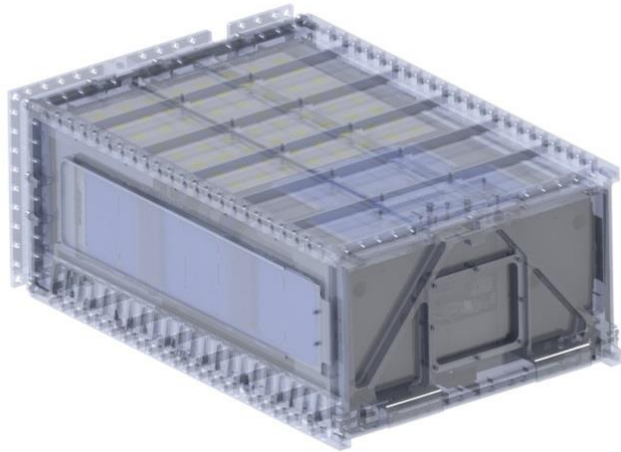

NEAS Inside PSC
6U Dispenser

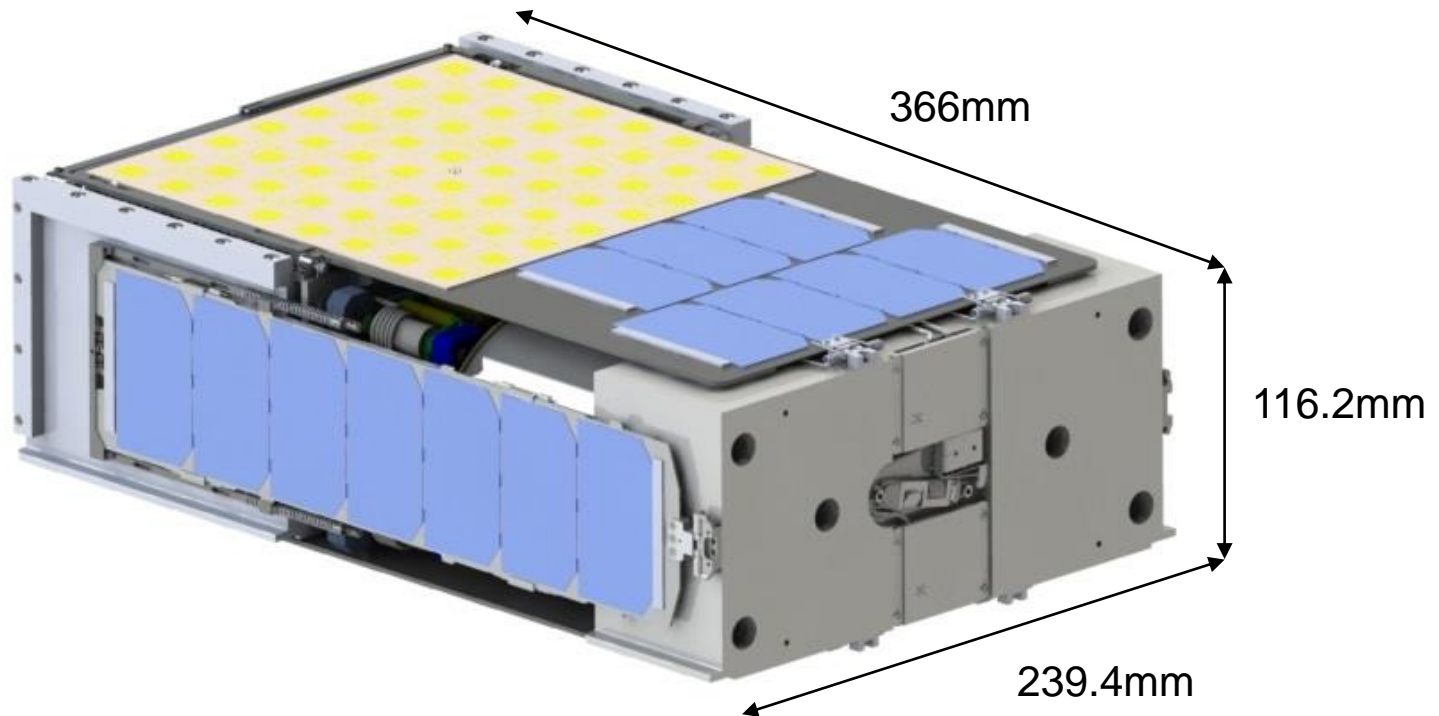

- Breadboarding hardware development as proof-of-concept
- EDU hardware in development for environmental testing and wire harness implementation

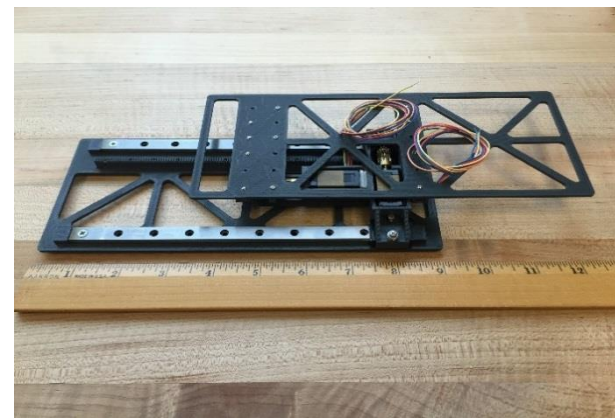
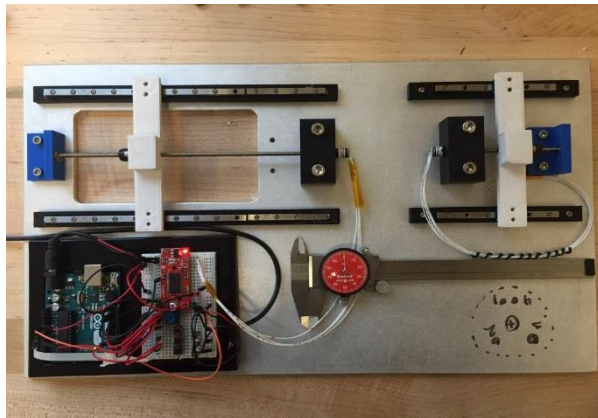
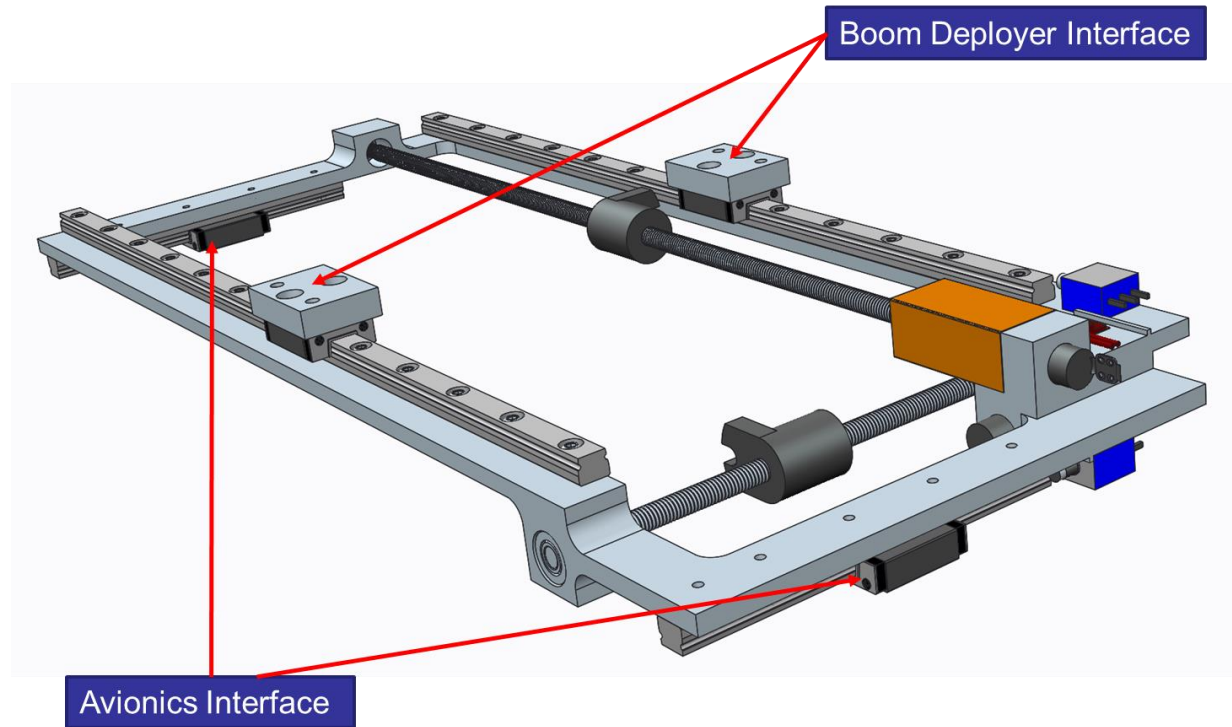

- ◆ Flat Plate optical model published in Wright and cited by McInnes
- ◆ Shows tangential and normal components
- ◆ Tangential component important to torque

P = solar pressure

A = area

\tilde{r} = total reflectivity

s = fraction of reflection that is specular

α = sun incidence angle

B_f, B_b = front and back side non-Lambertian coefficients

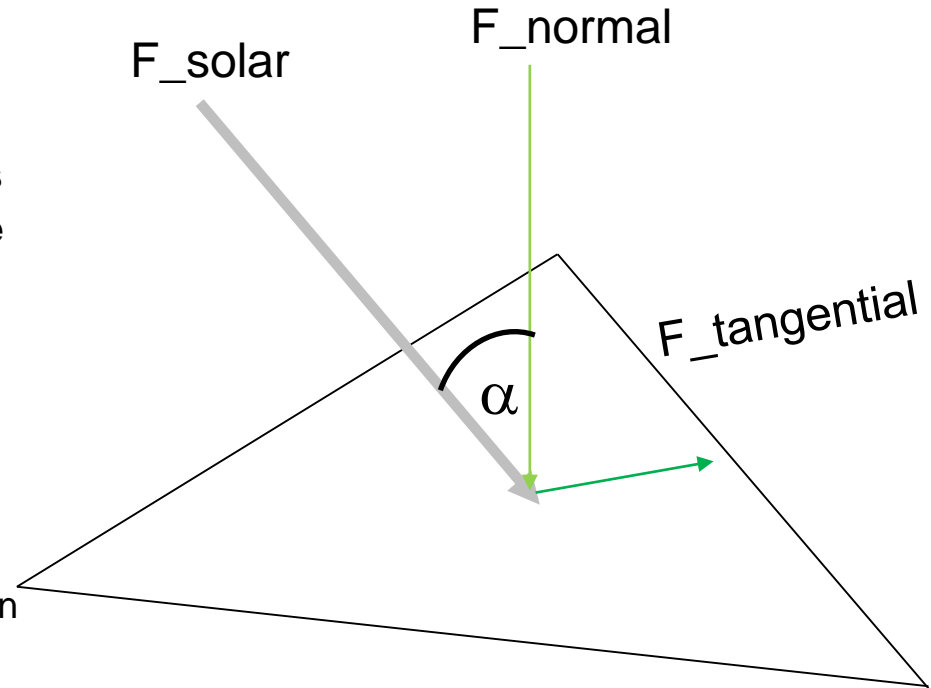

ϵ_f, ϵ_b = front and back side emissivities

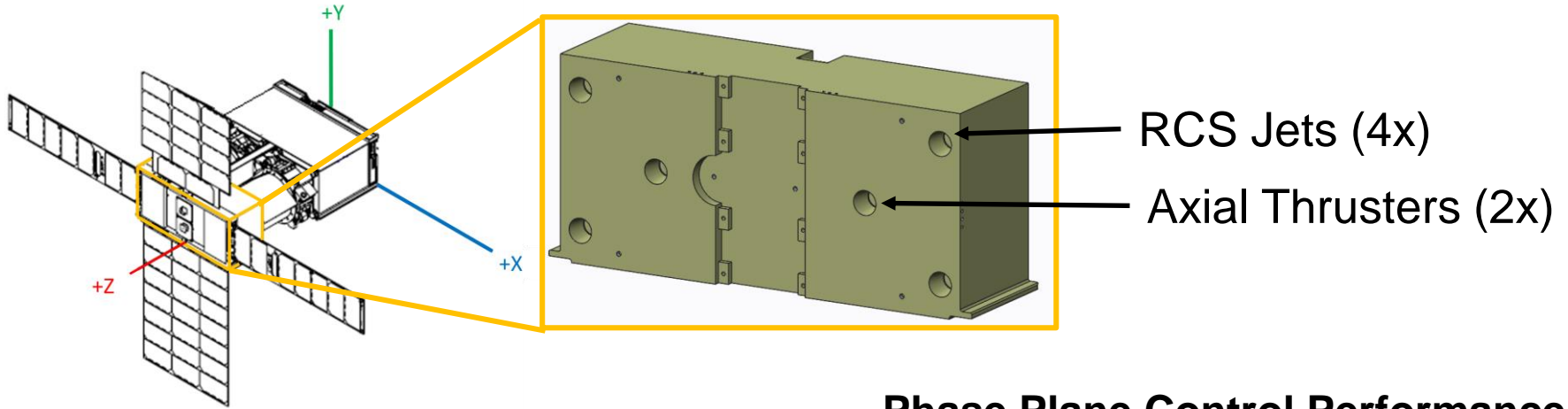

$$f_n = PA \left\{ (1 + \tilde{r}s) \cos^2 \alpha + B_f(1 - s)\tilde{r} \cos \alpha + (1 - \tilde{r}) \frac{\epsilon_f B_f - \epsilon_b B_b}{\epsilon_f + \epsilon_b} \cos \alpha \right\}$$

$$f_t = PA(1 - \tilde{r}s) \cos \alpha \sin \alpha t$$



-  Approx. CM Location
-  RCS Jet Thrust

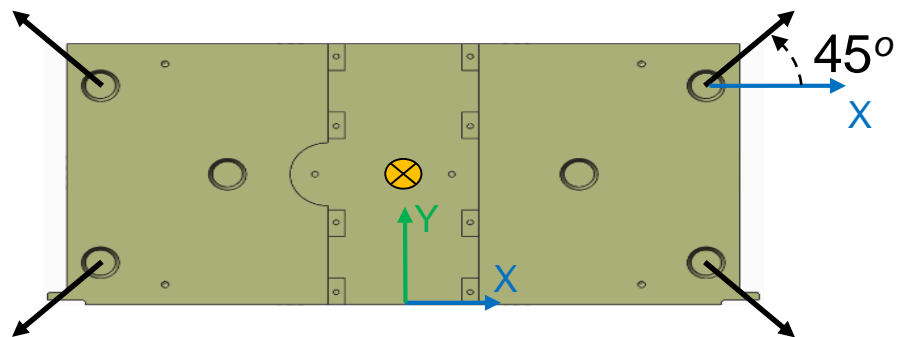

Phase Plane Control Performance

