

# High Efficiency Planar Arrays and Array Feeds for Satellite Communications

Zhenchao Yang, Kyle Browning, and Karl Warnick  
Department of Electrical and Computer Engineering  
Brigham Young University, Provo, Utah, USA  
yzcown@gmail.com, warnick@ee.byu.edu

**Abstract**—Limited scan range beamsteering can serve as a cost-effective solution for three application scenarios in satellite communications. Two feasible technical paths to realize the function are discussed in this paper. The first one is to utilize a electronically steered array feed with a conventional parabolic reflector. By feeding the reflector with different weights across the array feed, the phase distribution on the dish aperture is continuously shifted leading to a steered beam. Acquisition and tracking functions can be realized economically by integrating a power detector based feedback system. A necessary calibration process is provided to ensure a correct indicator of signal-to-noise ratio. One dimensional beamsteering was demonstrated experimentally and an improved two dimensional system is shown as well. The second path is to use a tile array with each tile consisting of a passive network fed subarray, which reduces the cost of active components significantly, at the expense of beamsteering range. The rule of the relationship between tile distance and element distance is discussed. Preliminary array factor analysis shows the sidelobe level of a uniformly excited array panel exceeds the regulatory pattern mask requirement.

## I. INTRODUCTION

Satellite communication (Satcom) services are used worldwide for voice, data, and video links due to many appealing features. One satellite can create a wide footprint, which theoretically enables global coverage except for pole areas by using three satellites. Another advantage is that satellites as central hubs directly establish links with end-users, solving the last mile problem fundamentally. Satellite communications are appealing for rural, remote, and ocean areas and high altitude air, where other telecommunication infrastructures are expensive or impossible to build.

Direct broadcast service (DBS) and fixed satellite service (FSS) use geostationary orbital (GEO) satellites to provide services to vast areas. Thanks to fixed satellite position in the sky, a terrestrial transceiver only needs a fixed high gain antenna to communicate with a GEO satellite. Parabolic reflector antennas are typically used to serve a cost effective scheme for commercial applications. In-motion terminals like luxury cars, ships and airplanes require beam steering. A full aperture-type electronically steerable phased array panel can fulfill the task perfectly, but is too costly for consumer use [1]. Mechanical steering based on inertial and GPS systems is still the only feasible method to date in commercial applications in spite of bulky size and heavy weight.

Limited scan range beam steering fills the technique and application gaps between full aperture phased arrays and

mechanical steered dishes. From a technical point of view, precisely beam steering in limited scan range plus coarse mechanical steering opens the third option for full beam steering with potential lower cost and higher tracking speed and accuracy than current barely mechanical steering, particularly for multi-feed systems. There are also three common scenarios that conventional fixed-mount dishes can not serve well. First, current dish installation demands accurate pointing. Lowering the accuracy requirement would increase the productivity of dish installation. Second, mount degradations caused by sagging roof and weather disasters require dish re-pointing, which costs millions of dollars in the Satcom industry. Automatic self-adjustment on beam direction avoids huge labor cost for trivial cases. Last but not least, a fuel-depleted satellite becomes inclined on its orbit, forming a constant ‘8’ shape movement in the sky. Spectrum resource on this kind satellite is cheap due to unstable connection, but the terrestrial stations have to track the movement by beam steering. Limited scan range beam steering is noteworthy as a cost-effective solution for aforementioned three applications.

This paper introduces the progress of our two research paths to achieve limited scan range beam steering. The first path is to utilize active array feeds on a conventional stationary parabolic reflector. By setting beamforming weights for elements, different phase distributions on the dish aperture can be formed, resulting in steered beams correspondingly. The second path is to excite passive subarray tiles instead of elements actively of a large array panel so that the cost of RF front-end circuits is reduced significantly.

## II. ELECTRONICALLY STEERED ARRAY FEED

Active array feeds provide a cost-effective solution to enable a conventional parabolic reflector antenna the beam-steering capability by replacing its low noise block feed (LNBF). A typical reflector antenna has the feed antenna at the focal point so that the phase distribution on the dish aperture plane is uniform leading to broadside radiation. If the feed antenna is off from the focal point but still on the focal plane, the phase distribution varies approximately linearly across the dish aperture which can be considered as a continuous phase shifted aperture. By locating the feed at different position on the focal plane, the beam can be steered off from broadside according to the phase shifting rate [2]. This technology has been applied on spot beam satellites to provide customized

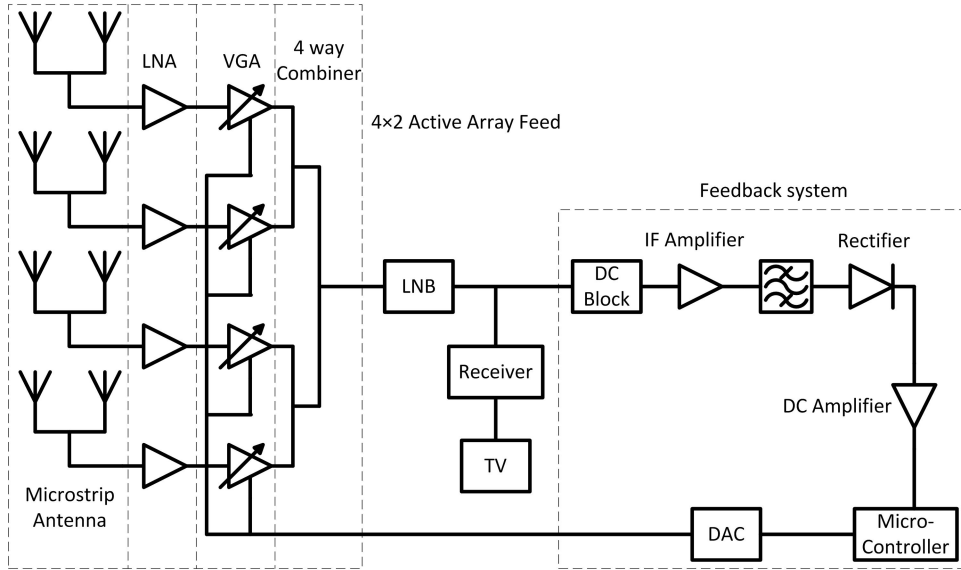

Fig. 1. Block diagram of the active planar feed array for beam steering.

programs for different areas [3] and multiple pixel receivers in radio astronomy [4]. The disadvantage of these array feeds is that each beam is fixed with one electrically large waveguide type feed and areas between two spot beams are not covered.

Arrays of electrical small elements following with beamforming networks provide a full coverage on foot print with the continuously changeable phase center on the focal plane, which has been implemented in Satcom [5] and radio astronomy [6]. If the feed location is too far from the focal point, the phase distribution can not be approximated as linear any more, leading to necessary corrections with expensive phase shifters [7]. In radio astronomy, the beamforming is realized in digital processing based on the digitized array signals after frequency downconversion, which offers all possible receiving beams. Changing the beam direction merely needs to apply different weights to each channel. The drawback is heavy cost on high performance digital signal processing (DSP) servers and downconverting circuits and analog-to-digital converter (ADC) required for each channel.

Considering the strict low cost requirement for commercial products, we used a totally different architecture, applying beam weights through variable gain amplifiers (VGA) and combining each channel before downconversion. The weights are adjusted through the feedback loop through the power detection output based on calibration. Limiting the scan range makes no-phase-shifter array feed more affordable. In this way, the array feed can cost-effectively steer the secondary beam of a conventional dish by simply varying the gain of each active element. In this section, we demonstrate an  $4 \times 2$  active array feed for one dimensional beam steering and show the progress of our  $4 \times 4$  active array feed for future two dimensional sweeping.

#### A. $4 \times 2$ active array feed system

The electronically steered array feed (ESAF) system includes two subsystems, a  $4 \times 2$  array with variable gain amplifiers (VGA) and a feedback system for the VGAs, as shown in Fig. 1. As demonstrated in [8], [9], a  $2 \times 2$  microstrip array feed provides sufficient illumination for a typical offset parabolic reflector. To simplify the system requirement, our first objective was set to double the receiving range in one dimension by beamsteering. As a result, the array consists of four pairs of cavity-backed microstrip antennas which was chosen as its superior isolation performance. Each output of the antenna pair is connected to a low noise amplifier (LNA) to minimize the large loss occurred at the VGA stage so that an acceptable signal-to-noise ratio (SNR) can be maintained. A T-junction type corporate network combines signals from the four channels. The array feed was designed to receive free-to-air (FTA) signals from 11.7 to 12.2 GHz. The fabricated and assembled array feed is shown as Fig. 2.

A commercial low noise block (LNB) was utilized to downconvert the combined Ku band signal to intermediate frequency (IF), followed by a T-junction connector to allow TV receiver and the feedback system to process IF signals simultaneously. Since the LNB needs an external DC power supply from the receiver, a DC block was used to protect the feedback system. A rectifier type power detector was used to transform the IF signal into DC current. Because the detector can receive signals from 10 to 8000 MHz, an IF bandpass filter was added before it to exclude unwanted noise. To make the detector work in the linear response region, an IF amplifier was placed before the filter. A microcontroller can read the analog input, run acquiring or tracking algorithms, and output addresses and digital signals to the digital-to-analog converter (DAC). The analog signals are the control voltages for the four VGAs. This feedback system was constructed as shown

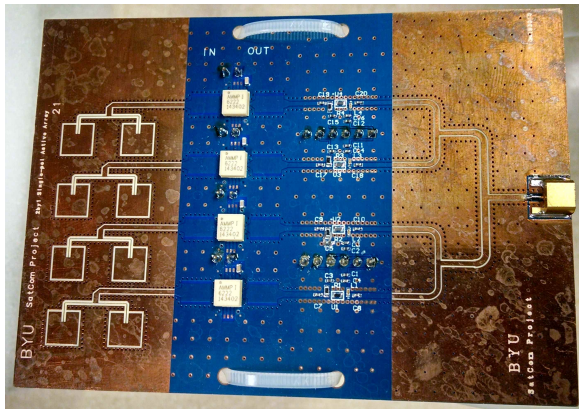

Fig. 2. System board of the active planar feed array for Ku band.

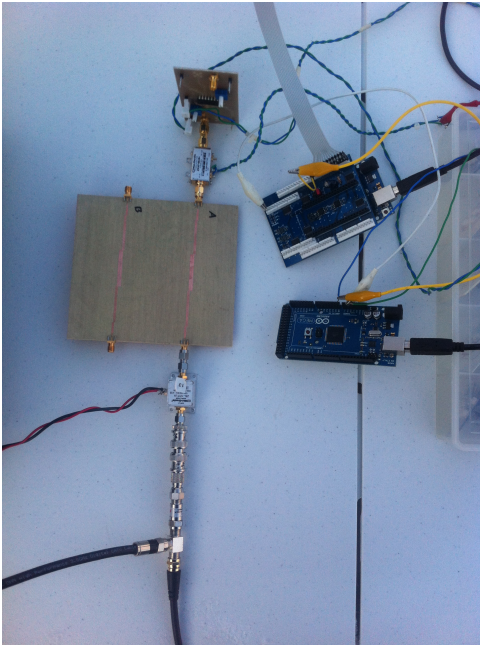

Fig. 3. Feedback system for the VGAs.

in Fig. 3.

With the two subsystems, an LNB, and a TV receiver, on-reflector testing can be carried out as shown in Fig. 4. The dish was first pointed to an satellite providing FTA signals, Galaxy 19 in our experiment, by maximizing the SNR with a typical LNBF. The ESAF was then put on the dish with a hand-made mounting structure based on the positioning platform of a tripod which offers adjustments in roll, pitch, yaw, height, and focus. To ensure the center of the ESAF is located at the focus point, fine tuning in the five freedoms of the platform for the maximum SNR was conducted in the condition of activating the center two channels. Based on the above two alignments, optimal beam weights can be found for each dish position controlled by a precise motor. Fig. 5 shows a measured SNR comparison of a horn feed and the ESAF as the dish was steered to different relative azimuth angle. Although the ESAF



Fig. 4. The whole system under test on a dish.

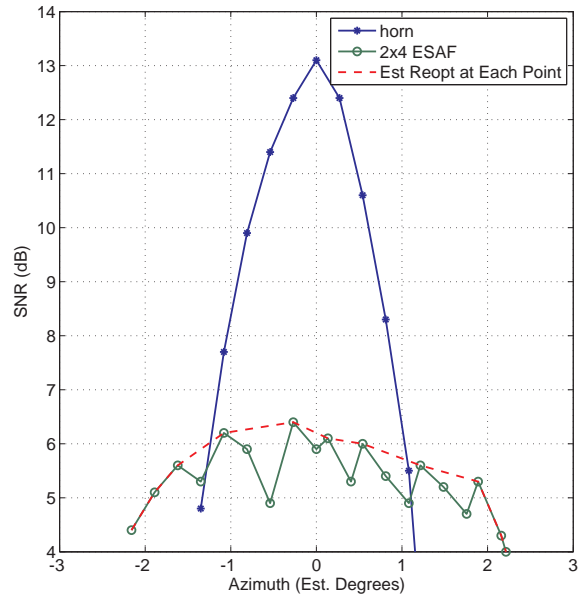

Fig. 5. Measured SNR comparison for a commercial horn feed and electronic steered array feed as a function of the dish azimuth angle.

gives lower SNR values, its working range with SNR larger than 4 dB is two times the range of the horn. The variation of the ESAF SNR is caused by simplified testing procedure which re-optimizes beam weights only when SNR drops below 4 dB. In addition, there were only five variable gain values used in the measurement to save search time. Lower SNR of the ESAF is caused by the packaged LNA with 1.5 dB higher noise figure (NF), lower antenna radiation efficiency, transmission line loss before LNAs, and large NF of VGA at some states.

Since our acquiring and tracking are based on the power detector output. The absolute values are meaningless because the output includes noise contribution which can be dominating. So a calibration is necessary to extract the noise response of the different optimal beam weights, which was accomplished by pointing the dish to the cold sky and recording the power detector output. When the satellite was back to the steering range of the ESAF, the same set of beam weights was swept again with the power detector output recorded. The acquisition is finished by setting the beam weights to the one with the largest difference between two output sets. The tracking mode was switched on after acquiring. To maintain the link, 3 point search method was used for tracking. In this way, the microcontroller only switches the beam weights to the two neighbors of current status. If better position is found, the VGAs would be set to the corresponding weights. Our test showed the ESAF can track the satellite successfully as the dish is steered within the  $4^\circ$  range. The feedback system, system calibration, and algorithms are described in detail in [10].

### B. $4 \times 4$ active array feed

Based on the successful  $4 \times 2$  ESAF, a  $4 \times 4$  ESAF board was designed with improved performance based on high efficiency antenna elements and less transmission lines before LNAs. The top and bottom sides of the ESAF are shown in Figs. 6 and 7. The stackup consists of a 60 mil RO4003C laminate for cavity-backed microstrip antennas, a 20 mil RO4003C laminate for RF front end circuits and a 16:1 combining network, and an FR4 epoxy laminate applied between the two RO4003C laminates. Thickness 60 mil was chosen for microstrip antennas because it can support high radiation efficiency while keep surface waves and cross polarization under reasonable levels [11]. Each microstrip element is backed by a via-fenced cavity to increase isolation between elements. The RF front end circuit is same with that of the  $4 \times 2$  ESAF, except for the inner four channels which have a  $360^\circ$  transmission line between LNAs and VGAs to fit all components on the same layer and simplify the 16:1 combining network. The combining network was realized by three stages of T-junctions and quarter wavelength transformer at the output of each junction. With VGAs for all 16 elements, this ESAF system can steer the beam in two dimensions with  $4^\circ \times 4^\circ$  range .

## III. TILE ARRAY

Currently a full aperture array for commercial satellite communication is not available because of the prohibitive cost and design complexity. These disadvantages are caused by the fact that each antenna element needs its own transmitting/receiving (T/R) module with phase and gain controller inside. This architecture is necessary for scenarios like radar, which need to scan the beam across a broad range. However, a limited scan range is actually able to satisfy requirements for many commercial applications such as mobile direct broadcasting satellite and very-small aperture terminal (VSAT), for which

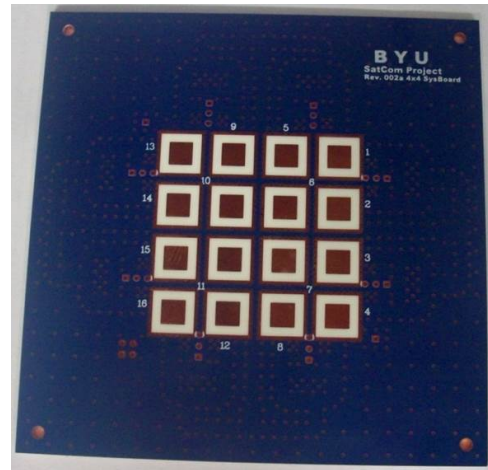

Fig. 6.  $4 \times 4$  cavity-backed antenna array feed.

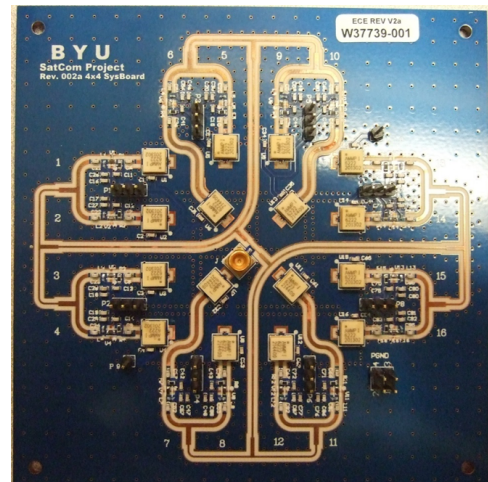

Fig. 7. RF front end of the  $4 \times 4$  array feed.

the target is stationary and the antenna can be roughly pointed to the satellite at installation.

The limited scan function can be realized cost-effectively by integrating  $N \times N$  elements into one tile with a passive distribution network and only providing a T/R module for one tile. The cost of the active components will drop significantly relative to the original full aperture array, which is an appealing feature especially for commercial products. One key for this limited scan array is to design a high efficiency active  $N \times N$  sub-array. The final array will unite  $M \times M$  tiles with a combining network and the total size is determined by the application requirement. A  $4 \times 4$  tile array with each tile consisting of  $4 \times 4$  elements is shown in Fig. 8.

Since elements inside a tile need to be fed by passive networks, the boarder area of the tile may be occupied to facilitate the network design, especially for dual polarization systems (two way or same frequency). In this case, the distance between tiles  $d_t$  would be larger than 4 times the element distance  $d_e$  referred in Fig. 8. A simple 1-D array factor equation was used to calculate the array factors of 4 elements,

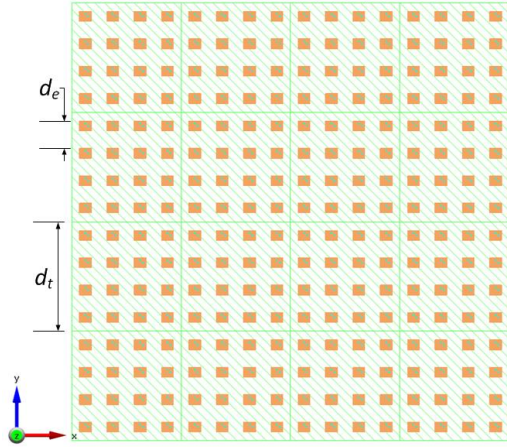

Fig. 8. Array panel consisting of  $4 \times 4$  tiles.

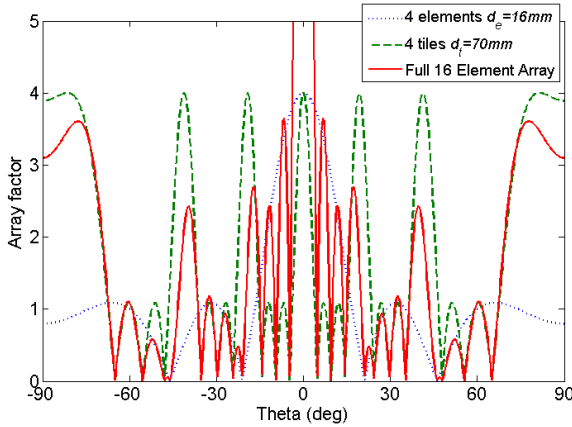

Fig. 9. Array factors of 16 elements with different element distance inside a tile and between tiles at 13 GHz.

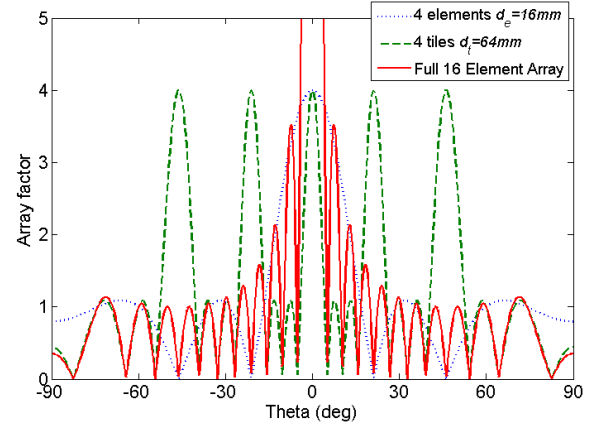

Fig. 10. Array factors of 16 elements with same element distance inside a tile and between tiles at 13 GHz.

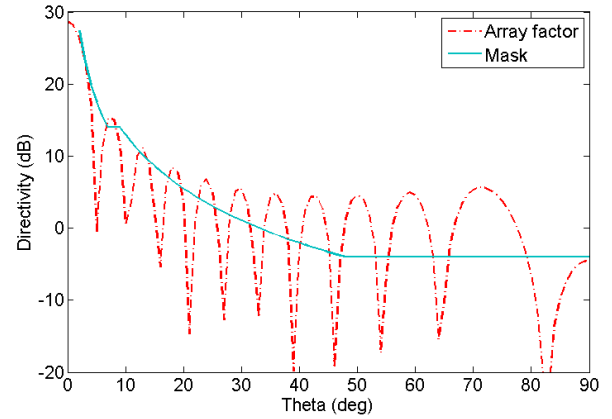

Fig. 11. The mask requirement for transmitting patterns and array factor of a uniformly excited  $16 \times 16$  array with element distance equal to 16 mm at 13 GHz.

4 tiles, and 16 elements for two different cases as shown in Fig. 9 and 10. The results show that unequal element distance at tile junctions causes non-monotonic sidelobe level, which is inconvenient to meet the sidelobe level requirement. The reason for this phenomena is the misalignment between the grating lobes of the tile array factor and the zeros of the element array factor. As a simple rule of thumb, when implementing a rectangular array, same element distance should be used to suppress unwanted sidelobes.

To serve as a VSAT terminal, the transmitting pattern of the whole antenna must comply with the pattern mask requirement as shown in Fig. 11. The array factor pattern at 13 GHz of a uniformly excited  $16 \times 16$  array with element distance equal to 16 mm, which is necessary for an acceptable link between terrestrial terminals and a VSAT satellite, was added into the same figure. The comparison illustrates that it is hard to meet the mask requirement if uniformly exciting all elements. To solve that, tapers on the array have to be implemented.

Besides the above issues, there are three major difficulties in antenna design for VSAT application. First high antenna efficiency is required to achieve the required G/T. Second

high isolation between transmitting and receiving (Tx/Rx) is important for good receiving performance. The last one is to design low loss distribution networks for both bands in low loss and low cost. These challenges have been addressed in my upcoming paper [12].

#### IV. CONCLUSION

One dimensional limited scan range beamsteering was demonstrated experimentally by the  $4 \times 2$  ESAF with VGAs. Acquiring and tracking functions were realized with the power detector based feedback system. The ESAF was re-designed with the  $4 \times 4$  high efficiency array to upgrade beamsteering into two dimensions. The limited scan range beamsteering can also be implemented cost-effectively by using a tile array with each tile consisting of a passive network fed subarray. The simple rule to maintain monotonic sidelobe level is to keep the same element distance through the whole array panel. The sidelobes of an uniformly excited array exceeds the regulatory pattern mask, requiring further investigation.

## REFERENCES

- [1] R. Baggen, S. Vaccaro, D. L. Rio, R. T. Sanchez, and G. Langgartner, "First prototyping of a compact mobile ku-band satellite terminal," in *Proceeding of the 4th European Conference on Antennas and Propagation EuCAP*, Barcelona Spain, April 2010, pp. 1–2.
- [2] A. W. Rudge and M. J. Withers, "New technique for beam steering with fixed parabolic reflectors," *Electrical Engineers, Proceedings of the Institution of*, vol. 118, no. 7, pp. 857–863, 1971.
- [3] S. K. Rao, "Parametric design and analysis of multiple-beam reflector antennas for satellite communications," *Antennas and Propagation Magazine, IEEE*, vol. 45, no. 4, pp. 26–34, 2003.
- [4] L. Staveley-Smith, W. Wilson, T. Bird, M. Disney, R. Ekers, K. Freeman, R. Haynes, M. Sinclair, R. Vaile, and R. Webster, "The parkes 21 cm multibeam receiver," *Publications of the Astronomical Society of Australia*, vol. 13, pp. 243–248, 1996.
- [5] M. Schneider, C. Hartwanger, and H. Wolf, "Antennas for multiple spot beam satellites," *CEAS Space Journal*, vol. 2, no. 1, pp. 59–66, 2011.
- [6] K. F. Warnick, D. Carter, T. Webb, J. Landon, M. Elmer, , and B. D. Jeffs, "Design and characterization of an active impedance matched low noise phased array feed," *IEEE Transactions on Antennas and Propagation*, vol. 59, no. 6, pp. 1876–1885, 2011.
- [7] Y. Wu, K. F. Warnick, and J. Chengjin, "Design study of an l-band phased array feed for wide-field surveys and vibration compensation on fast," *Antennas and Propagation, IEEE Transactions on*, vol. 61, no. 6, pp. 3026–3033, 2013.
- [8] Z. Yang and K. F. Warnick, "A planar passive dual band array feed antenna for ku band satellite communication terminals," in *IEEE Antennas and Propagation Society International Symposium (APSURSI)*, 2012, pp. 1–2.
- [9] —, "Multiband dual-polarization high-efficiency array feed for ku/reverse-band satellite communications," *Antennas and Wireless Propagation Letters, IEEE*, vol. 13, pp. 1325–1328, 2014.
- [10] K. C. Browning, "Passive and electronically steered array planar feeds for satellite communications," Master Thesis, Brigham Young University, 2014.
- [11] Z. Yang, K. F. Warnick, and C. L. Holloway, "A high radiation efficiency microstrip array feed for ku band satellite communication," in *IEEE Antennas and Propagation Society International Symposium (APSURSI)*, 2013, pp. 1–2.
- [12] Z. Yang and K. F. Warnick, "Planar 4×4 microstrip array tile design for a limited scan range steered beam vsat system," *Antennas and Propagation, IEEE Transactions on*, in prepration.