

# PULSED PLASMA THRUSTER TECHNOLOGY FOR SMALL SATELLITE MISSIONS

Roger M. Myers and Steven R. Oleson  
Nyma, Inc.  
NASA Lewis Research Center  
Cleveland, OH 44135

Melissa McGuire  
Analex Corp.  
NASA Lewis Research Center  
Cleveland, OH 44135

Nicole J. Meckel and R. Joseph Cassady  
Olin Aerospace Company  
Redmond, WA

## Abstract

Pulsed plasma thrusters (PPTs) offer the combined benefits of extremely low average electric power requirements (1 to 150 W), high specific impulse (~ 1000 s), and system simplicity derived from the use of an inert solid propellant. Potential applications range from orbit insertion and maintenance of small satellites to attitude control for large geostationary communications satellites. While PPTs have been used operationally on several spacecraft, there has been no new PPT technology development since the early 1970's. As a result of the rapid growth in the small satellite community and the broad range of PPT applications, NASA has initiated a development program with the objective of dramatically reducing the PPT dry mass, increasing PPT performance, and demonstrating a flight ready system by October 1997. This paper presents the results of a series of near-Earth mission studies including both primary and auxiliary propulsion and attitude control functions and reviews the status of NASA's on-going development program.

## Introduction

The continuing emphasis on cost reduction and spacecraft downsizing is forcing increased emphasis on reducing subsystem mass and integration costs. For many commercial, scientific, and DoD missions, on-board propulsion is either the predominant spacecraft mass or limits the spacecraft lifetime. Additional pressures resulting from the emphases on use of smaller launch vehicles, new spacecraft architectures, and the costs associated with ground testing and handling toxic or hypergolic propellants have also led to the consideration of alternative propulsion technologies. The characteristics of pulsed plasma thrusters make them uniquely suited for providing a very simple, light weight, low volume, high performance propulsion option for power-limited small satellites.

Pulsed plasma thrusters rely on the Lorentz force generated by the interaction of an arc passing from anode to cathode with the self-induced magnetic fields to accelerate a small quantity of ablated chlorofluorocarbon propellant. As shown in Figure 1, the thruster system consists of the accelerating electrodes, energy storage unit, power conditioner, ignition circuit, propellant feed system, and telemetry. During operation, the energy storage capacitor is first charged to between 1.5 and 2.5 kV. The ignition supply is then activated to generate a low density plasma which permits the energy storage capacitor to discharge across the face of the chlorofluorocarbon propellant bar. This arc ablates, heats, and accelerates the propellant to generate thrust. Peak arc current levels are typically between 2 and 15 kA, and the arc

duration is between 5 and 20  $\mu$ s. The pulse cycle is repeated at a rate compatible with the available spacecraft power. This ability to use the same thruster over a wide range of spacecraft power levels without sacrificing performance or having a complex throttling algorithm is one of the advantages of PPTs. The propellant feed system consists solely of a negator spring which pushes the solid chlorofluorocarbon bar against a stop on the anode electrode, eliminating safety and reliability concerns with valves or pressurized systems. There are no other moving parts on the PPT, resulting in a propulsion system which is extremely inexpensive to integrate onto spacecraft and can be stored indefinitely with little concern for storage environment. The latter was recently demonstrated when PPTs stored for over 20 years were successfully fired at both the NASA Lewis Research Center (LeRC) and the Olin Aerospace Company (OAC). The largest mass components of the PPT are the energy storage unit (a capacitor or pulse-forming network) and the system electronics, including the power conditioning unit, discharge initiation, and logic and telemetry circuits. Recent developments in these technologies provide several options which can result in a system mass reduction by a factor of two.

PPTs were extensively developed in the late 1960's and early 1970's. Figure 2 shows the range of impulse bits demonstrated on flight or flight-qualified systems. The PPT system developed during that period with the most flight experience was used on the Navy's TIP/NOVA navigation satellites and operated at a peak power level of 30 watts during firing. The NOVA PPT had a specific impulse ( $I_{sp}$ ) of 543 s, an impulse bit of 400  $\mu$ N-s, a total impulse capability of 2450 N-s, and a fueled system mass of 6.8 kg.<sup>1</sup> The baseline technology for the new NASA program is the flight-qualified LES 8/9 PPT system, which was selected because of its higher  $I_{sp}$  of 1000 s and demonstrated total impulse capability of 10,500 N-s.<sup>2</sup> The LES 8/9 operated at power levels of 25 or 50 W, produced an impulse bit of 300  $\mu$ N-s, and had a fueled system mass of 6.7 kg.<sup>2</sup> As discussed in detail below, the initial NASA program objectives are to decrease the fueled system mass to 3.5 kg while

providing a total impulse of 20,000 N-s. These objectives will be accomplished via use of recently developed capacitors, integrated circuit technology for both telemetry and power electronics, new structural materials, and an increase in PPT performance. Extensive laboratory testing has demonstrated that PPTs could be built to provide over 2000 s  $I_{sp}$  at over 20% efficiency.<sup>3</sup> Following completion of the initial program, an effort is planned to continue miniaturizing the PPT if there is sufficient interest in the small spacecraft community.

The very low power requirements, small size, and simplicity of integration make PPTs suitable for a range of small satellite missions. To demonstrate the potential applications, a set of potential PPT missions were analyzed, including orbit maintenance of a small satellite in sun-synchronous orbit, drag make-up and orbit raising for a shuttle launched small satellite, orbit raising and drag make-up for the spacecraft in the Teledesic constellation, and momentum wheel replacement for attitude control of both large and small satellites. Following a description of these mission examples, NASA's PPT development program is summarized including the contracted flight system development program, efforts to explore more advanced PPT options, and studies of spacecraft integration requirements.

### Mission Application Examples

The PPT system assumed for the mission application studies provided either 1000 or 1500 s  $I_{sp}$  at an efficiency of 15% and was capable of providing 20,000 N-s total impulse. A fueled system mass of 3.5 kg was used, with operating power levels between 1 and 150 W. Throttling is achieved by varying the pulse frequency at a constant performance level. These assumptions are consistent with the objectives of NASA's PPT flight system development program.

#### Orbit Maintenance

Two orbit maintenance missions were examined. The first, maintenance of a 100 kg satellite with a 0.38 m<sup>2</sup> cross-section in a sun-

synchronous orbit for five years, had a total mission velocity change requirement of 122 m/s. This mission, if performed by a standard hydrazine monopropellant propulsion system, would require a propulsion system dry mass of 19.3 kg with 7 kg of propellant. The monopropellant system would have a volume of 0.022 m<sup>3</sup>. To perform the same mission, a PPT system would weigh 8.4 kg (two thrusters) and carry 1.36 kg of propellant, requiring a volume of 0.012 m<sup>3</sup>. The PPT would consume less than 5 W of electrical power during the mission. The 18 kg propulsion system mass reduction achieved using PPTs could be used to increase payload mass or, if multiple satellites were launched on a single launch vehicle, the total launch mass savings would result in a substantial increase in initial delivered altitude. This increase could be over 300 km if eight spacecraft were launched on a Pegasus XL.

The second orbit maintenance mission studied was the use of PPTs for drag make-up of small satellites launched out of a Space Shuttle Get-Away-Special Canister (GAS CAN). This analysis assumed a spacecraft mass of 60 kg with a 0.2 m<sup>2</sup> cross-sectional area launched into an initial orbit at 320 km. Three options were considered, including no propulsion, a PPT thrusting at 50 W only while the arrays were illuminated, and a PPT thrusting at 50 W continuously throughout the orbit. An atmospheric drag model was used corresponding to the average density during the 1992 solar maximum.<sup>4</sup> Results for the three options are shown in Figure 3, from which it is evident that use of PPTs can greatly extend the satellite lifetime. If batteries can be used to permit continuous firing, then the orbit can be indefinitely maintained. If the PPT can only be fired while the arrays are illuminated, the satellite lifetime can be doubled. The detailed results are, of course, sensitive to the initial orbit.

#### Orbit Insertion and Deorbit

At higher initial orbits drag is reduced, resulting in a lower average PPT power requirement for drag make-up. Alternatively, firing the PPT at the same average power level results in raising the orbit if the mission starts from a higher initial orbit. This is clearly illustrated by

considering a 50 kg satellite with a cross-sectional area of 0.43 m<sup>2</sup> launched from the Shuttle at altitudes between 375 and 425 km. Worst case atmospheric drag was again assumed. For these cases, a constant PPT power level of 30 W was assumed with the thruster either operating only when the arrays were illuminated or continuously throughout the orbit. As discussed above, the latter would require that the spacecraft power system include batteries capable of providing 30 W throughout the shaded period of the orbit. The 30 W power level limited the PPT thrust level to 0.92 mN. Results are shown in Table 1, from which it can be seen that the PPTs can raise the spacecraft orbit for either the continuous or illuminated-only thrusting cases. The long transfer times could be reduced by increasing the power level should it be available. The trip time will decrease nearly in direct proportion to the increase in power level with no change in the propellant mass required. Note that once the spacecraft has been inserted in its final orbit, the orbit can be controlled by firing the PPT at a lower average power level simply by reducing its pulse frequency.

An example of PPT applications for larger satellites is their potential use on the Teledesic constellation spacecraft. All data for this trade study were taken from the recent Teledesic FCC filing.<sup>5</sup> As then envisioned, the Teledesic propulsion system would deliver the 795 kg (beginning-of-life) spacecraft to a sun-synchronous, 700 km altitude orbit, maintain the orbit for 10 years, insert replacement satellites from parking orbits, and deorbit the spacecraft at end-of-life. Several possible satellite propulsion systems were examined, including exclusive use of 220 s I<sub>sp</sub> chemical thrusters, PPTs, and arcjets, and combinations of these technologies for different portions of the missions. PPTs providing either 1000 or 1500 s I<sub>sp</sub> were considered. Additionally, the large drag resulting from having the 144 m<sup>2</sup> solar array fully deployed during orbit raising resulted in an examination of the impact of deploying only one-third of the array during orbit raising. While this impacted the power available for this portion of the mission, there was still plenty of power margin available. Typical results for the spacecraft launch mass are shown in Figure 4. It is clear that exclusive

use of the 1500 s PPT results in the lowest overall launch mass. The final selection of the propulsion system would be based on transfer time considerations, including gap-filling and deorbit requirements.

### Attitude Control

The final PPT application considered in this paper is their use for attitude control of both large and small spacecraft. The large spacecraft were geosynchronous communications satellites with masses ranging from 1000 to 5000 kg and having arrays with projected areas from 20 m<sup>2</sup> to 120 m<sup>2</sup>. Attitude control for these satellites is currently performed using momentum wheels with a small chemical propulsion system for wheel desaturation. The spacecraft body envelope was assumed to be 2.5 m x 2.1 m x 2.8 m, and the center of pressure was assumed to be offset from the center of gravity by 10 cm. Attitude perturbations included the effects of solar radiation, gravity gradient, and aerodynamic torque. Twelve PPT thrusters, two on each face of the spacecraft, were grouped in sets of three about a capacitor and power processing unit, requiring four PPT electronic units to provide 3-axis control of the spacecraft. The PPTs were located at spacecraft corners to provide the largest torque for a given impulse bit. A ten year life was assumed to calculate the propellant requirement. Results are summarized in Figures 5a and b, which show the attitude control system mass for either momentum wheel or PPT systems as a function of both projected array area and the spacecraft mass. Note that both monopropellant hydrazine (Isp of 220 s) and bipropellant (Isp of 280 s) chemical systems were included as options for wheel desaturation. This system would not be required with the PPTs. As can be seen from the figures, the PPT system mass was between 15 and 100 kg lighter than the momentum wheel system, depending on the array size and the spacecraft mass. For both the momentum wheel and the PPT systems the propellant mass is very small, resulting in the minimal impact of propulsion system I<sub>sp</sub> or mission duration. Mission average PPT system power levels for this application are between .01 and .02 watts, and a PPT would fire an average of approximately once every 50 minutes for the duration of the mission. Note that the PPT

system could also be used for east-west stationkeeping by simply increasing the length of the propellant bars to add a total of 3.6 kg of propellant (for a 2000 kg spacecraft) distributed across the appropriate thrusters, permitting elimination of the small chemical propulsion system currently used and reducing the total number of systems on the spacecraft.

Attitude control for small spacecraft in low and middle Earth orbits (LEO and MEO) was examined for spacecraft masses between of 50 and 300 kg. Today these spacecraft use either a combination of momentum wheels and magnetic torque rods or passive gravity gradient stabilization. For the latter there is essentially no attitude control system, so no benefit would be derived from using PPTs for this function. A current example of an active attitude control system (ACS) on a small satellite is provided by the Total Ozone Mapping Spectrometer - Earth Probe mission, a 288 kg wet mass spacecraft currently awaiting launch, which has an ACS mass of 36.2 kg (27.6 kg of momentum wheels and 8.6 kg of torque rods).<sup>6</sup> For the PPT based ACS, a 0.9 m x 0.8 m x 1.0 m spacecraft envelope was assumed with two sets of energy storage and power electronics and 6 thrusters (three per energy storage unit). Using the new PPT technology currently being demonstrated, the ACS would weigh a total of 5.5 kg including the propellant needed for a 5 year mission, yielding a 30 kg reduction in spacecraft dry mass. The higher disturbance torque environment in LEO requires more frequent firing than for the GEO spacecraft, resulting in a mission average PPT power level of approximately 0.1 W, and a PPT firing approximately once every 7.5 minutes. Similar results are obtained with smaller spacecraft.

### PPT Program Status

NASA's PPT development program, managed by the Lewis Research Center (LeRC), consists of a contracted effort with the Olin Aerospace Company (OAC) to develop a lightweight, high performance flight system by October 1997 and efforts to explore advanced technology options which could be used to further enhance the thruster systems. Additionally, LeRC will evaluate spacecraft integration issues, including

electromagnetic interference and spacecraft contamination resulting from deposition of thruster exhaust. All three program elements are discussed below.

#### Flight System Development

Development work on the flight PPT at OAC has focused primarily on PPT system mass reduction and overall efficiency improvement. The system mass is being reduced primarily by using state-of-art electronics for the power conditioning, telemetry, and energy storage systems. The overall efficiency will be improved by optimizing the discharge electrode configuration and increasing the efficiency of the power electronics.

Extensive development of energy storage capacitors over the past two decades has resulted in a large improvement of their energy density. Shown in Figure 6 are the energy densities of the LES 8/9 jelly-roll capacitor, four modern jelly-roll capacitors, and a stacked ceramic capacitor. The latter five are currently under evaluation at OAC for use on the new flight system. Note that the energy densities for the jelly-roll capacitors have increased by factors between 3.9 and 14.8, depending on the allowed capacitor voltage, and by a factor of 1.8 for the stacked ceramic capacitor. This shows that the capacitor mass can be decreased by over a factor of two or more depending on the outcome of the capacitor lifetime evaluations currently underway.

New integrated circuit technology has also resulted in dramatic improvements in PPT systems. The LES 8/9 PPT power converter required unregulated 28 VDC and output 1500 VDC to charge the 17  $\mu$ F energy storage capacitor. The nominal charging frequency was 1 Hz, though the circuit was designed for 6 Hz capability. The maximum rated power was 120 W for 6 Hz operation. The LES 8/9 design used high power transistors to perform the switching in the power supply. For this program, a new power converter has been designed, breadboarded, and demonstrated with the capability of charging a 5000 VDC capacitor from the same unregulated 28 VDC input at 1 to 6 Hz. The power range is 25 to 150 W. This range is accomplished using a UC1845 PWM integrated circuit which reduces the mass by a factor of two and the number of components by

nearly a factor of five. The parts count reduction and other savings for the power converter circuit are shown in Figure 7, and a photograph comparing the LES 8/9 baseline electronics unit with the new power converter breadboard unit is shown in Figure 8. The large volume reduction is quite evident.

The LES 8/9 Logic/Telemetry circuit used a series of several multiple input gates to provide a high level of noise immunity and protection against false triggering. The new circuit design maintains this philosophy, but utilizes modern electronics developments such as Field Programmable Gate Arrays (FPGAs) to replace most of the discrete circuitry with a single chip. The savings in parts count, area, volume, and mass enabled by this approach are summarized in Figure 9. Note that the large reduction in electronics parts count should improve system reliability and reduce cost by decreasing manufacturing time.

Additional mass savings and volume savings are anticipated in the Discharge Initiation (DI) circuitry and the overall PPT structure. Detailed estimates of the DI circuit indicate a mass reduction from the 0.624 kg LES 8/9 system to 0.326 kg for the current development program. The structural mass reduction derives from the reduction in mass and volume achieved with the electronics and the capacitor. With an overall factor of two reduction in the volume of these major components, it is reasonable to estimate a factor of two reduction in the structure mass required to house them. Additionally, use of a single polyamide-imide structural material in place of the aluminum, G-10, and ceramic materials used in the LES 8/9 will further reduce the structural mass. The net effect of the structural material changes will be to reduce the system mass even further, though no additional volume savings are expected.

In addition to the system mass and volume reductions achieved using state-of-art electronics and structures, considerable effort will be placed in improving PPT performance. The LES 8/9 system provided 1000 s Isp at 8% efficiency. Significant improvements have been demonstrated in laboratory testing,<sup>3</sup> and every effort is being made to incorporate these improvements into the flight development

program. As part of this work, a matrix of 54 capacitor, fuel bar, and electrode configurations will be tested using a breadboard PPT. This matrix will include various electrode lengths, distances between the electrodes, electrode flaring angles, and capacitor configurations. The effect of discharge pulse shapes on the efficiency of the system will also be evaluated. After preliminary testing at OAC, the thruster configurations showing the most promise will be shipped to NASA LeRC for accurate performance assessments. A PPT thrust stand, accurate to within 1% for either single impulse bit or continuous pulsing thrust measurements, was recently completed and demonstrated at NASA LeRC.<sup>7</sup> All of this testing should be completed by March 1996 in order to permit design, fabrication, and qualification testing of the flight PPT units by October 1997.

#### Advanced Technologies

As part of the near-term flight development program, PPT system mass and performance models are being developed for use in scaling studies. In particular, the feasibility of a highly miniaturized PPT with a fueled system mass significantly below 1 kg is being assessed for application to NASA's New Millennium Program. This system would have an impulse bit between 10 and 100  $\mu\text{N}\cdot\text{s}$  and a system power level below 5 W. A mock-up of this system is shown in Figure 10 next to the LES 8/9 baseline system. As part of a grant effort at Ohio State University, alternative polymer propellants are being evaluated which may dramatically improve thruster performance by reducing the energy required to ablate the solid propellant and create the discharge plasma.<sup>8</sup> Computer codes capable of detailed PPT discharge simulations have been demonstrated and are being enhanced to model different polymers and discharge circuits.<sup>9</sup> These advanced technologies are focused on the flight systems for 1998 and beyond, though they could be moved forward should there be near-term interest in their application.

#### Integration Assessments

The potential for spacecraft contamination and electromagnetic interference (EMI) resulting from PPT firing must be assessed prior to their operation use. While extensive flight experience has been accumulated on several spacecraft,

new spacecraft architectures and more sensitive instrumentation make it difficult to transport the lessons learned on previous missions to those of today. It is important to note, however, that PPTs were mounted flush with body mounted arrays (thruster exit plane in the same plane as the solar arrays) on the LES-6 spacecraft and no array degradation attributable to the PPTs was noted over the five year spacecraft lifetime and 8900 hrs of on-orbit PPT operation.<sup>10</sup> The PPTs on the TIP/NOVA spacecraft were mounted in line with the solar array booms, firing across the arrays, and again no degradation attributable to the PPTs has been reported after over 20 years of combined thruster operation (15 million pulses).<sup>11,12</sup> There was an EMI issue on the NOVA I spacecraft which was resolved via a modification of the PPT grounding scheme and did not resurface on NOVA II or III.<sup>12</sup> These data notwithstanding, an effort to assess PPT contamination and EMI is underway at NASA LeRC using the large space simulation chambers available for testing. Preliminary testing to validate diagnostic techniques, including quartz slide deposition and plume plasma characteristic measurements, have been completed with the assistance of Worcester Polytechnic University. An assessment of PPT impacts on Global Positioning System receivers is also underway as part of the Joint Air Force/Weber State University Satellite (JAWSAT) program.

#### Conclusions

The large and expanding small satellite market has led NASA to develop on-board propulsion systems suitable for power and volume limited spacecraft. As part of this program, NASA LeRC is developing pulsed plasma thrusters for orbit maintenance, insertion, deorbit, and attitude control applications. Program objectives include a specific impulse between 1000 and 1500 s, a system efficiency of 15%, a total impulse capability of 20,000 N-s, a power throttling capability between 25 W and 150 W (during operation) and a fueled system mass of 3.5 kg. Mission analyses have shown that these characteristics provide large spacecraft mass reductions over state-of-art chemical propulsion and momentum wheel/magnetic torque rod systems for a wide range of spacecraft missions and spacecraft sizes. The PPT flight system

development program, performed under contract with Olin Aerospace, is currently in the breadboard design and fabrication stage. To date, power converter and logic/telemetry systems meeting the low mass requirements have been built and tested, and discharge initiation circuitry has been designed. Breadboard system testing should be complete by March 1996, and completion of flight system qualification is planned for October 1997. Additional efforts to develop advanced technologies for next-generation systems and to establish spacecraft integration requirements are also underway both at NASA LeRC and under grant to Ohio State University.

### References

- <sup>1</sup>Brill, Y., Eisner, A., and Osborn, L., "The Flight Application of a Pulsed Plasma Microthruster; The NOVA Satellite," AIAA Paper 82-1956, Nov. 1982.
- <sup>2</sup>Vondra, R.J. and Thomassen, K.I., "Flight Qualified Pulsed Electric Thruster for Satellite Control," J. Spacecraft and Rockets, Vol. 11, No. 9, Sept. 1974, pp. 613-617.
- <sup>3</sup>Myers, R. M., "Electromagnetic Propulsion for Spacecraft," AIAA Paper 93-1086, February 1993; see also NASA CR 191186.
- <sup>4</sup>Jensen, J., Townsend, G., Kork, J., and Kraft, D., "Design Guide to Orbital Flight," McGraw-Hill, New York, 1962.
- <sup>5</sup>Anon., "Application of Teledesic Corporation for a Low Earth Orbit (LEO) Satellite System in the Fixed Satellite Service (FSS), Teledesic Corporation, Kirkland, WA, March 21, 1994.
- <sup>6</sup>Personal Communication, Todd Mendenhall, TRW Space and Electronics Group, Redondo Beach, California, August 1995.
- <sup>7</sup>Haag, T.W., "PPT Thrust Stand," AIAA Paper 95-2917, July 1995.
- <sup>8</sup>Leiweke, R.J., Turchi, P.J., Kamhawi, H., and Myers, R.M., "Experiments with Multi-Material Propellants in Ablation-Fed Pulsed Plasma Thrusters," AIAA Paper 95-2916, July 1995.
- <sup>9</sup>Turchi, P.J. and Mikelleides, P.G., "Modelling of Ablation-Fed Pulsed Plasma Thrusters," AIAA Paper 95-2915, July 1995.
- <sup>10</sup>Guman, W.J. and Nathanson, D.M., "Pulsed Plasma Microthruster Propulsion System for Synchronous Orbit Satellite," J. Spacecraft, Vol. 7, No. 4, April 1970, pp. 409-414.
- <sup>11</sup>Kowal, S.J., "Post-Launch Results of the TIP Spacecraft Pulsed-Plasma Microthrusters," 1980 JANNAF Propulsion Meeting, Vol. 5, CPIA Publication 315, March 1980.
- <sup>12</sup>Ebert, W.L., Kowal, S.J., and Sloan, R.F., "Operational NOVA Spacecraft Teflon Pulsed Plasma Thruster System," AIAA Paper 89-2487, July 1989.

Initial Altitude, km	375	375	400	400	425	425
Final Altitude, km	512	625	425	612	450	650
Transfer Time, days						
Continuous thrusting	66	105	13	84	11	84
No thrusting in shade	184	247	31	153	22	143
Propellant Mass, kg	1.5	2.0	0.3	1.2	0.2	1.2

Table 1 - 50 kg spacecraft orbit raising missions for 30-W PPTs.

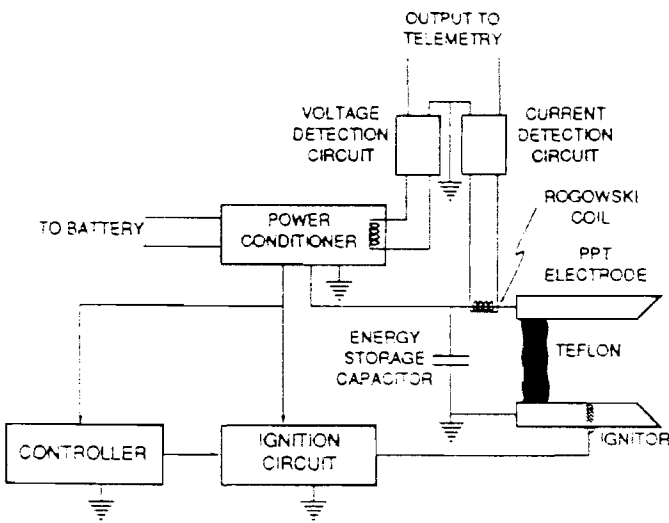

Figure 1 - PPT flight system schematic. Telemetry signals depend on application.

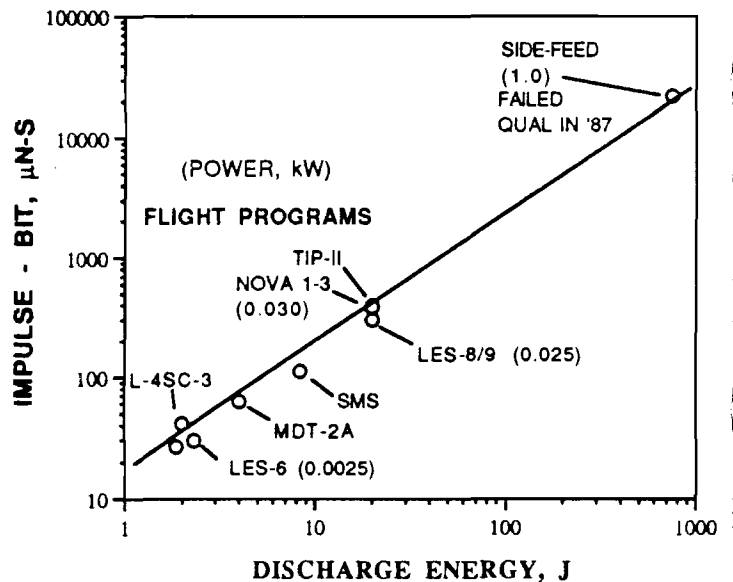

Figure 2 - Impulse bit vs. stored energy for a range of flight and flight-qualified PPT systems.



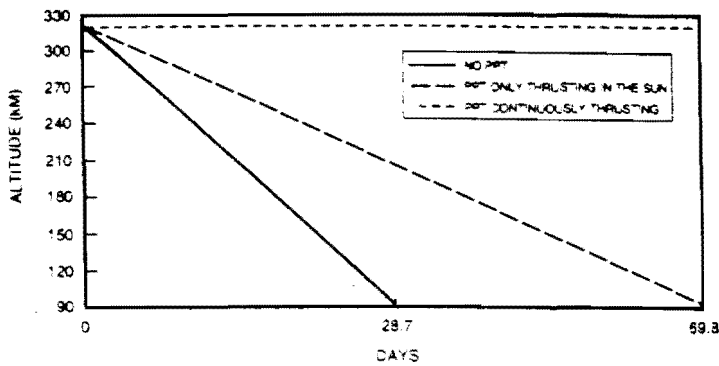
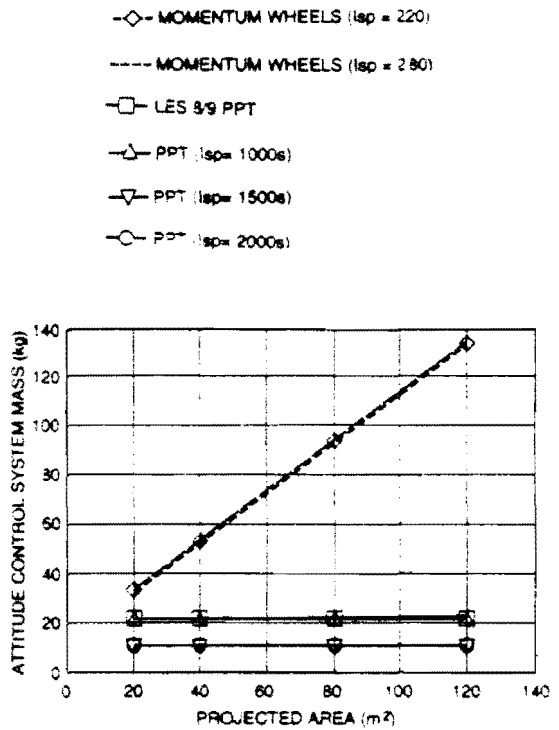

Figure 3 - Altitude decay of a 60 kg satellite with either no propulsion, PPT thrusting only in sunlight, or PPT thrusting continuously.



a. Solar array size effects.

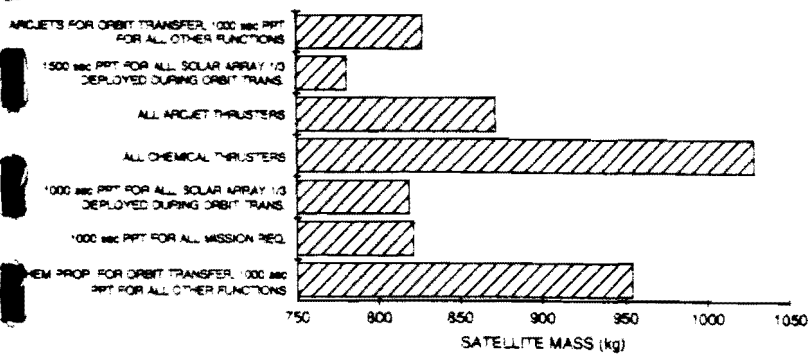
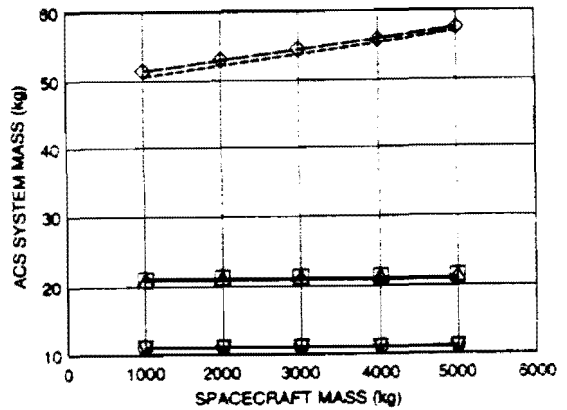

Figure 4 - Comparison of satellite launch masses for various propulsion options for the Teledesic mission.



b. Spacecraft mass effects.

Figure 5 - Attitude control system masses for geosynchronous spacecraft using either momentum wheel or PPT systems.

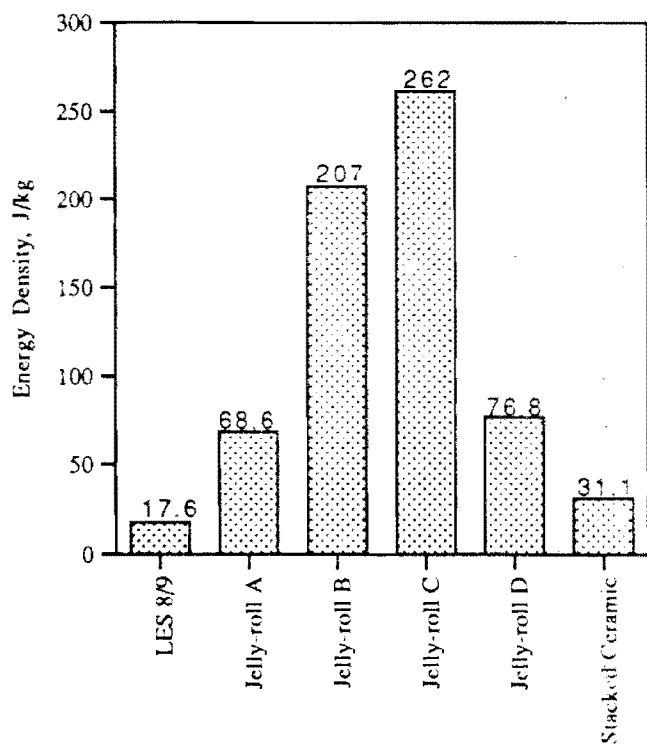

Figure 6 - Capacitor energy densities for both the LES 8/9 PPT baseline and current state-of-art capacitors.

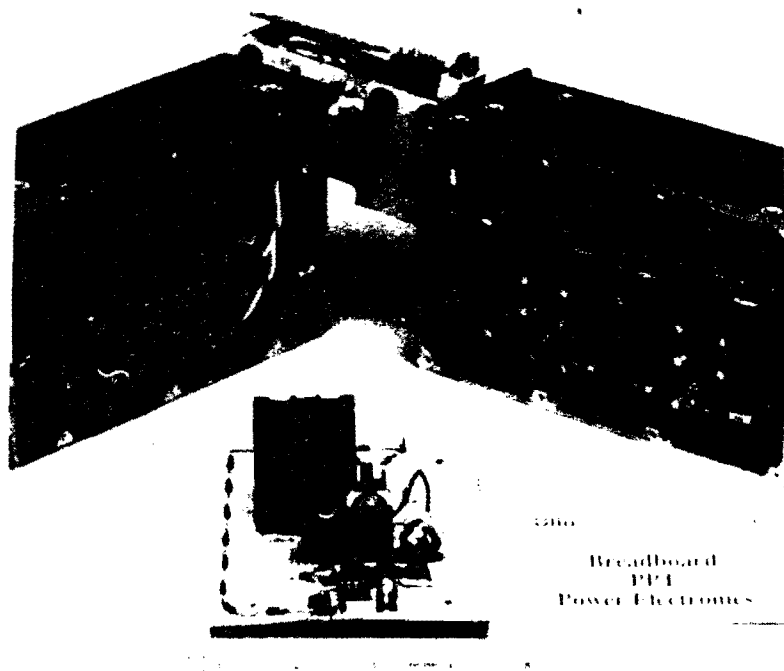

Figure 8 - Photograph showing LES 8/9 baseline electronics package with the new breadboard power converter unit developed at OAC.

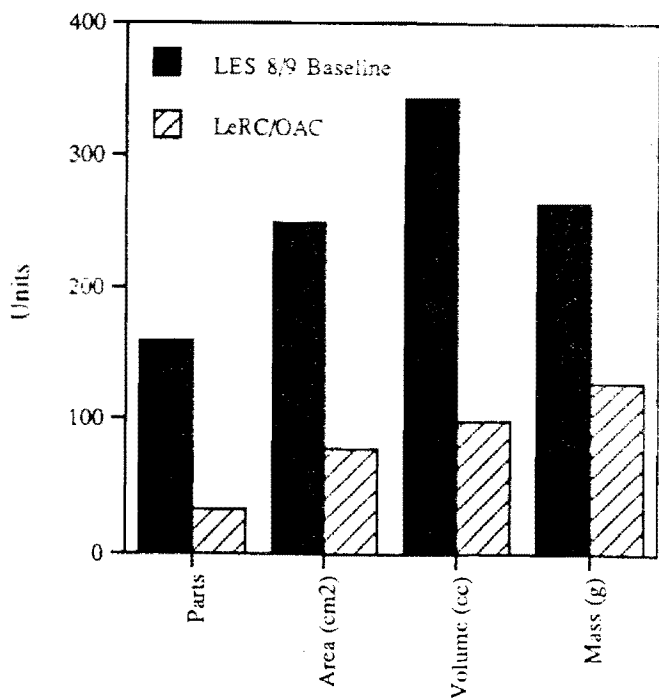

Figure 7 - Demonstrated improvements in PPT power converter system.

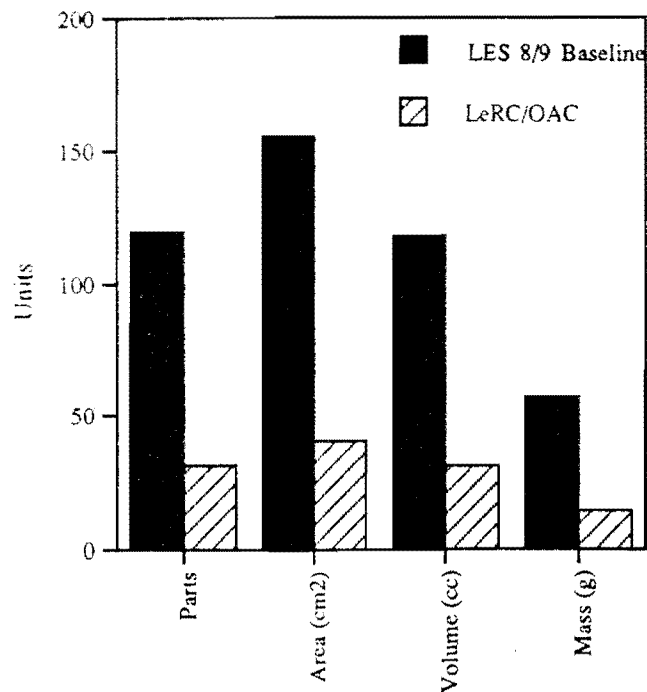

Figure 9 - Demonstrated improvements in Logic/Telemetry system as compared to the LES 8/9 baseline system.

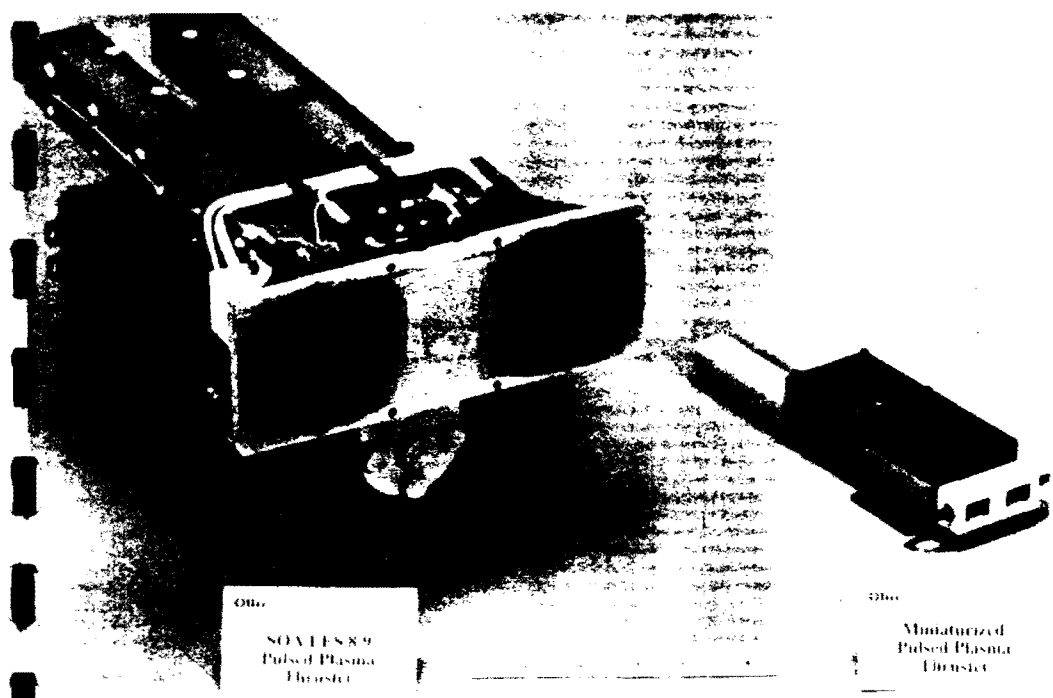

Figure 10 - Photograph of an advanced miniaturized PPT mock-up next to the LES 8/9 baseline system.