

THE SCOUT LAUNCH VEHICLE SYSTEM

Pamela A. Tanck* and James L. Williams**

ABSTRACT

SCOUT, a four-stage, solid-rocket launch vehicle originally developed by LTV Missiles and Electronics Group, is completing its third decade of service. NASA-Langley started the program in 1958 with the intent of providing a simple, low-cost, reliable launch vehicle for orbital, probe and re-entry missions. On July 1, 1960, the first SCOUT vehicle was launched. Since SCOUT became operational in 1963, there have been 88 launches of which 84 were successful, representing a reliability record of 95.5 percent successful flights. In addition, over the past 20 years the reliability rate is an excellent 98.2 percent.

The role of the SCOUT launch vehicle has varied from Earth and space science missions to engineering experiments in communications, re-entry materials, and spacecraft technology, to navigation aids. Major customers have been NASA, the Department of Defense, and the European Space Agency, as well as cooperative programs with Italy, Great Britain, Germany, France, and the Netherlands.

SCOUT launch capability has been increased throughout the life of the program. In 1960, 55 kg could be placed into a 555 km circular orbit. Today, SCOUT can place 219 kg in a 555 km circular, equatorial orbit. Current plans are to increase future capability to 450 kg for the same orbit. A joint development program with SNIA BPD of Italy and LTV Missiles and Electronics Group for this purpose is under consideration. Increased capability would be achieved by attaching two of SNIA BPD's solid-rocket boosters to the current vehicle and replacing its upper stage with a SNIA BPD Mage 2 solid-rocket motor.

INTRODUCTION

The National Aeronautics and Space Administration and LTV Missiles and Electronics Group (which was then Chance Vought Aircraft Co.) designed and developed SCOUT in the late 1950's. The first flight of SCOUT was in 1960, and the first orbital launch was the Explorer-9 satellite in 1961. SCOUT has performed a total of 111 missions to date.

The objectives of the SCOUT Program were to develop a simple, reliable, and inexpensive research/applications vehicle for orbital, re-entry and probe missions. The program achieved these goals by a wide margin. Since becoming operational in 1963, SCOUT has performed 88 missions of various types with a remarkable 95.5 percent success rate. Over the past 20 years, since 1968, SCOUT has performed 56 missions with a success rate of 98.2 percent.

SCOUT has launched a variety of satellites, ranging from applications missions to Earth and space science experiments. Figure 1 lists some of the satellite contributions made by SCOUT missions. These missions involved payloads from NASA, the Department of Defense, and several foreign nations (including France, Germany, Italy, the Netherlands, and the United Kingdom). Figure 2 shows the users and the number of missions for the 111 SCOUT launches.

* NAVIGATION	TRANSIT, TRANSAT, NOVA
* ASTRONOMY	ASTRO NETHERLAND SATELLITE SMALL ASTRONOMY SATELLITES, UK-5, UK-6 (ENGLAND)
* COMMUNICATIONS RESEARCH	ESRO-4, FR-1 (FRANCE) SMALL SCIENTIFIC SATELLITE A RADIATION ATTENUATION MEASUREMENT-CA, CB, CC
* METEOROLOGY	DUAL AIR DENSITY EXPLORER, AEROS-A,B (GERMANY) SAN MARCO A,B,C,C-2 (ITALY), CAS-A (FRANCE)
* GEODESY	SEQUENTIAL CORRELATION OF RANGE (SECOR-5) BEACON EXPLORER -B,C
* METEOROID ENVIRONMENT	MICROMETEOROID MEASUREMENT SATELLITE-A,B,C METEOROID TECHNOLOGY SATELLITE
* RE-ENTRY MATERIALS	RE-ENTRY -4, RE-ENTRY -E,F, RFD -1
* BIOLOGY	ORBITING FROG OTOLITH, OV4-3
* SPACECRAFT TECHNOLOGY	X-4 (ENGLAND), SERT-1
* APPLICATION	HEAT CAPACITY MAPPING MISSION STRATOSPHERIC AEROSOL AND GAS EXPERIMENT MAGNETIC FIELD SATELLITE

* Senior Vehicle Performance Engineer, LTV Missiles and Electronics Group; Member, AIAA

**Technical Program Manager, LTV Missiles and Electronics Group; Associate Fellow, AIAA

Figure 1: Satellite Contributions

User	Number of Missions
DoD	47
NASA	39
International	23
AEC	2

Figure 2: SCOUT Users

The cost of a SCOUT launch is currently in the \$11 - 12 Million range. The cost of using SCOUT is more favorable when indirect cost factors such as simpler mission integration and flexible, dedicated launches are considered.

GROWTH HISTORY

SCOUT's capability and versatility have increased over the past thirty years, as shown in Figure 3. Payload weight capability has increased by over a factor of 3. This has been accomplished primarily through improvements in the solid rocket motors. In addition, the heatshield diameter has been increased, increasing payload volume capability by a factor of 12. Another factor which has increased SCOUT's versatility is the addition of two launch sites to the original Wallops Island, Virginia launch complex. The site at Vandenberg Air Force Base, California provides polar orbit capability. The San Marco launch site, which is operated by the Italian government, is off the east coast of Kenya, Africa. This site provides equatorial orbit capability and increases payload weight capability by taking advantage of the greater rotational velocity of the Earth at the equator.

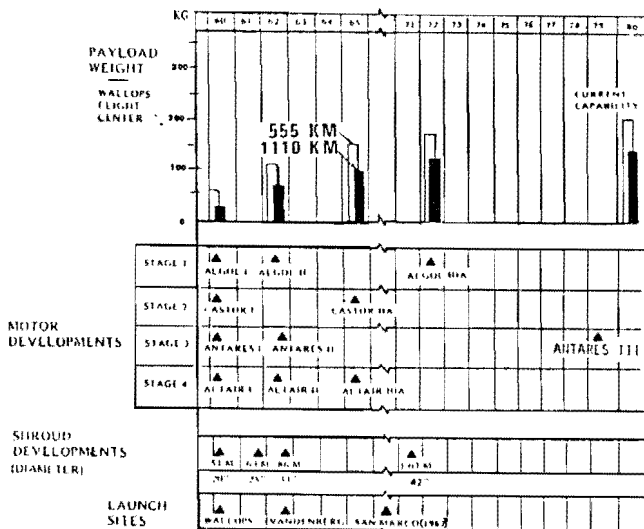

Figure 3: SCOUT Growth History

CONFIGURATION

Basic dimensions of the SCOUT G-1 configuration are given in Figure 4. The vehicle weighs 21,543 kg, is 23 m long, and is 1.14 m in diameter at the base. Characteristics of the motors and flight control systems of the four stages are given in Figure 5. A typical mission profile showing the motor staging events is shown in Figure 6.

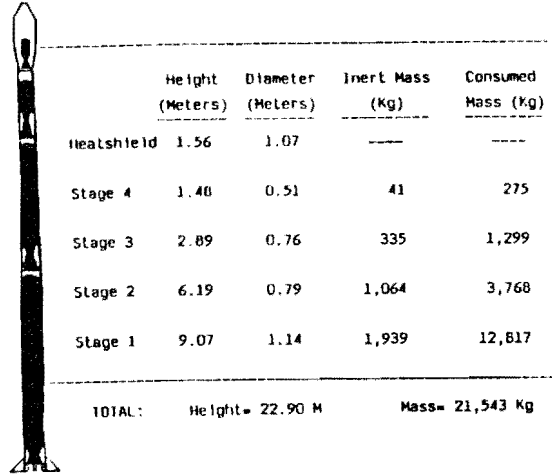

Figure 4: Basic Dimensions

	Stage 1	Stage 2	Stage 3	Stage 4
Flight Control System	Aerodynamic Fin Tips and Jet Vanes	Reaction Control Motors	Reaction Control Motors	Spin Stabilized
Motor Designation	ALGOL IIIA	CASTOR IIA	ANTARES IIIA	ALTAIR IIIA
Manufacturer	UTC	MORTON-THIOKOL	MORTON-THIOKOL	MORTON-THIOKOL
Total Vacuum Impulse (N-sec)	32,385,209	10,254,867	3,736,200	772,400
Average Web Vacuum Thrust (Newtons)	467,164	284,316	83,100	25,390
Propellants	PBAN	CTPE	HTPB	CTPE
Maximum Chamber Pressure (N/CM ² *1000)	6.688	5.509	5.743	5.674
Expansion Ratio	6.5	21.2	56.8	50.3
Web Burn Time (sec)	56.1	35.3	44.0	29.3

Figure 5: Motor data and Flight Control Systems

Major assemblies on the SCOUT vehicle are given in Figure 7. As shown in Figure 7, the base section "A" and transition sections "B" and "C" house the control systems for stages 1, 2, and 3, respectively. The transition section "D" contains the fourth stage spin-up, separation, and guidance systems. The "E" transition section is used to join the spacecraft to the fourth stage. There are

three adapter section configurations available to accommodate different spacecraft requirements, or the spacecraft can provide its own adapter section. The three adapters may be used with or without the separation systems. Three heatshields are available depending on payload volume requirements. The largest heatshield has a 1.07 meter diameter, the two smaller heatshields have 0.86 meter diameters.

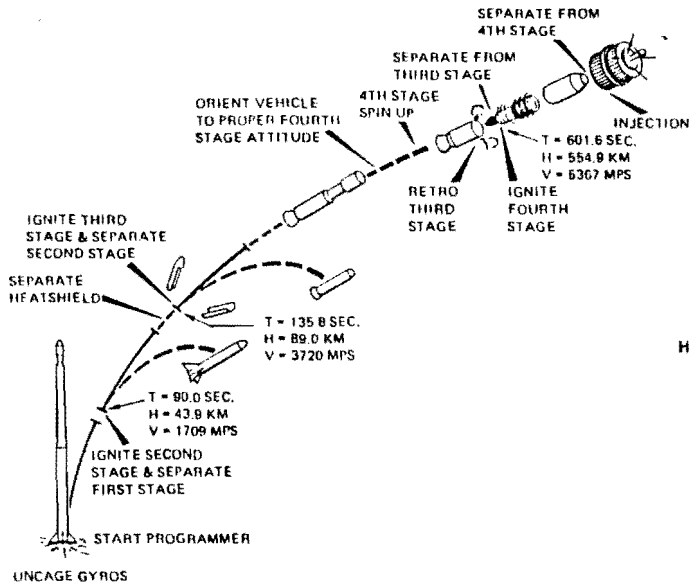

Figure 6: Typical Mission Profile

FLIGHT CONTROL SYSTEMS

The guidance and control system provides an attitude reference and the resultant control signals and forces necessary for stabilization of the vehicle in its three orthogonal axes corresponding to pitch, roll, and yaw. The inertial system uses "stapped-down" miniature integrating gyros, as well as three rate gyros.

In the lift-off configuration the vehicle is aerodynamically stable. First-stage control is provided by a combination of jet vanes in the solid

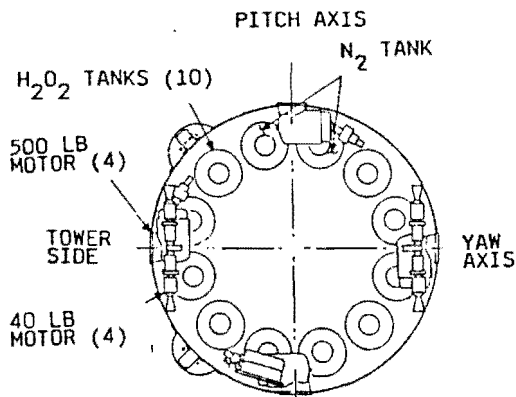

Figure 8: Second Stage Control System

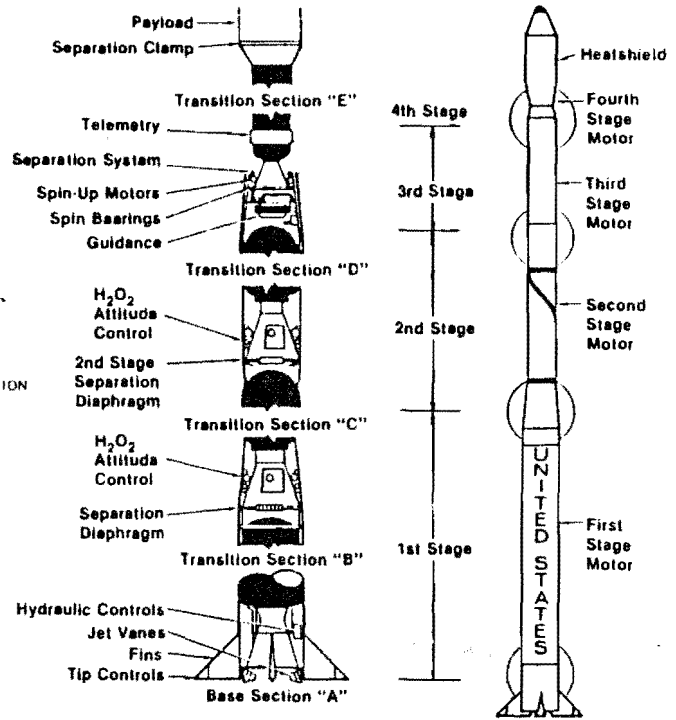

Figure 7: Major Assemblies

rocket motor exhaust plume and aerodynamic tip control surfaces both of which are attached to a common shaft which is operated by a hydraulic actuator. The jet vanes provide most of the control during thrusting; after burnout, the aerodynamic surfaces provide all of the control.

Control of the second and third stages is conceptually the same as for the first stage, but the control forces and moments are provided by hydrogen peroxide reaction jet motors. These jets are placed so that moments are generated around each of the control axes; pitch, roll, and yaw. During third stage coast, the coast controls are activated with greatly reduced thrust to conserve control system fuel. The reaction control thrust level and arrangement, and location of the hydrogen peroxide monopropellant tankage for second and third stages are shown in Figure 8 and 9, respectively.

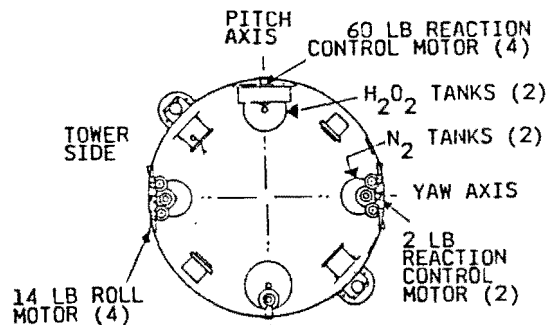

Figure 9: Third Stage Control System

The fourth stage, including the payload, is spin stabilized. Four small solid rocket motors spin-up the fourth stage as shown in Figure 10. Spin-up begins 2 seconds prior to third stage separation and 6 seconds prior to fourth stage motor ignition. De-spin devices are used after fourth stage burnout, if required by the spacecraft.

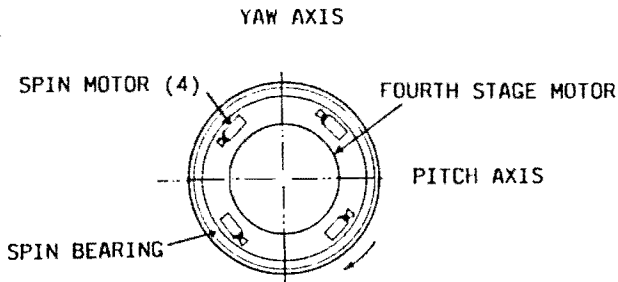

Figure 10: Fourth Spin-Up System

ORBITAL PERFORMANCE CAPABILITY

Orbital performance capability of the G-1 SCOUT configuration is shown in Figure 11 for each of the three launch sites. A 219 kg payload can be placed in a 555 km circular equatorial orbit from the San Marco platform, or a 165 kg payload can be placed into a 555 km circular polar orbit from Vandenberg Air Force Base. The three launch sites and their respective launch azimuth capabilities are shown in Figure 12. The velocity and acceleration histories for a nominal trajectory are given in Figure 13 and 14, respectively.

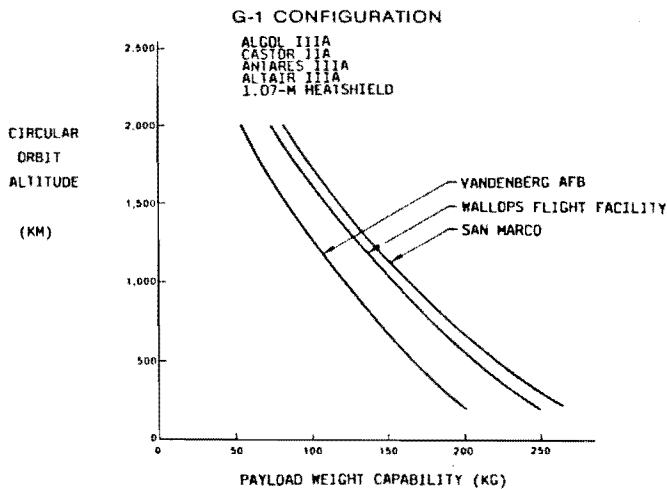

Figure 11: Orbital Performance Capability

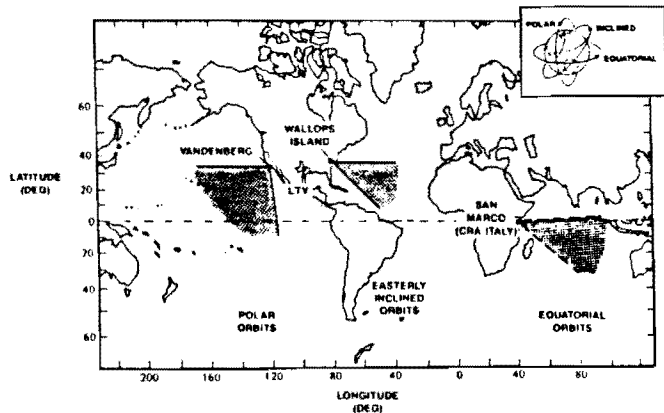

Figure 12: Launch Sites

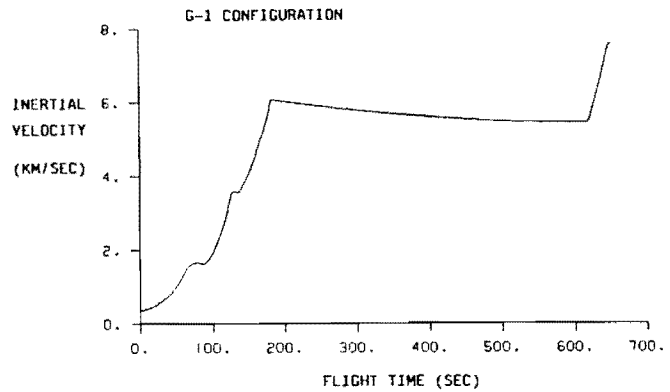

Figure 13: Typical Velocity Profile

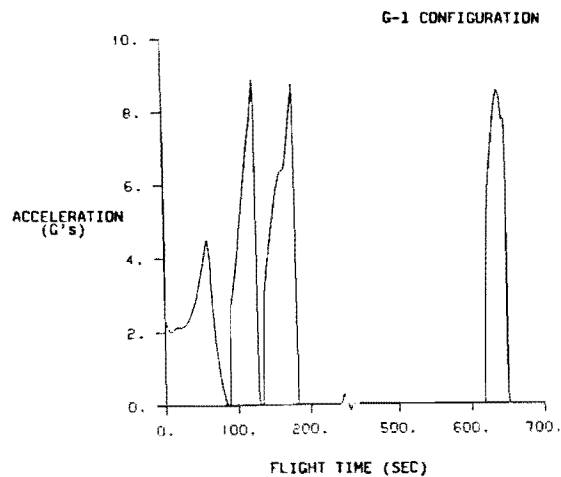

Figure 14: Typical Acceleration Profile

LAUNCH SUPPORT FACILITIES AND EQUIPMENT

Launch support equipment at the three launch sites is functionally identical. The launch complex consists of a launcher, movable shelter and blockhouse. The launcher is used in the horizontal position for launch preparations. The movable shelter provides protection and environmental control while the vehicle is in this position. The shelter is rolled away from the vehicle for launch; the vehicle is raised to the vertical position and rotated to the proper launch azimuth. The launcher's rotating base provides azimuth control up to 140 degrees, which exceeds the requirements for all three launch sites. The blockhouse provides the remote control, monitoring and check-out equipment used during launch operations.

Check-out and test equipment for the launch sites at Wallops Flight Facility, Virginia, and Vandenberg Air Force Base, California include the Assembly Building and the Dynamic Balancing Facility. The Assembly Building is used for motor check-out, vehicle assembly, build-up and systems check-out. The Dynamic Balance Facility is used to spin-balance the fourth stage motor and payload.

RELIABILITY

A record of high reliability is one of the most significant assets of the SCOUT program. As shown in Figure 15, SCOUT once had a record string of 37 consecutive successful flights. At present SCOUT has had 18 consecutive successes. There has been one failure in the last 56 launches.

This reliability record is particularly remarkable considering that it was achieved with a low launch rate and an aging inventory. Much attention has been focused on ensuring the quality and reliability of hardware and systems. These factors contribute to higher launch costs because of the number of people required to verify the reliability of parts and systems. Attention to quality has paid off for the SCOUT Program in terms of the high reliability achieved.

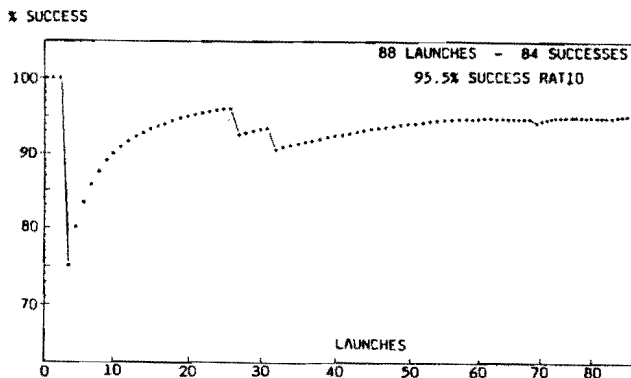

Figure 15: Success Ratio

FUTURE PLANS

Studies are underway to develop an advanced version of SCOUT, termed the SCOUT 2, which would approximately double the payload weight capability of the current system. As shown in Figure 16, two solid-rocket motors would be added to the standard G-1 SCOUT configuration as strap-ons, and the fourth stage would be replaced with a SNIA BPD Mage 2 motor. This would increase the payload capability of SCOUT, from 219 kg to 450 kg for a 555 km equatorial orbit. This is a proposed joint development program with SNIA BPD of Italy and LTV Missiles and Electronics Group.

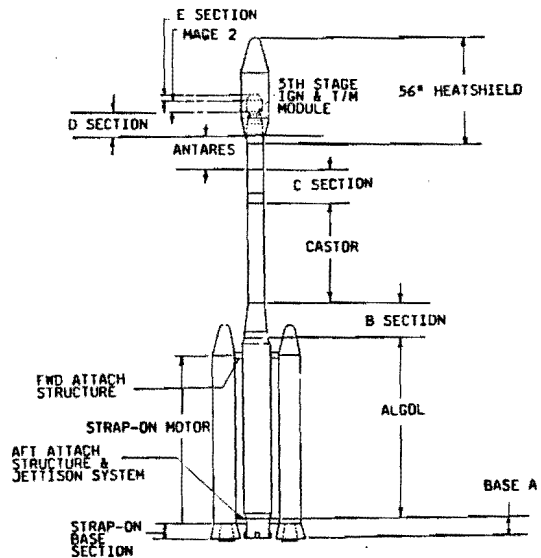

Figure 16: SCOUT 2 Configuration

Reference
 SCOUT Planning Guide, LTV Missiles and Electronics Group, Missiles Division, P.O. Box 650003, Dallas, TX 75265-0003, May 1987.