

The Inexpensive Injection of Mini-Satellites into GEO

G. M. Webb(1), Fadeev A. (2), Pestmal N. (1)

Commercial Space Technologies, Ltd., 67 Shakespeare Rd, Hanwell, London W7 1LU, UK,

Tel: +44 020 8840 1082 (UK), E-mail: cst@commercialspace.co.uk

(2) Centre for Ground Space Infrastructure Operations, 129857, Moscow 42, Schepkin street

Abstract

CST has undertaken several studies of the methods available for the launch of GEMINI-1, a 400 kg test satellite being built by Surrey Satellite Technologies Ltd. (SSTL) in collaboration with Nigeria, for the BNSC which have included in their MOSAIC UK small satellite programme.

The results of these studies with cost comparisons will be presented in the paper. It will be shown that the cost/kg of placing a mini satellite into GEO need not be any more than that for larger satellites and in some special circumstances may be significantly cheaper. This interesting result could have far reaching consequences for the communication marketplace and technologies. It could also encourage research and development, innovation and independence.

1. Introduction

In recent years the capabilities of small satellites have improved to such an extent that GEO communication satellite payloads of less than 500 kg are now being seriously studied and developed world-wide. To launch such satellites inexpensively, i.e. at or below the cost/kg of 'conventional' large GEO comsats, unless this is done in a large cluster, is apparently impossible. New players are looking to using GEO mini-satellites for various reasons. In the field of communications, some of these reasons are:

- The high level entry costs for using 'conventional' large satellites, which are getting larger anyway
- Economical experimentation and technology demonstration
- Stop-gap regulatory compliance, phased roll-out of capability at a particular slot
- Tests of markets or small 'niche' markets
- For developing countries: independence and prestige with improvement of technology base.

The last factor is addressed for all classes and orbits of small satellites (from 6 kg to 400 kg so far), particularly remote sensing, by Surrey Satellite Technology Ltd (SSTL) for which CST procures launches in the Former Soviet Union (FSU) at the economical prices which are essential for most small satellite projects. The FSU remains the best overall source of launches for small satellites [1].

Until standard definitions are universally adopted CST uses the following: picosat<10 kg, microsat<100 kg, minisat<500 kg, small satellite<1000 kg.

2. Methods

There are at least four distinct potential methods available uniquely to mini satellites which are relatively inexpensive to use. These are:

1. Dedicated Small Launchers such as Soyuz+Fregat, Tsyklon-4 (if this is produced), Angara [1, 2] and Athena 2 (with PAMs) or converted missiles with additional stages.

2. Ion Propulsion
Khrunichev is developing a satellite bus with ion propulsion capacity capable of reaching GEO from a ROKOT launch called 'Yacht'.

3. Cluster Launching
Any of the extant launchers could be adapted to do this. Proton already does cluster launchers to HEO of GLONASS satellites and new EXPRESS buses are being developed which will be cluster launched to GEO.

4. Piggy-backing
Ariane-5 can do this to GTO but this orbit is not suitable for very small satellites for which the extra propulsion burden to get to GEO is proportionately greater. Proton can piggy-back a satellite in the mini-satellite class directly into GEO at economical cost.

CST has made an agreement with the Russian government body CGSI (Centre for Ground Space Infrastructure Operations) to enable it to arrange the launch of mini-satellites of the GEMINI class to GEO using methods 1, 3 and 4.

Since method 2 is actually a way of producing a small dedicated GEO launcher from a converted missile it will be dealt with, with method 1, under the title of small dedicated launchers, below.

3. Piggy Back and Cluster Launches

Methods 3 and 4 have been described in [1] for LEO satellites. For GEO/GTO missions, opportunities are rare and sometimes difficult to arrange, but the potential savings make the exercise worthwhile. Direct insertion into GEO with non-FSU launchers is rare since nearly all insert satellites into GTO only (and the large satellites have the propulsion capability to 'do the rest') and the FSU method of using the satellites as platforms [2] is impossible due to insurance/risk problems on commercial missions and the satellite construction methods. Perhaps a crucial factor is that in the rest of the world (ROW) outside the FSU it is traditional to use every available gram of launcher capacity, e.g. by loading extra propellant on to the satellite to increase its available lifetime, thus leaving no space at all for 'parasitic' payloads.

Because of the consequences of Stalin paranoia (not because of the lack of any innate ability) electronics in the FSU was retarded. Thus all FSU satellite designs had much lower lifetimes than that usual in the 'West'. Launchers, however, being related to missile technology were well advanced, (it is no coincidence that US launching companies are buying Russian/Ukrainian launcher technology) designed for long production runs and consequently cheap. In addition to this (from a land of theoretical masters) a launcher is regarded as just part of an overall system and it is this, therefore, which is optimally designed. As a consequence, horizontal integration and efficient pad design leads to great efficiency of use.

Therefore, Soviet launchers were often launched with very light payloads compared to their real capacity, it being more economical to off-load propellant than build payloads of non-standard design. Even now, after 12 years, Russia and Ukraine inherit the shadows of this (not bad) philosophy.

Thus piggy-backing is possible and is likely to remain possible on FSU GEO national launching missions, i.e. for Proton, Zenit-3 from Baikonur, Soyuz-Fregat, Angara, etc.

Piggy-backing directly from an attachment on 'Western' satellites is impossible because of the dedicated (and delicate) nature of their design as well as the other factors mentioned above. However, because of the above and other factors affecting their design also mentioned, FSU satellites are more 'agricultural' (British Aerospace description on first examining one) and the deployment of small satellites direct from their structure has actually been the commonest method used in the FSU for piggy-backing (as opposed to 'cluster launching' – see later). CST's first piggy-back launch arrangement in 1995 for Surrey Satellite Technology Ltd. was, in fact, direct from the Ukrainian radar ocean

surveillance satellite 'Sich'. [CST and SSTL were impressed that several 'take-off' points were offered from the structure of 'Sich'.]

In spite of all of the above, it is unlikely that piggy-back insertions to GEO will be available directly from an FSU main satellite as these are rapidly improving in both structural efficiency, lifetimes and performance. However, by attaching to and deploying from the relevant upper stage such as Blok-D variants, Breeze variants or, possibly, Fregat variants, piggy-backing to GEO is possible and economical with the additional advantage of independent deployment once the main satellite is placed. A proposal for this method of deployment for GEMINI-1 is shown in Figure 1.

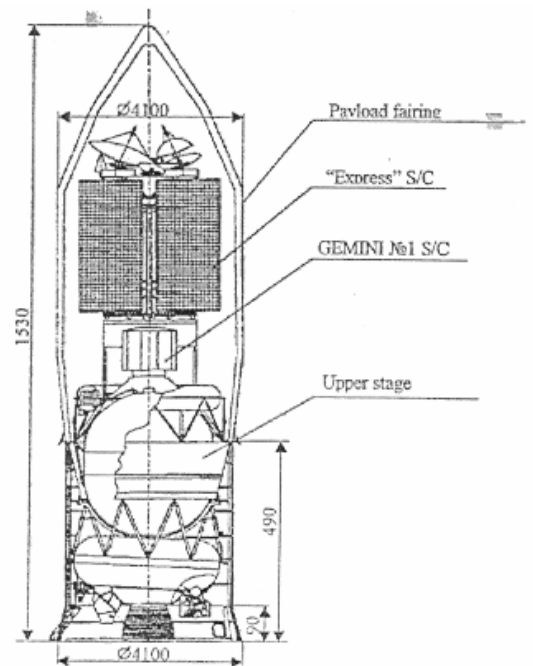

Fig. 1. Upper stage unit with S/C and upper stage arrangement for piggy-back launch (CST).

In piggy-backing, the main criterion is that the piggy-back satellite does not interfere with, or risk in any way, the primary payload. Also, in the purest case, it must comply with any delays, cancellations, in timescale or orbit, of the primary satellite. While dedicated launches are the alternative at a price, cluster launches may present a more effective solution. However, the satellites are not always 'of equal rank', with one small satellite being prime. Dnepr and other small launcher LEO missions tend to follow this pattern. However, most HEO and potential GEO cluster launches would seem to have a 'pure equality'. An example of this is a proposed alternative cluster launch method for GEMINI-1 which is shown in Figure 2.

Piggy-backing in various guises has existed in the Soviet Union from 1972 when the French SRET-1 was injected by the 'Molniya' launcher. Interestingly,

in the SU and until recently in FSU no payloads have been separated directly from the top stage of a launch vehicle. All were attached to and separated from the various satellites which were the primary payloads. A popular choice for sun-synchronous missions was the 'Resource' satellite launched with a Zenit-2 from Baikonur, always with plenty of spare mass capability [1, 2].

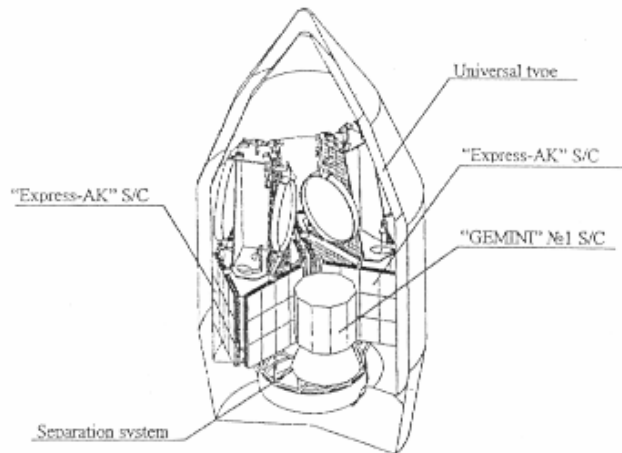

Fig. 2. "Packed" arrangement of S/C inside upper unit of Proton for a cluster launch (CST).

Meanwhile, in the 'West', NASA has occasionally offered 'free' piggy-backs for guests (e.g. SSTL's first two missions), but perhaps the most rational and significant development was the ASAP (Ariane Secondary Auxiliary Payload) platform from Arianespace (with some encouragement from SSTL who launched their next satellites with it to SSO with SPOT missions). This, as its name describes, allows piggy-backs to be launched without interference with the main payload. The ASAP facility was carried over from Ariane-4 to Ariane-5 and the maximum dimensions and mass allowed (120 kg) has given rise to a new 'standard' mini-satellite type and several projects are underway (in Europe at least) for launching satellites of this class to GTO using an ASAP platform on Ariane-5.

However, there is a fairly obvious problem with placing a 120 kg satellite in GEO via GTO, which is propulsion/propellant mass. In fact, true mini satellites in GEO are pushing the design margin in several directions, not just mass and power requirements/solar panel size. [Russian projects Dialogue, Ruslan-MM and Express AK are, as a consequence in the 'small' rather than 'mini' class. It remains to be seen whether small communication satellites of 120 kg launched via GTO are viable at all. Aware of this, CST is attempting to produce launch solutions to GEO by piggy-back (400 kg max) or cluster (800 kg max) methods. Certainly the problems for the 120 kg class could be considerably eased if they could be launched to GEO in pairs or triplets (probably the most economic option).

The target price for CST's launch solutions is \$20,000 per kg, but this specific cost will rise for non-optimum masses or sizes.

4. Dedicated Small Launchers

These would seem to be thin on the ground in the West with the Athena-2 with PAMs being a possible candidate (price to be established), but in the FSU there are at least 6 possible candidates in the near term (prices also to be established).

Soyuz+Fregat

At around \$30 m US from Starsem for 2.0 + tonnes to GTO from Kourou this launcher is a little on the large and therefore expensive side for small satellites, but may be within economical range for minisats as part of shared or clustered payloads. First Starsem launch from Kourou is currently scheduled for 2006.

In certain circumstances shared launches with Russian national missions may be possible from Baikonur. It is difficult at this stage to say which will be better from an auxiliary payload point of view.

Tsyklon 4

A project by Ukrainian/Italian/Brazilian organisations is persevering (limited mainly by funding difficulties) to establish a launch base for Tsyklon-4 at the Alcantara range which is very close to the equator. If successful, the result could be a very credible economical (around \$20 million US) light GEO launcher. There are many ways in which the Tsyklon-3, a very reliable and well proven launcher, could be stretched. The new launcher (Figure 3) will have increased performance of the engines, a modern control system and the head fairing with an increased volume of the payload compartment. It will provide the possibility to inject a satellite or a group of satellites of up to 5500 kg to an equatorial orbit of 500 km or a satellite of 1800 kg to GTO. The range of launch azimuth will be from 0 to 115°. 'Tsyklon-4' differs from the previous 'Tsyklon-3' as follows:

- a new third stage will have treble the amount of propellant and will have a high weight perfection that will increase the power of the launcher and reduce the longitudinal g-load down to 6g,
- multiple operation of the modernised propulsion plant of the third stage (up to 3...5 starts) will provide new possibilities, including group launches.
- a new high-precision control system with GPS navigation will be used,
- a new head fairing with an increased payload volume and satellite environment control will be used.



Fig. 3. The Tsyklon-4 launch vehicle (artist impression, *Yuzhnoye*).

Angara Variants

The 'Angara' name (the name of a Siberian River) was given initially to the future Russian heavy launcher for which development the Rosaviakosmos announced a competition in 1994. This competition was won by the Khrunichev Space Centre and this company began to develop their own project for a two-staged heavy launch vehicle having no opportunities to derive any small launcher from it. However, in 1997, when the 'Angara' project was at the stage of Critical Design Review (CDR), the Khrunichev's management decided to begin the development of quite a new concept of 'Angara' – a modular one. One of the reasons was an opportunity to create a whole family of various classes of launchers instead of only a single heavy launch vehicle. Besides the modular heavy 'Angara', significant attention was given to two versions of a

small launcher, which received the 'Angara-1' designation.

The two-staged 'Angara-1' was developed in two versions, 'Angara-1.1' and 'Angara-1.2', which differed in upper (second) stages. The first stage of both versions should be a single module of the heavy 'Angara' first stage (it could be used either as a strap-on booster or core module in the other versions of this heavy launcher). The module should use the oxygen/kerosene RD-191 rocket engine, a one-chambered derivative of the 'Energomash's' four-chambered RD-170/171.

The strength of the Angara project lies in this Unified Rocket Module, URM. With it, in a 'pick-and-mix' variety of options using a selection of well tried and proven technology for top-stages, the Angara family will complete very effectively (on a 'level playing

field' it would be fatally) with everything from Rokot (Angara 1.1) to Ariane 5 enhanced (Angara 5), Figure 4. There are even completely reusable (not Shuttle style SRM) options developed for very good reasons, the chief being political/environmental rather than financial. An engineering pre-production prototype (not a wooden mock-up) was exhibited at the Le Bourget air show in 1991, Figure 5.

The only thing that stops Khrunichev sweeping the world with all of this is their dire financial position, the associated poor state of the GEO COMSAT

launching market and the usual Byzantine Russian politics and company practice. However, the relevance of the Angara family to GEO mini and small satellite launching should be obvious. For example Angara-3 is equivalent to Zenit-3, could be cheaper than, and may even be able to operate from, Zenit launch pads!

Of all six launchers being discussed in this section, only Angara and perhaps Soyuz offer environmental cleanliness.

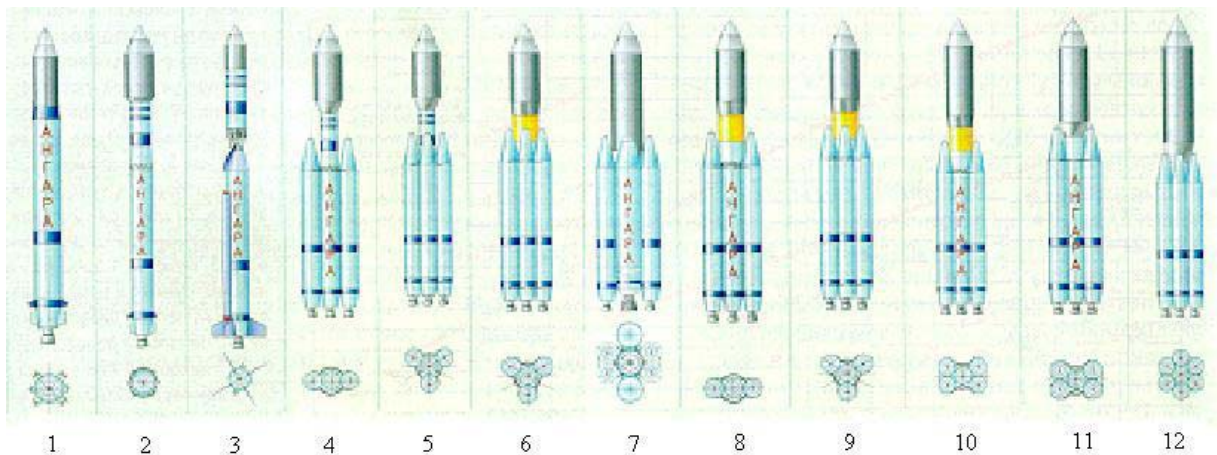

Fig. 4. The 'Angara' family of launchers

1 – 'Angara-1.1', 2 – 'Angara-1.2', 3 – 'Angara-1VA', 4 – 'Angara-3 I', 5 – 'Angara-4 I', 6 – 'Angara-5 I', 7 – 'Angara-4E', 8 – 'Angara-3SPG', 9 – 'Angara-4SPG', 10 – 'Angara-5SPG', 11 – 'Angara-5', 12 – 'Angara-7' (Khrunichev)



Fig. 5. The full-scale engineering mock-up of the 'Baikal' reusable fly-back booster at Le-Bourget in 2001 (Khrunichev photo).

The last 3 dedicated GEO launchers are

- all converted missiles ‘with tricks’
- all are close to realisation
- all could offer a more ‘tailored’ option for minisatellites at prices which may go below \$20 m dollars US/launch
- all are dependent on the remaining stocks of missiles and their condition
- all are environmentally problematical and all will probably operate only from within the FSU

Dnepr+Stages

Dnepr [1, 2] based on the SS-18, is larger than Rokot and Strela which are based on SS-19. In its basic form it is cheaper than Rokot, which needs an especially constructed third stage (Breeze) to give it its

admittedly very flexible performance. Dnepr outperforms Strela, a similarly ‘straight’ form of the SS-19 by a considerable margin.

With the addition of a Self-Contained Booster Stage (SBS), probably to be derived from SS-24 technology, Kosmotras (the marketing company) claim a capability of 300 kg to GEO. A reproduction of a recent brochure showing the SBS appears in Figure 6. Thus the Dnepr+stage(s) become a most interesting contender amongst the GEO launching alternatives. CST has been informed by Kosmotras that the SBS is proceeding for a particular contract, so prices and availability timescales are awaited with interest.

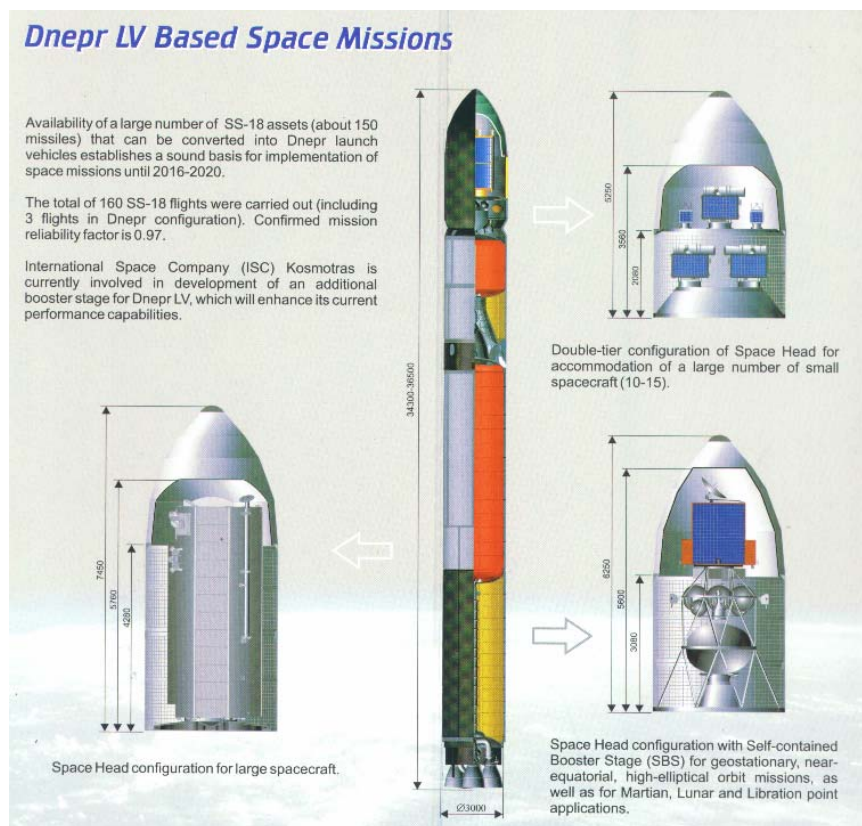

Fig. 6. Dnepr payload accommodation showing SBS – (Kosmotras brochure).

Rokot+stage+ion propulsion

Under the auspices of ‘Eurockot’ Rokot has now begun a programme of LEO commercial launches for ‘western’ small satellites. However, a completely internal (originally at least) programme of Khrunichev is attempting to develop a satellite bus called Yacht equipped with considerable ion propulsion capability with which to launch a plethora of proposed variants of two satellites also similarly equipped, ‘Monitor’ and ‘Dialogue’. Monitor is an LEO remote sensing satellite for which the ion

propulsion is needed for tracking control (an engineering dummy was launched in June 2003 with a variety of microsattellites as a cluster) and Dialogue (described below) is a GEO small COMSAT for which ion propulsion is needed for both insertion and station-keeping.

Khrunichev was hoping to surprise the world with an impressively cheap Rokot+Yacht with ion propulsion direct insertion of ‘Dialogue’ into GEO. Re-assessments proved this to be impossible and now an extra stage must be added. In the meantime, a pair of

Dialogues are planned to be cluster-launched on Proton for tests.

This method remains of serious interest and a variant of Dialogue is being built (whether 'ion' launched or not) as one of the contenders tendered to fulfil the Intersputnik-100M small satellite in GEO requirement issued in 2000 (see below).

Strela+stage(s)+ion propulsion

Strela would seem to be the least likely choice since, not only has it not flown but it comprises the 'bare' missile without the 'Breeze' upper stage. Its derivation, Figure 7, arises because NPO-M (Mashinostroyeniya) its sponsoring company was the central controlling company of the Chelomei empire of which Khrunichev was simply a part and now shares the rights to market or use the SS-19.

The Strela will be test launched in the coming year from Baikonur, although launch facilities enabling SS orbits are being prepared at Svobodny. NPO-M needs Strela anyway to launch 'Condor', a remote sensing (mapping) satellite which is part of a 'turn-key' contract for the supply of cruise missiles (another NPO-M product). NPO-M may also have to supply a small GEO satellite which will be similar to the Ruslan-MM and it is also tendering (competitively with Khrunichev and NPO-PM, Krasnoyarsk, Siberia) for the Intersputnik-100M contract.

Thus, the motive for NPO-M to devise a method to launch small satellites into GEO is clear, although the precise details of the system that they are developing have not yet been released.

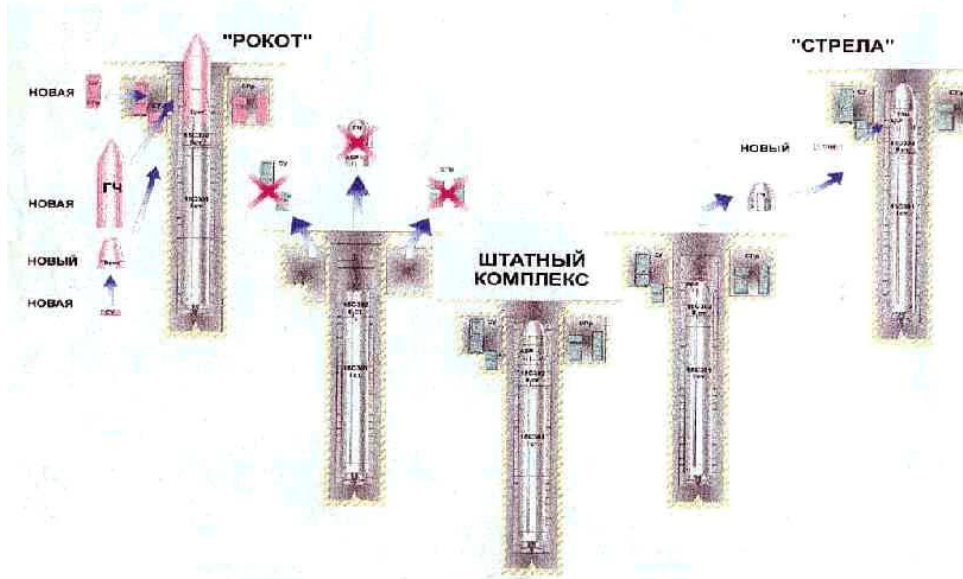

Fig. 7. The evolution of the 'Rockot' ('POKOT') and 'Strela' from the SS-19 (NPO-M).

5. Mini and Small Satellite GEO Projects

A brief description of four real mini/small GEO communication satellite projects, while not within the exact remit of a paper describing the methods of getting there, is included because designers or potential operators of such systems may be interested and encouraged to know that firm, established projects for real satellites exist. No doubt the processes of evolution will establish the final configuration that such satellites will take in the various mass classes, as it has done for 'normal' large GEO satellites. Even now, mass classes of around 120, 400 and 800 kg seem to be emerging in conjunction with the distinctly different launch solutions of paired/dedicated, piggy-back and cluster.

Gemini (GEostationary MINISatellite)

This test satellite series is being developed by SSTL. Initial funding was provided by the British government (BNSC) MOSAIC programme to sponsor small satellite initiatives (Topsat and DMC were others). However, the Nigerian Federal Ministry of Science and Technology is also providing some funding for GEMINI-1, shown in Figure 8, to be launched in 2005 and SSTL has won a tender to use the GEMINI bus as a test-bed for the GALILEO European navigation satellite system. Thus the project is well founded and follow-ons, GEMINI-2, 3, etc. are planned.

To enable a wide variety of launch alternatives, the mass of GEMINI-1 is capped at 400 kg. Nevertheless it carries 6 transponders and has a planned life of at least 7 years. The launch, probably piggy-back with

an Express satellite is the subject of an inter-agency agreement between the BNSC and Rosaviasmos and being arranged by CST in conjunction with CGSI (Centre for Ground Space Infrastructure Operations) and SSTL. Further information can be obtained from

SSTL (who attend the AIAA/USU small satellite conferences regularly), or from the BNSC.

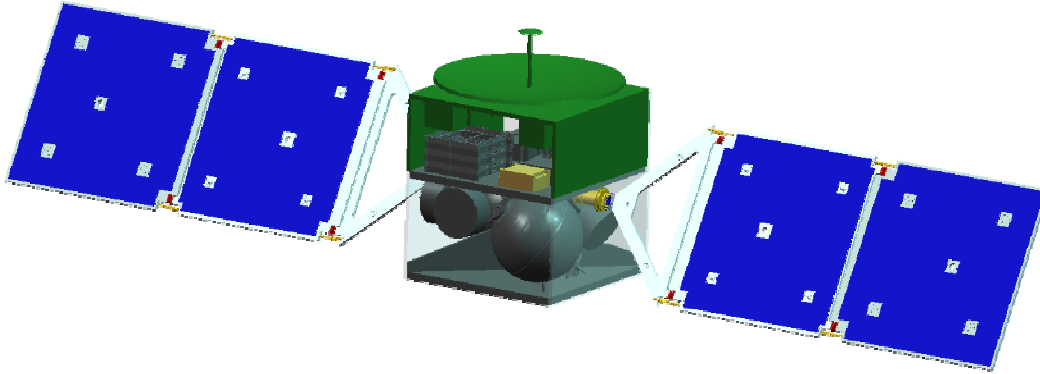

Fig. 8. GEMINI-1.

The next 3 satellite projects

- are all Russian
- all, though delayed, stand a reasonable chance of being flown
- all are being developed by reputable organisations for real reasons
- are all heavily influenced by a tender for (a large but indeterminate) number of small GEO communication satellites issued in 2000 by Intersputnik, the Intersputnik-100M project

The Intersputnik –100M project

The details of this project were contained in the ‘Intersputnik’ company’s brief announcement, which was published in 2001 in [3] and is cited below:

‘Intersputnik has published additional details of its 100M Project, which aims to develop a global fleet of small telecommunication satellites for domestic, regional and international communications and broadcasting networks. Information on the future use of Intersputnik’s 15 geostationary slots as well as plans for bi-directional Ku-/S-band Internet services under the project have also been revealed.

Under current plans, four of the 15 slots would be used as ‘parking slots’ from which satellites can be dispatched to ‘operational slots’ on demand. The two western parking slots are 32.5 degrees and 23 degrees West, serving the following five operational slots: 97, 83, 16, 6, and 3 degrees West. In the East, 64.5 and 67.5 degrees East have been designated as parking slots. The six operational slots are 17, 27, 59.5, 75, 114.5 and 153.5 degrees East.

Intersputnik launched the project in November (see CST note below) to develop a new system of small/medium satellites and authorized the restructuring of its LMI joint venture as the organization defines its long-term strategy to serve international telecommunications markets. The project was initiated to enable the organization to take full advantage of the improvements in spacecraft design, while meeting the current and future requirements of the telecommunication market.

“The new project – designated Intersputnik-100M – provides great possibilities for private investors with limited funds and for countries with average demand for the telecommunications traffic, which are willing to establish communications networks using their own satellites”, Intersputnik’s Director General Gennady Kudryavtsev said.

In taking its decision, the Intersputnik board acknowledged that the current use of modern heavy satellites with many transponders is not always economically viable or efficient for regional and national communications networks with medium and small capacities. In these cases, a network of smaller capacity, lighter satellites would be very efficient.

Intersputnik possesses extensive orbital resources, which consist of 5 geostationary orbital slots (from 97° West to 153.5° East), where the organization has filed 51 satellite networks (15 C- and Ku-band and 36 S-, Ka- and V-band) with the International Telecommunication Union. These slots will serve as a basis for the deployment of the prospective satellite communications system.’

CST Note:

Apparently the information on this project was given to the main Russian candidates for the Intersputnik tender much earlier than November 2000 since designs or mock-ups of prototypes of all three projects discussed below were exhibited by 1999.

Express-AK

The 'Express-AK' satellite is on the basis of the 'Express-1000' space bus which was developed on a contract with the 'Rosaviacosmos', but further financing from the budget of the Agency is not foreseen in the Federal Space Plan (FKP-2005) covering the period to 2005. The spacecraft is shown in Figure 9 and packed for a 'cluster launch' (the most likely method) in Figure 2.

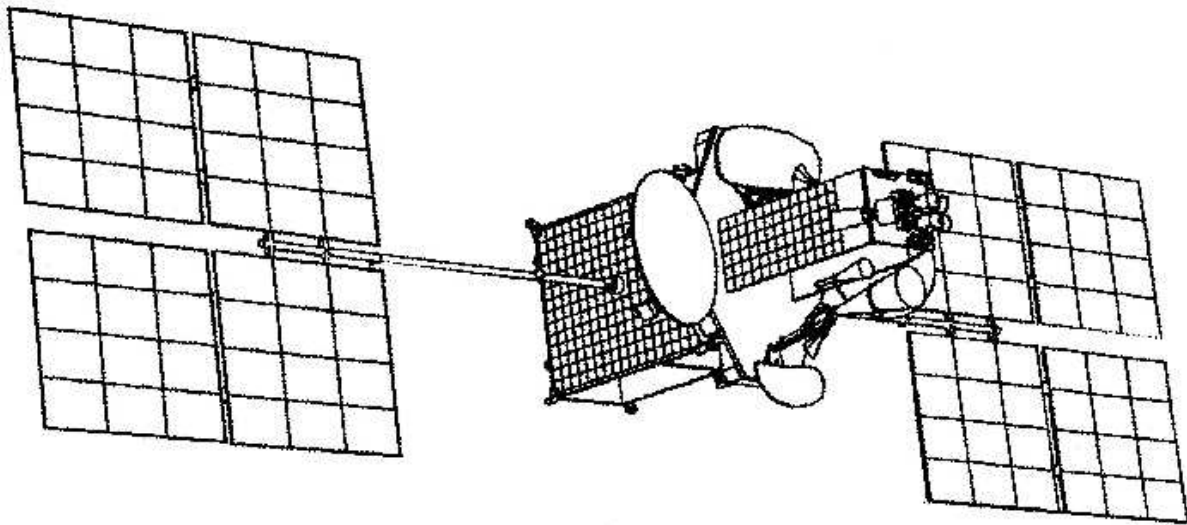

Fig. 9. The 'Express-AK' satellite. (NPO PM)

The 'Express-1000' bus is an unusual development of NPO PM. (NPO PM, Prikladnoy Mehaniki was, before 1991 the monopoly supplier of communication satellites to the Soviet Union. It is now racing to improve its technology to address both growing internal competition and the world market.) Its project was developed on a contract with 'Rosaviacosmos' which had foreseen only the development of design documentation. The following realization of this project should be carried out with non-budget financing (see above). The mass of this bus should be 600 kg while the total mass of the 'Express-AK' satellite on its base should be no more than 840 kg. Such geostationary communication satellites having 10-12 transponders of C- and Ku-bands (depending on options) would be cheaper not only in their own cost price but also thanks to the opportunity to be launched by cheaper launch vehicles (for example, by the 'Rus' launcher instead of the 'Proton') or in clusters. While the project of 'Express-K' is being supported, by an inclusion into FKP-2005, as an attempt to achieve the current general level of Western satellites, the 'Express-1000' promises to be an advanced development in the field of small geostationary satellites. The lack of budget financing for the deployment of a satellite communication

system on its base is explained, apparently, besides a general lack of money in the budget of 'Rosaviacosmos', by a hope to win a tender announced by Vietnam for a communication satellite of similar type. The winning of this tender would allow not only the establishment of production and to test the satellite at the expense of a customer but also to gain money for the construction of other satellites for Russian needs.

Dialog

Khruichev is developing a number of variants of its Dialog project (not just as a response to the Intersputnik ITT). An impression of the appearance of Dialog-E is shown in Figure 10. If the Rokot+ion propulsion method of insertion of this satellite cannot be readied before the satellites, then Khruichev will cluster launch them with Proton if contractually obliged to do so. This option is not available for NPO-M for Ruslan-MM (see below) since it does not own the rights to any other launcher than Strela and would have to purchase the launches in a 'hard' market, against pressure from competitors.



Fig. 10. Artistic picture of the ‘Dialog-E’ satellite published in April 2001. (Khrunichev)

The characteristics of Dialog-E, which of course are subject to change are as follows:

| | |
|--|----------------------|
| • Orbital slot | 53.0° East Longitude |
| • Accuracy of orbital position maintaining, <i>deg.</i> : | |
| by inclination | 0.1 |
| by longitude | 0.1 |
| • Mass of spacecraft in operation orbit in beginning of operation, <i>kg</i> | 495 |
| • Mass of satellite’s payload, <i>kg</i> | 59 |
| • No. of C and Ku band transponders (can increase 2x for non ion insertion) | 2 each |
| • Lifetime of satellite without taking into consideration the resource of propulsion system, <i>years</i> | up to 10 |
| • Resource of propulsion system, <i>years</i> | 5...7 |
| • Maximum error of satellite’s coordinate axes attitude determination, <i>angl. min</i> | 6 |
| • Power of solar arrays in beginning of operation, W | 3900 |
| • Total impulse of propulsion unit, <i>ton-s</i> | 300 |
| • Electric power consumption in operation | 690 W max |
| • Dimensions, <i>mm</i> : | |
| height | 2650 |
| width in plane of solar arrays with folded solar arrays | 2075 |
| with unfolded solar arrays | 15790 |
| width in plane of PEM’s main antennas (in unfolded position) | 2135 |
| • Time of transition from parking orbit to GEO, <i>days</i> | 210 |
| • Launch vehicle | ‘Rockot’ |

Ruslan-MM

The first project for the ‘Ruslan-MM’ small communication satellite (‘MM’ means ‘Modified Small’ in Russian) was ready in early 1999 (a mock-up of this satellite was shown at the MAKS-99 Airshow in 1999). The main feature of this satellite was a capability to be injected by the ‘Strela’ small launcher into a parking orbit with a following transfer into GEO by its own on-board electric reaction propulsion unit (ERPU) (the same concept was laid down by Khrunichev into its ‘Yacht’ space bus project for geostationary/interplanetary spacecraft almost simultaneously). According to the project at that time, the ‘Ruslan-MM’ should have a mass in parking orbit of 620 kg and in GEO of 520 kg with the mass of payload 125 kg.

Around the middle of 2001 a contract was signed for two Intersputnik-100M satellites and an improved Ruslan-MM was exhibited as a mock-up at the Moscow MAKS-2001 airshow in August 2001, Figure 11. The basic characteristics of the satellite given at that time are listed below.

| | |
|---|-------|
| • Mass in orbit, kg | 560 |
| • Mass of payload, kg | 125 |
| • Power consumption by payload, W | 1000 |
| • Accuracy of station keeping by latitude/longitude, <i>deg.</i> | ±0.1 |
| • Time of injection into GEO, <i>days</i> | 150 |
| • Life time, <i>years</i> | 10-12 |



Fig. 11. Mock-up of the improved 'Ruslan-MM' shown at the MAKS-2001 Airshow in 2001. (CST photo)

No information is yet to hand on the 2001 payload, but three options for the 1999 version listed either 12 C-band, 6 Ku-band or 6C+3Ku band transponders with respective total power consumptions 800, 750 or 820 Watts. The transmitted power output of C-band TWTs was 15 Watts and for Ku band 40 Watts.

The likely difficulties with launching options for Ruslan-MM have been given above, but the necessities of contract obligations, when and where they exist, will drive NPO-M to find a way.

6. Conclusion

An exciting new field for mini-satellites in GEO is opening up and some explorers are 'boldly going'. Exactly what will happen is still unclear but the method and cost of access is the key, as for all other fields of space use.

Some well founded projects, GEMINI, Express-AK, Dialog and Ruslan-MM lead the way and all are exploring innovative launching options with costs commensurate with satellite costs. The transponder quantity, type and power as a function of the mass

and lifetime of the satellites will also be very important in deciding the winning designs.

Regulatory factors and politics will of course play a role, apart from the engineering, in deciding whether a mini-satellite in GEO is worthwhile. Many new players could join and enrich the field of GEO communication satellites and it remains to be seen if their blossoming will be blighted by unfair play from the established giants.

References

1. "Launching Small Satellites in the Former Soviet Union." 17th Annual AIAA/USU Conference on Small Satellites, August 11-14, 2003.
2. Guide to launching small satellites – 7th edition, – published privately by CST for customers.
3. Satnews, January 3, 2001.