

July 2016

The Influence of Discrete Emotional States on Preferential Choice

Andrea M. Cataldo
University of Massachusetts Amherst

Follow this and additional works at: https://scholarworks.umass.edu/masters_theses_2



Part of the [Cognition and Perception Commons](#), [Cognitive Psychology Commons](#), [Experimental Analysis of Behavior Commons](#), [Personality and Social Contexts Commons](#), and the [Quantitative Psychology Commons](#)

Recommended Citation

Cataldo, Andrea M., "The Influence of Discrete Emotional States on Preferential Choice" (2016). *Masters Theses*. 339.

https://scholarworks.umass.edu/masters_theses_2/339

This Open Access Thesis is brought to you for free and open access by the Dissertations and Theses at ScholarWorks@UMass Amherst. It has been accepted for inclusion in Masters Theses by an authorized administrator of ScholarWorks@UMass Amherst. For more information, please contact scholarworks@library.umass.edu.

THE INFLUENCE OF DISCRETE EMOTIONAL STATES ON PREFERENTIAL CHOICE

A Master's Thesis

by

ANDREA M. CATALDO

Submitted to the Graduate School of the
University of Massachusetts Amherst in partial fulfillment
of the requirements for the degree of

MASTER OF SCIENCE

May 2016

Psychology

© Copyright by Andrea M. Cataldo 2016

All Rights Reserved

THE INFLUENCE OF DISCRETE EMOTIONAL STATES ON PREFERENTIAL CHOICE

A Master's Thesis

by

ANDREA M. CATALDO

Approved as to style and content by:

Andrew Cohen, Chair

Linda Isbell, Member

Jeff Starns, Member

Hal Grotevant, Department Head
Psychological and Brain Sciences

ABSTRACT

THE INFLUENCE OF DISCRETE EMOTIONAL STATES ON PREFERENTIAL CHOICE

MAY 2016

ANDREA M. CATALDO, B.A., UNIVERSITY OF MASSACHUSETTS AMHERST

M.S., UNIVERSITY OF MASSACHUSETTS

Directed by: Andrew Cohen

Past research has shown that emotion affects preferential choice outcomes. The goal of the present study was to further research on emotion and preferential choice by using mathematical modeling to investigate the effects of specific dimensions of emotion on the underlying mechanisms of preferential choice. Specifically, we aimed to determine whether the concurrent effects of positive-negative valence and situational certainty on attention and information accumulation threshold, respectively, would influence the magnitude of the similarity effect, a robust phenomenon in preferential choice. Participants first underwent either an Anger (negative and certain), Fear (negative and uncertain), or no (Control) emotion manipulation. All participants then completed an apartment choice task that was designed to elicit the similarity effect. A novel framing manipulation was used to test the effects of emotional valence on attention. Both feature framing and emotion condition significantly affected choice outcomes. These results suggest differences in deliberation style between Anger and Fear participants, as well as a surprising impact of alternatives outside the choice set on choice outcomes. Future directions are discussed.

TABLE OF CONTENTS

	Page
ABSTRACT	iv
LIST OF TABLES.....	vii
LIST OF FIGURES.....	viii
CHAPTER	
1. EMOTION AND PREFERENTIAL CHOICE.....	1
1.1 Introduction	1
1.2 Models of Preferential Choice.....	3
1.3 The Similarity Effect	8
1.4 Emotion and Preferential Choice	13
1.5 Model Predictions.....	16
1.5.1 Multialternative Decision Field Theory	17
1.5.2 Multiattribute Linear Ballistic Accumulator	20
2. EXPERIMENT.....	23
2.1 Introduction	23
2.2 Method.....	24
2.2.1 Participants	24
2.2.2 Materials.....	24
2.2.2.1 Emotion Manipulation	24
2.2.2.2 Choice Stimuli	25
2.2.2.3 Emotion Manipulation Check.....	26
2.2.3 Procedure.....	27
2.3 Results.....	28
2.3.1 Subject and Data Removal	28
2.3.2 Emotion Manipulation Check	28
2.3.3 Preferential Choice.....	31
2.3.3.1 Behavioral Analyses	31

2.3.3.2.1 Choice Outcomes	33
2.3.3.2.2 Reaction Time	37
2.3.3.3 Mathematical Modeling	39
2.3.3.3.1 Four-Choice Simulations.....	40
2.3.3.3.2 MLBA Fitting	43
3. DISCUSSION	46
APPENDICES	
A. THE MULTIALTERNATIVE DECISION FIELD THEORY	79
B. THE MULTIATTRIBUTE LINEAR BALLISTIC ACCUMULATOR.....	85
C. VIDEO PRETESTING.....	93
D. DIFFERENTIAL EMOTIONS SCALE	106
E. CERTAINTY SCALE ITEMS.....	107
F. AROUSAL SCALE ITEMS	108
G. PREFERENTIAL CHOICE TASK INSTRUCTIONS	109
H. POST-EXPERIMENTAL QUESTIONNAIRE.....	112
I. POSITIVE AND NEGATIVE AFFECT SCHEDULE.....	114
REFERENCES.....	115

LIST OF TABLES

Table		Page
1.	Non-target Aggregate Groups in the DES	51
2.	Results of Multinomial Logistic Regression: Choice ~ Emotion:Framing:Similarity	52
3.	Results of Three-Way ANOVA: Page Submit RT ~ Emotion:Framing:Similarity	53
4.	Best-fitting Parameter Values from the Four-Choice MLBA	54
C1.	Non-target Aggregate Groups in the DES: Video Pretesting.....	100

LIST OF FIGURES

Figure		Page
1.	Multialternative Decision Field Theory.....	55
2.	Choice Stimuli Feature Ratings	56
3.	Multiattribute Linear Ballistic Accumulator.....	57
4.	Influence of Attention and Accumulation Threshold on the Similarity Effect as Predicted by the MDFT.....	58
5.	Predicted Effects of Emotion on Choice by the Three-Choice MDFT	59
6.	Predicted Effects of Emotion on RT by the Three-Choice MDFT.....	60
7.	Influence of Attention and Accumulation Threshold on the Similarity Effect as Predicted by the MLBA.....	61
8.	Predicted Effects of Emotion on Choice by the Three-Choice MLBA.....	62
9.	Predicted Effects of Emotion on RT by the Three-Choice MLBA.....	63
10.	Sample Stimuli.....	64
11.	Sample Catch Trial.....	65
12.	Average DES Ratings.....	66
13.	Average DES Positive/Negative Subscale Ratings	67
14.	Distributions of Average Responses to the Certainty Items by Condition	68
15.	Distributions of Average Responses to the Arousal Items by Condition	69
16.	Choice Proportions.....	70
17.	Differences in Choice Proportions Between S Similarity Levels	71
18.	Log-transformed Reaction Times for the Response Submission	72
19.	Predicted Effects of Emotion on Choice by the Four-Choice MDFT	73

20.	Predicted Effects of Emotion on RT by the Four-Choice MDFT	74
21.	Predicted Effects of Emotion on Choice by the Four-Choice MLBA	75
22.	Predicted Effects of Emotion on RT by the Four-Choice MLBA	76
23.	Differences in Choice Proportions Between S Similarity Levels, Based on the Best-Fitting MLBA Parameter Values.....	77
24.	Differences in RT Between S Similarity Levels, Based on the Best- Fitting MLBA Parameter Values	78
B1.	Example of Subjective Mapping of Raw Rating Values in the MLBA	92
C1.	Average DES Ratings (Video Pretesting)	101
C2.	Average PANAS Ratings (Video Pretesting)	102
C3.	Average DES Positive/Negative Subscale Ratings (Video Pretesting)	103
C4.	Distributions of Responses to the Arousal Items (Video Pretesting)....	104
C5.	Distributions of Responses to the Certainty Items (Video Pretesting)	105

CHAPTER 1

EMOTION AND PREFERENTIAL CHOICE

1.1 Introduction

Decision-making is a complex cognitive process in which a selection must be made from a set of alternatives. Preferential choice is a specific decision-making scenario that consists of choosing between multiple alternatives associated with known outcomes; for instance, choosing between apartments with known features such as size and location. It has been shown that the outcome of this process likely depends on the performance of several component processes (Roe, Busemeyer, & Townsend, 2001; Trueblood, Brown, & Heathcote, 2014). Two such mechanisms that have been noted in the literature as important predictors of preferential choice outcomes are attentional deployment and information accumulation threshold. Attentional deployment governs which features receive the greatest attention during deliberation. For example, an individual in the market for a new apartment may care more about the size of their future apartment than its location, and would therefore likely pay more attention to how small or large different available apartments are than where they are located. The information accumulation threshold governs how much information is needed before a selection is made. For example, an individual with a low information threshold would be willing to choose a new apartment after learning only a little about the available options, while another individual with a high information threshold would only be willing to make a selection after considering the available information about each apartment in

great detail. Because these component processes influence choice outcomes, it is important to investigate factors that influence their performance.

One factor that has been shown to affect preferential choice is an individual's emotional state (see Schwarz, 2000 and So et al., 2015 for reviews). Discrete emotions such as anger and fear are complex states that consist of several key dimensions, such as positive-negative valence and situational certainty (Lerner & Keltner, 2000). Recent literature has highlighted the importance of testing discrete emotional states that vary across multiple dimensions such that the differential effects of these dimensions on the component processes of decision-making might be uncovered (Tiedens & Linton, 2001). Positive-negative valence, or the degree to which an emotional state can be characterized as pleasant or unpleasant, has been shown to affect attentional deployment (Bower, 1981; Martin, Williams, & Clark, 1991; Strauss & Allen, 2006). Situational certainty, or the extent to which a particular emotion is characterized by a sense of confidence or conviction, has been shown to affect the information accumulation threshold (Bohner & Weinerth, 2001; Tiedens & Linton, 2001). However, though they occur concurrently in various emotional states, the effects of valence and certainty on preferential choice are often studied in isolation. The present study aims to further research on emotion and preferential choice by investigating the concurrent effects of valence and certainty on component processes of decision-making.

As stated, both preferential choice and emotional states represent complex processes with multiple underlying mechanisms. Mathematical modeling is an ideal method of uncovering component mechanisms in complex processes; as such,

modeling may offer a more powerful method of teasing apart the hypothesized effects. The present study will model preferential choice outcomes with two popular models to determine if differences in choice outcomes across discrete emotional states can be accounted for by changes in the component mechanisms represented in the model: Multialternative Decision Field Theory (MDFT; Roe et al., 2001) and the Multiattribute Linear Ballistic Accumulator (Trueblood et al., 2014). Specifically, we will model the influence of discrete emotional states on the similarity effect (Tversky, 1972), a robust phenomenon in preferential choice. The similarity effect is ideal for investigating the component processes of decision-making because it is a robust phenomenon with consistent predictions about choice outcomes. Furthermore, both the MDFT and the MLBA make specific predictions regarding the effects of attentional deployment and information threshold on the similarity effect. We will therefore test the effects of emotion on preferential choice using a paradigm designed to elicit the similarity effect.

1.2 Models of Preferential Choice

The present study makes predictions about how emotional valence and certainty will influence preferential choice outcomes using two popular models: the Multialternative Decision Field Theory (MDFT; Roe et al., 2001) and the Multiattribute Linear Ballistic Accumulator (MLBA; Trueblood et al., 2014). The MDFT and the MLBA have some core characteristics in common. Both models predict the outcome in preferential choice scenarios consisting of multiple alternatives that are each described along multiple attributes, or features. Both

models are also accumulation models, meaning that information accumulates for each alternative over time. This information contributes either positively or negatively to that alternative's overall perceived value, or preference strength. The first alternative whose preference strength reaches a preset threshold value is chosen; therefore, a higher threshold requires a stronger preference state in order to be surpassed. Beyond these commonalities, the two models differ in the specific process by which information about each alternative is gathered and integrated.

According to the MDFT (Figure 1), the first stage of preferential choice involves deploying attention to a particular feature. This is accomplished via a feed-forward process in which an initial matrix M , consisting of the ratings of each alternative across each feature, is multiplied by the attention vector W , which probabilistically activates one feature at a time based on predetermined attention weights for each feature. If the weight for one feature is larger than the weight for the other feature, then the former feature will have a greater probability of becoming active and, therefore, have a greater probability of being considered at any particular moment. The activated ratings are then compared across alternatives to create a momentary impression, or valence V of each alternative relative to the others. Specifically, each valence is the product of the activated ratings and a contrast matrix comparing the rating of the alternative i to the average rating of all other alternatives for the activated feature. Finally, the preference strength P of each alternative is updated through integration with its corresponding valence as well as a feedback matrix S . The feedback matrix represents a competitive process in which alternatives inhibit each other as a function of their similarity: the greater the

similarity of two alternatives' ratings in the activated feature, the more the dominant alternative will inhibit the weaker alternative. The entire process described above repeats itself until the preference strength of one of the alternatives exceeds the individual's predetermined threshold. The full details of the model can be found in Appendix A.

To illustrate, consider the scenario of choosing between two new apartments, X and Y. Apartment X rates well in location and poorly in size, while apartment Y rates poorly in location and well in size (see points X and Y in Figure 2). By chance, it happens that attention is given to the location feature during first consideration, meaning that only the location ratings are considered. The location ratings for apartment X and apartment Y are compared, and the first impression is that apartment X is the better choice. The apartments X and Y are not particularly similar to one another in location and therefore do not "compete" heavily with each other; rather, X is the clear winner and the currently preferred choice. On a second consideration, however, it may be that attention is given to the size feature, meaning that only the size ratings are considered. The size ratings for apartment X and apartment Y are compared, and the second impression is that apartment Y is the better choice. The apartments X and Y are again not particularly similar to each other in size, and Y is the clear winner without additional scrutiny. The two apartments are now equally preferred. Each apartment continues to be compared along one feature at a time until one apartment's preference strength exceeds the individual's personal threshold. If the individual cares more about location, they will be more likely to compare apartments along the location and will therefore likely

choose apartment X. If they care more about size, then the apartments will likely be compared along the size feature more often and apartment Y will be the more likely choice.

In the MLBA (Figure 3), the initial preference strengths for each alternative are randomly sampled from a uniform distribution between zero and an upper limit A . Unlike the MDFT, in which the preference strength of each alternative can increase or decrease at each step in time, information in the MLBA is accumulated linearly such that the preference strength either only increases or only decreases at a constant rate over time. The rate at which the preference strength of each alternative increases or decreases from its starting value is determined by each alternative's drift rate, which is randomly sampled from a normal distribution with a mean of d and a standard deviation of s . The parameter d is calculated by a valuation function in which the difference between the ratings of a given alternative and the ratings of each other alternative along each feature is multiplied by two sets of attention weights: feature weights and weights for positive vs. negative comparisons. Feature weights refer to the amount of attention given to each feature. If these weights are equal for each feature, then the comparisons between alternatives along both features will have an equal impact in the valuation function. If the attention weight for one feature is larger than the attention weight for another feature, then comparisons between alternatives in the former feature will have a greater impact than comparisons in the latter feature. Weights for positive vs. negative comparisons have similar effects: if positive and negative comparisons are weighted equally, then the "loss" that an alternative receives when compared to a

dominant alternative will be equal in absolute terms to the “gain” that the dominant alternative receives. The value of d for each alternative is the sum of that alternative’s weighted differences along each feature, as well as a positive constant that ensures that the drift rate will be positive (and therefore approaching the decision threshold) for at least one alternative. Once the preference strength of at least one alternative exceeds the threshold value, that alternative is chosen. The full details of the model can be found in Appendix B.

To illustrate, consider again the two apartments X and Y. By chance, the individual may start out with a small preference for apartment X. When compared, each apartment has one “gain” and one “loss”: apartment X is better than apartment Y in location, but apartment Y is better than apartment X in size. Perhaps the individual cares more about size than location. In that case, the gain that apartment Y received for being better rated in size will matter more than the gain that apartment X received for being better rated in location; similarly, the loss that apartment X received for being poorly rated in size will matter more than the loss that apartment Y received for being poorly rated in location. The impression of apartment Y is better than the impression of apartment X. Perhaps the individual also cares more about losses than gains. In that case, the overall value of each apartment would depend more on losses than gains. The gain that apartment Y received will no longer outweigh the gain that apartment X received as much as it initially did, but the loss that apartment X received will now be much larger proportionally than the loss that apartment Y received. The impression of apartment Y is still better than the impression of apartment X, but more likely due

to the loss that apartment X received. The longer each apartment is considered, the stronger these impressions get. Thus, though apartment X started out as the preferred option by random chance, the more the two apartments are considered the more likely apartment Y will surpass apartment X. If the individual's threshold is low, it is possible that they will choose apartment X impulsively. Otherwise, apartment Y is likely to be chosen.

1.3 The Similarity Effect

The present paper focuses on a particular scenario in preferential choice known as the similarity effect (Tversky, 1972). The similarity effect is ideal for investigating the component processes of decision-making because it is a robust phenomenon with consistent predictions about choice outcomes. Furthermore, both the MDFT and the MLBA make specific predictions regarding the effects of attentional deployment and information threshold on the similarity effect. To illustrate the similarity effect, consider again the scenario of choosing between apartments. Recall that apartment X rates well in its location but it rates poorly in size. In contrast, apartment Y rates poorly in its location, but rates well in size (see points X and Y in Figure 2). If an individual places more weight on location than size, apartment X will be likely to be chosen, and if an individual places more weight on size than location, apartment Y will be likely to be chosen. If we assume that the two features are weighted approximately equal the probabilities of choosing either apartment will also be approximately equal.

Suppose then that apartment S_x becomes available. This apartment is similar to apartment X and dissimilar to apartment Y. Specifically, apartment S_x rates slightly better than apartment X in its location, but slightly worse than X in size (see points X, Y, and S_x in Figure 2). Now, an individual who gave greater consideration to size would still choose apartment Y, but an individual who gave greater consideration to location would choose apartment S_x . That is, the introduction of apartment S_x to the choice scenario means that the probabilities of choosing either apartment X or apartment Y are no longer approximately equal; apartment S_x lowers the probability of choosing apartment X by virtue of rating similarly well in its location, but does not lower the probability of choosing apartment Y as it rates much worse in size and is therefore not competitive with Y in this feature. Thus, apartment Y is now more likely to be selected than apartment X. This phenomenon violates a principle of preferential choice known as *independence from irrelevant alternatives* (Tversky, 1972), which states that the probability of choosing a given alternative (e.g., X) in a choice set (e.g., X, Y, & S_x) cannot be larger than the probability of choosing that same alternative in a subset (e.g., X & Y).

The similarity effect is traditionally defined as a reversal in whether X or Y is the preferred option based on the choice sets described above, for instance that $p(X | X, Y) > p(Y | X, Y)$ but $p(X | X, Y, S_x) < p(Y | X, Y, S_x)$. However, previous literature has also measured the similarity effect as a comparison between two three-choice scenarios: one in which S is similar to X (S_x in Figure 2) and one in which S is similar to Y (S_y in Figure 2) (Wedell, 1991). The similarity effect is then defined as having occurred if we observe that $p(X | X, Y, S_x) < p(Y | X, Y, S_x)$ and $p(Y | X, Y, S_y) < p(X | X,$

Y, S_y). For the current purposes, the comparison between two ternary choice scenarios is to be preferred for three reasons. First, it does not require the assumption that apartments X and Y are associated with particular probabilities in a two-choice scenario (e.g., that X and Y are approximately equal, or that X is slightly preferred over Y). Second, it allows for two measures of the similarity effect because the choice probabilities for both X and Y are expected to shift. Third, the expected effect size of the change in choice probabilities ought to double when comparing two ternary choice sets rather than one binary and one ternary choice set. The increased effect size is due to the expectation that $p(X | X, Y, S_x) < p(X | X, Y) < p(X | X, Y, S_y)$ and $p(Y | X, Y, S_x) > p(Y | X, Y) > p(Y | X, Y, S_y)$. Given the benefits of the three-choice comparison over the two-choice comparison, the present study will utilize the three-choice comparison.

It is important to note that the reversal in choice preference between two choice sets represents a qualitative effect. In order to quantify the effect of S on X and Y choice probabilities, previous research (Trueblood et al., 2014) has operationally defined the similarity effect as the extent to which $p(X | X, Y, S_x) < p(X | X, Y, S_y)$ and $p(Y | X, Y, S_x) > p(Y | X, Y, S_y)$. The changes in X and Y choice probabilities are shifts that tend to occur in conjunction with the preference reversal, but ultimately are independent of it. Given the benefits of studying a quantitative shift rather than a qualitative one, going forward we will adopt this weaker definition of the similarity effect.

According to the MDFT, the similarity effect results from a combination of the comparison process that determines the valence of each option and the competition

between similar alternatives that occurs during the feedback process. When a particular feature is being considered, the preference strengths of alternatives that are similar to each other on that feature will receive similar benefits from positive comparisons when they rate well and receive similar losses from negative comparisons when they rate poorly. Alternatives that are similar to each other will therefore be correlated with one another during the comparison process.

Furthermore, similar alternatives will compete more with one another than with the dissimilar alternative during the feedback process, such that the preference strength of the dominant alternative in the attended feature will benefit and the dominated alternative will receive a loss. As a result, similar alternatives will decrease in preference strength as they compete and the preference strength of the dissimilar alternative will be allowed to rise. That is, $p(X | X, Y, S_x) < p(X | X, Y, S_x)$ and $p(Y | X, Y, S_x) > p(Y | X, Y, S_y)$.

To illustrate how the MDFT predicts the similarity effect, consider again the three apartments X, Y, and S_x . The preference strengths of apartments X and S_x will both benefit from positive contrasts when the location feature is activated because they are both rated better than the average location rating, and they will both be harmed by negative contrasts when the size feature is activated because they are both rated worse than the average size rating. Apartments X and S_x are therefore perfectly correlated with each other in gains and losses in the comparison process. In the feedback process, the high degree of similarity between apartments X and S_x will cause them to strongly compete with one another but not with apartment Y. Apartments X and S_x will alternately inhibit each other when either location is

activated (and apartment S_x dominates apartment X) or size is activated (and apartment X dominates apartment S_x). However, the dissimilar apartment Y will never be greatly inhibited regardless of which feature is activated because it only weakly competes with the other alternatives along both features. Ultimately, apartments X and S_x are equally likely to be chosen when location is the more heavily weighted feature, but apartment Y alone is likely to be chosen when size is the more heavily weighted feature. If size and location are equally weighted, apartments X and S_x are each 25% likely to be chosen while apartment Y is 50% likely to be chosen. A parallel pattern would be found in the choice set including apartments X, Y, and S_y : apartments Y and S_y would be perfectly correlated with each other in gains and losses in the comparison process and inhibit each other in the feedback process, resulting in a 25% probability of choosing either apartment Y or S_y and a 50% probability of choosing apartment X if size and location are equally weighted. That is, $p(X | X, Y, S_x) < p(X | X, Y, S_y)$ and $p(Y | X, Y, S_x) > p(Y | X, Y, S_y)$.

According to the MLBA, the similarity effect results when there is a greater attentional weight for positive differences than for negative differences in comparisons between alternatives. When two alternatives are compared along a particular feature, the drift rate of the better alternative will increase by a relatively large amount while the drift rate of the worse alternative will only moderately decrease. To illustrate, consider again the three apartments X, Y, and S_x . When comparing apartment X to apartment S_x , apartment X has a small negative difference from apartment S_x in location and small positive difference from apartment S_x in size. In the same comparison, apartment S_x has a small positive difference from

apartment X in location and a small negative difference from apartment X in size. When either apartment is compared to apartment Y, it also has one large positive difference in location and one large negative difference in size. Ultimately, apartment Y has a total of two large positive differences and two large negative differences while apartments X and S_x each have one small and one large positive difference and one small and one large negative difference. If there is a greater attentional weight for positive differences than for negative differences, then positive differences will have a greater impact than negative differences of the same size, which causes the drift rate of apartment Y to increase more than the drift rates of either apartment X or S_x . Apartment Y is therefore the most likely alternative to reach the threshold first and be chosen. A parallel pattern would be found in the choice set including apartments X, Y, and S_y : apartment X would have two large positive differences and two large negative differences while apartments Y and S_y would each have one small and one large positive difference and one small and one large negative difference. The drift rate of apartment X would consequently receive the greatest increase from the comparison process and be the most likely alternative to be chosen. That is, $p(X | X, Y, S_x) < p(X | X, Y, S_y)$ and $p(Y | X, Y, S_x) > p(Y | X, Y, S_y)$.

1.4 Emotion and Preferential Choice

Emotion has been shown to affect preferential choice (Schwarz, 2000). However, the effects of emotion on choice outcomes are often unclear or conflicting. One potential reason for this lack of clarity is that discrete emotions, such as anger

and fear, are themselves complex states that consist of several key dimensions, such as positive-negative valence and situational certainty (Lerner & Keltner, 2000).

Despite their complex nature, studies of emotion and decision-making have historically defined emotion as a one-dimensional state, commonly either in terms of physiological arousal alone (e.g., Bechara, Damasio, Damasio, & Anderson, 1994) or positive-negative valence alone (e.g., Johnson & Tversky, 1983). Recent literature has highlighted the importance of instead testing emotional states that vary across multiple dimensions, such that the differential effects of these dimensions on the component processes of decision-making might be uncovered (Tiedens & Linton, 2001).

The emotion literature identifies several dimensions that contribute to an individual's particular emotional state. The present paper focuses on two dimensions that have been noted as having a particular influence on decision-making: positive-negative valence and situational certainty. Emotional valence refers to the extent to which an emotional state is characterized as pleasant or unpleasant. Pleasant emotional states include happiness, excitement, and surprise, while unpleasant emotional states include anger, fear, sadness, and anxiety. However, emotional states within each valence category may be further distinguished along other dimensions, for example, situational certainty. Certainty refers broadly to the extent to which a particular emotion is characterized by a sense of confidence or conviction about the current environment, situation, or focus. Uncertain emotional states include anxiety, fear, and surprise, while certain emotional states include anger and happiness. When emotional states are

investigated one-dimensionally rather than in terms of discrete emotional states, such as anger and fear, dimensions such as valence and certainty risk being confounded with each other.

The present study aims to further research on emotion and preferential choice by investigating the concurrent effects of valence and certainty on decision outcomes in a preferential choice scenario. Emotion is expected to influence behavior in this paradigm via both attentional weighting and threshold, which will subsequently influence the magnitude of the similarity effect. Previous research has found that participants devote greater attention to emotion-congruent information (Bower, 1981; Martin et al., 1991; Strauss & Allen, 2006). Consequently, it is expected that when the features of the choice alternatives are framed as either positive or negative, the valence of an individual's emotional state will affect attentional deployment.

Framing will be manipulated by presenting the ratings of each of the three alternatives in the choice set along with the ratings for a fourth alternative that is currently owned by the individual and being replaced by one of the three new alternatives and can not itself be chosen. A positively framed feature will be depicted such that all choice alternatives are better than the currently owned selection on that feature, while a negatively framed feature will be depicted such that all choice alternatives are worse than the currently owned selection on that feature. It is important to note that the absolute values of the ratings for the three new apartments (i.e., the choice set) will not change between framing conditions, only the ratings of the current apartment.

Previous research has also found that participants in an emotional state characterized by a lack of situational certainty, such as fear, display more thorough information processing than participants in an emotional state characterized by a high level of situational certainty, such as anger (Bohner & Weinerth, 2001; Tiedens & Linton, 2001). Consequently, it is expected that certainty will affect information accumulation such that fearful individuals will spend more time considering each alternative (and accumulating more information) before making a choice than angry individuals.

1.5 Model Predictions

Emotion and preferential choice each have complex underlying structures. Mathematical modeling offers a powerful method of teasing apart the hypothesized effects of valence and certainty on preferential choice. To begin investigating the potential influences of valence and certainty on attentional weighting and threshold, and subsequently on the similarity effect, the paradigm was modeled using the MDFT and the MLBA. The present study investigates three main hypotheses: first, that the valence associated with a participant's emotional state affects how attention is differentially deployed to features with positive or negative framing; second, that the certainty associated with a participant's emotional state affects how systematically they consider the features of each of the alternatives in the choice set; and third, that the concurrent effects of valence and certainty influences the similarity effect. The third hypothesis is contingent upon the first two.

Since valence is predicted to affect the feature weights and certainty is expected to affect the information accumulation threshold, these parameters were each varied across three levels of magnitude in each model: low, medium, and high. Anger (negative valence, high certainty) was defined as having a low threshold with a high attentional weight for negatively framed features and a low attentional weight for positively framed features. Fear (negative valence, low certainty) was defined as having a high threshold with a high attentional weight for negatively framed features and a low attentional weight for positively framed features. The Control group (moderate valence, moderate certainty) was defined as having a medium threshold with equal attentional weights for both negatively and positively framed features. When both features were framed congruently (either both negative or both positive), attentional weights were set to be equal in all conditions.

1.5.1 Multialternative Decision Field Theory

The predicted effects of attentional weight and threshold on the similarity effect in the MDFT are summarized in Figure 4. Specific parameter values can be found in Appendix A. Figure 4 presents the probability of choosing X when it is the “similar” option ($X | X, Y, S_x$) minus the probability of choosing X when it is the “different” option ($X | X, Y, S_y$) across three levels of attention: low for location and high for size, equal for location and size, and high for location and low for size. These probabilities are estimated at high, medium, and low threshold values. Note that the similarity effect has occurred when $p(\text{“similar”}) - p(\text{“different”})$ is negative. When attention is equal for both features, the MDFT predicts that the similarity effect

decreases as threshold increases as a result of increasing inhibition accumulated in the competitive feedback process. When attention is low for location and high for size, threshold has little effect because X is poorly rated in size and therefore unlikely to be chosen at any level of threshold. When attention is high for location and low for size, threshold has a reverse effect such that the similarity effect increases as threshold increases. The probability of choosing X increases in this scenario by virtue of a greater attentional weight on its strongest feature. When X is also the “different” alternative, its increase in strength after each iteration outweighs the effects of inhibition that occur when the attention weights are equal. As a result, the similarity effect increases over time.

The predicted choice outcomes for Angry, Fearful, and Control participants by the MDFT are depicted in Figure 5. Figure 5 presents the probability of choosing each alternative in the S_x choice set minus the probability of choosing that same alternative in the S_y choice set in each of four framing conditions: negative location, positive size; positive location, positive size; negative location, negative size; and positive location, negative size. The probability of choosing X should be greater in the S_x choice set than the S_y choice set, and the probability of choosing Y should be lower in the S_x choice set than the S_y choice set. Therefore, if the similarity effect has occurred we will see negative differences in Figure 5 for X and positive differences in Figure 5 for Y. Note that the value of S changes between choice sets (from S_x to S_y) making the difference in choice probabilities for S less interpretable. However, they are still provided for context.

With our chosen parameter values, the MDFT predicts that when the features are framed congruently (both positive or both negative) the similarity effect is predicted to be largest for the Anger condition, closely followed by the Control condition, and smallest for the Fear condition. When the features are framed incongruently (positive location and negative size or negative location and positive size), participants in the Anger and Fear conditions will choose the alternative that has the highest rating in the negatively framed feature. As a result, they will exhibit a large similarity effect for X when location is framed negatively and size is framed positively and Y when size is framed negatively and location is framed positively. The magnitude of these effects will be greatest for Fear due to the predicted interaction of attention and threshold described above. They will not exhibit a similarity effect for Y when location is framed negatively and size is framed positively since Y is rated poorly in location, nor for X when size is framed negatively and location is framed positively since X is rated poorly in size. Participants in the Control condition will exhibit a standard similarity effect in the incongruent-framing conditions.

Log-transformed reaction time predictions for the MDFT are presented in Figure 6. When the two features are framed congruently, participants in the Fear condition are expected to have the longest reaction times while participants in the Anger condition have the shortest reaction times. Anger participants are still predicted to have the shortest reaction times when the two features are framed incongruently, however Fear participants no longer consistently have the longest reaction times out of all three conditions. This appears to be due to a main effect of

attention to negatively framed features. For both Anger and Fear participants, reaction time is greater for the S_x choice set in the negative location, positive size framing condition and for the S_y choice set in the positive location, negative size framing condition. This is likely an effect of whether there is an alternative that is a clear “winner” in the negatively-framed feature in a given choice set – that is, an alternative that has the best ratings in the negatively-framed feature by far. For example, X is rated best in location by far in the S_y choice set. If attention is high for location, X will be chosen quickly from that set. In the S_x choice set, however, both X and S_x are rated fairly well, and if attention is high for location then reaction time will increase as these two alternatives compete with one another. Congruently, when attention is greatest for the size feature, Y is a clear winner in the S_x choice set and will be chosen quickly, but reaction time will increase for the S_y choice set as S_y and Y compete.

1.5.2 Multiattribute Linear Ballistic Accumulator

The predicted effects of attentional weight and threshold on the similarity effect in the MLBA are summarized in Figure 7. Specific parameter values can be found in Appendix B. As with Figure 4, Figure 7 depicts the probability of choosing X when it is the “similar” option ($X | X, Y, S_x$) minus the probability of choosing X when it is the “different” option ($X | X, Y, S_y$) across three levels of attention: low for location and high for size, equal for location and size, and high for location and low for size, and these probabilities are estimated at high, medium, and low threshold values. Note again that the similarity effect has occurred when $p(\text{“similar”})-$

$p(\text{"different"})$ is negative. When attention is equal for both features the MLBA makes opposite threshold predictions to the MDFT, predicting that the magnitude of the similarity effect increases as threshold increases. While preference strengths in the MDFT can increase or decrease over time, the preference strengths in the MLBA are linear. As such, the likelihood of a weak "similar" option (e.g., $X | X, Y, S_x$) being chosen over the "different" option by chance decreases over time as the preference strengths of the alternatives grow increasingly distant from each other. However, we note that though this effect is consistent in our simulations, it is small. The MLBA makes similar predictions to the MDFT for the effects of attentional weights. When attention is low for location, X is unlikely to be chosen at any threshold; as such, the similarity effect is small. When attention is high for location, X becomes more likely to be chosen, with increasing probability over time.

The predicted choice outcomes for Angry, Fearful, and Control participants by the MLBA are depicted in Figure 8. The MLBA predicts that when the two features are framed congruently (both positive or both negative) the similarity effect is predicted to be approximately the same for the three emotion conditions. Similar to the MDFT, the MLBA predicts that when the two features are framed incongruently, participants in the Anger and Fear conditions will choose the alternative that has the highest rating in the negatively framed feature. As a result, they will exhibit a large similarity effect for X when location is framed negatively and size is framed positively and Y when size is framed negatively and location is framed positively. The magnitude of these effects will be greatest for Fear due to the predicted interaction of attention and threshold described above. Participants in the

Control condition are predicted to exhibit a standard similarity effect in the incongruent-framing conditions.

Log-transformed reaction time predictions for the MLBA are presented in Figure 9. In all conditions, participants in the Fear condition are predicted to have the longest reaction times while participants in the Anger condition are predicted to have the shortest reaction times. There is no predicted variation in the order of average reaction time across the three conditions in the MLBA as in the MDFT. Recall that in the MDFT, attention was predicted to affect reaction time in the incongruent framing conditions as a result of the presence of competition between alternatives that both rate well in the negatively-framed feature. The MLBA does not have a comparable competition mechanism, and thus does not predict that attention will affect reaction time in this manner.

CHAPTER 2

EXPERIMENT

2.1 Introduction

This study was designed to test preferential choice behavior among participants in one of two induced emotional states, Anger and Fear, as well as a third group of Control participants who did not undergo an emotion manipulation. Participants in the Anger and Fear conditions first underwent an emotion manipulation task in which they watched a video designed to induce either an angry or fearful emotional state, respectively. All participants then completed a preferential choice task in which they were asked to decide which among a set of three apartments they most preferred on each of 16 trials varied across four feature framing conditions (positive size, positive location; positive size, negative location; negative size, positive location; negative size, negative location), two average rating values (one relatively low, one relatively high), and similarity of apartment S (to either apartment X or apartment Y). Two catch trials were also included to test participants' engagement in the task. All participants then completed the Differential Emotions Scale (Boyle, 1984), items measuring arousal and certainty, and a demographics questionnaire. Participants in the Anger and Fear conditions finished by watching a video intended to reinstate a happy emotional state.

2.2 Method

2.2.1 Participants

A total of 744 participants were recruited to complete the study on Amazon's Mechanical Turk (MTurk; Buhrmester, Kwang, & Gosling, 2011). One hundred thirty-five participants were excluded from either the Anger or Fear conditions for not watching the full video and a total of 12 participants from all three conditions were excluded for having technical difficulties with the study, leaving 597 participants in the analyses (193 Anger, 185 Fear, 219 Control). Participants in the Control condition earned \$0.10 while the Anger and Fear conditions earned \$0.20 (due to the additional emotion manipulation and reinstatement).

2.2.2 Materials

2.2.2.1 Emotion Manipulation

Prior to implementing the main experiment, several videos were pretested for their suitability as stimuli in an emotion manipulation task. Specifically, each video was tested for its reliability in inducing a target emotional state of either Anger or Fear as well as inducing the associated target component states: negative valence and low/high certainty. Viewing video clips has been shown to reliably produce relevant emotions in participants (Gross & Levenson, 1995; Schaefer, Nils, Sanchez, & Philippot, 2010). The specific methodological details of the video pretesting are included in Appendix C. Across measures of emotional state, positive and negative valence, arousal, and certainty, a scene from *Schindler's List* (a; 1:55) in which a concentration camp officer is shown shooting prisoners performed best

among the Anger videos while a scene from *Blair Witch Project* (3:57) in which the characters arrive at an ominous cabin in the woods performed best among the Fear videos. These videos were therefore chosen as stimuli for the Anger and Fear conditions in the emotion manipulation task in the main experiment. Given the lack of consensus regarding what defines a neutral emotional state, or in fact whether a neutral emotional state is possible, no video manipulation was used for the Control participants.

2.2.2.2 Choice Stimuli

During testing, participants were presented with 18 trials each consisting of a choice scenario for which all alternatives and all features were presented simultaneously. The choice sets consisted of three different apartments that have been rated according to two features: size and location. The feature ratings were depicted as filled bars, with the proportion of the fill representative of the size of the rating of that feature on a scale from “Worst for Me” (unfilled) to “Best for Me” (completely filled). On each trial the ratings for apartment S varied such that they were similar to either apartment X (S_x) or apartment Y (S_y). Importantly, though each apartment varied in terms of whether it rated better on size or location, the three alternatives within a set always shared the same expected value when the ratings for the two features were averaged. That is, there was never a best option in a given trial. The expected value of the apartments in a choice set was varied for generalizability such that all apartments had an average rating of either 1.5 or 2.5 within a trial. The specific ratings for the three apartments in the EV=2.5 condition

are outlined in Figure 2; the ratings for the apartments in the EV=1.5 condition are the same as the EV=2.5 condition minus one.

The ratings of a fictional current apartment being replaced by one of the new alternatives were also presented (see Figure 10). These ratings set the positive and negative framing of each feature. As previously described, a positively framed feature was depicted such that all choice options were better than the current option in that feature while a negatively framed feature was depicted such that all choice options were worse than the current option in that feature. There were four levels of feature framing: positive size and negative location (Figure 10, top left panel), positive size and positive location (Figure 10, top right panel), negative size and negative location (Figure 10, bottom left panel), and negative size and positive location (Figure 10, bottom right panel).

The factors described above resulted in 16 testing trials: two expected values by two similarity conditions by four feature frames. In addition, each participant was shown two catch trials in which one apartment had a larger expected value overall than the other two; that is, there was an alternative that was a clear best (Figure 11). These trials were included to identify participants who were not sufficiently engaged in the task.

2.2.2.3 Emotion Manipulation Check

After testing, participants completed the Differential Emotions Scale (DES; Boyle, 1984) as a measure of discrete emotional state and positive-negative valence. In the interest of time participants completed only a subset of items from the

original DES (see Appendix D). Seven-point Likert scale items were used to measure situational certainty (see Appendix E) and physiological arousal (see Appendix F).

2.2.3 Procedure

Each participant in the Anger and Fear conditions was recruited under the impression that they would participate in two unrelated studies: one on decision-making and another in which they would rate the emotionality of different video clips. The video task was completed first and served as an emotion manipulation for the subsequent preferential choice task. As previously stated, Control participants did not complete an emotion manipulation and instead began with the preferential choice task.

Participants were given detailed instructions for the preferential choice task and completed three practice trials before testing (see Appendix G). Each response involved first clicking the button on the screen associated with the desired alternative and then clicking another button to submit the response. It was therefore possible for participants to change the selected alternative before submitting a final response.

Once participants completed the preferential choice task they were asked to complete the emotion measures specified above, as well as a brief demographics questionnaire (see Appendix H). Participants in the Anger and Fear conditions had an additional positive emotion reinstatement task in which they viewed a physical comedy scene from *Benny and Joon* (2:06).

2.3 Results

2.3.1 Subject and Data Removal

Two catch trials were included in the choice task to check whether participants were sufficiently engaged in the task. These trials included a clear best alternative that had a higher expected value than the other two (see Figure 11). A total of 70 participants who did not choose the correct alternative on either catch trial were excluded from the study, leaving 527 participants in the analyses (171 Anger, 171 Fear, 185 Control).

Recall that the choice sets were varied for generalizability such that all alternatives within a set had an expected value of either 1.5 or 2.5. One stimulus in the EV=1.5 condition contained a design error that made this condition an incomplete design. Therefore only the EV=2.5 condition is included in the following analyses.

2.3.2 Emotion Manipulation Check

The participants' responses to the DES are displayed in Figure 12. The emotions listed in the DES were collapsed into the same aggregate groups using the same methodology as described in the pretesting experiment: angry $\alpha=0.946$; fear $\alpha=0.982$; calm $\alpha=0.956$. The non-target aggregate groups are detailed in Table 1.

The goal of the DES in the main experiment was to verify both that the target emotion was stronger than the other emotions (e.g., reported anger was the strongest emotion in the Anger condition) and that the target emotion in a given condition was stronger than in the other two conditions (e.g., reported anger was stronger in the Anger

condition than in the Fear or Control conditions). An ANOVA was performed with emotion condition as a between-subject variable and the reported emotion group as a within-subject variable. There was a main effect of emotion condition, $F(2, 524)=80.72$, $p<0.001$ and a main effect of reported emotion group, $F(2, 1048)=12.5$, $p<0.001$. Importantly, a strong interaction effect of reported emotion group and condition was also found, $F(4, 1048)=208.4$, $p<0.001$.

Planned contrasts indicated that emotions in the anger group were rated highest by participants in the Anger condition, $t(268.11)=17.78$, $p<0.001$; emotions in the fear group were rated highest by participants in the Fear condition, $t(337.60)=9.07$, $p<0.001$; and emotions in the calm group were rated highest by participants in the Control condition, $t(322.96)=16.06$, $p<0.001$. Further, emotions in the anger group were rated higher than emotions in the fear or calm groups among participants in the Anger condition, $t(349.34)=10.20$, $p<0.001$; emotions in the fear group were rated higher than emotions in the anger or calmness groups among participants in the Fear condition, $t(280.53)=12.48$, $p<0.001$; and emotions in the calm group were rated higher than emotions in the anger or fear groups among participants in the Control condition, $t(257.36)=21.10$, $p<0.001$. The emotions were appropriate to the conditions.

Ratings of positive and negative valence were measured using the same subscales of the DES computed in the video pretesting experiment with the exception of the word items that were removed in the present experiment (see Appendix C). The average ratings for each subscale in each condition are presented in Figure 13. An ANOVA was performed with emotion condition as a between-subject variable and valence subscale as a within-subject variable. There was a main effect of emotion condition, $F(2, 524)=44.26$,

$p < 0.001$ and a main effect of valence subscale, $F(2, 524) = 300.9, p < 0.001$. An interaction effect of valence subscale and condition was also found, $F(2, 524) = 410.0, p < 0.001$.

Planned contrasts indicated that the Anger and Fear conditions each rated the negative subscale significantly higher than the positive subscale ($t_{Anger}(266.11) = -27.29, p < 0.001$, $t_{Fear}(263.85) = -16.72, p < 0.001$), while the Control condition rated the negative subscale significantly lower than the positive subscale, $t(293.82) = 9.77, p < 0.001$. The Anger and Fear conditions were therefore characterized by a negative emotional valence while the Control condition was not.

Certainty was measured by averaging across the four Likert scale items for each participant. The distributions of the average certainty scores are presented in Figure 14. A one-way between-subject ANOVA was performed with emotion condition as the independent variable. There was a main effect of emotion condition, $F(2, 524) = 37.27, p < 0.001$. A planned contrast indicated that the Anger condition reported significantly higher certainty than the Fear condition, $t(338) = -7.12, p < 0.001$.

Arousal was measured by averaging across the two Likert scale items for each participant. The distributions of the average arousal scores are presented in Figure 15. A one-way between-subject ANOVA was performed with emotion condition as the independent variable. There was a main effect of emotion condition, $F(2, 524) = 62.62, p < 0.001$. Planned contrasts indicated that both the Anger and Fear conditions reported significantly higher levels of arousal than the Control condition, $t_{Anger}(342.96) = -11.29, p < 0.001$ and $t_{Fear}(330.93) = -7.72, p < 0.001$.

2.3.3 Preferential Choice

2.3.3.1 Behavioral Analyses

There are three main hypotheses for the present study. The first hypothesis states that participants in a negative emotional state (Anger and Fear) would attend more to negatively framed features than participants who were not in a negative emotional state (Control). Participants in the Anger and Fear conditions were therefore expected to be more likely to choose alternatives that were rated best in the negatively framed feature on trials in which the two features were framed incongruently (see Figure 2 for rating values). Specifically, when location was framed negatively and size was framed positively, participants in the Anger and Fear conditions, but not the Control condition, are expected to prefer (S | X, Y, S_x) and (X | X, Y, S_y). When location was framed positively and size was framed negatively, participants in the Anger and Fear conditions are expected to prefer (Y | X, Y, S_x) and (S | X, Y, S_y). The first hypothesis will be tested with a multinomial logistic regression. The first hypothesis will be supported if there is an interaction of framing and emotion in the regression.

The second hypothesis states that the certainty associated with a participant's emotional state would affect the amount of time that a participant spends considering a given choice set, and consequently how systematically the features of each of the alternatives in the set are considered. Therefore, participants in an emotional state characterized by uncertainty, such as fear, were expected to consider the features of each of the alternatives in a more systematic fashion than participants in an emotional state characterized by certainty, such as anger. The

second hypothesis will be tested with a three-way mixed ANOVA. The second hypothesis will be supported if there is a main effect of emotion in the ANOVA. Recall that both the MDFT and the MLBA predicted that differences in deliberation style would affect choice outcomes as well as reaction times. Therefore, the second hypothesis will also be supported by a main effect of emotion condition in the logistic regression, such that particular emotions are systematically more or less likely to choose the preferred alternative (i.e., the most likely alternative in a given choice set) as predicted by the models.

The third hypothesis states that differences in attentional deployment and deliberation across conditions would in turn affect the magnitude of the similarity effect. When the features were congruently framed such that they were either both positive or both negative, the standard similarity effect was expected for participants in all conditions, which would be supported by a main effect of similarity in the regression. For the Anger and Fear conditions, however, we would expect a different pattern of results for the incongruent framing conditions. Specifically, we would expect that $(X | X, Y, S_x) < (X | X, Y, S_y)$ but not that $(Y | X, Y, S_x) > (Y | X, Y, S_y)$ when location was framed negatively and size was framed positively, and $(Y | X, Y, S_x) > (Y | X, Y, S_y)$ but not that $(X | X, Y, S_x) < (X | X, Y, S_y)$ when size was framed negatively and location was framed positively. The third hypothesis would be supported by a three-way interaction of framing, emotion, and similarity in the regression. However, we remind the reader that due to the complex nature of the predicted effects, the mathematical modeling presented in the following section will

serve as the primary test of this hypothesis rather than the three-way regression interaction.

2.3.3.2.1 Choice Outcomes

The raw choice outcomes are displayed in Figure 16. The top panel represents trials in which S is similar to X and the bottom panel represents trials in which S is similar to Y. Differences in choice outcomes were tested with a multinomial logistic regression with emotion condition (Anger, Fear, and Control), framing condition (positive location, positive size; negative location, positive size; positive location, negative size; and negative location, negative size), and similarity of S (S_x and S_y) as factors. A multinomial logistic regression is used to estimate the response probabilities for a dependent variable for which there are multiple nominal outcomes, as predicted by one or more factors. The coefficients of the model refer to the changes in the probabilities associated with deviations from a baseline. For the present test the baseline was set as the probability of choosing S when a participant was in the Control condition, location and size were both framed positively, and S was similar to X. The baseline condition is represented by the Control participants in the upper right-hand quadrant of the top panel of Figure 16. The probability of choosing S was set as the baseline outcome because only changes in the probabilities of X and Y are relevant to our hypotheses. The Control condition and positive feature frames were chosen as baseline factor levels because they most closely approximated the conditions of past research. The choice to use the S_x similarity level rather than S_y in the baseline model was arbitrary. The intercepts

represent the change in the probability of choosing X over S_x or Y over S_x for the same baseline model. All other coefficients refer to the changes in the probabilities of choosing X or Y over S_x (or S_y , depending on the similarity level) as each level of each factor changes. For example, the coefficient for the negative location, positive size framing condition (“-L, +S”) under an X outcome would refer to the change in the probability of choosing X over S_x in that framing condition compared to when both features are framed positively. The full set of β estimates, odds ratios, and standard errors for each deviation from this baseline are detailed in Table 2. Given the large number of coefficients, only effects that are relevant to the study’s hypotheses and are significant will be discussed.

There is a small but consistent effect of emotion condition throughout Figure 16 in which participants in the Anger condition choose the preferred alternative (i.e., the alternative with the highest choice proportion) in a given trial even more often than participants in the other two conditions. This effect is statistically significant (see “Anger” in Table 2). Though there is not a similar trend for Fear, this does constitute weak evidence for the second hypothesis that differences in deliberation between emotion conditions will result in consistent differences in choice outcomes between the emotion conditions. This particular trend most closely resembles the threshold predictions of the MDFT, which stated that the lower threshold values hypothesized for Anger participants would result higher choice proportions for the preferred option in a given choice set.

Comparing the four quadrants of each panel in Figure 16, it is apparent that there is a striking main effect of framing condition on choice proportions. When the

two features are framed incongruently, as in the upper left-hand and lower right-hand quadrants of each panel, there is an overwhelming preference for a particular alternative. Specifically, the alternative that has the best rating in the negatively framed feature is consistently the most preferred choice in these cases. For example, Y is chosen most often in the lower right-hand quadrant of the top panel of Figure 16 because Y has the highest size rating in the S_x choice set and size is framed negatively in that quadrant. Each of the incongruent framing conditions has a significant effect on choice proportions (see “-L, +S” and “+L, -S” in Table 2). The first hypothesis predicted that this effect would be more extreme for the Anger and Fear conditions than the Control conditions. Though we see a trend in this direction for Anger (see the upper left-hand and lower right-hand quadrants of Figure 16), there are no significant interactions of these framing conditions and any of the emotion conditions (see “Anger: -L, +S”, “Anger: +L, -S”, “Fear: -L, +S”, and “Fear: +L, -S” in Table 2).

The final framing condition, in which both features are framed negatively, is depicted in the lower left-hand quadrants of each panel of Figure 16. There is a surprising effect of this framing condition in which rather than preferring the dissimilar alternative, as we would expect, participants are now most likely to choose the “similar” alternative. That is, participants prefer the alternative out of X and Y that is most similar to S. This is a very intriguing finding that violates the premises of the similarity effect, and to our knowledge this is the first time it has been observed in the literature.

To speculate about why this effect might have occurred, refer to the lower left-hand panel of Figure 10. In this framing condition all three alternatives rate worse than the current apartment in both size and location. It may therefore help to characterize the similar alternative (apartment 1 in Figure 10) as the “middling” option that never has the best or worst rating in either size (such as apartment 3) or location (such as apartment 2). As a result, this alternative also never has the greatest *loss* in either feature when compared to the participant’s hypothetical current apartment. It is possible then that participants prefer the similar alternative because they would rather take a moderate loss in both size and location than the largest possible loss in either feature. Though this trend is consistent for all emotion conditions, it is only significant for the Anger condition (see “Anger: -L, -S” in Table 2).

It is easier to discuss the extent of the similarity effect in the data and its potential interactions with emotion and framing by referring to Figure 17, which summarizes the data in terms of the difference in choice proportions between the X, Y, S_x choice set and the X, Y, S_y choice set. Given that $(X | X, Y, S_x) < (X | X, Y, S_y)$ and $(Y | X, Y, S_x) > (Y | X, Y, S_y)$, the bars in Figure 17 should be negative for X and positive for Y if the similarity effect has occurred. Refer to the upper right-hand quadrant of Figure 17, in which both size and location are framed positively. Though it is not significant (see “S_y” in Table 2), we do see the correct trend for the similarity effect in the data: The relative probability of choosing X decreases between the S_x and S_y choice sets, while the relative probability of choosing Y increases. The magnitude of the similarity effect changes dramatically based on framing condition, as we would

expect based on the effects of framing outlined previously (see “-L, +S: S_y ” and “+L, -S: S_y ” in Table 2). We also see a consistent effect of emotion condition on the magnitude of the similarity effect across framing conditions, such that the Anger condition tends to have the largest similarity effect. In the incongruent framing conditions Fear also appears to have a consistently larger similarity effect than Control, though not as large as Anger. There are no significant three-way interactions between emotion, framing, and similarity of S in the regression model, and we therefore do not find evidence for the third hypothesis in the regression. Given the complexity of such an effect, however, the potential interactions of emotion and framing with the similarity effect will be primarily discussed in the modeling section below.

2.3.3.2.2 Reaction Time

Differences in reaction times were analyzed with a three-way ANOVA. Recall that the experiment included one trial per page on Qualtrics, meaning that participants would first select an apartment then click “Next” to finalize their answer and move on to the next page. Emotion condition, framing condition, and similarity of S served as factors in each model, with reaction time for page submission as the dependent variable. The reaction time scores were log transformed for the analyses. The results of the ANOVA are summarized in Table 3. The means and standard errors are depicted in Figure 18. There was no effect of emotion condition on page submission RT, $F(2, 511)=0.46, p=0.634$. The reaction

time data therefore do not support the second hypothesis that there are differences in deliberation between emotion conditions.

There was an effect of framing condition on page submission RT, $F(3, 1533)=9.15, p<0.001$, such that the negative location, negative size condition had the longest reaction times whereas the negative location, positive size condition had the shortest reaction times (see Figure 18). A post-hoc contrast revealed that the difference between the negative location, negative size condition and the adjacent condition of positive location, negative size was significant using a Bonferroni-corrected alpha value of 0.017, $t(2053.96)=2.50, p=0.012$. No other pairs were significantly different.

Though it is perhaps less theoretically interesting, it is important to note that there was a significant main effect of similarity of S on page submission RT, $F(1, 511)=29.11, p<0.001$, such that RT was greater when S was similar to X. This effect may be due to the fact that the order in which the alternatives were presented did not vary across trials, and comparing the small difference between X and S_x may have been more difficult than comparing the small difference between Y and S_y since X and S were always the furthest apart on screen (see Figure 10). There was also an interactive effect of similarity of S and framing condition, $F(3, 1533)=2.68, p=0.046$. It is possible that order effects may also explain this interaction; that is, the distance between Y and the current apartment's ratings may compensate for the advantage that Y has in reaction time due to its proximity to S when the framing condition is more complex (i.e., when the features are framed incongruently). Indeed, we see a difference in reaction times between similarity sets in the congruent framing

conditions, but not the incongruent framing conditions (see Figure 18). In future experiments we will be cautious to randomize the order in which the alternatives are presented.

2.3.3.3 Mathematical Modeling

The aim of the present study is to investigate the effects of discrete emotional states on preferential choice. Specifically, our goal was to determine whether particular emotional dimensions, valence and certainty, affected particular component processes underlying preferential choice, attentional deployment and accumulation threshold. Mathematical modeling offers a powerful method of uncovering hidden component processes, and is therefore an ideal tool for testing differences in component processes between different induced emotional states. Recall that the present experiment was initially simulated in two popular models of preferential choice: the Multialternative Decision Field Theory (MDFT) and the Multiattribute Linear Ballistic Accumulator (MLBA). The choice outcomes predicted by the MDFT are presented in Figure 5, and the choice proportions for the MLBA are presented in Figure 8. Figure 17 displays the choice outcomes that were observed in the actual experiment. Each figure summarized the choice proportions for each alternative in terms of the similarity effect, defined as the choice proportions in the (X, Y, S_y) choice set subtracted from the choice proportions in the (X, Y, S_x) choice set.

Both the MDFT and the MLBA made generally good predictions of the data. Both models correctly predicted that the similarity effect would occur when both

features were framed positively, as well which alternative would be most preferred in each of the incongruent framing conditions. However, the simulations that we conducted with theoretically motivated parameter values did not predict several of the observed effects. Neither model predicted that the Anger condition would exhibit the largest similarity effect in all framing conditions. Additionally, neither model predicted that the Control condition would also exhibit incongruent framing effects. We note that predictions regarding the Control condition should be taken with a grain of salt given the strong assumptions that we made regarding the complete neutrality of these participants. The most interesting discrepancy between the simulations and the observed data is the reversal of the similarity effect when both features were framed negatively. While the incorrect predictions for both the Anger and Control conditions may be a consequence of the parameter values we selected, the surprising effects of the negative location, negative size framing condition warrants deeper probing of the models themselves.

2.3.3.3.1 Four-Choice Simulations

One possible explanation of the reversed similarity effect in this framing condition is that the inclusion of ratings for an additional apartment that cannot be chosen, a novel modification to the similarity effect paradigm, may influence behavior on a deeper level than attentional deployment. Specifically, it is possible that participants are still including the current apartment in the deliberation process even though they know that it is not a viable option. To investigate this theory, we simulated the choice task in each model with four alternatives instead of

three while still preventing the model from selecting the fourth alternative. That is, ratings for apartments X, Y, S, and the current apartment C were entered into each model, but the decision process continued until either X, Y, or S (and not C) exceeded the decision threshold. See Figure 2 for relative rating values.

The predictions made by the MDFT in the four-choice scenario are presented in Figure 19. Specific parameter values can be found in Appendix A. Compared to the original three-choice MDFT predictions (Figure 5), it is still the case that when size and location are both framed positively participants in all conditions are predicted to exhibit a traditional similarity effect. It is also still the case that when size and location are framed incongruently participants in the Anger and Fear conditions are predicted to select the alternative that is rated best in the negatively framed feature, resulting in an increased similarity effect for X when location is framed negatively and size is framed positively and for Y when size is framed negatively and location is framed positively. This effect is still not predicted for participants in the Control condition, and participants in the Fear condition are still expected to have the most extreme effect.

Critically, however, the model now predicts that the similar alternative (X in the S_x choice set and Y in the S_y choice set) is most likely to be chosen when both features are framed negatively, resulting in a reversal of the traditional similarity effect. This reversal occurs as a result of the current apartment heavily dominating the three new apartments in the comparison process. Though each alternative now has an additional negative comparison in each feature, the preference strength of the similar alternative is harmed the least since C competes most with S along one

feature and the dissimilar alternative along the other. This allows the similar alternative to become the most likely choice because it does not suffer additional inhibition by C, and its preference strength is therefore still allowed to grow over time. However, neither the reversed similarity effect nor the standard similarity effect is predicted for Anger. This is likely because the low threshold for Anger only allows for the standard similarity effect to be diminished, not reversed. Predicted reaction times by the four-choice MDFT are presented in Figure 20, and mirror the predictions of the original three-choice MDFT with the exception that reaction times are now expected to be longest when both features are framed negatively, as observed in the data.

The predictions made by the MLBA in the four-choice scenario are presented in Figure 21. Specific parameter values can be found in Appendix B. There are no meaningful differences between the three- and four-choice versions of the MLBA. Compared to the original three-choice MLBA predictions (see Figure 8), it is again the case that a standard similarity effect is predicted for all conditions when both features are framed positively. It is also still the case that when size and location are framed incongruently participants in the Anger and Fear conditions are predicted to select the alternative that is rated best in the negatively framed feature, resulting in an increased similarity effect for X when location is framed negatively and size is framed positively and for Y when size is framed negatively and location is framed positively. This effect is still not predicted for participants in the Control condition, and participants in the Fear condition are still expected to have the most extreme effect. Unlike the four-choice MDFT, the four-choice MLBA does not predict a

reversal in the similarity effect when both features are framed negatively. Predicted reaction times by the four-choice MLBA are presented in Figure 22, and mirror the predictions of the original three-choice MLBA.

To summarize, the modified four-choice version of the MDFT performs better than the standard three-choice version while both versions of the MLBA perform similarly. Neither of the models captures the effects of Anger across framing conditions. Of particular importance, the four-choice MDFT predicts the reversal of the similarity effect when both features are framed negatively, but not the MLBA. The four-choice MDFT thus appears to best predict the choice proportions found in the actual data based on simulations alone. These predictions are however based on the theoretically motivated parameter values that we selected. It is possible that the MLBA may be able to account for this pattern of results using a different set of parameters. Though we are only able to rely on simulations of the MDFT, the MLBA can be fit to subject data to estimate parameter values. The results of the MLBA model fitting are described below.

2.3.3.3.2 MLBA Fitting

We utilized the four-choice version of the MLBA in our fitting procedures due to the general advantages of the four-choice scenario in simulations over the three-choice scenario. Because of our low within-subject sample size, the model was fit to data aggregated within emotion condition rather than to individuals; therefore only one set of parameter values is provided for each emotion condition. The best-fitting

parameter values for each condition are presented in Table 4. In addition to threshold and the parameter governing attention to negative framing (β_{negative}), the positive constant (I_0) as well as the parameters governing attention to positive differences (λ_p), negative differences (λ_n), and attention to size compared to location (β_{size}) were allowed to vary due to their relevance to the similarity effect. The full details of the fitting procedure are described in Appendix B.

The first hypothesis states that participants in a negative emotional state (Anger and Fear) would attend more to negatively framed features than participants who are not in a negative emotional state (Control). Participants in the Anger and Fear conditions were therefore expected to exhibit an increase in attention to negatively framed features. The recovered parameter values do not support the first hypothesis, as attention to negatively-framed features was estimated to be high for all conditions (see " β_{negative} " in Table 4). Anger was estimated to have the highest value (3.57), followed by Control (3.31) and Fear (3.25). This result suggests that attention is high for negatively framed features relative to positively framed features for all participants, regardless of emotion condition.

The second hypothesis states that the certainty associated with a participant's emotional state would affect the amount of time that a participant spends considering a given choice set, and consequently how systematically the features of each of the alternatives in the set are considered. Therefore, participants in an emotional state characterized by uncertainty, such as fear, were expected to consider the features of each of the alternatives in a more systematic fashion than participants in an emotional state characterized by certainty, such as anger. The

recovered differences in threshold do not support the second hypotheses (see “Threshold” in Table 4); instead, participants in the Anger condition were estimated to have the highest threshold (18.08), followed closely by participants in the Fear condition (16.47). Participants in the Control condition were estimated to have the lowest threshold by far (10.41). The difference in threshold between the Control condition and Anger and Fear conditions suggests that negative valence may be associated with threshold rather than uncertainty.

The third hypothesis states that differences in attentional deployment and deliberation across conditions would in turn affect the magnitude of the similarity effect. Simulated choice data and log-transformed reactions times based on the best-fitting parameters are presented in Figures 23 and 24, respectively. Figure 23 summarizes the choice proportions in terms of the similarity effect. Compare this figure to the subject data presented in Figure 17. The simulated data capture the preference for the alternative that performs best in the negatively-framed feature for all emotion conditions in incongruently-framed trials. Importantly however, the MLBA was still not able to reproduce the reversal of the similarity effect for trials in which both features were framed negatively. Next compare the simulated reaction time data based on the best-fitting parameters (Figure 24) to the subjects’ reaction times (Figure 18). The simulated reaction time data estimates Control as having particularly long reaction times that do not reflect the performance of Control participants in the subject data. It therefore does not appear that the recovered parameters do a good job of predicting the observed choice outcomes.

CHAPTER 3

DISCUSSION

Past research has shown that emotion affects preferential choice outcomes (see Schwarz, 2000 and So et al., 2015 for reviews). Though emotion is often defined one-dimensionally in the decision-making literature, it is a complex state comprised of several dimensions that have been shown to independently affect the component processes of decision-making. In particular, emotional valence has been shown to increase attention such that attention increases for mood-congruent information (Bower, 1981; Martin et al., 1991; Strauss & Allen, 2006), and situational certainty has been shown to affect deliberation such that that emotions with a high level of uncertainty are associated with a more systematic deliberation style (Bohner & Weinerth, 2001; Tiedens & Linton, 2001). The goal of the present study was to further research on emotion and preferential choice by investigating the concurrent effects of valence and certainty on component processes of decision-making using mathematical modeling. Specifically, we aimed to determine whether the effects of valence and certainty on attention and information accumulation threshold, respectively, would affect the magnitude of the similarity effect in a preferential choice scenario. The present study had three main hypotheses: first, that the valence associated with a participant's emotional state affects how attention is differentially deployed to features with positive or negative framing; second, that the certainty associated with a participant's emotional state affects how systematically they consider the features of each of the alternatives in the choice set; and third, that the concurrent effects of valence and certainty influences the similarity effect.

Participants first underwent an Anger emotion manipulation, a Fear emotion manipulation, or no emotion manipulation (Control). All participants then completed a preferential choice task that was designed to elicit the similarity effect. Each choice set contained three apartments that were rated along two features: size and location. To measure mood-congruent attention, the features were framed positively or negatively in terms of how they compared to a hypothetical current apartment that could not be chosen. A feature was “positively” framed when all of the alternatives were rated higher than the current apartment for that feature, and a feature was “negatively” framed when all of the alternatives were rated lower than the current apartment for that feature. This resulted in four framing conditions: positive location, positive size; positive location, negative size; negative location, positive size; and negative location, negative size.

The first hypothesis that Anger and Fear, but not Control, would exhibit increased attention for features that were framed negatively in the incongruent framing conditions was not supported. Instead, both the behavioral and modeling results suggest that all participants exhibited an increase for negatively framed features regardless of emotion condition. The second hypothesis that situational certainty would affect deliberation was weakly supported by the finding that Anger participants exhibited a greater likelihood of choosing the preferred alternative in a given choice set, as predicted by the standard three-choice version of the MDFT. However, the second hypothesis was not supported in the reaction time data, in which no differences were found, nor in the model fits, which suggested that

participants in the Anger and Fear conditions both exhibited higher thresholds than participants in the Control condition.

The third hypothesis that the magnitude of the similarity effect would differ between emotion conditions was not supported statistically, nor is it perfectly predicted by any of the models. However, there is a consistent trend throughout each framing condition in which participants in the Anger condition exhibited a greater similarity effect than participants in the Control or Fear conditions, and this effect was significant in both of the congruent framing conditions. Because Fear and Anger are both negative emotions that differ in certainty (Lerner & Keltner, 2000), the differing choice patterns between Fear and Anger highlight the need to study emotions as complex states rather than single emotional dimensions such as arousal or valence alone.

There was a surprising effect when both size and location were framed negatively in which the similarity effect reversed, and to a significantly larger extent for participants in the Anger condition. Though outside of the primary hypotheses of the present study, this is an intriguing result that to our knowledge has not been previously reported in the literature. Interestingly, a simple modification to the MDFT in which the current apartment was included in the deliberation process, but not allowed to be selected, predicted the reversal of the similarity effect for trials in which both features were framed negatively. Such a modification did not improve predictions in the MLBA. As previously discussed, as an alternative to the MDFT's account, it is also possible that participants are heuristically choosing the apartment that never suffers the greatest "loss" in either size or location in comparison to the

current apartment. Regardless, this effect suggests that the framing manipulation influenced deliberation on a deeper level than its intended effects on attentional deployment.

The observed reversal of the similarity effect has multiple implications for the decision-making literature. At minimum, the MDFT simulations suggest that researchers should be cognizant of the potential presence, and influence, of unintended or “illusory” alternatives when designing preferential choice tasks, either in their stimuli or from participants’ own experiences. For example, in a paradigm in which a participant is asked to choose a new camera for herself, the participant’s behavior may be influenced by the quality of the camera that she actually owns. On a more theoretical level, this finding may serve as an evaluative measure for models of preferential choice as it appears to serve as a distinguishing factor between the MDFT and the MLBA in the present study. Future model development may benefit from accounting for the effects of illusory alternatives on preferential choice behavior. Given these implications it is clear that further and more targeted study of this effect is warranted.

The present study has a few limitations. First, a technical error invalidated one of the expected value conditions, which cut the within-subjects sample size by half. Even with these trials, however, the sample size would not be high enough to calculate informative choice proportions for each participant in each framing condition, as done in previous research on the similarity effect (e.g., Trueblood et al., 2014). The low number of trials was decided upon in order to minimize the probability of the fragile emotion manipulation wearing off before the choice task

was complete. Future studies may consider striking more of a balance between manipulation effect concerns and the need for high within-subjects power. The results of the present study also suggest that behavior was affected by the fixed order in which alternatives were presented, as participants took significantly less time to respond to trials in which the similar alternatives in a set were adjacent. Future studies should also be cautious to randomize the order in which alternatives are presented. Lastly, it is possible that no differences were found in the reaction time data due to the potential increase in variability of reaction times collected in online studies as a result of variability in the technology used by participants to access the study. An in-person replication of the present study may be informative in this regard.

The results of the present study did not provide clear and full support for all three hypotheses. However, they do support the merits of targeting the interactions of underlying mechanisms in studies of complex processes. Our results suggest that attention, a component process of decision-making, had large effects on choice outcomes. Anger and Fear, two emotional states that are similar in valence but not certainty, exhibited differing choice patterns. Mathematical modeling also proved to be a useful method of studying the effects of interest. Though neither the MDFT nor the MLBA could predict all of the observed patterns in the data, the MDFT offered an account of the reverse similarity effect and both models can explain the effects of attention on choice outcomes in the incongruent framing conditions. Future studies are urged to pursue research on emotion and decision-making that emphasizes the potentially multiple interactions of component states and processes.

Table 1: Non-target Aggregate Groups in the DES

Group	Items	Cronbach's Alpha
Anxious	Anxious Tense Nervous	.96
Gleeful	Warm-Hearted Gleeful Elated	.96
Happy	Joyful Amused Happy	.94
Sad	Sad Down-Hearted Blue	.97
Surprised	Surprised Amazed Astonished	.88
Disgusted	Disgusted Turned-Off Repulsed	.96
Disdainful	Disdainful Scornful Contemptuous	.98

Table 2: Results of Multinomial Logistic Regression: Choice ~ Emotion:Framing:Similarity

	X / S			Y / S		
	β	OR	SE	β	OR	SE
Intercept	** 0.59	1.80	0.19	** 0.57	1.78	0.19
Anger	* -0.55	0.58	0.28	-0.21	0.81	0.27
Fear	-0.26	0.77	0.28	-0.05	0.94	0.28
-L, -S	-0.06	0.94	0.28	-0.13	0.88	0.28
-L, +S	-0.08	0.92	0.34	*** 1.22	3.39	0.31
+L, -S	***-1.09	0.33	0.26	***-1.41	0.24	0.28
S _y	0.39	1.48	0.29	0.32	1.37	0.29
Anger: -L, -S	* 0.96	2.61	0.40	0.27	1.31	0.40
Fear: -L, -S	0.15	1.17	0.39	-0.23	0.79	0.39
Anger: -L, +S	-0.00	0.99	0.49	0.02	1.03	0.42
Fear: -L, +S	-0.17	0.84	0.49	-0.16	0.85	0.43
Anger: +L, -S	0.16	1.17	0.38	-0.30	0.74	0.39
Fear: +L, -S	0.19	1.21	0.38	-0.02	0.98	0.39
Anger: S _y	0.37	1.45	0.41	-0.08	0.92	0.41
Fear: S _y	-0.10	0.90	0.41	-0.26	0.77	0.41
-L, -S: S _y	-0.26	0.78	0.41	0.26	1.30	0.41
-L, +S: S _y	***-1.83	0.16	0.45	***-2.33	0.09	0.41
+L, -S: S _y	***-1.79	6.03	0.41	* 0.99	2.72	0.44
Anger: -L, -S: S _y	-0.47	0.62	0.59	0.18	1.20	0.59
Fear: -L, -S: S _y	0.35	1.42	0.58	0.35	1.42	0.58
Anger: -L, +S: S _y	-0.19	0.83	0.65	-0.37	0.69	0.58
Fear: -L, +S: S _y	-0.45	1.58	0.64	0.09	1.09	0.58
Anger: +L, -S: S _y	0.00	1.00	0.58	0.35	1.43	0.64
Fear: +L, -S: S _y	0.32	1.37	0.59	0.79	2.19	0.63

Note: The baseline model predicts the probability of choosing S given that the individual in the Control condition, S was similar to X, and both size and location were framed positively. Only the EV=2.5 condition was used.

* $p < 0.05$; ** $p < 0.01$; *** $p < 0.001$

Table 3: Results of Three-Way ANOVA: Page Submit RT ~ Emotion:Framing:Similarity

	First Selection RT				
	df	SS	MS	F	p
Emotion	2	1.50	0.74	0.46	0.634
Framing	3	6.20	2.08	9.15 ***	<0.001
Similarity	1	5.28	5.28	29.11 ***	<0.001
Emotion*Framing	6	0.60	0.10	0.45	0.845
Emotion*Similarity	2	0.39	0.19	1.08	0.340
Framing*Similarity	3	1.70	0.56	2.68	* 0.046
Emotion*Framing*Similarity	6	1.50	0.25	1.19	0.309

Note: Reaction time data is log-transformed. Only the EV=2.5 condition was used.

* $p < 0.05$; ** $p < 0.01$; *** $p < 0.001$

Table 4: Best-fitting Parameter Values from the Four-Choice MLBA

Condition	Threshold	λ_p	λ_n	I_0	β_{size}	β_{negative}	ML
Anger	18.079	1.519	3.192	0.347	1.092	3.567	-5351.08
Fear	16.472	1.472	3.022	0.212	1.093	3.250	-5648.20
Control	10.407	1.848	2.880	< 0.001	0.999	3.310	-7873.00

Note: The λ_p and λ_n parameters represent the weights on positive and negative comparisons, respectively. The I_0 parameter is the positive constant that is added to the average drift rate of each alternative. The β_{size} and β_{negative} parameters represent the weights on size and negative framing, respectively. ML is maximum log likelihood.

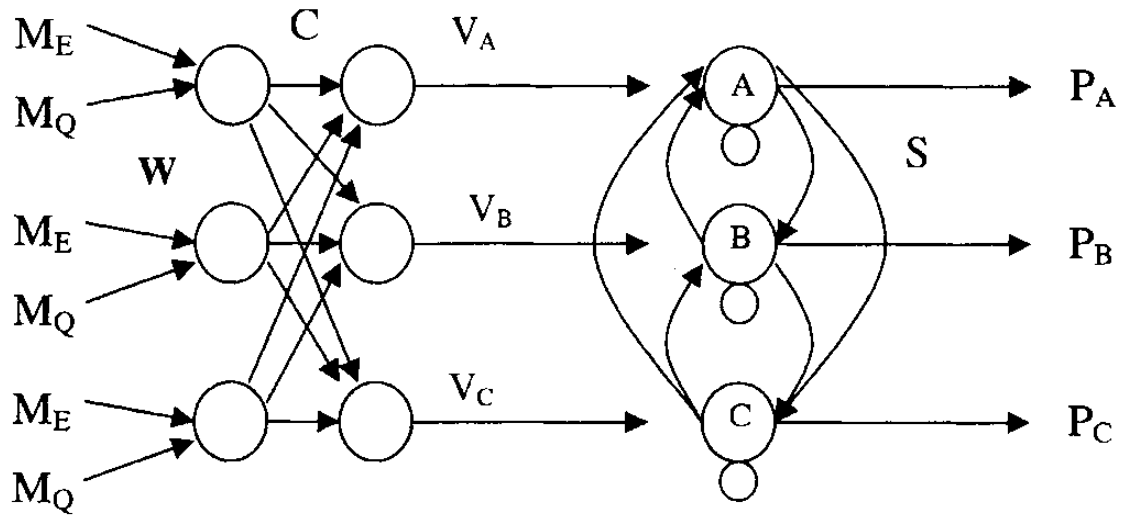

Figure 1: Multialternative Decision Field Theory

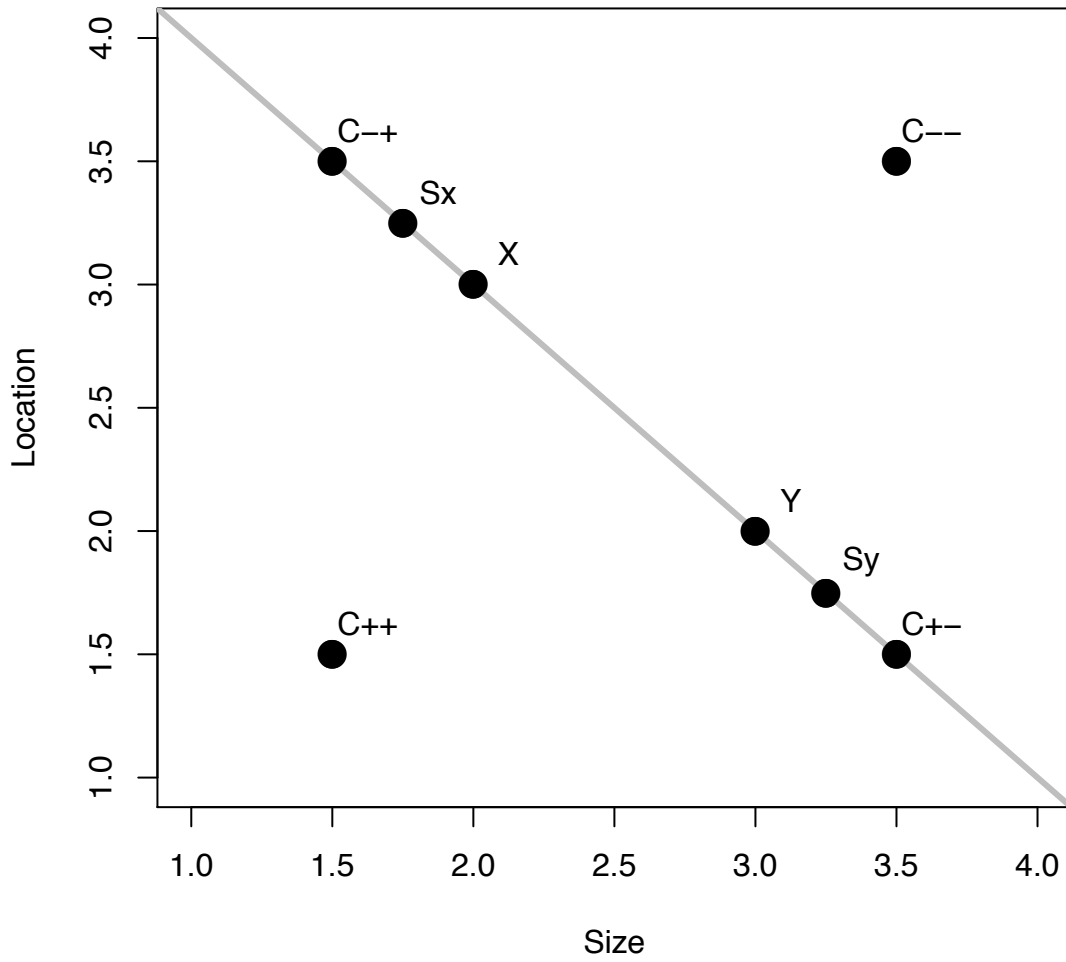

Figure 2: Choice Stimuli Feature Ratings

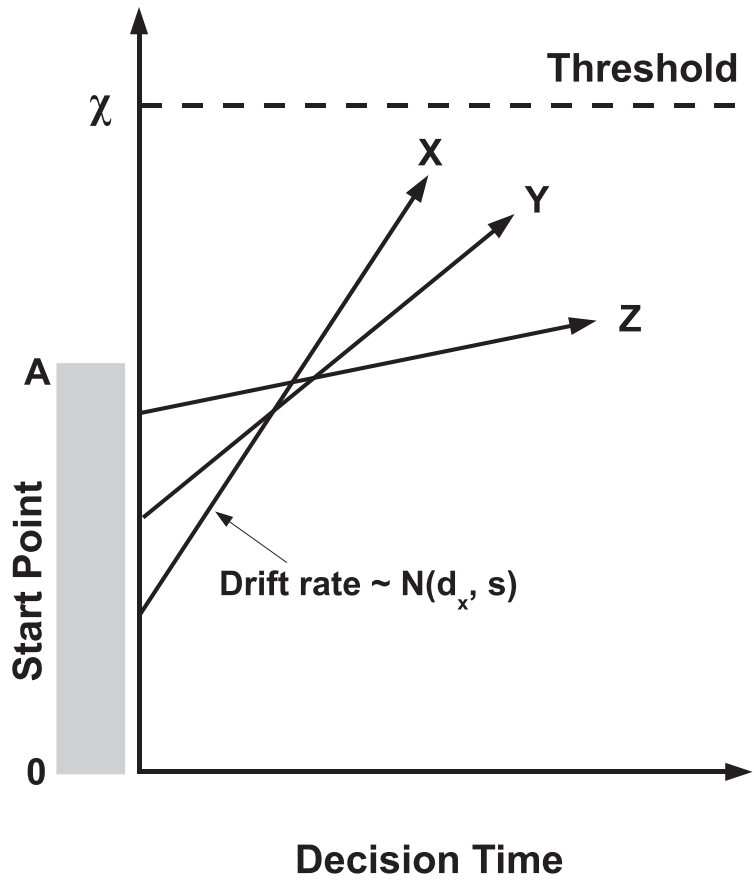

Figure 3: Multiattribute Linear Ballistic Accumulator

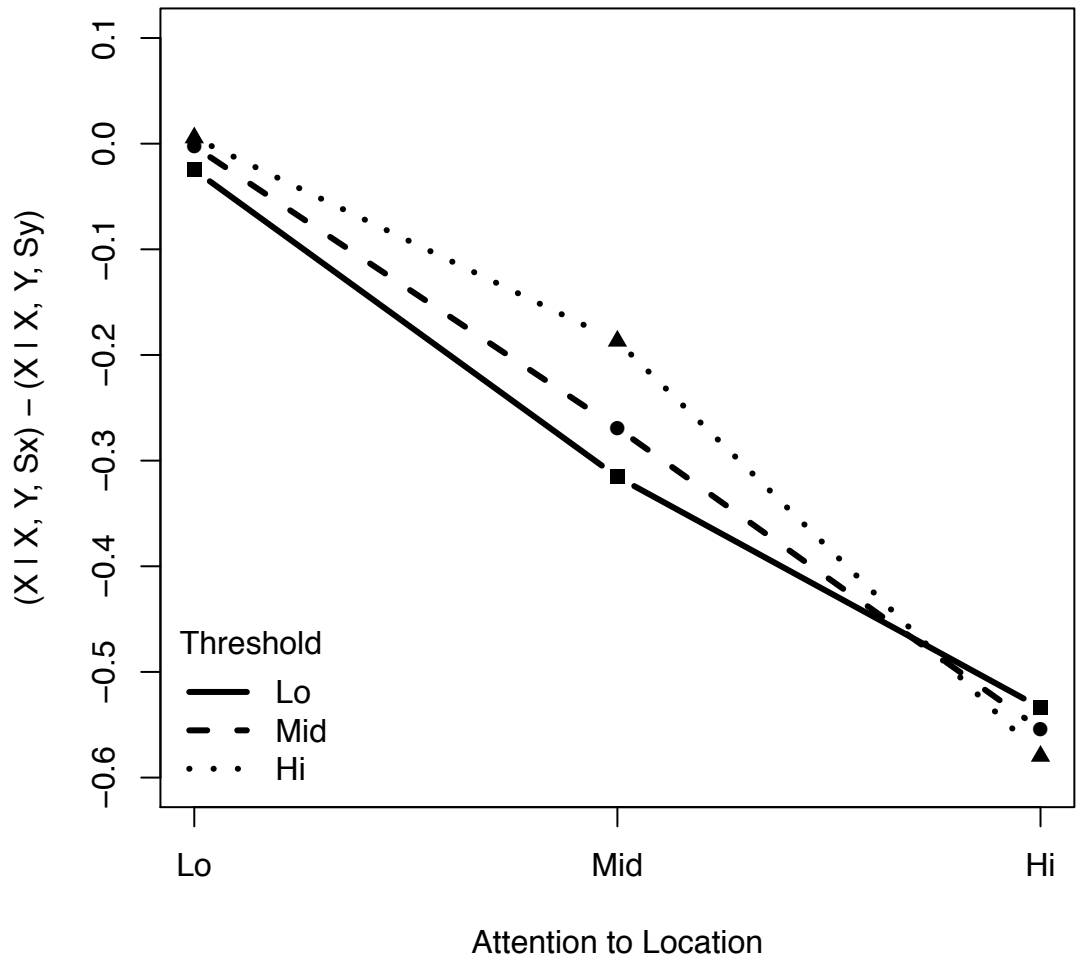

Figure 4: Influence of Attention and Accumulation Threshold on the Similarity Effect as Predicted by the MDFT

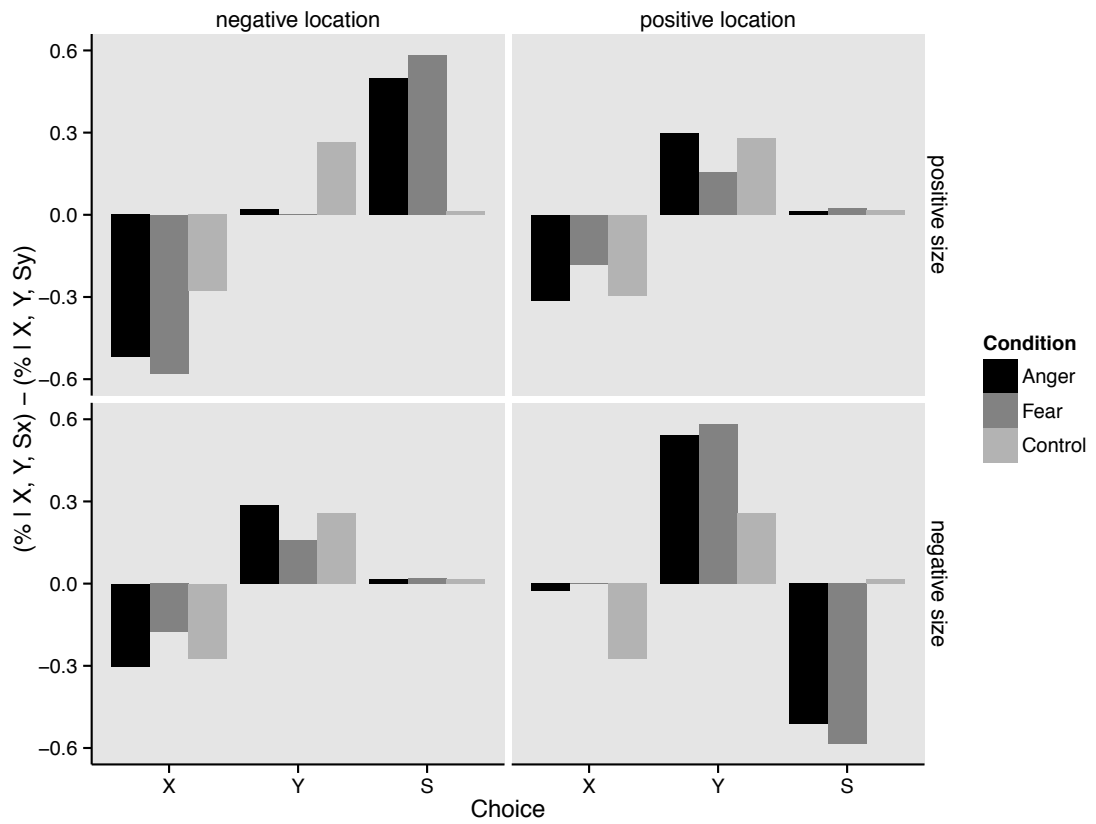

Figure 5: Predicted Effects of Emotion on Choice by the Three-Choice MDFT

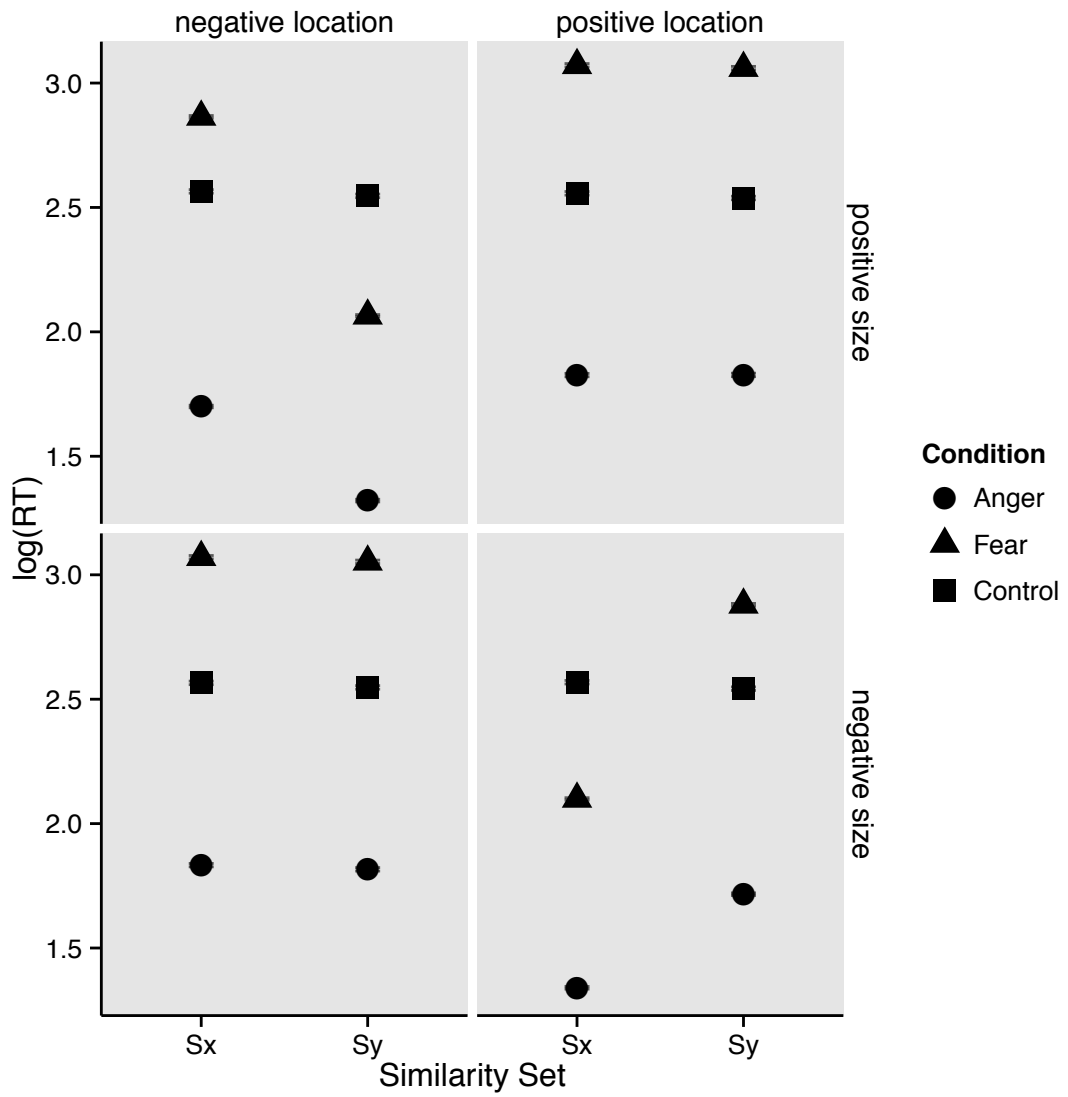

Figure 6. Predicted Effects of Emotion on RT by the Three-Choice MDFT

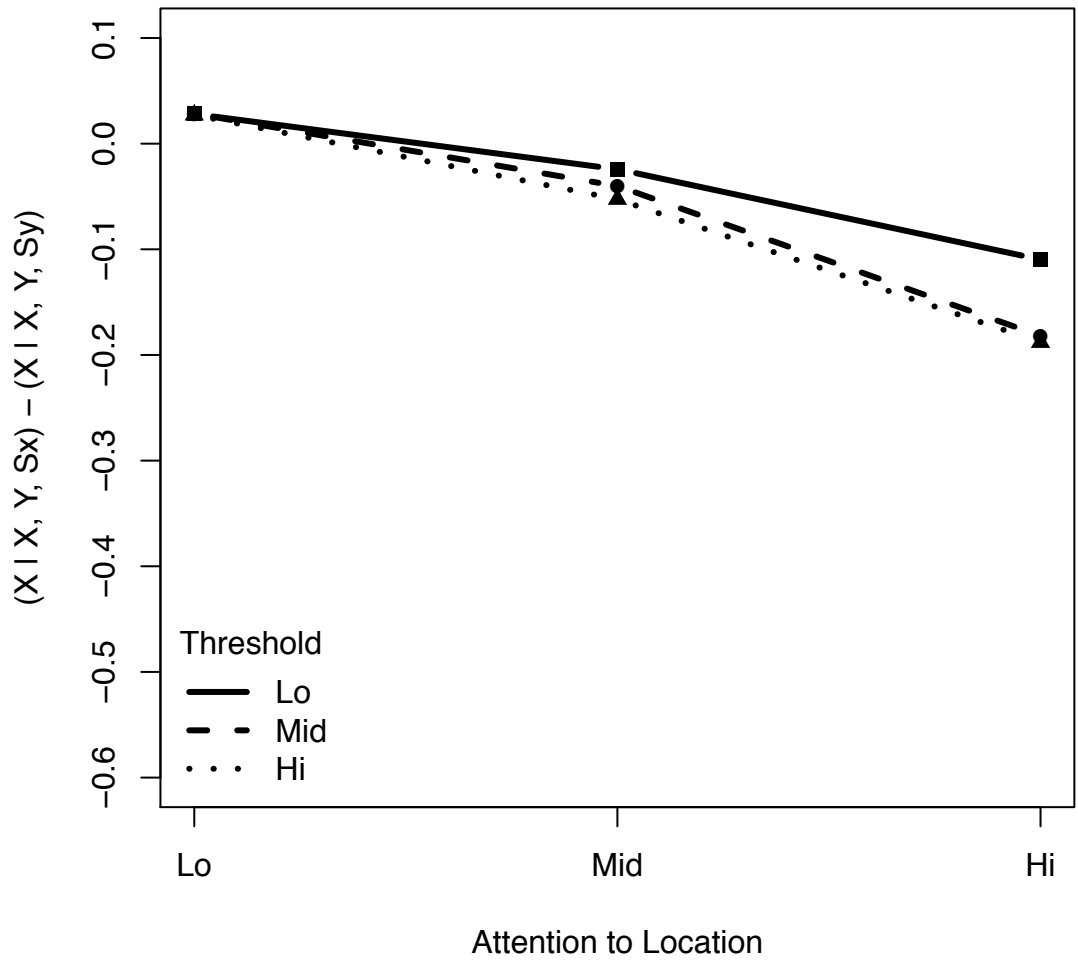

Figure 7: Influence of Attention and Accumulation Threshold on the Similarity Effect as Predicted by the MLBA

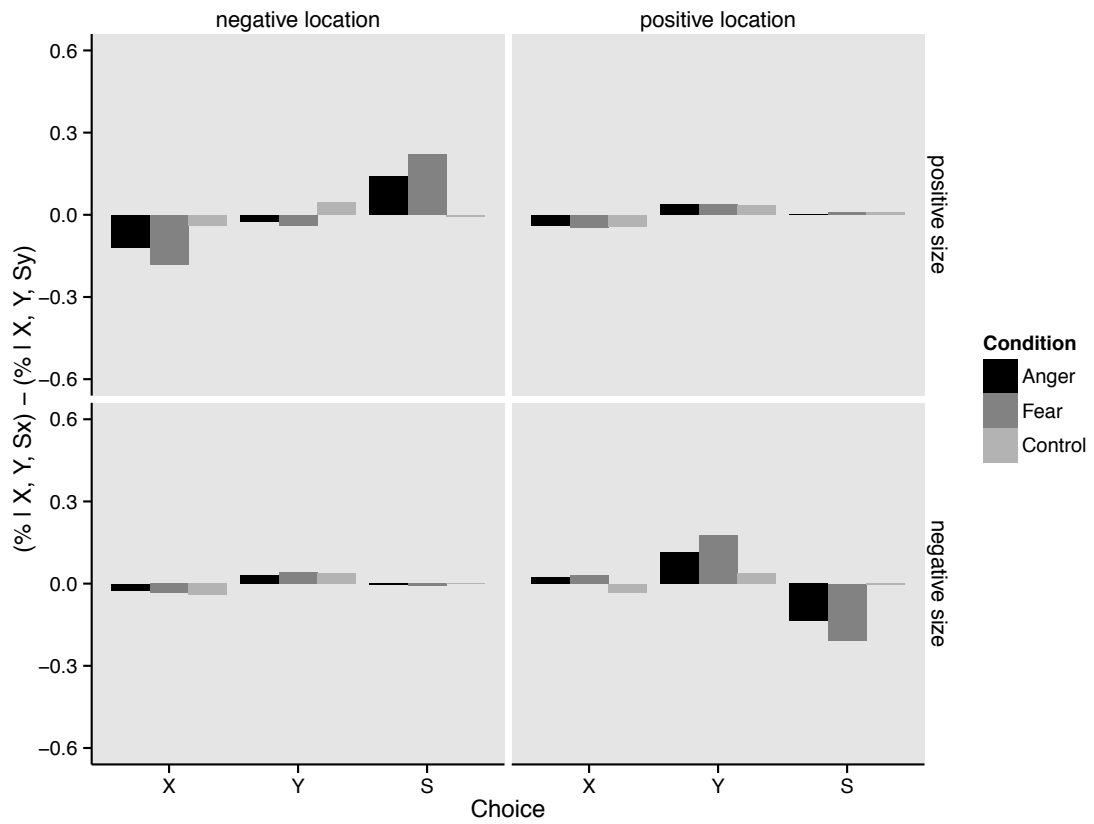

Figure 8: Predicted Effects of Emotion on Choice by the Three-Choice MLBA

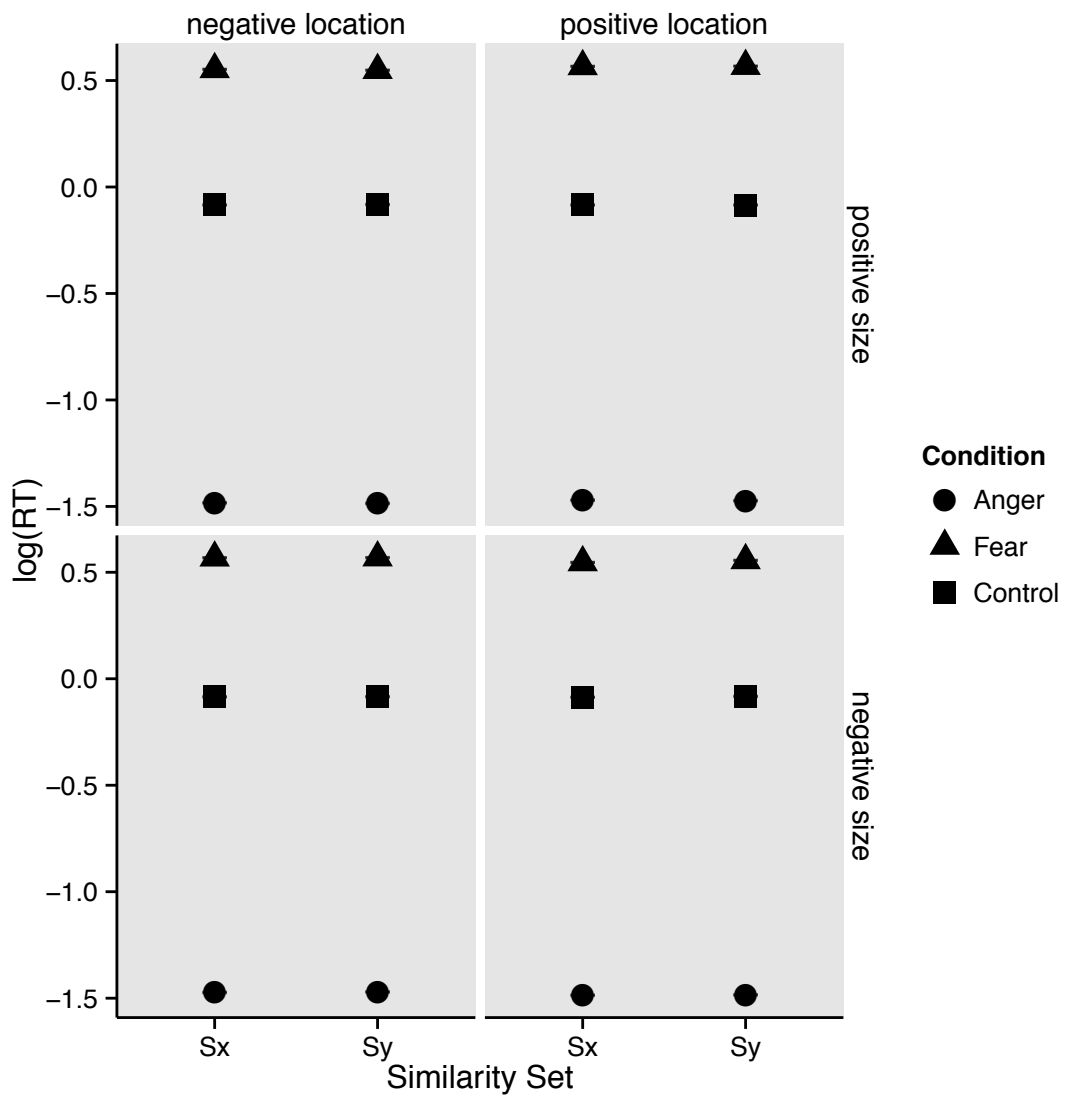

Figure 9: Predicted Effects of Emotion on RT by the Three-Choice MLBA

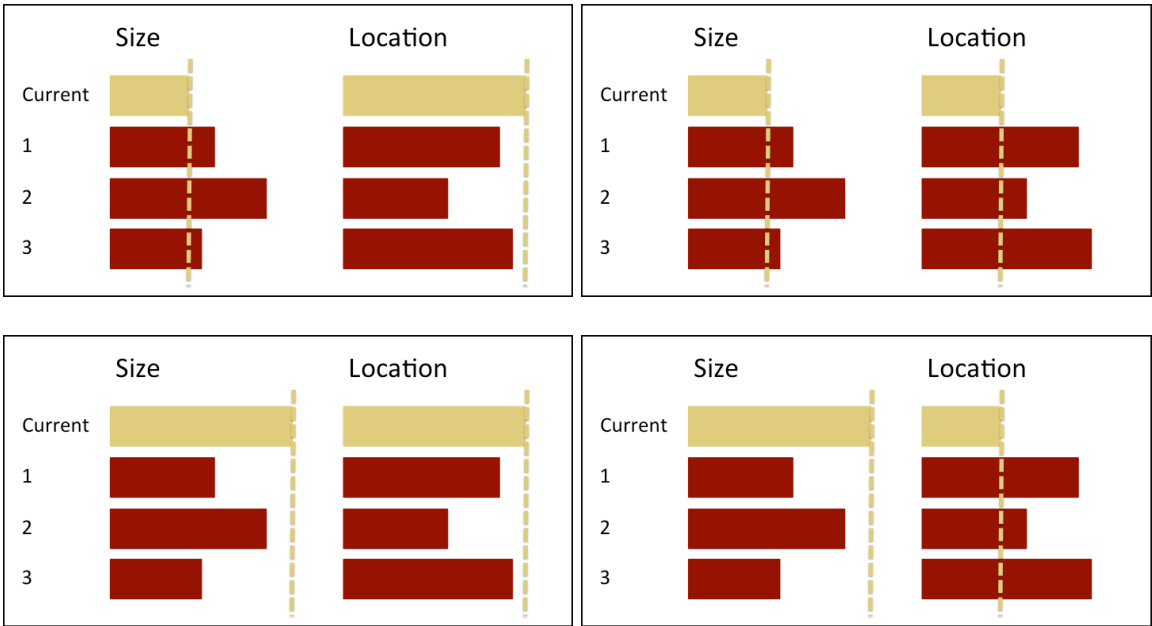

Figure 10: Sample Stimuli

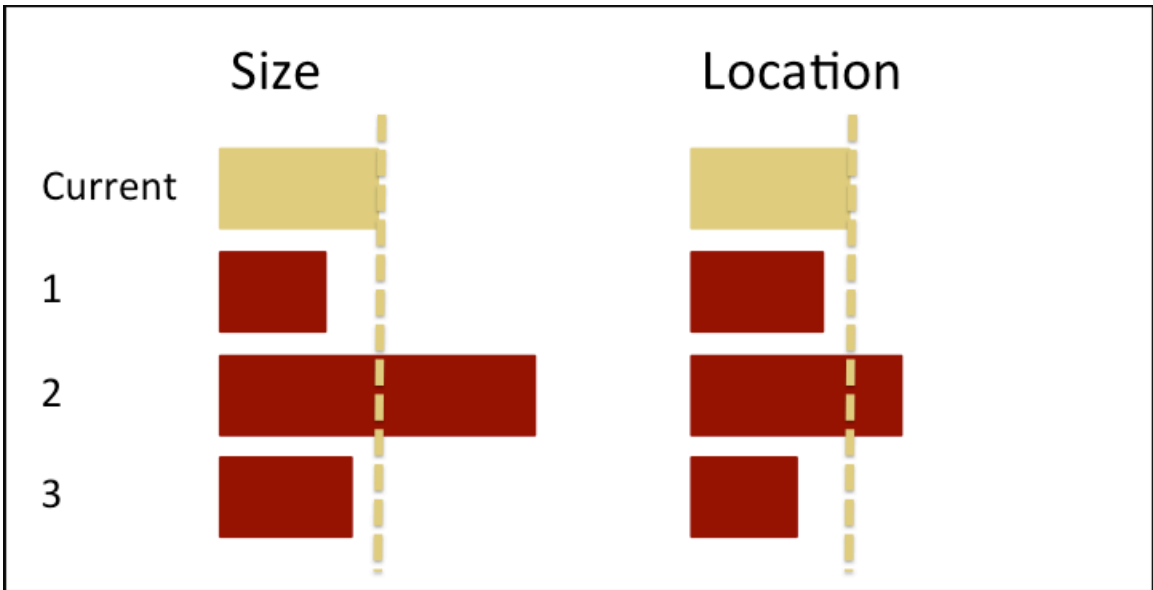

Figure 11: Sample Catch Trial

DES Mean Ratings

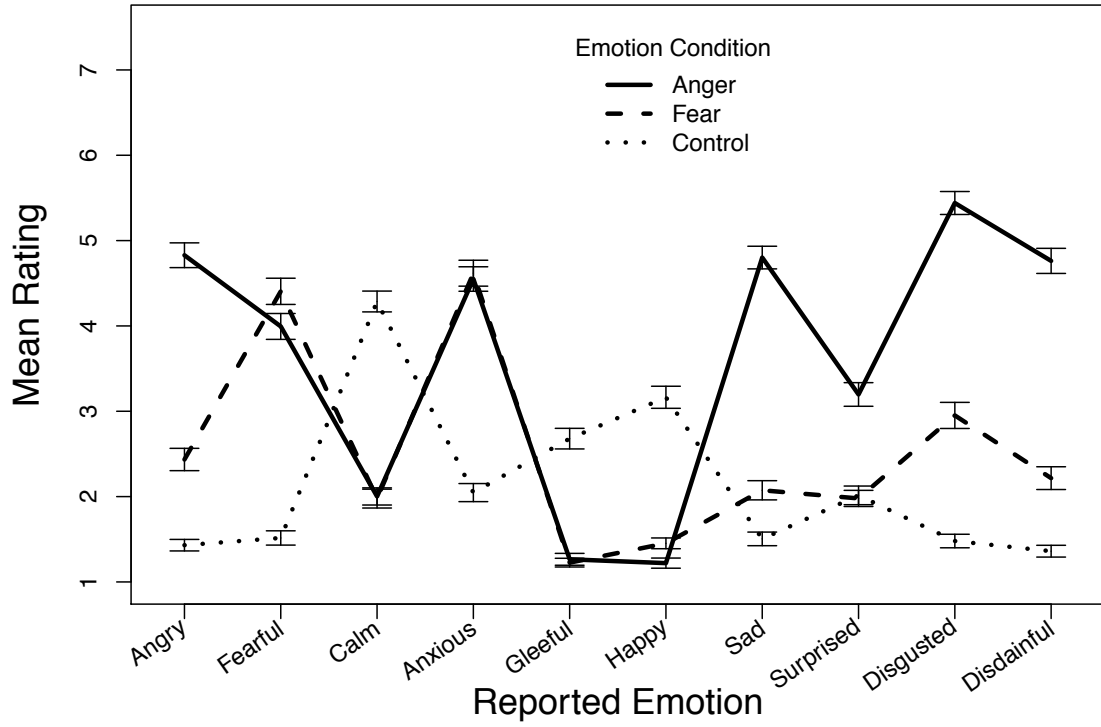

Figure 12: Average DES Ratings

DES Positive/Negative Subscale Mean Ratings

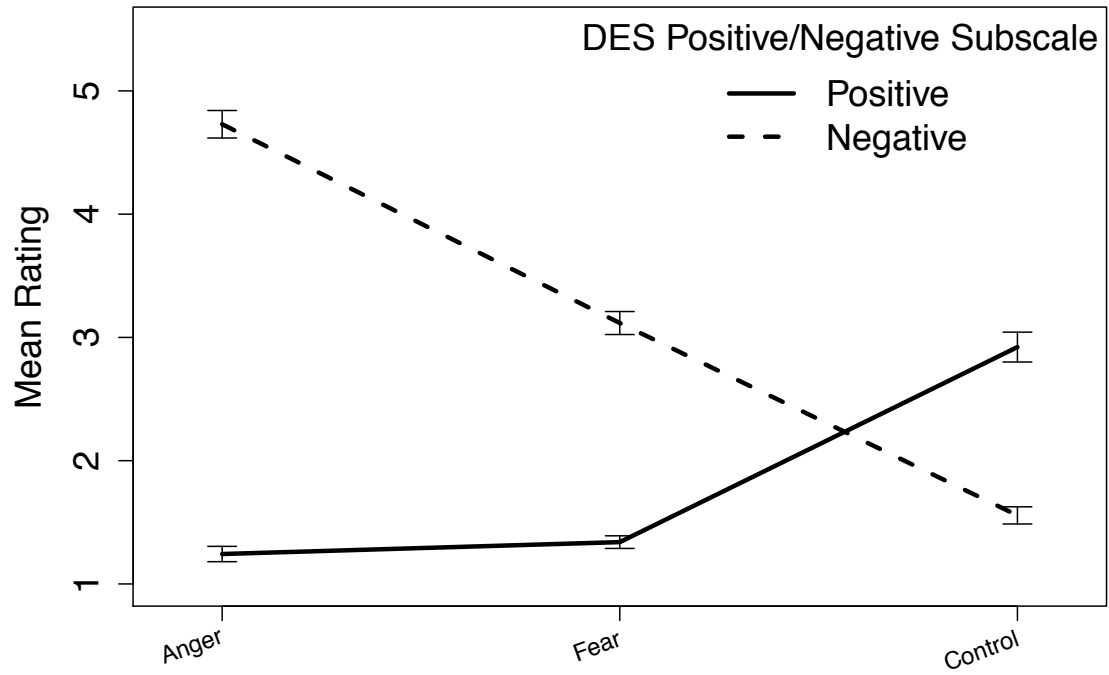

Figure 13: Average DES Positive/Negative Subscale Ratings

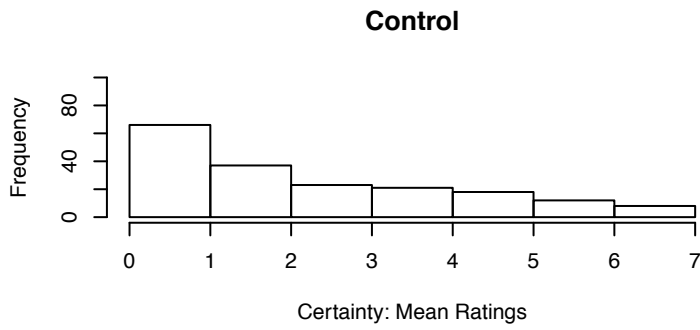
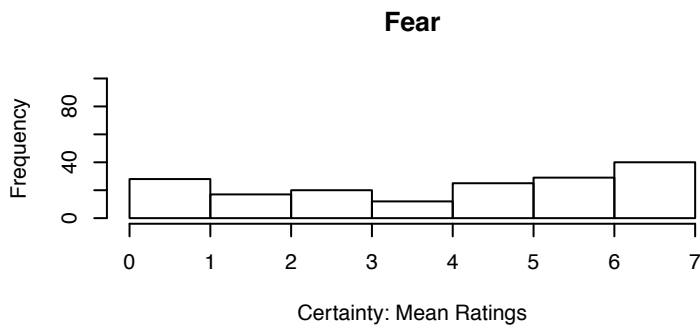
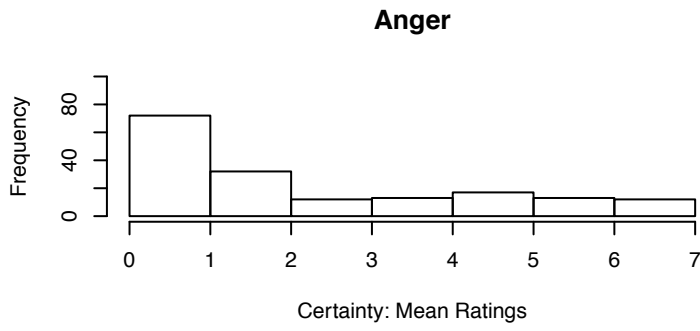

Figure 14: Distributions of Average Responses to the Certainty Items by Condition

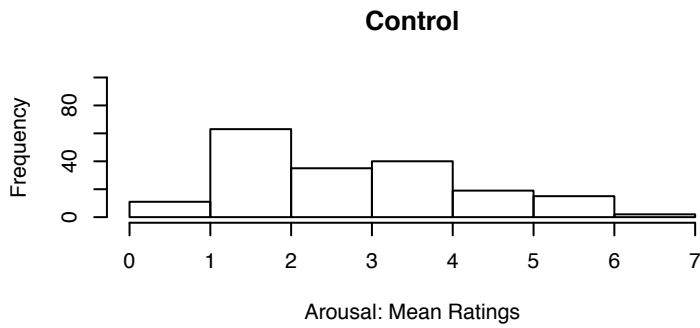
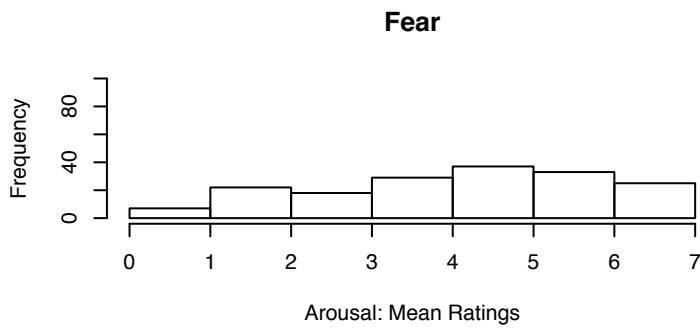
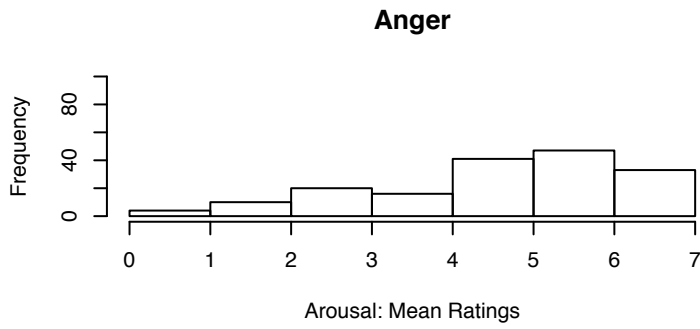

Figure 15: Distributions of Average Responses to the Arousal Items by Condition

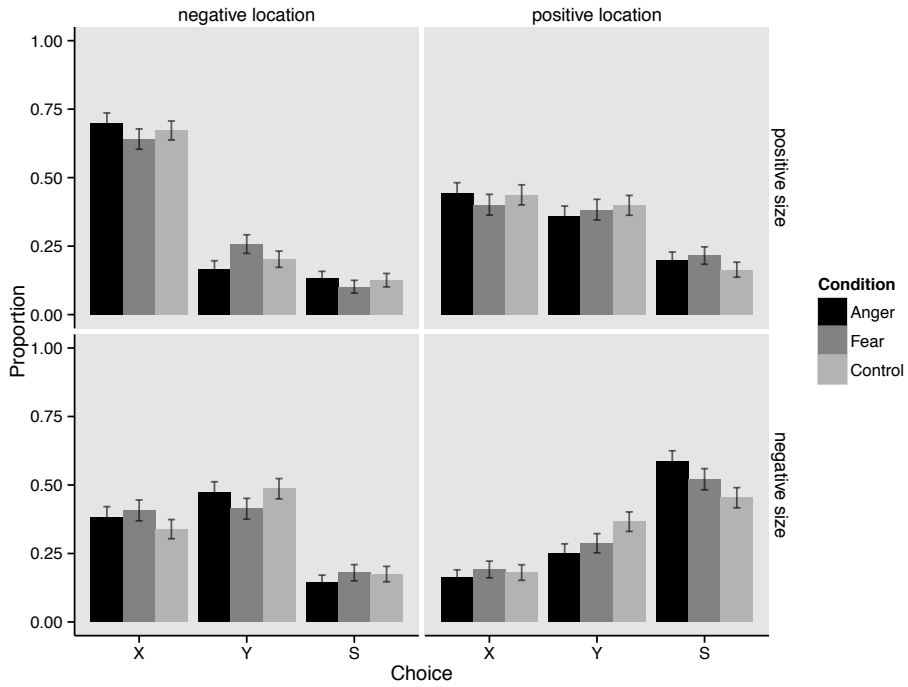
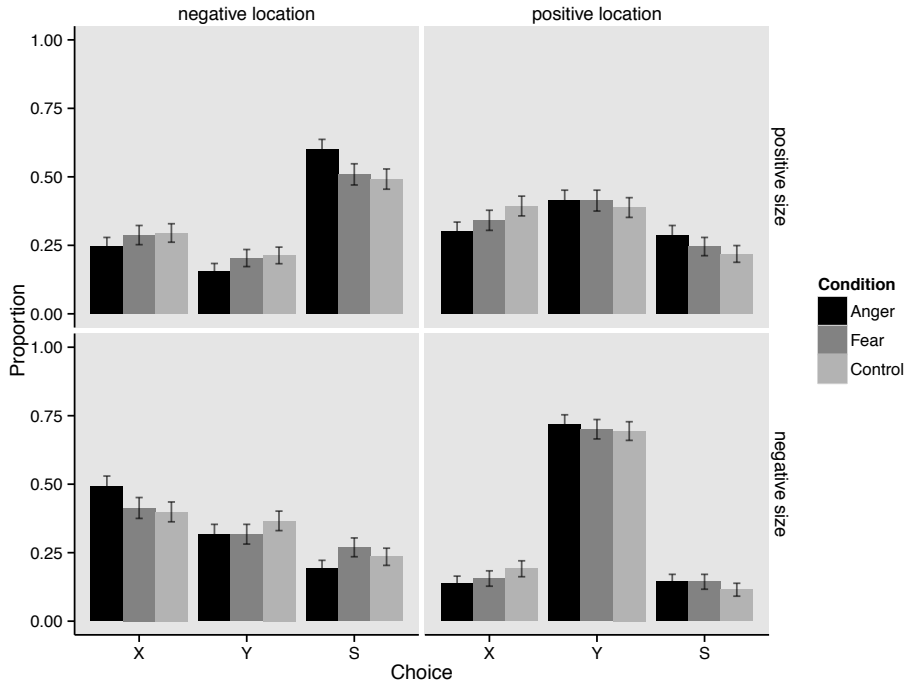

Figure 16: Choice Proportions

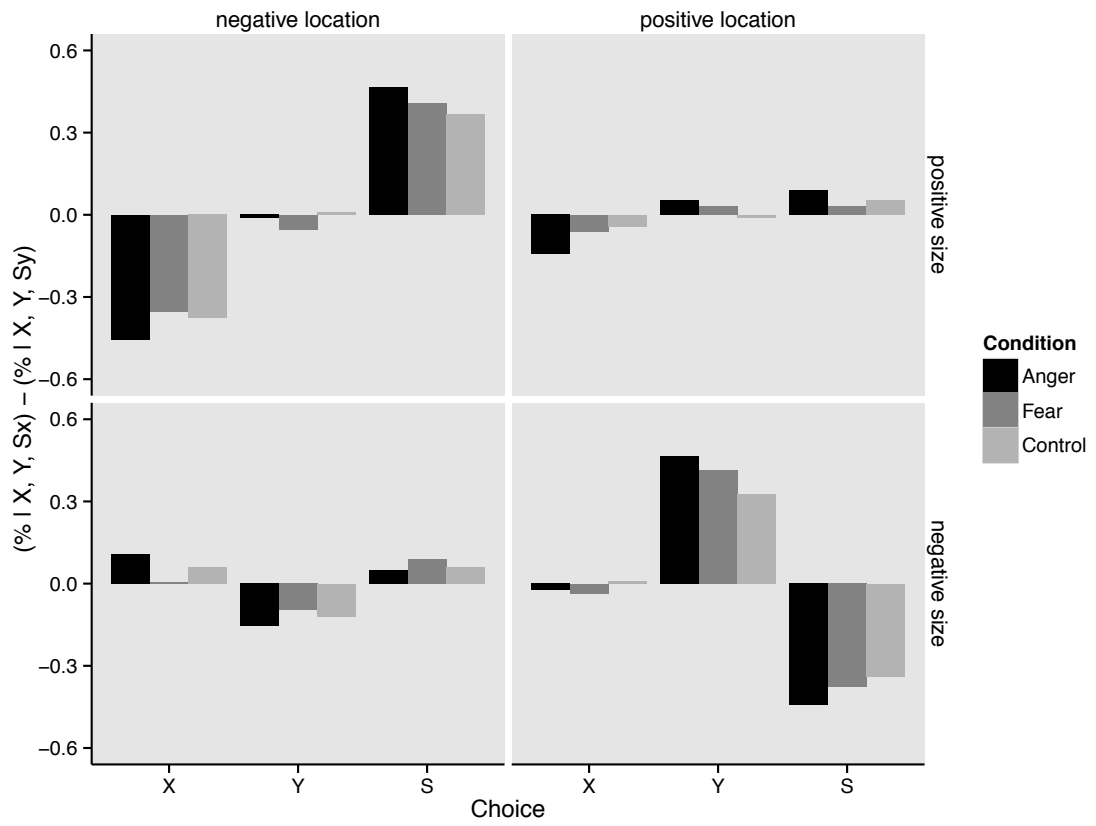

Figure 17: Differences in Choice Proportions Between S Similarity Levels

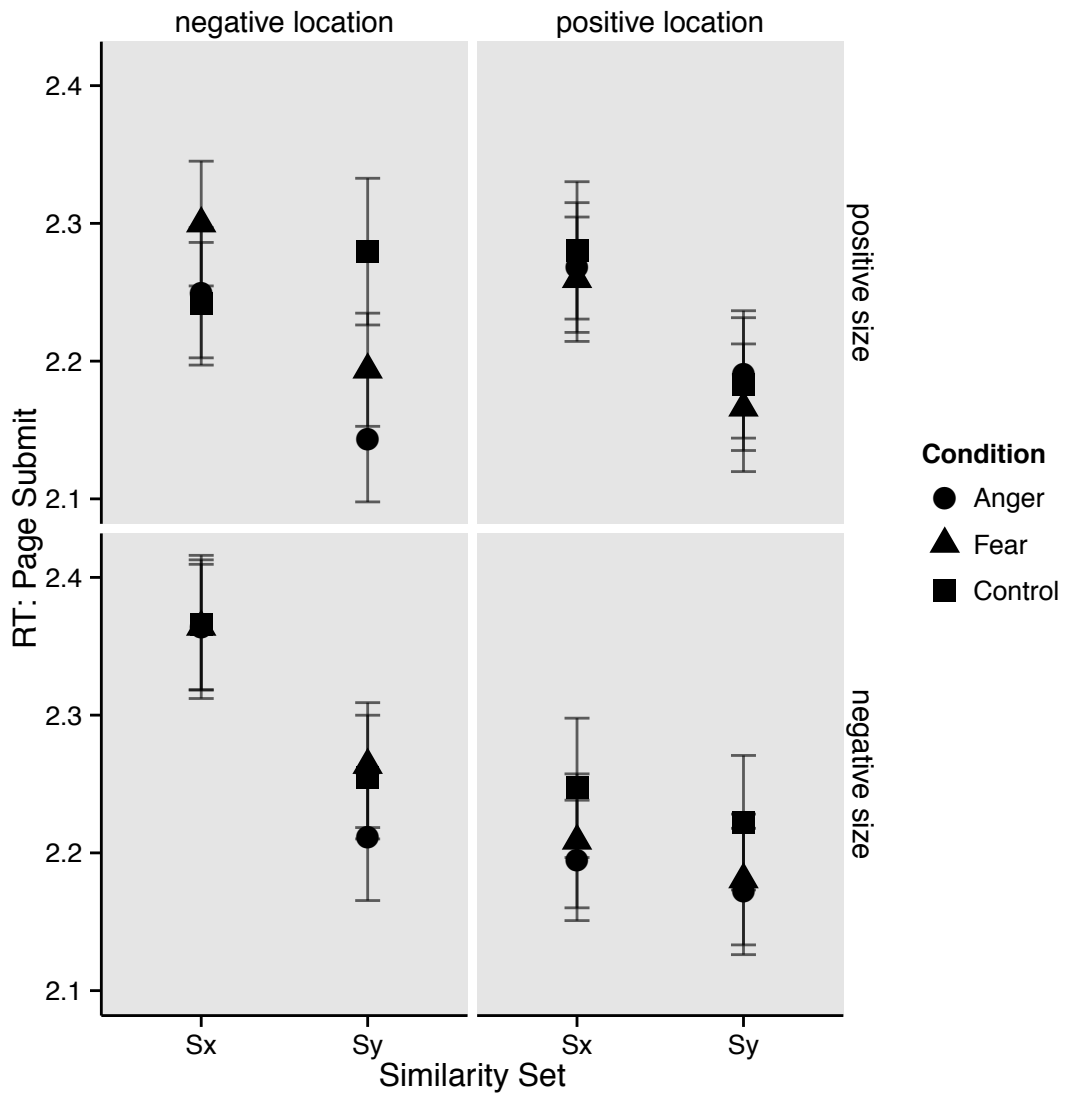

Figure 18: Log-transformed Reaction Times for the Response Submission

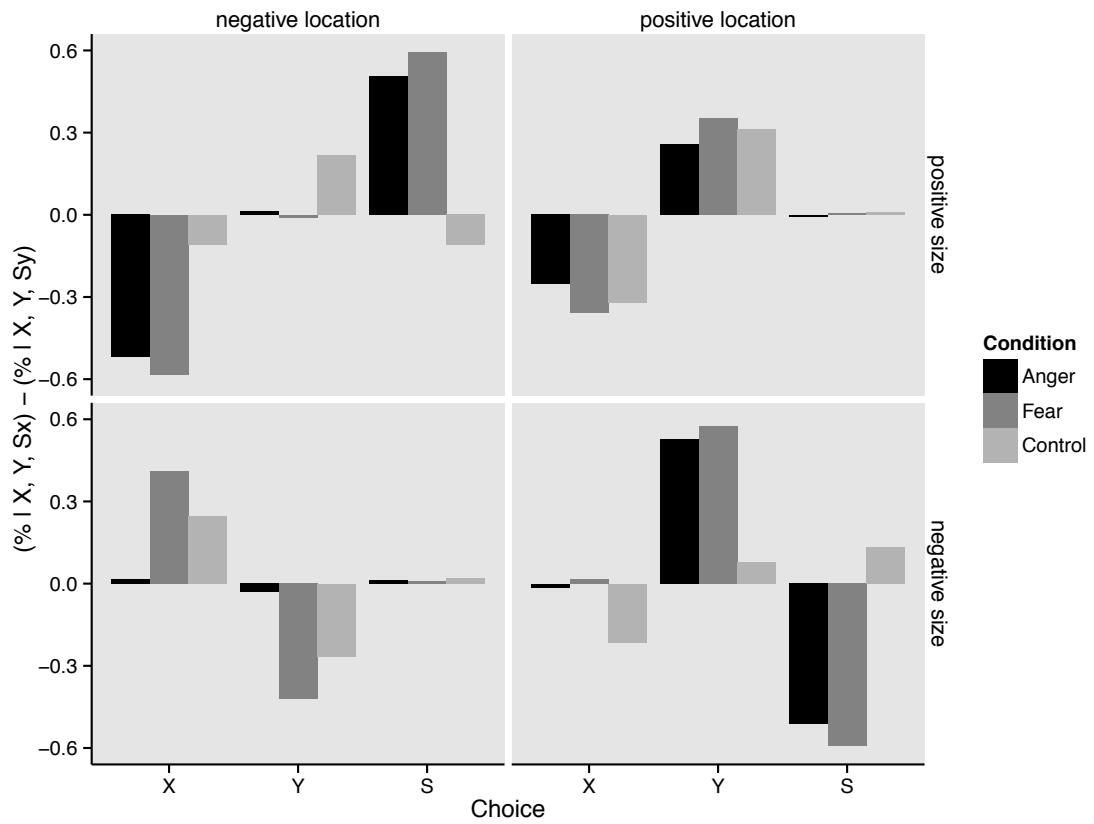

Figure 19: Predicted Effects of Emotion on Choice by the Four-Choice MDTT

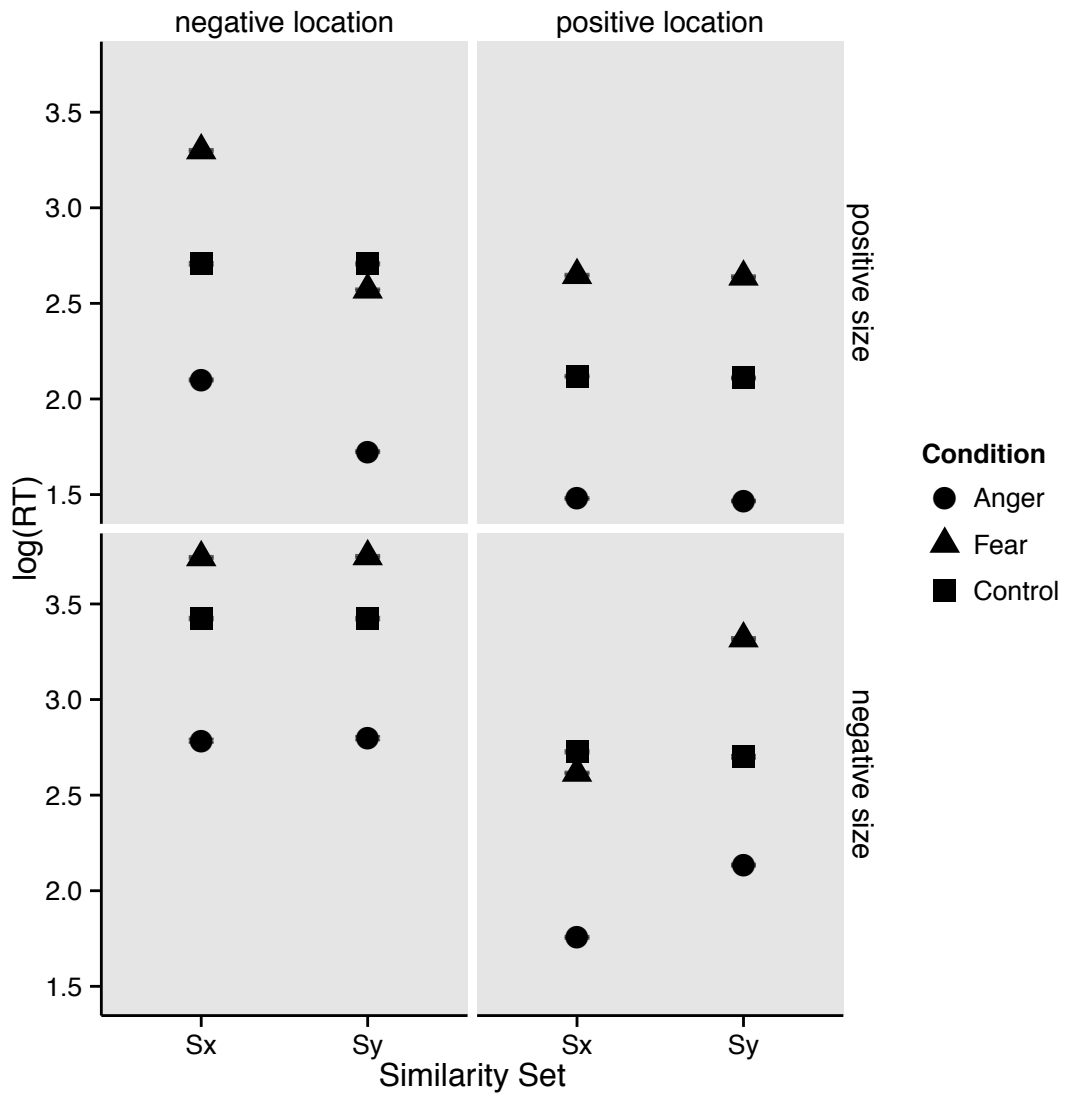

Figure 20: Predicted Effects of Emotion on RT by the Four-Choice MDFT

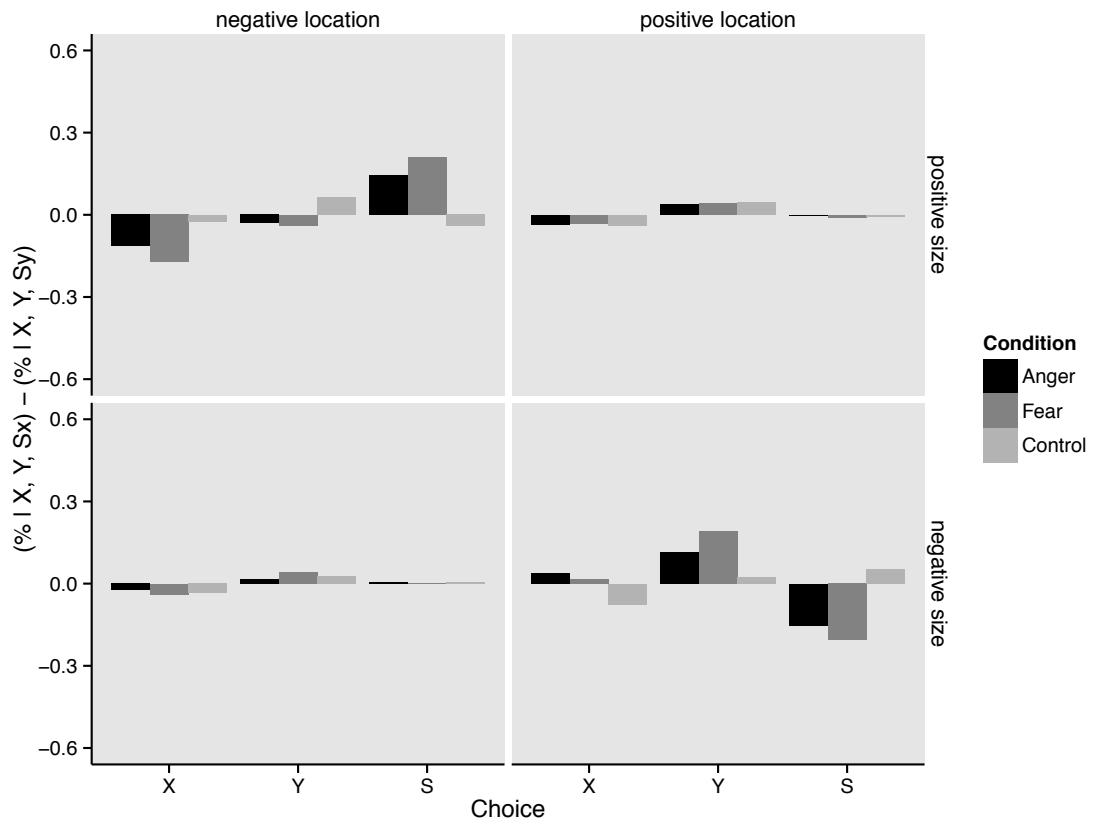

Figure 21: Predicted Effects of Emotion on Choice by the Four-Choice MLBA

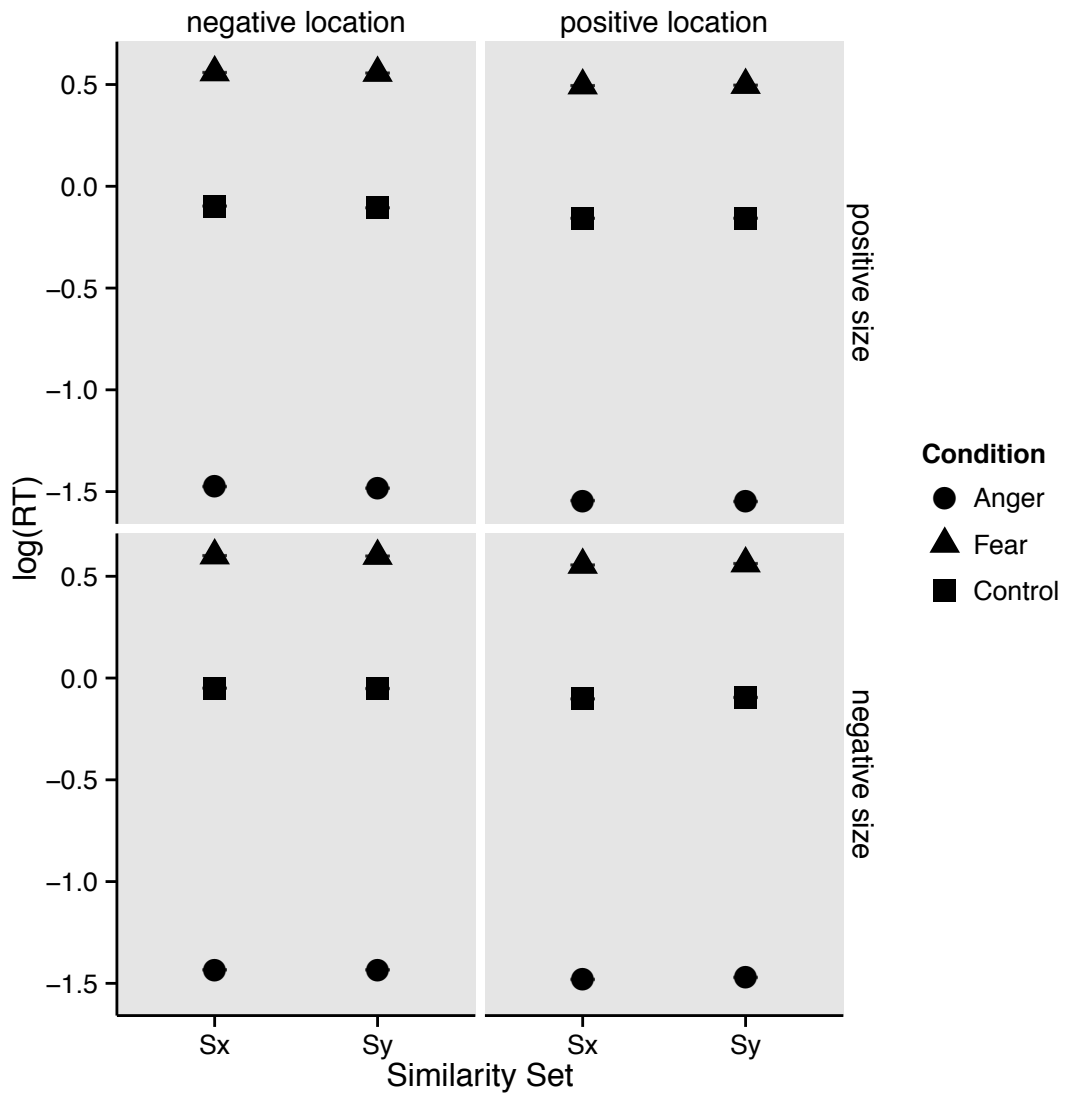

Figure 22: Predicted Effects of Emotion on RT by the Four-Choice MLBA

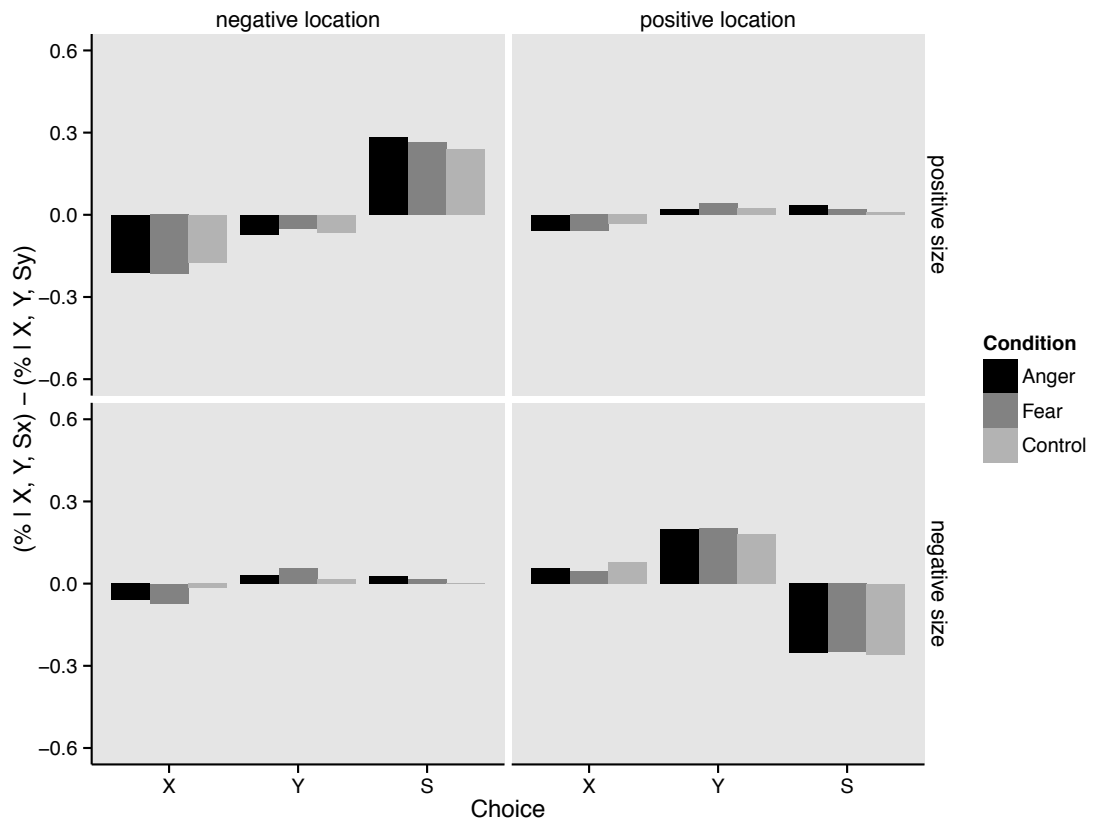

Figure 23: Differences in Choice Proportions Between S Similarity Levels, Based on the Best-Fitting MLBA Parameter Values

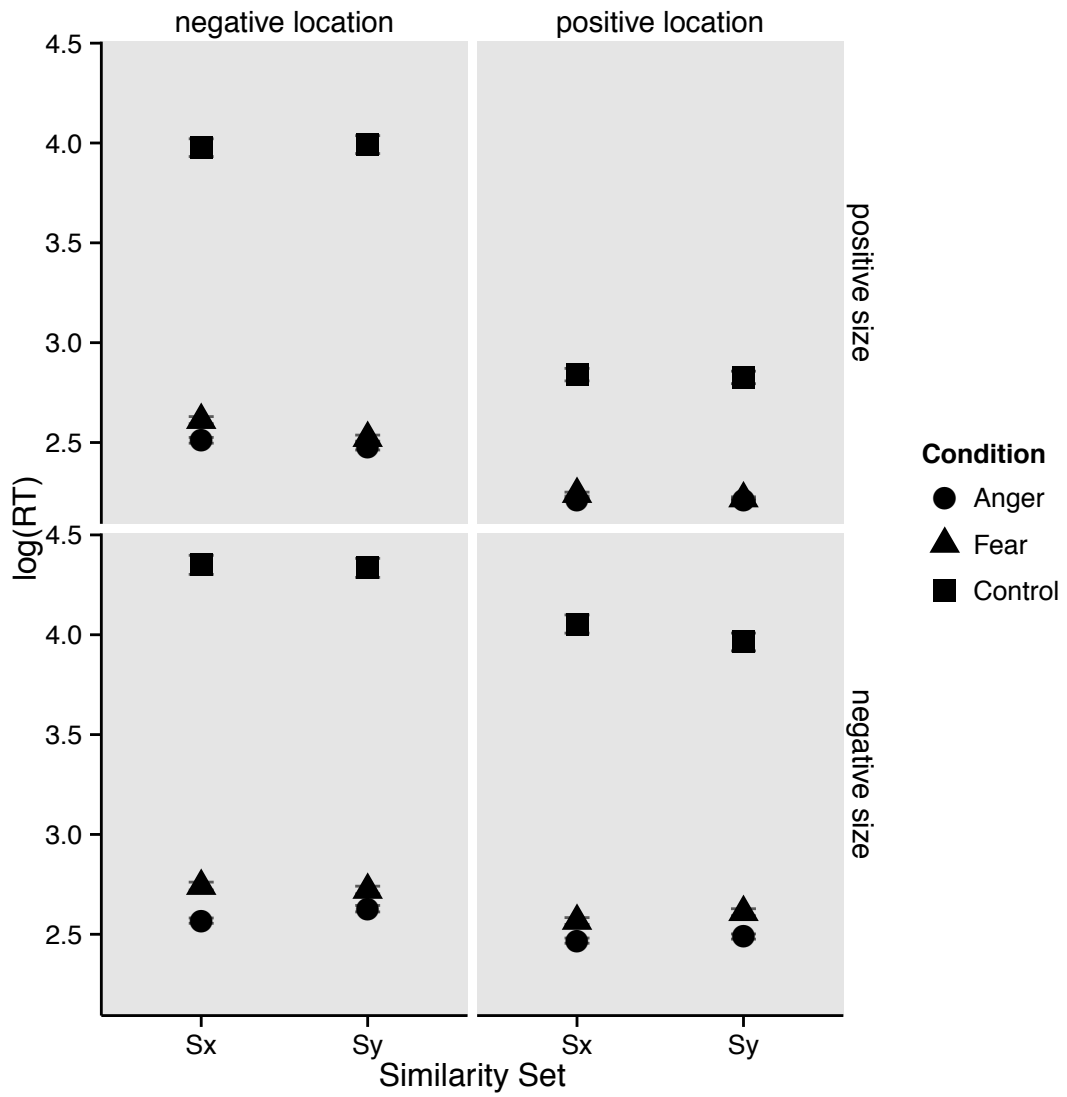

Figure 24: Differences in RT Between S Similarity Levels, Based on the Best-Fitting MLBA Parameter Values

APPENDIX A

MULTIALTERNATIVE DECISION FIELD THEORY

This appendix describes the implementation of the MDFT (Roe et al., 2001) and the specific parameter values used to simulate the similarity effect in both the three- and four-choice scenarios. Both cases assume an internally set threshold. The subscript “S_x” denotes the (X, Y, S_x) choice set and the subscript “S_y” denotes the (X, Y, S_y) choice set.

A.1 Three-Choice Scenario

The model begins with a matrix M that represents the ratings of each alternative, which were chosen based on the simulations conducted by Roe et al (2001):

$$M_{S_x} = \begin{bmatrix} 12.2 & 28.2 \\ 30.0 & 10.0 \\ 11.0 & 29.0 \end{bmatrix}$$

$$M_{S_y} = \begin{bmatrix} 12.2 & 28.2 \\ 30.0 & 10.0 \\ 30.8 & 8.8 \end{bmatrix}$$

The left-hand column represents ratings of each apartment’s size while the right-hand column represents ratings of each apartment’s location. The rows represent apartments X, Y, and S, from top to bottom.

The M matrix is multiplied by a weight vector W that determines the amount of attention each feature receives at a given point in time, t . The number of features determines the length of the vector. Attention is deployed to each feature in an all-

or-none fashion such that a feature is activated by a value of “1” and all other features are inhibited by a value of “0”. Therefore, W takes one of two forms in the present study:

$$W_S = [1 \quad 0]$$

$$W_L = [0 \quad 1]$$

Whether W_S or W_L is used on a given trial is determined probabilistically by w , whose value ranges from 0-1. A random number is generated on each pass through the model. If that number is less than w , W_S is used. Otherwise, W_L is used.

Multiplying the M matrix by W_S produces a matrix identical to M but with all location ratings set to 0, and multiplying the M matrix by W_L produces a matrix identical to M but with all size ratings set to 0. For the simulated Anger and Fear participants, w was set to .8 when size was framed negatively and location was framed positively; .2 when size was framed positively and location was framed negatively; and .5 when the two features were framed congruently. For the simulated Control participants, w was always set to .5.

The matrix product of M and W is then multiplied by a contrast matrix C , which serves to contrast the weighted value of one alternative against the average weighted values of n remaining alternatives:

$$C = \begin{bmatrix} 1 & -1/n & -1/n \\ -1/n & 1 & -1/n \\ -1/n & -1/n & 1 \end{bmatrix}$$

The valences of each alternative at time t is determined by the matrix product of the above operation plus error (SD=7):

$$V(t) = CMW(t) + \epsilon(t)$$

The preference strength of each alternative at time t is calculated by adding $V(t)$ to the product of the previous preference strength P (0 when $t=1$) and a feedback matrix S :

$$P(t + 1) = SP(t) + V(t + 1)$$

The matrix S serves to determine the degree of competition between alternatives via inter-connective feedback loops (off-diagonal values) and the degree of each alternative's own growth or decay over time via self-connective feedback loops (diagonal values):

$$S_{Sx} = \begin{bmatrix} .95 & -.003 & -.09 \\ -.003 & .95 & -.003 \\ -.09 & -.003 & .95 \end{bmatrix}$$

$$S_{Sy} = \begin{bmatrix} .95 & -.003 & -.003 \\ -.003 & .95 & -.09 \\ -.003 & -.09 & .95 \end{bmatrix}$$

Negative values in the matrix represent inhibition while positive values represent activation. Thus, self-connections facilitate growth of a given alternative's preference strength while inter-connections facilitate decay. Alternatives whose ratings are more similar to one another are more negative to produce increased competition.

An alternative was chosen once its preference strength P exceeded the predetermined threshold value. Reaction time was defined as the number of iterations of the model necessary for at least one alternative to exceed the threshold. The threshold value was set to 40 for the simulated Anger participants, 60 for the simulated Control participants, and 80 for the simulated Fear participants. Ten thousand synthetic subjects were run through the model.

A.2 Four-Choice Scenario

The similarity effect was simulated in a four-choice scenario assuming the same process as in the three-choice scenario, but with modified parameter values to reflect the expanded choice set. Only the modifications are described below.

Ratings for the fourth option C were added to the M matrix. Recall that four versions of C were used in this study: C_{++} , C_{+-} , C_{-+} , and C_{--} (see Figure 2). Therefore, the values of the fourth row in M depended on which version of C was used in a given trial:

$$M_{C_{++}} = [9.8 \quad 8.4]$$

$$M_{C_{+-}} = [9.8 \quad 29.8]$$

$$M_{C-+} = [31.6 \quad 8.4]$$

$$M_{C--} = [31.6 \quad 29.8]$$

A fourth row and column were added to the S matrix to include values representing the C self- and inter-connections. The inter-connections were estimated to be relatively small under the assumption that apartment C would be unlikely to compete strongly with other alternatives since it was not actually a viable option. Specifically, the values of C's interconnections were either .0005 or .001 depending on how similar C was to each alternative in a given choice set:

$$S_{S_{xC++|--}} = \begin{bmatrix} .95 & -.003 & -.09 & -.0005 \\ -.003 & .95 & -.003 & -.0005 \\ -.09 & -.003 & .95 & -.0005 \\ -.0005 & -.0005 & -.0005 & .95 \end{bmatrix}$$

$$S_{S_{yC++|--}} = \begin{bmatrix} .95 & -.003 & -.003 & -.0005 \\ -.003 & .95 & -.09 & -.0005 \\ -.003 & -.09 & .95 & -.0005 \\ -.0005 & -.0005 & -.0005 & .95 \end{bmatrix}$$

$$S_{S_{xC+-}} = \begin{bmatrix} .95 & -.003 & -.09 & -.0005 \\ -.003 & .95 & -.003 & -.001 \\ -.09 & -.003 & .95 & -.0005 \\ -.0005 & -.001 & -.0005 & .95 \end{bmatrix}$$

$$S_{S_{yC+-}} = \begin{bmatrix} .95 & -.003 & -.003 & -.0005 \\ -.003 & .95 & -.09 & -.001 \\ -.003 & -.09 & .95 & -.001 \\ -.0005 & -.001 & -.001 & .95 \end{bmatrix}$$

$$S_{S_{xC-+}} = \begin{bmatrix} .95 & -.003 & -.09 & -.001 \\ -.003 & .95 & -.003 & -.0005 \\ -.09 & -.003 & .95 & -.001 \\ -.001 & -.0005 & -.001 & .95 \end{bmatrix}$$

$$S_{Syc-+} = \begin{bmatrix} .95 & -.003 & -.003 & -.001 \\ -.003 & .95 & -.09 & -.0005 \\ -.003 & -.09 & .95 & -.0005 \\ -.001 & -.0005 & -.0005 & .95 \end{bmatrix}$$

As before, an alternative was chosen once its preference strength P exceeded the predetermined threshold value. However, only the preference strengths of alternatives X, Y, and S were evaluated, and C could therefore never be selected.

APPENDIX B

THE MULTIATTRIBUTE LINEAR BALLISTIC ACCUMULATOR

This appendix describes the implementation of the MLBA (Trueblood et al., 2014) and the specific parameter values used to simulate the similarity effect in both the three- and four-choice scenarios. Both cases assume an internally set threshold. The subscript “ S_x ” denotes the (X, Y, S_x) choice set and the subscript “ S_y ” denotes the (X, Y, S_y) choice set.

B.1 Three-Choice Scenario

The model begins by transforming the raw rating values into subjective rating values, u . The subjective mapping is premised on the assumption that when two alternatives have the same average value the alternative whose individual feature ratings are most similar is to be preferred. For example, consider the apartments X and S_x : apartment X has a rating of 2 for size and 3 for location and apartment S_x has a rating of 1.75 for size and 3.25 for location, resulting in an average rating of 2.5 for both. However, the ratings for apartment S_x are more “dispersed”; that is, the difference between the ratings for apartment S_x along size and location ($3.25 - 1.75 = 1.5$) is greater than the difference in the same ratings for apartment X ($3 - 2 = 1$). Therefore, apartment X is to be preferred. The subjective mapping is governed by the parameter m such that if $m > 1$ options with less dispersion are preferred (see Figure B1) and if $1 > m > 0$ options with greater dispersion are preferred. If $m = 1$, the subjective rating values are equal to the raw rating values. For simplicity we have adopted the assumption that no subjective

mapping of this quality occurs in the present paradigm, and have set $m = 1$ in all simulations and model fits. The values of u are therefore equal to the raw rating values, which were chosen based on the simulations conducted by Trueblood et al (2014):

$$u_{Sx} = \begin{bmatrix} 2 & 3 \\ 3 & 2 \\ 1.75 & 3.25 \end{bmatrix}$$

$$u_{Sy} = \begin{bmatrix} 2 & 3 \\ 3 & 2 \\ 3.25 & 1.75 \end{bmatrix}$$

The left-hand column represents ratings of each apartment's size while the right-hand column represents ratings of each apartment's location. The rows represent apartments X, Y, and S, from top to bottom.

The subjective rating values are then submitted to a valuation function V that calculates weighted contrasts of each alternative along each feature:

$$V_{ij} = w_{Sij} \cdot (u_{Si} - u_{Sj}) + w_{Lij} \cdot (u_{Li} - u_{Lj})$$

The values of V are governed by attention weights that are calculated separately for each feature. The attention weights are premised on the assumption that comparisons between alternatives with rating values that are very similar, and therefore more difficult to discriminate, will receive more attention than

comparisons between alternatives with dissimilar rating values. As such, attention weights are larger when u_i and u_j are similar and smaller when they are dissimilar:

$$w_{Sij} = \exp(-\lambda |u_{Si} - u_{Sj}|)$$

$$w_{Lij} = \exp(-\lambda |u_{Li} - u_{Lj}|)$$

The attention weights are themselves governed by λ , whose value depends on whether $u_i - u_j$ is positive or negative. If the difference is positive, $\lambda = \lambda_1$, and if the difference is negative, $\lambda = \lambda_2$. The MLBA claims that the similarity effect occurs when greater consideration is given to positive differences than to negative differences ($\lambda_1 < \lambda_2$). The authors posit that the necessity of this asymmetry may reflect a role of confirmation bias in the similarity effect, such that positive differences represent confirmatory evidence while negative difference represent dis-confirmatory evidence (Trueblood et al., 2014). In the present simulations and model fits $\lambda_1 = .2$ and $\lambda_2 = .4$, resulting in greater attention to positive differences after exponentiation.

The formula for V can be extended to include an additional parameter measuring attention for particular features, β . When the choice set includes only two features, the β parameter can take a single value that is multiplied by the contrast of just one of the features, such as location in the present study:

$$V_{ij} = w_{Sij} \cdot (u_{Si} - u_{Sj}) + w_{Lij} \cdot (u_{Li} - u_{Lj}) \cdot \beta_L$$

If $0 < \beta < 1$, less weight is placed on the contrast for location, reflecting decreased attention for location. If $1 < \beta$, greater weight is placed on the contrast for attention, reflecting increased attention for location.

The present study extended β to represent attention for location relative to size (β_L) as well as attention for negatively framed features relative to positively-framed features (β_N). Both β parameters were combined into one summary importance weight for each feature, γ :

$$\gamma_{S+} = 1$$

$$\gamma_{S-} = \beta_N$$

$$\gamma_{L+} = \beta_L$$

$$\gamma_{L-} = \beta_L \cdot \beta_N$$

The β_S parameter was set to 1 for all conditions. For simulations of Control participants, the β_N parameter was also set to 1 because Control participants were not expected to exhibit changes in attention for negatively framed features. For simulations of Anger and Fear participants, β_N was set to 2 to simulate an increase in attention for negatively framed features. The values of V were then calculated as follows:

$$V_{ij} = w_{Sij} \cdot (u_{Si} - u_{Sj}) \cdot \gamma_S + w_{Lij} \cdot (u_{Li} - u_{Lj}) \cdot \gamma_L$$

The rate at which the preference strength approaches the decision threshold is determined by the mean drift rate d_i , which is the sum of all V_{ij} and a positive constant I_0 :

$$d_X = V_{XY} + V_{XS} + I_0$$

$$d_Y = V_{YX} + V_{YS} + I_0$$

$$d_S = V_{SX} + V_{SY} + I_0$$

The drift rate for a given alternative on a particular trial is randomly sampled from $N(d_i, s)$, in which $s = 1$ for all alternatives.

The preference strength of each alternative begins at a value randomly sampled from a uniform distribution between 0 and A , which was fixed at 1 in both the simulations and model fits. The preference strength then grows or decays linearly at a rate of $d_i(t)$ until at least one alternative exceeds the predetermined threshold value X . Given the linear relationship between time and preference strength, we defined the preferred alternative in a given trial as the alternative associated with the minimum of all values $[X - A_i(t)] / d_i(t)$, and the value itself was recorded as the reaction time for that trial. The threshold value was set to 40 for the simulated Anger participants, 60 for the simulated Control participants, and 80 for the simulated Fear participants. Ten thousand synthetic subjects were run through the model.

B.2 Four-Choice Scenario

The similarity effect was simulated in a four-choice scenario assuming the same process as in the three-choice scenario, but with modified parameter values to reflect the expanded choice set. Only the modifications are described below.

Ratings for the fourth option C were added to the u matrix. Recall that four versions of C were used in this study: C_{++} , C_{+-} , C_{-+} , and C_{--} (see Figure 2). Therefore, the values of the fourth row in M depended on which version of C was used in a given trial:

$$u_{C_{++}} = [1.5 \quad 1.5]$$

$$u_{C_{+-}} = [1.5 \quad 3.5]$$

$$u_{C_{-+}} = [3.5 \quad 1.5]$$

$$u_{C_{--}} = [3.5 \quad 3.5]$$

As before, an alternative was chosen once its preference strength P exceeded the predetermined threshold value. However, only the preference strengths of alternatives X, Y, and S were evaluated, and C could therefore never be selected.

B.3 Model Fitting

Because the four-choice simulations more closely approximated subject data than did the three-choice simulations, model fitting was done using the four-choice version of the MLBA. The subjects' response time distributions were fit to the likelihood function recommended in the seminal LBA paper (Brown & Heathcote,

2008; eq. 1-3). The model was fit to aggregate data for each condition rather than to individual subjects due to the low within-subjects sample size. However, we attempted to account for subject variability by first scaling subject response times within each condition before fitting the model. Scaling was done by first computing the z score for each individual subject, then multiplying the z-score by the average standard deviation for the subject's particular condition and finally adding the mean response time for that condition.

The performance of the model is measured by the maximum log likelihood. The parameters A , s , and m were all fixed at 1, as suggested in Trueblood et al (2014).

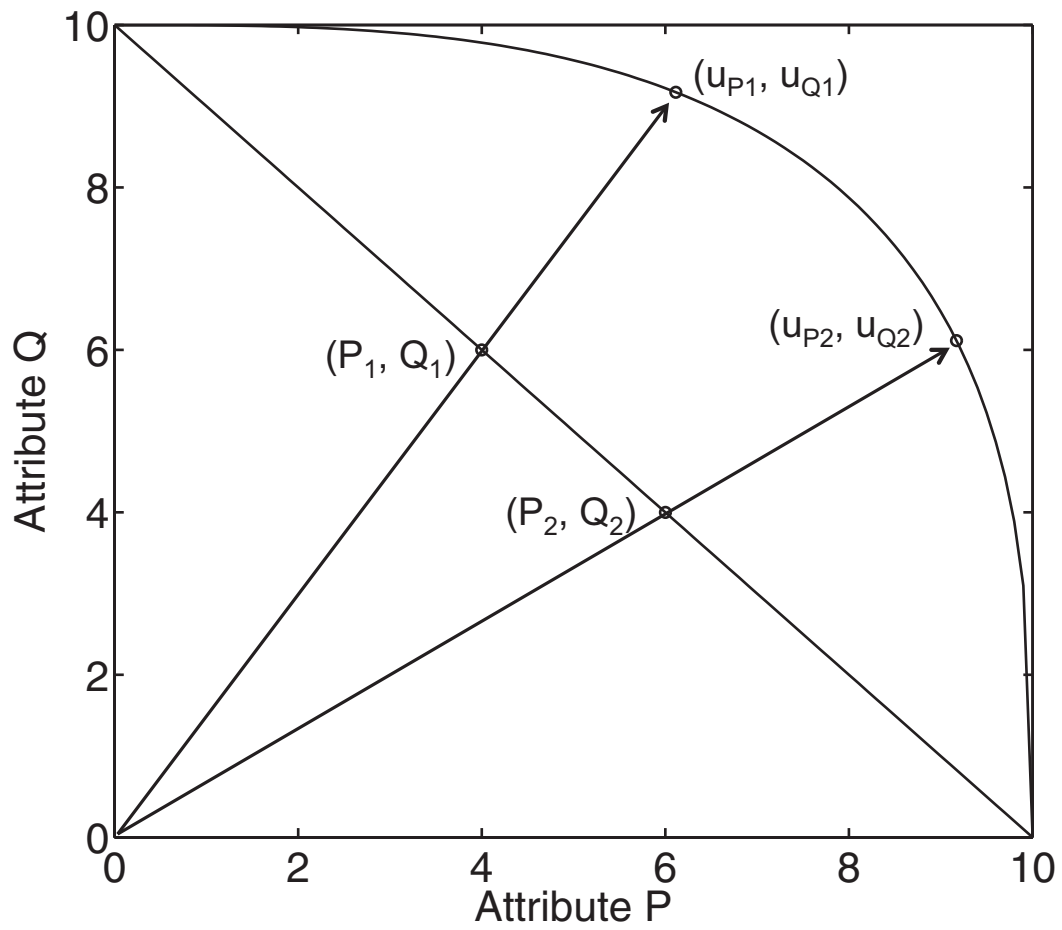

Figure B1: Example of Subjective Mapping of Raw Rating Values in the MLBA

Reproduced from Trueblood, Brown, & Heathcote (2014).

APPENDIX C

VIDEO PRETESTING

C.1 Method

C.1.1 Participants

A total of 519 participants (226 in the Anger condition; 223 in the Fear condition) were recruited on Amazon's Mechanical Turk (MTurk; Buhrmester et al., 2011). Of those participants 49 were excluded for not watching the video in full and 21 were excluded for technical difficulties leaving a total of 449 participants included in analyses. Participants were compensated \$0.10 for their time.

C.1.2 Materials

Twelve total videos were tested, with six videos tested for use in each of the Anger and Fear emotion conditions from the main experiment. These emotional states were expected to allow us to assess behavioral differences across the two emotion components of interest, valence and certainty. Anger is associated with negative valence and high certainty, while Fear is associated with negative valence and low certainty (Tiedens & Linton, 2001).

The videos were selected from a previously published stimuli set (Schaefer et al., 2010). The videos that were tested for the Anger category include a scene depicting a police interrogation from *In the Name of the Father* (3:30; N=31); two scenes from *Schindler's List*: one depicting a concentration camp officer shooting prisoners (a; 1:55; N=41) and a second depicting Jews being killed in a WWII ghetto

(b; 1:18; N=32); a scene from *Life is Beautiful* (2:07; N=43) in which a father is killed to save his son; a scene from *Seven* (5:52; N=43) in which one character tells another that he has beheaded his pregnant wife; and a scene from *A Perfect World* (4:27; N=36) in which a man is gunned down in front of the child he has befriended. The videos that were tested for the Fear category include a scene from *Scream* (6:33; N=27) in which a girl is threatened by the killer over the phone; a scene from *The Shining* (4:15; N=34) in which a man pursues his wife with an axe; a scene from *Blair Witch Project* (3:57; N=45) in which the characters arrive at an ominous cabin in the woods; a scene from *Scream 2* (3:35; N=33) in which one character sees another being attacked by the killer through a one-way mirror; a scene from *Child's Play 2* (1:05; N=41) in which Chucky beats a teacher with a ruler; and a scene from *Copycat* (2:23; N=43) in which a detective is caught and attacked by the killer she is investigating.

As in the original publication, the present study included the Positive and Negative Affect Schedule (PANAS; Watson et al., 1988) as a measure of valence and the Differential Emotions Scale (DES; Boyle, 1984) as a measure of several discrete emotional states (see Appendix I and D, respectively). Physiological arousal was measured using the same seven-point Likert scale used in the previous study, plus an additional item (see Appendix F). Additionally, the present study included four seven-point Likert scale items to measure certainty (see Appendix E).

C.1.3 Procedure

Participants were randomly assigned to watch one of the 12 videos. After watching the video, participants completed the PANAS and DES, followed by the five Likert scale items measuring physiological arousal and certainty and a brief demographics questionnaire (see Appendix H). The experiment finished with the reinstatement of a positive mood by having participants view a scene from *Benny and Joon* (2:06) including physical comedy.

C.2 Results

The purpose of the video pretesting was to determine the videos that performed best in an absolute sense across measures of discrete emotion, positive and negative valence, arousal, and certainty. Therefore no inferential tests were performed and only descriptive statistics follow.

Participants' responses to the DES are summarized in Figure C1. The DES consists of 43 items that each measure a particular emotional state. The emotions listed in the DES were collapsed into 16 aggregate groups measuring more general emotional states, which noted along the x -axis of Figure C1. Among the 16 aggregate groups were the three emotions to be targeted in the main experiment: Anger, Fear, and Calmness (an approximate measure of neutrality). The aggregate groups were formed by performing a reliability analysis (DeSteno, Dasgupta, Bartlett, & Cajdric, 2004) to determine which emotional states were likely to be reported similarly. In particular, we calculated Cronbach's alpha, which is a measure of the internal consistency of a psychometric test and, in this case, determines how well the rated emotions covary or group together

(Cronbach, 1951). Higher scores indicate better grouping. Cronbach's alpha ranges from 0 to 1 and a cutoff of .70 is often applied (Nunnally, 1978). We adopt that practice here. The aggregate groups were created as follows: angry, irritated, and mad formed the angry group ($\alpha=0.893$); fearful, scared, and afraid formed the fear group ($\alpha=0.956$); calm, serene, and relaxed formed the calm group ($\alpha=0.852$). The non-target aggregate groups are detailed in Table C1.

Figure C1 presents the mean subscale scores for each video. Ideal videos would have subscale scores that are high for the target emotion and low elsewhere. Among the Anger videos, *Schindler's List (a)* was rated the higher in the Anger subscale of the DES than any other video. It was also rated higher in the Anger subscale than in any other subscale targeted in the main experiment; that is, it rated higher for Anger than for Fear or Calmness (used here as an approximate measure of a neutral emotion). However, it should be noted that it was rated highly for several non-target subscales, particularly interest, sadness, and disgust. As other Anger videos also rated highly in these non-target subscales, *Schindler's List (a)* was still determined to perform best in the DES for Anger.

Among the Fear videos, *Blair Witch Project* was rated higher in the Fear subscale of the DES than any other video. It was also rated higher in the Fear subscale than in any other subscale targeted in the main experiment; that is, it rated higher for Fear than for Anger or Calmness. It also rated highly for two non-target subscales: interest and anxiety. As this was again also the case for other Fear videos, *Blair Witch Project* was still determined to perform best in the DES for Fear.

The hypotheses of the main experiment rest on the assumptions that Anger is a negative emotion characterized by certainty and Fear is a negative emotion characterized by uncertainty. Given that multiple emotions were endorsed on the DES for each video it is therefore important to investigate their performance in measures of valence and certainty. Participants' responses to the valence subscales in the PANAS are summarized in Figure C2. The PANAS consists of a positive and negative subscale each consisting of 10 word items related to the target valence, which are then averaged to create a summary score for that subscale. Cronbach's alpha was above the .70 cutoff for both subscales (positive affect: $\alpha=0.796$; negative affect: $\alpha=0.848$). The top panel of Figure C2 presents the mean subscale scores for each video. In both the Anger and Fear conditions, ideal videos would have subscale scores that are high in negative affect and low in positive affect. While the Anger videos generally rated high in the negative subscale and low in the positive subscale, the opposite was true for the Fear videos (with the exception of *Blair Witch Project*, which was rated in the appropriate direction). The videos which performed best on the DES also performed highly on the PANAS compared to other videos with the same target emotion: *Schindler's List (a)* and *Blair Witch Project* rated higher in the negative subscale than in the positive scale, which in both cases were the largest such differences among the videos in their respective target emotions (see Figure C2, bottom panel).

As noted by the authors of the original video database (Schaefer et al., 2010), the PANAS may not be a thorough measure of positive and negative emotional valence given its inclusion of valence-nonspecific word items as "interested",

“strong”, and “alert” in the positive subscale. We therefore followed their suggestion of creating positive and negative subscales using items from the DES (included items marked in Appendix D). These subscales did have higher Cronbach’s alpha values than the PANAS subscales (positive affect: $\alpha=0.845$; negative affect: $\alpha=0.936$). Participants’ responses to these subscales are summarized in the top panel of Figure C3. The positive and negative DES subscales were more highly distinguished in each video than were the PANAS subscales, with the negative subscale receiving higher ratings than the positive subscale in almost all cases. *Schindler’s List (a)* and *Blair Witch Project* again had the greatest differences between the two scales among the videos in their respective target emotions (see Figure C3, bottom panel).

The ratings for certainty are presented in Figure C4. The four certainty items that were administered were each rated on a 1-7 scale. All ranged from high certainty to high uncertainty, therefore an ideal video for Anger would have a low average score while an ideal video for Fear would have a high average score. Participant ratings were averaged across the four items, and the distributions of these average scores are presented in Figure 10. Among the Anger videos, *Seven* performed best in this regard with the lowest average score (median = 1, mode = 1). However, *Schindler’s List (a)* also performed well (median = 2, mode = 2). Among the Fear videos, *Blair Witch Project* performed best (median = 5, mode = 5).

The ratings for arousal are presented in Figure C5. The two arousal items that were administered were each rated on a 1-7 scale. The first item ranged from low to high arousal while the second ranged from high to low arousal (see Appendix F). The second item was reverse-scored, and participant ratings were then averaged

across both items. The distributions presented in Figure C5 are of these average scores. Ideal videos for Anger and Fear would elicit comparable arousal, as arousal is not an emotion component of focus for this study. Both *Schindler's List (a)* and *Blair Witch Project* have comparably moderate median and modal ratings.

Table C1: Non-target Aggregate Groups in the DES: Video Pretesting

Group	Items	Cronbach's Alpha
Interested	Interested	.88
	Concentrated	
	Alert	
Anxious	Anxious	.92
	Tense	
	Nervous	
Ashamed	Ashamed	.82
	Embarrassed	
Gleeful	Warm-Hearted	.61
	Gleeful	
	Elated	
Happy	Joyful	.78
	Amused	
	Happy	
Sad	Sad	.93
	Down-Hearted	
	Blue	
Satisfied	Satisfied	.89
	Pleased	
Surprised	Surprised	.80
	Amazed	
	Astonished	
Loving	Loving	.87
	Affectionate	
	Friendly	
Guilty	Guilty	.65
	Remorseful	
Disgusted	Disgusted	.85
	Turned-Off	
	Repulsed	
Disdainful	Disdainful	.92
	Scornful	
	Contemptuous	

All Videos: DES Mean Ratings

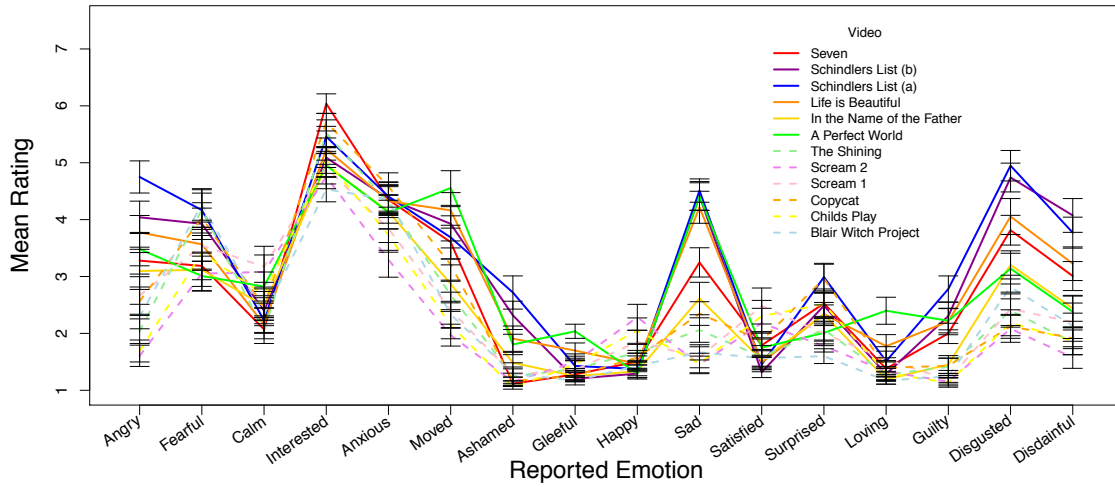

Best Video per Emotion: DES Mean Ratings

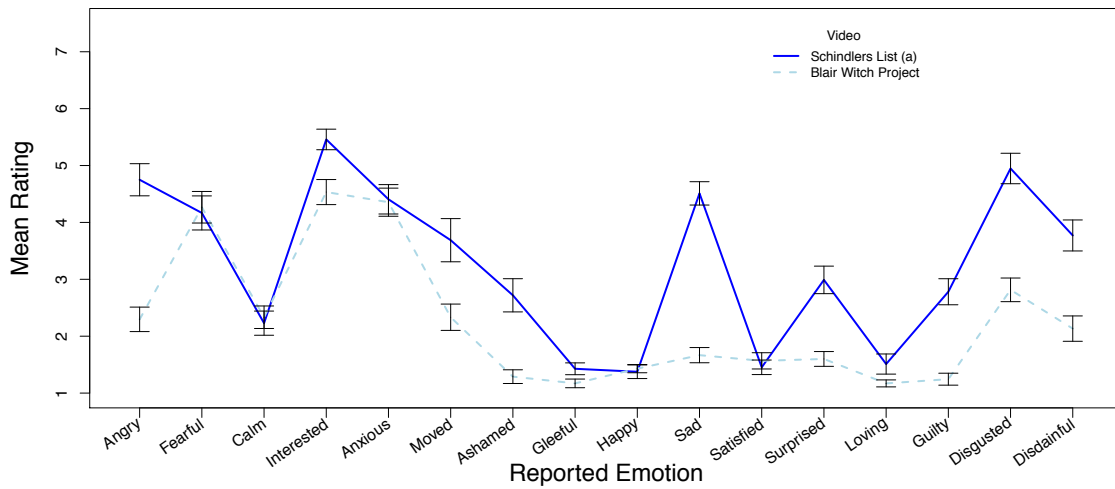
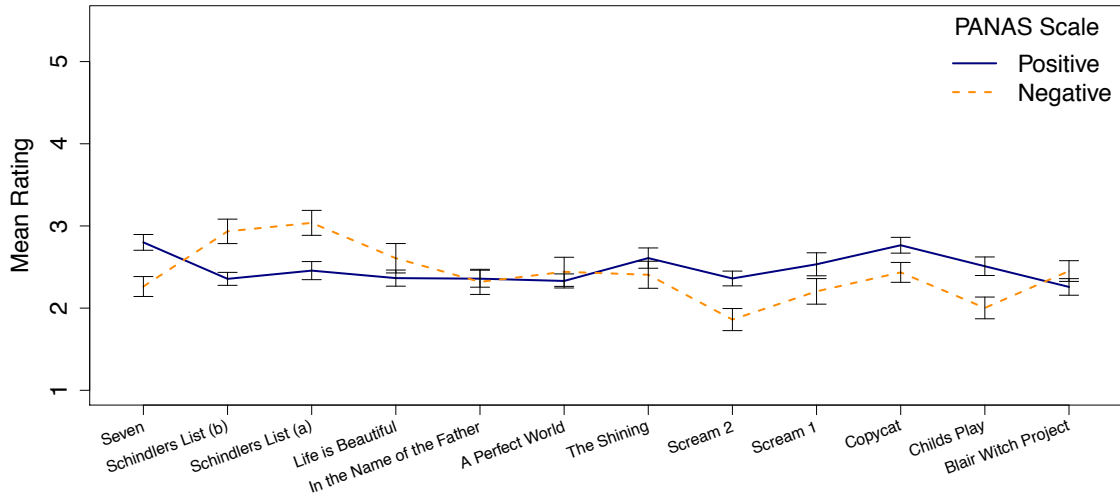

Figure C1: Average DES Ratings (Video Pretesting)

All Videos: PANAS Mean Ratings



Best Video per Emotion: PANAS Mean Ratings

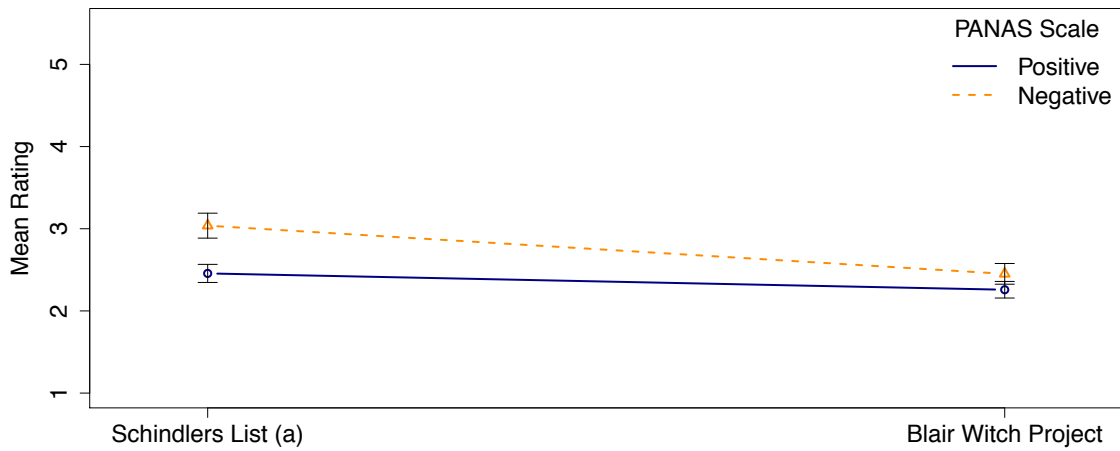
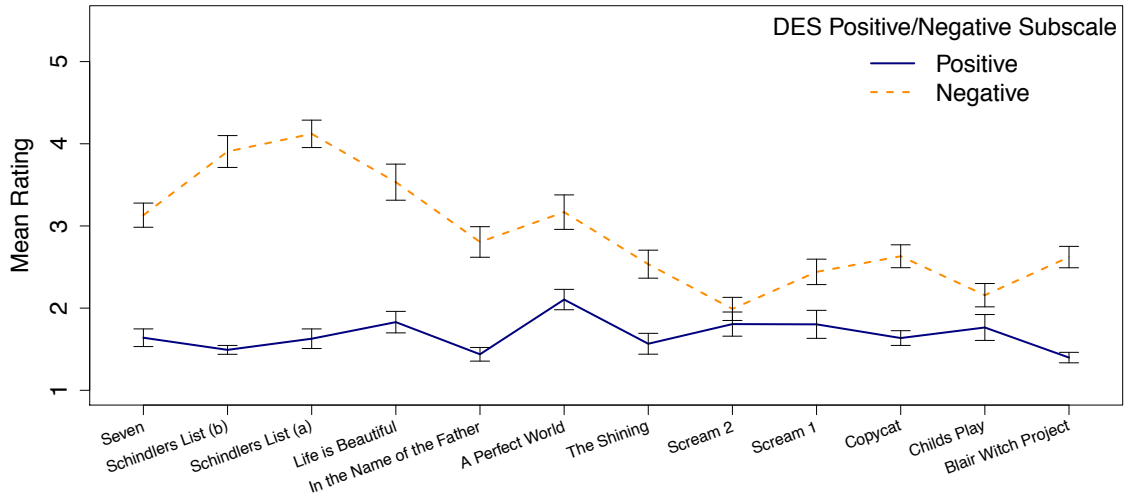

Figure C2: Average PANAS Ratings (Video Pretesting)

All Videos: DES Positive/Negative Subscale Mean Ratings



Best Video per Emotion: DES Positive/Negative Subscale Mean Ratings

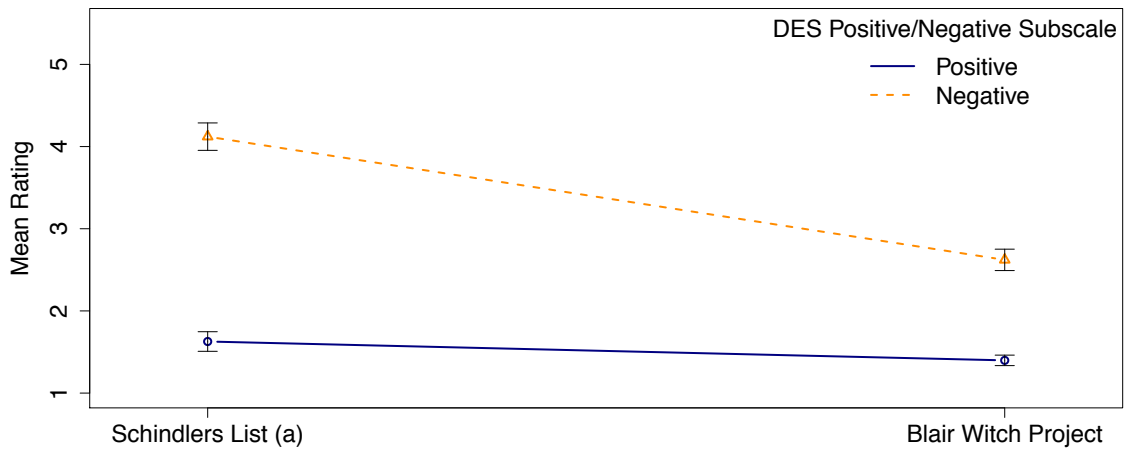

Figure C3: Average DES Positive/Negative Subscale Ratings (Video Pretesting)

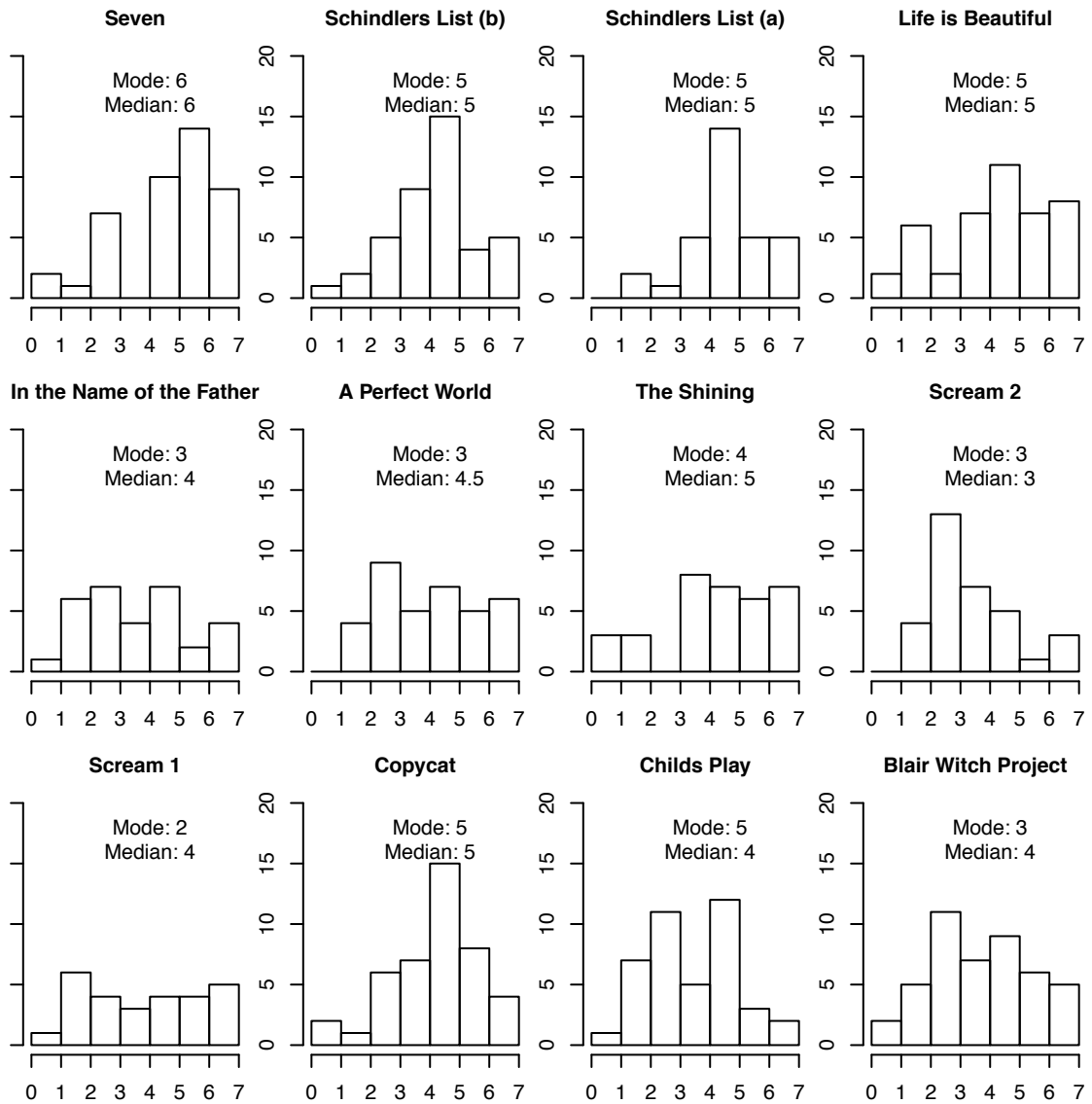

Figure C4: Distributions of Responses to the Arousal Items (Video Pretesting)

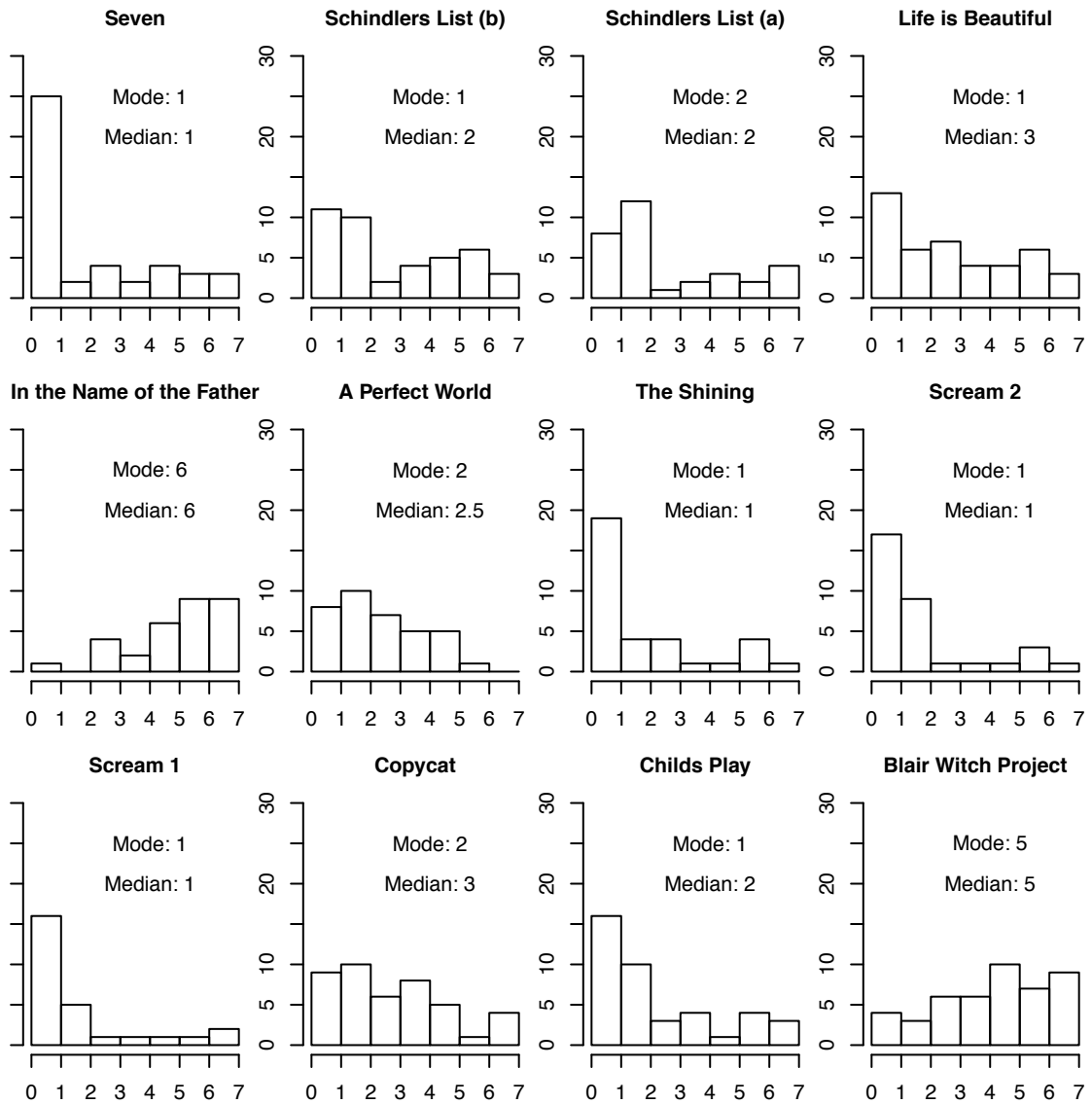

Figure C5: Distributions of Responses to the Certainty Items (Video Pretesting)

APPENDIX D

DIFFERENTIAL EMOTIONS SCALE

For each item, please rate the extent to which you felt each state while you were watching the video:

[PARTICIPANTS WERE PROVIDED WITH A 1-7 SCALE ON QUALTRICS RANGING FROM “NOT AT ALL” TO “VERY INTENSE”]

* Item was included in the main experiment.

^P Item was included in positive subscale.

^N Item was included in negative subscale.

- | | |
|---------------------------------|---------------------------------|
| 1. interested | 23. down-hearted * ^N |
| 2. concentrated | 24. blue * ^N |
| 3. alert | 25. satisfied ^P |
| 4. fearful * ^N | 26. pleased ^P |
| 5. scared * ^N | 27. surprised * |
| 6. afraid * ^N | 28. amazed * |
| 7. anxious * ^N | 29. astonished * |
| 8. tense * ^N | 30. loving ^P |
| 9. nervous * ^N | 31. affectionate ^P |
| 10. moved ^P | 32. friendly ^P |
| 11. angry * ^N | 33. guilty ^N |
| 12. irritated * ^N | 34. remorseful ^N |
| 13. mad * ^N | 35. disgusted * ^N |
| 14. ashamed ^N | 36. turned-off * ^N |
| 15. embarrassed ^N | 37. repulsed * ^N |
| 16. warm-hearted * ^P | 38. disdainful * ^N |
| 17. gleeful * ^P | 39. scornful * ^N |
| 18. elated * ^P | 40. contemptuous * ^N |
| 19. joyful * ^P | 41. calm * |
| 20. amused * ^P | 42. serene * |
| 21. happy * ^P | 43. relaxed * |
| 22. sad * ^N | |

APPENDIX E

CERTAINTY SCALE ITEMS

[ANGER/FEAR]: While I was watching the video:

[CONTROL]: During the study:

1. I was very certain about what was happening (1)
...
I was very uncertain about what was happening (7)

2. I was very certain about the situation that was presented (1)
...
I was very uncertain about the situation that was presented (7)

3. I was very certain about what might happen next (1)
...
I was very uncertain about what might happen next (7)

4. I was very certain about my opinions (1)
...
I was very uncertain about my opinions (7)

APPENDIX F

AROUSAL SCALE ITEMS

[ANGER/FEAR]: While I was watching the video:

[CONTROL]: During the study:

1. I felt no emotions at all (1)

...

I felt very intense emotions (7)

2. I was very excited (1)

...

I was very calm (7) [ITEM WAS REVERSE CODED]

APPENDIX G

PREFERENTIAL CHOICE TASK INSTRUCTIONS

You are about to participate in two unrelated studies: one on movies and one on consumer choice.

In the first study, the movie study, you will be asked to view two short movie clips and then provide ratings regarding the quality of the clip and your personal experience viewing the clip. Different viewers are likely to have different reactions to the clips. We are interested in learning your reactions to the movie clips in order to construct better stimuli for a future study.

In the second study, the consumer choice study, you will be provided with information about different apartments. You will then be asked to select the apartment that you prefer most.

Your first task is to complete three practice consumer choice scenarios to measure your comprehension before beginning either study. Please click “continue” to proceed to the practice trials.

You are about to begin the **practice** trials for the consumer choice study. In each trial of this study, you will be asked to imagine that you are shopping for a new apartment. You will be shown ratings for three different apartments, and you will be asked to choose the option you most prefer based on those ratings.

To demonstrate, consider the following trial in which you are choosing a new apartment:

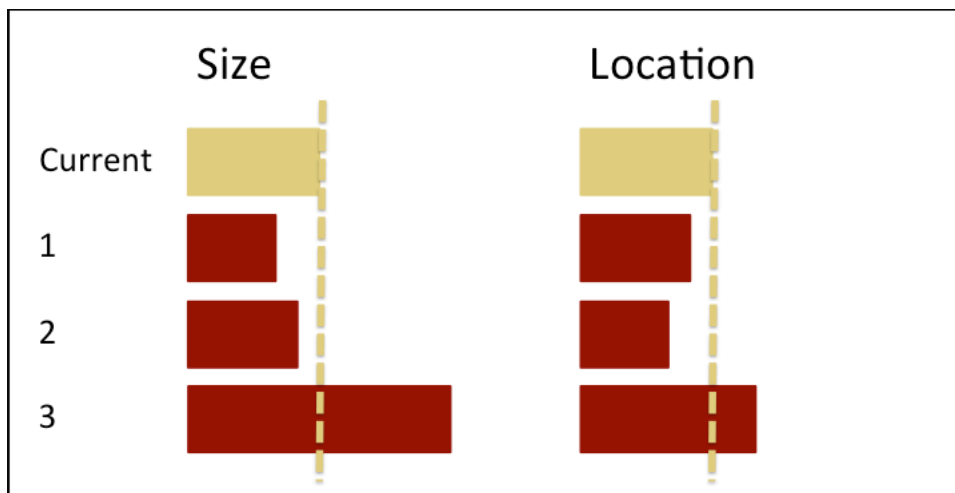

Each apartment has been rated on two features. The left-hand bars show the ratings for each apartment's size, and the right-hand bars show the ratings for each apartment's location.

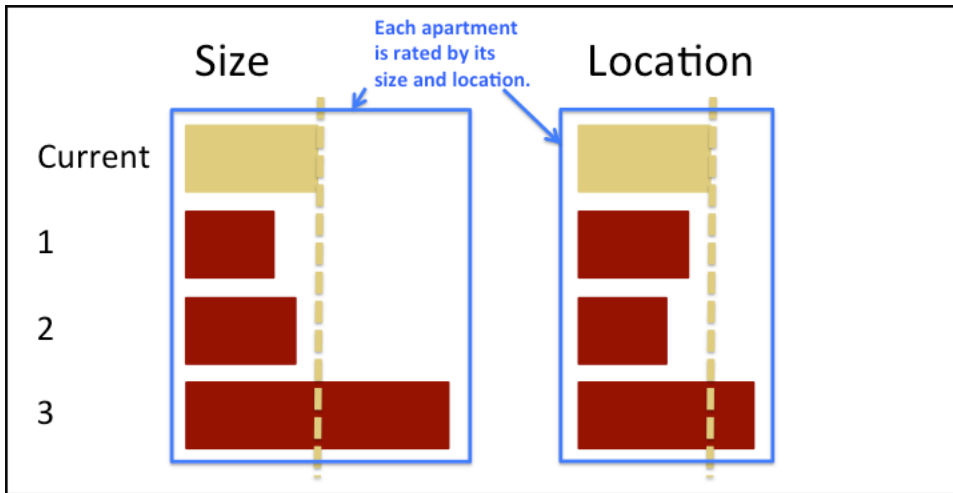

The ratings for the three new apartments are in red. Sometimes the ratings for your current apartment are also displayed for your reference, with a dashed line extending down across the rating bars for the new apartments so that you may compare them to your current apartment if you wish.

Note that sometimes the information for your current apartment won't be available, and you will only see information for the three new apartments. The task will still be exactly the same in this case, but you just won't be able to compare the new apartments to your current apartment.

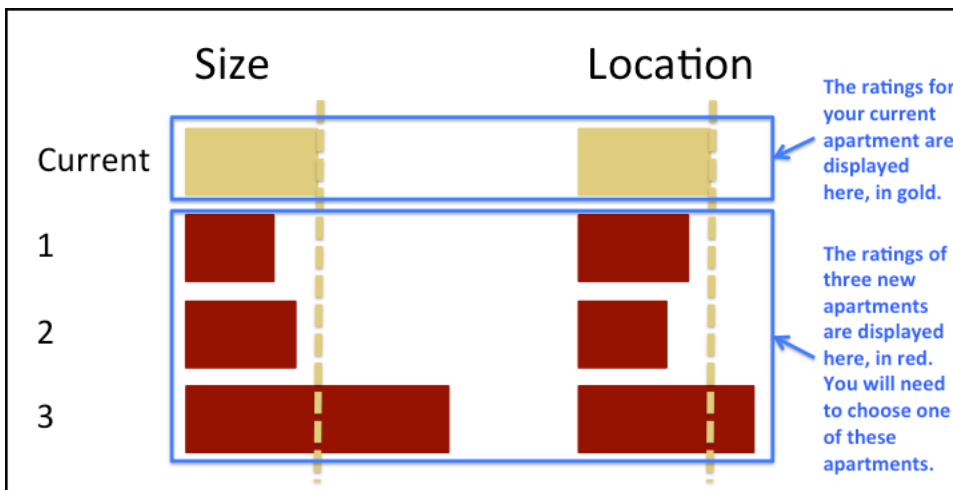

The longer the bar is, the better that apartment rates for you. The shorter the bar is, the worse that apartment rates for you. That is, a long bar under the Size feature doesn't necessarily mean that the apartment is larger or smaller, just that it is better

suiting for you personally. You will see that sometimes the new apartments are better suited for you than your current apartment within a particular feature, and sometimes they are worse.

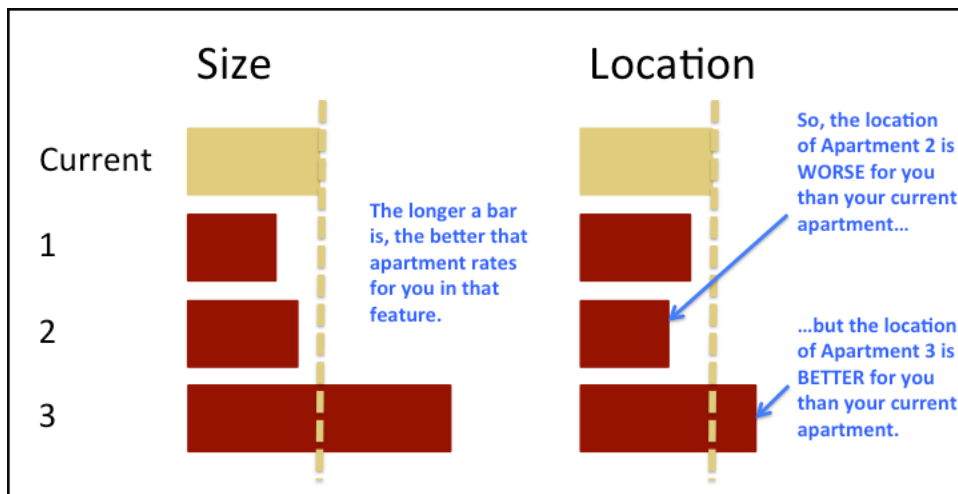

Now, consider the ratings for the apartments presented in this trial. Which of the new apartments do you most prefer? Once you have decided, select the button with the corresponding number below the image.

APPENDIX H

POST-EXPERIMENTAL QUESTIONNAIRE

All responses are kept confidential.

1. What is your age?
2. What is your gender?
3. What race or ethnicity do you most closely identify with?
 - _ White
 - _ African-American or Black
 - _ Hispanic or Latino
 - _ Asian or Pacific Islander
 - _ Other (please specify: _____)
4. Is English your first language? If not, for how long have you been speaking English?
5. Have you previously viewed the movie from which the clip was taken? If so, have you watched the movie in its entirety? Please explain. [ANGER AND FEAR ONLY]
6. As you were taking the experiment, what did you think that the movie-rating task was measuring? Please explain. [PREFERENTIAL CHOICE EXPERIMENT, ANGER AND FEAR ONLY]
7. As you were taking the experiment, what did you think the consumer choice task was measuring? [PREFERENTIAL CHOICE EXPERIMENT ONLY]
8. As you were taking the experiment, did you think that the two tasks (mentioned in Questions 6 & 7) were related in any way? Please explain. [PREFERENTIAL CHOICE EXPERIMENT, ANGER AND FEAR ONLY]
9. What do you think this experiment was about? Please explain.
10. Please think back to the first video you watched. Had you previously seen the movie from which the clip was taken? If yes, had you watched the movie in its entirety? Please explain. [ANGER AND FEAR ONLY]
11. In one or two sentences, please describe the gist of the first video that you watched. [ANGER AND FEAR ONLY]

12. Did you experience any technical difficulties with this experiment? If so, please explain.

APPENDIX I

POSITIVE AND NEGATIVE AFFECT SCHEDULE

This scale consists of a number of words that describe different feelings and emotions. Read each item and then list the number from the scale below next to each word. Indicate to what extent you feel this way right now; that is, at the present moment.

1	2	3	4	5
Very Slightly or Not at All	A Little	Moderately	Quite a Bit	Extremely

_____ 1. Interested	_____ 11. Irritable
_____ 2. Distressed	_____ 12. Alert
_____ 3. Excited	_____ 13. Ashamed
_____ 4. Upset	_____ 14. Inspired
_____ 5. Strong	_____ 15. Nervous
_____ 6. Guilty	_____ 16. Determined
_____ 7. Scared	_____ 17. Attentive
_____ 8. Hostile	_____ 18. Jittery
_____ 9. Enthusiastic	_____ 19. Active
_____ 10. Proud	_____ 20. Afraid

REFERENCES

- Bechara, A., Damasio, A. R., Damasio, H., & Anderson, S. W. (1994). Insensitivity to future consequences following damage to human prefrontal cortex. *Cognition, 50*(1-3), 7–15.
- Bohner, G., & Weinerth, T. (2001). Negative affect can increase or decrease message scrutiny: The affect interpretation hypothesis. *Personality and Social Psychology Bulletin, 27*(11), 1417–1428.
- Bower, G. H. (1981). Mood and memory. *American Psychologist, 36*(2), 129–148.
- Boyle, G. J. (1984). Reliability and validity of Izard's Differential Emotions Scale. *Personality and Individual Differences, 5*(6), 747–750.
- Brown, S. D., & Heathcote, A. (2008). The simplest complete model of choice response time: Linear ballistic accumulation. *Cognitive Psychology, 57*(3), 153–178.
- Buhrmester, M., Kwang, T., & Gosling, S. D. (2011). Amazon's Mechanical Turk: A new source of inexpensive, yet high-quality, data? *Perspectives on Psychological Science, 6*(1), 3–5.
- Cronbach, L. J. (1951). Coefficient alpha and the internal structure of tests. *Psychometrika, 16*, 297–334.
- DeSteno, D., Dasgupta, N., Bartlett, M. Y., & Caidric, A. (2004). Prejudice from Thin Air: The effect of emotion on automatic intergroup attitudes. *Psychological Science, 15*(5), 319–324.
- Gross, J. J., & Levenson, R. W. (1995). Emotion elicitation using films. *Cognition and Emotion, 9*(1), 87–108.
- Johnson, E. J., & Tversky, A. (1983). Affect, generalization, and the perception of risk. *Journal of Personality and Social Psychology, 45*(1), 20–31.
- Lerner, J. S., & Keltner, D. (2000). Beyond valence: Toward a model of emotion-specific influences on judgement and choice. *Cognition and Emotion, 14*(4), 473–493.
- Martin, M., Williams, R. M., & Clark, D. M. (1991). Does anxiety lead to selective processing of threat-related information? *Behaviour Research and Therapy, 29*(2), 147–160.
- Nunnally, J. C. (1978). *Psychometric theory*. New York, NY, US: McGraw-Hill.

- Roe, R. M., Busemeyer, J. R., & Townsend, J. T. (2001). Multialternative decision field theory: A dynamic connectionist model of decision making. *Psychological Review*, *108*(2), 370–392.
- Schaefer, A., Nils, F., Sanchez, X., & Philippot, P. (2010). Assessing the effectiveness of a large database of emotion-eliciting films: A new tool for emotion researchers. *Cognition & Emotion*, *24*(7), 1153–1172.
- Schwarz, N. (2000). Emotion, cognition, and decision making. *Cognition and Emotion*, *14*(4), 433–440.
- So, J., Achar, C., Han, D., Agrawal, N., Duhachek, A., & Maheswaran, D. (2015). The psychology of appraisal: Specific emotions and decision-making. *Journal of Consumer Psychology*, *25*(3), 359–371.
- Strauss, G. P., & Allen, D. N. (2006). The experience of positive emotion is associated with the automatic processing of positive emotional words. *The Journal of Positive Psychology*, *1*(3), 150–159.
- Tiedens, L. Z., & Linton, S. (2001). Judgment under emotional certainty and uncertainty: The effects of specific emotions on information processing. *Journal of Personality and Social Psychology*, *81*(6), 973–988.
- Trueblood, J. S., Brown, S. D., & Heathcote, A. (2014). The multiattribute linear ballistic accumulator model of context effects in multialternative choice. *Psychological Review*, *121*(2), 179–205.
- Tversky, A. (1972). Elimination by aspects: A theory of choice. *Psychological Review*, *79*(4), 281–299.
- Watson, D., Clark, L. A., & Tellegen, A. (1988). Development and validation of brief measures of positive and negative affect: The PANAS scales. *Journal of Personality and Social Psychology*, *54*(6), 1063–1070.
- Wedell, D. H. (1991). Distinguishing among models of contextually induced preference reversals. *Journal of Experimental Psychology: Learning, Memory, and Cognition*, *17*(4), 767–778.