

Cal Poly Sustainable Power for Electrical Resources (SuPER) Microcontroller Integration

Eric Skinkis

Dr. Ali Shaban, Dr. Jim Harris

1. I agree to supervise this senior project. _____

2. The specifications are [1]-[2]:

- Implementation Free—Describes what project should do, not how.
- Bounded—Identify project boundaries, scope, and context
- Complete—Include all the requirements identified by the customer, as well as those needed to define the project.
- Unambiguous—Concisely state one clear meaning.
- Verifiable—A test can prove if system meets specification.
- Traceable—Each engineering specification serves at least one marketing requirement.

ADVISORS: Please initial above, if you agree to supervise this senior project. Also, please check applicable boxes above. Comment below, if requirements or specifications require revision.

**Cal Poly Sustainable Power for Electrical Resources
Microcontroller Integration**

by

Eric Skinkis

Senior Project

ELECTRICAL ENGINEERING DEPARTMENT

California Polytechnic State University

San Luis Obispo

2016

Table of Contents

Abstract	5
Chapter 1: Introduction	6
Chapter 2:	6
1. Customer needs	
2. Requirements and Specifications	
Chapter 3: Functional Decomposition	8
Chapter 4: Project Planning	12
Chapter 5: I2C	14
1. Background	
2. Implementation	
Chapter 6: Sensors	15
1. Voltage	
2. Current	
Chapter 7: SPI and RTCC for SD card Data Logging	17
1. Background	
2. Implementation	
Chapter 8: USB	18
1. Background	
2. Implementation	
Chapter 9: System Testing and Results	19
1. Integration testing	
2. Results	
Chapter 10: Conclusions and Recommendations for the Future	19
References	21
Appendices	22
1. Development lessons learned	
A. Updated Versions	
B. I2C	
C. SPI	
D. RTCC	
E. USB	
F. PIC24F Family	
2. Code	
3. ABET Senior Project Analysis	

Tables

Table 1: Cal Poly Super Microcontroller Integration Requirements and Specifications	7
Table 2: Level 0 Block Diagram Functions	9
Table 3: Level 1 Block Diagram Functions	10
Table 4: Costs Estimate	13
Table 5: Cal Poly Super Microcontroller Integration Deliverables	13
Table 6: Voltage Sensor Readings	16

Figures

Figure 1: Level 0 Block Diagram	8
Figure 2: Level 1 Block Diagram	10
Figure 3: Gantt Chart	12
Figure 4: I2C Hardware Connection	15
Figure 5: Master Read Software Flow	15
Figure 6: Voltage Sensor Circuit	16
Figure 7: Current Sensor Circuit	17
Figure 8: SD Card Pin Diagram	18

Abstract

This project further develops the Sustainable Power for Electrical Resources (SuPER) system introduced by Dr. Jim Harris. The SuPER system produces modest electricity generation capabilities providing families with no alternative electric grid access to a reliable source. Previous versions of the SuPER system was controlled and monitored by a laptop. The system is being redesigned to be controlled by microcontrollers in order to reduce unnecessary power consumption and simplify sensor integration. This transition was started by Clifford Susa and Emmanuel Solorio and this project seeks to recreate and expand upon the abilities of their system. Two versions of boards are used, a controller board responsible for analyzing, storing, and reacting to data, and a digitizer board that handles data collection. At the end of this project the ability to communicate between the boards using I2C and logging data paired with a timestamp on a SD card have been developed but were unable to be integrating into a full system.

Chapter 1: Introduction

The microcontroller integration project modifies the existing SuPER platform by replacing the laptop system. Using a laptop is a costly and power-hungry means of controlling the system. Implementing microcontrollers to analyze the device's operation brings down the cost of the system and frees more power for loads.

SuPER is targeted towards developing regions of the world that have no access to electricity, which the International Energy Agency estimates to include 1.3 billion people. Access to electricity is a convenience taken for granted by nearly all those in developed countries; access to electricity enables the largest quality of life impact. The SuPER system seeks to provide modest electrical generation and storage capabilities to the 1.3 billion without power. Capable of providing LED lighting, laptop and cellphone charging, small scale refrigeration, or any other relatively low power electrical device, a SuPER system has the ability to drastically improve life for its operators.

This project continues the work of numerous senior projects and master's theses; however it expands mostly on the work by Clifford Susa [3] and Emmanuel Solorio [4] who developed an initial prototype of the controller and digitizer boards that replace the laptop. This project and report are also an extension of work completed in summer 2015 where I and a team of Brazilian exchange students extensively researched the development of the SuPER system and started work on expanding the microcontroller capabilities [16] [17] [18]. The goals of the project are to finish the initial microcontroller development and implement the boards into the system to create a fully functioning SuPER system.

SuPER's final goal is to increase the standard of living for as many people as is possible. Doing this requires minimizing the product cost. Estimations from Dr. Harris' proposal place the target system purchase price at \$500 [11]. This is likely greater than what the target customers can afford without bank support, and banks are unlikely to provide such high risk and low return loans, leaving non-profits and aid programs as the buyer. Marketing towards aid programs and non-profits increases SuPER's impact by greatly increasing the rate that the system can be distributed since these programs already have distribution lines to the impacted areas.

My motivation for working on this project stems from an interest in microcontrollers as well as renewable resources including solar power. These interests make the SuPER project an ideal learning experience.

Chapter 2: Customer Needs, Requirements and Specifications

Customer Needs Assessment

The end customers are people living without access to an electrical grid, most commonly found in third world and developing countries. The SuPER system offers modest electrical generation capabilities allowing loads such as lights, cellphone/laptop charging, small scale refrigeration, and limited motor use. These loads are prioritized as they create the largest improvement in quality of life. By nature, the SuPER system is utilized in remote areas which mandate reliability and simplicity as critical considerations. Due to the predicted price of the

system, end users do not typically have the free capital to purchase the system, leaving non-profits as the likely middleman consumer. Their needs dictate the system be reasonably priced, easily assembled and installed, and compact. These criteria allow the organizations to provide more units in a faster time frame which increases the global impact. The customer needs addressed were determined by considering what capabilities would increase the user's quality of life the most.

Requirements and Specifications

Table 1: Cal Poly Super Microcontroller Integration Requirements and Specifications

Marketing Requirements	Engineering Specifications	Justification
2, 4, 5	Sensor data will be checked at least every 100us and allow real time monitoring through an LCD screen.	This allows the system to detect faults in the circuitry quickly and minimize potential damage.
3	Sensor data must be logged at a rate of at least 10 kHz	The system will store sensor data in order to track component efficiencies.
4	All sensor data logged and displayed will have a percent error less than 5%	Sensor accuracy lets the system respond appropriately and maintain ideal battery conditions.
6	Each microcontroller shall consume less than 15W.	This maximizes power deliverable to the loads and battery.
3, 6	The system must maintain a battery voltage greater than 85% during the day.	Maintaining a high battery charge prolongs the battery life, increasing system reliability and lifespan.
4, 5	Upon error detection, impacted elements will be disconnected in less than 10ms.	Preventing extensive damage in case of an error allows for easier repair or replacement. This also increases the user's safety.
3, 4	System must operate in the temperature range of -35C – 75C.	SuPER systems are meant to be deployed in developing countries which frequently have hostile climates.
3	Microcontroller and sensor elements shall be housed in waterproof casings.	These elements are likely to be exposed to precipitation and must be protected.
1	Microcontrollers and sensors shall cost less than \$60 total.	This reduces the total cost of the system.
Marketing Requirements		

1. Low cost
2. Easy to understand interface
3. Very reliable
4. Safe for all ages to interact with
5. Fast data communication.
6. Power provided for up to 3 days with no charging.

Microcontroller integration requirements presented in Table 1 are relatively straightforward. The microcontroller system must balance budget impact and performance. Interaction with the system to select displayed values must be intuitive as well as the system must be reliable over a long life time. Requirement 6 warrants more explanation, the system must track the battery voltage level throughout the day and disconnect a load if its power consumption indicates the battery voltage will drop below a threshold. In this case, the threshold condition states the battery must keep a charge sufficient for operating normal nighttime functions for at least three days with no charging [16]. Ideally, this minimizes the impact of cloudy days or storms and protects against loads consuming too much power to provide device charging and lighting at night.

Chapter 3: Functional Decomposition

Figure 1 depicts the level 0 block diagram of the system, inputs to the system are read and communicated between the Controller and Digitizer boards using an established communication protocol. Output signal functions include storing memory, ensuring safe operation, and maximized power conversion through the dc-dc converter. The MOSFET gate signals isolate subsystems under various circumstances, including: sensors indicate an error, current load power consumption might damage the battery life, or simply for maintenance. An LCD display can be implemented in the future and will allow users to display selected data in real time. In addition to the LCD display, code for a PWM signal was prototyped over the summer but as not been implemented in this version of the system. For more information on the PWM signal refer to Gesiel Soares report [17].

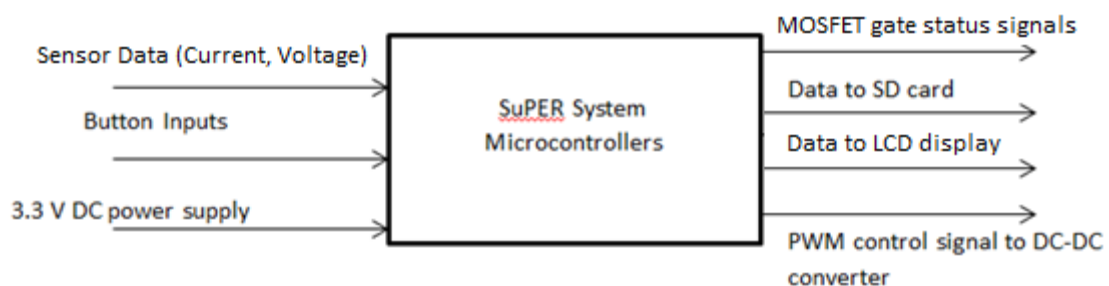

Figure 1: Level 0 Block Diagram

The functions of the level 0 block diagram contain the surface level inputs and outputs, Table 2 provides further explanation of each function.

Table 2: Level 0 Block Diagram Functions

Module	System Microcontrollers
Inputs	<ul style="list-style-type: none"> • Voltage and current sensor outputs which all will be less than 3.3V • Buttons integrated with microcontroller I/O pins, logic levels 0-3.3V • Power supply: 3.3 V DC
Outputs	<ul style="list-style-type: none"> • MOSFET gate signals: logic levels 0-3.3V • PWM signal to control converter impedance • Data transfer to SD card
Functionality	<p>The microcontrollers collect data from the system which is monitored for errors. Any errors detected cause appropriate MOSFET gates logic levels to change and isolate impacted components. Data is stored for long term efficiency analysis. Future versions of the system will allow users to select current sensor data to be displayed on an LCD screen using button inputs.</p>

Table 2 expands the inputs and outputs presented in Figure 1, including known voltage levels the system experiences. A level 1 block diagram in Figure 2 provides a more detailed breakdown, showing individual subsystems. In the current state of the system only the current and voltage sensor are utilized however a temperature sensor and pyranometer will be used in the final version to collect more data for system analysis. The Controller assess the MOSFET gate control signal through the Digitizer and command the Digitizer to toggle the signal as desired.

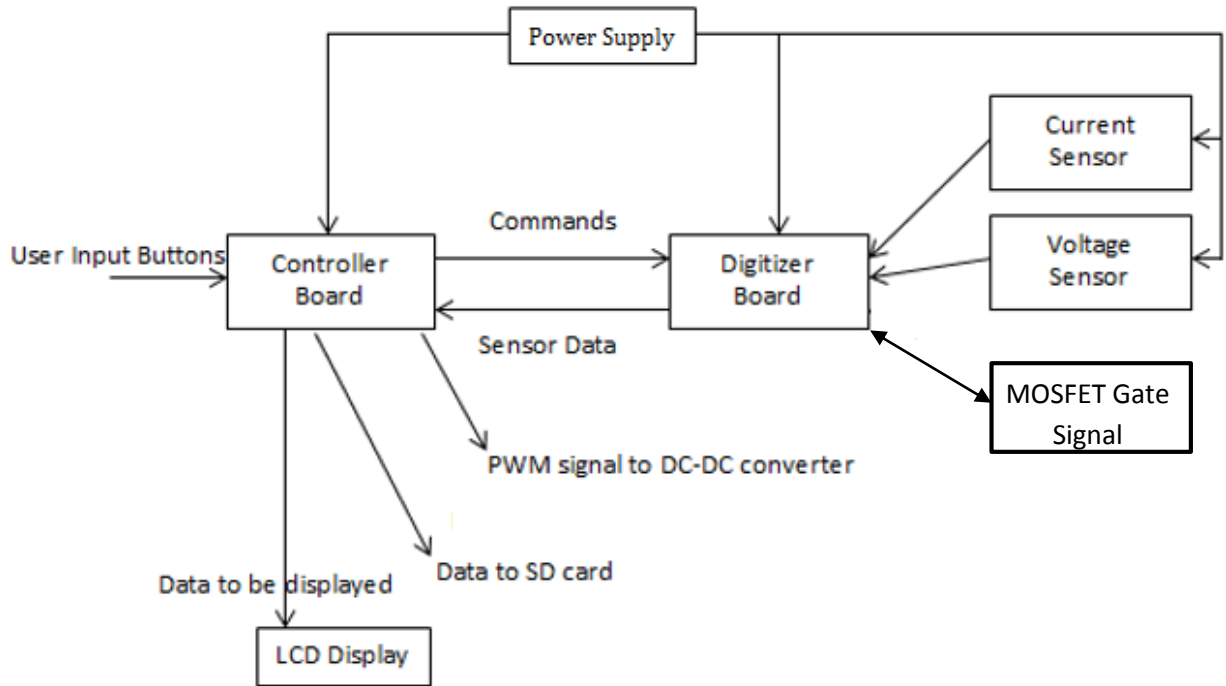

Figure 2: Level 1 Block Diagram

The level 1 block diagram details subsystems of the microcontroller project and additionally provides expected signals between subsystems. Table 3 provides an explanation of each function and its corresponding signals.

Table 3: Level 1 Block Diagram Functions

Module	Controller Board
Inputs	<ul style="list-style-type: none"> Buttons integrated with microcontroller I/O pins, logic levels 0-3.3V Sensor data from the Digitizer, binary logic Power supply: 3.3V DC
Outputs	<ul style="list-style-type: none"> Commands to Digitizer, binary logic Data for LCD display, binary logic PWM signal that modifies converter impedance for maximum power transfer MOSFET gate control signal to disconnect parts of the system as needed, 0-3.3V signal Data transferred to SD card

Functionality	The controller board serves as the brains in the system; it controls data collection by digitizer boards over an I2C communication line. Additionally the controller manages input selections by the user determining values displayed on the LCD. All data read from the digitizer and corresponding sensors is time stamped by the controller and transferred to an SD card. The controller monitors the system status and turns off the MOSFET gate switch if a part not operating correctly.
Module	Digitizer Board
Inputs	<ul style="list-style-type: none"> • DC voltage supply: 3.3V • Commands from controller, Binary Logic • Sensor data, 0-3.3V
Outputs	<ul style="list-style-type: none"> • Digitized sensor data to the controller
Functionality	The digitizer board processes the sensor outputs, creating digital sensor data that is more stable for sending across distances. The controller board sends inputs controlling when the digitizer transmits sensor readings.

Chapter 4: Project Planning

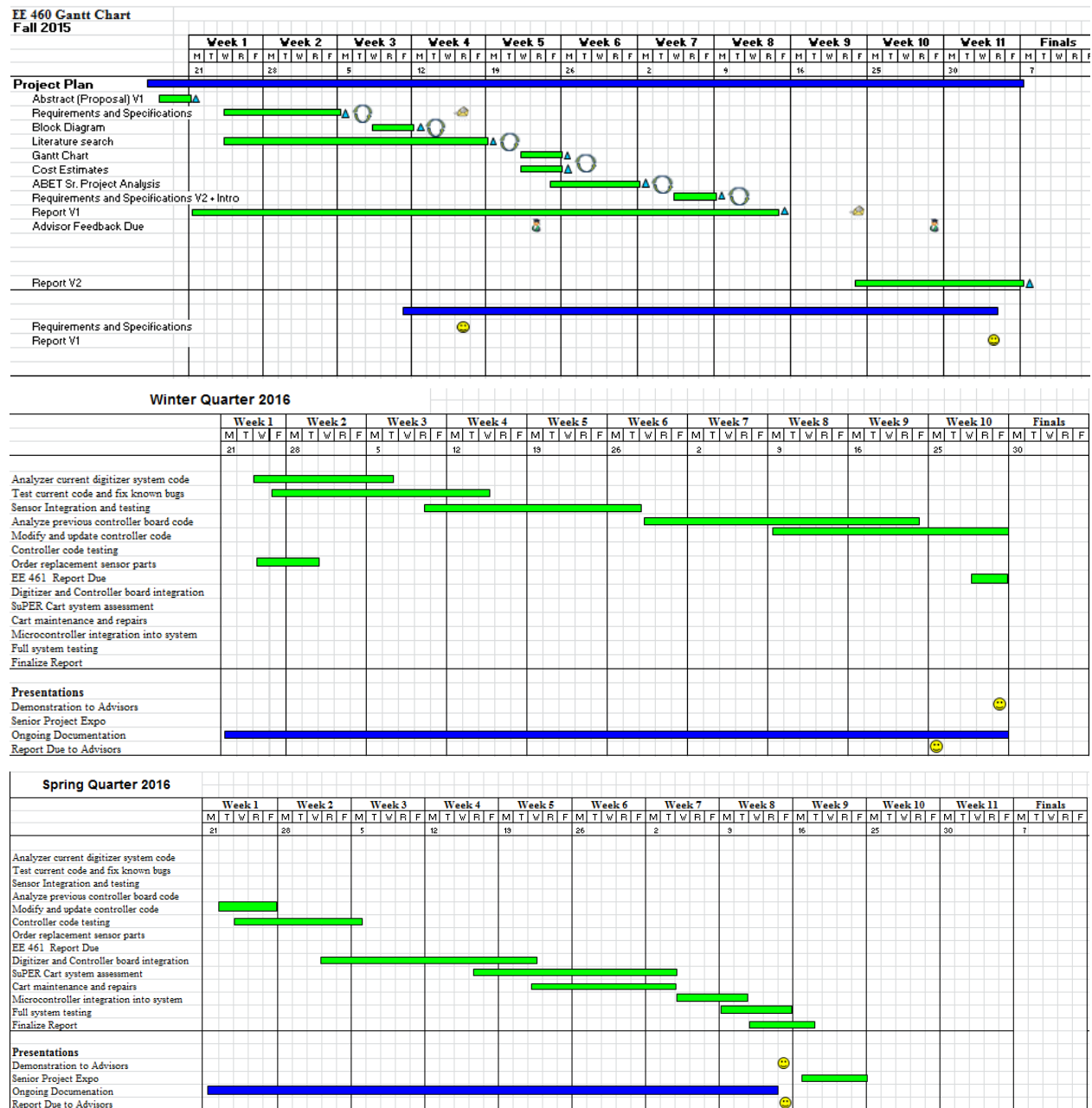

Figure 3: Gantt Chart

The Gantt Chart, Figure 3, represents a preliminary schedule of work, detailing both duration and progression of tasks. The expected progression of work includes multiple build and test iterations over the design process. Each subsystem's integration provides ample opportunities for debugging and verifying the circuit performs as expected. The preliminary goals turned out to be ambitious and the final goal of the project shifted towards establishing the microcontroller communication and data logging with cart maintenance and integration to

be completed by a future team. Table 4 depicts the known and expected expenses of the project.

Table 4: Costs Estimate

Component	Cost (totals)	Justification
Current Sensor (3)	\$25	The current sensors selected for the project are around \$6 each. Estimated shipping fees included.
Labor	\$3750	Estimated at \$25 an hour for a conservative 5 hours a week over 30 weeks.
Total	\$3775	This project is a continuation so most equipment is already purchased.

The current sensor specified in a previous report removes the need for the PERT estimation [11]. Recalibration and labor costs are calculated using the PERT estimation below where C is labor cost per hour and B is recalibration cost.

$$C = \frac{C_a + 4C_m + C_b}{6} = \frac{20 + 4 * 25 + 30}{6} = \$25/h$$

$$B = \frac{B_a + 4B_m + B_b}{6} = \frac{15 + 4 * 30 + 45}{6} = \$27.50$$

Table 5 contains estimated dates for various project demos, presentations, and reports.

Table 5: Cal Poly Super Microcontroller Integration Deliverables

Delivery Date	Deliverable Description
February 19, 2016	Design Review
March 30, 2016	EE 461 demo
March 30, 2016	EE 461 report
May 29, 2016	EE 462 demo
June 6, 2016	ABET Sr. Project Analysis
June 6, 2016	Sr. Project Expo Poster
June 9, 2016	EE 462 Report

Chapter 5: I²C

Background

I²C is a two wired communication protocol that sends serial data between two devices. Devices are classified as either a master or slave; however there can be multiple masters or slaves all sharing the same two lines. One line serves as the clock that synchronizes transmission between devices while the other line transfers data. Each slave is designated with an address that a master must transmit over the data line to specify when the following data transmission pertains to that slave. For further information on how to utilize I²C please refer to the Microchip datasheets.

Implementation

The SuPER system for this project utilizes one master, the Controller board, and one slave, the Digitizer board. The Digitizer is responsible for gathering sensor data to be transmitted to the Controller as requested as well as opening or closing MOSFET gates as instructed by the Controller in order to disconnect portions of the system if an error is detected. Microchip offers API's for the XC16 compiler that help streamline establishing communication. Previously the C30 compiler was utilized; however Microchip has stopped supporting the C30 compiler. The two compilers function very similarly for I²C; however, the C30 API's have better documentation. Referencing Clifford Susa's report for documentation on the C30 API's may be more helpful in understanding XC16's API's.

The I²C code for the Controller board is based heavily on the code developed by Clifford Susa but unfortunately Emmanuel Solorio's code for the Digitizer was not available to use as a reference. Susa's code has been modified to allow the master to write switch commands to the slave instead of only being able to read from the slave. For a more detailed analysis of I²C and research performed to understand the system please refer to the work complete over the summer of 2015 [16].

Figure 4 depicts the hardware connection for I²C. Both the data and clock lines need to be externally pulled up to VDD through a resistor as the microcontrollers can only pull the lines low. VDD can be supplied by either a 3.3V or 5V pin available from the Explorer 16 PICTail plus connector and according to Microchip the pullup resistor should be on the order of 4.7k Ω . The data line SDA is attached to RE7 on the PICTail plus connector for both the Controller and Digitizer while the clock line SCL is attached to RE6 on both.

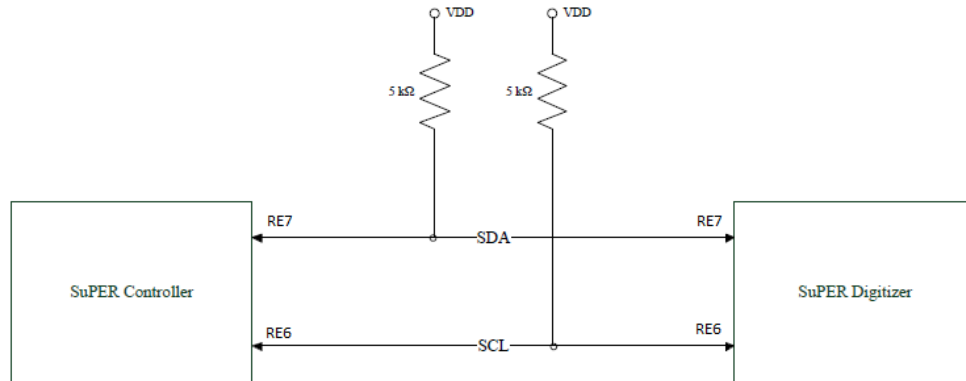

Figure 4: I2C Hardware Connection

Reading and writing have a similar structure with the only differences being when acknowledges or not acknowledges are sent and who sends them. Figure 5 shows an example of the master reading from the slave. While the I2C bus has been opened and is idling, the master generates a start condition followed by sending the slave address with the least significant bit being a 1 for read from the slave. If the slave recognizes the address it responds with an acknowledge and transmits the data byte. The master then sends either an acknowledge which signals the slave to send the next byte or a not acknowledge signaling it is done reading data and asserts a stop condition.

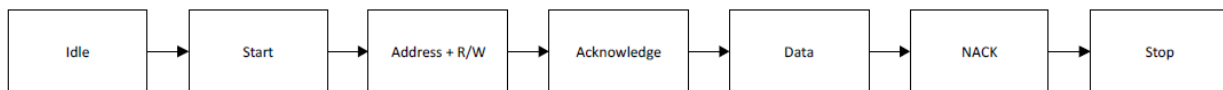

Figure 5: Master Read Software Flow

If a master is writing to the slave then the R/W bit is a 0, after the slave acknowledge the master transmits the data and waits for a slave acknowledgments. At this point the master can send another byte of data or generate a stop condition.

Chapter 6: Sensors

The PIC24FJ256GB110 microcontroller ADC channels have an internal reference source that operates from 0V – 3.3V; ADC channels can also use external reference sources but for now it is set up to use the internal source. If a sensor does not output in the same 0V – 3.3V range it can be scaled using a voltage divider circuit. This method is used for the current sensor utilized in testing; however, it is preferable that all sensors output at the same voltage range as using a voltage divider will introduce a small error into the system. Some ADC inputs appeared to not work as expected and it is encouraged that testing be done to confirm correct operation of any channel used in future version of the SuPER system. During development four ADC channels were verified as operating properly, the input pins for these channels are RB1, RB3, RB5, and RB8. More information discussing the system sensors can be found in the reports completed over the summer 2015 [16].

Voltage Sensor

The voltage sensor used for testing consists of applying a 0V – 3.3V signal across a resistor to test the ADC's response. Figure 6 depicts the simple method used to determine the ADC's accuracy while Table 6 provides a sample of data collected to verify the ADC's accuracy. In order to measure voltages higher than 3.3V, a voltage divider can be constructed. This will be necessary for measuring the voltage of the system as the battery operates around 12V and the solar panel operates around 40V. The Voltage divider can be constructed so that these voltages will generate a known voltage within the 0V – 3.3V range and changes to the system can be measured around these fixed points.

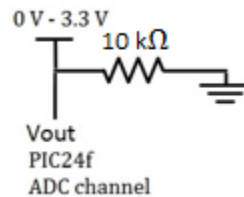

Figure 6: Voltage Sensor Circuit

Table 6: Voltage Sensor Readings

Real Voltage (multimeter)	Read Voltage (pic24f)	Error (%)
2.000 V	2.046 V	2.30 %
2.740 V	2.805 V	2.37 %
2.991 V	3.052 V	2.04 %

Current Sensors

The current sensor used was the ACS756KCA-050B-PFF-T, which is able to read currents from -50 A to 50 A, with a reading sensitivity of 40 mV/A when 5V is used for the forward supply voltage (Vcc). For more information on the sensor refer to the datasheet [13]. A RIGOL DP832 DC power supply was used to provide the current to test the sensors, 0.1 μF capacitors were used to keep the 5 V reference supply input voltage and the analog output voltage stable. Pins 4 and 5 were connected to the positive and negative inputs of the power supply. Finally, a voltage divider was used on the output of the sensor to scale the voltage given by the sensor of 2.5 V at 0 A to 4.5 V at 50 A to the values the PIC24F is able to read on the ADC channels, 0 V to 3.3 V, the resistors of the voltage divider were 520 Ω and 981 Ω, where the 981 Ω resistor would give a maximum of 3.3 V. The current sensor circuit diagram can be seen below in Figure 7.

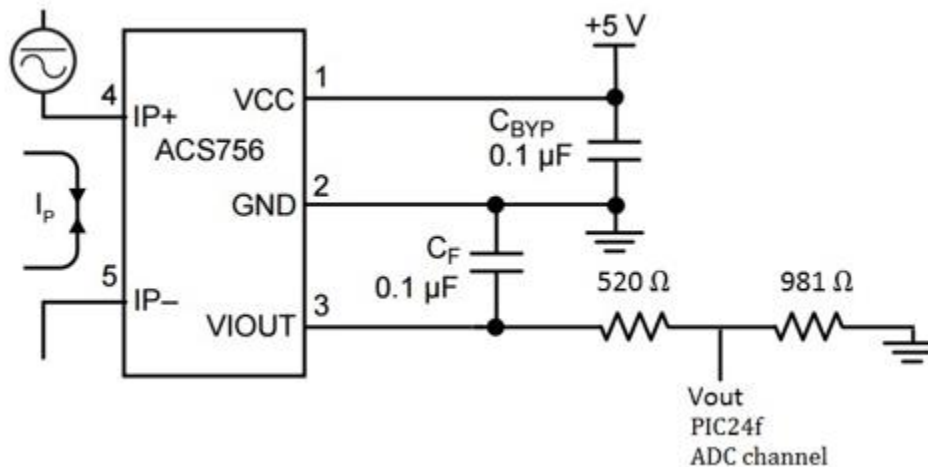

Figure 7: Current Sensor Circuit

Chapter 7: SPI and RTCC for SD Card Data Logging

Background

Serial Peripheral Interface (SPI) is a four wire communication interface used frequently to communicate with a Secure Digital (SD) memory card. While I2C only allows one device to communicate at a time, SPI operates at full duplex which means a device can accept data in while writing data out. The four lines of SPI are Serial Data In (SDI), Serial Data Out (SDO), Serial Clock (SCK), and Slave Select (SS). The SD card serves as a non-volatile memory card for storing collected sensor data once it has been transmitted from the Digitizer to the Controller. The Real Time Clock and Calendar (RTCC) stamps each set of data stored on the SD card with the date and time that it was read from the Digitizer in order to record the status and performance of the system. This data will be useful for monitoring how the system's efficiency changes over time as well as trouble shooting any potential failures in the system by seeing which sensors log abnormal values before the system responds to the error.

Implementation

The API's and Microchip demo code used in Clifford Susa's previous Controller board code to implement the SD card are no longer supported by the XC16 compiler. A new example, found in the Microchip Library for Applications (MLA) download, was used as a basis for developing the SPI communication for data logging on the SD card. Included in the demo is a method for timestamping the date and time the file was made, this code was modified to serve as the RTCC for the SD card and timestamps each set of data logged by the system. The RTCC used in the MLA example does not use the xc16 compiler API's; it creates its own RTCC.c and RTCC.h that directly address the registers controlling the secondary oscillator of the microcontroller. To understand the code please reference the PIC24F datasheet for the RTCC

registers. The SD card is mounted in a PICTail Daughter Board for SD and MMC cards. Figure 8 depicts the connections between the PIC24FJ256GB110 Microcontroller and the PICTail Daughter board for SD and MMC cards. For more information on the PICTail daughter board for SD and MMC cards please reference the datasheet and for information on the SD card demo provided by Microchip please reference the documentation provided in the MLA folder once downloaded.



Figure 8: SD Card Pin Diagram

Chapter 8: USB

Background

Universal Serial Bus is one of the most common methods of communication between devices and like SPI utilizes four lines: Data + (D+), Data – (D-), 5V (VBUS), and ground. In the SuPER system USB is used to view the SD card data directly on a PC without having to remove the SD card from the system. USB allows the file to be updated or edited from the computer and eventually data will be able to be viewed in real time.

Implementation

The Microchip example code used in the previous Controller board is not compatible with the XC16 compiler, the Microchip Library for Applications provides a new example; however, there appears to be an issue when using Windows 10 on the PC. Examining the example code's operation using a Salaea logic analyzer verifies that the Controller is trying to establish communication but Windows 10 gives no response and does not recognize the board as a device. Looking into the documentation provided with the file and the associated USB API's it appears that Microchip has not updated drivers to be compatible with Windows 10 as the documents only refer to using Windows 7 and 8. The underlying issues appears to be the device cannot be signed by the drivers which causes it to be unrecognized. Microchip has not responded to an email inquiring when this issue will be addressed. In lieu of data monitoring

through USB, the SD card must be manually removed from the PICtail Daughter Board for SD and MMC cards and be inserted directly into a PC.

Chapter 9: System Testing and Results

Testing of the I2C and SPI-SD card as mentioned previously has shown both features work separately. The I2C is able to both read and write as needed, eliminating the errors left over from work completed during the summer 2015. The SPI-SD card interface is able to log data and generate an associated time stamp for each sample. Integrating these two capabilities into one Controller board code has proved problematic. The compiler is able to recognize and trace the .h and .c files used but it signals errors in the make-file when the code is compiled. The error generated offers no explanation and there is no relevant Microchip documentation addressing compiler errors associated with the make-files. After discussing this issue with the project adviser it seems this error stems most likely from another version compatibility problem. This error was discovered too late in development to be adequately addressed. Please refer to appendix 2 for more details about the files found on the USB flash drive and their development status.

Chapter 10: Conclusions and Recommendations for the Future

The control system for the system has been established and both boards are able to communicate with each other. This project has updated the prototype developed by Clifford Susa and Emmanuel Solorio and serves as a solid foundation for future development. Testing performed at this stage is functional testing and further testing of the system should be performed to determine the maximum speed of communication over I2C which determines the maximum data speed of the entire system. As mentioned previously the USB capabilities are currently unavailable as the drivers appear to be incompatible. The examples of USB communication provided by Microchip's MLA folder will be relatively straightforward to implement into the existing code when updated drivers and documentation is available. Work completed over summer 2015 analyzed use of pulse-width modulated signal for controlling the DC-DC converter present in the system, in this current build the signal is not implemented. Please refer to Gesiel Soares' report for more information if this feature is desired in future builds [17].

Future development might find it useful to develop look up tables for sensor readings instead of performing calculations like the current code. This will allow for a more responsive system and faster data collection if desired. Currently the system senses only current and voltage but this can be easily expanded upon to meet the needs of the full system as it is integrated into the cart. Suggested next steps for SuPER's development are assessing the status

of the cart, removing old components/integrating the microcontrollers and sensors, followed by system testing.

One issue that has become clear over the course of this project is that Microchip is moving away from the PIC24 family of microcontrollers. Updated documentation and example codes for the PIC24 family is difficult to find and often unclear. Microchip appears to be focusing on developing their 32 bit microcontrollers instead of maintaining adequate support for 16 bit families. This suggests moving towards a 32 bit microcontroller. Future development teams might even want to consider moving away from microcontrollers in order to avoid issues that arise with version updates.

References

- [1] A. M. Pernía, J. Arias, M. J. Prieto, J. Á. Martínez, A modular strategy for isolated photovoltaic systems based on microcontroller, *Renewable Energy* Volume 34, Issue 7, July 2009, Pages 1825–1832.
- [2] N. Amin, L. Z. Yi, K. Sopian, MICROCONTROLLER BASED SMART CHARGE CONTROLLER FOR STANDALONESOLAR PHOTOVOLTAIC POWER SYSTEMS, *Photovoltaic Specialists Conference (PVSC), 2009 34th IEEE*.
- [3] C. Susa, Controller Board Prototype Development for the Cal Poly SuPER Project, Senior Thesis Cal Poly San Luis Obispo, 2011, Cal Poly Digital Commons.
- [4] E. Solorio, AN EMBEDDED SYSTEMS PROTOTYPE SOLUTION FOR CAL POLY'S SUPER PROJECT DIGITIZER BOARD, Senior Thesis Cal Poly San Luis Obispo, 2011, Cal Poly Digital Commons.
- [5] Microchip Technology inc., PIC24FJ256GB110 Family Data Sheet, 2009, <http://ww1.microchip.com/downloads/en/DeviceDoc/39897c.pdf>, October 10, 2015.
- [6] P. Corcoran, Two Wires and 30 Years, *Consumer Electronics Magazine*, IEEE Volume: 2, Issue: 3, July 2013, Pages: 30 – 36, Available: http://ieeexplore.ieee.org.ezproxy.lib.calpoly.edu/xpls/abs_all.jsp?arnumber=6556004&tag=1
- [7] Microchip Technology inc., Inter-Integrated Circuit™ (I2C™), 2007-2014, <http://ww1.microchip.com/downloads/en/DeviceDoc/70000195f.pdf>, Accessed October 17, 2015
- [8] C. Fu, S. Te, C. S. Tung, Short circuits and power limit protection circuits, U.S. Patent 9,054,527, March 14, 2013
- [9] M. A. Mazidi, PIC microcontroller and embedded systems: using Assembly and C for PIC18, upper Saddle River, N.J., Pearson Prentice Hall, 2008
- [10] Nasa Earth Observations, Solar Insolation, http://neo.sci.gsfc.nasa.gov/view.php?datasetId=CERES_INSOL_M, accessed: October 14, 2015
- [11] J. Harris, White Paper for Sustainable Power for Electrical Resources – SuPER, July 15, 2005

[12] J. Stumpf, Climate impacts of kerosene lamps used in developing countries, Environmental Factor, National Institute of Environmental Health Sciences, January 2013, accessed: November 11, 2015

[13] Allegro. ACS756xCB. *Fully Integrated, Hall Effect-Based Linear Current Sensor IC with 3 kVRMS Voltage Isolation and a Low-Resistance Current Conductor*. Datasheet. Web. August 2015. < <http://www.allegromicro.com/~Media/Files/Datasheets/ACS756-Datasheet.ashx>>.

[14] Microchip. "PICtail Daughter Board for SD and MMC cards." Datasheet. Nov. 2008. Web. April 2016. <http://ww1.microchip.com/downloads/en/DeviceDoc/DS-51583b.pdf>

[15] E. Tal. SuPER System Prototype Design and Implementation, Master Thesis, Cal Poly San Luis Obispo, 2006, Cal Poly Digital Commons

[16] E. Skinkis, G. Orsi, T. Cardoso Orsi, T. Valadares Ribeiro. "Cal Poly Summer Project – SuPER Project", Cal Poly San Luis Obispo Aug. 2015

[17] Gesiel Soares. "Cal Poly SuPER System photovoltaic array ADC, PWM and Gate Driver", Project Report. Cal Poly San Luis Obispo Aug. 2015

[18] Gesiel Soares; Gustavo Ramos de Paula; Thiago Fernandes. "Cal Poly Summer Project SuPER Project Sensors", Project Report. Cal Poly San Luis Obispo Aug. 2015

Appendix 1 Development Lessons Learned

A. Updated Versions

There were 3 separate instances of updated versions creating issues during this project. The first change came in using the newer xc16 compiler instead of the c30 compiler previously used. Some aspects of the code, like the I2C API's, were not affected greatly but other aspects used completely different API's. This made it difficult to use older code as a reference and meant development needed to be done from scratch. A second instance is that during development a new version of the xc16 compiler was released, Version 1.25; however this updated version did not include peripheral libraries for I2C. It is unclear why Microchip would remove this as a standard feature but it can be downloaded and included as a legacy peripheral file. For ease of development the xc16 version 1.24 was used instead. The third update is the Microchip Library for Applications, previous versions of the Controller used examples found in this file extensively as a building block of the code; however these examples in the current version are very different. This meant once again that development needed to be done from scratch.

B. I2C

I2C presented the largest challenge of the project and a significant portion of time went into troubleshooting errors in the communication. It is recommended that future teams read the Microchip datasheet detailing the registers involved in setting up the process. There is a lack of examples for the PIC24F family which made it difficult to design, specifically for the slave. For more information on difficulties encountered please reference work completed over the summer 2015 and Susa's report [16] [3].

C. SPI & RTCC

The SD card reader example found in the MLA folder uses numerous libraries that are not included in the xc16 compiler which necessitated slowly copying and transferring each file included in the example. While not explicitly difficult this was a time consuming task.

D. PIC24F Family

Microchip seems to be moving past the PIC24F family of microcontrollers which has made finding updated documentation more difficult. In addition to documentation, examples or forums discussing problems encountering trying to implement various features with the PIC24F are scarce. Nearly all sample codes available use the old C30 compiler, the compilers are similar enough that these can be helpful references but typically cannot be used directly.

Appendix 2 Code

The Controller and Digitizer code has been saved in a USB flash drive and can be obtain by contacting Dr. Jim Harris or Dr. Ali Shaban. In addition to the Controller and Digitizer code the flash drives contains copies of the xc16 version 1.24 compiler and MLA file containing sample code used in this project. The Controller code is labeled Master_Code_noSD, Digitizer code is full_slave_code. The Controller_withSD file represents the integrated I2C and SPI-SD card code that could not be compiled. SPI-SD code relies on libraries found within the MLA file.

Appendix 3 ABET Senior Project Analysis

Project: Cal Poly Sustainable Power for Electrical Resources (SuPER) Microcontroller Integration
Eric Skinkis

Advisors: Ali Shaban, Jim Harris

Functional Requirements

The full SuPER system harvests solar power and delivers the energy to both a battery for storage and current loads to the system. The functional requirements associated with the project include that the system must maintain battery voltage sufficient to operate through three normal use night cycles with no charging. Also, the system must monitor and disconnect loads if the rate of power consumption jeopardizes the previous requirement. The system operates on one controller board and any number of digitizer boards. The digitizer boards

collect sensor data and convert to digital data, allowing an easier transmission over distances to the controller. The controller board analyzes the collected data and maintains system status. For this project the communication and data logging capabilities of the microcontroller have been developed. With future development, the microcontrollers will be able to control status include impedance matching the dc-dc converter, ensuring maximum power transfer, as well as determining which loads can be used and still maintain a sufficient battery voltage.

Primary Constraints

Constraints on the project stems primarily from lack of manpower, having additional members would greatly speed up coding and testing the system as multiple components could be developed in parallel. An additional constraint comes from having to incorporate this design into an existing system which limits the possible design choices as it must integrate into the existing system. Interfacing between multiple systems requires referencing different senior projects reports, a time consuming process. Also, the existing system had been left to deteriorate meaning extensive work analyzing and repairing the system needed to be completed prior to full system testing. Work completed on repairing the system reduced the time available to spend on improving the system. This, coupled with a lack of manpower, proves time as the largest constraint to the project. An accumulation of parts from past projects minimizes financial constraints though the desired total price point of under \$500 necessitates minimizing further spending. Current component costs leave an estimated \$100-175 for unforeseen components and packaging.

Economic Impact

Given the nature of the project, SuPER has a potentially large economic impact. In terms of human capital, previous senior project's and master's thesis put cumulatively thousands of person hours into the system and likely more projects after mine must be completed before reaching a final design. This makes the project intensively demanding on human capital during the design and development stage. Once the final user has a system providing them basic electricity it indirectly generates human capital. Laptops and cellphones allow for affordable and accessible education that over time increases the human capital by creating a more informed and educated community.

The financial capital is not extensive during development due to relatively inexpensive components and a large accumulation of equipment gathered over the system's lifetime. By enabling people to power laptops and cellphones, SuPER fosters communication in and between communities which extrapolates to increased business connections and opportunities, increases financial capital in the area. One goal of the project is to add to the natural capital as harvesting solar power for energy helps reduce developing nation's dependence on unsustainable sources of energy. Realistically the project will still produce a negative impact on

natural capital due to harvesting resources to produce the system and pollution associated with transporting the materials.

Most costs associated with the product stem from the time and money put into development, with very little costs after purchasing. The benefits however are enormous as families with access to reliable electricity see an increased quality of life. The main operating assumption is that the costs would not be shifted onto the final consumer, as the price could be outside the target demographics capability, but marketed towards nonprofits that will absorb the costs. The SuPER system has a projected delivery date of around 2020, after completion of microcontroller integration the system enters a final debugging and package designing stage, followed by certification that allows the system to enter production [11]. The product designs estimate a 20 year lifetime between major repairs and minimal operation costs since it produces its own power. Maintenance costs could be costly as delivering and repairing parts in remote areas creates a possibly large logistical problem, this drives the design for a long time between repairs. Distributing units through nonprofits has the added benefit that supply lines to these remote sites already exist for distributing aid; this simplifies the issues associated with maintenance but does not greatly reduce the need for a long lifetime as paramount in the design. After integrating the system's microcontrollers, refining the system represents the final challenge. This entails extensive testing of the full system to eliminate bugs and designing the system's final packaging.

If Commercially Manufactured

The SuPER project designs consider simplifying manufacturability. Most likely, the consumer would be nonprofits who would purchase the units to be donated to communities in developing countries where the system would have the most impact on quality of life. Using a modest production line allows an estimated 1000 devices manufactured and sold per year at an estimated manufacturing cost of \$400. A target purchase price range of \$500-\$550 leaves a profit of \$100k-\$150k. A target device lifetime of 20 years between major repairs and essentially around the clock operation leads to an estimated cost of 0.075 cents per day if the unit costs \$500 [11]. Target final recipients may have trouble affording this price which makes minimizing manufacturing costs vital unless nonprofits are chosen as the sole target. The commercial manufacturability must be reassessed after completing the full design.

Environmental

The SuPER system has an unavoidable negative impact on the environment; however it lessens this impact over time. The negative effects associated stem from the harvesting of raw resources to make the components and the pollution from transportation of the relatively large system. While initially taxing on environmental resources, SuPER seeks to offset these negative impacts. Ideally the product produces a positive environmental impact over its lifetime as

households would have access to clean LED light instead of the standard kerosene lanterns frequently found in developing countries. The kerosene lamps produce black carbon emissions that contribute to global warming and can cause adverse health effects from prolonged inhalation in closed spaces like houses [12]. SuPER's reduction of kerosene lanterns lessens the negative environmental impact inherent in production but like most products a net positive environment impact proves elusive. SuPER should have a minimal impact on other species aside from initial resource harvesting that may impact surrounding environments. This impact can be avoided by choosing suppliers committed to conscientious harvesting of resources.

Manufacturability

Manufacturability for the micro-controller and sensor aspects of the system scale well and prevent no large issues since they consist of purchased components, but large scale manufacturing would prove difficult with the designed dc-dc converter. The system largely uses off the shelf components which leads to easy assembly. The final unit's packaging most significantly impacts the manufacturability and as the system currently exists in a prototyping stage that does not represent a final product. Creating packaging durable enough for remote and often harsh environments will likely reduce the manufacturability of the system but is necessary [11]. A full analysis must be performed after completing the SuPER system design to create an easily manufactured system.

Sustainability

Target markets for the device require the system to operate in hostile and remote environments where an electrical grid is not feasible. This necessitates a very reliable system since repairs present a large logistical problem. Since nonprofits represent the most likely customer, a budget for repairing systems probably does not exist. Considering these constraints, a desired average time between extensive repairs of 20 years has been integral in the design in order to manage these possible maintenance issues. A useful improvement to the design includes using a solar panel with a higher power rating, allowing more power hungry loads such as refrigeration. Increased costs for more powerful panels limits the improvement but advances in technology help offset costs. The current DC-DC converter used by SuPER needs redesigning to accommodate a significantly more powerful panel [3]. The challenges associated with upgrading the design stem from the difficulty of cross-referencing all impacted circuits to verify new parameters do not exceed the old circuit limitations. This is difficult because each component corresponds to a separate report, making research a time consuming task.

Ethical

There are limited ethical concerns associated with the SuPER system since its goal is to increase the quality of life for its users. Seeking to provide a reasonably priced system capable of providing basic electricity to households without prior or reliable access has little negative aspects. IEEE's code of ethics outlines 10 ethical points that the system adheres to. The microcontrollers address safety concerns by disconnecting an element of the circuit upon fault detection which minimizes the chance of electrocution. No conflicts of interest are currently present in the system, nor do they seem likely to arise. All data from previous work on the project and current performance characteristics is documented and reproducible in accordance with creating realistic claims. Bribes pose no threat to an independent research projects. Each successive project seeks to further improve the understanding and performance of the system. Responsibility for IEEE's criteria of availability to all persons falls more on the non-profits that distribute the system.

When scrutinized according to other ethical frameworks, the system also passes as ethical. For example, under Utilitarianism, the system actively seeks to promote the greatest good for the greatest number by improving the quality of life. The system provides reliable and high quality lighting, improving conditions of the household at night, in addition, devices can easily be recharged which allows more use of phones and laptops. This enables global contact and awareness and especially an opportunity for educating children in their own house using educational programs. Additional features include the possibility to mount a motor, pump, or small refrigeration device, all of which greatly expand possible uses of the system.

Possible ethical concerns associated with SuPER are addressed in the social and political analysis since the concerns stem more from political and social instability of the regions systems ideally operate in. Instability makes bribery, corruption, and theft possible threats during the distribution and eventual operation of the systems; while this poses an ethical issue, no changes to the project design impact them so they do not affect ethical concerns with the SuPER system.

Health and Safety

The only safety concerns with operating the product include the possibility for electric shock or fire if a component fails. As stated previously, the system monitors each subsystem and can isolate a system if sensors indicate an error. Isolating the system should minimize these potential hazards and make the system safe for use even by young children. Safety features are not the priority during this prototyping stage. System safety features, such as disconnecting components upon detection of an error, are being developed but a true analysis needs to be completed during the packaging design in order to pass code and create a safe system. SuPER can positively impact the health of consumers by reducing potentially hazardous chemicals inhaled from burning kerosene as described earlier [12].

Social and Political

The project should not have direct negative social or political impact as the goal is magnanimous. A possible political concern could arise during a nonprofits selection of country to donate the product to and can be refined further to concerns between neighboring communities receiving the aid while others do not. This might create an inequality and most likely anger those who do not benefit. A fair method would need to be developed to determine how to distribute each system so that they would not be destroyed or stolen due to jealousy or economic gain. Measurable impact of the system increases over time if it allows children easier access to education and information. Socially, SuPER has the potential to increase equality given the increase in access to information and education described earlier. Allowing widespread access to the internet and online educational tools greatly increases the chances of a disenfranchised community achieving better lives. Families that receive a SuPER system represent the direct shareholders with the donating nonprofits as the indirect shareholders. Indirect shareholders also include members of the international community who benefit from increased business opportunities resulting from the increased communication and education abilities of a community. Families that receive a system benefit the most, especially since charities cover most if not all of the expenses. The charities receive little tangible benefits; however this corresponds with the core concept of a charity and poses no problem.

Development

Research has gone into understanding dc-dc controllers and how to match its impedance using a PWM signal. Additionally, research has gone into maximum power point tracking and establishing a communication protocol between microcontrollers. During development, extensive research was put into understanding the evolution and most recent build of the SuPER system as well as research into I2C, SPI, and USB communication protocols.