

USB Turntable

“TurnT”

by

Gerardo Sevilla
James Lougaris

EE 462 Report
Electrical Engineering Department
California Polytechnic State University
San Luis Obispo
2016

Abstract

The idea of this project is to create a truly portable turntable system which runs on USB power alone. The USB interface will also allow the user to transfer their albums to a digital format. The final design will be a portable turntable which features exceptional sound quality which can be transferred over USB to a computer or the RCA phono jacks to a stereo system. The design will also not require an external power supply or power cord. This solution will provide a more convenient and higher quality vinyl experience in contrast to the systems currently on the market.

The turntable should be capable of running on 5V 500mA USB power and provide audio output over USB and RCA phono jacks. The system will consist of a modified turntable with a USB interface component, a built in pre-amplifier, and a high quality stylus and cartridge. The system will be housed in a custom fabricated enclosure with the following key features:

- USB connector
- RCA Phono Jacks
- Power Switch
- Speed Selector Switch
- High Quality Stylus and Cartridge
- Plays 33 and 45 RPM records (12" and 7")
- Plug and Play

Introduction

In EE 462 the group created a working prototype from the research and plans created and outlined in the EE 460 class. The prototype was created using the mechanical parts of a Crosley executive and custom electronics for handling the audio. Throughout the quarter there were many ideas tested and many plans that failed, however the group has successfully created a working prototype. The TurnT prototype has the ability to play vinyl media with the use of a single USB cable. The audio can be played back through the computer's audio hardware or through the RCA ports.



Figure 1: The Prototype

The Market for the Device

2015 vinyl sales increased even further from previous years reaching over \$400 million, a 26-year high. Many consumers are turning back to vinyl as a way to listen to their favorite albums. Some appreciate it for the warm analog sound, while others enjoy the retro look and style of playing an LP. In the table below the different customers that will likely be interested in the device.

Table 1: Customers for the Turnt.

	Description	Reason	Product Use
Hipsters	Subculture associated with young middle class bohemians who enjoy indie and alternative music and search for non-mainstream styles and vintage clothing.	They tend to find music which others have never heard of and will purchase it in formats different than those of their mainstream counterparts	<ul style="list-style-type: none">● portability and simplicity of a USB powered turntable.● many indie bands have released new material on vinyl
Music connoisseurs	People that enjoy the warm sound of analog vinyl and often have been collecting for years	They have amassed large collections of CDs, tapes, and vinyl	<ul style="list-style-type: none">● A high quality USB powered turntable● Ability to copy their vinyl collections to a digital format without any loss in quality.

<p>Generation X</p>	<p>Those that have lived through the boom, decline, and resurgence of the vinyl format. People born in this era grew up listening to their favorite songs through vinyl.</p>	<p>They will often still have their vinyl collections and will break out their old turntables for the nostalgia</p>	<ul style="list-style-type: none"> ● A more simple plug and play solution ● Many bands from the past that they loved have released new albums in recent years through vinyl
<p>Technology buffs</p>	<p>Technology buffs are often early adopters and will look for new and exciting products for them purchase and play around with, analog or digital it interests them all.</p>	<p>A turntable which requires only USB power will be of utmost interest to them</p>	<ul style="list-style-type: none"> ● They will be curious about how it works and how they can use it themselves ● Interested in converting their old albums into digital.

Business Aspects

Table 2: Business model canvas

<p>Key Partners</p> <ul style="list-style-type: none"> ● Record Stores ● Hipster Retail ● Music Entertainment stores ● Electronic Retail 	<p>Key Activities</p> <ul style="list-style-type: none"> ● Working turntable powered by USB 	<p>Value Propositions</p> <p><i>Gains</i></p> <ul style="list-style-type: none"> ● No external Power needed ● Portable ● High Quality ● Analog to digital <p><i>Pains</i></p> <ul style="list-style-type: none"> ● Portability ● Music Quality ● Manipulate audio digitally 	<p>Customer Relationships</p> <ul style="list-style-type: none"> ● Social Media ● Online Ads Catered to music ● Ads at Retail Shops 	<p>Customer Segments</p> <ul style="list-style-type: none"> ● Hipsters ● Music Connoisseurs ● Generation X ● Technology Buffs
	<p>Key Resources</p> <ul style="list-style-type: none"> ● Music Connoisseurs 		<p>Channels</p> <ul style="list-style-type: none"> ● Large scale distribution 	
<p>Cost Structure</p> <ul style="list-style-type: none"> ● Website development/maintenance ● Warehouse maintenance ● Shipping cost to Retail 		<p>Revenue Streams</p> <ul style="list-style-type: none"> ● Retail Profit 		

<p>Social & Environmental Cost</p> <ul style="list-style-type: none"> ● Vinyl isn't readily available ● Dying form of media 	<p>Social & Environmental Benefit</p> <ul style="list-style-type: none"> ● Customer convenience able to listen and convert to digital easily
--	--

Several companies already offer USB turntables, and there is a variety of different models available in the market. Ion, Audio-Technica, Crosley, Jensen, TEAC, and Pyle are the most popular brands. Some of these systems include other features such as built-in speakers, AM/FM radio, and unique aesthetics. Most of these systems, with the exception of those with battery packs, are difficult to use far from an outlet. Very few systems on the market today are powered solely by USB. Many of these are far more expensive and not readily available to the everyday vinyl enthusiast. The TurnT will be a truly portable system which will need to be available at the

same retailers as other systems. Starting with local stores and online stores will be key to generating sales of the TurnT.

The product will sell for \$109.99. This price will cover the cost of materials four times over, specifically the motor and the cartridge. Many of the competitions' products range from \$99.95 - 149.99 placing the TurnT at the lower end of the price spectrum. The TurnT's portability and high quality will be a key feature but available at a lower price point.

The Final Product

Table 3: Engineering Specifications.

	Engineering Requirement	Marketing Requirement Met	Reasoning
1.	The system consumes less than 2.5W of power at any given time. The current used never exceeds 500mA.	USB Power Plug and Play	The Universal Serial Bus 2.0 specification requires devices to not draw more than 500mA of current at any time.
2.	8" Platter directly driven by a brushless DC motor with adjustable speed.	Plays 12" or 7" vinyl at 33 or 45 RPM.	The turntable must be able to rotate at exact speeds for accurate sound reproduction and will be powered by DC current.
3.	Diamond tipped stylus with ceramic cartridge.	Quality Stylus and Cartridge	In order to produce high quality playback, the stylus and cartridge must be high quality.
4.	The system contains a set of stereo RCA jacks outputting audio from the cartridge at line level.	RCA Phono Jacks	Many consumers will want to use their turntables without their computers present.

5.	The product is “” x “”x “”	Portable/Plug and Play	The device will be used in different spaces where there will be limited room due to its portable nature. It needs to be small enough to fit on a desktop or side table.
6.	Production price is about \$50.	Price	The product must be priced competitively enough to bring more casual listeners and audiophiles.

Functional Decomposition:



Figure 2: Level 0 Functional Decomposition Block Diagram

The turntable needs only a powered USB port to operate. The use of a computer is entirely optional. Audio will output over both USB and the rear RCA jacks.

Build

The main concern of the initially was the motor conforming to the low current requirement. After testing of the motor commonly found in Crosley turntables can both handle the 5V requirement, and will not overload the USB bus. In table 4 below, the motor stays well below 500mA.

Table 4: Turntable Current Measurements Based on Speed

Speed (RPM)	Starting Current at 9V (mA)	Starting Current at 5V (mA)	Average Current Draw at 9V (mA)	Average Current Draw at 5V (mA)	Stall Current (mA)
33 1/3	35	41	31	33	127
45	38	40	36	35	133
78	69	68	46	43	138

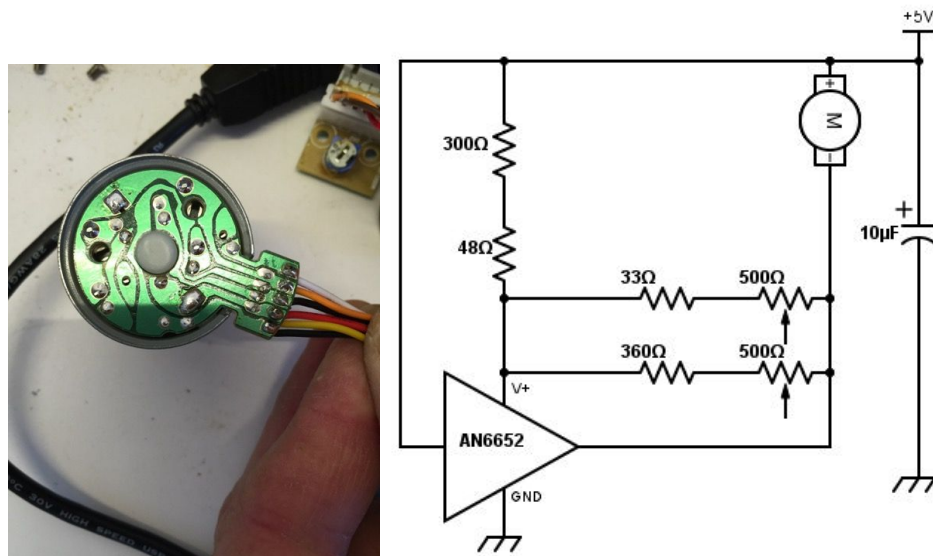

Figure 3: Motor control circuit.

Motor Constants:

K_1 : Generation Constant=2.4mV/RPM

R_a : Internal Resistor=18Ω

K_T : Torque Constant=200g·cm/A

The next step was creating the buffer circuit for the turntable to ensure the cartridge was properly loaded and the audio properly levelled to produce the correct frequency response and output line level audio.

Table 5: Final Buffer Design Characteristics

	Impedance
Input	1.16 M Ω
Output	70 Ω

The buffer circuit design is a basic voltage follower op-amp circuit with the single 5V supply turned into a split supply using a virtual ground. High input impedance is key for ceramic cartridges. Most modern audio inputs do not offer high enough impedances to properly work with ceramic cartridges.

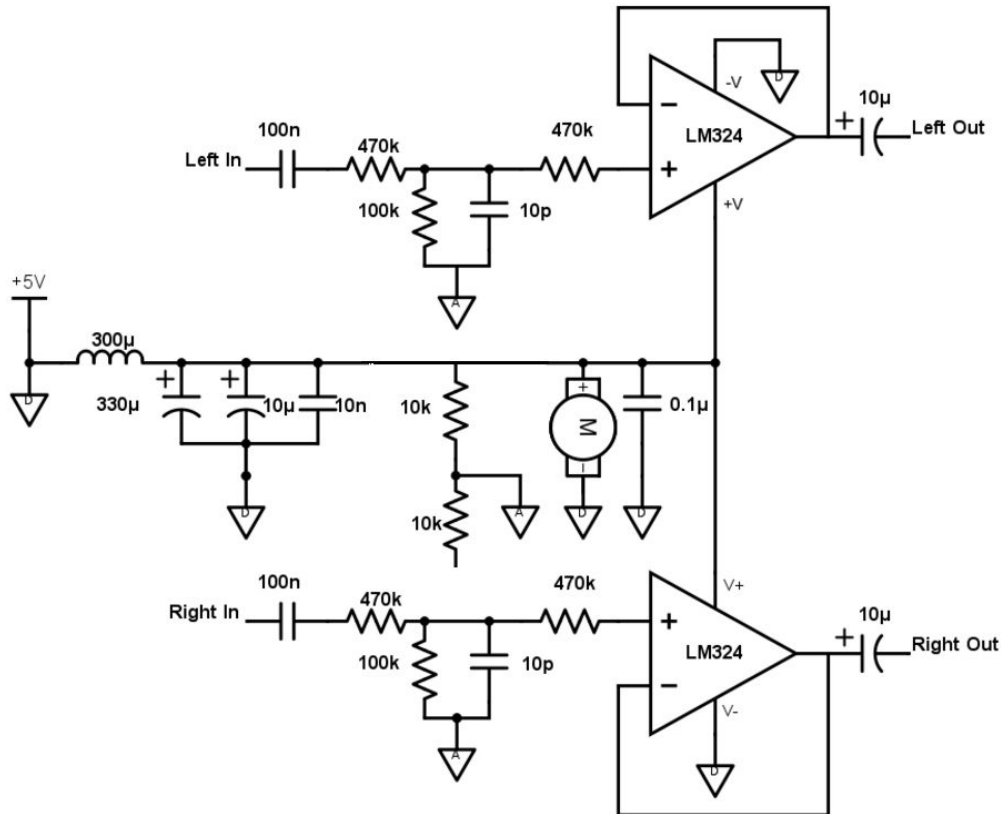
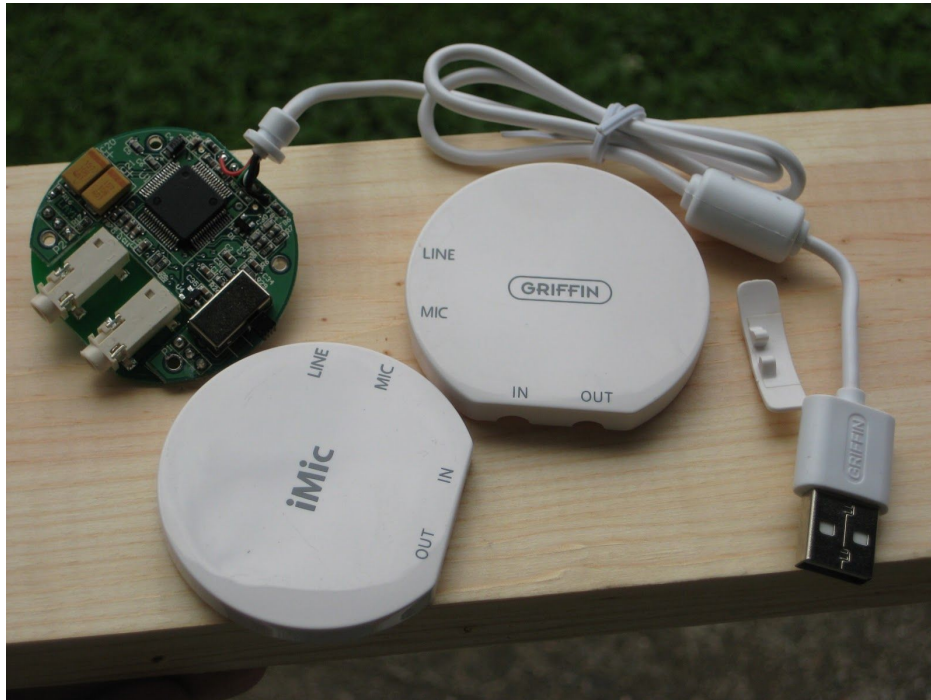

Figure 4: Buffer circuit diagram.

The Griffin iMic was used for the USB audio interface to allow the device to be seen as a recording input to both Windows and Mac OSX operating systems as well as some Android devices.



The iMic is a device which creates a line level input to any computer. The board was used in the TurnT to pass the audio from the cartridge to any computer. The main board was removed to from the enclosure, the 3.5mm jacks were removed, as well as the USB cable. The board was soldered to the audio protoboard. The audio output from the buffer was attached to the input of the iMic board, and the USB interface was wired to a USB type B port which was also soldered to the board. The result was a full fledged USB-powered turntable.

Bill of Materials

Part Description	Distributor	Part #	Quantity	Unit Price	Total Price
DC Motor	Amazon	hyejet model	1	\$20.00	\$20.00
Stylus & Cartridge	Ebay	--	1	\$1.25	\$1.25
USB Interface	Amazon	Griffin Technology iMic	1	\$39.97	\$39.97
Phono jacks	Parts Express	090-278	1	\$2.25	\$2.25
Buffer Components					
Audio Amplifier	Mouser	595-LM324N	1	\$0.58	\$0.58
Resistors	Mouser	--	8	\$0.10	\$0.80
Capacitor	Mouser	--	10	\$0.20	\$2.00
Inductor	Mouser	--	2	\$0.59	\$1.18
					\$68.03

Improvements and Conclusion

The design of the TurnT could be improved in a number of ways. The main necessary improvement for the system is audio quality. The current audio output has noticeable motor noise bleeding into the audio channels. Once that issue is taken care of the next goal would be to change the tone arm to accommodate a moving magnet or moving coil cartridge. Such a cartridge would have a high quality and more rich sound. A new audio circuit would be required as the output from such a cartridge needs extra amplification and equalization. This addition would create a product that would be well above current available solutions.

It may also be possible to add a Bluetooth interface. This would be an excellent feature which could set the turntable apart from many others on the market and greatly add to its portability. A simple external, or possibly internal, battery pack could be added as well as a microcontroller and Bluetooth module which would allow for the unit to be connected directly to a bluetooth speaker. Some sort of display and interface would be required to allow for the pairing of the device with bluetooth speakers and even other computers,