



LANDSCAPE-LEVEL CONSERVATION PLANNING FOR HAWAII'S SMALL-SCALE FARM GROUPS

Submitted in partial fulfillment of:
USDA-NRCS Conservation Innovative Grant
NRCS#69-3A75-11-212

June 15, 2015

Prepared by:

Thomas W. Esgate
Certified Conservation Planner
twesgate@sbcglobal.net
530-310-0146

Eileen Ilano, Ecological Consultant
eileenvcarey@yahoo.com
(916) 761-1535

Samir El-Swaify,
Emeritus Professor
Department of Natural Resources and Environmental Management
College of Tropical Agriculture and Human Resources
University of Hawai'i at Manoa
elswaify@hawaii.edu
(808) 277-2598

This material is based upon work supported by the Natural Resources Conservation Service, U.S. Department of Agriculture, under Conservation Innovative Grant # NRCS#69-3A75-11-212. Any opinions, findings, conclusions, or recommendations expressed in this publication are those of the author(s) and do not necessarily reflect the views of the U.S. Department of Agriculture.

Table of Contents

Introduction	1
What is a Conservation Plan	2
Benefits of Conservation Plans	3
Setting the Stage for Landscape-Level Planning	4
The Nine Step NRCS Planning Process	4
Step 1: Identify Problems and Opportunities	6
Step 2: Determine Objectives	7
Step 3: Inventory Resources	8
Step 4: Analyze Data	9
Step 5: Formulate Alternatives	10
Step 6: Evaluate Alternatives	10
Step 7: Make Decisions	11
Step 8: Implement the Plan	14
Step 9: Evaluate the Plan	14
Tips for Small-Scale Producers	15
References	16
Photo Credits	17
Appendix 1: Abbreviated Individual Plot Plan	18

Guide to Landscape-Level Conservation Planning for Producer Groups



Healthy Hawaiian Watersheds Through Landscape-Level Planning

LANDSCAPE-LEVEL CONSERVATION PLANNING MAKES SENSE FOR HAWAII'S SMALL-SCALE FARMERS AND NATURAL RESOURCES. Small-scale farming in Hawai'i is on the rise. Farmers are producing food to feed their families, to meet the increasing demand for locally and sustainably grown agricultural products, and to move the Islands, which import between 60-70% of fresh fruits and vegetables alone, toward food self-sufficiency.

scale farms in Hawai'i are part of larger agricultural units, cooperatives, land trusts, or parks whose natural resources are best managed as a holistic unit.

Conservation plans developed for these larger units can be used by individual farmers, who own or lease land, to identify and implement practices that address resource concerns that can be most effectively addressed across multiple ownerships. This handbook provides an overview of conservation plans, the conservation planning process, and shows how planning at the landscape scale can save time and money and result in more effective conservation planning.



Landscape-level conservation planning protects Hawai'i's natural resources.

A CONSERVATION PLAN IS A ROADMAP TO MANAGING AN AREA'S NATURAL RESOURCES. Conservation plans are developed by individuals or groups, with help from the United States Department of Agriculture (USDA) Natural Resources Conservation Service (NRCS) and Soil and Water Conservation Districts (SWCDs), to manage the natural resources on farms or ranches. A conservation plan takes into account the unique: natural, human, and capital resources of the farm or ranch; resource concerns; opportunities for resource protection and enhancement; and most importantly, the objectives for management of farm or ranch resources. By taking all of these factors into account, a conservation plan strategically identifies and prioritizes the conservation practices that will best address an area's resource concerns and objectives.

Small-scale farms are important contributors to the growing demand for Hawaiian agricultural products. Small farming and ranching operations often require the same degree of conservation planning as larger farms to comply with local grading and grubbing ordinances and to access conservation funding. Many small-

THERE ARE MANY BENEFITS TO HAVING A CONSERVATION PLAN. Conservation plans take into account each farm's or ranch's resources and allow groups or individuals to manage the land's resources in the best possible way while maintaining productivity and sustainability for future generations. The greatest benefit of implementing a conservation plan is that conservation practices work best together and the beneficial effects of using multiple practices are generally additive. Using several practices to solve multiple problems is called the "systems approach" to conservation and promotes healthier agroecosystems and adjacent natural ecosystems.



Minimizing soil erosion through contour farming is even more effective when crop residues or mulches are used to: protect the soil surface from raindrop erosion, add nutrients to the soil, improve soil moisture, and smother weeds.

A LANDSCAPE-LEVEL CONSERVATION PLAN IDENTIFIES RESOURCE CONCERNS THAT CAN BE ADDRESSED MORE EFFECTIVELY BY IMPLEMENTING CONSERVATION PRACTICES ACROSS MULTIPLE OWNERSHIPS. It is not intended to be a substitute for planning at the individual farm plot level. In order for landscape-level planning to be effective there must be some continuity between farm plot ownerships, such as a cooperative or a single prime ownership that has lessees at the farm plot level.

LANDSCAPE-LEVEL PLANNING THAT COVERS MULTIPLE SMALL FARMS HAS ADDITIONAL BENEFITS.

LANDSCAPE-LEVEL CONSERVATION PLANNING USES PLANNING RESOURCES MORE EFFICIENTLY.

A growing number of small farms on the Islands means a growing demand for help with conservation planning. However, NRCS and SWCD staffs are limited. Small-scale producers in close proximity to each other are working with a very similar natural

Additional benefits of conservation planning are that farmers can:

- Receive technical assistance with planning from the NRCS or SWCDs at no cost
- Qualify for county grading, grubbing and stockpiling permit exemptions
- Become familiar with government regulations and receive guidance on how to prevent violations
- Qualify, in some cases, for USDA conservation programs to help implement conservation measures

Landscape-level conservation plans do not serve as conservation plans for individual small farm plots. In the case of producers within the Counties of Hawaii, individual plot-specific conservation plans still need to be developed, and then approved by the appropriate SWCD for the producer to benefit from a waiver to acquiring a county grading and grubbing permit for implementing conservation practices. A landscape-level conservation plan only identifies conservation practices to address the resource concerns; individual producers adopt the practices in their individual plot-specific conservation plans, along with other practices suited for their individual farms.

resource base and are likely to share the same resource concerns and goals for their operations. By focusing on the common needs and concerns of small-scale producers, landscape-level planning facilitated by NRCS and SWCDs planning staff is more practical for addressing certain resource concerns than can be done at the individual plot level and can better serve a greater number of Hawaii's small-scale farmers.

LANDSCAPE-LEVEL CONSERVATION PLANNING MAKES IT EASIER FOR SMALL-SCALE FARMERS TO DEVELOP CONSERVATION PLANS FOR THEIR FARMS WITHIN THE PLANNING AREA. A landscape-level conservation plan developed using NRCS guidelines contains information that a small-scale farmer needs to complete critical conservation practices that may be more effective, or only effective, if implemented on a landscape scale.

LANDSCAPE-LEVEL CONSERVATION PLANNING MULTIPLIES THE BENEFITS OF CONSERVATION PLANNING FOR INDIVIDUAL FARMS AND FOR HAWAII'S NATURAL RESOURCES. Just as conservation practices work best when implemented together as part of a conservation plan, they work best when applied over a large area or watershed; *and the larger the area covered by the plan, the more effective the practices will be.* Conservation measures implemented across the landscape also increase the effectiveness of practices implemented on individual small farms.



A grassed waterway used to stop gully formation on an individual farm will be more effective and less likely to wash out if it is part of an area-wide effort within a drainage to absorb more rainfall and reduce runoff.



An important feature of effective conservation is to encourage multiple adjacent farms within a "hydrologic" land unit to work together toward achieving their common goals. While this concept is now considered innovative, it is similar to the approach practiced by Ancient Hawaiians in the traditional Ahupua'a system of land management.

Ancient Hawaiians applied a systems approach to natural resource and watershed management. Ahupua'a were managed to maintain sustainable supplies of clean water, food, forest products, habitat for native species, and agricultural crops. Increasing development of the Islands and a move away from managing Ahupua'a (or watersheds) to maintain a sustainable lifestyle has led to many of the natural resource problems we see in Hawaii today from loss of native flora and fauna to pollution of fresh and ocean waters. By returning to managing agricultural land as part of the watersheds they belong to, we can learn from the Ahupua'a system and preserve Hawaii's natural resources for future generations.

SETTING THE STAGE FOR LANDSCAPE-LEVEL PLANNING

Currently NRCS does not have a Conservation Planning process for addressing resource concerns across multiple producer operations in one process. This manual sets forth a process for the development of a Landscape Scale Plan with the goal of reducing NRCS workloads in the development of site specific Conservation Plans in situations where all producers within a defined area are committed to the operation of their farms under a Conservation Plan.

Whether a plan is developed by an individual landowner or a group such as a cooperative, agricultural park, land trust, or community it is essential to know who the decision maker is. The **decision maker** is the individual, group, unit of government, or other entity that has the authority to make decisions regarding land use and implement the conservation plan. In an informal group, the decision maker is the group that has been given the authority to make decisions and implement the plan. For a formal group, such a cooperative or trust, the decision-maker is generally the owner or a board of elected or appointed officials. No matter who the decision maker is all collaborators must support the decisions made in a conservation plan for it to be effective. Although all participants may not agree 100% with all aspects of the decision, all participants must support the whole decision 100%.

With respect to conservation plan implementation, where land is under a single ownership, but small farm plots are leased to others, the owner can ensure conservation practices are followed through terms in their lease agreements. Where producers are members of a cooperative or other formal organization, it is the organization's responsibility to ensure conservation practices are followed and enforcement is most often achieved through terms set forth in the group's charter or by laws. Individual plot owners or lessees are ultimately accountable for implementing identified conservation practices, regardless of the overlying ownership or group membership.

LANDSCAPE-LEVEL CONSERVATION PLANNING USES THE NRCS PLANNING PROCESS. The NRCS Conservation Planning Process is a 9-step process divided into three phases. The three phases of planning take an individual or group from problems to practices to solutions. This handbook goes through the planning process step by step to show how landscape-level planning works and how individual farm plans fit in (Table 1).



PHASE I identifies problems and opportunities at the landscape scale, evaluates the current condition of the land, and sets objectives for the desired future condition. This phase is made up of four steps. These are described below with examples of similarities and differences between landscape-level and individual farm plans.

TABLE 1: SUMMARY OF THE NRCS PLANNING PROCESS FOR LANDSCAPE- LEVEL PLANS AND INDIVIDUAL PLOT PLANS WITHIN THE SAME PLANNING AREA.

PHASE OF THE PLANNING PROCESS	NINE STEP NRCS PLANNING PROCESS	LANDSCAPE-LEVEL PLAN	INDIVIDUAL PLOT PLANS
PHASE I	Identify Problems and Opportunities	Considers the planning area as a continuous unit without limitations imposed by land divisions.	Finer scale of individual small-scale operation.
	Determine Objectives	Made by the decision maker. Fully supported by all participants.	Within the framework of the landscape plan objectives, individuals can determine objectives specific to their operations.
	Inventory Resources	Landscape scale	Completed at the landscape scale. May address data relevant to the specific farm or ranch (such as equipment, capital, etc.), as appropriate.
	Analyze Data	Landscape scale	Completed at the landscape scale. May address data relevant to the specific farm or ranch (such as equipment, capital, etc.), as appropriate.
PHASE II	Formulate Alternatives	At the landscape scale without influence of boundaries for individual farming units. Based on objectives for resource management and common land uses and land use characteristics.	Based on objectives of individual and the human and capital resources available; practices considered for evaluation must be within the limits set by the larger plan. The alternatives considered by an individual farmer may include only a subset of those developed at the landscape level.
	Evaluate Alternatives	Consider what best meets group's shared objectives.	Within the framework of landscape plan, consider what best meets small-scale farmer's needs, resources, and schedule.
	Make Decisions	Choose what best meets group's shared objectives. Suites of practices based on land characteristics, plan objectives and any planning constraints. <i>Where applicable:</i> Choose practices to be implemented at landscape scale. Conservation map for planning area with area-wide practices and implementation schedule.	Choose what best meets small-scale farmer's needs, resources, and schedule. Conservation plan map for farm including schedule, individual practices.
PHASE III	Implement the Plan	Implement area-wide decisions in common areas. Complete plan implemented when individual farm plans are implemented.	Implement conservation practices specific to small-scale operation.
	Evaluate the Plan	Need follow-up to determine if the plan is working. If not, adapt practices.	Need follow-up to determine if the plan is working. If not, adapt practices.

Step 1. Identify Problems and Opportunities

The first step in identifying problems and opportunities is to survey the planning area. Planners bring a map or draw a map of the property showing fields, buildings, roads, streams, uncultivated areas, and other features. They take notes and identify resource concerns on the map. It is also important to look beyond the boundaries of the planning area for opportunities to complement management of these areas.



A Landscape-Level Plan looks at the whole planning area as a continuous unit without limitations imposed by land divisions. Individual Plot Plans will be limited in area although small-scale farmers will consider the interaction of their management actions with neighboring properties. When the land has been surveyed a list of the problems to solve with conservation practices is prepared. For example:

LANDSCAPE-LEVEL PLAN	INDIVIDUAL PLOT PLAN
Are banks of seasonal or perennial watercourses stable?	Same as Landscape-Level Plan
Are gullies forming in cultivated fields?	Same as Landscape-Level Plan
Are invasive weeds a problem?	Same as Landscape-Level Plan
Are there opportunities to obtain area wide funding to implement conservation practices?	Same as Landscape-Level Plan
Is runoff from the planning area into waterways muddy? Is it carrying excess nutrients from fertilizer or animal waste?	Is runoff emanating on-plot muddy? Is it carrying excess nutrients from fertilizer or animal waste?
Is runoff from the property negatively impacting adjacent landowners	Is runoff from the farm plot negatively impacting on-plot or adjacent landowners?
Is the vegetation in common areas healthy and productive?	Is on-plot vegetation healthy and productive?
Are common area road surfaces in good condition or are areas washed out?	How will run off from the common road be accommodated on the small farm plot? How will runoff from the on-plot road be dealt with?
Are there opportunities to partner with adjacent conservation land?	Are there opportunities to partner with adjacent properties?
Is there habitat for threatened or endangered plants or animals?	Identified in the Landscape-Level Plan. Will on-plot activities have an effect?
Are cultural resources present?	Identified in the Landscape-Level Plan more efficiently. Will on-plot activities have an effect?

Step 2. Determine Objectives

During Step 2, the decision maker identifies the objectives of the plan. Objectives take into account a variety of factors including: the group's or small-scale farmer's needs and values, resource conditions, business goals, land control (lease, own, rent), farm organization (e.g., cooperative, partnership, sole-proprietor), financial constraints, and legal constraints (e.g., endangered species act, cultural resources, covenants). Objectives may need to be revised and modified as new information is learned later in the inventory and analysis steps.



Objectives for a Landscape-Level Plan are made by the decision maker and supported by all participants. Individual small-scale operators can determine objectives for their operations; however, these must fall within the boundaries of the objectives for the Landscape-Level Plan.

Most conservation plans share the overall objectives of increasing agricultural productivity, reducing soil erosion, improving water quality, and identifying the best practices for the land. Depending on the decision maker, location of the property, or unique characteristics of the property, additional objectives might include:

LANDSCAPE-LEVEL PLAN	INDIVIDUAL PLOT PLAN
Make the community more food self-sufficient	Produce enough vegetables to feed a family and sell at weekend farmer's market
Identify areas where a riparian buffer may be beneficial	Install a riparian buffer
Establish an objective to improve wildlife habitat or habitat for a specific species	Improve wildlife habitat or habitat for a specific species
Establish an objective to transition to organic farming methods	Adopt practices for transitioning to organic farming methods
Establish an objective to implement traditional Hawaiian farming methods to the greatest extent possible	Implement traditional Hawaiian farming methods to the greatest extent possible
	Establish a sustainable permaculture operation

Step 3. Inventory Resources

At this step in the planning process a complete inventory of natural resources (soil, water, air, plants, and animals) is completed at the landscape scale. Economic and social considerations (e.g., structures, equipment, capital, labor, management, profitability, public health and safety) and special environmental concerns (e.g., potential to impact coral reefs; presence of threatened and endangered species; prime and unique farmlands; riparian areas) within the planning area are also evaluated. The NRCS Environmental Evaluation Worksheet (NRCS CPA-52) should be used at this step to analyze and record the existing, or benchmark, conditions for each identified concern. Resource Concerns and Environmental Concerns Factsheets are helpful in identifying and further refining problems, objectives, and appropriate practices to include in Step 5, Formulating Alternatives. It is important that as much information as possible can be collected so that the plan will fit both the needs of the landowner and the natural resources.

Information collected at this stage, and analyzed in the next, will be used throughout the entire process to define alternatives and to evaluate the effectiveness of the conservation plan at achieving your goals.

All resources are inventoried at the landscape scale. No additional inventory is needed for Individual Plot Plans with respect to natural resources or special environmental concerns. Supplemental economic and social data for individual plot plans may include equipment, other capital, and labor.

Basic Hawaii Pasture Condition Score Sheet

Ranch name: Aloha Pastures Pasture name/#: Transect 1 Conservation Plan Field 12

Current year's rainfall: Above normal Normal Below Normal Date: June 7, 2013

Evaluate the site and rate each indicator based upon your observations. Scores for each indicator may range from 1 to 5. Multiply the points x the weight to get weighted points. Sum the weighted points to determine overall pasture condition score.

Indicators	1 point	3 points	5 points	Enter Score (points)	Weight	Wtd. points
1. Percent desirable plants	Desirable species <20% of stand. Weeds and/or woody non-desirable invasives are dominant.	Desirable species 40-60% of stand. Weeds and non-desirable weedy grasses invading.	Desirable species exceed 80% of plant community.	4	2	8
2. Live plant cover	Desirable forage canopy cover is <30%. Very little plant cover to slow or stop runoff.	Desirable forage canopy cover is 50-80%. Most forages are grazed close to the ground.				
3. Plant diversity (Estimate as a grazing system)	One dominant forage species is present. Plants are not evenly grazed; animals are poorly distributed.	Two to three forage species present from one dominant functional group (grass, legume, etc.).				
4. Plant residue (Dead organic material covering soil between tillers or stems)	No dead leaves or stems present on soil surface.	30-50% of the ground is covered with dead leaves or stems. Where sod forming grasses are dominant, the average mat thickness is 2-3 inches.				
5. Plant vigor	There is no recovery after grazing. More than 80% of plants are pale yellow or brown or permanently wilted or lost due to insects or disease.	Recovery after grazing takes weeks longer than normal or urine/dung patches are dark green in contrast to the rest of the plants, or there is minor insect or disease loss or mild plant wilting.				

NRCS-CPA-52, April 2013

A variety of resource inventory tools and methods are used in Step 3

Step 4. Analyze Data

Data collected in Step 3 will be analyzed at the landscape level to clearly define existing conditions for all of the natural resources, including limitations and potential for the desired use. This step is key to developing plans that will work for a landowner and their land. It also provides a clear understanding of the baseline conditions that will be used to judge how effective a project is after it has been put into place.

The soil resource report is an important tool for identifying limitations and potential of the land for desired uses. By using the soils map, and accompanying map unit descriptions, planners can separate the landscape into segments, or Conservation Management Units (CMUs), that have similar use and management requirements. Soil capability class can be used to partition the planning area into (1) lands suitable for crops or (2) lands suitable for pasture, rangeland, forestland, or wildlife. Within these two divisions of land use, slope and hydrologic soil group (which indicates potential for runoff from the soil when thoroughly wet) could be used to further subdivide the area.

Other important resources in identifying limitations and potential of the land for desired uses include: presence of seasonal or perennial streams, habitat for Threatened and Endangered Species, and presence of cultural resources that need to be avoided. Additional areas that are not suitable for farming or ranching such as areas with very steep slopes, ephemeral gullies or gulches, and exposed stream banks should also be identified. Conservation practices suitable for small farming and ranching operations will be identified for remaining areas in Step 5.

All data are analyzed at the landscape scale. No additional analysis is necessary for natural resources or special environmental concerns. Analysis of economic and social data for individual plot plans may address information relevant to the specific farm or ranch (such as equipment, labor, etc.).

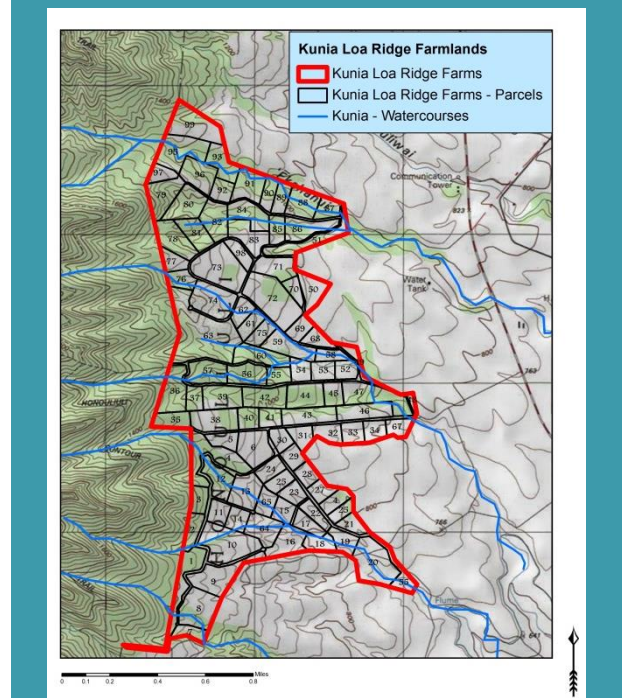
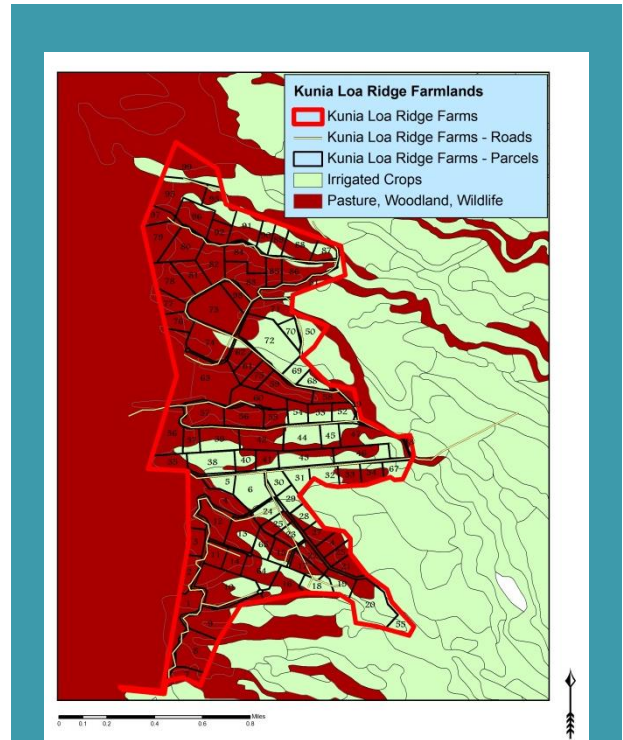

Maps of soil suitability class (top) and perennial watercourses (bottom) are useful for identifying suitable land uses.

PHASE II identifies, evaluates, and chooses conservation practices to achieve the plan’s objectives. This phase is made up of three steps. These steps are described below with examples of similarities and differences between landscape-level and individual farm plans.

Step 5. Formulate Alternatives

In Step 5 alternative scenarios for meeting the objectives of the plan are developed. Conservation practices are chosen for consideration in the plan only if they are appropriate for the landscape and they reflect the rules, regulations, and objectives applying to the larger group.

At this step, a comprehensive list of conservation practices to address specific resource concerns within the common management units (identified in Steps 2 and 3) will be compiled. Practices that the group does not want to implement or that do not meet any restrictions placed on the land by the defined objectives or other constraints will be screened out (e.g., if ranching is not allowed within the planning area the alternatives will not include conservation practices related to livestock management). The alternatives considered by an individual farmer may include only a subset of those developed at the landscape level.

In some instances, resource concerns at the landscape scale will dictate mandatory conservation practices. For example, planning-area-wide erosion of stream banks, gullies, and gulches may necessitate the installation of grassed waterways on impacted plots. Choosing among a suite of mandatory practices may also be an option (e.g., in vegetating a sensitive riparian area, farmers may be able to choose between implementing a riparian forest buffer or a contour orchard).

In other cases, resource concerns at the landscape scale will identify the need for practices to be implemented as part of the Landscape-Level Plan. (e.g., projects addressing the larger area, such as sediment control basins, that are beyond the logistical and financial capability of individual small-scale producers). Implementation of conservation practices at the landscape level would also be necessary in the event that the larger group (such as a cooperative or trust) provides common conservation protection or services.

Step 6. Evaluate Alternatives

Step 6 is to evaluate the alternatives to determine their effectiveness in addressing the problems, opportunities and objectives for the planning area. Attention must be given to those ecological values protected by law or executive order that were evaluated under Step 3 as Special Environmental Concerns.

At the landscape level consideration is given to what best meets group’s shared objectives. At the individual plot level consideration is given to what best meets the small-scale farmer’s needs, resources, and schedule while meeting any requirements for the Landscape-Level Plan (e.g., mandatory conservation practices).



Step 7. Make Decisions

At this step the decision maker will identify suites of conservation practices that are suitable to address resource concerns in Individual Plot Plans. These practices will be based on land characteristics (e.g., practices for crops versus pasture or gentle versus steep slopes) as well as the objectives and any planning constraints. For Individual Plot Plans, small-scale farmers choose the combination of practices from the suite of practices identified in the Landscape-Level Plan that best meets their needs, resources, and schedules. Where applicable, the decision maker will also choose practices to be implemented at the landscape scale.

The completed conservation plan serves as a written record of management decisions and the conservation practices that will be implemented in common areas and recommended for individual plots. Table 2 compares the parts of a conservation plan for a Landscape-Level Plan and Individual Plot Plans. A conservation plan includes:

1. Decision Maker's Objectives
2. An aerial photo or diagram of the planning area. An aerial photo makes it easy to locate individual plots or fields and to see how these fit into and are affected by the surrounding landscape.
3. A map of the soils within the planning area and descriptions of these soils. Soils are the foundation of agriculture. The soil survey is an excellent source of information for determining appropriate lands uses and conservation practices.
4. Information on grasses, trees, and broad-leafed plants that grow within the planning area. Small-scale farmers will need to be familiar with those present on their plot.
5. Resource inventory data which can include crop production potential, engineering designs and support data, and potential livestock and wildlife carrying capacity. This inventory provides a snapshot of the resource conditions prior to implementing a conservation plan, and therefore, can be used in the future to evaluate the effectiveness of the conservation plan.
6. The location and schedule for applying conservation practices and systems – where and when specific practices will be applied. This will reflect balancing objectives with resource concerns and human and capital resource availability.

In a landscape-level plan the location of mandatory and suggested conservation practices will be mapped but implementation scheduling will be included in individual plot plans. If area-wide practices will be implemented by the controlling authority, the landscape-level plan will also include a conservation plan map for the planning area with area-wide practices identified and an implementation schedule.

Individual plot plans will include a conservation plan map for the farm plot with individual practices identified (including mandatory practices, if applicable) and an implementation schedule.

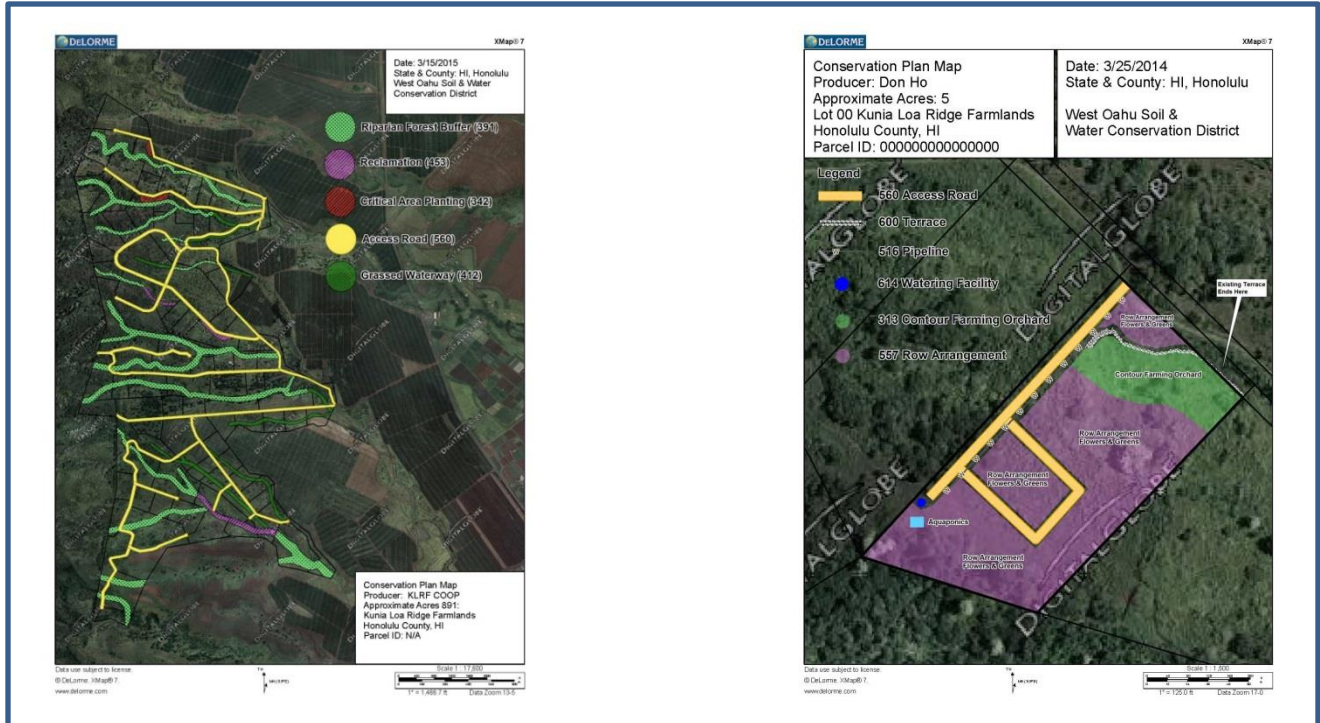

Conservation plan maps for a Landscape-Level (left) and Individual Plot (right) Plan. The location of mandatory and suggested conservation practices are shown on the landscape-level plan map. The individual plot map includes practices that will be implemented on the small farm plot.

The following two components are found in individual plot plans but are only included in landscape-level plans when practices are implemented in common areas by the controlling authority.

1. A plan of operation and maintenance for conservation systems of practices. Templates for Operations and Maintenance Plans for conservation practices requiring these can be found in the Pacific Islands Area Field Office Technical Guide (FOTG) available at <http://efotg.sc.egov.usda.gov/>.
2. Job sheets (for applicable practices) and Fact sheets. Job sheets can be found in the Pacific Islands Area FOTG. Fact sheets for relevant resource concerns and practices can be found at the NRCS website: <http://www.nrcs.usda.gov/>.

Individual Plot Plans will likely go through a vetting or approval process at the cooperative or lessor level. The plan should be taken to the appropriate SWCD if the plot operator wishes to take advantage of a waiver from the county grading and grubbing permit process. Note: there may be activities that are of such a scale or intensity, or outside the realm of a conservation plan, that a county permit may still be required. With regard to state and county regulations, Soil and Water Conservation Districts are the sole authority for approving conservation plans in the State of Hawai'i. An abbreviated sample Individual Plot Plan is provided in Appendix 1; parts 2-5 of the Landscape-Level Plan (above) are omitted for simplicity.



TABLE 2: CONSERVATION PLAN COMPONENTS FOR INDIVIDUAL AND LANDSCAPE-LEVEL PLANNING.

PART OF CONSERVATION PLAN	LANDSCAPE-LEVEL PLAN	INDIVIDUAL PLOT PLAN
Decision Maker's Objectives	Landscape scale	Landscape Scale; may have additional objectives within the framework of those for Landscape Plan
An aerial photo or diagram of the planning area	Landscape scale	From Landscape-Level Plan
A map of the soils within the planning area and descriptions of these soils	Landscape scale	From Landscape-Level Plan
Information on grasses, trees, and broad-leafed plants that grow within the planning area	Landscape scale	From Landscape-Level Plan
Resource inventory data which can include crop production potential, engineering designs and support data, and potential livestock and wildlife carrying capacity	Landscape scale	From Landscape-Level Plan and further refined, as appropriate, for smaller unit
The location and schedule for applying conservation practices	Suites of conservation practices that are appropriate for objectives, constraints, and land capability will be identified but not mapped to individual plots. Mandatory practices will be mapped. Some practices may be implemented in common areas by the controlling authority. Location and schedule of practices to be implemented at the landscape scale will be mapped and scheduled.	Conservation plan map (either drawn or overlaid on an aerial photo) and schedule with individual practices delineated. Practices chosen will be a subset of those identified in the Landscape-Level Plan.
A plan of operation and maintenance for conservation systems of practices	If practices are implemented in common areas by the controlling authority	For individual plan
Job sheets and fact sheets	If practices are implemented in common areas by the controlling authority	Included with each plot plan for small-scale producer's reference

PHASE III implements the plan, evaluates its effectiveness, and adapts practices as needed. This phase is made up of two steps. These are described below with examples of similarities and differences between landscape-level and individual farm plans.

Step 8. Implement the Plan

At this stage individual farmers will implement the conservation practices specific to their small-scale operation. The Landscape-Level Plan will implement any area-wide decisions (e.g., roads, conservation buffers, other large improvements). Implementation of the Landscape-Level Plan will be complete when individual farm plans are in place.

For individual producers, NRCS can provide technical assistance to help with the installation of adequate and properly-designed conservation practices. NRCS can also provide assistance to individual producers in obtaining permits, land rights, surveys, final designs, and inspections for structural practices.



Step 9. Evaluate the Plan

Conservation planning is an ongoing process that continues long after the implementation of conservation practices. By evaluating the effectiveness of a conservation plan or a practice within a plan, stakeholders can keep or adopt new practices as necessary to achieve plan objectives.

TIPS FOR SMALL-SCALE PRODUCERS

If you are a small-scale farmer considering leasing land where a conservation plan has already been approved it is important to understand how a Landscape-Level Plan can affect your farming operations. Keep in mind that:

- It is important for all farmers to know the objectives of the plan prior to beginning farm operations. Farmers who cannot fully support these objectives should choose another area to farm.
- Ask to see the conservation plan. What areas are available for your farming activities? Do any of these areas meet the criteria you have identified for your needs? Prospective farmers must make sure that the land available for use meets their individual objectives. For example, if only land suitable for tree crops is available, a farmer planning on growing vegetables would be advised to find another location to farm.
- Examine the plan map and locate your prospective parcel. What conservation practices have been prescribed for a parcel of this type? Can you commit to implementing conservation practices within the suite that have been prescribed to meet the objectives of the Landscape-Level Plan for the land that you will be farming? If not, it would be best to find another location for your operation.
- If the site meets your needs, the majority of conservation planning has been completed. All that you will need to do is to choose from the conservation practices that are approved for your parcel to create a plan for the parcel of land that you will be farming.

State of Hawai'i Department of Land and Natural Resources. 2015. Soil and Water Conservation District Program: Conservation Planning. Available at: <http://dlnr.hawaii.gov/swcd/conservation-planning/>

O'ahu Resource Conservation and Development Council (ORCDC). 2013. Watershed Based Management Plan for Honouliuli Watershed: A Guide for Erosion and Sediment Control on Agricultural and Forest Reserve Lands. 135pp. Available at: <http://health.hawaii.gov/cwb/files/2013/05/Watershed-Plan.pdf>

Smith, Jody and Samir A. El-Swaify. (eds.) 2006. Toward Sustainable Agriculture. A Guide for Hawai'i's Farmers. College of Tropical Agriculture and Human Resources, University of Hawai'i at Mānoa. 65 pp. Available at: http://www.ctahr.hawaii.edu/oc/freepubs/pdf/TSA_guide.pdf.

United States Department of Agriculture (USDA) Natural Resources Conservation Service (NRCS). 2014. NRCS PLANNING MANUAL - Part 600 – National Planning Procedures Handbook. 205pp. Available at: <http://directives.sc.egov.usda.gov/ViewerFS.aspx?hid=33232>

USDA NRCS. The Nine-Step Conservation Planning Process. Available at: http://www.nrcs.usda.gov/wps/portal/nrcs/detail/nh/technical/cp/?cid=nrcs144p2_015695

USDA NRCS. Conservation Planning. Productive lands, healthy environment. 2pp. Available at: <http://www.nrcs.usda.gov/wps/portal/nrcs/detail/national/programs/technical/cta/?cid=stelprdb1049425>.

USDA NRCS. Pacific Islands Area Field Office Technical Guide (FOTG). Available at: <http://efotg.sc.egov.usda.gov/>.

USDA NRCS South East Region. Small Scale Small Field Conservation. Simple practices and concepts to help you solve natural resource problems with a small investment of time and money. 19 pp. Available at: http://www.nrcs.usda.gov/Internet/FSE_DOCUMENTS/nrcs141p2_015417.pdf

Photo Credits

Cover	Top left landscape	Thomas Esgate
Cover	Field Tour	Thomas Esgate
Cover	Right landscape	Eileen Carey
Page 1	Landscape	Thomas Esgate
Page 1	Steam and Fish	The Nature Conservancy
Page 1	Coral	NOAA
Page 1	Bird	Robin Kepple,
Page 2	Contour farming	Thomas Esgate
Page 3	Grassed waterway	Thomas Esgate
Page 3	Landscape	National Science Foundation
Page 4	Producer consultation	Thomas Esgate
Page 6	Landscape	Thomas Esgate
Page 7	Farm field day	Thomas Esgate
Page 8	Soil sampling	Eileen Carey
Page 8	Plant sample	Eileen Carey
Page 14	Installing grassed waterway	Thomas Esgate
Page 14	Producers	Thomas Esgate
Page 14	Evaluating grassed waterway	Eileen Carey

Appendix 1
Abbreviated Individual Plot Plan



West Oahu Soil and Water Conservation District
99-193 Aiea Heights Drive, Suite 109
Aiea, HI 96701



Cooperative Agreement

Farm Name: Happy Valley Farm

Cooperator's Name: Don Ho E-mail address: _____

Mailing Address: 123 Happy Valley RD, Happy Valley, HI 00000

Home Phone: 111-111-1111 Business Phone: _____ Fax: _____

Description of Project Area (attach map of area)

Location: _____ Tax Map Key _____ Acreage: _____ Zoning Designation: _____

Describe proposed agricultural activity. (Attach additional information, if necessary)

The Cooperator Agrees To:

1. Develop a conservation program for the project area as needed;
2. Maintain all appropriate conservation structures established in acceptable condition and to continue the use of all other conservation measures put into effect;
3. Be responsible for securing the required permits for work regulated by any other ordinance, code, or agency;
4. Refrain from starting any ground work or installing any conservation practices until a completed conservation plan is developed and approved by the District or before obtaining a grading/grubbing permit from the Honolulu City and County Department of Planning and Permitting;
5. Permit access to the District and Natural Resources Conservation Service to monitor work.
6. Develop a Grading plan where large scale filling and grading is involved.

The District Agrees To:

1. Provide information and technical assistance to prepare and implement a conservation plan.

It is Further Agreed That:

1. This agreement will become effective on the date approved and signed by the District Director, and may be terminated or modified by mutual agreement in writing of parties hereto; or by the violation of any provision of this agreement by the cooperator.
2. The provisions of this agreement are understood by the cooperator and the District. The District shall not be liable for damage to the other's property resulting from carrying out this agreement.
3. The District shall not be responsible or liable for any fines or punishment due to any violations of the cooperator.

Cooperator

Date

District

Date

Conservation Plan Map
 Producer: Don Ho
 Approximate Acres: 5
 Lot 00 Kunia Loa Ridge Farmlands
 Honolulu County, HI
 Parcel ID: 0000000000000000

Date: 3/25/2014
 State & County: HI, Honolulu
 West Oahu Soil &
 Water Conservation District

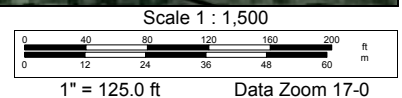

Conservation Plan

Don Ho
 123 Happy Valley Road
 Happy Valley, HI 00000

Lot 00, Kunia Loa Ridge Framlands
 Honolulu County, HI Unique Parcel ID:
000000000000
 Approximately 5.075 acres

OBJECTIVE(S)

Establish a sustainable Flower Farm with other tropical plants and orchard stock.

Field 1

Access Road (560)

To provide a fixed route for vehicular travel for resource activities involving the management of timber, livestock, agriculture, wildlife habitat, and other conservation enterprises while protecting the soil, water, air, fish, wildlife, and other adjacent natural resources.

Field	Planned Amount	Month	Year	Applied Amount	Date
1	1,081 ft	4	2014		
Total:	1,081 ft				

Terrace (600)

Stabilize earth embankment/ridge and channel, constructed across a field slope. practice is being applied as part of a resource management system in order to: 1) Reduce erosion by reducing slope length, and; 2). Retain runoff for moisture conservation.

Operation and Maintenance:

Periodic inspections and repairs will be performed in a timely manner as needed.

Field	Planned Amount	Month	Year	Applied Amount	Date
1	300 ft	4	2014		
Total:	300 ft				

Pipeline (516)

Convey water from a source of supply solely for irrigation purposes.

Field	Planned Amount	Month	Year	Applied Amount	Date
1	580 ft.	4	2014		
Total:	580 ft.				

Watering Facility (614)

To provide water irrigation purposes in order to:

- Meet daily irrigating requirements
- Improve animal distribution

Field	Planned Amount	Month	Year	Applied Amount	Date
1	1 ea.	5	2014		
Total:	1 ea.				

Contour Farming, Orchard (313)

To provide a fixed route for vehicular travel for resource activities involving the management of timber, livestock, agriculture, wildlife habitat, and other conservation enterprises while protecting the soil, water, air, fish, wildlife, and other adjacent natural resources

Field	Planned Amount	Month	Year	Applied Amount	Date
2	0.70 ac..	12	2014		
Total:	0.70 ac..				

Row Arrangement (557)

Establish crop rows in direction, grade and length to:

- Provide adequate drainage
- Provide erosion control
- Permit optimum use of rainfall and irrigation water

Field	Planned Amount	Month	Year	Applied Amount	Date
2	4.375 ac.	12	2015		
Total:	4.375 ac.				

CERTIFICATION OF PARTICIPANTS

_____	_____	_____
Don Ho	DATE	DATE

CERTIFICATION OF CONSERVATION DISTRICT:

_____	_____
West Oahu Soil & Water Conservation District	DATE

Access Roads on Pacific Island Farms

USDA NRCS Practice (560)



Rutted roads can damage farm vehicles making it necessary to repair and replace them often.

What is an access road?

Pacific Island farms need travel ways to move crops, livestock, supplies and equipment around the farm. A stable, long-lasting access road can be a major improvement for any farm business. An **access road** may vary from an unsurfaced trail with seasonal access to a year-round, all-weather surfaced roadway.

Why build and improve access roads?

Pacific Island farmers can benefit from stable access roads on their farm. Using this practice can:

- provide a safe, stable route for moving equipment, supplies, crops, and animals.
- reduce expensive long-term road maintenance and labor costs.
- improve farm appearance and quality of life.
- prevent erosion problems.
- keep water bodies clean.

Where are access roads used?

- In farm areas where vehicles must travel

Plan for access roads

Poor access roads can cause many problems for Pacific Island farmers. Rutted roads can damage farm vehicles making it necessary to repair and replace them often. If you are spending valuable time and money to repair sections of the road again and again after heavy rain storms, it may be worthwhile to invest in improving your access roads.

- Consider slopes when laying out roads. Plan and build roads across the slope and stay off steep slopes. Long sections of road going up and down the slope are difficult to drive and keep stable. Avoid them to save time and money on maintenance and repair.
- Consider soils when designing access roads. Learn about the soils your farm roads will cross. For example, heavy clay soils, rocky soils, and wet soils each have different construction considerations to build a durable, long lasting road.
- Consider stream crossings when planning your roads. As much as possible, avoid stream crossings because they are expensive to build and maintain. If they are not built properly, they can wash out, causing expensive damage to property, to water quality, and to fish and wildlife.

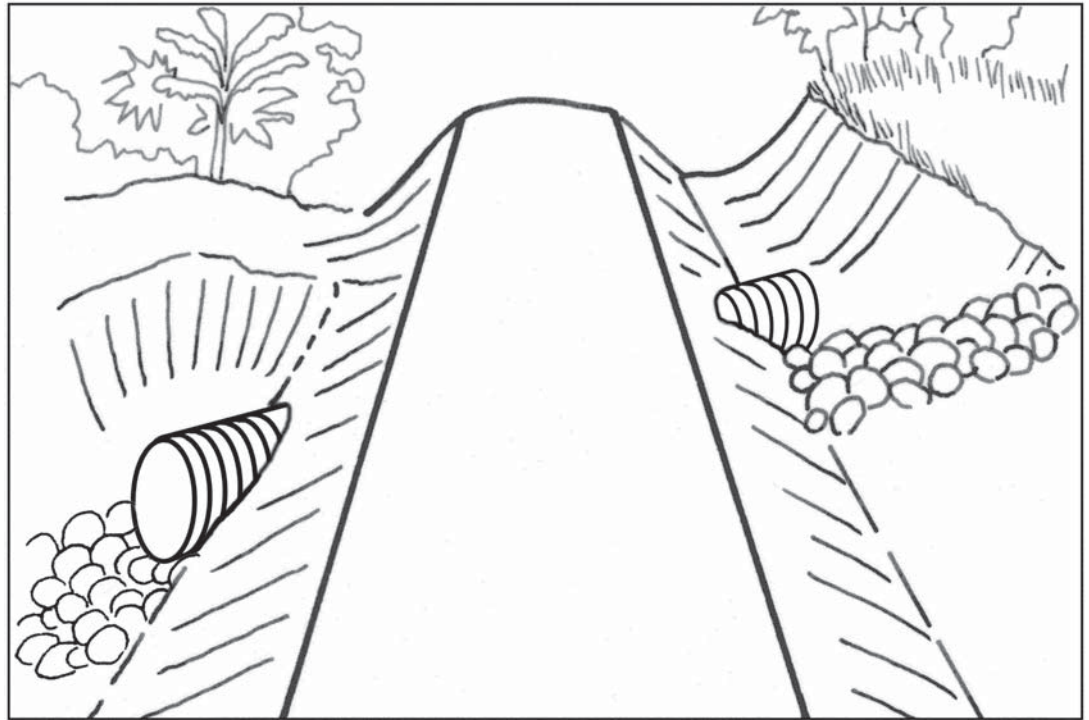

Roads that are safe to travel on have a good shape, a stable surface, good drainage, and stable side ditches.

Roads that are safe to travel on have a good shape, a stable surface, good drainage, and stable side ditches. A dry road surface provides safer driving conditions.

Road Shape: When surface water does not quickly drain off the road, it can lead to washouts, muddy conditions, and potholes. Build roads to drain off the water. Crown the center of the road by making the road higher in the middle and lower on the sides to allow water to quickly run off the road surface.

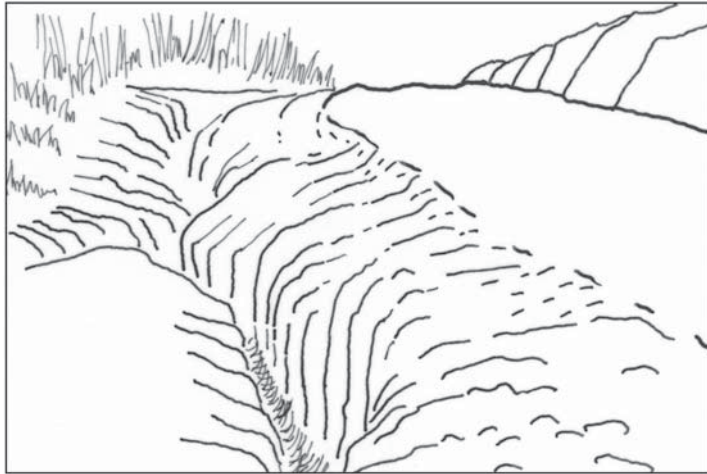

The shape of the ditch is important. Narrow V-shaped ditches take less space, but concentrate water into a small area and may cut down into the ground.

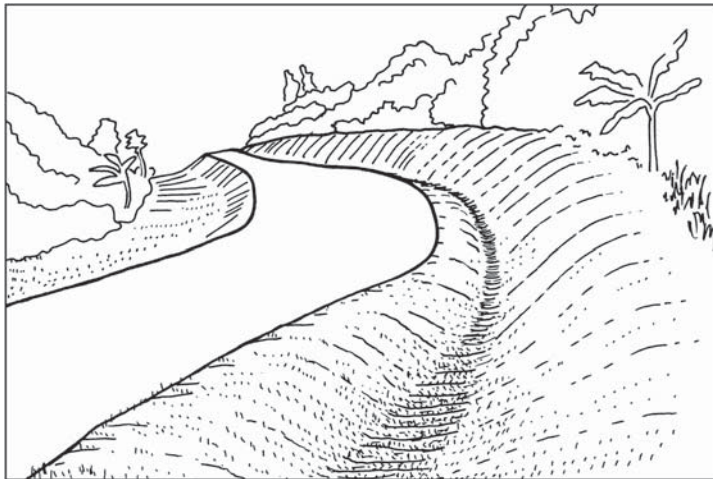

Wide flat ditches can spread water out and slow down its speed.

Road Drainage: If needed, use other conservation practices to help divert and drain water off the road surface. Water bars and broad based dips are like speed bumps built at an angle across the road. Use them to move water from the road surface to the road's edge. Open-top culverts are long, box-like channels cut down into the road surface to collect and divert water to the side.

Stable Roadside Ditches: Ditches collect road surface run-off and drain it away from the road. Poorly designed and built ditches can make a bad situation even worse. The shape of the ditch is important. Wide flat ditches can spread water out and slow down its speed. Narrow V-shaped ditches take less space, but concentrate water into a small area and may cut down into the ground. Adjust the shape of the ditch to spread out and slow down water. Don't make ditch side slopes too steep, which can cause erosion and maintenance problems. Discharge water collected from road ditches into natural undisturbed areas with thick plant growth. Some outlet areas may need strengthening with rock or stone.

If your road ditches carry large volumes of storm water, get help from a qualified professional to help design your ditches, culverts and outlets.

Culverts and Stable Outlets: Culverts carry water from one side of a road to the other. They are generally made from corrugated metal, plastic, or concrete. Culverts are used where roads cross drainage ways

(such as a stream or seasonal runoff channel) to keep natural flow patterns and protect wildlife. In other cases, some roads can act like a dam. If the road holds back large volumes of surface runoff, plan to install a culvert to let water get from one side to the other. In both cases, a well sized culvert will prevent your road from being washed out during big storms. Protect the downside end of the culvert from eroding with stone or a plunge pool.

Roads in wet areas: Often wet areas on the farm may be protected wetlands. Avoid building roads through them.

Surfaced roadways: Get help from a qualified professional to design and build surfaced roadways for heavy use.

For the best results, combine **access roads** with other conservation practices:

- **Heavy Use Area Protection (561):** strengthening heavily used areas with mulch, gravel, asphalt, concrete, cement

For assistance to plan, design or construct an access road, contact your local USDA NRCS field office.

Additional information is available from your local USDA Service Center or at www.pb.nrcs.usda.gov and www.hi.nrcs.usda.gov.

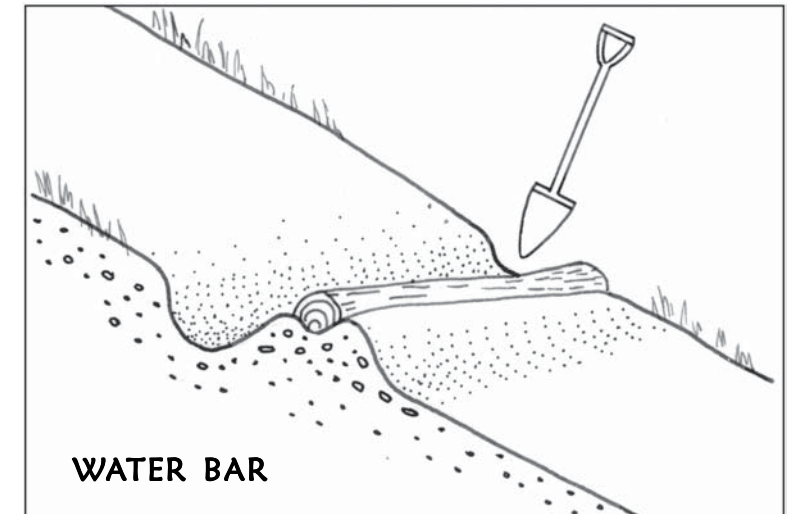
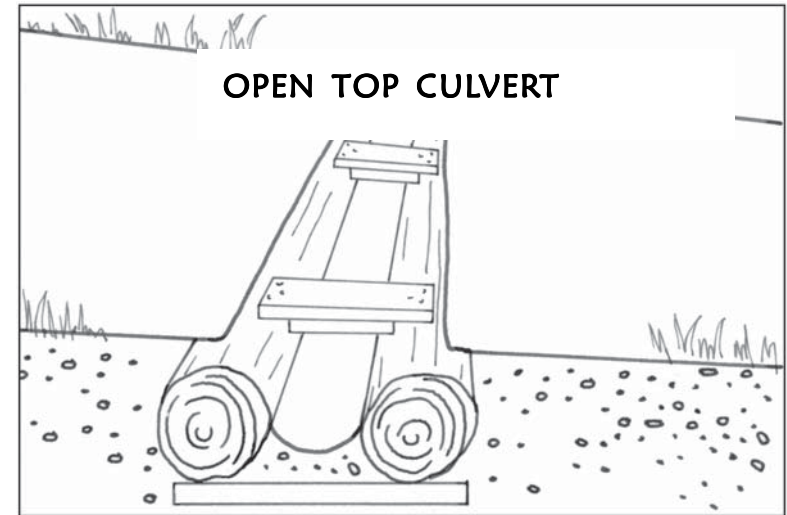

The United States Department of Agriculture (USDA) prohibits discrimination in its programs on the basis of race, color, national origin, sex, religion, age, disability, political beliefs and marital or familial status. (Not all prohibited bases apply to all programs.) Persons with disabilities who require alternative means for communication of program information (Braille, large print, audiotape, etc.) should contact the USDA Office of Communications at (202) 720 2791 To file a complaint, write the Secretary of Agriculture, U.S. Department of Agriculture, Washington, D.C. 20250, or call (800) 245-6340 (voice) or (202) 720-1127 (TDD). USDA is an equal employment opportunity employer. **Conservation System Guides for Pacific Basin Farmers and Ranchers** (fact sheets and PowerPoint programs) produced by the University of Hawaii, CTAHR NREM. Funding provided by USDA NRCS CIG Grant (Agreement No. 69-9251-5-682). Pl: Dr. Carl Evensen. Authors/Instructional Designers: L.F. Castro, J. Smith. Illustrator: N. Hulbirt.



**NATURAL RESOURCES CONSERVATION SERVICE
PACIFIC ISLANDS AREA
CONSERVATION PRACTICE SPECIFICATION
ACCESS ROAD (560)**

SCOPE

This specification covers the installation of access roads. Construction shall be in accordance with the construction drawings and these specifications.

SAFETY

Landowners or operators, sponsoring organizations, and contractors, shall be liable for damage to utilities and damage resulting from disruption of service caused by construction activities. The Natural Resources Conservation Service makes no representation on the existence or non-existence of any utilities. Absence of utilities on the drawings is not assurance that no utilities are present at the site.

It is the responsibility of the landowner or operator to determine if there are buried or overhead utilities in the vicinity of the proposed work. They should take proper procedures to insure that the utilities shall not be jeopardized and that equipment operators and others will not be injured during construction operations.

CONSTRUCTION OPERATIONS

Construction operations shall be carried out in such a manner and sequence that erosion and air and water pollution are minimized and held within legal limits.

The owner, operator, contractor or other persons will conduct all work and operations in accordance with proper safety codes for the type of construction being performed with due regards to the safety of all persons and property.

INSTALLATION

Site preparation. All trees, stumps, roots, brush, weeds, shoulders, ditches, and other objectionable material shall be removed from the areas required for the roadway, side road approaches, and inlet and outlet ditches. All unsuitable material shall be excavated from the roadbed areas.

Subgrade preparation. The roadbed shall be graded to the elevations shown on the plans for subgrade preparation. The subgrade and fill from borrow areas, if required, shall be compacted by controlled movement of the hauling and spreading equipment. The entire surface area shall be traversed by not less than one tread track of the loaded equipment or by not less than two passes of a pneumatic-tired roller capable of exerting a pressure of 75 pounds per square inch.

Drainage structures. Structures shall be installed to the lines and grades shown on the drawings. Corrugated metal culverts and other materials shall be of a quality that equals or exceeds the physical requirements shown on the plans.

Backfilling around culverts and abutments shall be accomplished by means of hand tamping, manually directed power tampers, or plate vibrators.

Sub-base. The sub-base course shall consist of crushed rock or gravel and shall be clean and reasonably well graded from fine to coarse. The maximum size shall be not greater than 1-1/2 inch. It shall be placed to the cross section shown on the drawings and be rolled with a smooth steel-wheeled roller.

Surface course. Placement of the surface course shall be in accordance with sound highway construction practice for the surface material used.

WORKMANSHIP

All construction shall be performed in a workmanlike manner, and the job site shall have a neat appearance when finished.

All disturbed areas not graveled or paved will be vegetated to control erosion.

BASIS OF ACCEPTANCE

The acceptability of this practice shall be determined by inspections during and following construction to ensure compliance with all provisions of this specification and the construction drawings.

**NATURAL RESOURCES CONSERVATION SERVICE
PACIFIC ISLANDS AREA**

CONSERVATION PRACTICE SPECIFICATION

TERRACE (600)

SCOPE

This specification covers the construction of terraces. Construction shall be in accordance with the drawings and these specifications.

SAFETY

Landowners or operators, sponsoring organizations, and contractors shall be liable for damage to utilities and damage resulting from disruption of service caused by construction activities. The Natural Resources Conservation Service makes no representation on the existence or nonexistence of any utilities. Absence of utilities on the drawings is not assurance that no utilities are present at the site.

It is the responsibility of the landowner or operator to determine if there are buried or overhead utilities in the vicinity of the proposed work. They will take proper procedures to insure that the utilities shall not be jeopardized and that equipment operators and others will not be injured during construction operations.

SITE PREPARATION

All dead furrows, ditches, or gullies to be crossed by the terrace shall be filled in before terrace construction begins in order to facilitate construction and to prevent seepage through the terrace ridge. Old terraces, fences, trees, or other obstructions that will interfere with the successful operation of the system shall be removed.

EARTH WORK

The terraces shall be constructed to the lines, grades, and cross sections shown on the plans and/or staked in the field. The minimum cross section shall meet or exceed design dimensions, and the channel shall drain reasonably well. The top of the constructed ridge shall not be lower at any point than the design elevation. The channel shall not be higher at any point than the design elevation. The slope shall not vary more than 0.30% from the design grade in any 100 foot section (e.g. A terrace designed for a 1% slope shall not be less than 0.70 % nor more than 1.30 % slope.).

Material for earthfill shall be obtained from excavation in the channel or other designated areas. It shall be free of objectionable materials such as brush, roots more than 1 inch in diameter, and rocks over 6 inches in diameter.

While it is generally always preferable, where it is necessary, topsoil is to be stockpiled and spread over excavations and other areas to facilitate restoration of productivity.

Earthfill shall be compacted by machinery travel. The maximum layer thickness before compaction shall be 4 inches. The tracks of the equipment must pass over 90 percent of the surface of each lift before a new lift is placed. The moisture content of the terrace fill material shall be such that, when kneaded in the hand, the fill material will form a ball that does not readily separate. Material that is too wet shall be dried and material that is too dry shall have water added or work shall be stopped until moisture conditions are satisfactory.

Terrace ridges constructed across gullies or depressions shall be compacted by machinery travel or other means sufficient to insure proper functioning of the terrace.

Any ditch or depression at the bottom of the back slope shall be filled and smoothed so that drainage will be away from the terrace and not parallel to it.

The surface of the finished terrace shall be reasonably smooth and present a workmanlike finish.

OUTLETS

The outlet shall be equal in area to the channel capacity requirements. The outlet of the terrace shall be stable and every effort shall be made to protect the terrace outlet. If a vegetated outlet is already established, the heavy equipment movement in the outlet during terrace construction shall be closely controlled.

WORKMANSHIP

All construction shall be performed in a workmanlike manner, and the job site shall have a neat appearance when finished.

CONSTRUCTION OPERATIONS

Construction operations shall be carried out in such a manner and sequence that erosion and air and water pollution are minimized and held within legal limits.

The owner, operator, contractor, or other persons will conduct all work and operations in accordance with proper safety codes for the type of construction being performed with due regards to the safety of all persons and property.

BASIS OF ACCEPTANCE

The acceptability of this practice shall be determined by inspections to insure compliance with all the provisions of this specification and to the drawings.

**NATURAL RESOURCES CONSERVATION SERVICE
PACIFIC ISLANDS AREA**

OPERATION AND MAINTENANCE PLAN

TERRACE (600)

Jobsheet Prepared for			
Client/Business Name:	<i>Steve & Aileen Camello</i>		
Planned Amount:	<i>300 ft.</i>	Job Class:	
Jobsheet Prepared by			
Name/Title:	<i>Thomas W. Esgate</i>	Date Prepared:	<i>1/20/2014</i>

This Operation and Maintenance Plan provides the minimum requirements for maintaining your terrace(s) to ensure proper functioning and longevity.

- Periodic inspections, especially immediately following significant runoff events.
- Prompt repair or replacement of damaged components.
- Maintenance of terrace ridge height, channel profile, terrace cross-sections and outlet elevations.
- Removal of sediment that has accumulated in the terrace channel to maintain capacity and grade.
- Regular cleaning of inlets for underground outlets. Repair or replacement of inlets damaged by farm equipment. Removal of sediment around inlets to ensure that the inlet remains the lowest spot in the terrace channel.
- Where vegetation is specified, periodic mowing and control of trees and brush.
- Notification of hazards concerning machinery and steep slopes on the terrace.
- Specify any additional operation and maintenance items related to the above requirements, as needed:

CONTACT YOUR LOCAL NATURAL RESOURCES CONSERVATION SERVICE CENTER OFFICE FOR ADDITIONAL TECHNICAL ASSISTANCE YOU MIGHT NEED FOR IMPLEMENTATION OF THIS OPERATION AND MAINTENANCE PLAN.

**NATURAL RESOURCES CONSERVATION SERVICE
PACIFIC ISLANDS AREA**

CONSERVATION PRACTICE SPECIFICATION

PIPELINE

SCOPE

This specification covers the installation of pipelines for livestock, wildlife or recreational use. Construction shall be in accordance with the plans and these specifications.

INSTALLATION

Materials. Materials for pipelines shall meet the requirements shown in the plans and be field inspected for deficiencies prior to installation.

Steel pipe shall meet the requirements of AWWA Specification C-200.

Plastic pipe shall conform to the requirements of the following ASTM specifications, as applicable:

D 1527 Acrylonitrile-Butadiene-Styrene (ABS) Plastic Pipe, Schedules 40 and 80

D 1785 Poly(Vinyl Chloride) (PVC) Plastic Pipe, Schedules 40, 80, and 120

D 2104 Polyethylene (PE) Plastic Pipe, Schedule 40

D 2239 Polyethylene (PE) Plastic Pipe (SIDR-PR) Based on Controlled Inside Diameter

D 2241 Poly(Vinyl Chloride) (PVC), Pressure-Rated Pipe (SDR)

D 2282 Acrylonitrile-Butadiene-Styrene (ABS) Plastic Pipe (SDR-PR)

D 2447 Polyethylene (PE) Plastic Pipe, Schedules 40 and 80, Based on Outside Diameter

D 2513 Thermoplastic Gas Pressure Pipe, Tubing and Fittings

D 2737 Polyethylene (PE) Plastic Tubing

D 2672 Joints for IPS PVC Using Solvent Cement

D 3035 Polyethylene (PE) Plastic Pipe (SDR-PR) Based on Controlled Outside Diameter

AWWA C900 Polyvinyl Chloride (PVC) Pressure Pipe, 4 inches through 12 inches

AWWA C901 Polyethylene (PE) Pressure Pipe and Tubing, ½ inch through 3 inches

High density polyethylene pipe (HDPE) shall be identified as Type III, Class C, Category 5, Grade P34. Materials for HDPE pipe shall be PE 3408 and have properties that conform to the requirements of the following ASTM specifications, as applicable:

D 1248 Polyethylene Plastics Molding and Extrusion Materials

D 3350 Polyethylene Plastics Pipe and Fitting Materials

Plastic pressure pipe fittings shall conform to the following ASTM specifications, as applicable:

D 2464 Threaded Poly (Vinyl Chloride) (PVC) Plastic Pipe Fittings, Schedule 80

D 2466 Poly (Vinyl Chloride) (PVC) Plastic Pipe Fittings, Schedule 40

D 2467 Poly (Vinyl Chloride) (PVC) Plastic Pipe Fittings, Schedule 80

D 2468 Acrylonitrile-Butadiene-Styrene (ABS) Plastic Pipe Fittings, Schedule 40

D 2609 Plastic Insert Fittings for Polyethylene (PE) Plastic Pipe

D 2683 Socket-Type Polyethylene Fittings for Outside Diameter-Controlled Polyethylene Pipe and Tubing

D 3139 Joints for Plastic Pressure Pipes Using Flexible Elastomeric Seals

D 3261 Butt Heat Fusion Polyethylene (PE) Plastic Fittings for Polyethylene (PE) Plastic Pipe and Tubing

Solvents for solvent-welded plastic pipe joints shall conform to the following ASTM specifications, as applicable:

D 2235 Solvent Cement for Acrylonitrile-Butadiene-Styrene (ABS) Plastic Pipe and Fittings

D 2564 Solvent Cements for Poly (Vinyl Chloride) (PVC) Plastic Pipe and Fittings

D 2855 Making Solvent-Cemented Joints with Poly (Vinyl Chloride) (PVC) Pipe and Fittings

Rubber gaskets for pipe joints shall conform to the requirements of ASTM F477, Elastomeric Seals (Gaskets) for Joining Plastic Pipe.

Placement. Pipelines shall be placed so they are protected against hazards imposed by traffic, livestock, farm operations, or soil cracking.

Plastic pipe shall be buried or covered with soil for protection from sunlight and the hazards mentioned above. Depth of cover should be 6 inches in locations where the pipeline is not subject to hazards from traffic or farm operations and protection is needed from sunlight only. If protection is needed from traffic and farm operations, the minimum depth of cover should be 18 inches.

Trenches for plastic pipelines shall be free of rocks and other sharp-edged materials. Plastic pipelines may be placed by "plow-in" equipment where soils are suitable and rocks and boulders will not be detrimental to the pipe.

High-density polyethylene pipe, Grade 34, PE 3408, may be laid in a "snake-like" position on ground surface at locations where minimal hazards are imposed by fire, farm operations, and traffic. At vehicle crossings, encasement of pipe or other approved methods shall be used. In areas where burning is very likely, such as pineapple and sugarcane fields, the pipe shall be buried a minimum of 18 inches. Pipes laid on steep slopes should be anchored to control creep and resulting added stresses.

Joints and Connections. All joints and connections shall be made to withstand the design maximum working pressure for the pipeline without leakage and shall leave the inside of the line free of any obstruction that may reduce its capacity below design requirements.

All fittings, such as couplings, reducers, bends, tees, and crosses, shall be installed in accordance with the recommendations of the pipe manufacturer.

Pressure Testing. Before backfilling, the pipe shall be filled with water and tested at design working head or a minimum head of 10 feet, whichever is greater. All leaks shall be repaired and the test repeated before backfilling.

Plowed-in pipelines will be pressure tested at the working pressure for 2 hours. The allowable leakage shall not be greater than one gallon per diameter inch per mile. Should the test exceed

this rate, the defect shall be repaired until retests show that the leakage is within the allowable limits, but all visible leaks must be repaired.

Backfilling. All backfilling shall be completed before the line is placed in service. The backfilling may be done using either hand, mechanical, or water-packing methods.

The initial backfill material shall be selected soil or sand free from rocks or stones larger than one inch in diameter. At the time of placement, the moisture content of the material shall be such that the required degree of compaction can be obtained with the backfill method to be used. The initial backfill material shall be so placed that the pipe will not be displaced, excessively deformed, or damaged.

When hand or mechanically backfilling, the initial fill shall be compacted firmly around and above the pipe as required to provide adequate lateral support to the pipe.

When water packing is used, the pipeline first shall be filled with water. The initial backfill, before wetting, shall be of sufficient depth to insure complete coverage of the pipe after consolidation has taken place. Water packing is accomplished by adding water to diked reaches of the trench in such quantity as to thoroughly saturate the initial backfill without excessive pooling of water. After saturation, the pipeline shall remain full until after final backfill is begun.

Backfill of plastic pipe should be done after the pipe reaches the same temperature as the water or soil. This can be done in a number of ways such as filling with water or by leaving the trench open overnight before backfilling.

BASIS OF ACCEPTANCE

The acceptability of this practice shall be determined by inspections to insure compliance with all the provisions of this specification and to the drawings.

WORKMANSHIP

All construction shall be performed in a workmanlike manner, and the job site shall have a neat appearance when finished.

All disturbed areas not graveled or paved will be vegetated to control erosion.

CONSTRUCTION OPERATIONS

Construction operations shall be carried out in such a manner and sequence that erosion and air and water pollution are minimized and held within legal limits.

The owner, operator, contractor or other persons will conduct all work and operations in accordance with proper safety codes for the type of construction being performed with due regards to the safety of all persons and property.

SAFETY

Landowners or operators, sponsoring organizations, and contractors shall be liable for damage to utilities and damage resulting from disruption of service caused by construction activities. The Natural Resources Conservation Service makes no representation on the existence or non-existence of any utilities. Absence of utilities on the drawings is not assurance that no utilities are present at the site.

It is the responsibility of the landowner or operator to determine if there are buried or overhead utilities in the vicinity of the proposed work. They should take proper procedures to insure that the utilities shall not be jeopardized and that equipment operators and others will not be injured during construction operations.

**NATURAL RESOURCES CONSERVATION SERVICE
PACIFIC ISLANDS AREA
CONSERVATION PRACTICE SPECIFICATION
WATERING FACILITY (614)**

SCOPE

The work shall consist of furnishing materials and constructing a water tank, watering trough, and/or other watertight container, with appurtenances to the dimensions and elevations as shown on the drawings or as staked in the field. Construction shall be in accordance with the drawings and these specifications.

SAFETY

Landowners or operators, sponsoring organizations, and contractors shall be liable for damage to utilities and damage resulting from disruption of service caused by construction activities.

It is the responsibility of the landowner or operator to determine if there are buried or overhead utilities in the vicinity of the proposed work. They shall follow proper procedures to insure that the utilities are not jeopardized and that equipment operators and others will not be injured during construction operations. They will conduct all work and operations in accordance with the proper safety codes for the types of construction being performed with due regard to the safety of all persons and property.

The Natural Resources Conservation Service makes no representation on the existence or non-existence of any utilities. Absence of utilities on the drawings is not assurance that no utilities are present at the site.

CONSTRUCTION OPERATIONS

Construction operations shall be carried out in such a manner and sequence that erosion and air and water pollution are minimized and held within legal limits.

The owner, operator, contractor or other persons will conduct all work and operations in accordance with proper safety codes for the type of construction being performed with due regards to the safety of all persons and property.

Building Permit. It is the owner's responsibility to obtain and display the appropriate building permit.

SITE PREPARATION, FOUNDATION PREPARATION, AND EARTHWORK

Before any material placement, the foundation area and the immediate surrounding area shall be; leveled, scarified, compacted, graded, and smoothed to permit free drainage of surface water without erosion. All bedding and backfill for underground pipes shall be compacted to the degree required to prevent settlement after construction is completed.

The foundation material shall be placed on the foundation per the drawings. When on-site materials exist, or can be reworked to provide a well-drained base, imported drain materials may not be required. The surface of the base material shall be smooth and without sharp protruding rocks to prevent damage to the bottom of the tank or trough.

The base material shall surround the outside of trough or tank as shown on the drawings. The base material for the bottom of the trough or tank shall be at least 2 inches above the surrounding ground surface.

The foundation shall be approved by an NRCS employee with appropriate engineering job approval authority.

MATERIALS AND INSTALLATION

General. All materials, placement, anchoring, proportioning, and protection shall be as shown on the drawings.

Piping. All piping for inlet, outlet, and overflow fittings of the tank or trough shall be new.

Reinforced concrete. For small jobs, the concrete mix will be: 1 sack cement (1 cubic foot), 2 cubic feet sand, 3-1/2 cubic feet gravel and no more than 6 gallons water. For larger jobs, concrete will be proportioned and mixed to produce a 28-day strength of 3,000 pounds per square inch or greater.

Reinforcing steel is to be placed as indicated on the plans and held securely in place during concrete placement. Subgrades and forms are to be installed to lines and grades and the forms are to be mortar-tight and unyielding as the concrete is placed.

All concrete shall be vibrated or rodded in the forms. Concrete surfaces shall be finished to where no voids, honeycombed areas, rough edges or obstructions exist.

The bond area between a floor slab and reinforced concrete wall shall be thoroughly roughened and cleaned to insure a good bond.

Concrete shall be cured by keeping exposed surfaces wet for a minimum of 7 days or by applying an acceptable curing compound.

Concrete masonry (hollow-tile block). Mortar for concrete masonry shall be freshly prepared and uniformly mixed in a ratio by volumes of 1 part cement, 1/2 part lime putty, and 4-1/2 parts sand. If plastic-type cement is used, the lime putty shall be omitted.

Grout for the cells of concrete hollow-tile blocks shall be of stiff consistency sufficient to fill the cells without voids or air pockets and mixed in the ratio by volume; 1 part cement, 3 parts sand; or 1 part cement, 3 parts sand, and 2 parts 3/8" crushed rock.

Corrugated metal sheets. The base ring of the tank should be assembled directly on the base material. Vertical joints of the section plates of the second tank ring shall be positioned approximately above the center of the section plates of the bottom tank ring. This staggering of the section plates shall be followed throughout the tank construction. Connections shall be the bolt and washer on the inside of the tank and the nut on the outside.

Mild Steel. Tanks or troughs made of mild steel shall be built in accordance with this specification, as applicable, and PI Conservation Construction Specification 111, Metal Fabrication.

Anchoring. Tanks and tanks shall be secured to prevent movement as noted on the drawings.

Workmanship. The flat bottoms and top edges of tanks and troughs shall be level.

All construction shall be performed in a workmanlike manner, and the job site shall have a neat appearance when finished. All disturbed areas not graveled or paved will be vegetated to control erosion as per the drawings.

The bottom ring of the tank should be assembled directly on the base material. Vertical joints of the section plates of the second tank ring shall be positioned approximately above the center of the section plates of the bottom tank ring. This staggering of the section plates shall be followed throughout the tank construction.

Bolting shall be per the manufacturer's recommendations to ensure a durable connection. In all cases, the bolt head (cap-screw or carriage bolt) will be on the inside of the tank and the nut on the outside with the washer(s) per the manufacturer's guidelines.

The concrete for the entire floor and foundation shall be placed continuously and as one unit. A construction joint shall be formed between the floor and the wall as shown on the drawings. The construction joint between wall and floor shall also be water tight. The bond area between a floor slab and reinforced concrete wall shall be thoroughly roughened and cleaned to insure a good bond.

CERTIFICATION

The manufacturer or installing contractor of the watering facility shall furnish a written guarantee that protects the owner against defective workmanship and materials for not less than one year. Written guarantee shall also state that the installation and/or materials meet NRCS Practice Standards and Specifications.

BASIS OF ACCEPTANCE

The acceptability of this practice shall be determined by inspections during and following construction to ensure compliance with all provisions of this specification and the construction drawings.

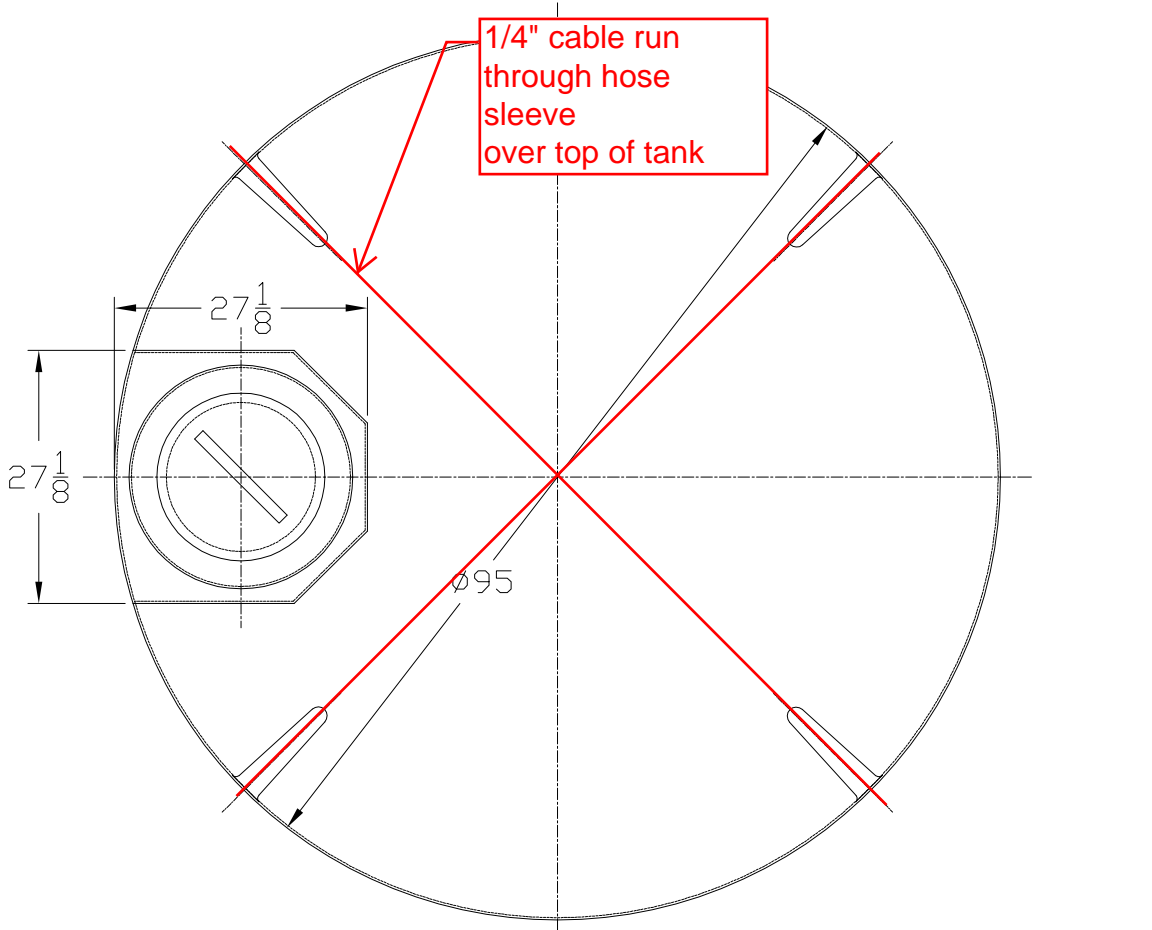

1/4" cable run through hose sleeve over top of tank

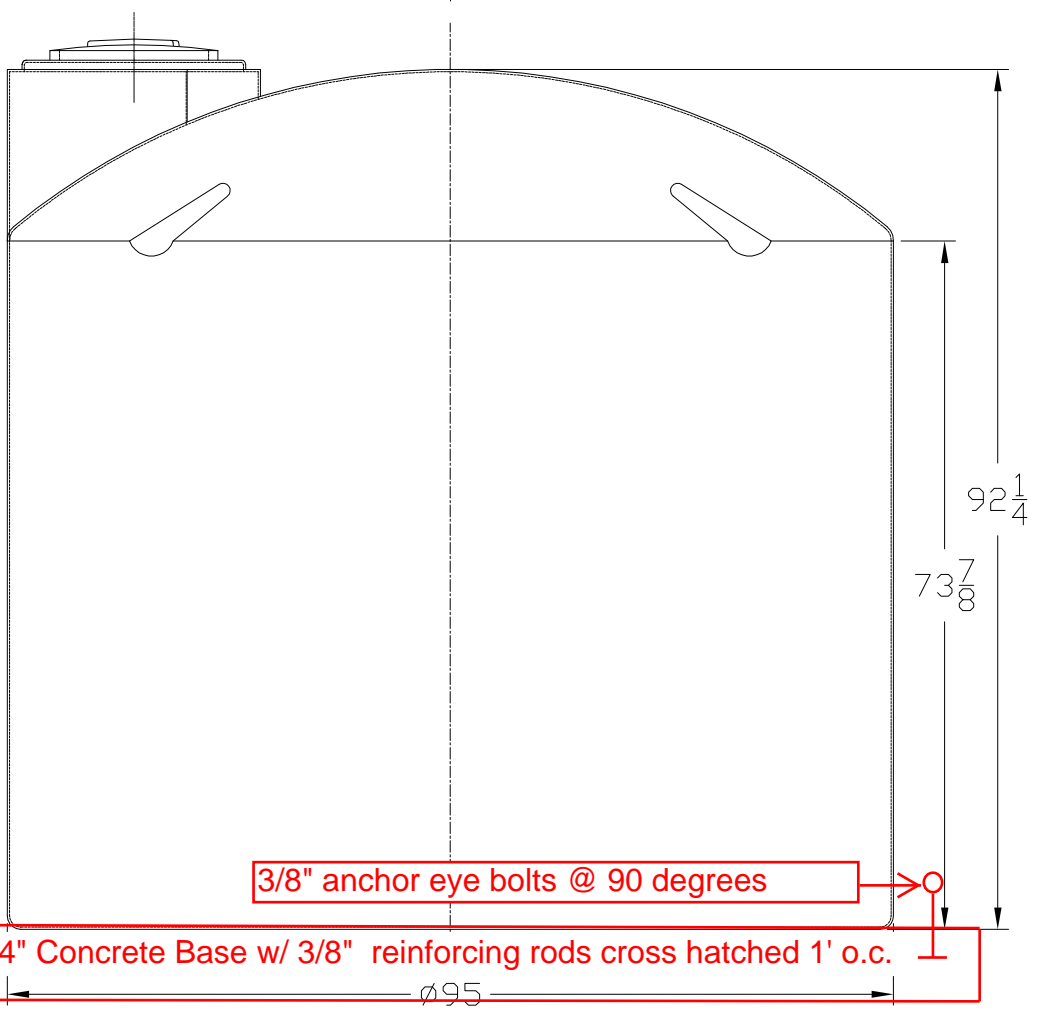
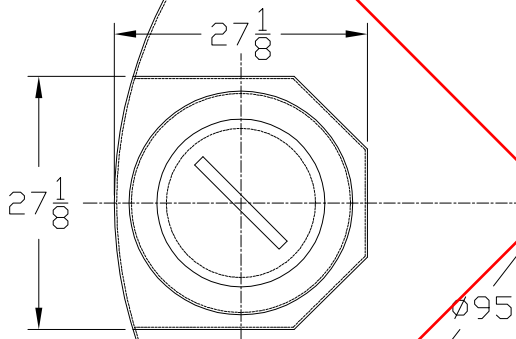

3/8" anchor eye bolts @ 90 degrees

4" Concrete Base w/ 3/8" reinforcing rods cross hatched 1' o.c.

THIS DRAWING & DESIGN IS THE PROPERTY OF CHEM-TAINER INDUSTRIES INC. IT MAY NOT BE USED FOR ANY PURPOSE OTHER THAN BY THE OWNER. CHEM-TAINER DOES NOT AUTHORIZE THE REPRODUCTION OR CONVEYANCE OF ANY INFORMATION CONTAINED HEREIN.

TANK WALL THICKNESS:

- IA -- 0.40-INCH
- IC -- 0.36-INCH
- IW -- 0.31-INCH

ALL DIMENSIONS SHOWN ARE OUTSIDE PART DIMENSIONS IN INCHES, AND VARY BY THE STANDARD ROTATIONAL MOLDING TOLERANCE OF ±2%.

Rev: 1	Date: 05/15/00	File Name: IA9592-1
CHEM-TAINER		
Industries Inc.		
361 Neptune Ave. W. Babylon, NY 11704		
(631) 661-8300 Fax: (631) 661-8209		
TITLE	Date: 05/15/00	Mold Location: HI
2500 GAL. VERTICAL BULK STORAGE TANK	Drawn By: IIA	Cust. Rep.
Part #	Dwg. #	
TC9592IA/IC/IW	C-9592-1H	

Tank Handling, Installation & Use Guidelines

Although Chemtainer's tanks are extremely durable, improper handling and installation can result in damage to tank, fittings, and accessories. Failure to comply with handling and installation instructions voids all warranties.

1. At delivery, inspect your tank immediately for defects or shipping damage. Any discrepancies, or product problems, should be noted on both the driver's bill of lading and your packing list.
2. When unloading your tank from the delivery truck, avoid its contact with sharp objects. Forklift blades can cause significant damage if proper precautions are not taken. Do not allow tanks to be rolled over on the fittings. Large bulk storage tanks, whenever possible, should be removed from truck bed by use of a crane or other suitable lifting device. OSHA regulation 29CFR 1910.178 through 1910.189 addresses specific standards for hoisting and lifting. Keep unloading area free of rocks, sharp objects, and other materials that could damage the tank. If tank is unloaded on it's side, carefully brace to prevent rolling.
3. Support bottom of tank firmly and completely. Concrete pads provide the best foundation. However, when seismic and wind factors are not being considered, tanks with a base load bearing of less than 800 pounds per square foot require a firm, even, compacted bed of sand, pea gravel, or fine soil that won't wash away. Tanks with a base load bearing of 800 pounds per square foot, or greater, require a reinforced concrete base. Steel support stands concentrate the loaded tank weight onto the stand leg pads. It is recommended that stands are mounted on a concrete base. Bolting of stands is necessary to prevent movement due to agitation, wind, seismic loads and accidental contact.
4. Install tanks in an area that is accessible. Ease of maintenance and removal should be considered.
5. Test by filling tank with water prior to use, to prevent material loss through unsecured fittings, shipping damage, or manufacturing defects. Tanks should be tested for a minimum 5 hours.
6. Plastic screw on bulkhead fittings are designed to be hand tightened. Overtightening can cause fittings to leak.
7. Support sides of rectangular tanks. In general, tanks with heights greater than 18" must be supported. However, specific applications must be considered: smaller tanks with contents that have high specific gravity and/or elevated temperatures must be supported.
8. Do not mount heavy equipment on tank sides.
9. Do not allow weight on tank fittings. Fully support pipes and valves.
10. Use expansion joints to prevent damage at fittings from the differential expansion and contraction of the piping and tanks.
11. Tanks are designed for use only in the atmospheric storage of chemicals, never for vacuum or pressure applications.

12. Immersion heaters should never touch the walls of the tank. Minimum spacing should be 3" - 4" from wall.

13. Refer to the chemical capability chart on this site as a guide. Be certain tank, fittings, and fitting gasket material are compatible with chemicals at the anticipated operating temperatures. Contact our technical staff for information on chemicals not listed, or when uncertain conditions exist.

14. Protect tanks from impact, especially at temperatures below 40 degrees F.

15. Confined spaces must be considered hazardous. Do not enter tank without first taking proper precautions.

16. Tank sizes as listed are nominal and calibrations on molded tanks are only approximates, but provide an indication of volume. Polyethylene tanks expand and contract which will effect volume. The degree in which this occurs depends on the size of the tanks, wall thickness, specific gravity of contents, temperature of contents and ambient temperatures.

Contour Farming for Orchards in the Pacific

USDA NRCS Practice (331)

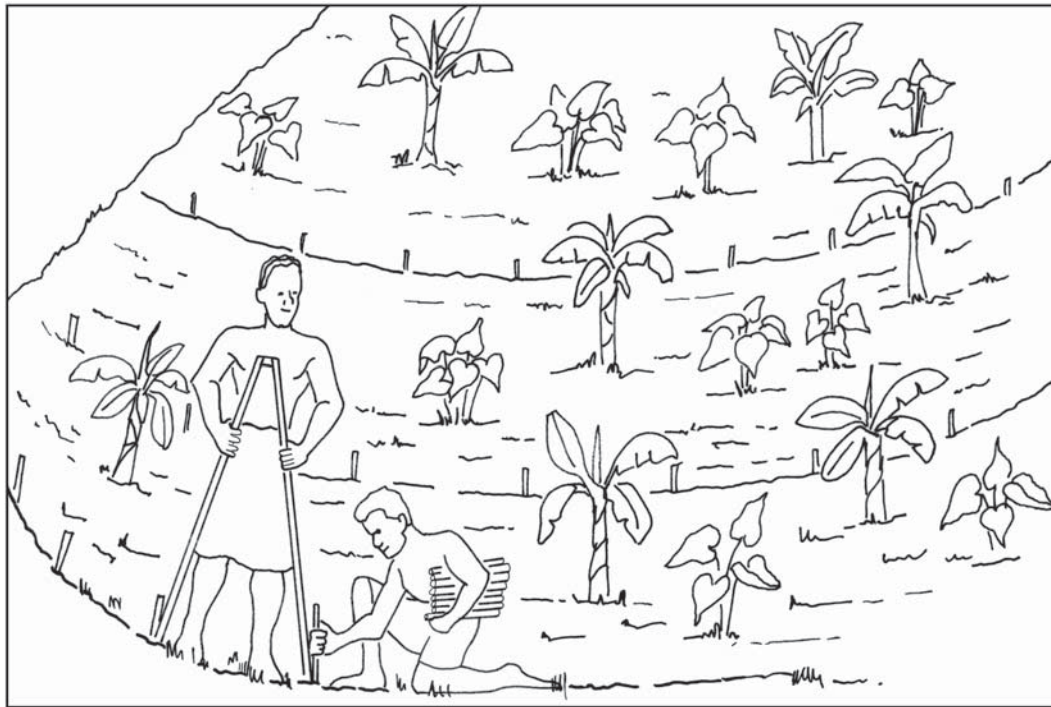

In contour farming, tree crops are planted across the slope to conserve water and protect soil. This is done with simple instruments such as a level or a homemade A-frame.

What is contour farming for orchards?

A traditional Pacific Island practice that is very beneficial for growing tree crops on hillsides is to plant the tree rows across the slope instead of up and down the slope. A common name for this practice is **contour farming**. It is a very old and effective conservation practice used by farmers from around the world.

Why plant orchards on the contour?

Pacific Island farmers can benefit from planting their tree crops across the slope on their farm. Using this practice can:

- keep valuable topsoil in place on sloping fields.
- slow water down and let it soak into the soil.
- improve irrigation systems and conserve water.
- reduce labor and make harvesting easier.
- improve the appearance of the farm.

To learn more about protecting your sloping farm land from water damage, read ***Protecting Soil on Pacific Island Farms.***

Where is contour farming used?

- On sloping orchards

If you grow trees (for wood, fuel, fruit, nuts, cultural or medicinal uses) on slopes, you should be aware of water movement. Be extra careful to protect your orchard soils from water damage. Plan for heavy rain before the rains actually fall. Long, smooth, even slopes speed up runoff water. Fast moving water has a lot of power to cut deep into the land. It can wash soil off your field and damage or even destroy your trees. Use conservation practices to shorten slope lengths, make them more irregular, and slow down rainwater.

Start with planting on the contour

As a farmer, your first step for slowing down rainwater is to determine your field's contour lines. Then plant your orchard across the slope (or "on the contour"). This allows you to do all the land preparation, planting, and harvesting across the slope. Farming across the slope helps to shorten slope lengths, slowing down runoff water so it can soak into the soil.

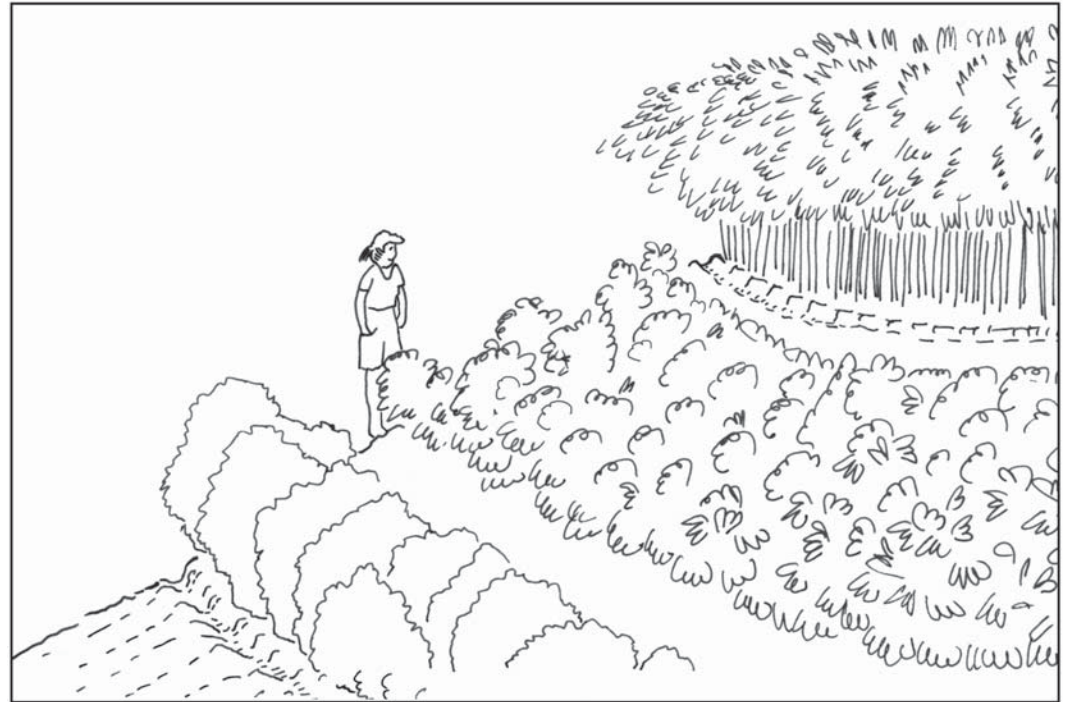

Combine contour farming with hedgerows to keep valuable topsoil in place on sloping fields and to produce a variety of different crops.



Combine contour farming with hillside ditches to slow water down and let it soak into the soil.

It is important to take time to lay out contour lines to guide you in the field. This is done with simple instruments such as a level or a homemade A-frame. Your local office of the USDA NRCS or the Cooperative Extension Service can help show you how to lay out contour lines.

Add on other practices

For more slope protection, combine contour orchard farming with other practices. You can plant conservation covers, vegetative barriers, and alley cropping hedgerows in strips or rows across the slope. Use mulching and residue management to keep the soil under the trees covered. Place slash or plant residue (such as banana stalks and tree trimmings) in strips across the slope to help trap and retain water.

With some basic earth shaping, you can install hillside ditches across the slope. This will shorten the slope length and divert water to a stable area on the farm.

With each additional practice, the farm is better protected from water damage.

For the best results, combine **contour farming** with other conservation practices:

- **Hillside Ditch** (423): digging a small ditch across the slope to divert rainwater
- **Vegetative Barriers** (601): growing small strips of stiff plants across the slope
- **Residue Management** (329): leaving slash in the field for soil protection
- **Mulching** (484): bringing in material to cover and protect the soil
- **Conservation Cover** (327): growing permanent plant cover to protect topsoil and smother weeds
- **Alley Cropping** (311) and **Hedgerow Planting** (422): growing hedges of shrubs and trees across the slope

Additional information is available from your local USDA Service Center or at www.pb.nrcs.usda.gov and www.hi.nrcs.usda.gov.

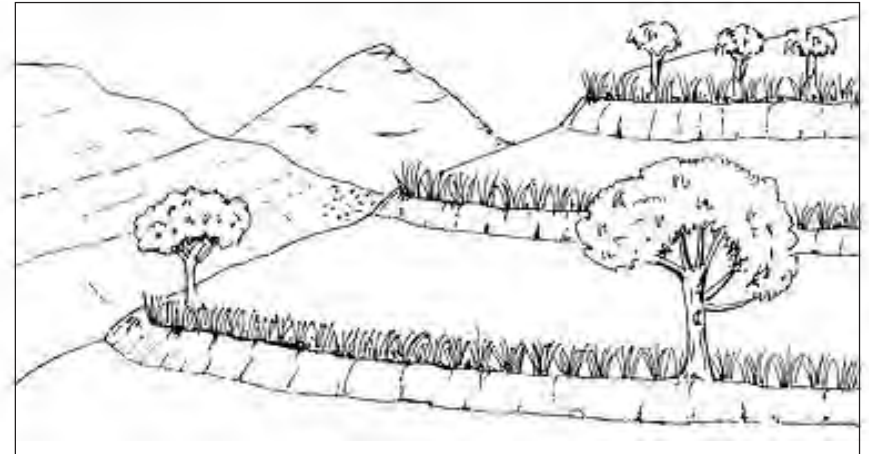

For the best results, combine contour farming with vegetative barriers and other conservation practices.

**NATURAL RESOURCES CONSERVATION SERVICE
PACIFIC ISLANDS AREA**

CONSERVATION PRACTICE STANDARD

CONTOUR ORCHARD AND OTHER PERENNIAL CROPS

(Ac.)
CODE 331

DEFINITION

Planting orchards, vineyards, or other perennial crops so that all cultural operations are done on or near the contour.

PURPOSE

- Reduce soil erosion
- Reduce transport of sediment and other associated contaminants
- Increase infiltration

CONDITIONS WHERE PRACTICE APPLIES

This practice applies on sloping land where orchards, vineyards, or other perennial crops are to be established. For annually planted crops use the practice Contour Farming (330).

CRITERIA

General Criteria Applicable to All Purposes

Overland flow from adjacent sites shall be diverted as necessary to ensure the proper functioning of this practice.

Row Grade. The row grade will be aligned as closely to the contour as feasible, but the maximum row grade shall not exceed:

- one-half of the up-and-down hill slope percent used for conservation planning, or
- 10 percent,

whichever is less.

Up to a 25% deviation from the design row grade is permitted within 150 feet of a stable outlet.

When the row grade reaches the maximum allowable design grade, a new baseline shall be established up or down slope from the last contour line and used for layout of the next contour pattern.

The row grade shall not be less than 0.2 percent on soils with slow to very slow infiltration rates (hydrologic soil group C or D) or where the crop to be planted will be damaged by ponded water conditions for periods of less than 48 hours.

Critical Slope Length. This practice shall not be installed on a hill slope that is longer than the critical slope length.

When the critical slope length is exceeded, the slope length shall be divided through the use of diversions, terraces, or other structures to shorten slope lengths.

The critical slope length shall be determined using currently approved erosion prediction technology.

Stable Outlets. Runoff from contour rows shall be delivered to a stable outlet.

CONSIDERATIONS

This practice is most effective on slopes between 2 and 10 percent. It will be less effective in achieving the stated purpose(s) on slopes exceeding 10 percent and in areas with 10-year EI (EI = total storm energy times the maximum 30-minute intensity) values greater than 140. *See the Conservation Practice Specification for EI maps and values for the Pacific Islands Area.*

Fields that are cut by gullies or have strongly undulating topography are not well suited for this practice because of the difficulty of meeting the row grade criteria.

A topographic survey will usually be needed to see if the desired planting pattern will fit the slopes.

Avoid applying this practice on areas that have evidence of mass movement or have the potential for landslides.

Following the level contour may not be desirable where slow drainage may increase disease problems or where furrows could fill with water and overtop.

Planting orchards and fruit areas on the contour generally requires a bench or terrace to be constructed to provide access to the growing trees or shrubs. The bench or terrace may reduce surface runoff and increase the opportunity for infiltration. Either inward sloping or outward sloping benches may be appropriate.

Inward sloping benches reduce runoff. The reduction depends on the amount of surface storage and the intake rate of the soil.

Where inward sloping benches are used, potential contaminants will be trapped against the slope. With some rainfall events, the bench can provide as much as 100 percent trap efficiency.

Where outward sloping benches are constructed for drainage purposes, runoff may be more or less than from the unbenched condition. The degree of runoff reduction will depend on the angle of the outward slope, the amount of cover on the bench at the time of runoff, the amount of storage available, the intake rate of the surface soil, and the amount of water received (either rainfall or irrigation).

The amount of potential contaminants retained on outward sloping benches depends on the slope of the bench and the amount of cover. In addition, outward sloping benches are subject to erosion caused by runoff from benches immediately above them.

Contouring can improve access to fields, facilitate maintenance and improve energy efficiency.

This practice works best as a system in combination with vegetative ground cover and appropriate irrigation conveyance practices, where applicable.

Vegetative ground cover, particularly in alleys between rows of trees/vines, in row furrows, and on terraces and diversions can increase infiltration, reduce runoff, aid in controlling erosion, provide habitat for beneficial species and pollinators, and facilitate nutrient cycling.

Where sites are disturbed, temporary erosion control measures should be applied until the planting is established.

PLANS AND SPECIFICATIONS

Plans and specifications are to be prepared for each field.

Specifications for establishment of this practice shall be prepared for each field according to the Criteria, Considerations, and Operation and Maintenance described in this standard. The plans shall include, as a minimum:

- Percent land slope used for conservation planning;
- The minimum and maximum allowable row grades for the contour system;
- A sketch map or photograph of the field showing:
 - ◇ the approximate location of the baselines used to establish the system
 - ◇ the location of stable outlets for the system

The Pacific Islands Area Jobsheet for this practice shall be used to prepare and record the plans and specifications for each site and reviewed with the client.

Evaluation of the conservation system using the currently approved water erosion prediction technology will be documented in the plan.

OPERATION AND MAINTENANCE

Maintenance needed for this practice includes:

- Performing all cultural operations between tree or vine rows on or near the contour.
- Periodic inspection and repairs to runoff water outlets
- Protecting uphill and downhill farm roads from erosion, and
- Maintaining adequate vegetative cover to control erosion.

The Pacific Islands Area Jobsheet for this practice shall be used to prepare and record the maintenance requirements for each site and reviewed with the client.

REFERENCES

Foster, G.R., D.C. Yoder, G.A. Weesies, D. K. McCool, K.G. McGregor, and R.L. Binger. 2003. *User's Guide – Revised Universal Soil Loss Equation (RUSLE2)*. Version 2. USDA. http://fargo.nserl.purdue.edu/rusle2_dataweb/RUSLE2_Index.htm.

Renard, K. G., G. R. Foster, G. A.. Weesies, D. K. McCool, and D. C. Yoder. 1997. *Predicting soil erosion by water: A Guide to conservation planning with the Revised Universal Soil Loss Equation (RUSLE)*. Agriculture Handbook 703. USDA.

**NATURAL RESOURCES CONSERVATION SERVICE
PACIFIC ISLANDS AREA**

CONSERVATION PRACTICE STANDARD

ROW ARRANGEMENT

(Ac.)
CODE 557

DEFINITION

A system of crop rows on planned grades and lengths.

PURPOSE

Establish crop rows in direction, grade and length to:

- Provide adequate drainage
- Provide erosion control
- Permit optimum use of rainfall and irrigation water.

CONDITIONS WHERE PRACTICE APPLIES

Proper row arrangement is applicable:

1. As part of a surface drainage system for a field where the rows are planned to carry runoff to main or lateral drains.
2. To facilitate optimum use of water in graded furrow irrigation systems.
3. In dryland areas where it is necessary to control the grade of rows to more fully utilize available rainfall.
4. On sloping land where control of the length, grade and direction of the rows can help reduce soil erosion, as a stand-alone practice or in conjunction with other conservation practices.

CRITERIA

General Criteria Applicable to All Purposes

Row arrangement shall be designed to accommodate the type and size of farm equipment to be used in the field.

Additional Criteria for Surface Drainage

As part of a surface drainage system, row arrangement shall:

1. Conform to the NEH, Part 650, Engineering Field Handbook, Chapter 14, Water Management (Drainage) for the area regarding grade, depth, and permissible velocities.
2. Facilitate flow of excess water from the field into surface ditches.

Additional Criteria for Furrow Irrigation

As part of a furrow irrigation system, row arrangement shall:

1. Conform to the irrigation guide for the area regarding grade and length.
2. Facilitate irrigation water management in the field.

Additional Criteria for Erosion Control and Water Conservation

As part of an erosion control and/or water conservation system for a field, row arrangement shall:

1. Conform to the particular Conservation Practice Standard for the area (such as 449, Irrigation Water Management) for which row arrangement is a facilitating measure.

2. Conform to the grade and length requirements for Conservation Practice Standard 600, Terrace if the arrangement is used without another engineering practice.

CONSIDERATIONS

When planning this practice as part of the Resource Management System for a field, the following considerations should be made for water quantity and quality, as applicable:

- Effects upon components of the water budget, especially on volumes and rates of runoff, infiltration, evaporation, transpiration, deep percolation and ground water recharge.
- The potential for a change in plant growth and transpiration due to changes in the volume of soil water.
- Effects on downstream flows and aquifers that would affect other water uses and users. This would include the effect of nutrients and pesticides on surface and ground water, the movement of dissolved substances below the root zone and toward the ground water, and soil water level control on the salinity of the soils, soil water or downstream water.
- Effects on the volume of downstream flow to prohibit undesirable environmental, social or economic effects, such as, effects on wetlands or water-related wildlife habitats.
- The effects on the water table of the field and/or soil moisture to ensure that it will provide a suitable rooting depth for the anticipated land uses.
- Potential use for water management to conserve water.

PLANS AND SPECIFICATIONS

Plans and specifications for row arrangement shall be in keeping with this standard and shall describe the requirements for properly applying the practice to achieve its intended purpose.

OPERATION AND MAINTENANCE

An O&M plan specific to the intended purpose of the row arrangement system shall be provided to the landowner.