

EQUIPMENT FOR HUSKING POHA BERRIES

Jaw-Kai Wang

CONTENTS

	PAGE
INTRODUCTION	3
ANALYSIS OF PROBLEM	4
EXPERIMENTAL	6
DESIGN AND TESTING OF A PROTOTYPE HUSKER	10
SUMMARY	14
APPENDIX	15
REFERENCES	18

Table

NUMBER

1. Field test results of prototype husker	14
---	----

Figures

1. Poha berries	4
2. Husked poha berry resting on rollers	5
3. Frictional coefficients between poha berry, husk, and two rubber surfaces	7
4. The determination of $F_{H\cdot\max}$	7
5. Effect of roller speed on crushing percentage	8
6. Unhusked berry resting on rollers	9
7. Laboratory husker	9
8. Laboratory husker with a feeder and a precutting attachment	11
9. Side view of the laboratory husker	12
10. Prototype husker and its drive mechanism	13
A-1. Dimensional drawing of mechanical poha berry husker. Front view	15
A-2. Dimensional drawing of mechanical poha berry husker. Side view	16
A-3. Dimensional drawing of mechanical poha berry husker. Top view	17

ACKNOWLEDGMENTS

The author wishes to acknowledge the following help and assistance he received in preparing this publication.

All of the field-testing was done at the Niolopa Hawaiian Jams and Jellies Company, Hilo, Hawaii, whose Manager, Mr. Y. Matsuno, and Office Manager, Mr. Z. Kanai, requested this study; they also provided the poha berries used in all the tests.

Mr. John Kuniyoshi, Shop Foreman, and Mr. Shigeo Higa constructed all the equipment used in this study.

THE AUTHOR

DR. JAW-KAI WANG is Associate Agricultural Engineer at the Hawaii Agricultural Experiment Station; Chairman, Department of Agricultural Engineering, College of Tropical Agriculture; and Associate Professor of Agricultural Engineering, University of Hawaii.

EQUIPMENT FOR HUSKING POHA BERRIES

JAW-KAI WANG

INTRODUCTION

The poha berry (*Physalis peruviana* L.) is a member of the nightshade (Solanaceae) family. When mature, the berry is yellow in color, approximately spherical in shape, and covered by a leafy husk.

Poha berry preserves have a distinct flavor and are enjoyed by Hawaii residents and visitors. However, there is very little commercial production of the poha berry, and processors must obtain their supplies through backyard growers, each of whom has a limited production and no quality control. This lack of commercial plantings also is reflected in the high price which processors pay for the poha berry, usually between \$0.20 to \$0.25 per pound, unhusked.

Another problem in the production of poha berry preserves is the high cost of processing the raw material into the finished product. The leafy husk that covers the poha berry must be removed, and at present this is done by hand. A fast worker may average 10 to 12 pounds of husked berries per hour.

It costs a processor about \$0.50 to produce 1 pound of poha jam, and at gift shops and supermarkets it is sold for more than a dollar a pound.

Some processors have been attempting to expand the market. To do this, the volume of the berry supply must be increased through increased commercial plantings; also, the high cost of hand-husking must be reduced.

A research project was initiated in 1962 to analyze the feasibility of husking poha berries mechanically, to determine the design requirements of such equipment, and, finally, to develop and test a mechanical husker which would be adaptable to commercial usage.

The results of the study are reported in this bulletin.

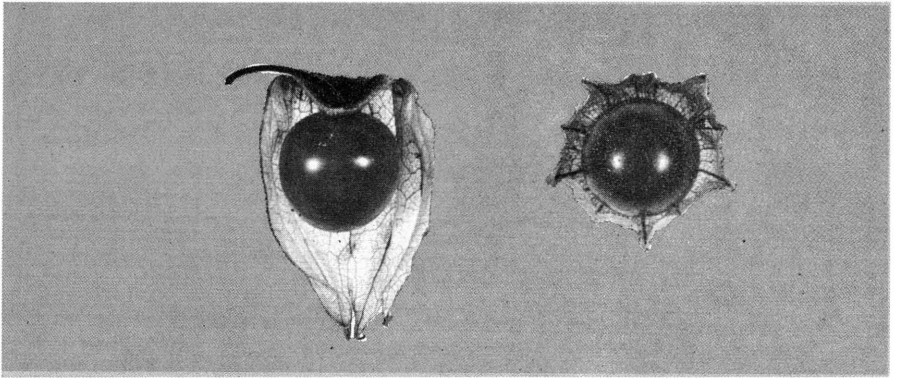

FIGURE 1. Poha berries.

ANALYSIS OF PROBLEM

Poha berries with their husks cut half open are shown in figure 1. The color of the berry varies from green to yellow, depending upon its maturity. The immature green berry is relatively strong, but the mature berry is juicy, and easily damaged by external forces. The husk of the berry is crisscrossed with veins and will stand strong tensile force.

That the frictional coefficients differ between the berry or its husk and a third material is obvious upon observation, and because of this difference in physical characteristics, it was decided that the removal of the poha berry husk could be accomplished by frictional rollers.

The forces acting on a berry when it rests on a pair of rotating rollers are shown in figure 2.

For the vertical components of the forces to be balanced, it follows that,

$$2F \sin \theta + W = 2N \cos \theta \quad (1)$$

$$F = \mu N \quad (2)$$

where F = frictional force between berry and rollers
 μ = kinetic frictional coefficient between berry and rollers

Combine equations (1) and (2),

$$2F \left(\sin \theta - \frac{\cos \theta}{\mu} \right) + W = 0 \quad (3)$$

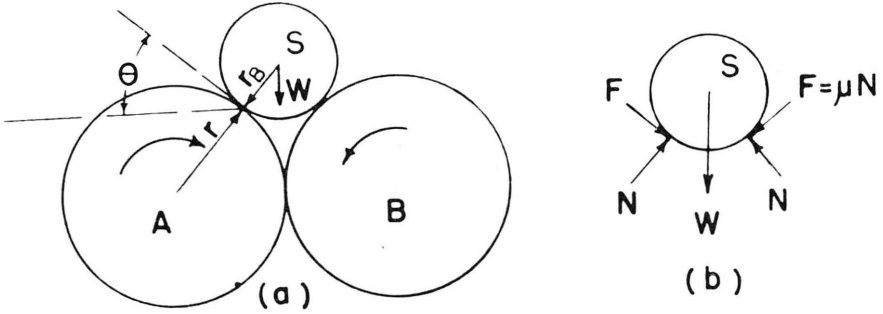

FIGURE 2. Husked poha berry resting on rollers.

r = radius of rollers A and B

r_B = radius of berry S

θ = angle between the berry S and rollers A and B

W = weight of berry S

Since W is the weight of the berry, its value must be greater than zero, or,

$$2F \left(\frac{\cos \theta}{\mu} - \sin \theta \right) = W > 0 \quad (4)$$

Hence,

$$\cot \theta > \mu \quad (5)$$

but,

$$\cot \theta = \frac{\sqrt{(r + r_B)^2 - r^2}}{r} = \sqrt{\frac{r_B}{r} \left(2 + \frac{r_B}{r} \right)} \quad (6)$$

Therefore,

$$\sqrt{\frac{r_B}{r} \left(2 + \frac{r_B}{r} \right)} > \mu \quad (7)$$

In equation (6), r_B is the radius of the berry and therefore not a variable. Since μ is positive and is determined by the surface material of the rollers, expression (7) establishes the maximum value for the radius of the rollers.

To sum the horizontal components of the forces,

$$F_H = 2(F \cos \theta + N \sin \theta) \quad (8)$$

where F_H = horizontal force applied on the berry by the rollers.
Combining equations (8), (2), and (1),

$$F_H = W \frac{\mu \cot \theta + 1}{\cot \theta - \mu} \quad (9)$$

There is a maximum horizontal force which poha berries can withstand. When subjected to pressures beyond this value, berries will crush. Call this pressure $F_{H \cdot \max}$; then,

$$F_{H \cdot \max} = W \frac{\mu \cot \theta + 1}{\cot \theta - \mu} > 0 \quad (10)$$

By its definition $F_{H \cdot \max}$ must be greater than zero. Also from expression (5) and the fact μ cannot be negative, it can be readily deduced that expression (10) must be true.

Expression (10) can be rewritten as follows:

$$\frac{\mu \cot \theta + 1}{\cot \theta - \mu} < \frac{F_{H \cdot \max}}{W} \quad (11)$$

Expression (11) establishes another limit for the radius of the rollers. However, in this instance the limit is related to $F_{H \cdot \max}$ and W . The significance of this relationship is discussed in the following section.

EXPERIMENTAL

From equation (7) it is evident that the values of frictional coefficients between the poha berry and the surfaces of the rollers are important. It can also be shown that, if the frictional force between the rollers and the husk of the poha berry is to be utilized to pull the husk from the berry, the frictional coefficients between the rollers' surfaces and the husk are also important.

Figure 3 shows frictional coefficients between the poha berry, its husk, and two different rubber surfaces. A schematic diagram shows how values of frictional coefficients are obtained.

The value of the maximum horizontal force, $F_{H \cdot \max}$, which the berries can withstand, is also important.

$F_{H \cdot \max}$ is determined by placing berries between two flat surfaces, as illustrated in figure 4, and gradually increasing the applied force. It was found that permanent deformation of berries occurred between an applied force of 2 to 2½ pounds; at 2½ pounds of force, berries break up.

The range in size of poha berries also needed to be determined. Thirty-five berries were selected at random and it was found that mature berries, purchased in the Hilo area, had diameters ranging from 0.375 inch to 0.675 inch.

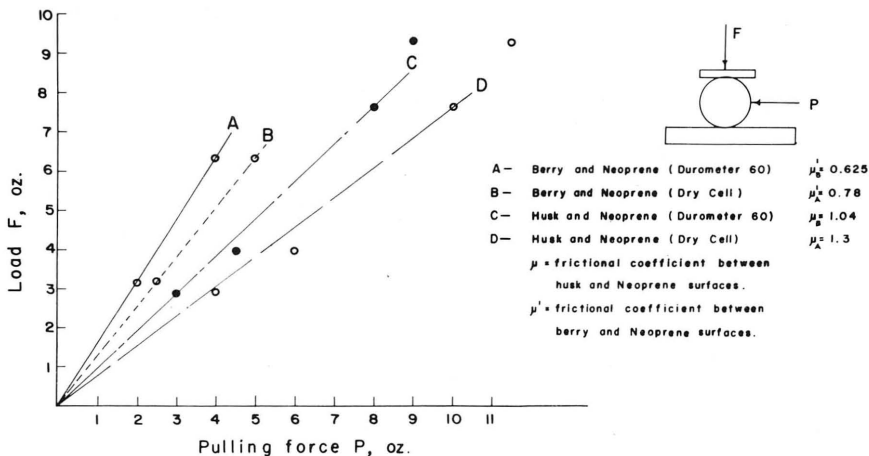

FIGURE 3. Frictional coefficients between poha berry, husk, and two rubber surfaces.

To determine the maximum radius of the rollers, as dictated by equation (7), the lower value of r_B and μ'_B should be used, or, $r_B = 0.187$ inch

$$\mu = \mu'_B = 0.625$$

Substitute into expression (7)

$$X^2 + 2X > (0.625)^2$$

$$\text{where } X = \frac{r_B}{r}$$

$$\text{or, } X^2 + 2X - 0.39 > 0$$

$$\text{or, } X > 0.18$$

$$\text{or, } r < 1.04 \text{ inches}$$

This means that rollers with radii less than 1.04 inches will satisfy the limiting condition of equation (7). Whether the limiting condition set forth by expression (11) is satisfied is another question, and it must be answered experimentally.

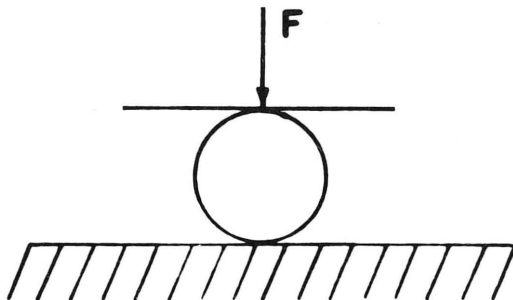

FIGURE 4. The determination of $F_{H \cdot \max}$.

W in expression (11) is the downward force exerted by the berry on the rollers. Usually,

$$W = \text{weight of berry}$$

and it is apparent from inspection that expression (11) must be satisfied. However, at the instant the husk is being pulled away from the berry,

$$W = \text{weight of berry} + \text{force of separation} \quad (12)$$

The force needed to separate the husk from its berry can be determined easily under near-static conditions. A berry can be held in place and a force applied to its husk. The applied force would then be increased until the husk was completely separated from the berry; the maximum force applied would be noted and this would then be the force of separation.

However, preliminary investigations have shown that the force of separation is influenced by the speed with which the husk is pulled away. The satisfaction of the condition set forth by expression (11) thus depends upon the rotational speed of the rollers which determines the speed of separation of the husk from its berry.

To determine the optimum roller speeds and sizes, four pairs of rollers were constructed. Two of the pairs had diameters of 0.625 inch, but one of

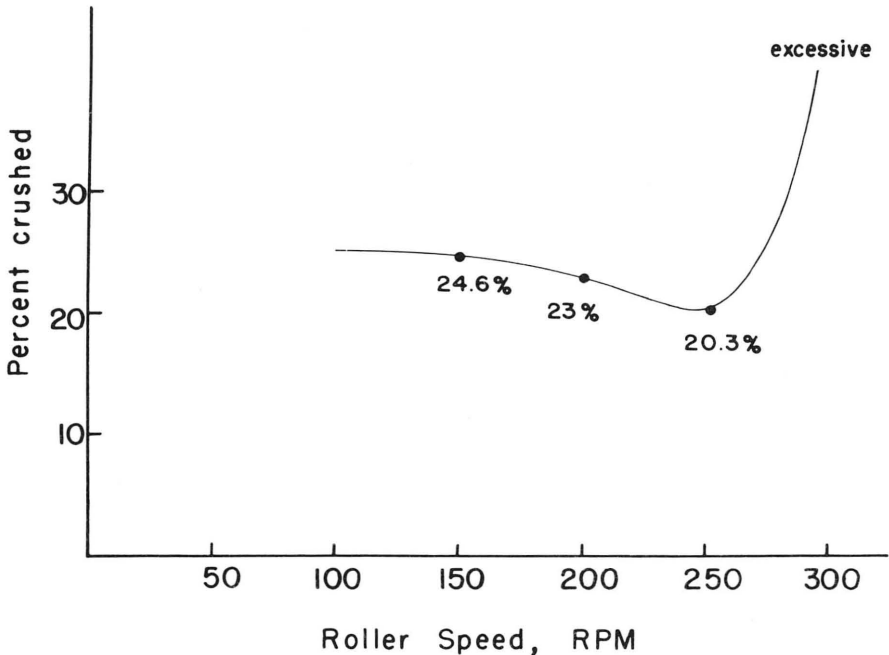

FIGURE 5. Effect of roller speed on crushing percentage.

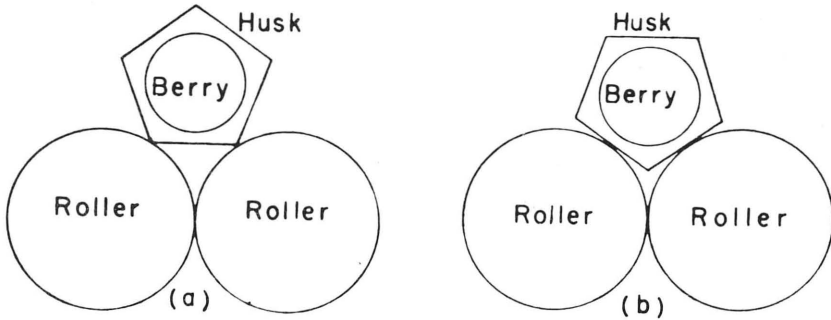
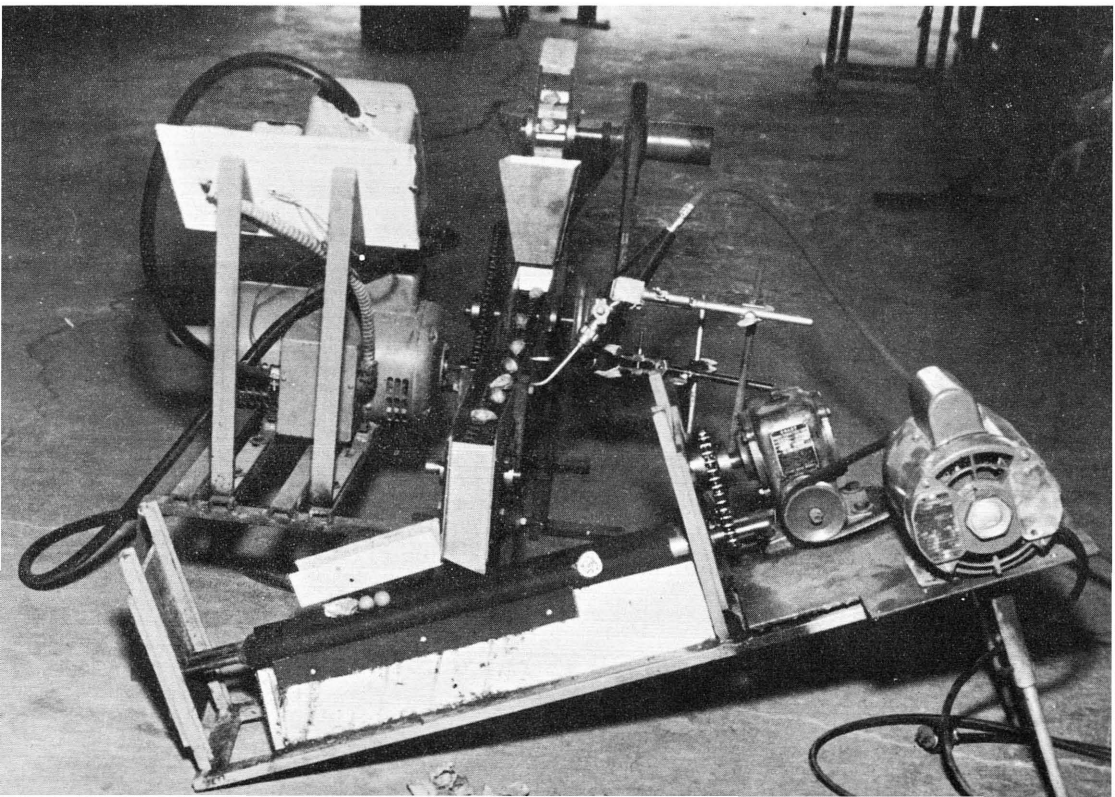

FIGURE 6. Unhusked berry resting on rollers.

the pairs was covered with Neoprene (Durometer 60), and the other, with Neoprene (dry cell). The remaining two pairs had radii of 0.75 inch each. The rollers were mounted on frames and were driven by an arrangement that permitted variable speed. Because a large percentage of the berries were crushed when husked by rollers with radii of 0.75 inch, experiments on the larger rollers were discontinued. Figure 5 shows the effect of roller speed on crushing percentage for the smaller rollers. Figure 7 shows the laboratory testing equipment used to obtain the results.

FIGURE 7. Laboratory husker.



During these tests it was observed that if the berries are allowed to fall freely, they will most likely fall sideways, as shown in figure 6. When this happens, husking generally proceeds without mishap, except for some conditions as discussed below.

However, the berries may sometimes fall on their pointed end and the rollers will get hold of the husk from the tip of the pointed end and crush the berries.

Various methods were tried in an attempt to reduce this damage. It was found that if a cut was introduced on the husk of a berry before the berry was dropped on the rollers, the cut on the husk would provide an escape for the berry, even if the berry fell tip-end first.

Various ways of introducing artificial cuts on the husks were investigated. It was found that small acetylene oxygen nozzles were the most satisfactory. The arrangement is shown in figure 7.

The average weight loss of hand-husking is about 10%, depending upon the dryness of the husk. The laboratory equipment without the precutting attachment showed an average weight loss of 30%. With the precutting attachment the weight loss was reduced to 20%.

It was pointed out that if berries are allowed to fall freely, they will most likely fall sideways, as shown in figure 6. Of the two possibilities shown in figure 6, position (6.a) is obviously the undesirable one. In order to husk a berry under position (6.a) it would be necessary to cause buckling of one side of the husk, which would be much more difficult than to simply fold the husk and to pull it away from the berry, as would be required under position (6.b).

Because a difference in frictional coefficients tends to make the berries rotate, and to change from position (6.a) to (6.b), rollers of different frictional coefficients were used in order to bring about instability in position (6.a).

DESIGN AND TESTING OF A PROTOTYPE HUSKER

From information gathered in laboratory tests a prototype poha berry husker was constructed. Figure 8 shows the husker with a feeder and a precutting attachment. Its frontal cover has been removed to show the inside of the roller-husker.

Figure 9 shows the side view of the machine and figure 10 shows the driving mechanism of the roller. Detailed drawings of the roller-husker are appended at the end of this bulletin. The rollers are driven by a $\frac{1}{4}$ -horse-power capacitor electric motor.

The prototype husker was tested in June, 1963, at the Niolopa Hawaiian Jams and Jellies Company, Hilo, Hawaii. Test results are summarized in table 1. The overall husking rate was 42.2 pounds per hour, which could be easily increased from 50% to 100% without overloading the rollers, by using a larger feeder and precutting attachment. The overall weight loss was 21.94%, which included the weight of the discarded husks.

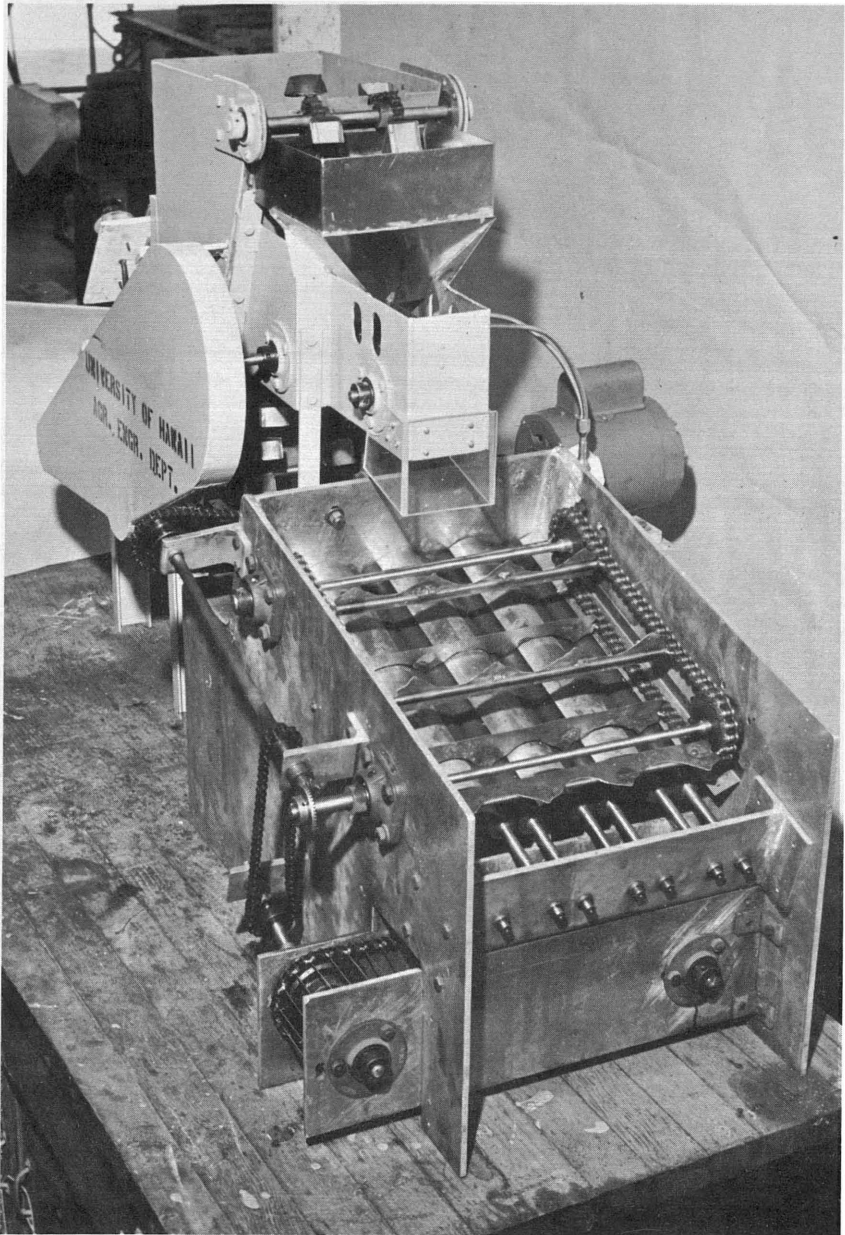

FIGURE 8. Laboratory husker with a feeder and a precutting attachment.

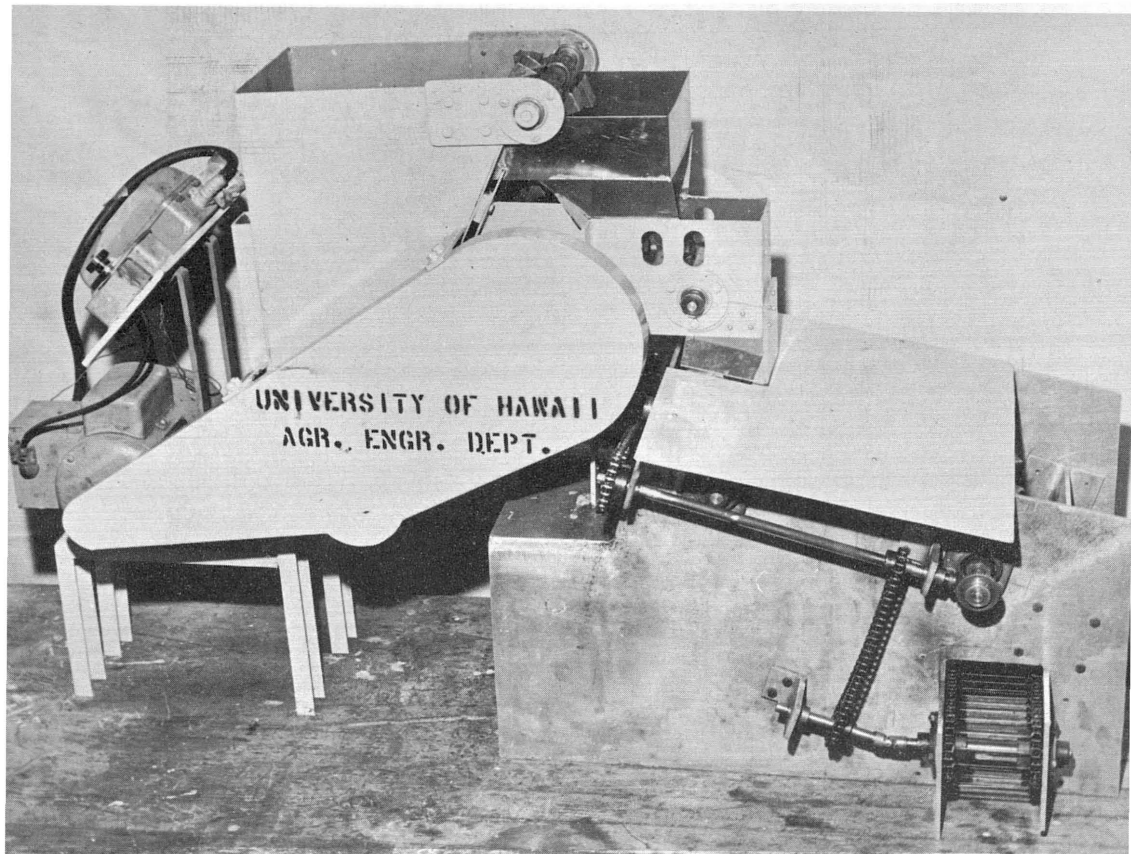

FIGURE 9. Side view of the laboratory husker.

In test number 5, the precutting attachment was inactivated. The weight loss was 32.5%, and clearly demonstrated the necessity of the precutting attachment.

In the prototype husker, two Size A oxygen-acetylene nozzles made by the Smith Welding Equipment Corporation were used to produce two narrow flames of about $2\frac{1}{2}$ inches in length. The valve stem used was model U600 by the same company.

Poha berries picked up by the small bucket-shaped feeder were dropped onto a metal conveyor, which was made by attaching stainless steel plates to an ASA No. 40 chain. The height of the two flames was adjusted in such a way that when the berries on the conveyor moved past the flames, the upper portion of the husk came into contact with the flames. A slight

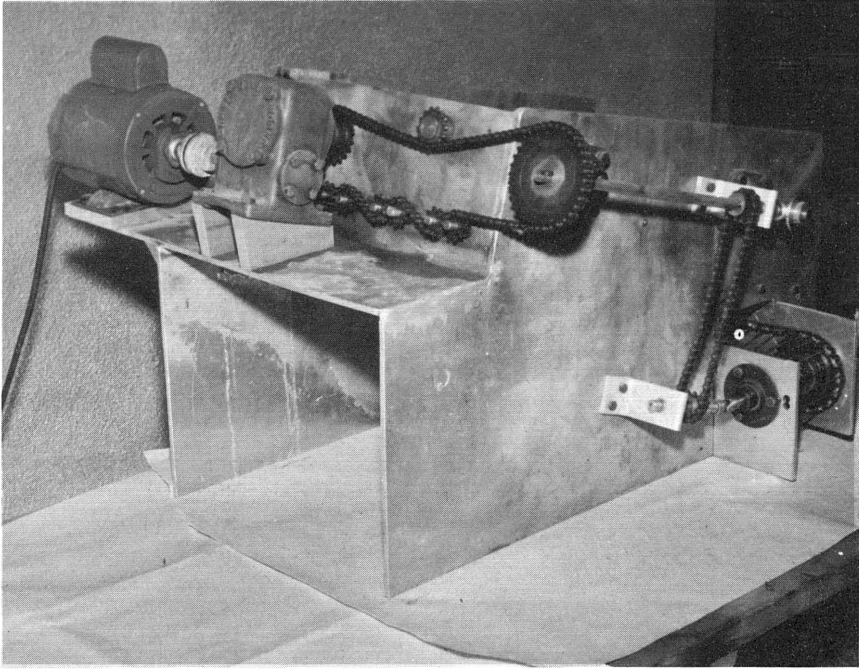

FIGURE 10. Prototype husker and its drive mechanism.

burning was thus introduced on the upper portions of the husks and provided a weakened spot through which the berries could escape when pressed.

It was found that two weak flames would do a better job than one strong flame. The distance between the two nozzles needs to be close. After several trial runs, the distance between the nozzles on the prototype husker was set at $1\frac{1}{2}$ inches.

The husk of poha berries varies in its moisture content. When harvested, the husk is green in color, relatively moist, and somewhat difficult to burn. After harvesting, the husk gradually dries up and burns easily.

To cope with this problem, the speed of the conveyor was made to be adjustable from 18 feet per minute to 25 feet per minute. The slower speed was used for moist husks.

To prevent the dry husk from overburning, the nozzle assembly was placed close to the drop-off point of the metal conveyor. Overburning of the dry husk left very little husk on the berry and therefore prevented the rollers from doing an effective husking job.

The performance of the prototype husker is satisfactory. It was noted, however, that usually about 5% of the berries would pass through the husker

TABLE 1. Field test results of prototype husker

TEST NO.	BEFORE HUSKING WEIGHT, POUNDS	AFTER HUSKING WEIGHT, POUNDS	PERCENT WEIGHT LOSS	HUSKING TIME, MINUTES
1	15¼	11¼	25.4%	25
2	16¼	13	22.4%	23
3	7¾	6 ¹ / ₁₆	21 %	12
4	40	31¼	21.9%	55
5*	20	13½	32.5%	27
6	21	17 ⁵ / ₁₆	19 %	29

*Pretcutting attachment not used.

without being husked. These berries must then be separated from the husked ones. Also, because the husks were burned, it was necessary to wash the husked berries.

Hand-husked berries are not entirely clean, either; the present practice is to wash the berries in screen-bottomed pans.

It is suggested that any commercial mechanical husker have a built-in screen conveyor to receive the berries, husked or not, and to carry them under water sprays which will wash them clean. The same conveyor could also carry the berries past an inspector so that the unhusked berries as well as the rotten berries could then be separated from the desirable berries.

SUMMARY

1. An analysis was made to determine the design criteria of a roller-type mechanical poha berry husker.
2. Laboratory experimental results indicated that rollers with a diameter of 0.625 inch, covered with Neoprene (Durometer 60) and Neoprene (dry cell), rotating opposite each other at 210 rpm to 250 rpm were effective in removing husks from poha berries.
3. A prototype husking machine was constructed and field-tested. The husking machine consisted of four pairs of rollers, described above, a feeder, and a pretcutting attachment.
4. The capacity of the prototype machine was 42 pounds per hour. Since the testing capacity was limited by the size of the feeder, it can be easily increased from 50% to 100% by increasing the size of the feeder. A properly designed machine with one worker can, therefore, replace five to six workers.
5. The overall weight loss of poha berries husked by this machine is 22%, which includes the weight of the discarded husks. The overall weight loss by hand-husking is 10%.

APPENDIX

82-S
Sept. 28, 1963
1" = 3"

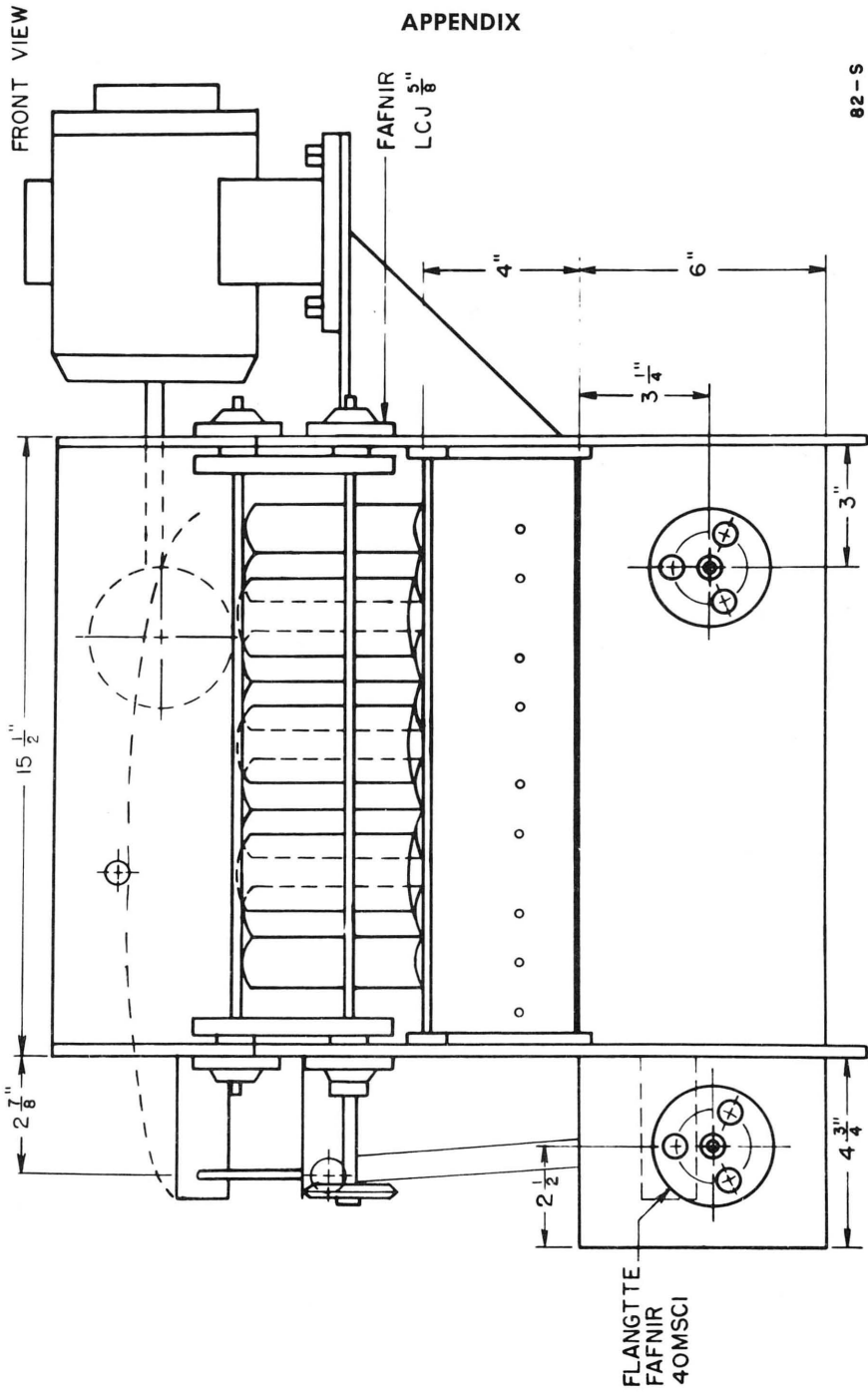

FIG. A-1. Dimensional drawing of mechanical potha berry husker. Front view.

LEFT SIDE VIEW

82-S

Sept. 28, 1963

1" = 3"

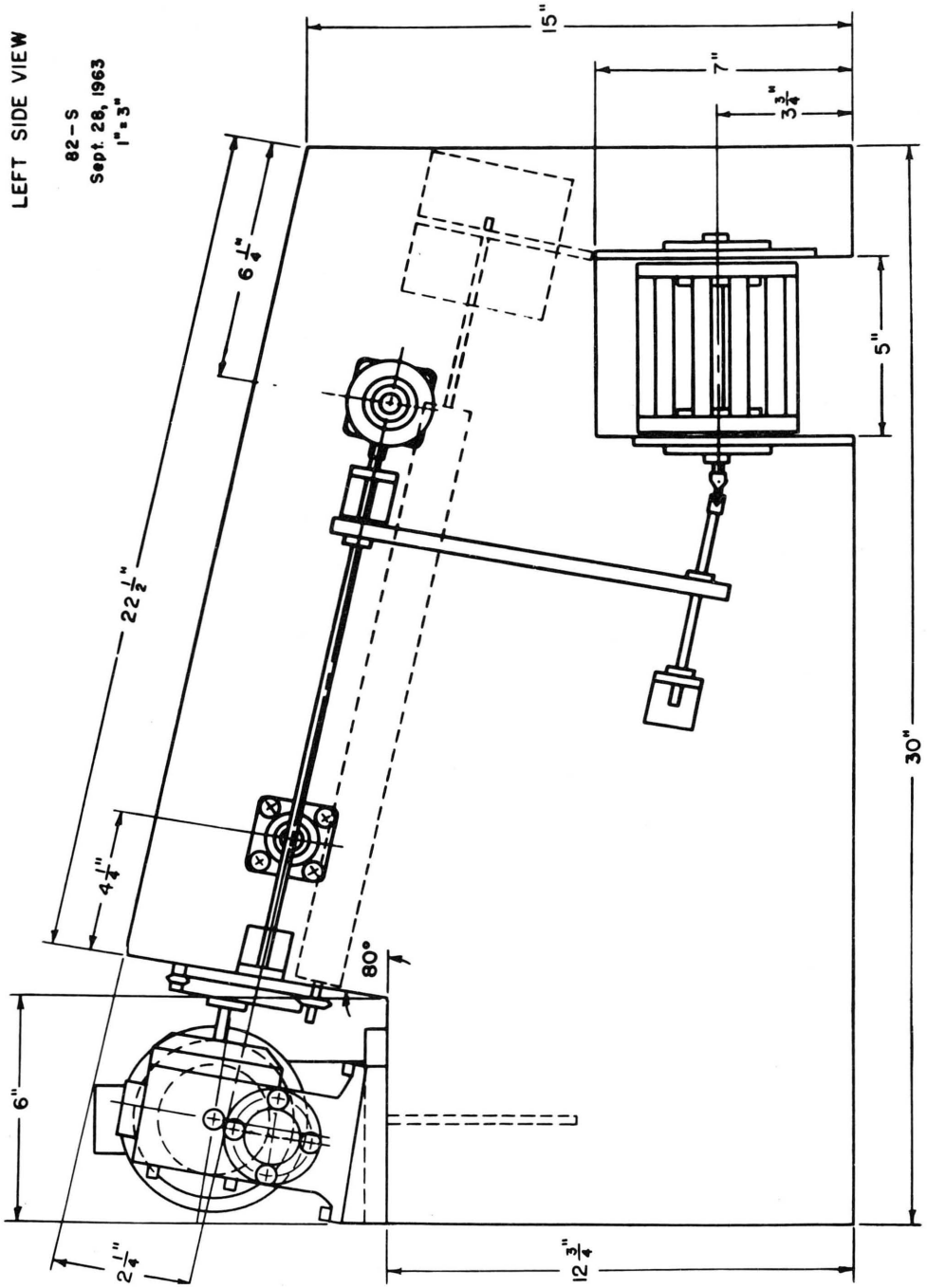

FIG. A-2. Dimensional drawing of mechanical polka berry husker. Side view.

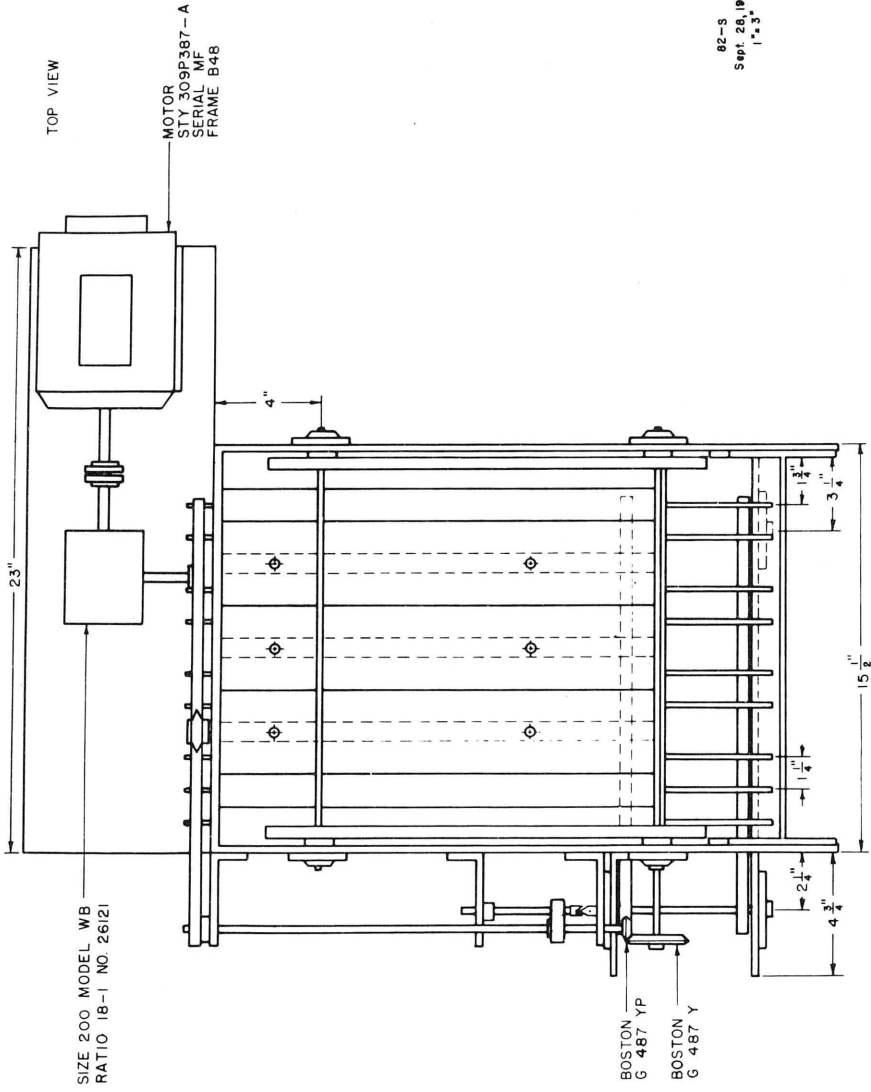

FIG. A-3. Dimensional drawing of mechanical poha berry husker. Top view.

REFERENCES

1. BROWN, FRANK L. 1931. ENGINEERING MECHANICS. Chapter VII. John Wiley & Sons, Inc., New York.
2. RICHEY, C. B. (Editor). 1961. AGRICULTURAL ENGINEERING HANDBOOK. McGraw-Hill Book Co., New York. Pp. 253-255.
3. WANG, JAW-KAI. 1963. DESIGN OF A GROUND BERRY HUSKING MACHINE. Trans. Amer. Soc. Agr. Engin. 6(4): 311-312.

**UNIVERSITY OF HAWAII
COLLEGE OF TROPICAL AGRICULTURE
HAWAII AGRICULTURAL EXPERIMENT STATION
HONOLULU, HAWAII**

THOMAS H. HAMILTON
President of the University

C. PEAIRS WILSON
Dean of the College and
Director of the Experiment Station

G. DONALD SHERMAN
Associate Director of the Experiment Station