

# SHORT CIRCUIT FAULT TRANSIENT STUDIES OF POWER DISTRIBUTION SYSTEMS INCLUDING DISPERSED GENERATION

G.B. Gharehpetian<sup>1</sup>, Farhad Shahnia<sup>2</sup>

<sup>1</sup>Faculty of Electrical Engineering, Amirkabir University of Technology, Tehran, Iran

<sup>2</sup>Eastern Azarbayjan Electric Power Distribution Company, Tabriz, Iran

<sup>1</sup>grptian@cic.aku.ac.ir, <sup>2</sup>shahnia@tabrizu.ac.ir

**Abstract-** Nowadays, there is a great interest in installation of dispersed generation systems in low voltage or medium voltage distribution systems, all over the world. Some standards suggest that all dispersed generation systems should be disconnected from the power system as an earth fault has occurred in the distribution system which can lead to an ineffective solution due to disconnection of a huge number of units. In this paper, the connection of dispersed generation systems to the power distribution system at short circuit faults are studied and the results of the connected or disconnected units are investigated. The simulations done with ATP-EMTP prove the capability of handling the power system stability with standard voltage and current characteristics when a fault has occurred in the power distribution system.

**Keywords-** Dispersed Generation, Power Distribution System, Short Circuits, Transients, Stability.

## I. INTRODUCTION

Nowadays, distributed generation (DG) applied on the distribution level has been a significant issue among distribution companies. DG is usually associated with wind power, photovoltaic cells and the other environmentally friendly energies. DG units are usually small scale generation units connected directly to the distribution network and feed neighborhood costumers. Meanwhile, deregulation of electric utilities has created a renewed interest in operating generators in parallel with the utility, where the penetration of DG units is expected to grow.

DG has great and enormous positive effects on the distribution system such as supporting the voltage in the network especially when located far from the feeding primary substation and in some cases, DG installation can avoid or postpone network investments. On the other hand, the high capacity installation of DG units is said to may conflict the operation of the system mainly since the DG units are designed as radial distribution systems. Two major problems of DG units may be the voltage and fault current levels and also the protection system operation during faults in the network.

Some national standards prescribe that DG units should be automatically disconnected from the distribution networks in case of any fault happening in the distribution system where the DG units are installed.

The operational requirements of the utility which justify the automatic disconnection of the DG units from the distribution network are as follows:

- Preserving the selective protection level of the network using overcurrent relays.
- The fault currents in the network interfacing synchronous generators and asynchronous generators of the installed DG units can trip the whole distribution network even where any fault has not occurred.
- The faults would be fed through the installed DG units in the network even if the main network switchgear are disconnected resulting in the fault level increase in the network.
- The accuracy of fault location estimation can decrease when connected DG units to the distribution network are fed the network.
- The safety of the utility personal could be in hazard when they are doing maintenance and repairs on the network with main switchgear disconnected but DG units feeding the network.

In this paper, the connection of DG units to the power distribution systems at short circuit faults is studied and the results of the connected or disconnected DG units are investigated. The simulations are done with ATP-EMTP software where prove the capability of handling the power system stability with standard voltage and current characteristics when a fault has occurred in the power distribution system with connected DG units in the network.

## II. PROTECTION CONFLICTS WITH DG

The presence of DG can cause various problems in the incorrect operation of system protection. Conflicts between DG and protection schemes are usually related to:

- Increase in short circuit currents
- Effectiveness of line reclosing after a fault
- Protection system coordination

### Overcurrent protection

Theoretical studies of the impact of DG on the network faults current indicate that DG may invalidate overcurrent protection. DG may affect the operation of existing distribution networks by providing flows of fault currents which were not expected when the protection was originally designed. In practice, the presence of DG may result in increased fault currents which depend on capacity, penetration, technology, interface of the DG, and system voltage prior to the fault.

### Line reclosing after a fault

Automatic reclosing is very common and effective method of temporary fault clearing especially in distribution networks which have a large number of overhead lines and most faults on overhead lines are temporary, therefore, power can be restored immediately using an autorecloser. On a radial system, fault clearing requires the opening of only one device because there is only one source contributing current to the fault. In contrast, meshed transmission systems require breakers at both ends of a faulted line to open. When DG is present, there are multiple sources and opening only the utility breaker does not guarantee that the fault will clear promptly. Therefore, DG will be required to disconnect from the system when a fault is suspected so that the system. But DGs seem to be rather incompatible especially with high speed reclosing which does not leave enough time to disconnect the DGs from the network. In this case DG units may sustain the voltage and fault arc, preventing successful reclosing in case of temporary faults.

### Protective device coordination

Normally, due to the protection coordination of the network at design period, only the faulted part of the system is isolated at a fault which can be negatively affected by the presence of DG.

### III. MAIN FEATURES OF DG UNITS

It is of great importance to study the load flow and fault transients of the distribution networks with installed DG units. These studies can help us in studying the possibility of handling and controlling the connected DG units to the distribution network when

- The short circuit fault has occurred in high voltage networks.
- The short circuit fault has occurred in the other feeders (feeders without installed DGs) of the low voltage or medium voltage networks.
- The short circuit fault has occurred in the faulty feeders (feeders with installed DGs) of the low voltage or medium voltage networks only if the faults would be cleared with the autorecloser operation of the network.

Achieving (a) and (b) is possible if the fault duration is less than its clearance time which would prevent any instability of the synchronous and asynchronous generators. For achieving this purpose, it is essential to:

- Prevent the synchronous generators to run out of their synchronism.

- Disconnect the DG units with asynchronous generators on the conditions of their overspeed or when the short circuit remains on the network.
- Keep the increased fault level of the system within the limited values of low voltage or medium voltage networks.
- Setting the overcurrent relays of the radial distribution systems with installed DG units appropriately. For this purpose, the whole capacity of the installed DG units should be less than a limit and should also be connected to medium voltage networks. In addition, the asynchronous generators should also be non self excited type whose short circuit fault duration is shorter.

Achieving (c) seems impossible in the case of utilizing synchronous generators for DG units since it is necessary to study the rate of network voltage variations for setting the operation time of the autorecloser. The synchronous generators are accelerated during faults and reclosing times whose speed reduces to normal after the line is reclosed which depends on terminal voltage, electromagnetic torque, constant inertia, current absorption ....

### IV. STUDY CASE AND SIMULATION RESULTS

The schematic diagram of a 20 kV medium voltage radial power distribution system with two installed DG units is shown in Fig. 1. The distribution system is fed through a 132 kV high voltage external grid. The current and voltage waveforms of the system are studied and investigated for short circuit fault transients in different feeders of the 20 kV power system. The simulations are done with ATP-EMTP software assuming the faults starting at 0.1 sec. and all the results are studied at 0.05-0.2 sec. for its transient characteristics.

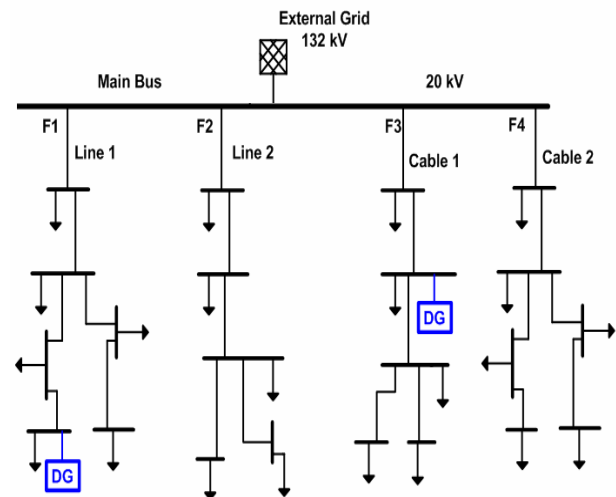

Fig. 1. Single line diagram of the power distribution system with installed DGs.

The short circuit current waveform of the distribution system with installed or non installed DG units is shown in Fig. 2 which proves that the fault level increases when the DG unit is still connected to a faulty feeder. However, it is also proved that the fault level is the same for the feeders with no DG units installed in the power system or DG units installed in non faulty feeders.

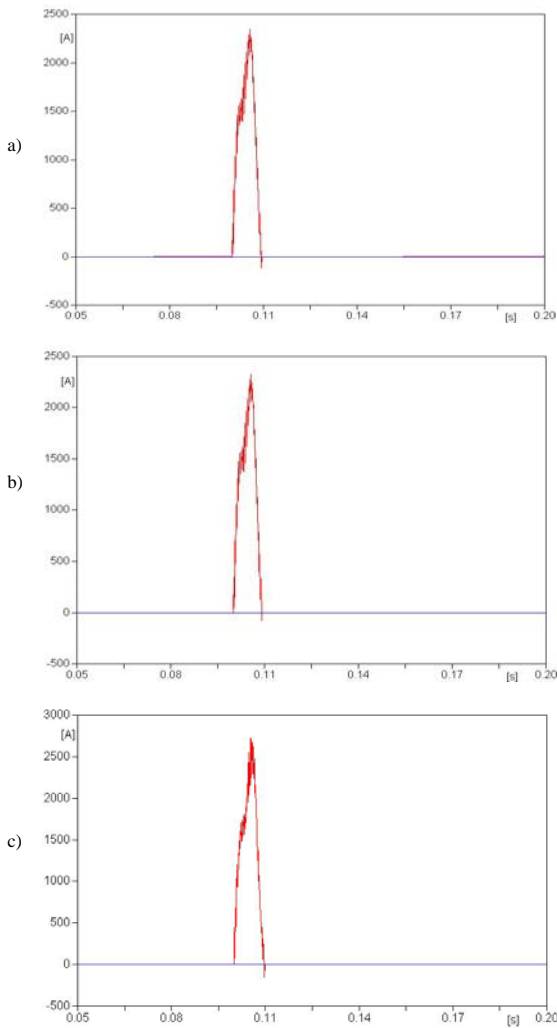

Fig. 2. Short circuit current waveforms at a faulty feeder when:  
 a) No DG units are installed in the power system.  
 b) The DG unit is installed in non faulty feeder.  
 c) The DG unit is installed in the faulty feeder.

The voltage waveforms of the 20 kV main bus connected to the 132 kV external grid are also shown in Fig. 3 for the different conditions of DG units installed in the faulty or non faulty feeders of power distribution system. Studying Fig. 3 proves that the voltage of the 20 kV main bus increases when a fault occurs on a feeder with installed DG units. However, it is almost the same for the systems without installed DG units or DG units installed on non faulty feeders.

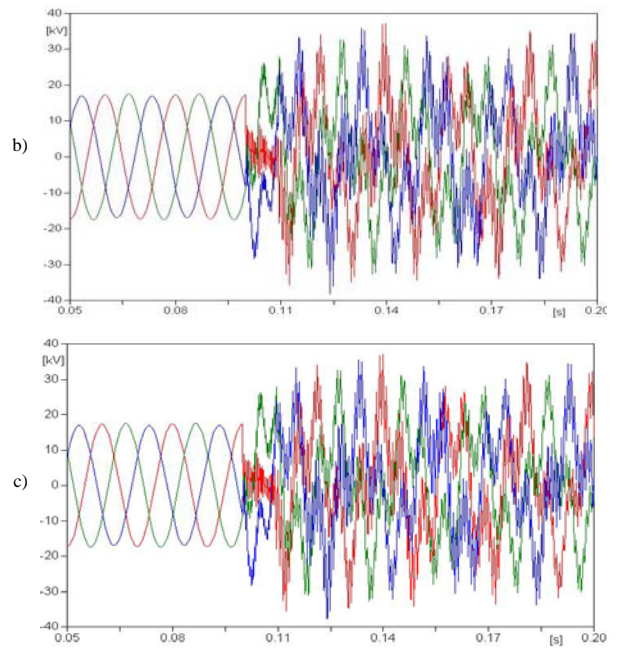
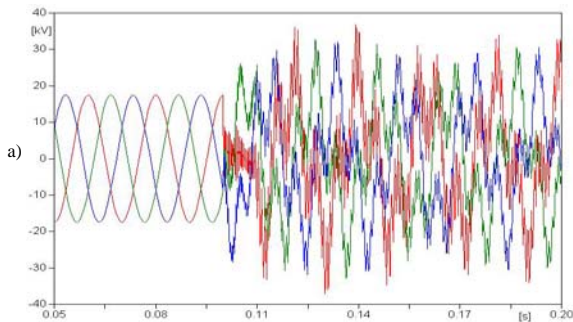

Fig. 3. Voltage waveform of 20 kV bus at a short circuit fault when:  
 a) No DG units are installed in the power system.  
 b) The DG unit is installed in non faulty feeder.  
 c) The DG unit is installed in the faulty feeder.

The current waveforms of the 132 kV external grid at a short circuit fault on the 20 kV system are shown in Fig. 4 for different installation conditions of DG units. The simulation results prove that little disturbances are applied to the current waveforms of the 132 kV system since, the short circuit current is fed through the DG unit to some extent.

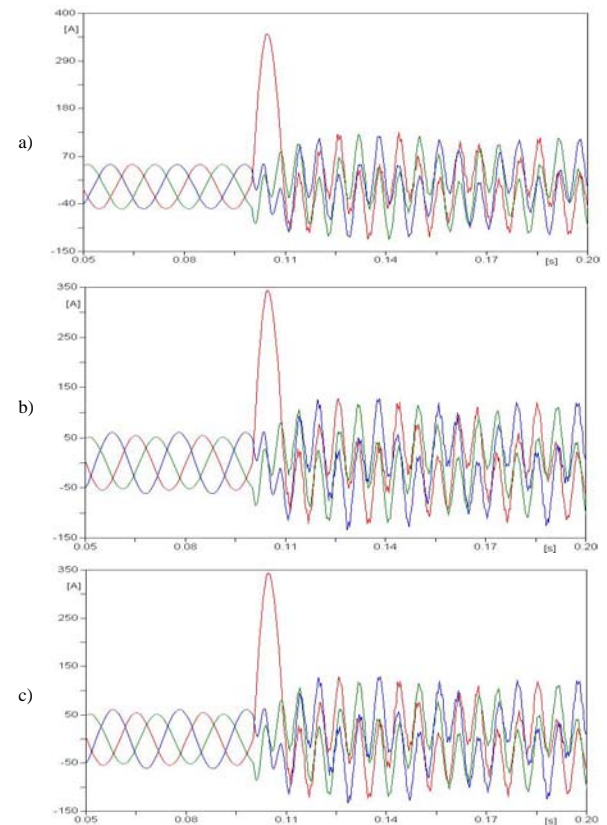

Fig. 4. Current waveforms of 132 kV bus at a short circuit fault when:  
 a) No DG units are installed in the power system.  
 b) DG unit is installed in non faulty feeder.  
 c) The DG unit is installed in the faulty feeder.

The current waveforms of different feeders of the 20 kV distribution system are shown in Figures 5 and 6 for different installation conditions of DG units. Investigating the simulation results prove that the current of the faulty feeder with installed DG unit is almost the same as when no DG unit is installed at that feeder or it is installed on the non faulty feeder.

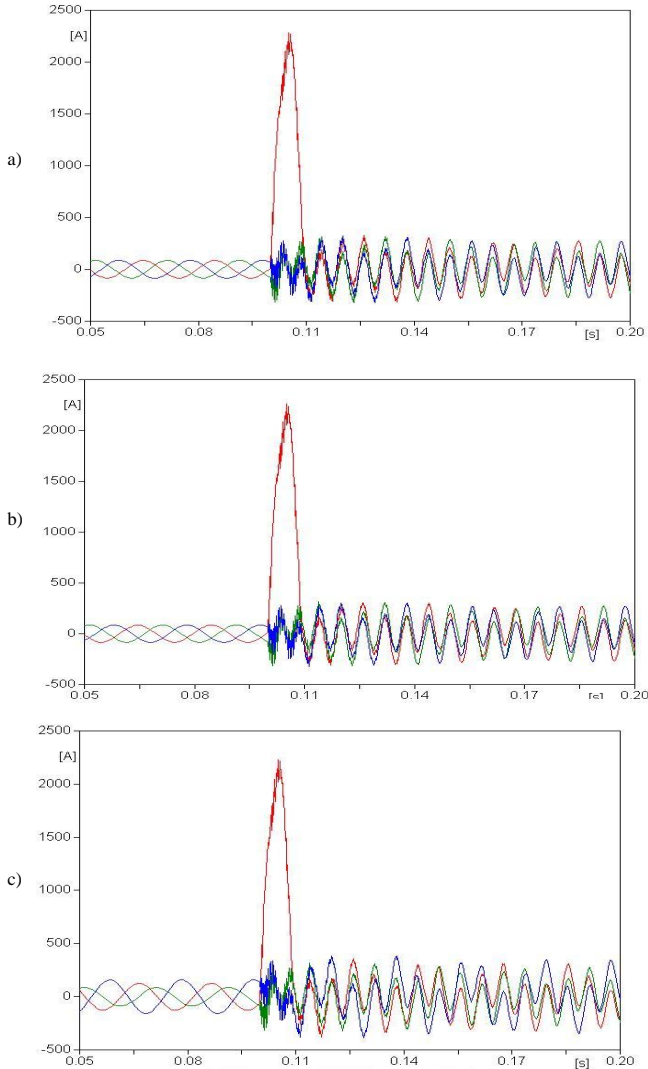

Fig. 5. Current waveforms of faulty feeder of 20 kV system at a short circuit fault when:

- a) No DG units are installed in the power system.
- b) The DG unit is installed in non faulty feeder.
- c) The DG unit is installed in the faulty feeder.

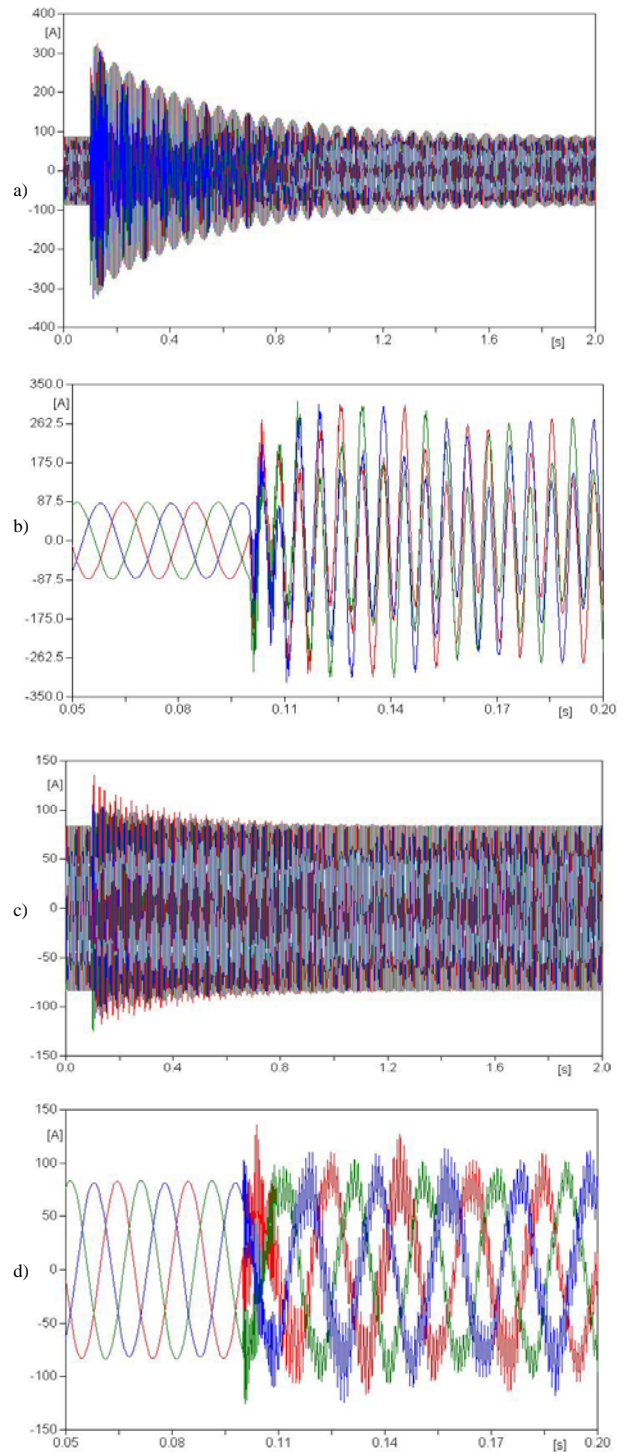

Fig. 6. Current waveforms of non faulty feeder of 20 kV system at a short circuit fault which is the same whether DG unit are installed or not installed at:

- a) Overhead line feeders.
- b) Underground cable feeders.

The current and voltage waveforms of the power distribution system loads are shown in Fig. 7 at a short circuit fault for different connection and disconnection conditions of DG units. Studying these waveforms, it is proved that the current and voltage waveforms of the load for the connection and disconnection conditions of DG units to the faulty feeders are the same.

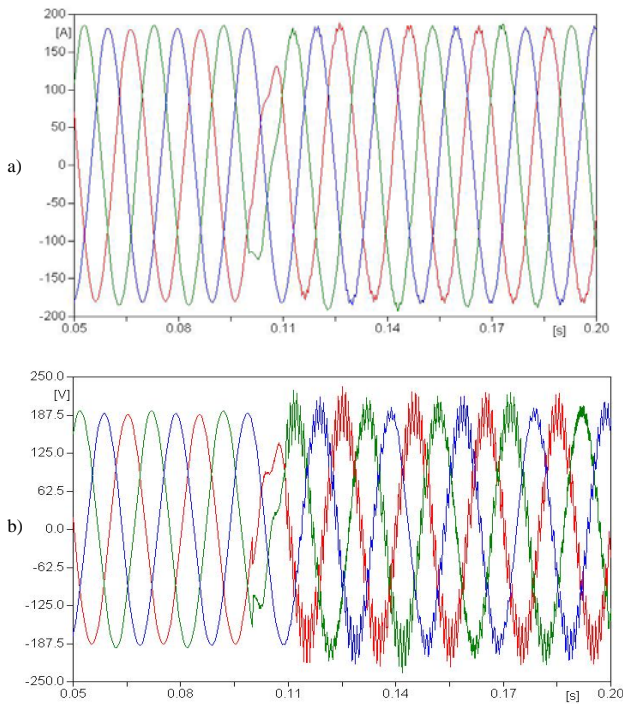

Fig. 7. The same current (a) and voltage (b) waveforms of the loads for the faulty distribution system with installed or non installed DG units in different feeders.

According to the DG unit installation points on part III and studying the simulation results, it can be concluded that for the correct protection characteristics of the system, i.e. correct selection of settings of different relays in the power distribution system and the generators of DG units, the fault level of the faulty feeders with connected DG units is almost the same with the disconnect DG condition. This can lead to still being connected DG unit condition in the distribution system at fault situations even if the DG unit is in the faulty feeder. Therefore, it is necessary to discuss the standards of DG unit installations to the power distribution systems.

## V. CONCLUSION

Nowadays, there is a great interest in installation of DG units to distribution systems. Besides, all the great benefits of DGs, some incompatibility problems between the DG units and the protection system of the networks has made some national standards to disconnect all the DG units connected to the network when a fault is happened anywhere in that distribution system. However, this may not always be possible or desired, in particular when DG penetration is high in a distribution network. In this paper, the connection of DG units with different structures to the power networks at short circuit faults was studied and the results of the connected or disconnected DG units at faulty times were investigated. The simulations done with ATP-EMTP prove the capability of handling the power system stability with standard voltage and current characteristics when a fault has occurred in the power distribution system.

## VI. REFERENCES

- [1] T. Tran-Quoc, C. Andrieu, N. Hadjsaid, "Technical impacts of small distributed generation units on LV networks", *IEEE Power Engineering Society General Meeting*, 2003, Vol. 4, July 2003.
- [2] J. Dolezal, P. Santarius, J. Tlustý, V. Valouch, F. Vybíralík, "The effects of dispersed generation on power quality in distribution system", *CIGRE/IEEE Int. Symp. on Quality and Security of Electric Power Delivery Systems*, pp. 204-207, Oct. 2003.
- [3] B. Maurhoff, G. Wood, "Dispersed generation, reduce power costs and improve service reliability", *Rural Electric Power Conference*, pp. C5/1-C5/7, May 2000.
- [4] F. M. Gatta, F. Iliceto, S. Lauria, P. Masato, "Modelling and computer simulation of dispersed generation in distribution networks, Measures to prevent disconnection during system disturbances", *IEEE PowerTech Conf.*, June 2003, Italy.
- [5] N. Hadjsaid, J.F. Canard, F. Dumas, "Dispersed generation impact on distribution networks", *IEEE Int. Conf. on Computer Applications in Power*, Vol. 12, No. 2, pp. 22-28, April 1999.
- [6] A. Agustoni, M. Brenna, R. Faranda, E. Tironi, C. Pincella, G. Simioli, "Constraints for the interconnection of distributed generation in radial distribution systems", *IEEE 10<sup>th</sup> Int. Conf. on Harmonics and Quality of Power*, Vol. 1, pp. 310-315, Oct. 2002.
- [7] S.A. Papanthassiou, N.D. Hatziargyriou, "Technical requirements for the connection of dispersed generation to the grid", *IEEE Power Engineering Society Summer Meeting*, Vol. 2, pp. 749-754, July 2001.
- [8] D. Ardito, S. Conti, N. Messina, S. Nicotra, "Impact of distribution generation on Italian distribution network protection", *5<sup>th</sup> WSEAS Int. Conf. on Power Systems and Electromagnetic Compatibility*, pp. 478-482, August 2005.
- [9] K. Maki, S. Repo, P. Jarventausta, "Blinding of feeder protection caused by distributed generation in distribution network", *5<sup>th</sup> WSEAS Int. Conf. on Power Systems and Electromagnetic Compatibility*, pp. 377-382, August 2005.