

Robust Passivity Analysis and Design for Chemical Processes

Huaizhong Li, Peter L. Lee* and Parisa A. Bahri†
School of Engineering
Murdoch University
Perth, WA 6150, Australia

Abstract

In this paper, a new approach is developed for robust control of nonlinear chemical processes. The methodology proposed is based on passivity theory. Uncertainty and perturbations are taken into account in the stability analysis and controller synthesis such that the resulting closed-loop system can achieve better robustness and performance. The suggested passivity framework can deal with a large class of uncertainties and perturbations in chemical processes.

Keywords

Process control, Passivity, Robust control

Introduction

The effective control of process plants using high performance control systems must consider both stability and performance in the face of uncertainty - the so called robust control problem. Many modern robust control methods are based on finite gain (H_∞) control theory. However, finite gain designs can be overly conservative for some uncertain systems because it ignores phase information of the feedback systems (Sakamoto and Suzuki, 1996).

Recent work on robust control design has employed the concept of passivity (Bao et al., 1999). Often robust stability of a system can be determined by evaluating passivity of a subsystem. Many uncertain systems can be converted into equivalent interconnected feedback systems which consist of a linear block and possibly a nonlinear and/or time-varying block. By studying the passivity of the interconnected systems, sufficient stability conditions can be derived for the original uncertain systems. Specifically, if the linear block is strictly passive and the nonlinear block is passive, then the original uncertain system is robustly stable.

In general, the nonlinear block of the interconnected system can be classified into four types: 1. Non-passive; 2. Near-passive; 3. Passive; and 4. Over-passive. It is very difficult to guarantee robust stability and robust performance if the nonlinear block is strictly non-passive. In order to apply passivity theory, it is necessary that the nonlinear is at least near passive.

However, it is not always straightforward or advantageous to combine all of the uncertainties into the nonlinear block. It is sometimes desired to leave some bounded uncertainties, for example, linearization errors, to the linear block such that the nonlinear block is passive or near-passive. It may be relatively simple to guarantee that the linear block with the bounded uncertainties is robust strictly passive.

This paper deals with robust stability and control design using the passivity approach. Near-passive and

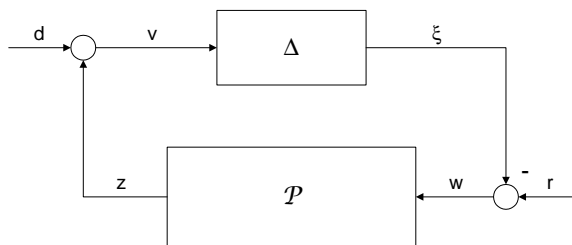

Figure 1: Interconnected feedback system.

over-passive uncertain blocks are considered for the nonlinear block, while the linear block may also contain uncertainty. A methodology for robust stability criteria and controller synthesis is proposed. The results presented in this work provide better robust stability and system performance for those systems that have an over-passive nonlinear block or contain other uncertainties in the linear block. Two examples are presented to highlight the benefits of the proposed approach.

Preliminaries

Consider the feedback system depicted in Figure 1, where \mathcal{P} is a linear system and Δ represents a nonlinear/time-varying uncertainty.

The passivity concept is closely related to energy in an interconnected feedback system. For stability analysis, inputs r and d can be set to zero. For such a system, stability results can be established by observing energy consumption in the feedback loop. Let us assume that there is an abnormal energy burst occurring in the feedback loop. If the uncertain block Δ is passive, then at least this block does not inject energy into the feedback loop. In addition, if the linear block \mathcal{P} is strictly passive, it means that this block absorbs energy. As there is no energy injection into the feedback loop, it is expected that energy in the feedback loop will be finally consumed by blocks Δ and \mathcal{P} , and hence stability is maintained. Technical details about the passivity approach can be found in Desoer and Vidyasagar (1975).

In the sequence, we call Δ block near passive if it is not

*plee@central.murdoch.edu.au. Corresponding author

†parisa@eng.murdoch.edu.au

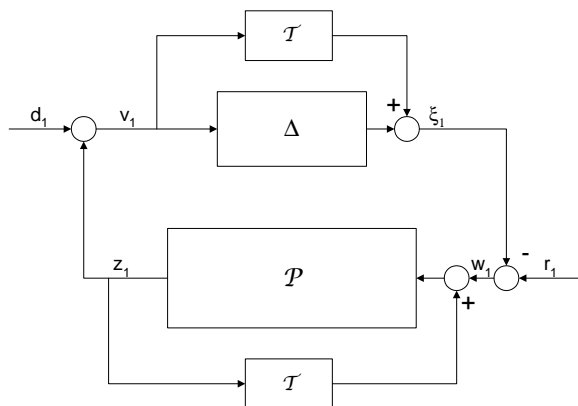

Figure 2: Transformed feedback system.

passive, but is close to being passive. Similarly, we call Δ over passive if it remains passive even under certain additive perturbation.

When Δ is near passive, transforms (Desoer and Vidyasagar, 1975; Xie et al., 1998) can be applied on the interconnected system to render the transformed Δ block passive, as depicted in Figure 2. Similarly, transforms can also be applied to reduce conservatism if Δ is over passive. In both cases, stability analysis are performed on the feedback system with two transformed blocks.

Methodology

In general, there is no unique way to find the transform \mathcal{T} . If Δ is linear time-invariant and near passive, then the easiest way to find \mathcal{T} is to use the passivity index $v(\Delta)$ (Bao et al., 1999) such that $\mathcal{T} = v(\Delta)I$ and $\mathcal{T} + \Delta$ is passive. If Δ is over passive, then it is always possible to set $\mathcal{T} = \beta I$ where β can be any scalar such that $\mathcal{T} + \Delta$ is still passive. A general form for \mathcal{T} when Δ is over passive can be found in Xie et al. (1998).

Once the transformed Δ block is rendered passive, a controller can be synthesized to render the other transformed block strictly passive.

A nonlinear chemical process can be represented by the diagram in Figure 3, where Δ_1 is generally used to represent the output sensor errors or neglected high frequency dynamics for the process, \mathcal{P}_p is the linearized model for the process at a specific operating point, and K is a controller. However, due to nonlinearity and unknown perturbations, a better model for the process may be $\mathcal{P}_p(\Delta_2)$, where Δ_2 represents all of the uncertainties which are not absorbed by Δ_1 . Note that Δ_2 can always be set to zero if the linearized model \mathcal{P}_p is relatively accurate. In this case, further constraints can be manually imposed on Δ_1 to cope with the influence of omitting Δ_2 (Bao et al., 1999). It can be viewed as a special case under the framework of Figure 3.

For stability analysis, it is assumed that $r(t) = 0$. It

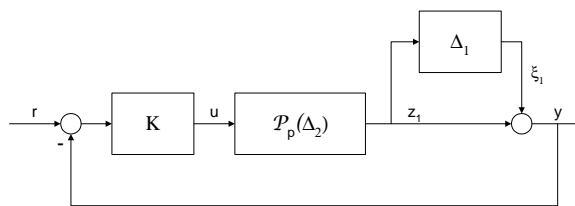

Figure 3: Diagram of a typical chemical process.

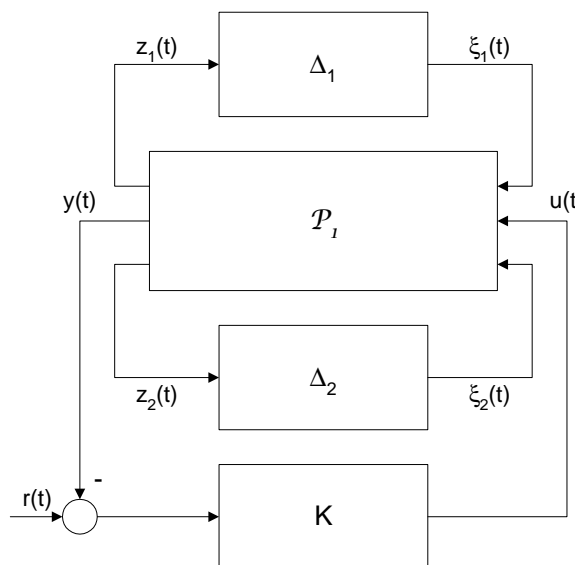

Figure 4: System diagram after 'pulled out' uncertainty.

is easy to check that for the special case $\Delta_2 = 0$, Figure 3 is equivalent to Figure 1 with $\Delta = \Delta_1$ and

$$\mathcal{P} = -\mathcal{P}_p K (I + \mathcal{P}_p K)^{-1}.$$

In general, the uncertainties Δ_1 and Δ_2 can be 'pulled out' to form an interconnected feedback system (see, for examples, Zhou et al., 1996), as depicted in Figure 4. We use operator matrix \mathcal{P}_1 to denote the remaining linear system after 'pulled out' uncertainties.

If Δ_1 is passive, a controller can be synthesized for the low half part with input $\xi_1(t)$ and output $z_1(t)$ to render it robustly strictly passive. The same controller also guarantees that the closed-loop system in Figure 3 is robustly stable.

If Δ_1 is near passive or over passive, a transform \mathcal{T} can be applied to Δ_1 and the low half part in Figure 3, as shown in Figure 5. Note that \mathcal{T} is set to $\mathcal{T} = \beta I$ for both near passive and over passive in this paper, and $\beta \geq v(\Delta_1)$ for the near passive case.

The transformed feedback system can be viewed as an interconnection of two transformed blocks, namely, 'Passive Uncertainty' block with input $z(t)$ and output $\xi(t)$ and 'System' block with input $\xi(t)$ and output $z(t)$, as

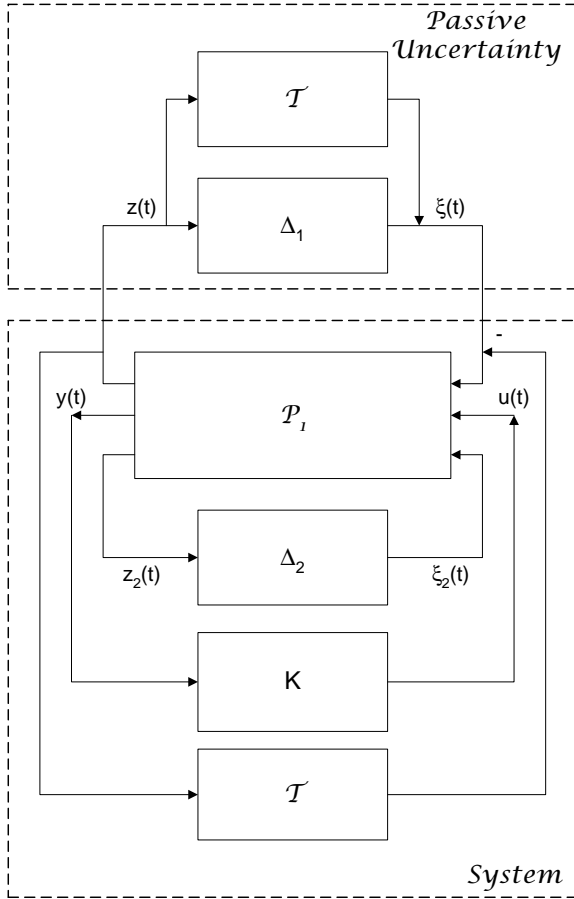

Figure 5: Transformed feedback system.

shown in Figure 5. K only needs to render the ‘System’ block robustly strictly passive.

The ‘System’ block can be described in the following state-space form:

$$\begin{aligned}
 \dot{x}(t) &= A(\beta)x(t) + B(\beta)u(t) + H_1\xi(t) + H_2\xi_2(t) \\
 y(t) &= C(\beta)x(t) + D(\beta)\xi(t) \\
 z(t) &= E_{11}x(t) + E_{12}u(t) + E_{13}\xi(t) \\
 z_2(t) &= E_{21}x(t) + E_{22}u(t) + E_{23}\xi(t)
 \end{aligned} \tag{1}$$

where $x(t) \in \mathbb{R}^n$ is the state, $y(t) \in \mathbb{R}^m$ is the measured output of the process, $u(t) \in \mathbb{R}^r$ is the manipulated input to the process. Vectors $\xi(t)$ and $z(t)$ can be viewed as the input and output of the ‘System’ block. Mapping $z_2(t) \rightarrow \xi_2(t)$ describes the uncertainty Δ_2 . This mapping can be very general, for example, it can be represented using integral quadratic constraints (IQCs) (see Boyd et al., 1994, for details). It has been shown that time delay uncertainties in systems can be represented by IQCs (see Xie et al., 1998, for details). However, to represent the linearization errors for a chemical process, it is often sufficient to set $E_{22} = 0$, $E_{23} = 0$ and $\xi_2(t) = \Delta_2(t)z_2(t)$ where $\|\Delta_2(t)\|_\infty \leq 1$.

β is a constant scalar. Although β can be pre-selected

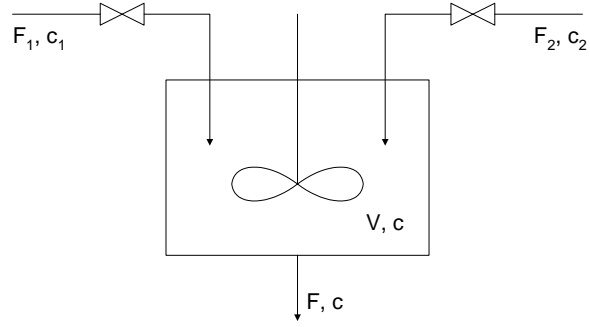

Figure 6: A mixing system.

based on the passivity index, we intentionally leave it intact as a design parameter. A β dependent controller can be synthesized, and then an iterative procedure or quasi-convex optimization can be applied to find the sub-optimal β which preserves the passive property of the ‘Passive Uncertainty’ block while achieving the best performance for the closed-loop system.

Based on the discussion above, we arrive at the following result:

Theorem 1 *If there exists a controller $u = Ky$ which renders system (1) robustly strictly passive, then the same controller guarantees that the closed-loop system shown in Figure 3 is robustly stable.*

Results are available in the literature to synthesize controller $u = Ky$ such that system (1) is robustly strictly passive. We omit the details in this paper due to page limitations. The interested readers may refer to Xie and Soh (1995) and the references therein.

Justification in Chemical Processes

In this section, we consider two examples. The main purpose of this section is to justify the framework proposed above for chemical processes. The details of the two examples are deleted for clarity.

The first example is a mixing system adopted from Bao et al. (1999). The well-stirred tank is fed with two inlet flows with flowrates $F_1(t)$ and $F_2(t)$. Both inlet flows contain the same dissolved material with concentrations c_1 and c_2 respectively. The outlet flowrate is $F(t)$. $F_1(t)$ and $F_2(t)$ are manipulated to control both $F(t)$ and the outlet concentration $c(t)$.

It was assumed in Bao et al. (1999) that inlet concentration disturbances cause the nominal plant transfer matrix $\hat{P}(s)$ to be shifted to $P(s)$. It was shown that the control problem can be described by Figure 3 with a near passive $\Delta_1(s) = (P(s) - \hat{P}(s))\hat{P}^{-1}(s)$ and $\mathcal{P}_p(\Delta_2) = \hat{P}(s)$. Following the settings in Bao et al. (1999), it is straightforward to verify that the feedback system in Bao et al. (1999) is equivalent to Figure 5 with $E_{13} = 0$, $E_{21} = 0$, $E_{22} = 0$ and $E_{23} = 0$ in (1). As (1)

is reduced to a linear system with no uncertainty in this case, standard passivity synthesis procedure can be applied to (1) to design the controller $u = Ky$.

It is also easy to show that $\Delta_1(s) = (P(s) - \hat{P}(s))\hat{P}^{-1}(s)$ can be over passive under different inlet concentration disturbances.

Next, we consider the stability problem of a CSTR. The component and energy balances for a CSTR with jacket cooling and first order irreversible exothermic reaction $A \rightarrow B$ are:

$$\begin{aligned}\frac{dC}{dt} &= \frac{F}{V}(C_0 - C) - kC \\ \frac{dT}{dt} &= \frac{F}{V}(T_0 - T) + \frac{\Delta H}{\rho c_p}kC - \frac{UA_r}{V\rho c_p}(T - T_C)\end{aligned}$$

where V is tank volume, F is feed flowrate, C_0 is feed concentration, C is outlet concentration, V is heat transfer coefficient, ρ is density, c_p is specific heat, T is reactor temperature, T_0 is feed temperature, ΔH is exothermic heat of reaction, U is heat transfer coefficient, A_r is heat transfer area from jacket to reactor, and T_C is cooling water temperature. k is defined by Arrhenius relation $k = k_0 e^{-\frac{E}{RT}}$ where k_0 is a rate coefficient factor, E/R is a activation energy factor. The measured variables are outlet concentration C and reactor temperature T , and the manipulated variables are feed flowrate F and cooling water temperature T_C .

The component and energy balance equations are linearized at a specific operating point to obtain two linear differential equations. If there is no feed perturbation, then linearization errors for the two balance equations depend on the state variables C and T only. It was shown in Doyle III et al. (1989) that if the linearization errors are conic-sector bounded, then the process description can be given by

$$\begin{aligned}\dot{x}(t) &= (A + \Delta_2 A_1)x(t) + Bu(t) \\ z_1(t) &= Cx(t)\end{aligned}$$

where Δ_2 is a bounded matrix.

However, the above plant description is obtained by assuming that the measurements are perfect. The measurement errors may be not significant when the process is operating at steady state. However, the instrument measurement response can often be important in the overall system response in the transition period (Mylroï and Calvert, 1986), or when the process is operating under the influence of uncertainty and perturbations. Therefore, the true measured output $y(t)$ is not identical to $z_1(t)$ in the above process description.

For simplicity, it is assumed that both temperature and concentration measurements can be represented by first-order lag models $1/(\tau_T s + 1)$ and $1/(\tau_C s + 1)$ where τ_T and τ_C are time constants which may change due to the variations in the unit inputs (Mylroï and Calvert, 1986). Therefore, the measured output is

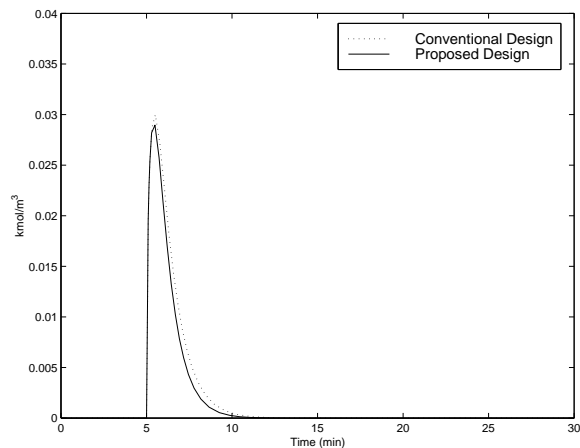

Figure 7: Control errors of outlet concentration for the mixing system.

$y = \text{diag}\{1/(\tau_T s + 1), 1/(\tau_C s + 1)\}z_1$. In the framework of Figure 3, this leads to an uncertain $\Delta_1 = \text{diag}\{-\tau_T s/(\tau_T s + 1), -\tau_C s/(\tau_C s + 1)\}$. It can be easily verified that Δ_1 is a near passive block and the passive index $v(\Delta_1) = 1$. Similarly, it is straightforward to see that the CSTR case fits into the framework of Figure 5 with $\beta = 1$, $E_{12} = 0$, $E_{13} = 0$, $E_{22} = 0$ and $E_{23} = 0$. These four matrices can be non-zero, for example, if there is a disturbance on the feed flowrate F .

Furthermore, it is possible to convert a multi-model control problem for multi-unit chemical processes in Lee et al. (2000) into a passivity framework shown in Figure 5. The passivity based multi-model approach will be addressed in a subsequent paper.

Illustrative Examples

We again consider the stability problem of the two examples mentioned above.

The first example verifies that over passive uncertainty needs to be properly addressed in order to reduce conservatism. This example takes the mixing system discussed in Bao et al. (1999). Differing slightly from (Bao et al., 1999), it is assumed that the $c_1(t)$ changes from 0.5 kmol/m^3 to 1.0 kmol/m^3 while $c_2(t)$ changes from 2.0 kmol/m^3 to 3.0 kmol/m^3 . Rest of the values follow exactly as those in (Bao et al., 1999). Following the same procedure, it is easy to verify that Δ_1 block is over passive. Two passivity based designs were carried out. As Δ_1 is already passive, design based on conventional passivity approach only renders the nominal system $\hat{P}(s)$ strictly passive. Design based on the proposed framework first renders $\Delta_1(s)$ passive by transform βI where β is negative, then a controller is synthesized to render the 'System' block strictly passive.

It is also assumed that at the 5th minute both c_1 and c_2 change simultaneously, c_1 decreases from 1 kmol/m^3

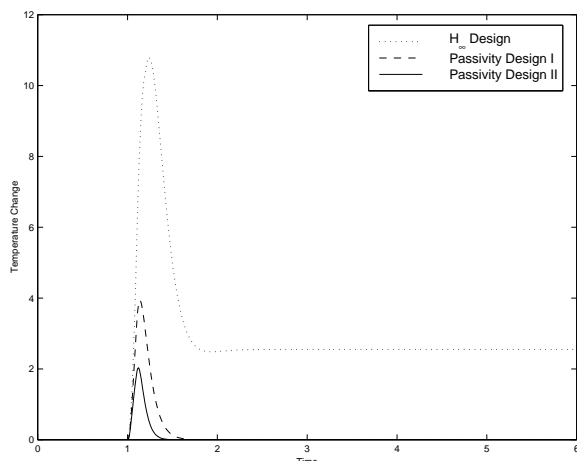

Figure 8: Closed-loop simulation results for the CSTR.

to 0.5 kmol/m^3 and c_2 increases from 2 kmol/m^3 to 3 kmol/m^3 . Simulations shown in Figure 7 verify that the proposed design is less conservative. The only purpose of this example is to show that conservatism can be further reduced in the over passive case by simply applying a loop transform, therefore, simulation results are less dramatic as uncertainty $\Delta_2 = 0$ in this case.

Our second example demonstrates the advantage of the framework proposed in this paper. This example uses the CSTR mentioned above. It is assumed that there are linearization errors and perturbations on the feed flowrate F , feed concentration C_0 and feed temperature T_0 , as well as first-order measurement dynamics. The object is to design a controller such that the system is stable under feed perturbations, measurement dynamics and linearization errors. The details of the example have to be omitted due to space limitations.

Similar to Bao et al. (1999), a standard H_∞ design was carried out for comparison purpose. The H_∞ design assumes that there are no measurement dynamics.

Two passivity based design were studied, namely, Passivity Design I and Passivity Design II. Passivity Design I is similar to the one in Bao et al. (1999) by assuming that there are no measurement dynamics. The process was only perturbed by the feed perturbations which lead to a near passive Δ_1 in Figure 3. Similar to Bao et al. (1999), linearization error was partially taken into account by the Δ_1 block. However, unlike the procedure in Bao et al. (1999), frequency weighting was not used for simplicity. Passivity Design II uses the methodology proposed in this paper. There was no specific assumption on perturbation, linearization errors or measurement dynamics as those imposed in the H_∞ design and the Passive Design I. Similar to Passive Design I, frequency weighting was not used. However, it should be stressed that frequency weighting can be adopted for

all three designs to further improve performance.

Three controllers were synthesized using the three design methods. They were then applied to the nonlinear component and energy balance model to simulate the behaviour of the closed-loop system. It was assumed that simultaneously feed perturbations occur at $t = 1 \text{ min}$ after the closed loop reached steady state. Figure 8 shows the control errors of the reactor temperature corresponding to the three controllers. It can be observed that the H_∞ controller performs worse with a steady state offset and longer transition period, and the Passivity Design II controller is the best.

Conclusion

A new methodology is proposed in this paper to deal with robust stability analysis and controller synthesis of nonlinear chemical processes. The proposed approach is based on passivity theory which may be less conservative than the commonly used H_∞ approach in robust control. The framework used in this paper enables the consideration of near passive and over passive uncertainties in a unified way, and also allows a larger class of uncertainties existing in the chemical processes.

References

- Bao, J., P. L. Lee, F. Wang, and W. Zhou, "New robust stability criterion and robust controller synthesis," *Int. J. Robust Nonlinear Contr.* (1999).
- Boyd, S., L. El Ghaoui, E. Feron, and V. Balakrishnan, *Linear Matrix Inequalities in System and Control Theory*. Philadelphia: SIAM (1994).
- Desoer, C. A. and M. Vidyasagar, *Feedback Systems: Input-Output Properties*. Academic Press, NY (1975).
- Doyle III, F. J., A. K. Packard, and M. Morari, Robust controller design for a nonlinear CSTR, In *Proc. 1989 American Contr. Conf.*, pages 1087–1092 (1989).
- Lee, P. L., H. Li, and I. T. Cameron, "Decentralized control design for nonlinear multi-unit plants: a gap metric approach," *Chem. Eng. Sci.*, **55**, 3743–3758 (2000).
- Mylroi, M. G. and G. Calvert, *Measurement and Instrumentation for Control*. Peter Peregrinus Ltd., London (1986).
- Sakamoto, N. and M. Suzuki, " γ -Passive System and Its Phase Property and Synthesis," *IEEE Trans. Auto. Cont.*, **41**, 859–865 (1996).
- Xie, L. and Y. C. Soh, "Positive real control problem for uncertain linear time-invariant systems," *Sys. Cont. Let.*, **24**, 265–271 (1995).
- Xie, L., M. Fu, and H. Li, "Passivity analysis and passification for uncertain signal processing systems," *IEEE Trans. Signal Proces.*, **46**(9), 2394–2403 (1998).
- Zhou, K., J. C. Doyle, and K. Glover, *Robust and Optimal Control*. Prentice Hall (1996).