

Generalized Nash Equilibrium and Market Coupling in the European Power System

Yves Smeers, Giorgia Oggioni, Elisabetta Allevi and Siegfried
Schaible

June 2010

CWPE 1034 & EPRG 1016

Generalized Nash Equilibrium and Market Coupling in the European Power System

EPRG Working Paper 1016

Cambridge Working Paper in Economics 1034

Yves Smeers, Giorgia Oggioni, Elisabetta Allevi
and Siegfried Schaible

Abstract

"Market Coupling" is currently seen as the most advanced market design in the restructuring of the European electricity market. Market coupling, by construction, introduces what is generally referred to as an incomplete market: it leaves several constraints out of the market and hence avoids pricing them. This may or may not have important consequences in practice depending on the case on hand. Quasi-Variational Inequality problems and the associated Generalized Nash Equilibrium can be used for representing incomplete markets. Recent papers propose methods for finding a set of solutions of Quasi-Variational Inequality problems. We apply one of these methods to a subproblem of market coupling namely the coordination of counter-trading. This problem is an illustration of a more general question encountered for instance in hierarchical planning in production management. We first discuss the economic interpretation of the Quasi-Variational Inequality problem. We then apply the algorithmic approach to a set of stylized case studies in order to illustrate the impact of different organizations of counter-trading. The paper emphasises the structuring of the problem. A companion paper considers the full problem of market coupling and counter-trading and presents a more extensive numerical analysis.

Keywords Generalized Nash Equilibrium, Quasi-Variational Inequalities, Market Coupling, Counter-Trading, European Electricity Market

JEL Classification D52, D58, Q40

Contact yvessmeers@me.com
Publication June 2010



Generalized Nash Equilibrium and Market Coupling in the European Power System

Yves Smeers*

Université catholique de Louvain, School of Engineering (INMA) and CORE, Belgium

Giorgia Oggioni

University of Brescia, Department of Quantitative Methods, Italy

Elisabetta Allevi

University of Brescia, Department of Quantitative Methods, Italy

Siegfried Schaible

Chung Yuan Christian University, Department of Applied Mathematics, Taiwan

June 23, 2010

1 Introduction

The restructuring of the European electricity market is a long process. The integration of various national markets through the so called “Market Coupling” approach is currently the most advanced market design in Europe. In contrast with the standard US approach to restructuring that aims at transforming the numerous constraints appearing in the electricity system in specially designed markets, market coupling essentially relies on an energy market and leaves it to the Transmission System Operators (TSOs¹) to take care of most of these constraints by a mix of market and quantitative constructs. The result is what economists call an incomplete market where several constraints are not priced by the market. We take up a particular question of market coupling namely the removal of congestion through counter-trading. This problem has been encountered in many jurisdictions outside of Central Western Europe and hence is of general interest. We then look at the problem of the organization of counter-trading by different system operators through

*Corresponding author: Université catholique de Louvain, School of Engineering (INMA) and CORE, Voie du Roman Pays, B-1348 Louvain-la-Neuve, Belgium. t: +32 (0)10 474323, e: yvessmeers@me.com. The authors are grateful to one anonymous referee. The usual disclaimer applies.

¹Transmission System Operator (TSO) is a company that is responsible for operating, maintaining and developing the transmission system for a control area and its interconnections. See ENTSO website.

the glasses of Generalized Nash Equilibrium (*GNE*), which provides a natural context for modeling incomplete markets. Generalized Nash Equilibria are related to Quasi-Variational Inequality (*QVI*) models for which computational advances have recently been proposed. *QVI* problems are extensions of Variational Inequality (*VI*) problems. They differ by both their mathematical properties and economic interpretations. This paper implicitly uses the *VI* and *QVI* concepts by respectively referring to the Nash Equilibrium (*NE*) and Generalized Nash Equilibrium (*GNE*) problems.

A Nash Equilibrium describes an equilibrium between agents interacting through their payoffs: the action of one agent influences the payoff of another agent. A Generalized Nash Equilibrium involves agents that interact both at the level of their payoffs, but also through their strategy sets: the action of an agent can influence the payoff of another agent, but it can also change the set of actions that this agent can undertake. The idea of using Generalized Nash Equilibrium in electricity transmission controlled by several operators is quite natural: because of Kirchhoff's laws, the actions of one operator influences the set of possible actions of another operator. A transmission system operated by different operators is thus naturally described by a Generalized Nash Equilibrium.

The concept of *GNE* was first introduced by Arrow and Debreu in [1] and Debreu in [3] where they refer to these problems as an abstract economy. Apart from these pioneering contributions, only in the nineties were *GNEs* recognized for their numerous applications in economics, mathematics and engineering. In the context of electricity applications, Wei and Smeers [13], solve a *GNE* problem for an oligopolistic electricity market where generators behave à la Cournot and transmission prices are regulated. Pang and Fukushima [10] show how a non-cooperative multi-leader-follower game applied to the electricity market can be expressed as a *GNE* problem. This latter model is an example of an Equilibrium Problem subject to Equilibrium Constraints (*EPEC*) (see Ralph and Smeers [11] for an illustration of a related example of such a problem). *EPEC* problems are more complex than the *QVI* problems discussed here where we concentrate on *GNEs* that arise when players share a common good (like power, transport and telecommunication networks), but are not valued by the market at a single price. In the literature, this is referred to as a problem with shared constraints. The lack of a unique price for a shared constraint makes the market incomplete. This is reflected in a multiplicity of dual variables of the common constraints. Our interest is about *GNE* problems that have an interpretation of incomplete markets for resources described by shared constraints. Mathematically we are interested in exploring solutions of the *QVI* where the dual variables of the shared constraints differ.

The general situation is that a quasi-variational problem has a plurality of solutions that include those of the underlying *VI* problem. In his seminal paper (see Theorem 6 [6]), Harker proves that the *VI* solutions are the only points in the solution set of the *QVI* when the dual variables associated to shared constraints are identical for all players. This has an important implication: solving the *VI* gives a solution to the *QVI*. There is also a shortcoming, solving the *VI* does not say anything about the other solutions of the *QVI*. Differently from *VI*, only few methods are available for

solving *GNE* problems (see Fukushima [5] and Facchinei and Kanzow [4] for a complete overview).

Recently, Fukushima ([5]) has introduced the new class of restricted *GNE* that can be considered as an extension of the normalized Nash Equilibrium. A normalized equilibrium, initially introduced by Rosen [12], is a special *GNE* where the multipliers of the shared constraints are equal among all players up to a constant factor. In his paper [5], Fukushima defines the restricted *GNE* for the class of *GNE* problems with shared constraints and presents a controlled penalty method to find a restricted *GNE*. However, in some cases, it could be interesting to have the full set of solutions of the *GNE* problem. A recent paper by Fukushima in collaboration with Nabetani and Tseng (see [7]) suggests two parametrized *VI* approaches respectively called price-directed and resource directed, to capture all *GNEs*.

The contribution of this paper can be summarized as follows. We discuss the economic insight provided by the price-directed parametrization algorithm (see [7]) on market coupling and on the organization of counter-trading applied to the restructured European electricity system. Market coupling is currently implemented in France, Belgium and the Netherlands and it will be soon extended to Germany. This market organization is based on the separation of the energy and transmission markets. The energy market is subdivided into zones, each controlled by a Power Exchange (PX²), that are interconnected by lines, with limited transfer capacity, which provide a simplified representation of the grid. Taking stock of this information on the interconnections, PXs clear energy markets, but the resulting flows may be not feasible with real network. This forces TSOs to re-shuffle power flows in order to eliminate overflows and restore network feasibility. The set of these operations is known as counter-trading or re-dispatching. The deriving costs change according to the degree of coordination of the different TSOs and they are usually charged to power producers or consumers. This problem can be considered as an illustration of a more general problem encountered for instance in hierarchical planning in production management. We first discuss the economic interpretation of the variational and quasi-variational inequality problem and some of its implications for algorithmic purposes. We then apply the methods to a set of counter-trading case studies and report the results as well as the advantages and shortcoming encountered. The paper emphasises the numerical aspects of different counter-trading models where TSOs operate in a more or less integrated way. These models are applied to a six node network that we assume to be subdivided into two zones (North and South). These zones have an inter-connector with limited transfer capacity. Each zone is controlled by a PX and a TSO. We assume that PXs are coordinated and then operate as if they were a sole entity; while TSOs can be coordinated or uncoordinated. We first model the case where TSOs operate in a integrated way to then move to situations where TSOs are not coordinated and have different controls on the counter-trading resources. A companion paper goes in more detail into the economics of the problem (see Oggioni and Smeers [9]). The results of a more realistic study are illustrated by Oggioni and Smeers in [8], where the analysis is applied to a prototype of the North-Western

²A Power Exchange (PX) is an operator with the mission of organizing and economically managing the electricity market, while guaranteeing competition between producers.

European electricity market.

The remainder of the paper is organized as follows. In Section 2, we recall the mathematical background; Section 3 introduces the economic interpretation, the data and the network used for the empirical analysis. Section 4 is devoted to the explanation of the models and some theoretical results, while the results of the simulations are reported in Section 5. Finally, Section 6 concludes with the last observations.

2 Mathematical Background

This section reviews the mathematical instruments used in the paper. The QVI problem defined by the pair $QVI(F, K)$ is to find a vector $x^* \in K(x^*)$ such that:

$$F(x^*)^T(x - x^*) \geq 0 \quad \forall x \in K(x^*) \quad (1)$$

where $K(x)$ is a point to set mapping from \mathfrak{R}^n into a subset of \mathfrak{R}^n and F is a point-to-point mapping from \mathfrak{R}^n into itself.

There exists a strict correspondence between QVI and a related GNE problem defined as follows. Suppose that each player i solves the following utility maximization problem, where its strategy x^i is affected by the strategy $x^{N \setminus i}$ of the other $N \setminus i$ players:

$$\begin{aligned} \mathbf{Max}_{x^i} \quad & u^i(x^i, x^{N \setminus i}) \\ \text{s.t.} \quad & x^i \in K^i(x^{N \setminus i}) \end{aligned} \quad (2)$$

A GNE of the game is thus defined as a point $x^* = (x^{*1}, x^{*2}, \dots, x^{*n}) \in K(x^*)$ such that:

$$u^i(x^*) \geq u^i(x^i, x^{*N \setminus i}) \quad \forall x^i \in K^i(x^{*N \setminus i}) \quad i \in N$$

$K^i : x^{N \setminus i} \rightarrow X^i$ is a point to set map which represents the ability of player $N \setminus i$ to influence the feasible strategy set of player i .

The QVI formulation of this GNE problem is then defined as follows:

$$-\nabla_{x^i} u^i(x^{*i}, x^{*N \setminus i})^T(x^i - x^{*i}) \geq 0 \quad \forall x^i \in K^i(x^{*N \setminus i}) \quad (3)$$

and the more compact form is:

$$F(x^*)^T(x - x^*) \geq 0 \quad \forall x \in K(x^*) \quad (4)$$

where $F^T(x^*) \equiv (-\nabla_{x^1}^T u^1(x^*), \dots, -\nabla_{x^N}^T u^N(x^*))$ and $K(x^*) \equiv \prod_i^N K^i(x^{*N \setminus i})$.

Different particularizations of the solution set of the QVI have been offered in the literature. They are presented in the following through an example that we complement with some economic interpretations that will be important in the rest of the paper.

2.1 Particular cases

Assume an economic system with three players ($N = 1, \dots, 3$) and two common constraints ($m = 1, 2$) that each expresses a limitation in some resources. Each player i solves an optimization problem taking into account the limitation of resources expressed in the two constraints. The players' problems are stated below with the dual variables of their constraints indicated at the right:

The first player solves:

$$\mathbf{Min}_{x^1} \theta^1 = (x^1)^2 + x^1 x^2 - x^1 x^3 \quad (5)$$

$$x^1 - 2x^2 + x^3 \geq 2.4 \quad (\lambda^1) \quad (6)$$

$$x^1 + x^2 + x^3 \geq 3 \quad (\beta^1) \quad (7)$$

$$x^1 \geq 0 \quad (\omega^1) \quad (8)$$

The second player's problem is:

$$\mathbf{Min}_{x^2} \theta^2 = (x^2)^2 + x^1 x^2 + x^2 x^3 \quad (9)$$

$$x^1 - 2x^2 + x^3 \geq 2.4 \quad (\lambda^2) \quad (10)$$

$$x^1 + x^2 + x^3 \geq 3 \quad (\beta^2) \quad (11)$$

$$x^2 \geq 0 \quad (\omega^2) \quad (12)$$

And finally the third player solves:

$$\mathbf{Min}_{x^3} \theta^3 = (x^3)^2 + x^1 x^3 + x^2 x^3 \quad (13)$$

$$x^1 - 2x^2 + x^3 \geq 2.4 \quad (\lambda^3) \quad (14)$$

$$x^1 + x^2 + x^3 \geq 3 \quad (\beta^3) \quad (15)$$

$$x^3 \geq 0 \quad (\omega^3) \quad (16)$$

Following Theorem 6 of Harker [6], we single out the solution of a *QVI* for which the dual variables of all players' common constraints are identical and we write the KKT conditions of these different problems as:

$$0 \leq 2x^1 + x^2 - x^3 - \lambda - \beta \perp x^1 \geq 0 \quad (17)$$

$$0 \leq x^1 - 2x^2 + x^3 - 2.4 \perp \lambda \geq 0 \quad (18)$$

$$0 \leq x^1 + x^2 + x^3 - 3 \perp \beta \geq 0 \quad (19)$$

for the first player and

$$0 \leq 2x^2 + x^1 + x^3 + 2\lambda - \beta \perp x^2 \geq 0 \quad (20)$$

$$0 \leq x^1 - 2x^2 + x^3 - 2.4 \perp \lambda \geq 0 \quad (21)$$

$$0 \leq x^1 + x^2 + x^3 - 3\perp\beta \geq 0 \quad (22)$$

for the second player. Finally for the third player:

$$0 \leq 2x^3 + x^1 + x^2 - \lambda - \beta\perp x^3 \geq 0 \quad (23)$$

$$0 \leq x^1 - 2x^2 + x^3 - 2.4\perp\lambda \geq 0 \quad (24)$$

$$0 \leq x^1 + x^2 + x^3 - 3\perp\beta \geq 0 \quad (25)$$

The solution of this three players' problem is $\mathbf{x} = [2.1, 0.2, 0.7]^T$. This makes the two constraints binding and λ and β amount to 0.167 and 3.533 respectively. We interpret this model as one where a market allocates the common resources represented in the two constraints through a single price system (one price for each constraint). We refer to this scenario as "case 1".

Rosen's ([12]) considers another solution of the *QVI* problem where the dual variables of the shared constraints are equal among all players up to a constant factor r^i that depends on players, but not on the constraints. This is mathematically expressed as:

$$\lambda^i = \lambda/r^i \quad i = 1, 2, 3 \quad (26)$$

$$\beta^i = \beta/r^i \quad i = 1, 2, 3 \quad (27)$$

Rosen refers to this solution as normalized equilibrium. The complementarity formulation of the problem is as follows:

$$0 \leq 2x^1 + x^2 - x^3 - \lambda^1 - \beta^1\perp x^1 \geq 0 \quad (28)$$

$$0 \leq x^1 - 2x^2 + x^3 - 2.4\perp\lambda^1 \geq 0 \quad (29)$$

$$0 \leq x^1 + x^2 + x^3 - 3\perp\beta^1 \geq 0 \quad (30)$$

for the first player, while that of the second player is:

$$0 \leq 2x^2 + x^1 + x^3 + 2\lambda^2 - \beta^2\perp x^2 \geq 0 \quad (31)$$

$$0 \leq x^1 - 2x^2 + x^3 - 2.4\perp\lambda^2 \geq 0 \quad (32)$$

$$0 \leq x^1 + x^2 + x^3 - 3\perp\beta^2 \geq 0 \quad (33)$$

Finally that of the third player is stated as:

$$0 \leq 2x^3 + x^1 + x^2 - \lambda^3 - \beta^3\perp x^3 \geq 0 \quad (34)$$

$$0 \leq x^1 - 2x^2 + x^3 - 2.4\perp\lambda^3 \geq 0 \quad (35)$$

$$0 \leq x^1 + x^2 + x^3 - 3\perp\beta^3 \geq 0 \quad (36)$$

Rosen's normalized equilibrium is obtained when the dual variables of the shared constraints are equal among all players up to a constant factor r^i .

We denote this scenario as “case 2” and we interpret it as one where there is an imperfect market for allocating the common resources of the two constraints. Prices tend to equalize, but there remains a gap. This can easily be interpreted as the bid-ask spread found in insufficiently liquid markets. Assuming that $r_1 = 1.05$, $r_2 = 1$ and $r_3 = 0.95$, the solution of the normalized Nash equilibrium becomes $\mathbf{x} = [2.01, 0.2, 0.790]^T$ and the corresponding values of λ^i and β^i are as stated in Table 1.

λ^i	Values	β^i	Values
λ^1	0.127	β^1	3.302
λ^2	0.134	β^2	3.467
λ^3	0.141	β^3	3.650

Table 1: λ^i and β^i values in the normalized equilibrium (case 2)

Fukushima ([5]) generalizes this notion and considers the more general case of a restricted QVI or GNE problem by imposing that the relative values of different resources differ among players. A tuple $x = (x^1, \dots, x^N)$ is said to be a restricted GNE , if there exists Lagrange multipliers $\lambda = (\lambda_i^v) \dots$ that satisfy $\overline{KKT}_v, v = 1, \dots, N$ together with the additional conditions³:

$$\lambda = (\lambda_i^v) \in \Lambda$$

where Λ is a nonempty cone in \mathfrak{R}_+^{mN} . The class of restricted GNE extends the Rosen’s normalized equilibrium (see above for the definition of normalized equilibrium). In other words, one has a restricted GNE when *the ratio of shadow prices associated with the common resources is neither too large nor too small for every pair of player*⁴. Considering our three players example, this can be expressed by conditions:

$$\frac{\bar{\delta}\lambda^1}{r^1} \leq \frac{\lambda^2}{r^2} \leq \frac{\underline{\delta}\lambda^1}{r^1} \quad \text{and} \quad \frac{\bar{\delta}\lambda^2}{r^2} \leq \frac{\lambda^3}{r^3} \leq \frac{\underline{\delta}\lambda^2}{r^2} \quad (37)$$

$$\frac{\bar{\epsilon}\beta^1}{r^1} \leq \frac{\beta^2}{r^2} \leq \frac{\underline{\epsilon}\beta^1}{r^1} \quad \text{and} \quad \frac{\bar{\epsilon}\beta^2}{r^2} \leq \frac{\beta^3}{r^3} \leq \frac{\underline{\epsilon}\beta^2}{r^2} \quad (38)$$

One may be interested in other solutions of the QVI . Suppose for instance that we want to impose $\lambda^1 = \lambda + 0.05$, $\lambda^2 = \lambda$ and $\lambda^3 = \lambda - 0.05$, $\beta^1 = \beta + 1$, $\beta^2 = \beta$ and $\beta^3 = \beta - 1$. The solution of this particular GNE is $\mathbf{x} = [2.625, 0.2, 0.175]^T$ and the corresponding values of α^i and β^i are reported in Table 2. This is the kind of GNE that we want to tackle in this paper and, in particular, the difference between dual variables can be interpreted as a lack of arbitrage in incomplete markets. This is our “case 3”.

³Directly taken from Fukushima [5].

⁴Directly taken from Fukushima [5].

λ^i	Values	β^i	Values
λ^1	0.392	β^1	4.883
λ^2	0.342	β^2	3.883
λ^3	0.292	β^3	2.883

Table 2: λ^i and β^i values at equilibrium (case 3)

A particular case of the above is to impose $\lambda^1 = \lambda + 0.05$, $\lambda^2 = \lambda$ and $\lambda^3 = \lambda - 0.05$ while $\beta^i = \beta$. The solution to this *GNE* thus becomes $\mathbf{x} = [2.125, 0.2, 0.675]^T$ with the corresponding α^i and β^i in Table 3. The interpretation of this situation is an economic system where some resources are effectively priced by the market (those that have identical dual variables), but others are not or only imperfectly priced. We denote it as “case 4”.

λ^i	Values	β^i	Values
λ^1	0.225	β^1	3.350
λ^2	0.175	β^2	3.350
λ^3	0.125	β^3	3.350

Table 3: λ^i and β^i values at equilibrium (case 4)

We motivate our interest in that problem in Section 3 where we discuss a real world example of that situation. We now explain that the parametrized *VI* approach proposed by Nabetani, Tseng, Fukushima (NTF hereafter), that we briefly present next, provides a particularly attractive way to handle that problem, both numerically and in terms of its economic interpretation.

2.2 The NTF price directive algorithm

Consider the following *GNE* defined as follows. For each $i = 1, \dots, N$, find x^{*i} such that for given $x^{*N \setminus i}$ optimally solves the following convex optimization problem:

$$\begin{aligned} \mathbf{Min}_{x^i} \quad & \theta^i(x^i, x^{*N \setminus i}) \\ \text{s.t.} \quad & g(x^i, x^{*N \setminus i}) \leq 0 \quad x^i \in K^i(x^{*N \setminus i}) \end{aligned} \quad (39)$$

where $g(x^i, x^{*N \setminus i})$ are the players’ common constraints. The parametrized *VI* approach proposed by Nabetani, Tseng, Fukushima solves that *GNE* problem through a family of *VI*s defined as follows. Consider a problem $VI(F^\gamma, K)$ where the mapping $F^\gamma : \mathfrak{R}^n \rightarrow \mathfrak{R}^n$ is defined as follows:

$$F^\gamma(x) = (\nabla_{x^i} \theta^i(x) + \nabla_{x^i} g(x) \gamma^i)_{i=1}^N \quad (40)$$

and γ^i is a parameter assigned to each player i . These authors show that the solution set of a *GNE* problem is a subset of the solution set of these parametrized $VI(F^\gamma, K)$. In Theorem 3.3 of

[7], they also give conditions for identifying when a solution of $VI(F^\gamma, K)$ is effectively a *GNE*. Consider the KKT conditions for $VI(F^\gamma, K)$:

$$0 \in [(\nabla_{x^i} \theta^i(x) + \nabla_{x^i} g(x) \gamma^i) + \nabla_{x^i} g(x) \pi], \quad i = 1, \dots, N$$

$$0 \leq \pi \perp g(x) \geq 0, \quad x_i \in X_i, \quad i = 1, \dots, N$$

Theorem 3.3 says that for any $\gamma \in \mathbb{R}_+^{mN}$ and any $(x^*, \pi^*) \in \mathbb{R}^n \times \mathbb{R}^m$ satisfying the KKT conditions indicated above, a sufficient condition for x^* to be a *GNE* is that:

$$\langle g(x^*), \gamma_i \rangle = 0, \quad i = 1, \dots, N. \quad (41)$$

If in addition a constraint qualification condition holds at x^* , then (41) is also a necessary condition for x^* to be a *GNE*. This algorithm can be easily adapted to the problem treated in this paper.

The following section provides the economic intuition that motivates this problem. We first present the problem in general terms and then adapt it to the particular situation that is treated in Section 3.3.

3 Economic interpretation

3.1 A general production context

Nash equilibria are commonly used in economics to describe markets affected by market power. In contrast, we concentrate in this paper on markets where all agents are price takers and hence there is no market power. This was the context adopted by Debreu and Arrow and Debreu in [3] and [1] for introducing social equilibrium. Specifically we consider the following social equilibrium problem that arises in production management. Consider the problem of decentralizing the activities of an organization into different Business Units (*BU*) that is each evaluated on its own performance. The interactions between the business units are of two types. First, actions of one *BU* can influence the payoff (performance index) of another *BU*. Second, all *BUs* share common constraints (resource availability or operations constraint) with the implication that the actions of one *BU* can change the remaining resources available to the other *BUs*. Both types of interactions are known by economists as externalities. Negative externalities create inefficiencies; positive externalities create benefits. While the organization can in principle achieve its best result by an overall optimization, it is believed that the centralization of operations required by this optimization decreases individual incentives to be efficient (moral hazard in economic parlance).

The decentralization process consists in assembling activities in *BUs* and organizing internal markets for shared resources. We explained that integrating all operations would maximize efficiency where it is not for a degradation of individual incentives. In a similar way, efficiency justifies creating an internal market for all common resources or restrictions in the decentralized organisation (see the treatment of common constraints in Dantzig-Wolfe decomposition), except if,

following Williamson's theory [14], externalizing transactions through these markets would increase costs with respect to keeping them inside an integrated firm. There is thus a trade-off in decentralization between increasing individual incentives towards efficiency and incurring costs because of loss of coordination. We justify the introduction of our problem as an instrument to measure the economic cost resulting from the loss of coordination in decentralized operations.

The economic problem can be analyzed in two stages. A first question is to group activities into *BUs*, the other is to decide which resource or restriction to allocate through a market and which not. The first problem can be handled by testing different groupings of activities. Suppose, in order to treat the second question, that the decomposition of the overall organisation in *BUs* is defined. The question then arises as to the creation of an internal market for common resources or restrictions. The resources or constraints allocated through an internal market have a common price charged by all *BUs*. The other resources can be valued differently by the different *BUs* without any market reconciling these different valuations into a single price or opportunity cost. Inefficiency arises from both improper grouping of activities and price differences that signal residual arbitrage possibilities. Assessing this inefficiency can then be done either by measuring the additional cost incurred by the decentralized organization or by valuing the remaining arbitrage possibilities. The *NTF* price directed algorithm provides a particularly attractive way to tackle that problem. We apply these general ideas to the particular problem of counter-trading in restructured electricity systems, that we describe after introducing a *GNE* formulation of the above discussion.

3.2 Formulation in terms of *GNE*

3.2.1 Problem statement

We formulate the above problem in the following abstract way. There are two *BUs*, each noted $i = N, S$ (in order to use the same notation as in the rest of the paper). Each *BU* maximizes a utility function $U^i(x)$ taking into account both common and individual constraints. Some of the constraints are considered sufficiently important for organizing a common market. Others are seen as less important and hence left to informal arrangements.

Player N solves the following problem:

$$\mathbf{Max}_{x^N} U^N(x^N, x^S) \tag{42}$$

s.t.

$$X^N(x^N) = 0 \quad (\nu^N) \tag{43}$$

$$Y(x^N, x^S) = Y^N(x^N) + Y^S(x^S) \geq 0 \quad (\mu^N) \tag{44}$$

$$Z(x^N, x^S) = Z^N(x^N) + Z^S(x^S) \geq 0 \quad (\lambda^N) \tag{45}$$

where the function U^N and X^N are respectively the utility and the own constraint of player N ; Y and Z are the common and separable constraints, Y denoting those for which a common market

has been put in place. The second player, labeled S (South), solves the following similar problem:

$$\mathbf{Max}_{x^S} U^S(x^N, x^S) \quad (46)$$

s.t.

$$X^S(x^S) = 0 \quad (\nu^S) \quad (47)$$

$$Y(x^N, x^S) = Y^N(x^N) + Y^S(x^S) \geq 0 \quad (\mu^S) \quad (48)$$

$$Z(x^N, x^S) = Z^N(x^N) + Z^S(x^S) \geq 0 \quad (\lambda^S) \quad (49)$$

The combination of these two optimization problems constitutes a Generalized Nash Equilibrium problem. Referring to the above interpretation we impose that the dual variables μ^N and μ^S are equal because they can be interpreted as a transfer price in the common market of constraints Y . In contrast, λ^N and λ^S can be different because no internal market has been created for these common constraints. ν^N and ν^S refer to BUs ' own constraints and hence can be expected to be different. This is a particular Generalized Nash Equilibrium in the sense that some of the constraints are priced by the market and hence their dual variables are equal for both players. But the market is incomplete in the sense that it does not cover all common constraints and the dual variables of the uncovered constraints can be different. The theory of GNE tells us that there may be several solutions to this problem, implying that the outcome of the organization is intrinsically ambiguous. It is thus relevant to inquire whether these different outcomes can be far apart some of them being quite inefficient compared to the outcome where all constraints would be priced by a complete market. Conversely one may wonder whether there are cases where there is a single outcome (the QVI and the associated VI have identical solution sets).

We explore this question by applying the parametrized variational inequality approach described by Nabetani, Tseng and Fukushima in [7] and construct the following parametrized model.

$$\mathbf{Max}_{x^N, x^S} U^N(x^N, x^S) + U^S(x^N, x^S) + (Z^N(x^N))\gamma^N + (Z^S(x^S))\gamma^S \quad (50)$$

s.t.

$$X^N(x^N) = 0 \quad (\nu^N) \quad (51)$$

$$X^S(x^S) = 0 \quad (\nu^S) \quad (52)$$

$$Y(x^N, x^S) = Y^N(x^N) + Y^S(x^S) \geq 0 \quad (\mu) \quad (53)$$

$$Z(x^N, x^S) = Z^N(x^N) + Z^S(x^S) \geq 0 \quad (\lambda) \quad (54)$$

Changing the γ parameters leads to different Generalized Nash Equilibria provided that positive γ are associated to a positive λ . There is only a single GNE if it is impossible to generate different GNE by modifying the γ . Assuming adequate constraint qualification and the optimization problem is feasible, this can only happen if the optimization problem is unbounded. This occurs if it

does not have any primal dual solution, a property that can be checked on the complementarity theorem obtained from the KKT conditions of the optimization problem. These are stated as:

$$0 \geq \frac{\partial_{x^N} U^N(x^N, x^S)}{\partial x^N} + \gamma^N \frac{\partial_{x^N} Z^N(x^N)}{\partial x^N} + \nu^N \frac{\partial_{x^N} X^N(x^N)}{\partial x^N} + \mu \frac{\partial_{x^N} Y^N(x^N)}{\partial x^N} + \lambda \frac{\partial_{x^N} Z^N(x^N)}{\partial x^N} \perp x^N \geq 0$$

$$0 \geq \frac{\partial_{x^S} U^S(x^N, x^S)}{\partial x^S} + \gamma^S \frac{\partial_{x^S} Z^S(x^S)}{\partial x^S} + \nu^S \frac{\partial_{x^S} X^S(x^S)}{\partial x^S} + \mu \frac{\partial_{x^S} Y^S(x^S)}{\partial x^S} + \lambda \frac{\partial_{x^S} Z^S(x^S)}{\partial x^S} \perp x^S \geq 0$$

$$0 \leq Y(x^N, x^S) \perp \mu \geq 0 \tag{55}$$

$$0 \leq Z(x^N, x^S) \perp \lambda \geq 0 \tag{56}$$

$$X^N(x^N) = 0 \quad (\nu^N) \tag{57}$$

$$X^S(x^S) = 0 \quad (\nu^S) \tag{58}$$

3.2.2 Assessing inefficiencies

The above model can be used to test the inefficiency of a particular organization. These arise from two sources. One is in the delineation of the individual constraints of the *BUs* (the X constraints) when they result from an ex ante allocation of some common resources. The other source of inefficiency is the absence of a common market for the resources that remain common. This is expressed by the difference of valuation of these resources by the *BU* (the dual variables). In all cases this implies a change of the utility function value of the *BUs*. It is this approach that we illustrate in the following application taken from the restructuring of the European electricity market.

3.3 Counter-trading in restructured electricity markets

The operations of the electricity system under the regulatory regime is the paradigm of the fully centralized and optimized organisation of operations: all machines operating in the short run are under the control of a single optimization problem. The underlying philosophy of the restructuring of the sector is that decentralising operations improve the incentive of individual agents (generators, traders, consumers) to be efficient, possibly at the cost of some loss of coordination of operations. The question is to find a good trade-off by gaining on incentives without losing too much on coordination. We here consider a particular problem that arises in the European context of electricity restructuring namely the organisation of counter-trading after the clearing of the energy market by Power Exchanges. A full description of the overall problem, namely the so called market coupling, would lead us too far away from the numerical objective of this paper and we therefore report a brief summary in Appendix A (see the companion paper [9] for more details). We here restrict ourselves to the subproblem of counter-trading that we describe on the basis of a six node example initially presented by Chao and Peck in [2].

3.3.1 The test problem

Consider the six node network depicted in Figure 1 introduced by Chao and Peck (see [2]).

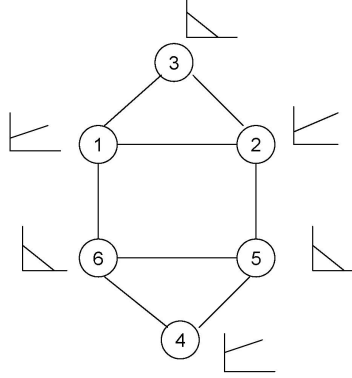

Figure 1: Six node market (Chao and Peck (1998))

The network accounts for eight lines of which only two have limited capacity. These are line (1-6) and (2-5) with a respective capacity of 200 and 250 MW. Kirchhoff's laws are represented by a Power Transfer Distribution Factor (PTDF) matrix that indicates the portions of energy that, after being injected into a node or before being withdrawn from a hub node (node 6 in the example) flows through the lines. In this example, the PTDF matrix concerns only lines (1-6) and (2-5) and its elements are reported in Table 4. Electricity is produced in nodes $i = 1, 2, 4$ and consumed in

Power (1 MW) Injected at Node	Power flow on link 1 \rightarrow 6 (MW)	Power flow on link 2 \rightarrow 5 (MW)
1	0.625	0.375
2	0.5	0.5
3	0.5625	0.4375
4	0.0625	-0.0625
5	0.125	-0.125
6 (hub)	0	0

Table 4: PTDF of the 6 node market (Chao and Peck (1998))

nodes $j = 3, 5, 6$. Marginal production cost ($c(q_i)$) and inverse demand ($w(q_j)$) functions are given in Table 5.

3.3.2 Counter-trading

Assume a zonal energy market decomposed in two Northern and Southern zones as depicted in Figure 2 (see [9] for more details). Zones are currently associated to countries in Europe and there

Node	Function Type	Function
1	$c(q_1)$	$10+0.05q$
2	$c(q_2)$	$15+0.05q$
3	$w(q_3)$	$37.5-0.05q$
4	$c(q_4)$	$42.5+0.025q$
5	$w(q_5)$	$75-0.1q$
6	$w(q_6)$	$80-0.1q$

Table 5: Demand and cost functions of the 6 node market (Chao and Peck (1998))

is one PX and one TSO per country. We refer to the Northern and Southern TSOs as TSO^N and TSO^S respectively.

Consider a set of energy trades resulting from the clearing of the energy market by the PXs in market coupling (see Appendix A). These trades have been obtained on the basis of a simplified representation of the grid (like in Figure 2) and hence can sometimes lead to excessive flows on some lines of the real network. Counter-trading is the operations whereby TSOs buy incremental or decremental injections at different nodes of the grid so as to modify the flows on the lines and make them compatible with the real capabilities of the grid, namely network in Figure 1, in real time. Counter-trading does not change the energy transactions cleared in the energy market as these are settled at the prices arrived at by the PXs. Counter-trading is an other market that is settled separately. It can be organized in different ways of which we discuss a few possibilities.

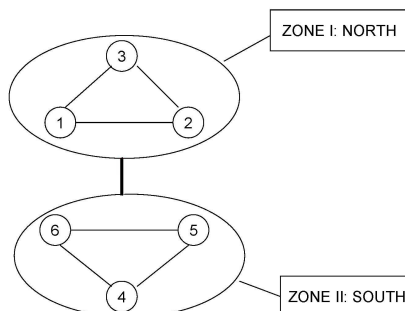

Figure 2: Two zones market

3.3.3 Counter-trading is fully optimized

We first consider an arrangement where both TSOs operate as a single entity. This corresponds to an overall optimization of all counter-trading operations by an entity that has access to all counter-trading resources (incremental and decremental injections and withdrawals). This implicitly assumes that the gains accruing from an overall optimization exceed the costs incurred because

of the full harmonization and integrated control of the TSOs.

3.3.4 Counter-trading is decentralised

The second arrangement takes place when the two TSOs retain separate operations, but share common constraints or resources. The capacities of the lines joining the Northern and Southern zones are common constraints used by both TSOs. They can be priced or not depending on whether one introduces a market for transmission at the counter-trading level or not. We want to check the impact of this pricing on the overall efficiency of counter-trading. Common economic sense indeed suggests that the inception of a transmission capacity market increases efficiency. Counter-trading resources at the generator or consumer levels are the other set of resources. They may be shared by the two TSOs or not depending on the organisation. When shared, we assume, in compliance with general non discrimination principles that both TSOs access them at the same price. We distinguish three extents of sharing counter-trading resources. A first situation is the one where there is effectively an internal market for counter-trading resources: both TSOs can have access to all incremental and decremental injections in both zones. A second case is the one where this common market exists, but is limited by quantitative constraints that are interpreted in terms of security: a TSO can only access part of the counter-trading resources of the other zone. The third situation occurs when there is no common market for counter-trading resources. We also want to assess the impact of these different organisations on the overall efficiency of counter-trading. We here present the structure of the model and refer to a companion paper [9] for a broader analysis of numerical results.

3.3.5 Note on counter-trading costs

Re-dispatching costs interact with the PX's bids and create a link between the market coupling and counter-trading problems. This is not discussed here, but illustrated in a companion paper (see [9]). For the sake of readability we report the average counter-trading cost α because it is easy to interpret and compare to the energy price. It is obtained by dividing the total counter-trading cost (TCC) that varies with the model considered by the total generation ($\sum_{i=1,2,4} q_i$). This is defined as follows:

$$\alpha = \frac{TCC}{\sum_{i=1,2,4} q_i}$$

4 Modelling

The original NTF paper is stated in terms of variational inequality problems; our example deals with variational inequality models that are integrable into optimization problems. We therefore only refer to optimization models, using the following nomenclature:

Sets

- $l=(1-6);(2-5)$: Lines with limited capacity;
- $n = 1, 2, 3, 4, 5, 6$: Nodes
- $i(n) = 1, 2, 4$: Subet of production nodes;
- $j(n) = 3, 5, 6$: Subet of consumption nodes

Parameters

- $PTDF_{l,n}$: Power Transfer Distribution Factor (PTDF) matrix of node n on line l ;
- \bar{F}_l : Limit of flow through lines $l = (1 - 6); (2 - 5)$;
- q_n : Power traded (bought or sold) in node n (MWh); these are determined in the market coupling problem and are taken as data in the counter-trading models.

Variables

- Δq_n : Counter-trading variables: Incremental or decremental quantities of electricity with respect to q_n (MWh).

We assume that all agents are price takers. They bid in both the day-ahead and counter-trading markets. We do not separately model a balancing market taking care of deviations with respect to day-ahead.

4.1 Counter-trading operations are optimized

Assume that TSO^N and TSO^S buy incremental and decremental quantities of electricity Δq_n in their domestic market ($N = (1, 2, 3)$ and $S = (4, 5, 6)$ respectively) and coordinate operations to remove congestion at the minimal counter-trading cost. This is stated in the optimization problem (59)-(65).

The global re-dispatching costs appears in the objective function (59). There are two classes of constraints. The first class involves both TSOs and includes the balance equations (60), (61) and the transmission capacity constraints (62) and (63). Conditions (60) and (61) impose that the sum of the incremental injections ($\Delta q_{i=1,2,4}$) and withdrawals ($\Delta q_{j=3,5,6}$) equals zero. This expresses that the amount of energy cleared by the PX is not affected by counter-trading. As alluded to before, this rule separates the trading of energy (the q_n that remain unchanged) and the counter-trading operations (the Δq_n variables that are counter-trading operations) in two different markets. The dual variables λ_l^\pm associated with (62) and (63) respectively define the marginal values of the capacited lines (1-6) and (2-5) in the two flow directions. Because there is a single optimization problem for both TSOs, they see the same value for the congested lines. In the second class, we group constraints (64)-(65) that are specific to the geographic zone covered by each TSO.

The non-negativity constraints (64) state that the quantities of electricity demanded and produced in the Northern zone plus the incremental and decremental injections of the TSO^N have to be non-negative. An identical reasoning applies in condition (65) for the zone covered by TSO^S.

$$\mathbf{Min}_{\Delta q_n} \quad \sum_{i=1,2,4} \int_{q_i}^{q_i+\Delta q_i} c_i(\xi) d\xi - \sum_{j=3,5,6} \int_{q_j}^{q_j+\Delta q_j} w_j(\xi) d\xi \quad (59)$$

s.t.

$$\sum_{i=1,2,4} \Delta q_i + \sum_{j=3,5,6} \Delta q_j = 0 \quad (\mu^1) \quad (60)$$

$$\sum_{i=1,2,4} \Delta q_i - \sum_{j=3,5,6} \Delta q_j = 0 \quad (\mu^2) \quad (61)$$

$$\bar{F}_l - \left[\sum_{i=1,2,4} PTDF_{i,l}(q_i + \Delta q_i) - \sum_{j=3,5,6} PTDF_{j,l}(q_j + \Delta q_j) \right] \geq 0 \quad (\lambda_l^+) \quad (62)$$

$$\bar{F}_l + \left[\sum_{i=1,2,4} PTDF_{i,l}(q_i + \Delta q_i) - \sum_{j=3,5,6} PTDF_{j,l}(q_j + \Delta q_j) \right] \geq 0 \quad (\lambda_l^-) \quad (63)$$

$$q_n + \Delta q_n \geq 0 \quad n = 1, 2, 3 \quad (\nu_n^N) \quad (64)$$

$$q_n + \Delta q_n \geq 0 \quad n = 4, 5, 6 \quad (\nu_n^S) \quad (65)$$

Problem (59)-(65) is strictly convex and admits a unique solution. This model provides the benchmark for evaluating other organizations of counter-trading. Finally, the average re-dispatching costs α is computed by dividing the objective function (59) by $\sum_{i=1,2,4} q_i$.

4.2 Decentralized counter-trading Model 1: TSO^N and TSO^S have full access to all re-dispatching resources

TSO^N and TSO^S no longer cooperate for removing network congestion, but still have full access to all counter-trading resources of the system. This means that a TSO can buy and sell incremental and decremental injections and withdrawals in the control area of the other TSO (e.g. TSO^N can also counter-trade in the Southern zone and vice versa). This situation can be interpreted as the creation of an internal market of counter-trading resources. Denoting the counter-trading variables of the Northern and Southern TSOs respectively as $\Delta q_{n=1,\dots,6}^N$ and $\Delta q_{n=1,\dots,6}^S$, the following presents the problem of TSO^N, the problem of TSO^S is similar and given in Appendix C.

4.2.1 Problem of TSO^N

TSO^N solves the optimization problem (66)-(71). It minimizes its re-dispatching costs (66) taking into account its balance constraints (67) and (68) (each TSO must remain in balance) and the counter-trading actions of the other TSO. These actions appear in the transmission constraints (69)-(70), and the overall non-negativity constraint (71) on generation and consumption. Note

that constraints (67) and (68) are specific to the single Northern TSO while (69)-(70), and (71) involve both TSOs.

$$\mathbf{Min}_{\Delta q_n^N} \quad \sum_{i=1,2,4} \int_{q_i + \Delta q_i^S}^{q_i + \Delta q_i^S + \Delta q_i^N} c_i(\xi) d\xi - \sum_{j=3,5,6} \int_{q_j + \Delta q_j^S}^{q_j + \Delta q_j^S + \Delta q_j^N} w_j(\xi) d\xi \quad (66)$$

s.t.

$$\sum_{i=1,2,4} \Delta q_i^N + \sum_{j=3,5,6} \Delta q_j^N = 0 \quad (\mu^{N,1}) \quad (67)$$

$$\sum_{j=3,5,6} \Delta q_j^N - \sum_{i=1,2,4} \Delta q_i^N = 0 \quad (\mu^{N,2}) \quad (68)$$

$$\bar{F}_l - \left[\sum_{i=1,2,4} PTDF_{i,l}(q_i + \Delta q_i^N + \Delta q_i^S) - \sum_{j=3,5,6} PTDF_{j,l}(q_j + \Delta q_j^S + \Delta q_j^N) \right] \geq 0 \quad (\lambda_l^{N,+}) \quad (69)$$

$$\bar{F}_l + \left[\sum_{i=1,2,4} PTDF_{i,l}(q_i + \Delta q_i^N + \Delta q_i^S) - \sum_{j=3,5,6} PTDF_{j,l}(q_j + \Delta q_j^S + \Delta q_j^N) \right] \geq 0 \quad (\lambda_l^{N,-}) \quad (70)$$

where $l = (1 - 6), (2 - 5)$

$$q_n + \Delta q_n^N + \Delta q_n^S \geq 0 \quad \forall n \quad (\nu_n^N) \quad (71)$$

4.2.2 An efficient Generalized Nash Equilibrium

The combination of both TSOs' problems suggests a Generalized Nash Equilibrium model that we want to interpret in terms of markets for counter-trading resources and transmission capacities.

A first step towards the creation of an internal market of counter-trading resources is that both TSO^N and TSO^S have access to the same incremental and decremental injections and withdrawals. This is stated in the constraints (67)-(68) of the TSO^N and (114)-(115) of the TSO^S's problems (see Appendix C). The intended effect is that this access should be at the same price for both TSOs. This remains to be proved. One may also wish to create a market of transmission capacities. This is expressed by the constraints imposed on the dual variables of constraints (71) for TSO^N and the analogous constraint for TSO^S. Imposing the equality of these dual variables amounts to assume a market of transmission capacities as both TSOs see the same price for transmission resources. In contrast, there is no market for line capacity in the counter-trading system if the dual variables of (69)-(70) for TSO^N and (116)-(117) for TSO^S can be different.

The two assumptions of transmission market can be easily cast in the *NTF* parametrized optimization problem (72)-(80) (a parametrized *VI* problem in general). The objective function (72) combines the actions of both TSOs and also includes the parameters⁵ $\gamma^{N,S,\pm}$ that perturb

⁵The apices N,S of the parameters $\gamma^{N,S,\pm}$ indicate "North" and "South"; while the sign "+" and "-" indicate the flow directions. The positive direction is from the Northern to the Southern zone; the negative direction is from the Southern to the Northern zone.

the dual variables λ_l^+ and λ_l^- associated with the common transmission constraints (77) and (78). Setting the $\gamma^{N,S,\pm}$ to zero implies equal dual variables of the transmission constraints and hence a transmission market. Setting them at different values represents the case where there is no transmission market. While (77) and (78) are common to TSO^N and TSO^S, the balance conditions (73), (74), (75) and (76) apply to each individual TSO. Conditions (73)-(74) are identical to (67)-(68) and refer to TSO^N, while (75) and (76) regard TSO^S (compare (114) and (115) in Appendix C).

$$\begin{aligned} \text{Min}_{\Delta q_{\text{in}}^{N,S}} \quad & \sum_{i=1,2,4} \int_{q_i}^{q_i + \Delta q_i^N + \Delta q_i^S} c_i(\xi) d\xi - \sum_{j=3,5,6} \int_{q_j}^{q_j + \Delta q_j^N + \Delta q_j^S} w_j(\xi) d\xi + \quad (72) \\ & + (\gamma_l^{N,+} - \gamma_l^{N,-}) \cdot \left(\sum_{i=1,2,4;l} PTDF_{i,l} \cdot \Delta q_i^N - \sum_{j=3,5,6;l} PTDF_{j,l} \cdot \Delta q_j^N \right) \\ & + (\gamma_l^{S,+} - \gamma_l^{S,-}) \cdot \left(\sum_{i=1,2,4;l} PTDF_{i,l} \cdot \Delta q_i^S - \sum_{j=3,5,6;l} PTDF_{j,l} \cdot \Delta q_j^S \right) \end{aligned}$$

s.t.

$$\sum_{i=1,2,4} \Delta q_i^N + \sum_{j=3,5,6} \Delta q_j^N = 0 \quad (\mu^{N,1}) \quad (73)$$

$$\sum_{j=3,5,6} \Delta q_j^N - \sum_{i=1,2,4} \Delta q_i^N = 0 \quad (\mu^{N,2}) \quad (74)$$

$$\sum_{i=1,2,4} \Delta q_i^S + \sum_{j=3,5,6} \Delta q_j^S = 0 \quad (\mu^{S,1}) \quad (75)$$

$$\sum_{j=3,5,6} \Delta q_j^S - \sum_{i=1,2,4} \Delta q_i^S = 0 \quad (\mu^{S,2}) \quad (76)$$

$$\bar{F}_l - \left[\sum_{i=1,2,4} PTDF_{i,l}(q_i + \Delta q_i^N + \Delta q_i^S) - \sum_{j=3,5,6} PTDF_{j,l}(q_j + \Delta q_j^N + \Delta q_j^S) \right] \geq 0 \quad (\lambda_l^+) \quad (77)$$

$$\bar{F}_l + \left[\sum_{i=1,2,4} PTDF_{i,l}(q_i + \Delta q_i^N + \Delta q_i^S) - \sum_{j=3,5,6} PTDF_{j,l}(q_j + \Delta q_j^N + \Delta q_j^S) \right] \geq 0 \quad (\lambda_l^-) \quad (78)$$

where $l = (1 - 6), (2 - 5)$

$$q_n + \Delta q_n^N + \Delta q_n^S \geq 0 \quad \forall n \quad (\nu_n^N) \quad (79)$$

$$q_n + \Delta q_n^N + \Delta q_n^S \geq 0 \quad \forall n \quad (\nu_n^S) \quad (80)$$

While the above formulation accounts for the fact that both TSOs have access to the same counter-trading resources (balance conditions (73), (74), (75) and (76)), it does not imply yet that they see the same prices for them as one would expect in an internal market of these resources. This relation is established in the following propositions.

Proposition 1 Denote transmission constraints (77) and (78) respectively as g_l^+ and g_l^- . Suppose that $\langle g_l^+(x^*), \gamma_l^{N/S,+} \rangle = 0$ and $\langle g_l^-(x^*), \gamma_l^{N/S,-} \rangle = 0$. The solution of problem (72)-(80) is a GNE if and only if $\gamma_l^{N,+} = \gamma_l^{S,+}$ and $\gamma_l^{N,-} = \gamma_l^{S,-}$.

Proof 1 See Appendix E. ■

The implication of this proposition is that a GNE solution of this problem, if it exists, has identical dual variables for the transmission constraints. This amounts to creating a market of transmission resources. It also implies a single price for counter-trading resources thereby completing the proof that we did create an internal market of these resources. This is stated in the following proposition.

Proposition 2 The solution of the GNE problem (72)-(80), if it exists satisfies $\lambda_l^{N,\pm} = \lambda_l^{S,\pm}$; $\mu^{N,1} = \mu^{S,1}$ and $\mu^{N,2} = \mu^{S,2}$.

Proof 2 See Appendix F. ■

The interpretation of this second proposition is twofold. From a mathematical point of view it expresses that the solution set of the QVI associated to this GNE problem is identical to the solution set of the related VI problem. This identifies a class of problems for which the solutions sets of the QVI and VI are identical. The economic interpretation of that problem is that introducing a common access to counter-trading resources, implicitly implies the existence of a market for transmission resources and an internal (non discriminatory) market of counter-trading resources. In other words, an internal market of counter-trading resources “completes” the market.

The next implication is an expected result. A complete market is efficient; the outcome should be identical to the one of the full optimization of counter-trading. This also proves that the solution of the GNE (72)-(80), if it exists, is unique. This is expressed in the following corollaries.

Corollary 1 Suppose the solution to coordinated counter-trading problem (59)-(65) exists. Then, the solution of the GNE problem (72)-(80) exists and coincides with that of the coordinated counter-trading problem (59)-(65).

Proof 3 See Appendix G. ■

Corollary 2 The solution of the GNE problem (72)-(80) is unique.

Proof 4 Since the solution to problem (59)-(65) is unique (see Section 4.1), thanks to Corollary 1, we can immediately conclude that the solution to problem (72)-(80) is unique too. ■

4.3 Decentralized counter-trading Model 2: TSO^N and TSO^S have limited access to part of the counter-trading resources

4.3.1 A partial market of counter-trading resources

The model presented in Section 4.2 assumes that both TSOs have full access to all re-dispatching resources. We depart from this assumption here and model the case where both TSO^N and TSO^S have a limited access to the counter-trading resources located outside of their control area. This means that the Northern TSO's purchase of Southern counter-trading resources is limited and conversely. The optimization problems of each TSO are immediately derived from those in Section 4.2 by adding upper and lower constraints on the variables defining re-dispatching in the zone not directly controlled by this TSO. We do not report these individual optimization problems here, but directly present the model in the Nabetani, Tseng and Fukushima's form. The additional constraints (86) and (87) impose the upper and lower bounds on the actions of two TSOs in the jurisdiction that is not under their direct control. Condition (86) limits the TSO^N's purchase of Southern counter-trading resources and condition (87) does the same for TSO^S in the Northern zone. This arrangement is likely to be more realistic ("pragmatic" in usual parlance) than the above creation of an internal market: TSOs that are not integrated will probably insist on keeping resources under their sole control. We shall see that giving up the internal market of counter-trading resources can have dramatic consequences. We discuss these consequences in principle in this paper together with some numerical results. We further elaborate on these numerical results in our companion paper (see [9]).

4.3.2 Inefficient Generalized Nash Equilibrium

Let $\overline{\Delta q_n^N}$ and $\overline{\Delta q_n^S}$ be respectively the bounds (in absolute value) imposed on TSOs resorting to outside resources. The other conditions and constraints are as in Section 4.2. The NTS problem is stated as follows:

$$\begin{aligned} \mathbf{Min}_{\Delta q_{in}^{N,S}} \quad & \sum_{i=1,2,4} \int_{q_i}^{q_i + \Delta q_i^S + \Delta q_i^N} c_i(\xi) d\xi - \sum_{j=3,5,6} \int_{q_j}^{q_j + \Delta q_j^S + \Delta q_j^N} w_j(\xi) d\xi + \quad (81) \\ & + (\gamma_l^{N,+} - \gamma_l^{N,-}) \cdot \left(\sum_{i=1,2,4;l} PTDF_{i,l} \cdot \Delta q_i^N - \sum_{j=3,5,6;l} PTDF_{j,l} \cdot \Delta q_j^N \right) \\ & + (\gamma_l^{S,+} - \gamma_l^{S,-}) \cdot \left(\sum_{i=1,2,4;l} PTDF_{i,l} \cdot \Delta q_i^S - \sum_{j=3,5,6;l} PTDF_{j,l} \cdot \Delta q_j^S \right) \end{aligned}$$

s.t.

$$\sum_{i=1,2,4} \Delta q_i^N + \sum_{j=3,5,6} \Delta q_j^N = 0 \quad (\mu^{N,1}) \quad (82)$$

$$\sum_{j=3,5,6} \Delta q_j^N - \sum_{i=1,2,4} \Delta q_i^N = 0 \quad (\mu^{N,2}) \quad (83)$$

$$\sum_{i=1,2,4} \Delta q_i^S + \sum_{j=3,5,6} \Delta q_j^S = 0 \quad (\mu^{S,1}) \quad (84)$$

$$\sum_{j=3,5,6} \Delta q_j^S - \sum_{i=1,2,4} \Delta q_i^S = 0 \quad (\mu^{S,2}) \quad (85)$$

$$-\overline{\Delta q_n^N} \leq \Delta q_n^N \leq \overline{\Delta q_n^N} \quad n = 4, 5, 6 \quad (\eta_n^{N,\pm}) \quad (86)$$

$$-\overline{\Delta q_n^S} \leq \Delta q_n^S \leq \overline{\Delta q_n^S} \quad n = 1, 2, 3 \quad (\eta_n^{S,\pm}) \quad (87)$$

$$\bar{F}_l - \left[\sum_{i=1,2,4} PTDF_{i,l}(q_i + \Delta q_i^N + \Delta q_i^S) - \sum_{j=3,5,6} PTDF_{j,l}(q_j + \Delta q_j^S + \Delta q_j^N) \right] \geq 0 \quad (\lambda_l^+) \quad (88)$$

$$\bar{F}_l + \left[\sum_{i=1,2,4} PTDF_{i,l}(q_i + \Delta q_i^N + \Delta q_i^S) - \sum_{j=3,5,6} PTDF_{j,l}(q_j + \Delta q_j^S + \Delta q_j^N) \right] \geq 0 \quad (\lambda_l^-) \quad (89)$$

where $l = (1 - 6), (2 - 5)$

$$q_n + \Delta q_n^N + \Delta q_n^S \geq 0 \quad \forall n \quad (\nu_n^N) \quad (90)$$

$$q_n + \Delta q_n^N + \Delta q_n^S \geq 0 \quad \forall n \quad (\nu_n^S) \quad (91)$$

The following proposition is a preliminary; it gives the condition for the existence of Generalized Nash Equilibrium and is a direct application of the NTF results.

Proposition 3 Denote transmission constraints (88) and (89) respectively by g_l^+ and g_l^- . Suppose that $\langle g_l^+(x^*), \gamma_l^{N/S,+} \rangle = 0$ and $\langle g_l^-(x^*), \gamma_l^{N/S,-} \rangle = 0$. If the solution to problem (81)-(91) exists, it is a GNE.

Proof 5 The proof is a direct application of NTF's Theorem 3.3 (see [7]). ■

In contrast with the case of the internal market of counter-trading resources, the outcome of the market is here ambiguous: there may be several GNEs and they may differ in terms of efficiency. We first state that we fall back on the case of the internal market of counter-trading resources (decentralized Model 1) if none of the quantitative restrictions of cross zonal resources is binding. This means that the resources remaining of the exclusive control of the zonal TSO are not too important.

Proposition 4 Denote transmission constraints (88) and (89) respectively as to g_l^+ and g_l^- . Suppose that $\langle g_l^+(x^*), \gamma_l^{N/S,+} \rangle = 0$ and $\langle g_l^-(x^*), \gamma_l^{N/S,-} \rangle = 0$. If the solution to problem (81)-(91) exists and no cross zonal counter-trading resource is binding, then $\gamma_l^{N,+/-} = \gamma_l^{S,+/-}$ and the GNE is unique and identical to the solution of the optimized counter-trading.

Proof 6 Apply the proof of Appendix E after noting that the KKT conditions of problem (72)-(80) are identical to those of problem (81)-(91) when cross zonal quantitative restrictions are not binding. ■

As expected, things change when some of the cross zonal quantitative restrictions are binding. The following proposition states that the solution of the *GNE* (81)-(91), if it exists, is not unique when some of the quantitative limitations on counter-trading resources are binding.

Proposition 5 *Suppose that a GNE obtained by solving (81)-(91) has some cross zonal restrictions binding. The valuation of the transmission capacities by both agents are identical when all $\gamma_l^{N/S,+/-}$ are zero and the solution always satisfies $\lambda_l^{N,-} - \lambda_l^{S,-} = \gamma_l^{N,-} - \gamma_l^{S,-}$ and $\lambda_l^{N,+} - \lambda_l^{S,+} = \gamma_l^{N,+} - \gamma_l^{S,+}$.*

Proof 7 *See Appendix I. ■*

This proposition disentangles the impact of two market incompletenesses. Setting all γ to zero creates a market for transmission capacities even in the absence of a market of counter-trading resources. This is a step in the right direction: a transmission market does not restore the full efficiency of counter-trading, but it improves it. The absence of a transmission market can lead to different inefficient outcomes. These can be obtained by introducing a wedge between γ different from zero (while verifying that the conditions $\langle g_l^+(x^*), \gamma_l^{N/S,+} \rangle = 0$ and $\langle g_l^-(x^*), \gamma_l^{N/S,-} \rangle = 0$ for a *GNE* are maintained). This is illustrated in the numerical results through further examples and expanded in our companion paper (see [9]).

Last it may be useful to recall that counter-trading is not always possible.

Corollary 3 *The solution of the GNE problem does not necessarily exist.*

Proof 8 *It suffices to take a case where the NTF problem is infeasible. ■*

4.4 Decentralized counter-trading Model 3: TSO^N and TSO^S operate only in their own control area

4.4.1 A segmented market of counter-trading resources

This section presents a more extreme situation. The following model, directly presented in the Nabetani, Tseng and Fukushima's formulation, describes a transmission market where each TSO manages the re-dispatching resources of its own area only, taking as given the action of the other TSO. There is no additional transaction from a TSO into the other TSO zone.

The problem is formulated through relations (92) to (100). The objective function (92) globalizes the counter-trading costs of the two TSOs. This problem is subject to the shared transmission constraints (97)-(98) and the balance constraints of TSO^N ((93) and (94)) and TSO^S ((95) and (96)).

$$\mathbf{Min}_{\Delta q_n^{N,S}} \quad \sum_{i=1,2} \int_{q_i}^{q_i + \Delta q_i^N} c_i(\xi) d\xi - \sum_{j=3} \int_{q_j}^{q_j + \Delta q_j^N} w_j(\xi) d\xi + \quad (92)$$

$$\begin{aligned}
& + \sum_{i=4} \int_{q_i}^{q_i + \Delta q_i^S} c_i(\xi) d\xi - \sum_{j=5,6} \int_{q_j}^{q_j + \Delta q_j^S} w_j(\xi) d\xi + \\
& + (\gamma_l^{N,+} - \gamma_l^{N,-}) \cdot \left(\sum_{i=1,2;l} PTDF_{i,l} \cdot \Delta q_i^N - \sum_{j=3;l} PTDF_{j,l} \cdot \Delta q_j^N \right) \\
& + (\gamma_l^{S,+} - \gamma_l^{S,-}) \cdot \left(\sum_{i=4;l} PTDF_{i,l} \cdot \Delta q_i^S - \sum_{j=5,6;l} PTDF_{j,l} \cdot \Delta q_j^S \right)
\end{aligned}$$

s.t.

$$\Delta q_3^N + \Delta q_1^N + \Delta q_2^N = 0 \quad (\mu^{N,1}) \quad (93)$$

$$\Delta q_3^N - \Delta q_1^N - \Delta q_2^N = 0 \quad (\mu^{N,2}) \quad (94)$$

$$\Delta q_5^S + \Delta q_6^S + \Delta q_4^S = 0 \quad (\mu^{S,1}) \quad (95)$$

$$\Delta q_5^S + \Delta q_6^S - \Delta q_4^S = 0 \quad (\mu^{S,2}) \quad (96)$$

$$\bar{F}_l - \left[\sum_{i=1,2} PTDF_{i,l}(q_i + \Delta q_i^N) + \sum_{i=4} PTDF_{i,l}(q_i + \Delta q_i^S) - \sum_{j=3} PTDF_{j,l}(q_j + \Delta q_j^N) \right] \quad (97)$$

$$- \sum_{j=5,6} PTDF_{j,l}(q_j + \Delta q_j^S) \geq 0 \quad (\lambda_l^+)$$

$$\bar{F}_l + \left[\sum_{i=1,2} PTDF_{i,l}(q_i + \Delta q_i^N) + \sum_{i=4} PTDF_{i,l}(q_i + \Delta q_i^S) - \sum_{j=3} PTDF_{j,l}(q_j + \Delta q_j^N) \right] \quad (98)$$

$$- \sum_{j=5,6} PTDF_{j,l}(q_j + \Delta q_j^S) \geq 0 \quad (\lambda_l^-)$$

where $l = (1 - 6), (2 - 5)$

$$q_n + \Delta q_n^N \geq 0 \quad n = 1, 2, 3 \quad (\nu_n^N) \quad (99)$$

$$q_n + \Delta q_n^S \geq 0 \quad n = 4, 5, 6 \quad (\nu_n^S) \quad (100)$$

Re-dispatching costs are then truly zonal: the average counter-trading cost in the Northern area is:

$$\alpha^N = \frac{(\sum_{i=1,2} \int_{q_i^t}^{q_i + \Delta q_i^N} c_i(\xi) d\xi - \sum_{j=3} \int_{q_j}^{q_j + \Delta q_j^N} w_j(\xi) d\xi)}{q_1 + q_2}$$

with a similar formula for the Southern area. A “global” average-dispatching cost can also be determined by dividing the the total re-dispatching costs $(\sum_{i=1,2} \int_{q_i^t}^{q_i + \Delta q_i^N} c_i(\xi) d\xi - \int_{q_3}^{q_3 + \Delta q_3^N} w_3(\xi) d\xi + \int_{q_4}^{q_4 + \Delta q_4^S} c_4(\xi) d\xi - \sum_{j=5,6} \int_{q_j}^{q_j + \Delta q_j^S} w_j(\xi) d\xi)$ by $\sum_{i=1,2,4} \cdot q_i$

4.4.2 Further inefficient Generalized Nash Equilibrium

The following propositions are particular cases of those obtained in the preceding section. The first statement again directly obtains from NTF's results: it simply states the conditions under which the solution of this problem is a *GNE*.

Proposition 6 *Denote transmission constraints (97) and (98) respectively by g_l^+ and g_l^- . Suppose that $\langle g_l^+(x^*), \gamma_l^{N/S,+} \rangle = 0$ and $\langle g_l^-(x^*), \gamma_l^{N/S,-} \rangle = 0$. If the solution to problem (92) to (100) exists, it is a *GNE*.*

Proof 9 *The proof is a direct application of NTF's Theorem 3.3 (see [7]). ■*

There is no market of counter-trading resources in this case and there may thus be different *GNEs*. The following proposition states that the *GNE* solution of the (92) to (100), if it exists, is not unique.

Proposition 7 *Suppose a *GNE* obtained by solving (92) to (100) exist. The valuation of the transmission capacities by both agents are identical when all $\gamma_l^{N/S,+/-}$ are zero and the solution always satisfies $\lambda_l^{N,-} - \lambda_l^{S,-} = \gamma_l^{N,-} - \gamma_l^{S,-}$ and $\lambda_l^{N,+} - \lambda_l^{S,+} = \gamma_l^{N,+} - \gamma_l^{S,+}$.*

Proof 10 *See Appendix K. ■*

These comments are parallel to those of Section 4.3.2. As already explained before setting all γ to zero creates a market for transmission capacities that can only improve efficiency even without an internal market of counter-trading resources. One can assess the range of possible inefficiencies by introducing a wedge between the valuations of the transmission constraints using the γ of the TSOs.

Last we again recall that there may not exist a *GNE* because counter-trading is not possible.

Corollary 4 *The solution of the *GNE* problem does not necessarily exist.*

Proof 11 *It suffices to take a case where the *NFT* problem is infeasible. ■*

5 Results

This section illustrates the different models of counter-trading starting from injections as reported in Table 6. These are obtained by solving a market coupling problem of the type described in Appendix A. The reader is referred to Oggioni and Smeers [9] for more details on this problem.

q_1	q_2	q_3	q_4	q_5	q_6
366.667	266.667	183.333	166.667	283.333	333.333

Table 6: Nodal demand and generation (MWh)

5.1 Optimized counter-trading

The optimization of counter-trading refers to an organization where TSOs fully cooperate to relieve congestion. Applying this principle to the network depicted in Figure 1 we find a counter-trading cost of 1,145.833 €, which in average amounts to 1.432 €/MWh. The re-dispatched quantities are indicated in Table 7; there is a net counter-trading flow from South to North equal to 50 MWh. Line (1-6) is congested in the North-South direction and its marginal value is 40 €/MWh.

Δq_1	Δq_2	Δq_3	Δq_4	Δq_5	Δq_6
-66.666	33.333	16.666	33.333	16.666	-33.333

Table 7: Re-dispatching quantities (MWh)

As we will see in the following, the coordinated counter-trading model is relatively efficient. Because it is a cooperative solution, some regions may be better off by not participating. We do not deal with that question and assume that market operators are able to re-distribute resources among market players in such a way that no player or zone is worse off than by not participating.

5.2 Decentralized counter-trading Model 1: TSOs have full access to all counter-trading resources

Assume that TSO^N and TSO^S can access all counter-trading resources. Setting all “ $\gamma_l^{N,S,\pm}$ ” equal to zero (compare to the model discussed in Section 4.2), the problem can be interpreted as a market where both TSOs equally value capacities; this simulates a market of transmission capacities. Numerically, we fall back to the solution of the optimized counter-trading problem. Applying different “ $\gamma_l^{N,S,\pm}$ ” with the view of testing different valuations of transmission capacities, and hence the absence of a transmission market, always leads to unbounded NTF problems. There is no primal dual solution to the NTF problem and hence no *GNE*. This complies with the theory: as stated in Section 4.2.2 an internal market of counter-trading resources implies a market of transmission capacities.

The value of the dual variable of line (1-6) in the model where all “ $\gamma_l^{N,S,\pm}$ ” are equal to zero is 40 €/MWh in the positive direction North-South. One can thus expect that taking $\gamma_{(1-6)}^{N,+} = \gamma_{(1-6)}^{S,+} = 40$ leads again to the solution of the optimized counter-trading, but with the dual variables of the transmission constraints all equal to zero. Re-dispatching quantities are given in Table 7.

The sole important figure is the total (the sum over the two TSOs) re-dispatching; the allocation of this total between the two agents is arbitrary.

5.3 Imperfectly coordinated counter-trading Model 2: TSO^N and TSO^S have limited access to part of the counter-trading resources

The situation changes when we constraint the access of a TSO to counter-trading resources in the other jurisdiction. Suppose limits of one TSO's access to resources in the other zone as given in Table 8. These are selected by halving the counter-trading flows from South to North obtained for optimized counter-trading (compare Table 7). Taking into account these limits, we run five cases that differ by the values assigned to the parameters " $\gamma_l^{N/S,\pm}$ ". Results are reported in Table 9. Recall that α defines the average counter-trading cost. The bottom of Table 9 reports the total counter-trading costs (TCC) and the counter-trading costs of the two TSOs. The other row names are self explanatory.

$\bar{\Delta}q_1^S$	$\bar{\Delta}q_2^S$	$\bar{\Delta}q_3^S$	$\bar{\Delta}q_4^N$	$\bar{\Delta}q_5^N$	$\bar{\Delta}q_6^N$
33.333	16.666	8.333	16.666	8.333	16.666

Table 8: Limits on the action of the two TSOs (MWh)

These different cases are meant to produce different Generalized Nash Equilibria. Cases 1 and 2 are obtained with equal γ for the two TSOs and hence represent the impact of a market of transmission capacities. The constraints on cross zonal access to resources are not binding and the solution is identical to the one of the optimized counter-trading. The policy implication of this finding is interesting: this case allows individual TSOs to retain the exclusive control on some of their plants, which is a limitation to the internal market of counter-trading resources. But the creation of a transmission market overcomes the negative consequences of that limitation and allows one to restore efficiency. The other cases assume TSOs with different γ , therefore modeling the absence of a transmission market. This leads to different phenomena.

Supposes first that the sole $\gamma_{(1-6)}^{N,+}$ is positive and equal to 40 (case 3). There is no transmission market, which creates another *GNE*. Different valuations of the common line (1-6) capacity signal economic inefficiencies as can be seen by the increase of 164.773 € of the re-dispatching costs compared to Case 1. The average re-dispatching cost becomes 1.638 €/MWh. The result of the counter-trading activity is a net flow of 36.364 MWh going from South to North. TSO^N's re-dispatching costs amount to 1,454.077 €, while TSO^S benefits from the operations as can be seen from its negative re-dispatching costs. Again, line (1-6) is congested and its marginal value becomes 42.424 €/MWh; this increase with respect to the 40 observed in the optimal counter-trading reflects the inefficiency created by the absence of the transmission market.

Consider now the alternative arrangement where we impose $\gamma_{(1-6)}^{S,+} = 40$ (case 4). The counter-trading flow from South to North is of 43.284 MWh. This case is more efficient than Case 3,

	Case 1	Case 2	Case 3	Case 4	Case 5
$\gamma_{(1-6)}^{N,+}$	0.000	40.000	40.000	0.000	80.000
$\gamma_{(2-5)}^{N,+}$	0.000	0.000	0.000	0.000	0.000
$\gamma_{(1-6)}^{S,+}$	0.000	40.000	0.000	40.000	20.000
$\gamma_{(2-5)}^{S,+}$	0.000	0.000	0.000	0.000	0.000
MV line (1-6)	40.000	0.000	42.424	40.995	22.667
α (€/MWh)	1.432	1.432	1.638	1.535	1.862
CC^N (€)	722.198	763.860	1,454.077	-236.485	1,796.357
CC^S (€)	423.640	381.970	-143.470	1,464.408	-306.769
TCC (€)	1,145.833	1,145.833	1,310.606	1,227.923	1,489.588

Table 9: $\gamma_i^{N/S,\pm}$ values, Marginal Value (MV) of congested line (1-6), average re-dispatching cost (α) and TSOs' counter-trading costs in different cases

but counter-trading costs are still higher than in Case 1. In contrast with Case 3, TSO^N now gains from counter-trading, while TSO^S incurs additional re-dispatching costs. Line (1-6) is still congested with a marginal value of 40.995 €/MWh (slightly higher than the 40 €/MWh of the optimal counter-trading).

Case 5 shows the worst degradation of all. The γ of the TSOs relative to line (1-6) are indicated in Table 9. Global re-dispatching costs amount to 1,489.588 €. TSO^N incurs most of this cost while TSO^S still benefits. The net re-dispatch amounts to 30 MWh from South to North. The marginal value of line (1-6) is now 22.667 €/MWh.

5.4 Imperfectly coordinated counter-trading Model 3: TSOs control the counter-trading resources of their area only

Going one step further, suppose that TSOs remove congestion on the interconnection by only acquiring counter-trading resources in their jurisdiction. In other words, re-dispatching quantities sum to zero in each zone and there is no exchange of re-dispatching resources between the two zones.

This should increase inefficiency; we consider different cases and report the results in Table 10. " $\gamma_i^{N,S,\pm}$ " are all equal to zero in Case 1. Recall that this simulates a transmission market. Inefficiency is highlighted by significant re-dispatching costs of 2,520.833 € with average value of 3.151 €/MWh. Both TSOs counter-trade and TSO^N face the highest cost. Line (1-6) is congested in the positive direction and has a marginal value of 146.667 €/MWh! Parallel to what we did for the un-coordinated counter-trading Models 1 and 2, we also consider the case where $\gamma_{(1-6)}^{N,+} = \gamma_{(1-6)}^{S,+} = 146.667$. This is Case 2 reported in Table 10. Attributing this particular value to the γ of both TSOs, we get again the results of Case 1, even though the dual variable of line (1-6) capacity falls to zero.

	Case 1	Case 2	Case 3	Case 4	Case 5
$\gamma_{(1-6)}^{N,+}$	0.000	146.667	146.667	0.000	102.667
$\gamma_{(2-5)}^{N,+}$	0.000	0.000	0.000	0.000	0.000
$\gamma_{(1-6)}^{S,+}$	0.000	146.667	0.000	146.667	44.000
$\gamma_{(2-5)}^{S,+}$	0.000	0.000	0.000	0.000	0.000
MV line (1-6)	146.667	0.000	48.889	97.778	63.555
α (€/MWh)	3.151	3.151	3.851	3.851	3.263
CC^N (€)	1,680.556	1,680.556	2,987.658	746.912	2,158.581
CC^S (€)	840.278	840.278	93.363	2,334.109	451.882
TCC (€)	2,520.833	2,520.833	3,081.021	3,081.021	2,610.463

Table 10: $\gamma_i^{N/S,\pm}$ values, Marginal Value (MV) of congested line (1-6), average re-dispatching cost (α) and TSOs' counter-trading costs in different cases

We further degrade the situation in Cases 3 and 4 that respectively assume $\gamma_{(1-6)}^{N,+}$ and $\gamma_{(1-6)}^{S,+}$ equal to 146.667. These cases have identical average and total re-dispatching costs that are also the worst among the scenarios considered. Parallel to what we observed with a restricted internal market of counter-trading resources (Model 2), TSO^S significantly reduces its re-dispatch costs in Case 3, while TSO^N benefits in Case 4.

In Case 5, we assume that $\gamma_{(1-6)}^{N,+} = 102.667$ and $\gamma_{(1-6)}^{S,+} = 44.000$. These values are respectively the 70% and 30% of 146.667. Under this alternative assumption, system inefficiency increases, in comparison with Cases 1 and 2. Both TSOs face counter-trading costs whose global average is 3.263 €/MWh.

6 Conclusion

In this paper, we discuss the economic and mathematical insights provided by the application of the notion of Generalized Nash Equilibrium and its computation through the Nabetani, Tseng and Fukushima's algorithm for Quasi-Variational Inequality problems applied to a market design problem arising in the restructuring of the European electricity market. Specifically, we study different degrees of coordination in counter-trading activity in the context of the implementation of "Market Coupling" in the European electricity market. We also explain that the approach applies in general to problems of restructuring of an integrated organization into different Business Units.

The reference case for an efficient counter-trading is the overall optimization by a single integrated Transmission System Operator. Full optimization minimizes the cost of removing congestion. Even though efficient, this solution may require too much horizontal integration for being politically acceptable. Alternatives need thus be considered: we consider three organizations that all suppose that the grid remains operated by different TSOs.

The first case is what we call an internal market of counter-trading resources. Following up on current attempts in European circles to get integrated ancillary services like balancing or reserve, we suppose that an operators can resort to any counter-trading resource in the market whether in their jurisdictions or outside. We show that we reproduce the result of the full optimization. This finding also has an interesting mathematical interpretation. It singles out an unusual situation where the solution set of a variational inequality problem (in our case the perfectly coordinated counter-trading problem) coincides with that of the corresponding quasi-variational inequality problem (when all players have an un-discriminatory access at identical price to all market shared resources). The economic interpretation is also useful: the un-discriminatory access to the same set of counter-trading resources “completes the market” and hence makes it efficient. Last but not least the recourse to the NTF algorithm offers a neat explanation of why this happens: even though the organization appears to be of the imperfect coordination type, it may in fact be economically efficient because of the arbitrage taking place in the procurement of counter-trading resources.

Any restriction to the internal market of counter-trading resources degrades the situation. A first degradation happens if operators can only resort in a limited way to counter-trading resources outside of their jurisdiction. The situation can be improved by creating a market of transmission services at the counter-trading level, but full efficiency will only be restored in very particular cases. Here again, the resort to the NTF algorithm makes this analysis particularly easy.

The last case is the one where the market of counter-trading resources is fully segmented. Efficiency is further deteriorated even though the introduction of a common market of transmission resources can again help.

We conduct all the analysis on a simple six nodes region model, but the results are general. Specifically, the recourse to the NTF algorithm only requires solving an optimal power flow problem. This is now a standard model, which shows that the analysis can be conducted for any real world problem.

References

- [1] Arrow, K.J., G. Debreu. 1954. Existence of an equilibrium for a competitive economy. *Econometrica*, **22**, 265-893.
- [2] Chao, H.P., S.C. Peck. 1998. Reliability management in competitive electricity markets. *Journal of Regulatory Economics*, **14**, 198-200.
- [3] Debreu G. 1952. A social equilibrium existence theorem. *Proc. nat. Acad. Sci.* **38**, 886-290.
- [4] Facchinei F., C. Kanzow. 2007. Generalized Nash equilibrium problems. *4OR*, **5**, 173-210.
- [5] Fukushima M. 2008. Restricted generalized Nash equilibria and controlled penalty method. *Computational Management Sciences*, DOI: 10.1007/s10287-009-0097-4.

- [6] Harker P.T. 1991. Generalized Nash games and quasi-variational inequalities. *European Journal of Operation Research*, **54**, 81-94.
- [7] Nabetani K., P. Tseng, M. Fukushima (2009). Parametrized variational inequality approaches to generalized Nash equilibrium problems with shared constraints. *Computational Optimization and Applications*, DOI 10.1007/s10589-009-9256-3.
- [8] Oggioni G., Y. Smeers. 2010a. Degree of coordination in market coupling and counter-trading. *CORE Discussion Paper*, **01**.
- [9] Oggioni G., Y. Smeers. 2010b. Market Coupling and the organization of counter-trading: separating energy and transmission again? *Mimeo*.
- [10] Pang J.S., M. Fukushima. 2005. Quasi-variational inequalities, generalized Nash equilibria, and multi-leader-follower games. *Computational Management Sciences*, **2**, 21–56.
- [11] Ralph D.; Y. Smeers. 2006. EPECs as models for electricity markets. Invited Paper, *Power Systems Conference and Exposition (PSCE)*. DOI: 10.1109/PSCE.2006.296252, 74–80.
- [12] Rosen J.B., 1965. Existence and uniqueness of equilibrium points for concave N-person games. *Econometrica*, **33**, 520-534.
- [13] Smeers Y., J.Y. Wei. 1999. Spatial oligopolistic electricity models with Cournot generators and regulated transmission prices. *Operations Research*, **47**, 102-112.
- [14] Williamson, Oliver E. 1981. The Economics of Organization: The Transaction Cost Approach. *The American Journal of Sociology*, **87(3)**, 548-577.

Appendix A: Market coupling model

When PXs and TSOs are not integrated, PXs clear the energy markets on the basis of a simplified representation of the transmission grid that TSOs give them. This organization of the energy market is known as market-coupling (MC). Market coupling is the most advanced version of cross-border trade implemented in Europe. It is currently applied in France, Belgium and the Netherlands and soon it will be extended to Germany. According to our problem formulation, PXs operate in a coordinated way, but they clear a market organized as depicted in Figure 2. The objective function (101) includes the average re-dispatching costs α . We here suppose that the TSO costs are paid through a levy α charged through the PX. This assumption is introduced for the sake of convenience and does not restrict in any way the scope of the model. We also assume in this example that it is paid by the generators (the reality is that this levy is largely charged to the consumer side, but this distinction is immaterial for our purpose) and then this levy is proportional to the quantity injected in the energy market. Conditions (102) and (103) express the energy balance in Northern

and in the Southern zone respectively. The free variable I indicates the import/export between the two zones. The shadow variables $\phi^{N,S}$ are the marginal energy prices of the Northern and Southern zones respectively. Constraints (104) and (105) impose that flow I respects the transfer limit \bar{I} of the interconnecting line in the two possible directions. The dual variables δ^1 and δ^2 are the marginal costs of utilization of this zonal link. Finally, the non-negativity of variables q_n is required.

$$\mathbf{Min}_{\mathbf{q}_n} \quad \sum_{i=1,2,4} \int_0^{q_i} c_i(\xi) d\xi - \sum_{j=3,5,6} \int_0^{q_j} w_j(\xi) d\xi + \alpha \cdot (q_1 + q_2 + q_4) \quad (101)$$

s.t.

$$q_1 + q_2 - q_3 - I = 0 \quad (\phi^N) \quad (102)$$

$$q_4 - q_5 - q_6 + I = 0 \quad (\phi^S) \quad (103)$$

$$\bar{I} - I \geq 0 \quad (\delta^1) \quad (104)$$

$$\bar{I} + I \geq 0 \quad (\delta^2) \quad (105)$$

$$q_n \geq 0 \quad \forall n \quad (106)$$

Appendix B: Complementarity conditions of the perfectly coordinated counter-trading model

Consider the complementarity formulation of problem (59)-(65), as indicated below, where $\lambda_l = (-\lambda_l^+ + \lambda_l^-)$

$$0 \leq c_i(q_i + \Delta q_i) - \lambda_l \cdot \sum_l PTDF_{i,l} - \mu^1 + \mu^2 \perp (q_i + \Delta q_i) \geq 0 \quad i = 1, 2, 4 \quad (107)$$

$$0 \leq -\omega_j(q_j + \Delta q_j) + \lambda_l \cdot \sum_l PTDF_{j,l} - \mu^1 - \mu^2 \perp (q_j + \Delta q_j) \geq 0 \quad j = 3, 5, 6 \quad (108)$$

$$0 \leq \bar{F}_l - \left[\sum_{i=1,2,4} PTDF_{i,l}(q_i + \Delta q_i) - \sum_{j=3,5,6} PTDF_{j,l}(q_j + \Delta q_j) \right] \perp \lambda_l^+ \geq 0 \quad (109)$$

$$0 \leq \bar{F}_l + \left[\sum_{i=1,2,4} PTDF_{i,l}(q_i + \Delta q_i) - \sum_{j=3,5,6} PTDF_{j,l}(q_j + \Delta q_j) \right] \perp \lambda_l^- \geq 0 \quad (110)$$

$$\sum_i \Delta q_i + \sum_j \Delta q_j = 0 \quad (\mu^1) \quad (111)$$

$$\sum_i \Delta q_i - \sum_j \Delta q_j = 0 \quad (\mu^2) \quad (112)$$

where $c_i(q_i + \Delta q_i) = \frac{\partial \int_{q_i}^{q_i + \Delta q_i} c_i}{\partial \Delta q_i}$ for $i = 1, 2, 4$ and $-\omega_j(q_j + \Delta q_j) = \frac{\partial \int_{q_j}^{q_j + \Delta q_j} w_j}{\partial \Delta q_j}$ for $j = 3, 5, 6$.

Appendix C: TSO^S's problem in the decentralized counter-trading Model 1

The problem (113)-(118) solved by TSO^S is similar to that of the TSO^N. Its formulation is as follows:

$$\mathbf{Min}_{\Delta q_n^S} \quad \sum_{i=1,2,4} \int_{q_i + \Delta q_i^N}^{q_i + \Delta q_i^N + \Delta q_i^S} c_i(\xi) d\xi - \sum_{j=3,5,6} \int_{q_j + \Delta q_j^N}^{q_j + \Delta q_j^N + \Delta q_j^S} w_j(\xi) d\xi \quad (113)$$

s.t.

$$\sum_{i=1,2,4} \Delta q_i^S + \sum_{j=3,5,6} \Delta q_j^S = 0 \quad (\mu^{S,1}) \quad (114)$$

$$\sum_{j=3,5,6} \Delta q_j^S - \sum_{i=1,2,4} \Delta q_i^S = 0 \quad (\mu^{S,2}) \quad (115)$$

$$\bar{F}_l - \left[\sum_{i=1,2,4} PTDF_{i,l}(q_i + \Delta q_i^N + \Delta q_i^S) - \sum_{j=3,5,6} PTDF_{j,l}(q_j + \Delta q_j^N + \Delta q_j^S) \right] \geq 0 \quad (\lambda_l^{S,+}) \quad (116)$$

$$\bar{F}_l + \left[\sum_{i=1,2,4} PTDF_{i,l}(q_i + \Delta q_i^N + \Delta q_i^S) - \sum_{j=3,5,6} PTDF_{j,l}(q_j + \Delta q_j^N + \Delta q_j^S) \right] \geq 0 \quad (\lambda_l^{S,-}) \quad (117)$$

where $l = (1 - 6), (2 - 5)$

$$q_n + \Delta q_n^N + \Delta q_n^S \geq 0 \quad n = 1, \dots, 6 \quad (\nu_n^S) \quad (118)$$

Appendix D: Complementarity conditions of the imperfectly coordinated counter-trading Model 1

We here present the mixed complementarity formulation of the decentralized counter-trading Model 1 (72)-(80). Setting $\gamma_l^N = (-\gamma_l^{N,+} + \gamma_l^{N,-})$; $\gamma_l^S = (-\gamma_l^{S,+} + \gamma_l^{S,-})$ and $\lambda_l = (-\lambda_l^+ + \lambda_l^-)$ for $l = ((1 - 6), (2 - 5))$, the complementarity conditions are as follows:

$$0 \leq c_i(q_i + \Delta q_i^N + \Delta q_i^S) - \sum_l (\lambda_l + \gamma_l^N) \cdot PTDF_{i,l} - \mu^{N,1} + \mu^{N,2} \perp (q_i + \Delta q_i^N + \Delta q_i^S) \geq 0 \quad (119)$$

$$0 \leq -w_j(q_j + \Delta q_j^N + \Delta q_j^S) + \sum_l (\lambda_l + \gamma_l^N) \cdot PTDF_{j,l} - \mu^{N,1} - \mu^{N,2} \perp (q_j + \Delta q_j^N + \Delta q_j^S) \geq 0 \quad (120)$$

$$0 \leq c_i(q_i + \Delta q_i^N + \Delta q_i^S) - \sum_l (\lambda_l + \gamma_l^S) \cdot PTDF_{i,l} - \mu^{S,1} + \mu^{S,2} \perp (q_i + \Delta q_i^N + \Delta q_i^S) \geq 0 \quad (121)$$

$$0 \leq -w_j(q_j + \Delta q_j^N + \Delta q_j^S) + \sum_l (\lambda_l + \gamma_l^S) \cdot PTDF_{j,l} - \mu^{S,1} - \mu^{S,2} \perp (q_j + \Delta q_j^N + \Delta q_j^S) \geq 0 \quad (122)$$

$$0 \leq \bar{F}_l - \left[\sum_{i=1,2,4} PTDF_{i,l}(q_i + \Delta q_i^N + \Delta q_i^S) - \sum_{j=3,5,6} PTDF_{j,l}(q_j + \Delta q_j^N + \Delta q_j^S) \perp \lambda_l^+ \right] \geq 0 \quad (123)$$

$$0 \leq \bar{F}_l + \left[\sum_{i=1,2,4} PTDF_{i,l}(q_i + \Delta q_i^N + \Delta q_i^S) - \sum_{j=3,5,6} PTDF_{j,l}(q_j + \Delta q_j^N + \Delta q_j^S) \perp \lambda_l^- \right] \geq 0 \quad (124)$$

$$\sum_{i=1,2,4} \Delta q_i^N + \sum_{j=3,5,6} \Delta q_j^N = 0 \quad (\mu^{N,1}) \quad (125)$$

$$\sum_{j=3,5,6} \Delta q_j^N - \sum_{i=1,2,4} \Delta q_i^N = 0 \quad (\mu^{N,2}) \quad (126)$$

$$\sum_{i=1,2,4} \Delta q_i^S + \sum_{j=3,5,6} \Delta q_j^S = 0 \quad (\mu^{S,1}) \quad (127)$$

$$\sum_{j=3,5,6} \Delta q_j^S - \sum_{i=1,2,4} \Delta q_i^S = 0 \quad (\mu^{S,2}) \quad (128)$$

where $i = 1, 2, 4$; $j = 3, 5, 6$ and the dual variables $\mu^{N,1}$, $\mu^{S,1}$, $\mu^{N,2}$ and $\mu^{S,2}$ associated with equality constraints are free variables. Moreover, it holds that (see proof of Proposition 2):

$$c_i(q_i + \Delta q_i^N + \Delta q_i^S) = \frac{\partial \int_{q_i}^{q_i + \Delta q_i^N + \Delta q_i^S} c_i}{\partial \Delta q_i^N} = \frac{\partial \int_{q_i}^{q_i + \Delta q_i^N + \Delta q_i^S} c_i}{\partial \Delta q_i^S} \quad i = 1, 2, 4 \quad (129)$$

$$w_j(q_j + \Delta q_j^N + \Delta q_j^S) = \frac{\partial \int_{q_j}^{q_j + \Delta q_j^N + \Delta q_j^S} w_j}{\partial \Delta q_j^N} = \frac{\partial \int_{q_j}^{q_j + \Delta q_j^N + \Delta q_j^S} w_j}{\partial \Delta q_j^S} \quad j = 3, 5, 6 \quad (130)$$

Note that conditions (119), (120), (125) and (126) exclusively refer to TSO^N , while (121), (122), (127) and (128) are those of TSO^S . Finally, (123) and (124) are the common transmission constraints.

Appendix E: Proof of Proposition 1

Because all constraints are linear, constraint qualification holds. Following Theorem 3.3 of [7],

$$\langle g(x^*), \gamma^i \rangle = 0 \quad (131)$$

is a necessary and sufficient condition for a solution x^* to problem $VI(F^\gamma, K)$ to be a *GNE*.

Suppose this property holds for a solution of the parametrized problem (72)-(80). It is then a *GNE* and we can write the KKT conditions of that parametrized problem (see the complementarity conditions in Appendix D). Suppose that $q_n + \Delta q_n^N + \Delta q_n^S > 0$ for all n and that $\lambda_l = (-\lambda_l^+ + \lambda_l^-)$

in order to simplify the discussion. Then the optimality condition in (119)-(122) are binding and it follows that:

$$c_i(q_i + \Delta q_i^N + \Delta q_i^S) - \sum_l \gamma_l^N PTDF_{i,l} - \sum_l \lambda_l \cdot PTDF_{i,l} - \mu^{N,1} + \mu^{N,2} = 0 \quad (132)$$

$$-w_j(q_j + \Delta q_j^N + \Delta q_j^S) + \sum_l \gamma_l^N PTDF_{j,l} + \sum_l \lambda_l \cdot PTDF_{j,l} - \mu^{N,1} - \mu^{N,2} = 0 \quad (133)$$

$$c_i(q_i + \Delta q_i^N + \Delta q_i^S) - \sum_l \gamma_l^S PTDF_{i,l} - \sum_l \lambda_l \cdot PTDF_{i,l} - \mu^{S,1} + \mu^{S,2} = 0 \quad (134)$$

$$-w_j(q_j + \Delta q_j^N + \Delta q_j^S) + \sum_l \gamma_l^S PTDF_{j,l} + \sum_l \lambda_l \cdot PTDF_{j,l} - \mu^{S,1} - \mu^{S,2} = 0 \quad (135)$$

Subtracting (134) from (132) and (135) from (133) leads to the following conditions:

$$\sum_l (\gamma_l^N - \gamma_l^S) PTDF_{i,l} = -(\mu^{N,1} - \mu^{N,2}) + (\mu^{S,1} - \mu^{S,2}) \quad i = 1, 2, 4 \quad (136)$$

$$\sum_l (\gamma_l^N - \gamma_l^S) PTDF_{j,l} = (\mu^{N,1} + \mu^{N,2}) - (\mu^{S,1} + \mu^{S,2}) \quad j = 3, 5, 6 \quad (137)$$

Because node 6 is the hub, we have $PTDF_{6,l} = 0$ and hence $(\mu^{N,1} + \mu^{N,2}) - (\mu^{S,1} + \mu^{S,2}) = 0$ in (137). This in turn implies $(\gamma_{(1-6)}^N - \gamma_{(1-6)}^S) PTDF_{j,(1-6)} + (\gamma_{(2-5)}^N - \gamma_{(2-5)}^S) PTDF_{j,(2-5)} = 0$ for $j = 3, 5$ and then:

$$(\gamma_{(1-6)}^N - \gamma_{(1-6)}^S) = -\frac{PTDF_{j,(2-5)}}{PTDF_{j,(1-6)}} (\gamma_{(2-5)}^N - \gamma_{(2-5)}^S) \quad j = 3, 5 \quad (138)$$

This is verified only when $\gamma_l^N = \gamma_l^S$ because the ratio $\frac{PTDF_{j,(2-5)}}{PTDF_{j,(1-6)}}$ assumes a positive and a negative value. Taking stock of condition (131), we can deduce that:

$$\gamma_l^{N,+} = \gamma_l^{S,+}$$

$$\gamma_l^{N,-} = \gamma_l^{S,-}$$

■

Appendix F: Proof of Proposition 2

Assume again in order to simplify the discussion that $q_n + \Delta q_n^N + \Delta q_n^S > 0 \forall n$ and define $\lambda_l^N = (-\lambda_l^{N,+} + \lambda_l^{N,-})$ and $\lambda_l^S = (-\lambda_l^{S,+} + \lambda_l^{S,-})$ for $l = ((1-6), (2-5))$. We state the KKT conditions of the problems of the two TSOs' problems (namely (66)-(71) for TSO^N and (113)-(118) for TSO^S) by deriving with respect to the variables Δq_n^N and Δq_n^S . We get:

$$\frac{\partial \int_{q_i}^{q_i + \Delta q_i^N + \Delta q_i^S} c_i}{\partial \Delta q_i^Z} - \sum_l \lambda_l^Z PTDF_{i,l} - \mu^{Z,1} + \mu^{Z,2} = 0 \quad i = 1, 2, 4 \quad Z = N, S \quad (139)$$

$$-\frac{\partial \int_{q_j}^{q_j + \Delta q_j^N + \Delta q_j^S} w_j}{\partial \Delta q_j^Z} + \sum_l \lambda_l^Z PTDF_{j,l} - \mu^{Z,1} - \mu^{Z,2} = 0 \quad j = 3, 5, 6 \quad Z = N, S \quad (140)$$

From (139) and (140), we can immediately deduce that:

$$\frac{\partial \int_{q_i}^{q_i + \Delta q_i^N + \Delta q_i^S} c_i}{\partial \Delta q_i^N} = \frac{\partial \int_{q_i}^{q_i + \Delta q_i^N + \Delta q_i^S} c_i}{\partial \Delta q_i^S} = c_i(q_i + \Delta q_i^N + \Delta q_i^S) \quad i = 1, 2, 4 \quad (141)$$

$$\frac{\partial \int_{q_j}^{q_j + \Delta q_j^N + \Delta q_j^S} w_j}{\partial \Delta q_j^N} = \frac{\partial \int_{q_j}^{q_j + \Delta q_j^N + \Delta q_j^S} w_j}{\partial \Delta q_j^S} = -w_j(q_j + \Delta q_j^N + \Delta q_j^S) \quad j = 3, 5, 6 \quad (142)$$

and summing (139) to (140), we have:

$$c_i(q_i + \Delta q_i^N + \Delta q_i^S) - w_j(q_j + \Delta q_j^N + \Delta q_j^S) + \sum_l \lambda_l^Z (PTDF_{j,l} - PTDF_{i,l}) - 2\mu^{Z,1} = 0 \quad Z = N, S \quad (143)$$

Since condition (143) holds for both TSOs, we can rewrite it in an explicit way:

$$c_i(q_i + \Delta q_i^N + \Delta q_i^S) - w_j(q_j + \Delta q_j^N + \Delta q_j^S) + \sum_l \lambda_l^N (PTDF_{j,l} - PTDF_{i,l}) - 2\mu^{N,1} = 0 \quad (144)$$

$$c_i(q_i + \Delta q_i^N + \Delta q_i^S) - w_j(q_j + \Delta q_j^N + \Delta q_j^S) + \sum_l \lambda_l^S (PTDF_{j,l} - PTDF_{i,l}) - 2\mu^{S,1} = 0 \quad (145)$$

Taking into account the results of conditions (141) and (142) and subtracting (145) from (144), we get:

$$\sum_l (\lambda_l^N - \lambda_l^S) (PTDF_{j,l} - PTDF_{i,l}) - 2(\mu^{N,1} - \mu^{S,1}) = 0 \quad (146)$$

We now subtract (140) from (139) and apply the above reasoning. We get:

$$c_i(q_i + \Delta q_i^N + \Delta q_i^S) + w_j(q_j + \Delta q_j^N + \Delta q_j^S) - \sum_l \lambda_l^Z (PTDF_{j,l} + PTDF_{i,l}) + 2\mu^{Z,2} = 0 \quad Z = N, S \quad (147)$$

that can be substituted by these two conditions:

$$c_i(q_i + \Delta q_i^N + \Delta q_i^S) + w_j(q_j + \Delta q_j^N + \Delta q_j^S) - \sum_l \lambda_l^N (PTDF_{j,l} + PTDF_{i,l}) + 2\mu^{N,2} = 0 \quad (148)$$

$$c_i(q_i + \Delta q_i^N + \Delta q_i^S) + w_j(q_j + \Delta q_j^N + \Delta q_j^S) - \sum_l \lambda_l^S (PTDF_{j,l} + PTDF_{i,l}) + 2\mu^{S,2} = 0 \quad (149)$$

Again, taking stock of conditions (141) and (142), (148) and (149) become:

$$\sum_l (\lambda_l^N - \lambda_l^S) (PTDF_{j,l} + PTDF_{i,l}) - 2(\mu^{N,2} - \mu^{S,2}) = 0 \quad (150)$$

The combination of conditions (146) and (150) leads to the following equalities:

$$\sum_l (\lambda_l^N - \lambda_l^S) PTDF_{j,l} - (\mu^{N,1} - \mu^{S,1}) - (\mu^{N,2} - \mu^{S,2}) = 0 \quad (151)$$

$$\sum_l (\lambda_l^N - \lambda_l^S) PTDF_{i,l} + (\mu^{N,1} - \mu^{S,1}) - (\mu^{N,2} - \mu^{S,2}) = 0 \quad (152)$$

By setting, $\alpha = (\mu^{N,1} + \mu^{N,2}) - (\mu^{S,1} + \mu^{S,2})$ and $\beta = (\mu^{N,1} - \mu^{N,2}) - (\mu^{S,1} - \mu^{S,2})$ conditions (151) and (152) become:

$$\sum_l (\lambda_l^N - \lambda_l^S) PTDF_{j,l} - \alpha = 0 \quad j = 3, 5, 6 \quad (153)$$

$$\sum_l (\lambda_l^N - \lambda_l^S) PTDF_{i,l} + \beta = 0 \quad i = 1, 2, 4 \quad (154)$$

We observe that $PTDF_{6,l} = 0$. This implies that $\alpha = 0$. If $\alpha = 0$, then it holds that:

$$\sum_l (\lambda_l^N - \lambda_l^S) PTDF_{j,l} = 0 \quad j = 3, 5 \quad (155)$$

This corresponds to:

$$(\lambda_{(1-6)}^N - \lambda_{(1-6)}^S) PTDF_{j,(1-6)} + (\lambda_{(2-5)}^N - \lambda_{(2-5)}^S) PTDF_{j,(2-5)} = 0 \quad j = 3, 5 \quad (156)$$

$$(\lambda_{(1-6)}^N - \lambda_{(1-6)}^S) = -\frac{PTDF_{j,(2-5)}}{PTDF_{j,(1-6)}} (\lambda_{(2-5)}^N - \lambda_{(2-5)}^S) \quad j = 3, 5 \quad (157)$$

But $\frac{PTDF_{j,(2-5)}}{PTDF_{j,(1-6)}}$ assumes a positive and a negative value respectively for $j = 3, 5$ and then $\lambda_l^N = \lambda_l^S$. This result means that the marginal value of congestion of one line is identical for both TSOs. Consequently, the two TSOs are implicitly coordinated and there is no arbitrage. This also implies that $\alpha = \beta = 0$ and then:

$$(\mu^{N,1} + \mu^{N,2}) - (\mu^{S,1} + \mu^{S,2}) = 0 \quad (158)$$

$$(\mu^{N,1} - \mu^{N,2}) - (\mu^{S,1} - \mu^{S,2}) = 0 \quad (159)$$

These can be rewritten as follows:

$$\mu^{N,1} - \mu^{S,1} = (\mu^{S,2} - \mu^{N,2}) \quad (160)$$

$$\mu^{N,1} - \mu^{S,1} = -(\mu^{S,2} - \mu^{N,2}) = 0 \quad (161)$$

This implies that $\mu^{N,1} = \mu^{S,1}$ and $\mu^{N,2} = \mu^{S,2}$. ■

Appendix G: Proof of Corollary 1

Corollary 3.2 of Nabetani, Tseng and Fukushima's paper (see [7]) proves that if the dual problem has solution then

$$\bigcup_{\gamma \in \Gamma} SOL^{VI(F^\gamma, K)} \supseteq SOL^{GNEP}$$

We first consider the case where $\gamma = 0$. Under this assumption $VI(F, K) = VI(F^{\gamma=0}, K)$ and the parametrized problem is identical to the optimized counter-trading problem. This can be easily done by imposing $\Delta q_n^N + \Delta q_n^S = \Delta q_n$.

As already observed, the optimized counter-trading problem has a unique solution because of the convexity of the set K and the strict convexity of its objective function. This implies that the solution of the decentralized counter-trading problem (72)-(80) coincides with that of the optimized counter-trading model (59)-(65) when $\gamma = 0$.

We now show that the solution set of problem $VI(F^\gamma, K)$ when $\gamma_l^{N,\pm} = \gamma_l^{S,\pm}$ and $\mu^{Z,1} = \mu^{Z,2}$ reduces to a unique solution that is the solution of the optimized counter-trading problem (59)-(65).

Compare now the KKT conditions of the optimized counter-trading problem with those of the decentralized counter-trading problem. Denote $\Delta q_n = \Delta q_n^N + \Delta q_n^S$ for all n and $\lambda_l = (-\lambda_l^+ + \lambda_l^-)$, the optimality conditions of the optimized counter-trading model are as follows (compare complementarity conditions in Appendix B):

$$c_i(q_i + \Delta q_i^N + \Delta q_i^S) - \sum_l \lambda_l PTDF_{i,l} - \mu^1 + \mu^2 = 0 \quad i = 1, 2, 4 \quad (162)$$

$$-w_j(q_j + \Delta q_j^N + \Delta q_j^S) + \sum_l \lambda_l PTDF_{j,l} - \mu^1 - \mu^2 = 0 \quad j = 3, 5, 6 \quad (163)$$

+ transmission constraints and the re-dispatching balances.

Denoting similarly $\gamma_l^N = (-\gamma_l^{N,+} + \gamma_l^{N,-})$, $\gamma_l^S = (-\gamma_l^{S,+} + \gamma_l^{S,-})$ and knowing that $\gamma_l^{N,\pm} = \gamma_l^{S,\pm}$, the optimality conditions of the decentralized counter-trading Model 1 are as follows:

$$c_i(q_i + \Delta q_i^N + \Delta q_i^S) - \sum_l (\lambda_l + \gamma_l^N) PTDF_{i,l} - \mu^1 + \mu^2 = 0 \quad i = 1, 2, 4 \quad (164)$$

$$-w_j(q_j + \Delta q_j^N + \Delta q_j^S) + \sum_l (\lambda_l + \gamma_l^N) PTDF_{j,l} - \mu^1 - \mu^2 = 0 \quad j = 3, 5, 6 \quad (165)$$

+ transmission constraints and the re-dispatching balances.

Setting $\lambda_l = \lambda_l + \gamma_l^N$ one can easily see that the two groups of optimality conditions are identical and then the corresponding problems admit the same solution set.

Appendix H: Complementarity conditions of the decentralized counter-trading Model 2

We here show the mixed complementarity formulation of the un-coordinated counter-trading Model 2 (81)-(87). Setting $\gamma_l^N = (-\gamma_l^{N,+} + \gamma_l^{N,-})$; $\gamma_l^S = (-\gamma_l^{S,+} + \gamma_l^{S,-})$ and $\lambda_l = (-\lambda_l^+ + \lambda_l^-)$ for $l = ((1-6), (2-5))$ and introducing $\eta_n^N = \eta_n^{N,+} - \eta_n^{N,-}$ for $n = 4, 5, 6$ and $\eta_n^S = \eta_n^{S,+} - \eta_n^{S,-}$ for $n = 1, 2, 3$ where $\eta_i^{N,+}$, $\eta_i^{N,-}$, $\eta_i^{S,+}$ and $\eta_i^{S,-}$ are respectively the dual variables of $\Delta q_i^N - \Delta q_i^S \geq 0$; $\Delta q_i^N + \Delta q_i^S \geq 0$; $\Delta q_i^S - \Delta q_i^N \geq 0$; $\Delta q_i^S + \Delta q_i^N \geq 0$, the complementarity conditions become as follows.:

$$0 \leq c_i(q_i + \Delta q_i^N + \Delta q_i^S) - \sum_l (\lambda_l + \gamma_l^N) \cdot PTDF_{i,l} - \mu^{N,1} + \mu^{N,2} \perp (q_i + \Delta q_i^N + \Delta q_i^S) \geq 0 \quad i = 1, 2 \quad (166)$$

$$0 \leq c_4(q_4 + \Delta q_4^N + \Delta q_4^S) - \sum_l (\lambda_l + \gamma_l^N) \cdot PTDF_{4,l} - \mu^{N,1} + \mu^{N,2} + \eta_4^N \perp (q_4 + \Delta q_4^N + \Delta q_4^S) \geq 0 \quad (167)$$

$$0 \leq -w_3(q_3 + \Delta q_3^N + \Delta q_3^S) + \sum_l (\lambda_l + \gamma_l^N) \cdot PTDF_{3,l} - \mu^{N,1} - \mu^{N,2} \perp (q_3 + \Delta q_3^N + \Delta q_3^S) \geq 0 \quad (168)$$

$$0 \leq -w_j(q_j + \Delta q_j^N + \Delta q_j^S) + \sum_l (\lambda_l + \gamma_l^N) \cdot PTDF_{j,l} - \mu^{N,1} - \mu^{N,2} + \eta_j^N \perp (q_j + \Delta q_j^N + \Delta q_j^S) \geq 0 \quad j = 5, 6 \quad (169)$$

$$0 \leq c_i(q_i + \Delta q_i^N + \Delta q_i^S) - \sum_l (\lambda_l + \gamma_l^S) \cdot PTDF_{i,l} - \mu^{S,1} + \mu^{S,2} + \eta_i^S \perp (q_i + \Delta q_i^N + \Delta q_i^S) \geq 0 \quad i = 1, 2 \quad (170)$$

$$0 \leq c_4(q_4 + \Delta q_4^N + \Delta q_4^S) - \sum_l (\lambda_l + \gamma_l^S) \cdot PTDF_{4,l} - \mu^{S,1} + \mu^{S,2} \perp (q_4 + \Delta q_4^N + \Delta q_4^S) \geq 0 \quad (171)$$

$$0 \leq -w_3(q_3 + \Delta q_3^N + \Delta q_3^S) + \sum_l (\lambda_l + \gamma_l^S) \cdot PTDF_{3,l} - \mu^{S,1} - \mu^{S,2} + \eta_3^S \perp (q_3 + \Delta q_3^N + \Delta q_3^S) \geq 0 \quad (172)$$

$$0 \leq -w_j(q_j + \Delta q_j^N + \Delta q_j^S) + \sum_l (\lambda_l + \gamma_l^S) \cdot PTDF_{j,l} - \mu^{S,1} - \mu^{S,2} \perp (q_j + \Delta q_j^N + \Delta q_j^S) \geq 0 \quad j = 5, 6 \quad (173)$$

$$0 \leq \bar{F}_l - \left[\sum_{i=1,2,4} PTDF_{i,l}(q_i + \Delta q_i^N + \Delta q_i^S) - \sum_{j=3,5,6} PTDF_{j,l}(q_j + \Delta q_j^N + \Delta q_j^S) \right] \perp \lambda_l^+ \geq 0 \quad (174)$$

$$0 \leq \bar{F}_l + \left[\sum_{i=1,2,4} PTDF_{i,l}(q_i + \Delta q_i^N + \Delta q_i^S) - \sum_{j=3,5,6} PTDF_{j,l}(q_j + \Delta q_j^N + \Delta q_j^S) \right] \perp \lambda_l^- \geq 0 \quad (175)$$

$$0 \leq \overline{\Delta q_n^N} - \Delta q_n^N \perp \eta_n^{N,+} \geq 0 \quad n = 4, 5, 6 \quad (176)$$

$$0 \leq \overline{\Delta q_n^N} + \Delta q_n^N \perp \eta_n^{N,-} \geq 0 \quad n = 4, 5, 6 \quad (177)$$

$$0 \leq \overline{\Delta q_n^S} - \Delta q_n^S \perp \eta_n^{S,+} \geq 0 \quad n = 1, 2, 3 \quad (178)$$

$$0 \leq \overline{\Delta q_n^S} + \Delta q_n^S \perp \eta_n^{S,-} \geq 0 \quad n = 1, 2, 3 \quad (179)$$

$$\sum_{i=1,2,4} \Delta q_i^N + \sum_{j=3,5,6} \Delta q_j^N = 0 \quad (\mu^{N,1}) \quad (180)$$

$$\sum_{j=3,5,6} \Delta q_j^N - \sum_{i=1,2,4} \Delta q_i^N = 0 \quad (\mu^{N,2}) \quad (181)$$

$$\sum_{i=1,2,4} \Delta q_i^S + \sum_{j=3,5,6} \Delta q_j^S = 0 \quad (\mu^{S,1}) \quad (182)$$

$$\sum_{j=3,5,6} \Delta q_j^S - \sum_{i=1,2,4} \Delta q_i^S = 0 \quad (\mu^{S,2}) \quad (183)$$

Appendix I: Proof of Proposition 5

Let us denote the NTF's formulation of problem (81)-(91) as to $VI(F^\gamma, K_2)$. The primal solution of problem $VI(F^{\gamma=0}, K_2)$ is unique when all $\gamma_i^{N/S} = 0$. This is because both the objective function (81) and the set defined by the constraints are convex. Due to the lack of perfect arbitrage between the two TSOs, the equality $\gamma_i^N = \gamma_i^S$ is no more ensured and then when $\gamma_i^{N/S} \neq 0$ we have two different cases.

If $\gamma_i^{N/S} \neq 0$ and $\gamma_i^N = \gamma_i^S$, then the transformations applied to λ_l in the complementarity version of problem (81)-(87) are simply translations (as we already seen in the Proof of Corollary 1 in Appendix G). This means that:

$$\lambda_l^{N/S} = \lambda_l + \gamma_l^{N/S}$$

and implies that under this assumption the solution set of problem $VI(F^\gamma, K_2)$ coincides with that of problem $VI(F^{\gamma=0}, K_2)$. Since the solution set of the primal problem of $VI(F^{\gamma=0}, K_2)$ contains one solution, this is also the unique solution of $VI(F^{\gamma=0}, K_2)$.

This does not happens when $\gamma_i^{N/S} \neq 0$ and $\gamma_i^N \neq \gamma_i^S$ because the translations operated on the problems of are now different. In other words:

$$\lambda_l^N = \lambda_l + \gamma_l^N \quad (184)$$

$$\lambda_l^S = \lambda_l + \gamma_l^S \quad (185)$$

respectively for the TSO^N and TSO^S. As a consequence, the solution set can admit several solutions. However, from conditions (184) and (185), one immediately deduces that $\lambda_l^N = \lambda_l = \lambda_l^S$ when $\gamma_l^{N/S} = 0$ and that

$$\lambda_l^N - \lambda_l^S = \gamma_l^N - \gamma_l^S$$

■

Appendix J: Complementarity conditions of the decentralized counter-trading Model 3

This section presents the complementarity formulation of the imperfectly coordinated counter-trading Model 3. By setting $\gamma_l^N = (-\gamma_l^{N,+} + \gamma_l^{N,-})$; $\gamma_l^S = (-\gamma_l^{S,+} + \gamma_l^{S,-})$ and $\lambda_l = (-\lambda_l^+ + \lambda_l^-)$ for $l = ((1 - 6), (2 - 5))$, we get the following conditions:

$$0 \leq c_i(q_i + \Delta q_i^N) - \sum_l (\lambda_l + \gamma_l^N) \cdot PTDF_{i,l} - \mu^{N,1} + \mu^{N,2} \perp (q_i + \Delta q_i^N) \geq 0 \quad i = 1, 2 \quad (186)$$

$$0 \leq -w_3(q_3 + \Delta q_3^N) + \sum_l (\lambda_l + \gamma_l^N) \cdot PTDF_{3,l} - \mu^{N,1} - \mu^{N,2} \perp (q_3 + \Delta q_3^N) \geq 0 \quad (187)$$

$$0 \leq c_4(q_4 + \Delta q_4^S) - \sum_l (\lambda_l + \gamma_l^S) \cdot PTDF_{4,l} - \mu^{S,1} + \mu^{S,2} \perp (q_4 + \Delta q_4^S) \geq 0 \quad (188)$$

$$0 \leq -w_j(q_j + \Delta q_j^S) + \sum_l (\lambda_l + \gamma_l^S) \cdot PTDF_{j,l} - \mu^{S,1} - \mu^{S,2} \perp (q_j + \Delta q_j^S) \geq 0 \quad j = 5, 6 \quad (189)$$

$$0 \leq \bar{F}_l - \left[\sum_{i=1,2} PTDF_{i,l}(q_i + \Delta q_i^N) + PTDF_{4,l}(q_4 + \Delta q_4^S) - PTDF_{3,l}(q_3 + \Delta q_3^N) \right. \quad (190)$$

$$\left. - \sum_{j=5,6} PTDF_{j,l}(q_j + \Delta q_j^S) \right] \perp \lambda_l^+ \geq 0$$

$$0 \leq \bar{F}_l + \left[\sum_{i=1,2} PTDF_{i,l}(q_i + \Delta q_i^N) + PTDF_{4,l}(q_4 + \Delta q_4^S) - PTDF_{3,l}(q_3 + \Delta q_3^N) \right. \quad (191)$$

$$\left. - \sum_{j=5,6} PTDF_{j,l}(q_j + \Delta q_j^S) \right] \perp \lambda_l^- \geq 0$$

$$\Delta q_3^N + \Delta q_1^N + \Delta q_2^N = 0 \quad (\mu^{N,1}) \quad (192)$$

$$\Delta q_3^N - \Delta q_1^N - \Delta q_2^N = 0 \quad (\mu^{N,2}) \quad (193)$$

$$\Delta q_5^S + \Delta q_6^S + \Delta q_4^S = 0 \quad (\mu^{S,1}) \quad (194)$$

$$\Delta q_5^S + \Delta q_6^S - \Delta q_4^S = 0 \quad (\mu^{S,2}) \quad (195)$$

Appendix K: Proof of Proposition 7

The proof is parallel to that of Proposition 5 (see Appendix I).