

## **What's in a Name? Intelligent Classification and Identification of Online Media Content**

Dementiev, Eugene

The copyright of this thesis rests with the author and no quotation from it or information derived from it may be published without the prior written consent of the author

For additional information about this publication click this link.

<http://qmro.qmul.ac.uk/xmlui/handle/123456789/12676>

Information about this research object was correct at the time of download; we occasionally make corrections to records, please therefore check the published record when citing. For more information contact [scholarlycommunications@qmul.ac.uk](mailto:scholarlycommunications@qmul.ac.uk)

Queen Mary University of London

**What's in a Name? Intelligent  
Classification and Identification  
of Online Media Content**

Eugene Dementiev

2016

Submitted in partial fulfilment of the requirements of the Degree of Doctor of Philosophy

# Declarations

I, Dementiev Eugene, confirm that the research included within this thesis is my own work or that where it has been carried out in collaboration with, or supported by others, that this is duly acknowledged below and my contribution indicated.

I attest that I have exercised reasonable care to ensure that the work is original, and does not to the best of my knowledge break any UK law, infringe any third party's copyright or other Intellectual Property Right, or contain any confidential material.

I accept that the College has the right to use plagiarism detection software to check the electronic version of the thesis.

I confirm that this thesis has not been previously submitted for the award of a degree by this or any other university.

The copyright of this thesis rests with the author and no quotation from it or information derived from it may be published without the prior written consent of the author.

Eugene Dementiev

Submission date: 04.04.2016

Last updated: 24.05.2016

# Acknowledgements

I would like to thank my supervisor Professor Norman Fenton for his support, guidance and understanding; and for giving me the opportunity to learn so many things from him. I could never wish for a better supervisor.

Prof Martin Neil, Dr William Marsh, Tanmoy Kumar, Evangelia Kyrimi, and other research group colleagues provided invaluable insight, comments and ideas, for which I am deeply grateful.

The feedback provided by my examiners Andrew Moore and Jeroen Keppens was extremely helpful and aided me in improving the final edition of this thesis.

A separate gratitude is to MovieLabs for supplying data for the research and useful knowledge, and to Agena for graciously providing their BN modelling software and calculation API.

I also extend my thanks to the EPSRC for funding and to Queen Mary University of London for making this project possible. This work was also supported in part by European Research Council Advanced Grant ERC-2013-AdG339182-BAYES\_KNOWLEDGE (April 2015-Dec 2015).

A special gratitude to my wife Aliya who gave her best to help me through the final stages of this project, and to my family who were very supportive throughout the project.

# Abstract

The sheer amount of content on the Internet poses a number of challenges for content providers and users alike. The providers want to classify and identify user downloads for market research, advertising and legal purposes. From the user's perspective it is increasingly difficult to find interesting content online, hence content personalisation and media recommendation is expected by the public. An especially important (and also technically challenging) case is when a downloadable item has no supporting description or meta-data, as in the case of (normally illegal) torrent downloads, which comprise 10 to 30 percent of the global traffic depending on the region. In this case, apart from its size, we have to rely entirely on the filename – which is often deliberately obfuscated – to identify or classify what the file really is.

The Hollywood movie industry is sufficiently motivated by this problem that it has invested significant research – through its company MovieLabs – to help understand more precisely what material is being illegally downloaded in order both to combat piracy and exploit the extraordinary opportunities for future sales and marketing. This thesis was inspired, and partly supported, by MovieLabs who recognised the limitations of their current purely data-driven algorithmic approach.

The research hypothesis is that, by extending state-of-the-art information retrieval (IR) algorithms and by developing an underlying causal Bayesian Network (BN) incorporating expert judgment and data, it is possible to improve on the accuracy of MovieLabs's benchmark algorithm for identifying and classifying torrent names. In addition to identification and standard classification (such as whether the file is Movie, Soundtrack, Book, etc.) we consider the crucial orthogonal classifications of pornography and malware. The work in the thesis provides a number of novel extensions to the generic problem of classifying and personalising

internet content based on minimal data and on validating the results in the absence of a genuine 'oracle'.

The system developed in the thesis (called *Toran*) is extensively validated using a sample of torrents classified by a panel of 3 human experts and the MovieLabs system, divided into knowledge and validation sets of 2,500 and 479 records respectively. In the absence of an automated classification oracle, we established manually the true classification for the test set of 121 records in order to be able to compare Toran, the human panel (HP) and the MovieLabs system (MVL). The results show that Toran performs better than MVL for the key medium categories that contain most items, such as music, software, movies, TVs and other videos. Toran also has the ability to assess the risk of fakes and malware prior to download, and is on par or even surpasses human experts in this capability.

# Table of Contents

<b>Declarations .....</b>	<b>2</b>
<b>Acknowledgements .....</b>	<b>3</b>
<b>Abstract .....</b>	<b>4</b>
<b>List of Abbreviations.....</b>	<b>12</b>
<b>Glossary .....</b>	<b>15</b>
<b>Notation .....</b>	<b>16</b>
<b>List of Figures .....</b>	<b>17</b>
<b>List of Tables.....</b>	<b>20</b>
<b>List of Algorithms .....</b>	<b>24</b>
<b>Chapter 1 Introduction .....</b>	<b>25</b>
1.1. Motivation.....	25
1.2. Research Hypothesis and Objectives .....	33
1.3. Structure of the Thesis.....	34
<b>Chapter 2 Background and Data.....</b>	<b>36</b>
2.1. The Benchmark and Prototype Systems .....	36
2.2. File Data.....	39
2.3. Class Taxonomy .....	41
2.4. Title and Names Databases .....	43
2.5. Data Samples .....	46
2.6. Classification and Evaluation Methods .....	57
2.6.1. Brief Introduction to Document Classification.....	59

2.6.2.	Naïve Bayesian Classifiers .....	61
2.6.3.	Terms of Accuracy .....	63
2.6.4.	Probabilistic Prediction Metrics .....	66
2.6.5.	Applying Accuracy Metrics in the Project .....	71
2.7.	String Comparison .....	75
2.8.	Summary .....	80
<b>Chapter 3</b>	<b>Torrent Name Bayesian Network Model .....</b>	<b>81</b>
3.1.	Bayes' Theorem .....	82
3.2.	Bayesian Networks Overview and Key Concepts .....	84
3.2.1.	Bayesian Network Definition .....	84
3.2.2.	Simple BN Examples .....	85
3.2.3.	Bayesian Network Inference Algorithms, Tools and Applications .....	89
3.2.4.	Hard, Soft and Virtual Evidence .....	92
3.2.5.	Modelling Continuous Variables .....	93
3.3.	Building Bayesian Networks .....	94
3.3.1.	Knowledge Engineering versus Machine Learning .....	95
3.3.2.	Conditional Dependency .....	97
3.3.3.	Defining BN Structure .....	100
3.3.4.	Prior and Likelihood Definition .....	102
3.3.5.	Applying Idioms in the Project .....	105
3.4.	Model Overview .....	113
3.5.	Real Medium .....	114
3.6.	Fakes and Malware .....	116



3.7.	Advertised Medium .....	120
3.8.	File Size .....	124
3.9.	Signatures.....	126
3.9.1.	Regular Signature Node NPTs.....	128
3.9.2.	Special Signature Node NPTs .....	135
3.10.	Porn Detection .....	137
3.11.	Title Detection.....	141
3.12.	Risky Titles.....	144
3.13.	Extensibility .....	147
3.14.	Summary .....	149
<b>Chapter 4</b>	<b>Capturing Evidence .....</b>	<b>150</b>
4.1.	Signature Definition.....	151
4.1.1.	Pattern Types .....	154
4.1.2.	Associations and Strength .....	157
4.1.3.	Special Signatures .....	162
4.2.	Porn Studios and Actors .....	164
4.3.	Signature Detection and Filtering Algorithm .....	165
4.4.	Title Matching.....	170
4.4.1.	Title Alignment .....	171
4.4.2.	n-gram Pre-filtering .....	175
4.4.3.	Procedure .....	179
4.5.	Extensibility .....	185
4.6.	Summary .....	186

<b>Chapter 5</b>	<b>Formal Framework for System Evaluation</b>	<b>187</b>
5.1.	Compatibility of Agent Output	188
5.2.	Verdict Mapping and Probability Vector Translation	190
5.3.	Comparing MVL and Toran on DS2500 and DS480	193
5.4.	Scoring Metric Requirements	194
5.5.	Tiered Scoring Rule	195
5.6.	Random Predictions	199
5.7.	Summary	201
<b>Chapter 6</b>	<b>Empirical Evaluation and Analysis</b>	<b>202</b>
6.1.	Assessment of Probabilistic Predictions	204
6.1.1.	Knowledge and Validation Sets	204
6.1.2.	DS120: Test Set	206
6.2.	Confusing Predictions	207
6.3.	Evaluation in Terms of Accuracy	211
6.3.1.	Accuracy Metrics	212
6.3.2.	Receiver Operating Characteristic (ROC)	213
6.4.	BitSnoop Experiment	216
6.5.	Porn Detection	219
6.6.	Fakes and Malware	220
6.7.	Summary	221
<b>Chapter 7</b>	<b>Summary and Conclusions</b>	<b>223</b>
7.1.	Methodology	224
7.2.	Research Objectives	226

7.3.	Future Work.....	228
7.3.1.	Improving Toran.....	228
7.3.2.	Further Contribution to Validation .....	230
7.4.	Conclusions.....	231
	<b>Appendices.....</b>	<b>234</b>
	<b>Appendix A XML Data Structure.....</b>	<b>234</b>
	<b>Appendix B Results in XML Format .....</b>	<b>237</b>
	<b>Appendix C Databases of Titles, Actors and Studios .....</b>	<b>237</b>
C.1.	Titles Database.....	237
C.2.	Porn Actor Database .....	237
C.3.	Porn Studio Database .....	237
	<b>Appendix D Data Sets .....</b>	<b>238</b>
D.1.	DS2500.....	238
D.2.	DS480.....	238
D.3.	DS120.....	238
D.4.	Fakes and Malware Data Set .....	238
D.5.	BitSnoop Data Set.....	238
	<b>Appendix E Junction Tree BN Propagation Algorithm .....</b>	<b>239</b>
	<b>Appendix F BN Definition .....</b>	<b>243</b>
	<b>Appendix G Example Model Output for Different Signature Combinations .....</b>	<b>247</b>
	<b>Appendix H Signature and Keyword Configurations .....</b>	<b>249</b>
H.1.	MovieLabs Keyword Configuration .....	249
H.2.	Toran Signature Configuration .....	249

<b>Appendix I</b>	<b>Pattern Parts of the TV Signature .....</b>	<b>250</b>
<b>Appendix J</b>	<b>Torrent Name Filtering Examples.....</b>	<b>251</b>
<b>References.....</b>		<b>252</b>

# List of Abbreviations

AE	Absolute error
API	Application Program Interface
AS	Absolute Error
AST	Absolute Error Tiered
BLAST	Basic Local Alignment Search Tool
BLOSUM	Blocks Substitution Matrix
BN	Bayesian Network
BS	Brier Score
BST	Brier Score Tiered
CB	Content-Based
CF	Collaborative Filtering
CSV	Categorisation Status Value
DAG	Directed Acyclic Graph
DS120	Data Set 120
DS2500	Data Set 2500
DS480	Data Set 480
DSBS	BitSnoop Data Set
DSFM	Fakes and Malware Data Set
FN	False Negatives
FP	False Positives
FPR	False Positive Rate
GB	Gigabyte

HP	Human Panel
IDF	Inverse Document Frequency
IFPI	International Federation of the Phonographic Industry
IMDb	Internet Movie Database
IMDbPY	IMDb Python
IR	Information Retrieval
KB	Kilobyte
KE	Knowledge Engineering
LS	Logarithmic scoring
MAE	Mean Absolute Error
MAE	Mean Average Error
MAET	Mean Absolute Error Tiered
MB	Megabyte
MCC	Matthews Correlation Coefficient
ML	Machine Learning
MPAA	Motion Picture Association of America
MVL	MovieLabs (the benchmark system)
NPT	Node Probability Table
OO	Object-Oriented
OoBN	Object-Oriented Bayesian Network
OST	Original Sound Track
P2P	Peer-to-peer
PCC	Pearson Product-Moment Correlation Coefficient
PDF	Probability Density Function

QS	Quadratic scoring rule
RIAA	Recording Industry Association of America
ROC	Receiver Operating Characteristic
SS	Spherical scoring rule
SW	Smith-Waterman
TC	Text Classification
TF	Term Frequency
TN	True Negatives
Toran	Torrent Analyser
TP	True Positive
TPR	True Positive Rate
XML	Extensible Markup Language

# Glossary

DS120	Data Set of 121 items classified by human experts and the benchmark system and completely verified (test set)
DS2500	Data Set of 2,500 items classified by human experts and the benchmark system (knowledge set)
DS480	Data Set of 479 items classified by human experts and the benchmark system (validation set)
DSBS	Data set of 45,209 items captured from BitSnoop torrent tracker to evaluate prediction accuracy on independent data
DSMF	Data set of 100 items for evaluating accuracy of fakes and malware prediction
IMDbPY	Python package to retrieve and manage the data of the IMDb movie database about movies, people, characters and companies
MVL	MovieLabs torrent classification benchmark system
Toran	The prototype classifier system we created to test our method



# Notation



`Lucida Sans Typewriter` font is used in the body of text to refer to (parts of) torrent names, name string evidence, regular expressions; and is the primary font in algorithm boxes.

*Cambria Math* font is used to refer to variables, formulas and expressions.

Bayesian Network node names are normally given in italics (e.g. *Title Found*).

Bayesian Network node states are normally given in double inverted commas (e.g. "Video", "Audio", "Other").

Bayesian Network fragments that are unified into a single node on a diagram are shown with a rectangular dashed border.

Bayesian Network graphs show nodes that are observed in pink and nodes that are the focus of prediction in green (appearing as  and  respectively).

# List of Figures

Figure 1: Example of a Torrent Name.....	32
Figure 2: Composition of Data Sets according to Human Classifiers .....	48
Figure 3: DS2500 and DS480 Composition according to Average and Majority Voting .....	49
Figure 4: Verified Composition of DS120.....	52
Figure 5: Example of a Partially Classified Item in BitSnoop Data Set .....	56
Figure 6: Example of a Misclassified Item in BitSnoop Data Set.....	56
Figure 7: Composition of DSBS According to BitSnoop.....	57
Figure 8: Naïve Bayes Illustration.....	61
Figure 9: Possible Votes that Produce Distributions in Table 11 .....	72
Figure 10: Torrent Name and Movie Title Aligned .....	76
Figure 11: Basic BN for Fakes Detection.....	85
Figure 12: Basic BN for Fakes Detection Example after Evidence Propagation.....	86
Figure 13: Revised Example Model for Fakes Detection.....	86
Figure 14: Possible Outcomes of the Fakes Detection Model: a) Show the marginal values before propagation, b-e) Show the values after propagation with the given observations .....	88
Figure 15: Extended Example Model for Fakes Detection.....	88
Figure 16: Basic BN for Input, Real Medium, Fake and Malware .....	98
Figure 17: Converging Connection .....	98
Figure 18: Diverging Connection .....	99
Figure 19: Serial Connection .....	99
Figure 20: Example of using Ranked Nodes to Assess Classifier Accuracy.....	104
Figure 21: Cause-Consequence Idiom .....	105
Figure 22: Cause-Consequence Idiom Example.....	106
Figure 23: Definitional-Synthesis Idiom (Fenton & Neil 2012d).....	106
Figure 24: Definitional Idiom Example of a Deterministic Formula .....	107

Figure 25: Synthesis Example for String Properties before Divorcing .....	107
Figure 26: Synthesis Example for String Properties after Divorcing .....	108
Figure 27: Measurement Idiom (Fenton & Neil 2012d).....	108
Figure 28: Fakes Detection as Example of Accuracy Measurement Idiom Instantiation .....	109
Figure 29: Extended Fakes Detection Model Demo.....	110
Figure 30: Induction Idiom Example .....	111
Figure 31: Effects of Contextual Differences on Learnt Distribution .....	112
Figure 32: Basic Overview of the Current Model.....	113
Figure 33: Example of a Fake Torrent.....	117
Figure 34: Model Fragment – Real Medium, Input, Fake, Malware.....	119
Figure 35: Current Model Fragment – Real Medium, Fake, Advertised Medium .....	121
Figure 36: Relationship between <i>Fake</i> , <i>Real Medium</i> and <i>Advertised Medium</i> .....	123
Figure 37: Example of File Size Distributions.....	125
Figure 38: Current Model Fragment – Advertised Medium and Several Signature Nodes .....	127
Figure 39: Video Editing Software Torrent with Weak Movie Signature .....	129
Figure 40: <i>Video: TV Signature Detected</i> NPT Graphs (Driven by Original Data and Generated) ..	130
Figure 41: <i>Language Detected</i> NPT Graph .....	136
Figure 42: BN Fragment – Option for Modelling Porn and Malware .....	137
Figure 43: Current Model Fragment – Porn Detection.....	137
Figure 44: <i>Porn Signature Found</i> NPT Graphs .....	139
Figure 45: Example of a Torrent Name with Multi-Category Title Match .....	143
Figure 46: Title Detection Example – Current Model Fragment .....	144
Figure 47: Normal Use of the Risky Title Detection Mechanism for New Torrent Items .....	146
Figure 48: Non-Fake Can Match as Risky Title .....	147
Figure 49: Evidence Entering into the Classifier BN Model .....	150
Figure 50: Torrent Name Example with Disposable Data .....	154

Figure 51: Medium Category Associations of Signature <b>live</b> .....	157
Figure 52: Porn IP Signature Pattern.....	164
Figure 53: Example of Torrent without File Type Evidence .....	171
Figure 54: Obfuscated Torrent Name Alignment .....	172
Figure 55: Impact of Coefficient $c$ on the <i>BST</i> for Examples #2 and #4 from Figure 9 and Table 11 .....	198
Figure 56: Medium Confusion Matrices for DS2500 and DS480 .....	208
Figure 57: Medium Confusion Matrices for DS120.....	210
Figure 58: ROC Curves for Medium in DS2500, DS480 and DS120 by All Agents .....	214
Figure 59: Confusion Matrices for BitSnoop Data Set .....	217
Figure 60: ROC Graph and AUC for BitSnoop Data Set .....	218
Figure 61: Interpretation of Evidence in <i>CSI .Miami .S10 .WEB-DLRIP</i> Torrent.....	225
Figure 62: Complete Example for <i>CSI .Miami .S10 .WEB-DLRIP</i> Torrent.....	226
Figure A.1: Processed Torrent XML Record Example #1 .....	234
Figure A.2: Processed Torrent XML Record Example #2 .....	235
Figure A.3: Processed Torrent XML Record Example #3 .....	236
Figure E.1: Example of Graph Moralisation .....	239
Figure E.2: Graph Triangulation Example .....	240
Figure E.3: Clusters and Separators .....	241
Figure E.4: Junction Tree Example .....	241
Figure E.5: Illustration of Evidence Collection and Distribution Sequence .....	242
Figure F.1: File Size Distribution in Medium Categories by Experts on 2500 Sample .....	244
Figure F.2: File Size NPT Plots in Current Model .....	246
Figure G.1: Example – Movie (Audio and Video Signatures).....	247
Figure G.2: Example – Television or Radio Recording (Size and Date) .....	247
Figure G.3: Example – Movie and No OST Signatures .....	248
Figure G.4: Example – Movie and OST Signatures, with File Size .....	248
Figure G.5: Example – Movie and OST Signatures, but No File Size .....	248

# List of Tables

Table 1: Data Meaning of Torrent Name Example from Figure 1 .....	32
Table 2: Torrent Name Examples .....	40
Table 3: MovieLabs Classification Taxonomy .....	41
Table 4: Our Classification Taxonomy (* Original Sound Track) .....	42
Table 5: Original and Filtered Count of Titles per Category in the Title Database .....	45
Table 6: Population Estimate based on DS2500 with Margins .....	50
Table 7: Fakes and Malware Distribution in DSFM.....	54
Table 8: Categories in the BitSnoop Data Set and Mapping to Toran Taxonomy .....	55
Table 9: Term Weights Illustration for Example in Table 1 .....	62
Table 10: Terms of Accuracy .....	64
Table 11: Example Predictions for Item that is “Video: Movie” .....	72
Table 12: Accuracy Metrics Calculated for Examples from Table 11 .....	74
Table 13: Example of a Movie Title and Torrent Name for Alignment .....	76
Table 14: 3-Gram Example of ‘Matrix’ .....	77
Table 15: Alignment Example under Different Rules.....	78
Table 16: Example of Alignment and Score Matrix .....	79
Table 17: Illustration of Fakes Detection Test .....	83
Table 18: NPT for <i>Torrent is Fake</i> in the Basic Model .....	85
Table 19: NPT for <i>Evidence of Fake Detected</i> in the Basic Model .....	86
Table 20: NPT for <i>Evidence for Fake Detected</i> Example with 2 Parents .....	87
Table 21: NPT for <i>Evidence of Fake Detected</i> in Accuracy Idiom Example .....	109
Table 22: NPT for <i>Detection Accuracy</i> in Accuracy Idiom Example .....	109
Table 23: Original Medium Category Proportions Estimated by MovieLabs.....	114
Table 24: Proportions of Sub-Categories Provided by Humans and Amended by MovieLabs ....	115
Table 25: NPT for <i>Real Medium</i> in Current Model .....	116

Table 26: Fakes & Malware Preliminary Study Summary .....	118
Table 27: NPT Fragment for <i>Fake</i> in Current Model .....	119
Table 28: NPT Fragment for <i>Malware</i> in Current Model .....	120
Table 29: NPT Fragment for <i>Advertised Medium</i> in Current Model (Not Fake) .....	121
Table 30: NPT Fragment for <i>Advertised Medium</i> in Current Model when Fake is True (non-normalised probabilities).....	122
Table 31: File Size Ranges .....	124
Table 32: Movie Torrent Example with Audio Signature .....	127
Table 33: Associations between Medium Categories .....	131
Table 34: Mapping for <i>T</i> and <i>M</i> from Table 33 .....	132
Table 35: Generating Signature NPT Column Example.....	134
Table 36: NPT Fragment for <i>Date Detected</i> .....	135
Table 37: NPT Fragment for <i>Year Detected</i> .....	136
Table 38: NPT Fragment for <i>Subtitles Detected</i> .....	136
Table 39: NPT for <i>Porn</i> .....	138
Table 40: Example – Torrents with Porn Signatures but Actually Not Porn.....	138
Table 41: <i>T</i> and <i>M</i> Parameters for <i>Porn Signature Found</i> NPT .....	140
Table 42: NPT for <i>Porn Studio Found</i> in Current Model .....	140
Table 43: NPT for <i>Porn Actor Found</i> in Current Model.....	141
Table 44: NPT for <i>Found in DB</i> in Current Model (non-normalised probabilities) .....	143
Table 45: NPT for <i>Found Risky Title</i> in Current Model .....	145
Table 46: Basic Signature Example.....	152
Table 47: Example – Torrent Names with HDTV and HDTVrip Signatures .....	153
Table 48: A Few Examples Torrent Names Matching the <b>torrents</b> Signature.....	155
Table 49: A Few Examples Torrent Names Matching the Special TV Signature .....	163
Table 50: Example Torrents for Signature Detection and Filtering Illustration.....	169
Table 51: Signatures Detected in Torrents from Table 50 .....	169

Table 52: Cumulative Signature Strength from Table 51 .....	170
Table 53: Torrent Names from Table 50 after Filtering .....	170
Table 54: Matching Titles with a Gap and without.....	172
Table 55: Title Alignment Substitution Table .....	173
Table 56: Title Alignment Configuration .....	173
Table 57: Actual and Normalised Alignment Scores for Table 54 .....	175
Table 58: Generating 3-grams .....	176
Table 59: n-gram Scores for the Example in Table 58.....	176
Table 60: Bonuses and Penalties for Title Matching .....	183
Table 61: Virtual Evidence for <i>Found in DB</i> Example.....	184
Table 62: Medium Prior Distributions for Humans and MVL .....	191
Table 63: Porn Prior Distributions for Humans and MVL.....	191
Table 64: Example of Translating Full to Partial Category Distributions .....	192
Table 65: Examples when an Expert is Wrong, MVL Partially is Right and Toran is Correct.....	193
Table 66: Deriving a Single Estimate of the ‘True’ State from Expert Verdicts.....	194
Table 67: Equation Components and Other Parameters for <i>BST</i> Example, $c = 10$ .....	196
Table 68: Calculating <i>BST</i> ( $c = 5$ ) and <i>AE</i> ( $c = 30$ ) for Examples in Figure 9 and Table 11 .....	197
Table 69: Illustration of Tiered Score Metric Being Non-Discriminative of Super-Category Size	197
Table 70: Possible Brier Score for ‘Unknown’ Predictions Depending on the True Item State .....	200
Table 71: Prediction and Evaluation Parameters .....	204
Table 72: Average Error of MVL and Toran T on DS2500 and DS480 with 95% Confidence Interval.....	205
Table 73: Title Matching Improves Results for Movies, TVs and Games in DS2500 and DS480...	206
Table 74: Average Error of HP, MVL and Toran T on DS120.....	206
Table 75: Title Matching Improves Results for Movies, TVs and Games in DS120.....	207
Table 76: Data for Average Accuracy on DS2500 and DS120 .....	212
Table 77: Average Accuracy on DS2500 and DS120 .....	212

Table 78: AUC for Porn and Medium for All Agents on all Data Sets .....	215
Table 79: Average Error Metrics per Agent in BitSnoop Data Set .....	216
Table 80: Data for Porn Detection Accuracy .....	219
Table 81: Porn Detection Accuracy and Error .....	219
Table 82: Data for Fake and Malware Detection Accuracy .....	220
Table 83: Fake and Malware Detection Accuracy and Error .....	220
Table 84: Evidence Strength for Priko1isty.UNRATED.2009.HDRip.MP3.700MB.avi Torrent.....	225
Table F.1: File Size Distribution in Medium Categories by Experts on 2500 Sample.....	243
Table F.2: NPT for <i>File Size</i> in Current Model .....	245
Table I.1: Complex TV Pattern Parts .....	250
Table J.1: Torrent Name Filtering Examples .....	251



# List of Algorithms

Algorithm 1: Generate Column for <i>Signature Found</i> NPT.....	132
Algorithm 2: NPT Normalisation.....	133
Algorithm 3: Gather Signature Frequencies .....	158
Algorithm 4: Weigh Category Counts (Continuation of Algorithm 3).....	159
Algorithm 5: Normalise and Filter Associations (Continuation of Algorithm 4).....	160
Algorithm 6: Updating Signature Associations (Continuation of Algorithm 5).....	161
Algorithm 7: Detect Signatures and Filter Torrent Name.....	167
Algorithm 8: Record Signature Observations.....	168
Algorithm 9: Detect and Filter Porn Studios and Actors .....	168
Algorithm 10: Score Match.....	174
Algorithm 11: Score Gap .....	174
Algorithm 12: Calculate Overlapping 3-grams .....	177
Algorithm 13: Calculate <i>SnormG</i> .....	178
Algorithm 14: Find Best Record Matches for an Item (Part 1).....	180
Algorithm 15: Find Best Record Matches for an Item (Part 2).....	181
Algorithm 16: Match Item and Record (Part 1) .....	181
Algorithm 17: Match Item and Record (Part 2) .....	182
Algorithm 18: Match Item and Record (Part 3) .....	183

# Chapter 1

## Introduction

This chapter covers the motivation and gives the necessary introduction to the application domain, defines the research hypothesis and research objectives and explains the structure of this document.

### 1.1. Motivation

The relentless growth of the Internet and its resources (Qmee 2013; Internet World Stats 2014; Cisco 2015a) continues to pose novel challenges. Content and service providers strive to monitor the data consumption in order to serve personalised advertising and perform market research, while Internet users often benefit from receiving automated recommendations based on their preferences and tastes. Indeed, personalisation of online content is now so pervasive that users are conditioned to expect such recommendations wherever they go online. Among the examples of such personalisation are:

- targeted ads provided by big advertisement networks that monitor general activity of a person online and serve ads based on this activity;
- search engine results that are often also tailored to reflect the user interests, so that the same request will produce different results to different people;
- item recommendations by online shops that are based on previous purchases or product page visits;
- local news and weather forecasts showed by news portals based on visitor's location;
- online video streaming services recommending titles to watch based on the history of past items and ratings the user had left; etc.

Cisco estimated the global Internet traffic at 59.9 Exabytes per month in 2014 and that 80-90% of all Internet traffic was primarily video transfer, and that 67% of all traffic was caused specifically by digital TV, video on demand and streaming (Cisco 2015a). According to YouTube, 300 hours of video are uploaded to YouTube every minute (Youtube Press 2015), and in 2012 the number of videos watched per day reached 4 billion (YouTube 2012).

Netflix stated in their Q1 2015 shareholders report (Hastings & Wells 2015) that users streamed a total of 10 billion hours of content through their services in the first quarter of 2015. They do not, however, provide a break down in terms of movies, TV series or other types of video; and nor do they supply an actual number of items watched. Given an average length of a movie around 2 hours and an average length of a TV episode of 40 minutes, this is equivalent to over 55 million movies or over 165 million TV episodes watched per day.

An especially important class of downloadable content – and one which is a major focus of this thesis – is referred to as *BitTorrent* (Cohen 2011; BitTorrent 2015a), or just *torrent*. A combined estimate provided by Cisco (Cisco 2015b) and Sandvine (Sandvine 2014) indicates that BitTorrent traffic accounts for between 5% to 35% of household and mobile traffic, depending on the region.

A BitTorrent file is a shorthand for a file created by Internet users for sharing images, videos, software and other content legally or illegally; and the mechanism for this is provided by a peer-to-peer (P2P) networking architecture where individual nodes, such as users' computers, communicate with each other without a complete reliance on a central server, as opposed to a client-server architecture (Schollmeier 2001).

In many cases the torrents have no conventional metadata or naming standard, so it is very difficult to adequately analyse and classify such items reliably and autonomously.

Torrent files are mostly posted on the Internet by individuals, as opposed to companies, and this makes them very difficult to account for in any terms other than traffic volume. Classically, these files are available on multitudes of websites, called trackers. Zhang et al reported in 2011 that the total number of trackers they discovered was approaching 39,000 although only 728 were operating actively (Zhang et al. 2011). The total number of torrent files collected was over 8.5 million, out of which almost 3 million were actively shared by users. With an exception of a handful of extremely large projects, an average number of torrents served by a tracker was around 10,000.

In 2011 a report by Envisional commissioned by NBCUniversal, a large media and entertainment company, claimed that two thirds of BitTorrent traffic were infringing content (Envisional 2011). In 2014 a report by Tru Optik claimed that the global monetary value of content downloaded from *torrent* networks amounted to more than £520 billion in 2014 (Tru Optik 2014). This figure, however, assumes that everything that was downloaded and presumably watched would otherwise be purchased via official distribution channels. Such an assumption may be indicative of bias in Tru Optik's claims, and ignores the fact that some people may have financial, geographical or language-related barriers to accessing material legally.

With regards to the type of content, Tru Optik claim in the same report that in a typical day people download over 12 million TV episodes and complete seasons, 14 million movies and movie collections, 4 million songs and albums, 7 million games, 4 million software programmes and 7 million pornographic videos; as well as over 9.64 million pieces of content produced by TV networks CBS, ABC, Fox, CW, HBO, FX, NBC, AMC, Showtime and. They do not, however, specify how the classification or identification was made, and nor does Envisional in their 2011 report.

It is crucial to note that companies such as Tru Optik and Envisional may have a strong vested interest in overestimating the volume and value of downloaded

copyrighted content. There is an obvious demand for being able to identify and classify such downloads automatically in a transparent and coherent way, such that unbiased statistical data can be obtained. In fact, this thesis was partly motivated by exactly such a demand by MovieLabs (properly introduced in Section 2.1), a private research lab funded by several major Hollywood studios and heavily involved with developing new methods to analyse torrent traffic.

An important drawback of such reports as the ones produced by Tru Optik and Envisional is the assumption that all BitTorrent content, or even all downloaded content, is illegal, which is a fallacy dismissed by the International Federation of the Phonographic Industry (IFPI), which is an organisation RIAA often turns to for statistics. In their 2015 report IFPI suggest that in 2014 revenue from digital sales, i.e. legal downloads, reached the same figures as revenue from physical sales (IFPI 2015), which demonstrates well the importance of providing better quality statistics about the content being downloaded from the Internet.

Regardless of validity of the claims like the ones by Tru Optik and Envisional, large potential loss of revenue is often a major cause for legal battles between rights holders (and their agencies), such as Recording Industry Association of America (RIAA) or Motion Picture Association of America (MPAA), and popular BitTorrent trackers, who operate websites primarily used for providing downloads of such content. A prominent example was the Swedish court case #B 13301-06 (Stockholm District Court 2009; Stockholms Tingsrätt 2009) against the creators of The Pirate Bay, which was a very popular torrent tracker and served in excess of 10 times more downloads than the second biggest tracker in 2011 (Zhang et al. 2011).

An analogy to help understand the legal BitTorrent concept was provided in a ruling of the Federal Court of Australia:

‘...the file being shared in the swarm is the treasure, the BitTorrent client is the ship, the .torrent file is the treasure map, The Pirate Bay provides treasure maps free of charge and the tracker is the wise old man that needs to be consulted to understand the treasure map.’

In addition to this analogy, it has to be noted that the treasure never actually leaves the place where it was found, and rather self-replicates into the pocket of the one who found it, thus leaving no one deprived of the access to the treasure, but nonetheless raising an issue of opportunity cost to publishers who argue they lost profits because a free alternative was available (Siwek 2006; Dejean 2009).

Although the nature of P2P technology is such that it is often used for illegal file sharing, it is not solely used for piracy. Legal applications of P2P include free software and game distribution, e.g. distributing famous open-source software such as OpenOffice and Ubuntu (OpenOffice 2015; Ubuntu 2015) and others; client distribution for commercial software relying on client-server architecture, such as online game clients, which may also include BitTorrent and other P2P elements e.g. (Enigmax 2008; Meritt 2010; Wikia 2015; CCP Games 2015); crypto-currencies (Nakamoto 2008); file storage sync services (BitTorrent 2015c); internal corporate data transfer (Paul 2012) etc. P2P technology is also used for censorship circumvention as part of virtual private network architectures (Wolinsky et al. 2010).

Some artists and bands release promotional packages on BitTorrent to get the public involved (BitTorrent 2015b). There are over 10 million items available as torrent downloads at the Internet Archive who collect items that are legally available for free to the public (Internet Archive 2016), and an additional catalogue of resources hosting free and legal torrent downloads is maintained (Gizmo’s

Freeware 2015). There is also an argument that online piracy is motivated to a great degree by the lack of a legal and convenient alternatives online (Masnick 2015), and that the impact of piracy is overestimated (Milot 2014) or may even be a positive factor for the industry (Smith & Telang 2009).

An additional benefit to automatic torrent classification and identification may come in the domain of cyber-security and involve early malware detection. Big movie studios or companies operating on behalf of Hollywood studios, such as MediaDefender (Wikipedia 2016), attempt to combat piracy by employing a range of tactics aimed at disrupting file sharing networks. One prominent method is to flood the network with multiple fakes aimed at particular titles that are deemed high interest, for example, titles of recently released Hollywood blockbuster movies, which are highly anticipated. By maintaining a high number of fake downloads the anti-piracy entities reduce the chances of a common user downloading an actual movie. Once the user downloads a fake, they will normally remove it from their machine, thus limiting the fake's potency, which is why this tactic is only employed for a particular title for a short period of time while the movie is considered to be the most relevant. This minimises losses by tackling the free downloads at the time most critical for cinema ticket sales.

Fakes are also often posted by other malicious actors such as hackers. Most fakes are either trailers or broken videos. A considerable proportion of such items, however, also either contain an infected executable file or a link to a malicious web page employing social engineering methods to coerce an unsuspecting user into enabling an attacker to infect their machine with malware or bot-net inclusion. While most of these items are disguised as movies, this is also relevant to a lesser extent to other medium categories, such as music, in which case an advertisement video may be flooded into the file sharing network masquerading as a live concert recording (Angwin et al. 2006).

## Claimed Benefits

Corporations can benefit from exploiting the market research, including but not limited to:

- evaluating brand and title popularity unaffected by monetary aspects of the market;
- estimating potential losses due to piracy with a greater degree of accuracy;
- matching real world events, such as movie releases or announcements, to the download activity;
- identifying market niches where legal alternatives are lacking e.g. providing an official dubbing or subtitles in languages where no formal alternative exists for certain movies or TV series, despite the title's popularity;
- attempting to relate user buying patterns with their download preferences.

The individual users, however, may also find a benefit from automatic tools being able to:

- estimate the risk that a file is a fake and does not contain what the file name advertises;
- predict the risk of the file containing malware based purely on its properties (name, size, source etc.) before any download is attempted;
- provide tailored recommendations of downloads or products based on the download profile of the user.

Uncertainty lies at the heart of classification, even when undertaken by humans who sometimes find it difficult to classify an item fully into a single category, and may be more comfortable to use a number of weighted categories to describe that item. The issue is especially problematic for media content available online,



because it is ultimately impossible to conclusively determine its true identity until the file is completely downloaded and analysed in full. So it is natural to express an uncertain belief in the likely category instead of trying to use a hard classification. Bayes' theorem (see Section 3.1 for a detailed introduction) is especially suitable for expressing a probability of an ultimately unobserved hypothesis (e.g. true state of the item), given some factual evidence. The potential of this theorem is fully realised in Bayesian network (BN) modelling (see Section 3.2), which allows construction of a network of related variables or events and makes it possible to model their relationships. Crucially, we can incorporate our prior beliefs and expertise into the model and achieve accurate results when data are scarce or even unavailable.

Data scarcity is especially pertinent for the torrent identification and classification problem since, in most cases, the only 'data' available to us on an individual torrent are those which can be extracted from the *torrent* name.

{www.scenetime.com}Law.and.Order.SVU.S13E10.480p.WEB-DL.x264-mSD.exe

Figure 1: Example of a Torrent Name

Figure 1 presents an example of such torrent name, and Table 1 provides a breakdown of the name into meaningful pieces of data.

Data	Meaning
www.scenetime.com	Tracker website
Law.and.Order.SVU	TV series 'Law & Order: Special Victims Unit'
S13E10	Season 13 episode 10
480p	Video resolution
WEB-DL	Video capture source type
x264	Video encoding
-mSD	Distributor signature
exe	File type extension – software

Table 1: Data Meaning of Torrent Name Example from Figure 1

All inference has to be based on the file name along with some prior knowledge, which is why we believe that it must be addressed from a Bayesian probabilistic perspective. For example, we can also give a prediction with a particular degree of

certainty whether a file is pornographic ('porn' onwards), fake or malware; and supply extra information about the evidence retrieved from the file name, which can explain why a particular prediction was made. Combining all this information into a well-structured format is the ultimate way to enable further analysis as indicated above, benefitting both the end users and the service providers. By solving the problem of *torrent* classification and identification we would also be able to define a coherent method and provide a range of tools for solving similar problems. A basic example of a similar problem is on-line recommendation that holds item classification to be a pre-requisite. A more advanced example is identifying a shopping category by analysing a search request string typed by an online shopper.

In contrast to the work on network traffic classification, such as in (Moore & Zuev 2005; Charalampos et al. 2010; Bashir et al. 2013), where the network behaviour or actual network packet-related data are analysed directly, this thesis is only concerned with analysing file name and size which describe a torrent item.

## 1.2. Research Hypothesis and Objectives

The main research hypothesis of this thesis is that it is possible to achieve quantifiable improvements to the accuracy and utility of the current state-of-the-art of automated classification and identification of downloadable media content based on minimal data. The focus is on deriving an underlying probabilistic model that incorporates expert judgement along with data, which also enables us to perform further rich analysis on the post-processed data. The hypothesis is underpinned by the following objectives:

1. To develop an automated classification system, based on a probabilistic model that can deliver accurate and rich probabilistic classification of files without the need to maintain any media database and using minimal input such as file name and size.

2. To show that, when the system in 1) employs (as, for example, the MovieLabs system does) to a database of item titles, it is possible to provide improved probabilistic classification and identification, including estimation of probability of fakes and malware.
3. To develop a general and rigorous metric-based framework for assessing the accuracy of systems that perform media classification and identification – even in the absence of an oracle for determining the ‘true’ state of content – so that the performance of the proposed new system can be formally compared against alternatives such as the MovieLabs system and human judges when presented with the same input data.
4. To perform extensive empirical validation of the system based on the framework established in 3).

### 1.3. Structure of the Thesis

Chapter 2 introduces the MovieLabs benchmark system and our alternative prototype system. It explains the data we used, and how we obtained, analysed and processed them. It defines the classification hierarchy and covers the data samples we collected. A literature review and an overview of the methods and technologies used in the thesis are also provided.

Chapter 3 covers other underlying topics which form the theoretical basis for the thesis, namely, Bayesian networks and modelling, and describes the novel BN we use to model the uncertainty of classification predictions.

Chapter 4 explains how we define and capture the evidence used as input for our BN model. The two most important pieces of evidence to consider are observations related to file size and medium type signatures detected in a file name or any possible title matches in that file name.

In Chapter 5 we define the framework for comparing classification results produced by different agents, and propose an evaluation metric that extends classical metrics and enables adequate analysis of classification performance on a multi-level hierarchy of categories with varying number of classes in each category.

In Chapter 6 we compare and contrast the results achieved by humans, the benchmark and our prototype systems.

We conclude the thesis in Chapter 7 and summarise the contribution from the previous chapters and discuss possible future work and direction of the research.

# Chapter 2

## Background and Data

This chapter provides a detailed analysis of data used and collected throughout this research project, introduces the MovieLabs benchmark system and our alternative prototype system, in addition to reviewing state-of-the-art of the topics, relevant to data processing, namely, information retrieval, classification and classifier evaluation.

The chapter is structured as follows: Section 2.1 briefly introduces the benchmark system and our prototype. Section 2.2 explains the primary input data e.g. torrent information. Section 2.3 defines the category hierarchy used for classification. Section 2.4 outlines the import procedures for auxiliary input data e.g. titles. Section 2.5 covers the data samples. Section 2.6 covers the relevant theory in fields of classification and classifier evaluation. Section 2.7 introduces string alignment which is relevant for title identification.

The material in Sections 2.1 to 2.5 is, to the best of our knowledge, a novel contribution and is focused on our approach to the problem domain.

### 2.1. The Benchmark and Prototype Systems

#### a) *Benchmark*

Among the organisations especially interested in solving the *torrent* identification and classification problem are the big Hollywood movie studios since they not only provide the most significant investment in the original movie content, but are most at risk from Internet piracy. MovieLabs is a private research lab that is funded by six major US Hollywood studios to accelerate the development of technologies essential to the distribution and use of consumer media (MovieLabs 2016).

MovieLabs conduct continuous in-depth research of the material posted on *torrent* networks. They develop and maintain a proprietary system, which we shall subsequently call MVL that allows them to capture, organise and analyse a very large collection of torrent files posted on multiple online platforms throughout the Internet. The primary target of the MovieLabs system is to detect torrents that contain movies published by the main Hollywood studios, but they also try to capture items of other categories.

We believe that the MVL system represents a viable benchmark, against which a new automated approach can be tested. MovieLabs recognised that, given the complexity of torrent names and obfuscation involved, it is increasingly difficult for automated systems like theirs to achieve good results with a deterministic approach (MovieLabs 2012).

While the details of the MVL classification engine are proprietary, it is known that it is a rule-based approach that does not address uncertainty while analysing the data, and is only capable of making hard classification or identification decisions with no regard to the uncertainty of the outcome (MovieLabs 2014). Hence, the classification decisions are non-probabilistic and are based mostly on running regular expression matching against a list of titles that they are seeking to detect, and then looking at a limited number of keywords associated with a particular category. The MVL system also attempts to retrieve meta-data from other online platforms that store torrent classifications, and hence relies to a degree on other black-box systems.

In order to compare our method to MVL, we picked a limited number of items from the MovieLabs' database of torrents and separated it into several data sets, covered in more detail in Section 2.5.

We extend the keyword system, originally used by MovieLabs, in Chapter 4 to build a more flexible architecture that allows coherent encoding of expertise from multiple sources, agents or experts.

b) *Prototype*

We developed a prototype classifier system called Toran (Torrent Analyser), which is written in Java and uses the AgenaRisk API (Agena 2016a) to perform Bayesian computations. Toran takes in torrent name and file size as parameters and returns a number of probabilistic predictions where each variable's state is assigned a predicted probability.

The Toran output is a report in XML format (Extensible Markup Language), described in (W3C 2008). The XML schema of the report can be found in Appendix A and a few examples of torrents processed into this format can be found in Appendix Figures A.1, A.2 and A.3. Appendix B provides an example of a complete Toran's XML report.

The report contains multiple torrent records, and each record specifies:

- original properties:
  - torrent hash code identifier
  - torrent name string
  - file size
- observations extracted from the filename:
  - sub-strings associated with medium categories
  - title matches
- filtered file name (after all known removable signatures are filtered out)

- variable predictions (as a map of states and corresponding probability values):
  - porn
  - risk of fake
  - risk of malware
  - medium category

Subsequent chapters explain in detail the Bayesian model and Toran configuration. The information included into the report makes it possible to explain how Toran arrived at its predictions and allows further analysis.

## 2.2. File Data

MovieLabs provided us with a large database of torrent files they collected over several years, as well as a feed that prints newly detected and processed items in real time. The following primary pieces of data were reliably available:

- Hash Code* is a pseudo-unique torrent identifier, which takes into account both the torrent name and its content. A particular torrent always resolves to the same hash code. We use the hash code as item identifier when processing torrents.
- Torrent Name*, also called file name, is always defined by the user who is posting the torrent, and does not necessarily follow any naming notation (see Table 2 for examples). Even though in most cases such names are descriptive of the content, torrents exist with names either giving false information (e.g. malware masked as a popular movie, see Table 2 #2), or just being unreadable or corrupt (e.g. `◆◆◆◆`). In other cases information contained in the string is too little or ambiguous to perform any analysis (e.g. 000143288\_250), or it could be in a foreign language (e.g. 사랑과 도주의 나날.zip).



#	File Name String
1	How.I.Met.Your.Mother.S07E24E25.HDTV.XviD-NYDIC
2	Cpasbien_The_Interview_(2014)_FANSUB_XviD_downloader.exe
3	Carcedo - Un español frente al holocausto [8473] (r1.1).epub
4	Kim Kardashian Playboy Pics
5	[ www.torrent.com ] - Million.Dollar.Listing.S07E07.x264-YesTV
6	Plebs.S02E03.PDTV.x264-RiVER
7	House Of Anubis S02e71-90
8	PAW.Patrol.S01.HDTRip.x264.960x(semen_52-TNC)
9	Revenge - Temporada 4 [HDTV][Cap.402][V.0.Sub. Español]

Table 2: Torrent Name Examples

- c) *File Size*: bytes, kilobytes (KB), megabytes (MB) or gigabytes (GB); as most files fall into the range between 1 MB and 1 GB we convert size to MB for uniformity. When little information is available the file size can provide at least some possibilities for classification because it is the piece of evidence that we always have available.
- d) A number of other attributes provided by the MovieLabs database are not used by the current method, but could be incorporated in the model as explained in Future Work Section 7.3.

## 2.3. Class Taxonomy

The class taxonomy used by MovieLabs can be seen in Table 3.

Category Level 1	Category Level 2	Category Level 3
Video	Movie	Trailer
	TV	Anime
	Adult	
Audio	Music	Soundtrack
	Podcast	
Software	Application	PC
		Mobile
	Game	Console
		PC
		Mobile
Update		
Image		
Text	Magazine	
	Book	Comic
Unknown		

Table 3: MovieLabs Classification Taxonomy

To achieve the objectives set out in Chapter 1, it was crucial to develop a refined version of the class taxonomy because of a number of obvious weaknesses in the original in Table 3. For example:

- There is non-orthogonality in how “Adult” is a sub-category of video, although almost any form of media may feature adult content.
- There are no provisions in MVL to attempt to detect fakes or malware.
- Due to the deterministic nature of MVL it is unable to express uncertainty and hence has to fall back on the catch-all “Unknown” class when it does not have enough information.

To address these issues, while retaining the core MovieLabs classification requirements, we adopted the revised taxonomy in Table 4, which also illustrates how classes from MovieLabs can be translated into the new hierarchy.

Super-Category	Sub-Category	MovieLabs Category Equivalent
Audio	Audio: Music	Audio: Music
	Audio: OST*	Audio: Music: Soundtrack
	Audio: Other	Audio: Podcast
Image		Image
Mixed		N/A
Software	Software: Game	Software: Game
	Software: Other	Software: Application
Text	Text: Book	Text: Book
	Text: Magazine	Text: Magazine
	Text: Other	N/A
Video	Video: Movie	Video: Movie
	Video: Other	Video: Movie: Trailer Video: Adult
	Video: TV	Video: TV

Table 4: Our Classification Taxonomy (\* Original Sound Track)

The key points to note are:

- There is no “Unknown” category since the major objective of our Bayesian probabilistic approach is that every item’s uncertainty is characterised by probability values associated with each category.
- We simplified the classification by reducing it to two levels of abstraction for practical reasons explained in more detail in Section 3.5.
- “Audio: Soundtrack” is a separate class from “Audio: Music” that is needed because it is common for a torrent that is the soundtrack of a movie to have the *same* (or very similar) title as a torrent that *is* the movie, making the classification especially challenging.
- We added the “Mixed” category for rare cases when a torrent contains a mixture of different types of files (e.g. a movie with soundtrack and additional materials; or a collection of movies, games, comics etc. that belong to the same franchise) and it is impossible even for a human expert to reliably decide on a single category classification.

- From a consultation with MovieLabs we concluded that items they classified as “Video: Adult” are normally short porn videos, which fall under “Video: Other” category in our classification.

In relation to the hierarchy in Table 4, elsewhere in the thesis the terms ‘partial’ or ‘full’ classifications refer to cases where only super-category or the actual sub-category were identified respectively. So, for example, for a movie item, its partial classification is “Video” and its full classification is “Video: Movie”.

## 2.4. Title and Names Databases

In order to attempt identification of files as movies, TVs or games we require an extensive list of titles against which to match the file names. The plain text data files provided by the Internet Movie Database (IMDb 2016) suit our purpose well enough as a proof of concept. We used the IMDbPY framework (IMDbPY 2015) to import the data into a MySQL database (MySQL 2015). The composition of the original IMDb data is quite complex, so we only cover the parts relevant for this thesis.

The most significant information for us was:

- the title itself;
- its production year, which is very important as it normally appears in file names and also helps distinguish between same titles released at different times;
- the category of the item translated into our taxonomy;
- whether the title is an episode and of which TV series or show.

Movie titles in the database also contain some porn movies, which is useful for porn detection, but the list is very limited. Table 5 outlines an estimated distribution of content titles found in the original IMDb data, which is polluted to

a degree by the imperfect import method that produced a number of duplicates and some broken relations between items.

In addition to a large list of TV shows, episodes and movies, the data set included a limited number of gaming titles and even some alternative names to capture cases such as when the same movie was released under different titles around the world including official translations into other languages. It is important to note, however, that this list is not comprehensive, and contains a lot of noise produced by the IMDbPY import procedure.

We attempted to improve the database by removing duplicates and very ambiguous titles as the IMDb seems to store some impractical data e.g. titles '2' (IMDb 2015b), '01' (IMDb 2015a), 'Air' (IMDb 2015c) etc., which are entries for abandoned projects, works in progress, place holders or other unreleased items that may be subject to change in future. We also filtered out some erroneous data imported from IMDb plain text files by IMDbPY. The basic filtering rule in both these cases was a missing production year, which accounts for 14.42% of the total number from Table 5. We decided to import only those titles from IMDb which had been previously rated by their visitors.

Additionally, the following Boolean criteria were applied to each title item:

- not an episode;
- not a short video (but can be a series comprised of short episodes);
- has production year.

The rationale is to limit the data to significant items only and reduce the chance of a false positive identification, which inevitably increases with a bigger vocabulary of longer titles. We also decided to ignore TV episode names because they were observed extremely rarely in torrent names (1 out of 2500 in one of the data sets), yet required a lot of processing time to match, and contributed to many false positives.

<b>Title Category</b>	<b>Original Count</b>	<b>Filtered Count</b>
TV Episode	1,812,676	0
Movie	1,018,507	344,176
Game	14,125	6,169
TV Series and Shows	110,796	43,033
Alternative titles	389,549	233,529
<b>Total</b>	<b>3,345,653</b>	<b>626,907</b>

Table 5: Original and Filtered Count of Titles per Category in the Title Database

While importing the titles, apart from mapping them into our taxonomy, we introduced a property ‘stripped’ that represents the title string with sequences of any non-alphanumeric Unicode characters replaced by a space. This new attribute is used later to compare a title item to a torrent name. After importing titles and their alternative naming we found a large number of duplicate entries in the ‘stripped’ column. This was caused by three different cases:

1. multiple same titles released in the same year;
2. original titles clashing with alternative naming from other titles;
3. multiple same alternative naming for one or more titles; so we had to prune these as well.

Final title data can be found in Appendix Section C.1. Chapter 4 explains in detail how we use the titles to improve classification. There are many limitations to the ways we exploit title data and they are highlighted in the Future Work Section 7.3 along with some suggestions for improvement.

To enable porn detection we captured some of the names of porn actresses from Adult Film Database (Adult Film Database 2015) since they appear very often in porn file names. Extracting suitable names requires filtering to prevent a large number of false positive identifications due to some actors’ names being either too short or too common. We restricted the list to actresses only, because names of male actors rarely appear in file names. We set the career starting year filter to 1980 because older actors appeared in a tiny number of file names. We then limited this

list (see Appendix Section C.2) to unique names only and filtered out names where either the name or the surname were shorter than 3 characters long, or the whole name was shorter than 9 characters long. While this approach provided a starting ground for improved porn detection, a more appropriate data set is in the long term improvement plans. We expanded this information by a short list of porn studios (see Appendix Section C.3), which can also be sometimes detected in the torrent name.

## 2.5. Data Samples

As indicated earlier, torrent names are formed voluntarily and freely by their individual publishers and therefore do not abide by any specific naming rules, formats or convention. This leads to names that can be inaccurate or plainly misleading. Some names are obfuscated either by mistake, or intentionally, to disable automatic detection of illegal or malicious content. Hence, often the torrent file name may provide little insight into its true contents. The only way to truly identify and classify a torrent is to download it and run it all the way through – an impossible task for anything other than a small sample. There have been very small samples analysed manually for legal and research purposes (MovieLabs 2012), but most research is based on analysis of aggregated statistics as indicated in (Smith & Telang 2012).

Amazon Mechanical Turk (Amazon Mechanical Turk 2015) is an online crowdsourcing platform that enables, for example, researchers to contract human participants to perform experiments, such as torrent identification and classification given a particular taxonomy. An attempt was made to develop a ‘ground truth’ sample of 2500 items classified and identified by human participants of the Amazon Mechanical Turk in (Tonkin et al. 2013). This study demonstrated that the performance of untrained participants was poor and unfit to qualify as a reliable sample for baseline comparison.

In an attempt to address this issue we hired and trained three individuals (called later HP for 'human panel') to provide us with classifications and identifications for our own sample set. The original set of items collected (DS2500) formed our own basis for domain knowledge, which was incorporated into Toran together with MovieLabs' expertise and title database. However, when we attempted to verify the true contents of the items in this set, it became apparent that it was impossible due to the majority of items being non-downloadable.

We proceeded to collect another set of items from recently captured torrents and gathered 600 items out of which 121 items were successfully verified. Consequently, we divided this collection into DS120 (the set of 121 verified items) and DS480 (the remaining 479 items) such that the latter would be the validation set and the former would serve as the ultimate test set with truly known classifications and identities of items.

The human classifiers were of European origin, two males and a female, in their twenties. Two of them have higher education and they all speak English and Russian fluently, which is important since these languages are the top two used in torrent naming. All humans classified items independently from each other, at their own pace during multiple sessions. Although the same copy of the data set was issued to the classifiers, they did not always process items in the order given. It is possible that their accuracy was declining within each session due to fatigue, but they were free to design their own schedule for processing items.

The classifiers were instructed to choose the category that they felt could best be associated with each item. If in doubt, they were supposed to either select the most likely category, or choose 'unknown' if truly unsure. In addition to selecting medium category they also classified items as 'porn' or 'not porn' with a possibility to fall back to 'unknown' in the uncertain cases.



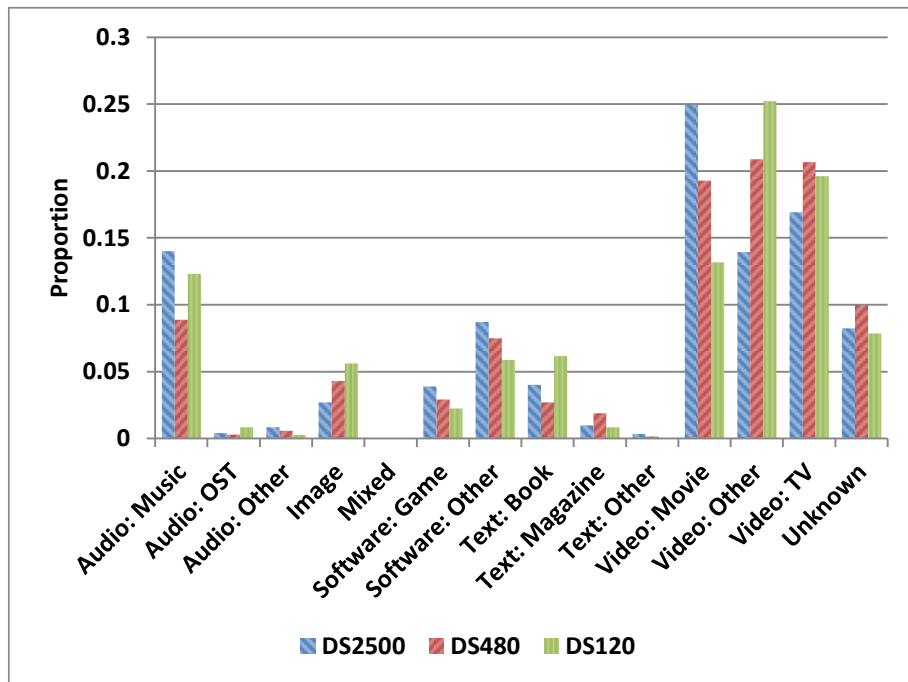

Figure 2: Composition of Data Sets according to Human Classifiers

The category distributions given by human classifiers, including the proportion of ‘unknown’ verdicts, for DS2500, DS480 and DS120 is shown in Figure 2.

Some items were classified by humans into different categories, be it in error or resulting from a different understanding of the class taxonomy. In order to choose a single human classification we employed a majority vote strategy, such that a category is selected for an item if it has at least 2 out of 3 votes. This classification can then be used to compare against a prediction made by an automated classifier. If, however, a classification could not be established by majority vote or it was ‘unknown’, the item would not be used to estimate performance of automated classifiers.

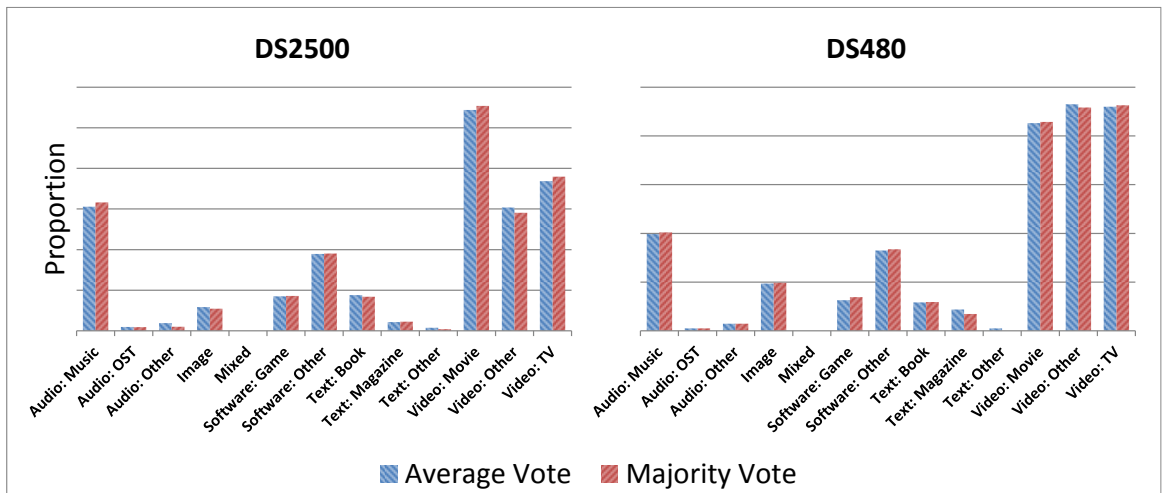

Figure 3: DS2500 and DS480 Composition according to Average and Majority Voting

Figure 3 compares class distribution in DS2500 and DS480 according to average voting versus majority voting. Note that this strategy is irrelevant for DS120 because it contains verified items and predictions made by automated agents are evaluated against the real state of items, rather than against the human approximation of the true state.

a) *DS2500: Knowledge Set*

We could not use items from (Tonkin et al. 2013) data set as they did not include item hash identifiers, so we collected a sample of the same size from the MovieLabs database. The collection method relies on requesting a limited number of items from the database by supplying a portion of a hash code as prefix. It is unclear whether the MVL attempts to return a representative sub-sample as a response to such query. Tonkin et al. compared a few such sets and concluded that they share a similar category (as classified by MVL) spread and torrent discovery date spread. Using Bayesian inference (assuming uniform priors for the different categories), we have calculated the posterior population distributions for each category, based on observed frequency (by majority vote) of categories in DS2500.

Table 6 shows the mean and 95 percentile ranges for these posterior distributions (in classical statistical terms these correspond essentially to the 95% confidence intervals, although strictly – and more usefully - what they tell is that there is a

90% chance that the true value lies between the stated range, e.g. 14.56 to 17.02 for the true percentage of items in the category “Audio: Music”).

Category	DS2500 Count	Estimated Mean % Value	Population Estimate Margin Percentile	
			Lower (5%)	Upper (95%)
Audio: Music	321	15.78	14.56	17.02
Audio: OST	9	0.50	0.26	0.79
Audio: Other	10	0.54	0.30	0.84
Image	55	2.74	2.17	3.36
Mixed	0	0.05	0.00	0.15
Software: Game	87	4.31	3.61	5.06
Software: Other	193	9.50	8.50	10.54
Text: Book	85	4.21	3.51	4.95
Text: Magazine	23	1.17	0.81	1.59
Text: Other	4	0.25	0.10	0.45
Video: Movie	562	27.60	26.16	29.06
Video: Other	295	14.50	13.31	15.71
Video: TV	385	18.91	17.62	20.23

Table 6: Population Estimate based on DS2500 with Margins

We may draw a general impression of the population based on composition of DS2500, subject to the margins of error in Table 6.

While some of the categories are poorly represented in the sample (and hence require larger proportional confidence intervals), it is important to note that this research concerns a knowledge-based approach to classification, and is focused primarily on such categories as video and software. With regards to DS2500 we were aiming to learn what kind of items are posted as torrents, and incorporate a generalised version of this knowledge into the bigger classification framework.

Apart from acquiring domain knowledge from DS2500 we also used it for tuning the Toran prototype and compared its performance against the MVL system. Once we achieved a considerable improvement over MVL, we went on to test Toran on other data sets. When evaluating predictions on DS2500 we have to assume the

human classifications as the actual state of the items, because the ultimate true state is unknown to us.

Full results of Toran and MVL versus human approximation of the item classifications are given in Sections 6.1 and 6.3 and the complete data set is available in Appendix Section D.1.

*b) DS480: Validation Set*

DS480 is not a part of DS2500 and consists of 479 items collected from a live stream of recently discovered torrents, but is similar in that its items are not verified and we only have human classifications to take as the approximation of the true item state. We did not incorporate any knowledge from this set into the Toran configuration to ensure that it provided us with a clear idea of the method's performance.

MVL and Toran are compared on this set against human classifications in Chapter 6 and the complete data set is available in Appendix Section D.2.

*c) DS120: Test Set*

DS120 contains 121 items collected, similarly to DS480, from a live stream of recently discovered torrents. However, in contrast to DS480, in this set we were able to verify contents of all files. It is different from DS2500 and DS480 in that it allows us to evaluate performance of human classifiers as well as automated classifier agents.

We recognise that the size of DS120 is lower than preferable to provide a very reliable assessment of accuracy. However, obtaining a fully verified set even of this size was a major challenge, since to verify the contents of a torrent requires us to fully download and inspect/play it in its entirety. Moreover, there are a number of practical challenges that limited our ability to download and verify items. For example:

- Many torrents fail to start downloading or become unavailable prematurely, even if discovered recently.
- Torrents often maintain a low or unreliable download speed while taking up space in the download queue.
- When torrents are downloaded, precautions must be made to avoid malware while verifying content.

The sheer volume of traffic makes real verification a remarkably difficult task. For example, the data contained in torrents from DS120, DS480 and DS2500 alone amount to 4.6 terabytes, which is over 250 hours of continuous download on a full-speed average Internet connection (Ofcom Communications 2013).

Also, due to the nature of file sharing systems, the full speed download is not guaranteed; many torrents quickly become unavailable and in many cases full verification is impossible.

Figure 4 shows the actual medium class distribution in DS120.

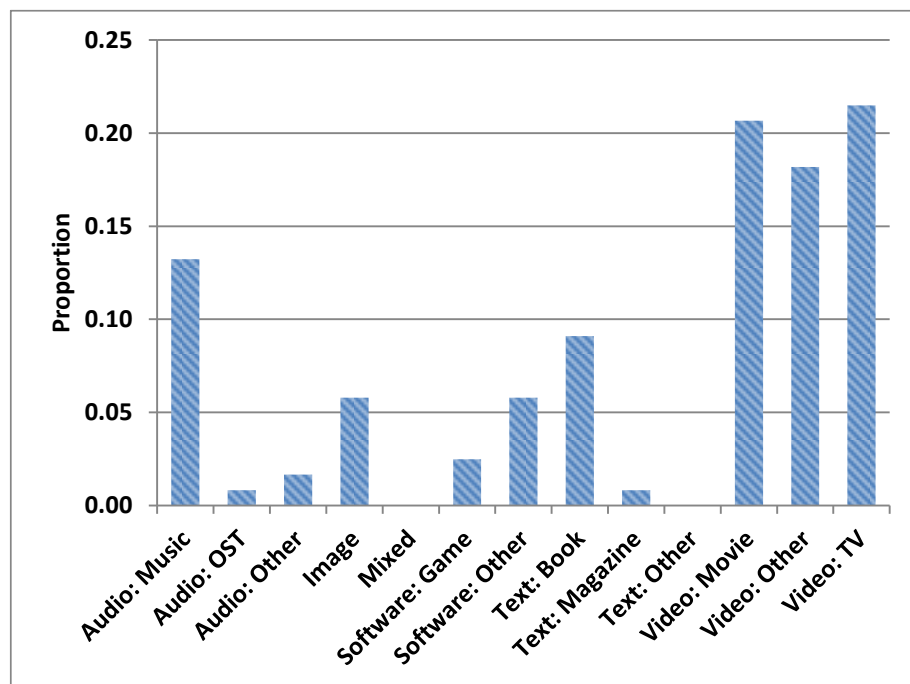

Figure 4: Verified Composition of DS120

We compare humans, MVL and Toran predictions to the verified classifications, estimate their accuracy on actual data and provide a confidence interval in Chapter 6. The complete data set is available in appendix Section D.3.

*d) Fakes and Malware Data Set (DSFM): Test Set*

One of our core research objectives was to design a coherent framework which can improve detection of high risk files such as *fakes* and *malware*. We consider a torrent to be a *fake* if it was created to mislead the public rather than share its supposed original content. For example, the torrent from Figure 1 contains the name of a TV series and some information about the video quality and encoding, so it clearly attempts to communicate that the torrent contains a video file. Yet, if the torrent actually contains a malicious executable file, which in this particular case is given away by the '.exe' file extension, it is then a fake. Note that the same name can be used by a fake and a legitimate torrent, for example, 'Gone Girl (2014) HDRIP AVI' may be a broken video in the former case and the actual movie in the latter. Torrents with encrypted names that aim to avoid automatic detection are not considered fake in this context. Another interesting case are items named like 'San Andreas AVI'. Such a torrent may contain the movie 'San Andreas' (2015), or a holiday video made by somebody who spent a weekend in San Andreas and wanted to share it with their friends. In both cases it would not be a fake, because it does not claim to be (or not be) the movie, specifically.

Some torrents also contain *malware* e.g. malicious executable code of undeclared purpose. Most commonly, malware is correlated with fakes but, in theory, any piece of software can be infected with malware that piggybacks on the actual advertised functionality of the application.

We attempted to establish whether humans, who are specifically instructed to be alert and suspicious, are able to identify fakes. We then compared their results to Toran's performance.

We also gained some insight into how humans perform this task. The reasoning provided by human participants suggests that, apart from intuition, humans evaluate the risk of a fake by checking whether:

- they see any unrecognised keywords in the file name
- the file size is lower than expected
- the movie was released at the moment of classification, and whether it was released in a digital format specifically

We downloaded and verified 100 items that looked like movie torrents from a live feed of items recently discovered by the MovieLabs torrent tracker. None of these items appear in any of our other data sets.

We presented the human participants with a choice of three options per item:

- *Fake* – item is not the movie it claims to be
- *Malware* – not only the item is a fake, but it also is (contains) malware
- *None* – the item is actually the movie it claims to be

<b>Class</b>	<b>Count</b>
Fake and Malware	23
Fake not Malware	23
None	54
<b>Total</b>	<b>100</b>

Table 7: Fakes and Malware Distribution in DSFM

Table 7 shows class distribution in DSFM. While again we would have preferred a larger test set, it provides grounds for establishing the feasibility of our method.

The complete data set, including the verdicts given by individual human participants, is available in appendix Section D.4. Comparison between human and Toran’s performance are given in Chapter 6.

e) *Bitsnoop Data Set (DSBS): Test Set*

A classification system that is supposed to be autonomous should be tested in a live environment outside of the lab conditions under which it was developed. For such a test we gathered, over the course of several weeks, torrents from a live feed of a popular tracker (BitSnoop 2015) that claims to index more than 24 million torrents from more than 350 other. BitSnoop seems to focus on items that are music, games, software applications, books, movies and TV programmes. This means that many categories that are available to Toran for selection are actually absent from the set of true categories, leading to potentially higher error rate and increased number of false positives. It also means that our prior expectations about the distribution of medium across the item collection is only partially suitable for this data set.

<b>Bitsnoop Category</b>	<b>Toran Medium</b>
Audio	Audio
Audio » Lossless	Audio: Music
Audio » Music	Audio: Music
Games	Software: Game
Games » Mac	Software: Game
Games » PC	Software: Game
Games » Playstation	Software: Game
Games » PSP	Software: Game
Games » X-Box	Software: Game
Other	N/A
Other » Comics	Text: Book
Other » Ebooks	Text: Book
Other » Pictures	Image
Software	Software: Other
Software » Mac	Software: Other
Software » Mobile	Software: Other
Software » PC	Software: Other
Software » Unix	Software: Other
Video	Video
Video » Anime	Video: TV
Video » Movies	Video: Movie
Video » Music	Video: Other
Video » TV	Video: TV

Table 8: Categories in the BitSnoop Data Set and Mapping to Toran Taxonomy



Table 8 demonstrates the categories found in the BitSnoop data set and how we map them into our own taxonomy.

We do not know exactly how BitSnoop populate their database and what is the classification procedure (if any), but we do know that it is quite different from the one followed by MovieLabs. Our attempts to contact BitSnoop for clarification were ignored, so we consider this experiment at face value. Crucially, some items at BitSnoop are misclassified or only partially classified.

```
VA - Finding Neverland (The Album) [2015] [OST] [CDRiP] [MP3-VBR] [GLODLS]
```

Figure 5: Example of a Partially Classified Item in BitSnoop Data Set

For example, the torrent in Figure 5 of size 100MB is listed at BitSnoop as “Audio”; however, we can clearly see that it is, in fact, “Audio: Soundtrack” for the movie ‘Finding Neverland’ (2004).

```
Дядя Деда / Uncle Grandpa [35 серий из ?] (2013) SATrip от New-Team | D
```

Figure 6: Example of a Misclassified Item in BitSnoop Data Set

Another example of a misclassified item is presented in Figure 6, which is 5,680MB and is listed as “Video: Movie”, while it actually is a “Video: TV”.

In order to provide a coherent comparison, we attempted to obtain MVL classifications for items collected from BitSnoop. However, since MVL does not index all of BitSnoop items, we had to limit the data set only to include torrents that had a full classification provided by BitSnoop while at the same time indexed by MVL.

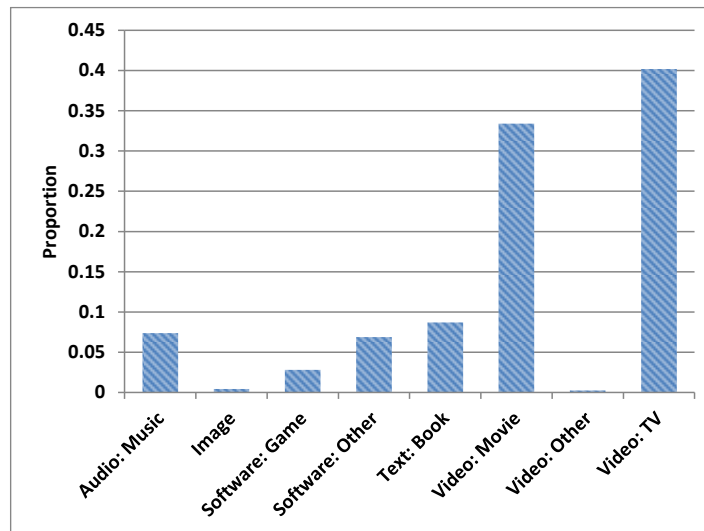

Figure 7: Composition of DSBS According to BitSnoop

The final size of DSBS is 45,209 items. Figure 7 shows the class distribution in DSBS according to full categories translated from classifications provided by BitSnoop. The complete data set is available in Appendix Section D.5. The results and comparison between Toran and MVL performance are given in Section 6.4.

## 2.6. Classification and Evaluation Methods

This thesis is ultimately concerned with classification of generic ill-formed media items in order to process them into an organised data structure. Automated classification was pioneered as text classification, also called text categorisation (TC), which is an important area of research dating back more than half a century (Maron 1961; Boroko & Bernick 1963). The most common uses for TC currently include automatic indexing or tagging, multimedia categorisation, author identification, language identification, text filtering (e.g. document relevance or spam filters), word sense disambiguation etc. TC essentially relies on breaking up a document into words, phrases or fragments (normally called *terms*) and working out the document category based on the term it contains. A torrent name is a text string (i.e. 'document') and consists of keywords and titles (i.e. 'terms'), which is why we consider TC relevant to our work.

A classical approach to classification employs knowledge engineering (Studer et al. 1998) practices such that a domain expert defines a set of membership rules for each category or class, and the items that satisfy the criteria are assigned to the relevant category automatically. While allowing for accurate definition and adjustment of conditions to achieve very good results (Hayes et al. 1990), such systems have a major drawback in the form of *knowledge acquisition bottleneck*, meaning that every amendment to the classification scheme requires intervention of a domain expert to define or fix the membership rules.

In the past 20 years the newly emerged field of machine learning (Mitchell 1996) became increasingly focused on automated TC (Sebastiani 2002). The main idea behind this approach is to use sets of pre-classified documents called *training sets*, to allow a machine learning (ML) algorithm to devise a strategy for categorising the documents in such a way that they logically fall into defined categories, and then extrapolate this strategy and apply it for future classification.

Ultimately, a categorisation decision can be either Boolean (also 'hard') or ranked. The former specifies whether an item is assigned to a category or not, while the latter computes the rank of each possible assignment. Boolean classification is widely used in automated systems, while ranked systems are extremely useful for providing viable decision support in terms of categorisation options to a human operator who makes the final classification decision.

One of the benefits of ML over KE in classification is the ability to devise classification rules automatically with little or no knowledge specifically encoded into the process, based simply on correlations within the training set. However, this also is a drawback because it provides no coherent way of recognising the difference between correlation and causation, and requires a sufficiently large set of verified training data.

### 2.6.1. Brief Introduction to Document Classification

A typical classification algorithm has to transform a document into a compact representation of its content before it can interpret it. A popular way to model a document is to process it into a vector of term weights (Salton et al. 1975). Depending on the algorithm, a term can be defined as either a word or a phrase. Furthermore, a phrase can be motivated either syntactically (Lewis 1992) (i.e. according to the language grammar), or statistically (Caropreso et al. 2001) (i.e. as a set or a sequence of words which form patterns statistically significant in the document). There are many ways to calculate the weights of each term, as long as they accurately denote the significance of the term within the document.

The *term frequency / inverse document frequency* (TF-IDF) (Salton 1989) is a classical measure used for specifying word weights. According to this technique, each document  $d_j$  is defined by a vector of TF-IDF weights for the top  $K$  most significant keywords in the item. For document classification,  $K$  was found to be optimal around 100 (Pazzani et al. 1996; Balabanović 1997). Each such weight for keyword  $k_i$  is defined as a product of *term frequency* of  $k_i$  in  $d_j$  and *inverse document frequency* for  $k_i$ :

$$w_i = TF_{i,j} \times IDF_i \quad (1)$$

$TF_{i,j}$  is the measure of relevance of the keyword in the document, while  $IDF_i$  is inversely proportional to relevance of the keyword to the whole document collection. When documents are compared, words frequently found in the collection as a whole are considered to be less important than the rarer terms. Normalisation is then performed to remove bias towards longer documents.

Before calculating the term weights, in most cases *function words* are removed (e.g. conjunctions, prepositions, articles etc). Then *stemming* (Lovins 1968; Porter 1980) is applied, which reduces all words to their morphological roots e.g. reducing

'arguing', 'argue', 'argus', 'argued' and 'argues' to the stem 'argu', which itself is not a vocabulary word. Sometimes, however, it is more sensible to leave the text unchanged before performing classification, for example, to establish authorship of a disputed document. In such case a particular importance may lie with the frequency of words e.g. 'because' or 'though' used by the author.

The term *categorisation status value* (CSV) is used in ranked inductive classifiers and is defined as a number between 0 and 1. It represents a degree to which a document belongs to a category, and which is returned by the CSV function. The CSV function can be defined in a number of ways, but among the most popular is the naïve Bayes approach. In case of Boolean categorisation, the CSV function can return a *true* or *false* value. Alternatively, it may be derived from a ranked function by using a threshold to automatically make a decision whether the rank implies *true* or *false*, which is similar to how a human expert might reason. The threshold can be defined either *analytically* or *statistically*. The former includes probability membership estimations and decision-theoretic measures (e.g. utility, or the benefit). The latter involves testing different values of the threshold on a validation set in order to optimise it. This approach is called *thresholding* and includes two additional variants: *proportional thresholding* which is based on the assumption that the number of documents assigned to a category from the training set is proportional to that of the test set; and *fixed thresholding* which adjusts the threshold in a way that every document is assigned to a fixed number of categories.

## 2.6.2. Naïve Bayesian Classifiers

While Bayes' theorem and Bayesian networks are covered in Chapter 3, this subsection briefly introduces the context for its use with regards to this thesis. Capturing the essential uncertainty about an item belonging to a particular category is possible in the framework of probabilistic classification, such as with a Bayesian classifier.

In this case the CSV function can be defined as:

$$CSV(d) = P(c|\vec{d}) \quad (2)$$

where it returns a probability  $P(c|\vec{d})$  that an arbitrary item  $d$ , which is represented by a vector of weights  $\vec{d}$  belongs to a particular category  $c$ . Probability  $P(c|\vec{d})$  also depends on related probabilities  $P(c)$ , which is the probability that an arbitrarily selected item belongs to the category  $c$ ;  $P(\vec{d})$ , which is the probability that an arbitrarily selected item is described by the vector of weights  $\vec{d}$ ; and  $P(\vec{d}|c)$ , which is the probability that an arbitrary item from category  $c$  is described by the vector  $\vec{d}$ , according to:

$$P(c|\vec{d}) = \frac{P(c) P(\vec{d}|c)}{P(\vec{d})} \quad (3)$$

Calculating  $P(\vec{d}|c)$ , however, is problematic due to the large number of possible terms and their weights.

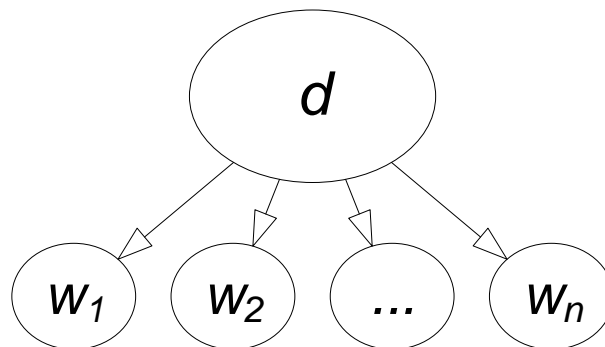

Figure 8: Naïve Bayes Illustration

One of the ways of resolving this problem is by using the principle of naïve Bayes (Duda & Hart 1973; Lewis 1998), which is illustrated in Figure 8 where an item  $d$  is described by a vector  $\vec{d} = \{w_1, w_2, \dots, w_n\}$  where  $w_1$  through  $w_n$  are term weights and  $n$  is the total number of terms in the document vector. In fact, most Bayesian classifiers or recommender systems are ultimately based on the idea of a naïve Bayesian learning approach that assumes event independence i.e. that attributes (e.g. terms) appear in a document completely independently. Although this is logically wrong, such classifiers were proven to be very effective (Langley et al. 1992; Sahami 1996; Friedman 1997; Friedman et al. 1997), especially for text-based classification. Once the independence is assumed, it becomes possible to link terms to categories directly:

$$P(\vec{d}|c) = \prod_{i=1}^n P(w_i|c) \quad (4)$$

where probability  $P(\vec{d}|c)$  is the product of probabilities of individual weights observed within the category  $c$ .

Considering the example torrent from Figure 1 and its ‘terms’ given in Table 1, we may encode the item according to the semantic type of its terms. For simplicity, we may express this as  $\{TV\ title, season\ and\ episode, video\ information, executable\ extension\}$ . Each of these terms would have a particular probability of appearing for a given category, such as, for example, ‘TV title’ and ‘season and episode’ are very likely for items in the “Video: TV” category and unlikely for other categories, while ‘executable extension’ is likely for “Software” and unlikely for others.

<b>Term</b>	<b>Weight for “Video: TV”</b>	<b>Weight for “Software”</b>
TV title	0.90	0.001
Season and episode	0.85	0.001
Video information	0.90	0.001
Executable extension	0.0001	0.9

Table 9: Term Weights Illustration for Example in Table 1

We calculate  $P(\vec{d}|c)$  for each category according to Equation 4 and compare them:

$$\begin{aligned} P(\vec{d}|c = \text{"Video: TV"}) &= 0.9 \times 0.85 \times 0.9 \times 0.0001 \approx 2.52 \times 10^{-5} \\ P(\vec{d}|c = \text{"Software"}) &= 0.001 \times 0.001 \times 0.001 \times 0.9 \approx 9.00 \times 10^{-7} \end{aligned} \tag{5}$$

where “Video: TV” ends up being the more likely category.

As we will explain in Chapter 3 the Toran system is an extension of a Bayesian classifier, but with a richer causal structure and without many of the unrealistic term independence assumptions (the necessary model is a Bayesian network). The necessary Bayesian inference calculations required are much more complex than those of a naïve Bayesian classifier, but can be performed using Bayesian network tools.

### 2.6.3. Terms of Accuracy

Multiple methods exist to measure the quality of classification results that can be assessed either analytically or experimentally. The analytical evaluation normally implies a proof that a system is complete and correct, which may be difficult to define and prove. In the case of multiple and subjective categories, it is argued in (Sebastiani 2002) that the problem cannot be properly formalised. Hence, evaluation is usually performed experimentally, often with an accent on effectiveness of the system (i.e. the degree of correctness of the classifier) rather than its efficiency.

Binary (e.g. Boolean) classification results are often measured in terms of *true positives* (TP), *true negatives* (TN), *false positives* (FP) and *false negatives* (FN). Table 10 illustrates these terms of accuracy given possible combinations of predicted and actual states.



		Actual State	
		False	True
Predicted State	False	TN	FN
	True	FP	TP

Table 10: Terms of Accuracy

Among the most popular metrics are precision  $\pi$  and recall  $\rho$  (also known as *sensitivity*), which are classical measures in IR, and can be naturally applied to classification.

In general, *precision*  $\pi$  of a system (also called *positive predictive value*) on a given set of items is equal to the proportion of correct instances of classification out of the whole set of positive decisions performed:

$$\pi = \frac{TP}{TP + FP}, 0 \leq \pi \leq 1 \quad (6)$$

*Recall*  $\rho$ , also called *sensitivity*, is the number of correct positive classifications out of the number of actual positives:

$$\rho = \frac{TP}{TP + FN}, 0 \leq \rho \leq 1 \quad (7)$$

Two different variations for calculating recall and precision are possible: *macroaveraging* where individual category values are calculated and then an overall category average is taken; or *microaveraging* where all classifications from all categories are averaged.

*Specificity*  $\gamma$  is a measure of how well a system is able to detect negative results, which is similar to *recall/sensitivity*, which is concerned with how well a system is able to detect positive results.

$$\gamma = \frac{TN}{TN + FP}, 0 \leq \gamma \leq 1 \quad (8)$$

The above metrics are combined by the *f-measure* (also  $F_1$  score), which is the harmonic mean of precision and recall and is more tolerant to outliers than other means:

$$F_1 = 2 \times \frac{\pi \times \rho}{\pi + \rho}, 0 \leq F_1 \leq 1 \quad (9)$$

The  $F_\beta$  variant provides an ability to weight *precision* or *recall* higher than the other by adjusting the value of  $\beta$ :

$$F_\beta = (1 + \beta^2) \times \frac{\pi \times \rho}{\beta^2 \times \pi + \rho}, 0 \leq F_\beta \leq 1 \quad (10)$$

In essence, *recall* is  $\beta$  times more important than *precision*.

The above measures were criticised in (Powers 2011) for not using the *false negatives* and hence being susceptible to manipulation by biased predictions. *Matthews correlation coefficient* (MCC) (Matthews 1975) is a metric which utilises all results of the classification and is generally considered to be more balanced and suitable even if classes vary highly in size.

$$MCC = \frac{TP \times TN - FP \times FN}{\sqrt{(TP + FP)(TP + FN)(TN + FP)(TN + FN)}}, -1 \leq MCC \leq 1 \quad (11)$$

MCC returns a value from -1 to 1, where 1 means perfectly correct classification, 0 is neither better nor worse than random and -1 is complete disagreement with the true state.

An additional evaluation criteria is *accuracy*  $\alpha$ , which measures how well a binary classifier categorises all items, implying that not pairing  $d$  to  $c$  requires a specific choice not to; and is defined as:

$$\alpha = \frac{TP + TN}{TP + FP + TN + FN}, 0 \leq \alpha \leq 1 \quad (12)$$

## 2.6.4. Probabilistic Prediction Metrics

Probabilistic predictions are made in the form of a prediction vector, which is composed of probabilities assigned to each of the possible classes, such that all of them add up to 1. We introduce here several scoring rules, which we apply to our method in Chapter 5.

We define the actual state of an item as:

$$S^R = \{S_{c_1}^R, \dots, S_{c_k}^R\}, \quad \begin{array}{l} c \in C \\ k = |C| \end{array} \quad (13)$$

where  $S^R$  is a set of weights assigned to each state  $c$  of the item's actual classification,  $C$  is the set of all possible states, and  $k$  is the size of  $C$ . To illustrate, let there be 4 possible states: "Video", "Audio", "Software" and "Text". An item that is, in fact, a "Video", would be encoded as a vector by assigning a value of 1 to "Video" and values of 0 to all other categories:

$$S^{R1} = \begin{cases} P(S = Video) & = 1.0 \\ P(S = Audio) & = 0.0 \\ P(S = Software) & = 0.0 \\ P(S = Text) & = 0.0 \end{cases} \quad (14)$$

A prediction vector  $S^P$  is the same as  $S^R$ , and  $S_c^P$  denotes the predicted weight of category  $c$  in the item's classification. To illustrate how accuracy is compared let  $S^{P1}$ ,  $S^{P2}$  and  $S^{P3}$  be different predictions expressed by vectors:

$$\begin{aligned} S^{P1} &= \begin{cases} P(S = Video) & = 0.75 \\ P(S = Audio) & = 0.05 \\ P(S = Software) & = 0.10 \\ P(S = Text) & = 0.10 \end{cases} \\ S^{P2} &= \begin{cases} P(S = Video) & = 0.25 \\ P(S = Audio) & = 0.25 \\ P(S = Software) & = 0.25 \\ P(S = Text) & = 0.25 \end{cases} \\ S^{P3} &= \begin{cases} P(S = Video) & = 0.25 \\ P(S = Audio) & = 0.65 \\ P(S = Software) & = 0.05 \\ P(S = Text) & = 0.05 \end{cases} \end{aligned} \quad (15)$$

**Brier score** ( $BS$ ) was introduced in (Brier 1950) and is one of the most popular metrics. It is equal to the sum of squared differences between predicted and actual probability values for each class or state:

$$BS(S^R, S^P) = \sum_{c \in C} (S_c^P - S_c^R)^2, \quad 0 \leq BS \leq 2 \quad (16)$$

Where  $BS(S^R, S^P)$  is the Brier score, calculated for a pair of probability vectors,  $C$  is the set of possible classes,  $c$  is a particular class such that  $c \in C$ ,  $S_c^R$  is the true state proportion of the item within category  $c$  (e.g.  $S_{video}^R = 1$  and  $S_{audio}^R = 0$ ) and  $S_c^P$  is the predicted proportion of the item within  $c$ . Higher values of  $BS$  correspond to worse predictions, because it is an error metric, while  $BS = 0$  is indicative of a perfect prediction.

$$\begin{aligned} BS(S^R, S^{P1}) &= \text{sum} \left\{ \begin{array}{l} (0.75 - 1)^2 \\ (0.05 - 0)^2 \\ (0.10 - 0)^2 \\ (0.10 - 0)^2 \end{array} \right\} \approx 0.02 \\ BS(S^R, S^{P2}) &= \text{sum} \left\{ \begin{array}{l} (0.25 - 1)^2 \\ (0.25 - 0)^2 \\ (0.25 - 0)^2 \\ (0.25 - 0)^2 \end{array} \right\} = 0.75 \\ BS(S^R, S^{P3}) &= \text{sum} \left\{ \begin{array}{l} (0.25 - 1)^2 \\ (0.65 - 0)^2 \\ (0.05 - 0)^2 \\ (0.05 - 0)^2 \end{array} \right\} = 0.99 \end{aligned} \quad (17)$$

Equation 17 illustrates how  $BS$  is calculated for different prediction vectors from example above. Note that average Brier score over the whole data set is equal to *mean squared error*, and when there are only 2 possible classes, i.e. classification is binary,  $BS$  is also equal to *error rate*.

**Absolute error** ( $AE$ ) (Armstrong 2001; Hyndman & Koehler 2006) considers only the absolute difference between the prediction and the actual state. When the true state is a single category,  $AE$  is equal to the difference between 1 and the predicted

probability of the item to belong to the correct category, hence 0 denotes a perfect match while 1 means a complete mismatch.

$$AE(S^R, S^P) = 1 - P(S_{c_A}^P = S_{c_A}^R), \quad 0 \leq AE \leq 1 \quad (18)$$

where  $c_A$  denotes the actual category of the item. Equation 19 shows  $AE$  calculated for all three predictions from the example above. Note that  $AE$  does not discriminate between wrong predictions that spread the probability over multiple classes, and strong erroneous predictions of a single class.

$$\begin{aligned} AE(S^R, S^{P1}) &= 1 - 0.75 = 0.25 \\ AE(S^R, S^{P2}) &= 1 - 0.25 = 0.75 \\ AE(S^R, S^{P3}) &= 1 - 0.25 = 0.75 \end{aligned} \quad (19)$$

Average  $AE$  over a set of multiple items is called *mean average (percentage) error (MAE)*. Over the set of examples in Equation 19  $MAE$  is 0.58.

**Quadratic scoring rule (QS)** (Brier 1950) is defined as the sum of squares of each predicted class subtracted from twice the correct portion of prediction  $S_{c_A}^P$ :

$$QS(S^R, S^P) = 2 \times S_{c_A}^P - \sum_{c \in C} (S_c^P)^2, \quad -1 \leq QS \leq 1 \quad (20)$$

We can apply this metric to the examples above and arrive at the set of results:

$$\begin{aligned} QS(S^R, S^{P1}) &= 2 \times 0.75 - (0.75^2 + 0.05^2 + 0.1^2 + 0.1^2) \approx 1.5 - 0.58 \approx 0.92 \\ QS(S^R, S^{P2}) &= 2 \times 0.25 - (0.25^2 + 0.25^2 + 0.25^2 + 0.25^2) = 0.5 - 0.25 = 0.25 \\ QS(S^R, S^{P3}) &= 2 \times 0.25 - (0.25^2 + 0.65^2 + 0.05^2 + 0.05^2) = 0.5 - 0.49 = 0.01 \end{aligned} \quad (21)$$

Unlike  $BS$  or  $AE$ , a higher  $QS$  value is indicative of a better prediction.

*Spherical scoring* rule ( $SS$ ) (Roby 1964) is defined as the correct portion of prediction  $S_{c_A}^P$  over the magnitude of the prediction vector  $\|S^P\|$ :

$$SS(S^R, S^P) = \frac{S_{c_A}^P}{\|S^P\|} = \frac{S_{c_A}^P}{\sqrt{\sum_{c \in C} (S_c^P)^2}}, \quad 0 \leq SS \leq 1 \quad (22)$$

Applied to examples above,

$$\begin{aligned} SS(S^R, S^{P1}) &= \frac{0.75}{\sqrt{0.585}} \approx 0.98 \\ SS(S^R, S^{P2}) &= \frac{0.25}{\sqrt{0.25}} = 0.50 \\ SS(S^R, S^{P3}) &= \frac{0.25}{\sqrt{0.49}} \approx 0.36 \end{aligned} \quad (23)$$

Similarly to  $QS$ , a higher  $SS$  means better prediction. Note how  $BS$ ,  $QS$  and  $SS$  are sensitive to the confidence of the wrong predictions, issuing a higher penalty to prediction vectors with erroneous predictions of bigger magnitude.

*Logarithmic scoring* ( $LS$ ) (Toda 1963; Shuford et al. 1966) rule is defined as a logarithm of the correct portion of the prediction  $S_{c_A}^P$  to an arbitrary base  $n$ :

$$LS(S^R, S^P) = \log_n(S_{c_A}^P), \quad \begin{array}{l} -\infty \leq LS \leq 0 \\ n > 0 \end{array} \quad (24)$$

Applied to examples above,

$$\begin{aligned} LS(S^R, S^{P1}) &= \log(0.75) \approx -0.13 \\ LS(S^R, S^{P2}) &= \log(0.25) \approx -0.60 \\ LS(S^R, S^{P3}) &= \log(0.25) \approx -0.60 \end{aligned} \quad (25)$$

Higher  $LS$  also expresses better prediction, however there are several differences from the metrics above:

- The worst prediction will get a score of  $-\infty$  which means that it may be impossible to calculate average  $LS$  for a sample

- *LS* only accounts for the correct portion of the prediction, completely discarding any information about how the incorrect portion of the prediction was distributed among classes
- *LS* is able to return a score even when the actual state is a mixture of classes (e.g. a musical video may be classed as 50% music and 50% video), in which case it is extended according as follows:

$$LS(S^R, S^P) = \sum_{c \in \mathcal{C}} P(S_c^R) \log(P(S_c^R = S_c^P)) \quad (26)$$

*Pearson product-moment correlation coefficient (PCC)* (Bravais 1846; Pearson 1896) can be used in cases when the true state of the item is also spread across multiple classes. *PCC* is defined as a cross product of two vectors  $\bar{v}_1$  and  $\bar{v}_2$  divided by a product of their magnitudes:

$$PCC(\bar{v}_1, \bar{v}_2) = \frac{\bar{v}_1 \times \bar{v}_2}{\|\bar{v}_1\| \times \|\bar{v}_2\|}, \quad -1 \leq PCC \leq 1 \quad (27)$$

Where  $PCC = 0$  denotes complete absence of correlation,  $PCC = 1$  is complete positive correlation and  $PCC = -1$  is total negative correlation. It is possible to express a prediction and the true state as vectors, so this formula is also applicable to estimating prediction accuracy. Similarly to *LS*, *PCC* can handle situations where the true state itself is a mixture of categories.

Imagine a musical video represented by the following true state distribution:

$$S^R = \begin{cases} P(S = Video) & = 2/3 \\ P(S = Audio) & = 1/3 \\ P(S = Software) & = 0 \\ P(S = Text) & = 0 \end{cases} \quad (28)$$

An effectively uncertain true state makes Brier, quadratic and spherical scores inappropriate. On the other hand, translating both true state and predicted state into corresponding vectors  $S^R\{2/3, 1/3, 0, 0\}$  and  $S^P\{0.75, 0.05, 0.1, 0.1\}$  allows using

*cosine similarity* metric  $CS$  which is equal in this case to the Pearson correlation coefficient:

$$CS(S^R, S^P) = \frac{S^R \times S^P}{\|S^R\| \times \|S^P\|} \approx 0.91 \quad (29)$$

The metric  $CS$  is defined in the range from -1 to 1, where a complete mismatch results in -1, value of 0 denotes random chance and 1 means a complete match.

### 2.6.5. Applying Accuracy Metrics in the Project

In this section we assess the suitability of the accuracy metrics described above to assess predictions made by a probabilistic system such as Toran. Many commonly used accuracy metrics have their drawbacks, such as high sensitivity to outliers, ability to return undefined or infinite values, inability to properly handle non-binary outcomes that are not equally different from one another, etc.; and are summarised in (Hyndman & Koehler 2006; Constantinou & Fenton 2012).

We compare performance of these metrics on a few synthetic prediction examples, each defined as a probability vector in Table 11.



Category	Examples								
	1	2	3	4	5	6	7	8	9
Audio: Music	0.00	0.00	0.00	0.03	0.05	0.00	0.08	0.33	0.00
Audio: OST	0.00	0.00	0.00	0.03	0.05	0.00	0.08	0.00	0.00
Audio: Other	0.00	0.00	0.00	0.03	0.05	0.00	0.08	0.00	0.00
Image	0.00	0.00	0.00	0.03	0.05	0.00	0.08	0.00	0.00
Mixed	0.00	0.00	0.00	0.03	0.05	0.00	0.08	0.00	0.00
Software: Game	0.00	0.00	0.00	0.03	0.05	0.00	0.08	0.00	0.00
Software: Other	0.00	0.00	0.33	0.03	0.05	0.00	0.08	0.33	1.00
Text: Book	0.00	0.00	0.00	0.03	0.05	0.00	0.08	0.33	0.00
Text: Magazine	0.00	0.00	0.00	0.03	0.05	0.00	0.08	0.00	0.00
Text: Other	0.00	0.00	0.00	0.03	0.05	0.00	0.08	0.00	0.00
Video: Movie	1.00	0.67	0.67	0.36	0.38	0.33	0.08	0.00	0.00
Video: Other	0.00	0.33	0.00	0.36	0.05	0.33	0.08	0.00	0.00
Video: TV	0.00	0.00	0.00	0.03	0.05	0.33	0.08	0.00	0.00

Table 11: Example Predictions for Item that is "Video: Movie"

These predictions could be derived, for example, from a combination of 3 votes according to Figure 9. We expect that accuracy metrics rank these predictions in the order they are presented in the Table 11 (except for #8 and #9 for reasons discussed below).

1	Video: Movie Video: Movie Video: Movie	2	Video: Movie Video: Movie Video: Other	3	Video: Movie Video: Movie Software: Other
4	Video: Movie Video: Other Unknown	5	Video: Movie Unknown Unknown	6	Video Video Video
7	Unknown Unknown Unknown	8	Audio: Music Software: Other Text: Book	9	Software: Other Software: Other Software: Other

Figure 9: Possible Votes that Produce Distributions in Table 11

Example #1 is a simple case of a unanimously correct classification. In #2 and #3 there are 2 out of 3 correct votes, but the crucial difference is that the third vote in former case is a related sub-category, while in the latter case it is an unrelated

category. Compared to example #3, in the example #4 one of the votes is 'Unknown', while one correct vote is replaced by a vote for a related video category. Example #5 features two 'Unknown' votes and one correct vote, making the collective prediction more uncertain. We prefer to rank example #6 lower than #5 because it does not contain a certain vote for a correct category at all and rather has three weak votes for the video super-category in general. It is possible however that #4, #5, #6 and #7 receive similar scores depending on how "Unknown" is interpreted. For example, if an agent uses a prior distribution for "Unknown" cases, and in that distribution chance of "Video: Other" is 0.33, then #4 is virtually the same as #5. This is why we reason about the examples in this section assuming "Unknown" represents ignorance and an equal distribution across categories. However, when performance of actual agents is confirmed further in the thesis, they are allowed to use their prior category distributions for the "Unknown" interpretation. In this case the requirement is that each of the examples #3-7 receives either the same or worse score than the previous example.

Example #7 is completely uncertain, while #8 is a range of wrong answers. Prediction #9 is a strong wrong prediction in a particular sub-category, which is marginally worse than #8 because the latter at least shows some uncertainty about the category, while #9 is completely confident and wrong. It may be argued that there could be no difference between #8 and #9 or that it is not necessary to distinguish these examples for assessing the ability to make correct predictions. However, the distinction may still be important for analysing the nature of incorrect predictions.

We apply metrics, such as *absolute error AE*, *quadratic score QS*, *Brier score BS*, *logarithmic score LS* and *spherical score SS*, to the examples from Table 11, and the calculated scores can be found in Table 12.

Ex.	<i>AE</i>	<i>BS</i>	<i>LS</i>	<i>QS</i>	<i>SS</i>
1	0.00	0.00	0.00	1.00	1.00
2	0.33	0.22	-0.18	0.78	0.89
3	0.33	0.22	-0.18	0.78	0.89
4	0.64	0.55	-0.44	0.45	0.70
5	0.62	0.41	-0.41	0.59	0.91
6	0.67	0.67	-0.48	0.33	0.58
7	0.92	0.92	-1.11	0.08	0.28
8	1.00	1.33	$-\infty$	-0.33	0.00
9	1.00	2.00	$-\infty$	-1.00	0.00

Table 12: Accuracy Metrics Calculated for Examples from Table 11

While we do observe the general expected trend of best score in the top and a gradual transition to the worst case in the bottom for all of the metrics, they turn out to be inappropriate for assessing predictions where sub-categories are not equally distant from each other. This is demonstrated in Table 12. Notably, examples #2 and #3 should result in a different score, while example #5 should score less than or equal to #4. As suggested in (Constantinou & Fenton 2012) most metrics normally used under similar conditions do not respect the fact that labels can be related, which raises the question of the evaluation quality itself. They give an example of predicting football match results where possible outcomes are ‘home win’, ‘draw’ or ‘away win’, and all of the metrics covered consider these options to be equally unrelated. However, Constantinou and Fenton argue that ‘home win’ is closer to ‘draw’ than to ‘away win’, and vice versa, which means that most studies fail to recognise the importance of possible relations between category labels and subsequently can lead to wrong evaluation results.

We conclude that none of the above classical metrics are fully appropriate for our study because they fail to rank predictions made within the correct super-category higher than those in a completely different super-category. The logarithmic scoring rule, in addition to this, returns a negative infinity as the worst score, which

hampers its suitability for average performance assessment. We discuss a possible solution to address this issue in chapter Section 5.5.

## 2.7. String Comparison

One of the aims of this research is to develop a framework which combines a Bayesian approach to classification with an external knowledge source in a way that the former can perform autonomously and adequately while the latter requires manual maintenance but improves the final results delivered by the method. Apart from classifying media items by analysing various file type signatures in the file name, a major challenge lies in the attempt to individually identify media files as particular movie titles and detect whether there are risks associated with these titles at the given time. To accomplish this task, we use a collection of movie, TV series and video game titles as specified in Section 2.4. There are several reasons for attempting to detect a title in the name string:

- a) There may be no information about medium present in the file name, in which case it may be sensible to assume the item is a movie, given its file size and the fact a title was detected.
- b) Some titles (e.g. movies prior to their digital release) can be associated with higher risks of fakes or malware, and the fact of detecting such a title must impact the medium type of the prediction.
- c) Porn detection can also be improved for files which have no regular porn markers such as signatures, actors or studios, by detecting a title of a porn movie.

Detecting a title in a noisy file name string is, in essence, a problem of finding the longest common sub-sequences, while at the same time allowing some degree of mismatch between the sequences that should be matched as similar. The sheer number of titles in the database makes identification a non-trivial task, and the fact

that it has to be performed for multiple files as quickly as possible, only adds to the complexity.

The field of bio-informatics provides a range of approaches to this problem. It is a very common activity to align two genome sequences in order to establish if there are similarities that may hint at functional, evolutionary or structural relationships between them.

The essential purpose of the alignment is to capture regions which are either the same or similar (e.g. where particular characters may be swapped without losing the overall meaning of the sequence).

<b>Movie</b>	The Bourne Legacy (2012)
<b>Torrent</b>	Jason Bourne 04 - La peur dans la peau - L'héritage [ATG 2012] 720p.mp4

Table 13: Example of a Movie Title and Torrent Name for Alignment

Consider the torrent name and the movie title from Table 13 aligned in Figure 10. The pairs of the same characters are marked with an asterisk below them; and whenever a mismatch occurs, a *gap* is inserted in one of the sequences, which is denoted by a dash. A sequence alignment function is also able to produce a particular score that denotes the degree of similarity. It is configurable in terms of how subsequent matches or mismatches should be treated, or which characters are interchangeable and to what degree.

The-----	Bourne	-----L---	eg----	acy--	(-----2012)-----
-----Jason	Bourne 04 -	La pe-ur	da--ns	-la	peau - L'héritage [ATG 2012-] 720p.mp4
	*****		* * *		****

Figure 10: Torrent Name and Movie Title Aligned

One of the first widely adopted methods for sequence alignment is the Needleman–Wunsch algorithm (Needleman & Wunsch 1970), which is an example of dynamic programming, whereby a complex problem is broken up into smaller sub-problems and solved gradually. It computes a matrix  $F_{m,n}$ , where  $m$  and  $n$  are the lengths of the sequences, and calculates a score of all possible global alignments (i.e. total resulting sequence), and then finds the most optimal alignment. A

variation of the Needleman–Wunsch method is the Smith–Waterman (SW) algorithm (Smith & Waterman 1981), which is more concerned with local alignments (i.e. alignment of sub-sequences) by comparing segments of all possible alignments and optimising the resulting similarity measure. The SW variation is more relevant to this thesis as it specifically addresses partial alignments, which may provide additional evidence for the classification model.

BLAST (Altschul et al. 1990) is one of the most widely used tools for sequence alignment in bioinformatics (Casey 2005), and features a heuristic algorithm based on matching sequences of *n*-grams, an *n*-gram being a sequence of *n* characters. Using such a technique provides an opportunity for a much shorter processing time with a subsequent detailed alignment where applicable.

Table 14 provides an example of breaking up a movie title ‘Matrix’ into 3-grams:

<b>Original</b>	MATRIX			
<b>3-Grams</b>	MAT	ATR	TRI	RIX

Table 14: 3-Gram Example of ‘Matrix’

Matching strings as *n*-grams is faster than sequence alignment and provides a quick method of establishing whether it is even worth it to attempt sequence alignment.

Most sequence alignment algorithms share a very important feature, allowing us to define a substitution matrix e.g. BLOSUM (Henikoff & Henikoff 1992), which specifies a degree of similarity between each pair of amino acids. For example, it may specify that matching amino acids C and A should result in a higher score than C and P. Ultimately, a substitution matrix allows for identifying similar sub-sequences even after they were affected by mutations (e.g. where not all characters match exactly).

Additional tuning is possible via implementing a particular scoring policy, which can dramatically impact the resulting alignment. A gap occurs when the algorithm

decides that it is more expensive score-wise to match two incompatible characters than to shift one of the sequences to the right or left by inserting a gap. Gap starters and gap extenders can be treated differently and some gapping policies may favour long gaps over a lot of small gaps by making a gap starter expensive and a gap extender cheap. Table 15 illustrates how different gapping and scoring rules can impact the final alignment. The scoring rules used in our approach are explained further in Section 4.4.

<b>Movie Title</b>	The Matrix (1999)
<b>Torrent Name</b>	(TheNeo) Mediatrix (Into the matrix) [2011]
<b>Alignment Rule Set 1</b>	-The---- M---atrix (1999-----)----- (TheNeo) Mediatrix (----Into the matrix) [2011] *** * ***** *
<b>Alignment Rule Set 2</b>	-----The Matrix- (---1999)-- (TheNeo) Mediatrix (Into the matrix) -[201----1] ***** *

Table 15: Alignment Example under Different Rules

We briefly cover the Smith-Waterman algorithm as it is relatively simple to implement and provides a sufficient insight into the string alignment theory. In a classical implementation a matrix  $M_{n+1,m+1}$  is constructed where  $m$  and  $n$  are the lengths of the two strings being aligned. Alignment of 'Mediatrix' and 'Matrix' results in a 10 by 7 matrix.

The matrix is filled according to the scoring rules, which in this example are:

- match same characters: 2
- match different characters: -1
- gap: 0

This means that positioning the same characters opposite each other bears a score of 2, different characters opposite each other result in a score of negative 1 and simply shifting either string one position is a zero score. The top-left cell is always a 0, and all other cell scores are calculated using the formula:

$$M_{i,j} = \max \begin{cases} 0 \\ M_{i-1,j-1} + \text{match}(i,j) \\ M_{i,j-1} + \text{gap}(j) \\ M_{i-1,j} + \text{gap}(i) \end{cases} \quad (30)$$

Top and left rows will be hence filled with zeroes, representing an entry point before any characters were matched. The remaining matrix is then eventually filled with scores as in Table 16.

Mediatrix										
M---atrix										
	-	M	E	D	I	A	T	R	I	X
-	0	0	0	0	0	0	0	0	0	0
M	0	2	2	2	2	2	2	2	2	2
A	0	2	2	2	2	4	4	4	4	4
T	0	2	2	2	2	4	6	6	6	6
R	0	2	2	2	2	4	6	8	8	8
I	0	2	2	2	4	4	6	8	10	10
X	0	2	2	2	4	4	6	8	10	12

Table 16: Example of Alignment and Score Matrix

Whenever we move diagonally, this means that characters were matched, and horizontal or vertical movement is a result of inserting a gap. Once all the scores are calculated, the algorithm backtracks the alignment from the last cell which had the best score. It then moves backwards building up the final alignment strings by selecting a cell that bears the least score loss compared to the current cell, preferring the diagonal movement if multiple cells have the same score record. In many cases two strings can be aligned in multiple ways with the same final score.



## 2.8. Summary

In this chapter we introduced a commercial benchmark system MVL developed by MovieLabs that provided results for comparison to our prototype classifier Toran. We explained the input data, which is a list of basic torrent information, such as unique identifier, download's name and file size. It is supplemented with a database of movie, TV series and game titles, as well as a limited set of names of porn actors and studios.

We explained the classification taxonomy originally used by MVL and highlighted its drawbacks, and introduced the Toran classifier system which we used to test the application of our methodology.

As part of our study we used human participants to help us construct data samples and manually classify and identify several thousand torrent files. A small subset of these items was also fully downloaded and its content verified. Other data sets were also developed to evaluate prediction of fakes and malware, and to provide confident results about medium classification on an independent test set. These data, together with benchmark classifications, were separated into four data sets which are explained in this section and can be found in Appendix D.

## Chapter 3

# Torrent Name Bayesian Network Model

This chapter directly addresses *Research objective 1* (from Section 1.2) by providing a novel BN model that lies at the heart of the torrent identification and classification system Toran. It was developed using a combination of data and expert domain knowledge, rather than a straight ML approach for reasons explained further in this chapter.

The chapter first provides relevant theory about Bayes' theorem and Bayesian modelling in Sections 3.1, 3.2 and 3.3. It then gives a brief overview of the whole model in Section 3.4 and explains every part in more detail in Sections 3.5 to 3.12, also providing judgement for the conditional probability definitions of any relevant nodes, and how various concepts within the model evolved over time. While some evidence observed in the model is trivial, such as 'file size', other evidence is captured through a complex process, which is explained in Chapter 4. Elsewhere in this chapter relevant references are provided pointing to evidence capturing procedures. Section 3.13 outlines our ideas for possible extensions of our model and the procedure to be followed.

The material in Sections 3.4 to 3.13 and application specific examples in Sections 3.1 to 3.3 are, to the best of our knowledge, a novel contribution.

### 3.1. Bayes' Theorem

Bayes' Theorem (Bayes & Price 1763; McGrayne 2011; Fenton & Neil 2012b; Barber 2012) is named after Thomas Bayes who, in 1763 showed how initial beliefs can be updated by new evidence. It describes the relation of prior probability before evidence and the posterior probability once some evidence is observed. Formally, it describes the probability of some unknown event  $H$  given evidence  $E$ :

$$P(H|E) = \frac{P(E|H) P(H)}{P(E)} \quad (31)$$

where  $P(H)$  is the *prior* probability of  $H$ ,  $P(E|H)$  is the *likelihood* and  $P(H|E)$  is the *posterior* probability of  $H$ . When  $P(E) = 0$ ,  $P(H|E)$  is not defined. When  $H$  is a set of  $n$  mutually exclusive and exhaustive events, we can express the probability of the evidence by the law of total probability (Zwillinger & Kokoska 2000) as:

$$P(E) = \sum_{i=0}^n P(E|H_i) P(H_i) \quad (32)$$

A practical example that is relevant to the problem domain, considers fake items. We know that highly anticipated titles or those that have been released recently are most at risk of being faked on the file sharing networks. Some of these fakes could be broken videos, while others could contain malware. Therefore, it is important to assess the risk that a downloadable item is in the risk group, a fake and subsequently – concealed malware.

Imagine that, based on information such as a database of recently released movies and/or expert judgment, there is a test to determine whether a torrent is a fake or not by analysing its name. Suppose the test is accurate enough to conclude an item to be a fake in 99% of cases when it is an actual fake, and in 5% of cases when it is not a fake. So the true positive rate for the test is 99% and the false positive rate is

5%. Suppose, we can estimate that for the torrents posted more than 2 months ago, around 5 in 1000 are fakes. Then for this class of torrents we have:

$$\begin{aligned}
 P(\text{Fake}) &= 0.005 \\
 P(\text{Detected}|\text{Fake}) &= 0.99 \\
 P(\text{Detected}|\neg\text{Fake}) &= 0.05
 \end{aligned}
 \tag{33}$$

According to the rule of total probability (Zwillinger & Kokoska 2000):

$$\begin{aligned}
 P(\text{Detected}) &= \\
 P(\text{Detected}|\text{Fake})P(\text{Fake}) + P(\text{Detected}|\neg\text{Fake})P(\neg\text{Fake}) &= \\
 0.99 \times 0.005 + 0.05 \times 0.995 &= 0.0547
 \end{aligned}
 \tag{34}$$

We are interested in the chance that the item really is a fake given that the match was positive:

$$\begin{aligned}
 P(\text{Fake}|\text{Detected}) &= \frac{P(\text{Detected}|\text{Fake}) P(\text{Fake})}{P(\text{Detected})} = \\
 \frac{0.99 \times 0.005}{0.0547} &\approx 0.091
 \end{aligned}
 \tag{35}$$

This means that even if our test determines the torrent to be a fake, the chances are that it is a false positive, because the initial probability of finding such an item is very low. This means that the test for fake items must be made more accurate, or accompanied by another test.

	Not Fake	Fake
Not Detected	94525	5
Detected	4975	495
Total	99500	500

Table 17: Illustration of Fakes Detection Test

Table 17 illustrates this example applied to a random selection of 100,000 items. In the rest of this chapter we demonstrate how we apply Bayes' theorem in building a probabilistic model to address the problem of item classification in the problem domain context.

## 3.2. Bayesian Networks Overview and Key Concepts

This section provides an overview of Bayesian networks (BNs) covering those aspects necessary for the thesis and is structured as follows: Sub-section 3.2.1 provides an essential definition of BNs. Sub-section 3.2.2 gives relevant BN examples. Sub-section 3.2.3 outlines the key properties of BNs, relevant tools, applications and briefly covers the Bayesian inference methods. Sub-section 3.2.4 explains the difference between hard, soft and virtual evidence. Sub-section 3.2.5 outlines how continuous nodes are modelled in AgenaRisk.

### 3.2.1. Bayesian Network Definition

A Bayesian Network (BN) is a graphical probabilistic model (Pearl 1988; Edwards 2000; Nielsen & Jensen 2009; Koski & Noble 2009), consisting of variables or events, formally called *nodes*, connected with arrows, formally called *edges* and representing causal or influential relationships between the nodes. The collection of nodes and edges is called a *graph* or *topology*. For a pair of events  $A$  and  $B$  in a relationship  $A \rightarrow B$ ,  $A$  is called *parent* and  $B$  is called *child*. Nodes that do not have a parent are called *root* nodes. A BN is a type of *directed acyclic graph* (DAG), which implies that no node can be an ancestor to itself, and that all edges are directed (Christofides 1975; Thulasiraman & Swamy 1992).

There are many possible types of nodes such as Boolean, labelled, ranked, and continuous or integer intervals. Depending on the node type, random variables represented by the nodes, are either discrete or continuous. In the former case the range of values must be an exhaustive collection of mutually exclusive states (e.g. “True” and “False”; or “Low”, “Medium” and “High”). In the latter case we can define ranges, but the actual variable can take any value allowed by the node type. For example, for a continuous integer type node, we may define ranges  $(-\infty, -11]$ ,  $[-10, 10]$ ,  $[11, +\infty)$ , allowing the variable to take any integer value. However, the

number of states of the variable is then 3, which makes it possible to process continuous nodes in the same manner as discrete nodes.

Each node has an underlying *node probability table* (NPT), also called *conditional probability table* for child nodes. For a node *A* without parents the NPT is simply the prior probability of each state of *A*. For a node *B* with parents the NPT specifies for each state of *B*, the probability of that state given all combinations of the states of the parents of *B*.

### 3.2.2. Simple BN Examples

Consider the example of fakes detection illustrated in Table 17 and a very simple corresponding BN in Figure 11. It is very important to note that the causation is expressed in this case by the arrow going from *Torrent is Fake* to *Evidence of Fake Detected*, because the result depends on the input, and not the other way around. However, correct inference in BNs is also possible when edges do not follow causation direction.

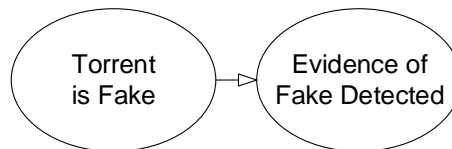

Figure 11: Basic BN for Fakes Detection

Considering the set of newly added records, the prior for a file name to contain a risky title was set at 30 in 100, which has to be first normalised so that it adds up to 1. Leaf nodes like *Torrent is Fake* have a very simple NPT such as in Table 18.

<i>Torrent is Fake</i>	<b>False</b>	0.7
	<b>True</b>	0.3

Table 18: NPT for *Torrent is Fake* in the Basic Model

*Evidence of Fake Detected* is a child node, so we have to specify probability values based on detection accuracy, which is assumed to be 99% for cases where there really is a risky title and 95% otherwise, as shown in Table 19.

	<i>Torrent is Fake</i>	False	True
<i>Evidence of Fake Detected</i>	False	0.95	0.01
	True	0.05	0.99

Table 19: NPT for *Evidence of Fake Detected* in the Basic Model

Once an observation is entered into the *Evidence of Fake Detected*, it back-propagates to *Torrent is Fake* as in Equation 35 as the model calculates the posterior probability of *Torrent is Fake* (see Figure 12).

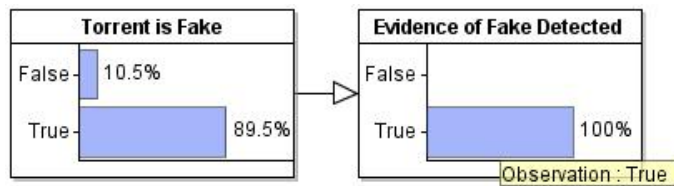

Figure 12: Basic BN for Fakes Detection Example after Evidence Propagation

Now, in practice, the test to determine whether a torrent is fake based on its name will depend on a number of factors. One such factor is the *Database Coverage* (where we assume the test involves looking up a database of ‘risky titles’). In this case we revise the BN model shown in Figure 11 by adding an extra parent to *Evidence of Fake Detected* as shown in Figure 13.



Figure 13: Revised Example Model for Fakes Detection

If a node has multiple parents its NPT table becomes increasingly complex because the number of cells in the table is equal to the product of the number of options each parent variable can take. Suppose the variable *Database Coverage* has just two states “high” and “low”, which may correspond to the proportion of movie titles in the database out of all titles filmed. Clearly the accuracy of our test is going to be influenced by whether or not we have a sufficient number of titles in our database.

		<i>DB Coverage</i>				
				<b>Low</b>		<b>High</b>
		<i>Torrent is Fake</i>	<b>False</b>	<b>True</b>	<b>False</b>	<b>True</b>
<i>Evidence for Fake Detected</i>	<b>False</b>		0.99	0.7	0.95	0.01
	<b>True</b>		0.01	0.3	0.05	0.99

Table 20: NPT for *Evidence for Fake Detected* Example with 2 Parents

Table 20 illustrates a possible revised NPT for *Evidence of Fake Detected* in the more complex version of the model. If the database coverage is “Low”, evidence can only be correctly detected in 30% of cases when it actually is in the name string, as opposed to 99% detection rate with a “High” coverage database. We also assume a “Low” database coverage may rarely lead to false positives while a “High” coverage may cause a higher number of false positives due to file names matching something in the database.

Figure 14a shows the model in its prior marginal state before any observations are entered. Note that observing the evidence for a fake yields a high confidence in the prediction that the item is fake (Figure 14b, c), regardless of the database state. However, when we do not observe any evidence of a fake, there is an important difference. In Figure 14d our prior belief in 30% chance of a fake is only weakly affected, because database coverage is low. In this scenario failing to observe any evidence of fakes is likely due to having insufficient data rather than because the item was not a fake.

On the other hand, when database coverage is high as in Figure 14e an item that is a fake is very strongly expected to be properly detected, hence failing to observe evidence for a fake leads us to believe that the item is not one.





Figure 14: Possible Outcomes of the Fakes Detection Model: a) Show the marginal values before propagation, b-e) Show the values after propagation with the given observations

From consulting with domain experts and studying the problem domain, we determined a possible improvement to the model in Figure 13. This extension may be motivated by inclusion of a relation between the type of an item and its prevalence to be a fake. For example, we know that most fakes are disguised as movies, and we can express this by adding two new nodes *Item is Movie* and *Item Looks Like Movie*, as in Figure 15.

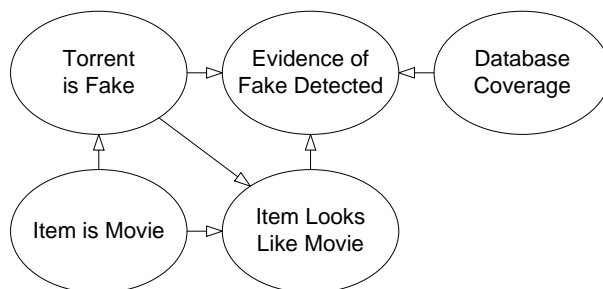

Figure 15: Extended Example Model for Fakes Detection

This extension allows us to specify that an actual movie is very unlikely to be a fake, while items that are fakes or movies are very likely to appear as movies too. Items that appear as movies and are fakes at the same time, are likely to contain evidence for fakes, such as a title of a highly anticipated movie.

### 3.2.3. Bayesian Network Inference Algorithms, Tools and Applications

While the Bayesian inference calculations in the above 3-node model for fakes detection example can be computed manually, the necessary calculations quickly become intractable as more nodes and edges are added. For example, inference in the extended model in Figure 15 is already extremely complex to undertake manually. Indeed, the general problem of exact inference for an arbitrary BN is known to be NP-hard (Cooper 1990). However, in the late 1980s efficient propagation algorithms were developed for a broad variety of BNs (Pearl 1988; Henrion 1988; Lauritzen & Spiegelhalter 1988). These algorithms have subsequently been implemented in widely available software tools. To run the necessary computations for the BN model and associated classification and identification method developed in this thesis, we use the application program interface (API) of one such tool AgenaRisk (Agena 2016c). AgenaRisk employs the *junction tree* propagation algorithm (Jensen & Nielsen 2007), which we describe in Appendix E.

With the advent of widely available BN tools, there has been an explosion of interest in BNs since the mid-1990s with BN-based decision support applications developed in a wide range of fields (Fenton & Neil 2012b; Pourret et al. 2008). These include: making high-stakes critical real-time decisions at the NASA Mission Control Center (Horvitz & Barry 1995); device fault diagnostic and troubleshooting (Breese & Heckerman 1996; Skaaning et al. 2003); pharmacokinetic analysis (Gelman et al. 1996); medicine (Díez et al. 1997) (Burnside et al. 2006; Fenton & Neil

2010); analysis in genetics (Friedman et al. 2000; Jansen et al. 2003; Jiang et al. 2011); vehicle reliability for the military (Neil et al. 2001); terrorist attack detection (Laskey & Levitt 2002); Air Traffic Control environment (Neil et al. 2003); railway accident causation (Marsh & Bearfield 2004); football predictions (Constantinou et al. 2012); software reliability (Fenton & Bieman 2014); reliability of complex systems (Marquez et al. 2010), law (Fenton 2011; Keppens 2011; Fenton et al. 2013).

Compared to classical statistics, BNs provide the following benefits (also note that c and e cannot be achieved with rule-based decision support systems):

- a) *Modelling causality* allows a BN to be explained to a domain expert who is not necessarily a statistician. When data is not available, it is still possible to model causal relations between significant variables by eliciting probabilities and likelihoods from the domain experts. This is crucial because in many classical statistical methods such as regression analysis (Seber & Lee 2003), observational data is analysed for direct correlation clues, and may lead to wrong assumptions about causation (Armstrong 2012; Cook & Weisberg 1982; Freedman 1991). Moreover, such methods do not allow inclusion of any kind of logical reasoning that must apply regardless of data, e.g. an argument that while predicting software defects, performing no testing would yield no defects (Fenton et al. 2007). Likewise, regression models are incapable of adequately incorporating very rare events that a domain expert may consider possible in future.
- b) *Combining different types of evidence* makes it possible to encode objective data and subjective beliefs into the model (Heckerman 2008) and allows setting the type of data and NPT individually for each variable.
- c) *What-if analysis* is possible because causal BNs allow differentiation between observations and interventions. As defined in (Pearl 2009), an intervention on a variable *A* simply sets the variable to a desired state and cuts off edges leading from its parents to disable back-propagation, which enables us to

avoid a correlation due to unmeasured common causes and highlights direction of causality.

- d) *Back-propagation* of evidence from effect to cause provides crucial backward reasoning that enables powerful predictions. Once an observation is entered in an effect node, it updates probability distribution of its cause, as per Figure 12.
- e) *Explaining away*, as in the fakes detection example in Figure 14 above, where the probability of the torrent being a fake is discounted when other reasons for detecting evidence of fake are observed. For example, when some evidence is found and the database coverage is low, the final confidence is higher that the item is a fake. However, if the database coverage was high, it is considered to be the more likely reason for detecting the evidence (i.e. false positive) and the posterior probability of fake is reduced.
- f) *Visible auditable reasoning* means that it is possible to work out why exactly the model arrived at a particular prediction, which may be a great debugging opportunity.
- g) *Computing predictions despite missing evidence* is crucial for many real world applications, because we cannot rely on always having sufficient data, nor do we actually have that much data in reality. With no observations entered, a BN would return predictions that represent our prior belief, and with more evidence added, the more accurate the final predictions will become.

While Bayes' theorem provides a rational and correct way to characterise uncertainty of an unknown hypothesis as new evidence is observed, there is no universal acceptance of the need for Bayes or even the need to capture uncertainty at all. There are also two common specific objections to using Bayes:

1. *Need to specify prior probabilities*: There is a special concern when this requires subjective judgment. This arises from a philosophical debate going on in the field of probability analysis (Kendall 1949; Casella & Berger 1987;

Gelman 2008; Senn 2011) for decades, concerning the definition of probability itself and involving the comparison of frequentist and Bayesian schools of thought. The frequentist approach considers drawing probabilities from directly observing data, while the Bayesian considers probability to be a function of logic and revolves around updating initial subjective prior with subsequent objective evidence. It can be argued that with sufficient data one can arrive at an objective probability of a variable by simply observing the frequency of that variable in a big enough sample. However, this fails to address cases where little or no historical data is available while expert judgment may be in abundance. The Bayesian approach joins data and knowledge allowing better decision-making when data is scarce (McGrayne 2012).

2. *Complexity of the Bayesian calculations*: This is, of course, especially relevant when there are multiple dependent variables. Fortunately it is alleviated by using Bayesian networks and automated tools that implement the necessary inference algorithms.

#### 3.2.4. Hard, Soft and Virtual Evidence

Whenever evidence is entered into a node, it is usually 'hard evidence' that is considered, which means that one node state is assigned a probability of 1 and the other states of 0. However, in real world applications we sometimes can only obtain uncertain evidence in cases when we are not entirely sure about the observation. For example, we could be 90% certain that a Boolean node is true, but this means that we cannot use hard evidence to express this. In fact, the model should propagate and return marginal values for the states of "true" and "false" as 0.9 and 0.1 respectively. Such implementation is called *soft evidence*. However this is technically difficult to implement (Fenton et al. 2012), so commercial tools

normally implement *virtual evidence* (Pearl 1988) which uses a likelihood ratio defined as:

$$P(Ob(a_1)|a_1) : \dots : P(Ob(a_n)|a_n) \quad (36)$$

where  $n$  is the number of states of the variable  $A$ ,  $P(Ob(a_i)|a_i)$  is interpreted as the probability of observing state  $a_i$  when  $A$  is indeed in this state. Then the posterior probability  $P(A = a_m|Ve)$  is defined as:

$$P(A = a_m|Ve) = \frac{P(a_m) \times P(Ob(a_m)|a_m)}{\sum_i P(a_i) \times P(Ob(a_i)|a_i)} \quad (37)$$

where  $Ve$  denotes ‘virtual evidence’. To illustrate, a Boolean variable with prior probability for true being 0.2 and virtual probability for true being 0.9 would result in a posterior probability:

$$\frac{0.9 \times 0.2}{0.9 \times 0.2 + 0.1 \times 0.8} \approx 0.69 \quad (38)$$

We use virtual evidence in the model for title identification in cases of multiple title category matches per torrent name, as explained further in Section 3.11.

### 3.2.5. Modelling Continuous Variables

Unlike other propagation algorithms which assume that numerical variables have a fixed set of pre-defined discrete states, the AgenaRisk inference algorithm implements dynamic discretisation as described in (Neil et al. 2007). The implementation is based on the ideas originally proposed in (Kozlov & Koller 1997) and is a more flexible alternative to approaches involving conditional Gaussian (Lauritzen & Jensen 2001; Lauritzen 1992), or mixtures of truncated exponentials (Cobb & Shenoy 2006; Rumí et al. 2006).

Specifically, in AgenaRisk it is possible to use all of the following distributions: Beta, Chi Squared, Exponential, Extreme Value, Gamma, Gaussian, Logistic, Log Normal, Student, Triangle, Truncated Normal, Uniform or Weibull. The dynamic discretization algorithm approximates the probability density function (PDF)  $f_x$  of

any of these distributions. It finds an optimal discretization set and optimal values for the discretised PDF  $f'_x$  via a series of iterations within an acceptable degree of precision. Unlike other Bayesian modelling software (Lunn et al. 2000; Stan Development Team 2014; Murphy 2014; Bayes Server 2015; Hugin 2015), AgenaRisk therefore provides an efficient and flexible way of modelling continuous nodes without having to manually specify discrete intervals or limit oneself to Gaussian distributions only.

We used continuous nodes in a supplementary BN to learn parameters of the size distributions for the main BN. Moreover, in revisions of the model following the original submission of this thesis, we use continuous nodes both for the size node and for the nodes that measure the level of evidence detected for each item category (e.g. category keywords and patterns, or file size).

### 3.3. Building Bayesian Networks

While Section 3.2 makes clear the benefits of a well-crafted BN once it is built, there are great challenges in actually building a sensible and useful BN for a given problem domain. This section describes the various methods used in this thesis to develop the BN model for file identification and classification and is structured as follows: Sub-section 3.3.1 compares two distinct approaches – knowledge engineering and machine learning – to building BNs. Sub-section 3.3.2 covers the topic of conditional dependency of variables. Sub-section 3.3.3 outlines some approaches to creating BN structure and lists the major steps in this process. Sub-section 3.3.4 provides an overview of popular approaches to learning prior probabilities for the model, including elicitation from domain experts. Sub-section 3.3.5 explains in detail theory behind reusable patterns called *idioms*, introduced first in Section 3.3.3 and how they are relevant to this project.

### 3.3.1. Knowledge Engineering versus Machine Learning

A good model lies at the heart of proper probability analysis, and it is important to capture the structure of the model and define prior and conditional probabilities. A natural approach is *knowledge engineering* (KE), which aims to exploit the experience, judgement and knowledge of the domain experts and elicit from them the BN structure, any possible causal relationships between variables, and probabilities.

Although BNs are originally motivated by the knowledge and insight of domain experts, there is a separate branch of Bayesian modelling, which employs *machine learning* (ML) methods (Neapolitan 2003; Murphy 2012; Barber 2012) and is concerned with both model structure and the prior and conditional probabilities being learned from the data itself, such that the resulting model describes the data sample. Because ML implementations naturally recover a model that best describes the data, it is important to consider the possibility of the analysed sample being insufficiently large.

In practice, however, it is often sensible to integrate knowledge-based and data-driven approaches. A number of theory refinement methods are discussed in (Buntine 1991), some of which revolve around the idea of starting with a network structure elicited from an expert and refining it with subsequent automated learning. Belief and causal networks are contrasted in (Heckerman et al. 1994) by enforcing different requirements on automated learning methods, which shows how domain knowledge impacts the learning process even in the early stages of model type definition. A method for specifying constraints into a model learning process is proposed in (Altendorf et al. 2005; Zhou et al. 2014; Zhou et al. 2015). Such constraints represent the proportional relation between variables. A framework allowing an expert to define hard constraints on the structure and soft constraints on the priors is proposed in (de Campos & Qiang 2008). A method



based on dependency analysis aimed at learning structure from incomplete datasets by making assumptions about missing data to fill the gaps, is proposed in (Fiot et al. 2008). It is suggested in (Cano et al. 2011) to learn the structure of the BN automatically, but confirm certain low-confidence parts of the structure with an expert. Work in (Flores et al. 2011) presents an overview of several methods allowing an expert to specify the full structure; identify causal direct links; causal dependency; relation (i.e. edge) directions; identify related variables with unknown relation direction; temporal tiers, where variables are grouped within timeline; or correlations. The method proposed in (Khan et al. 2011) is based on an expert executing an evidence gathering test at each step of the learning procedure.

The example provided in (Fenton 2012) illustrates a common situation whereby it is impossible, even when there is an extremely large data sample for a small number of variables, to use a machine learning or frequentist approach to learn a simple relationship easily known to an expert. An example in (Fenton 2014) illustrates how a model refined by expert judgement can provide more semantic insight and lead to better decision making. Another example in (Fenton 2015a) illustrates how a data-based approach may have to arrive at a wrong model, due to a critical semantic meaning not explicitly present in the data set. Yet an expert can identify semantics missing from the data and help create a correct model. An illustration of how data-driven approaches may fail to identify crucial interventions that may impact the data critically, is presented in (Fenton 2015b). It is clear that employing, at least to some degree, expert judgement is preferable to a pure machine learning approach, to be able to cope with inadequacies of data.

This thesis is concerned with analysing data where a sufficiently large validated sample with known actual item categories may not be available for implementing ML approaches appropriately; hence the rest of this section refers to KE methods.

### 3.3.2. Conditional Dependency

When linking nodes together, it is important to consider that from the mathematical standpoint  $A \rightarrow B$  structure is just as valid as  $B \rightarrow A$ . However, from the practical perspective it may be better to select the parent based on whether it is easier to define the unconditional rather than conditional prior probability for it, or if maintaining the causal relation allows for a more transparent model. For example, consider a variable *Collection*  $C$  that represents the source, from which we process torrent files, with possible values 'new' and 'old', and a variable *Fake*  $F$ . As noted in Sections 2.2 and 3.1, newly posted torrents are much more likely to be fakes and this increases the risk of malware.

Depending on the structure of the model, there can be two sets of priors to define:

1. For  $C \rightarrow F$ :  $P(C), P(F|C)$
2. For  $F \rightarrow C$ :  $P(F), P(C|F)$

It is simple to define the model in terms of known parameter *Collection* influencing the unknown parameter *Fake* because we can define the former based on the data being analysed. For example, we may know in advance which torrent collection the experiment will be running on, and whether the item in consideration is 'new' or 'old'. In such a case the prior probability of  $C$  does not matter because the variable is always observed, and can be set with an ignorant prior of 0.5 for each option. We can then use our expectation of a larger proportion of fakes among the 'new' items to define conditional priors of  $F$  given  $C$ . On the other hand, defining the prior unconditional probability of item being a fake is much more difficult than working out expected proportions based on other factors such as the recency of an item, or its medium which allows defining what kinds of media are more likely to be faked.

We can extend this model by including the real medium of the item. This allows specifying that fake downloads are mostly videos (e.g. broken videos) or software

(e.g. malware). Finally, to give a prediction of the risk of malware, the model is extended with another node that specifies that malware is mostly found in fakes that are in reality software. We end up with the model in Figure 16.

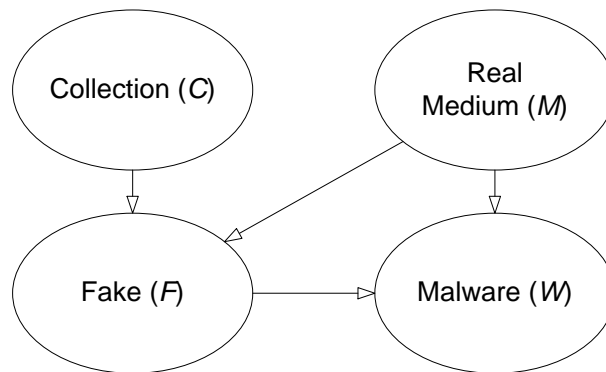

Figure 16: Basic BN for Input, Real Medium, Fake and Malware

In BNs there are 3 types of dependency connections (*d-connections*) identified in (Fenton & Neil 2012c), which are all found in Figure 16: converging, diverging and serial. Evidence flow between nodes depends on hard evidence being entered at the nodes between them as illustrated by Figures 17, 18 and 19.

a) *Converging* (Figure 17)

Node *F* has multiple parents *C* and *M*. If there is hard evidence entered at *F* or any its children, then *C* and *M* are dependency-connected (*d-connected*), meaning that any evidence entered at *C* will update posterior of *M* and vice versa. Otherwise they are dependency-separated (*d-separated*), meaning that there is no evidence flow between them.

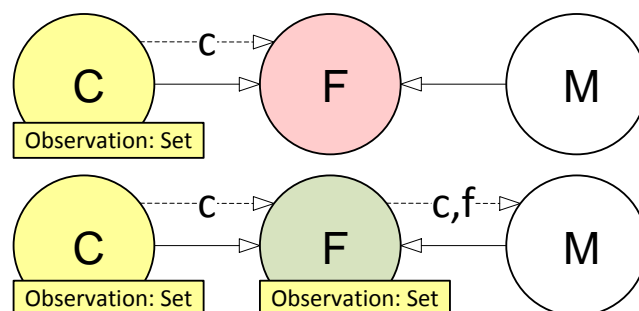

Figure 17: Converging Connection

b) *Diverging* (Figure 18)

Node  $M$  is a parent of multiple nodes  $F$  and  $W$ . If there is hard evidence entered at  $M$ , then  $F$  and  $W$  are d-separated. Otherwise they are d-connected.

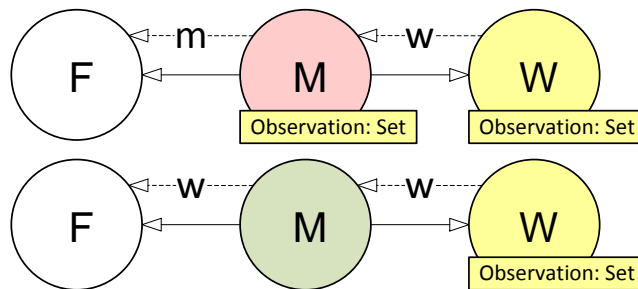

Figure 18: Diverging Connection

c) *Serial* (Figure 19)

Nodes  $C$ ,  $F$  and  $W$  are connected in a sequence such that  $F$  is conditionally dependent on  $C$ , and  $W$  is conditionally dependent on  $F$ .

If hard evidence is entered at  $F$ , then  $C$  and  $W$  are d-separated, and d-connected otherwise.

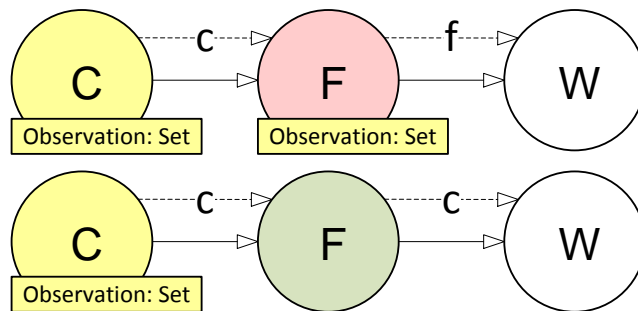

Figure 19: Serial Connection

The solid arrows on Figures 17, 18 and 19 represent the actual edges, while the dashed arrows illustrate information flow from *instantiated* nodes. *Instantiation* of a node refers to a hard observation being entered into that node. Note how information can flow in the direction opposite to the direction of the edge. Middle nodes with a pink background block evidence propagation between side nodes and make them d-separated. Middle nodes with green background allow d-connection and evidence flow.

### 3.3.3. Defining BN Structure

According to standard software engineering practices, a system should be built from modules or components, usually employing object-oriented (OO) methods (Goldberg & Robson 1983; Rumbaugh et al. 1991; Meyer 1998). A number of repeated concepts is identified, which are implemented and reused on a regular basis, and are called *design patterns* (Gamma et al. 1995; Jackson 1995). These patterns represent templates of recognised solutions to common problems. For example, most software systems have at least one object that is unique in its type, and accessed by many other components of the system. The *Singleton* design pattern structurally describes how this case may be implemented in a coherent way.

Extending this idea to BN construction, Laskey and Mahoney defined a method of organising parts of BNs into semantically meaningful units, which they called *fragments* (Laskey & Mahoney 1997). In this definition, all fragments can be constructed separately from each other, and each is a set of nodes related by edges and makes logical sense on its own. They build on this in (Laskey & Mahoney 2000) by proposing a system engineering approach where simple prototypes are created in iterations following a spiral lifecycle model, which are evaluated and amended. Following this approach allows the knowledge engineer to better understand the domain and the expert to acquire understanding of principles of Bayesian modelling.

Koller and Pfeffer argued that just like programming languages and databases benefit from an object-oriented approach, the BN building process could be improved greatly in the same fashion (Koller & Pfeffer 1997). They conceptualised object-oriented Bayesian Networks (OOBNs) where an object is a BN fragment which is viewed as a stochastic function with attributes that can be observed as inputs and predicted attributes as outputs, with some of the attributes being

private and not visible or accessible from outside of the object. Furthermore, an output node of one object can be an input node for another, which enables multiple levels of abstraction. The objects are encapsulated in a sense that only internal evidence can influence their outputs.

Building on the OOBN work, Neil et al. define a number of *idioms* (Neil et al. 2000), which are refined in (Fenton & Neil 2012d), and are analogous to design patterns in OO programming and generalise a set of very particular types of BN structure fragments which are viewed as building blocks for a BN. They also formalise the process of mapping a subset of nodes and edges to a particular idiom, allowing an engineer who is building the model to refer to this simple idiom selection rule when translating structure elicited from a domain expert to a BN. We use this approach extensively and a detailed explanation of both the idioms and how these idioms were used to develop the BN in the thesis is provided in Section 3.3.5.

Other related approaches to building BNs are:

- *Similarity networks* proposed by Heckerman (Heckerman 1990) which he used for disease diagnostic, but is not restricted to this domain. This method identifies the single hypothesis node called *distinguished node* (e.g. the disease) and produces a series of small disjoint knowledge maps of various variables related to the distinguished node. These are then merged into a large knowledge map. This method assumes that the smaller knowledge maps cover instances of the distinguished node that are exhaustive and mutually exclusive; that the distinguished node is not a child; and that the domain has only non-zero probabilities.
- *Causal maps* are defined in (Eden et al. 1992) as a directed graph which expresses judgement that certain actions or events will cause specific outcomes. Nadkarni and Shenoy propose an approach that elicits a *Bayesian causal map* (Nadkarni & Shenoy 2001) from experts via an interview and transforming it into a Bayesian Network (Nadkarni & Shenoy 2004).

In essence, building a BN can be summarised into the following steps:

- 1) Identify significant variables relevant to the problem, preferably using pre-defined relevant idioms, which also capture the node dependencies (i.e. edges).
- 2) For those variables that are not part of a pre-defined idiom construct, connect the variables with edges, preferably directed along causal links.
- 3) Identify correct type of all variables and what their values could be, and whether they are continuous or not.
- 4) Define prior probabilities for non-children nodes.
- 5) Define conditional probabilities for children nodes.

The steps 1 and 2 were covered above, and the next sub-section covers the steps 3 to 5.

#### 3.3.4. Prior and Likelihood Definition

It is a common argument that humans work best with qualitative rather than quantitative assessment (Pearl 1988; Spiegelhalter et al. 1993) and that domain experts and humans in general are prone to have difficulties or express biases when dealing with probabilities (Tversky & Kahneman 1974; Gigerenzer et al. 1998; Donnelly 2005; O'Hagan et al. 2006), and that addressing these issues is increasingly expensive and is generally infeasible (Renooij 2001). Because of such prevailing views, eliciting parameters from experts (Savage 1971) is focused on acquiring general notion of variables, relations between the variables, and degree and direction of impact.

Parameter elicitation is often done via interviews with experts (Nadkarni & Shenoy 2004) or questionnaires. Experts are normally asked to rate prior probabilities on a scale e.g. from 1 to 10, "very low" to "very high", a combination of numeric scale and text labels (van der Gaag et al. 2002), or using probability lotteries (Harrison et al. 2014).

While it is possible to perform sensitivity analysis to refine the elicited parameters by exploring sensitivity to edge removal (Renooij 2010), or more traditionally by inspecting how a target variable reflects changes to other parameters in its posterior probability, it is computationally expensive, especially when multiple parameters are adjusted simultaneously (Laskey 1995; Coupé et al. 2000).

With increasing complexity of models, the task of probability elicitation becomes more daunting. One technique called *divorcing* (Neil et al. 2000; Nielsen & Jensen 2009) is to reduce the number of parents a node has by introducing synthetic intermediate nodes, which in turn significantly reduces the size of the node's NPT and hence requires fewer probabilities to be entered. It is increasingly more common to apply approaches that allow us to avoid specifying probability values directly. Conditional probabilities can often be defined with a Noisy-OR model if an expert indicates that any cause can independently lead to a particular effect. A Noisy-AND model can be used if a combination of causes is required to achieve the effect (Henrion 1989; Pradhan et al. 1994; Zagorecki & Druzdzel 2004).

Another option is to consider using *qualitative probabilistic networks* (Wellman 1990) which are an abstraction of quantitative BNs, and use qualitative instead of numeric relationships with emphasis on synergy and degree of impact. When coupled with sensitivity analysis this method is claimed to be successful in arriving at meaningful likelihood values (Biedermann & Taroni 2006).

A special type of variable called *ranked node* was introduced in (Fenton & Neil 2007) that largely solves the problem of defining probability distributions for many commonly occurring nodes that have a scale-type list of ordered states e.g. "Very Low", "Low", "Medium", "High", "Very High". Such ranked nodes are modelled by a doubly truncated normal distribution (i.e. *TNormal*). Typically the ordinal scale has 3, 5 or 7 states, but the method described in (Fenton & Neil 2007), which is implemented in AgenaRisk, allows for any number of states since a ranked node has an underlying numerical range of 0-1; the  $n$  states are mapped to  $n$  equal



intervals within this range. Instead of manually defining all entries of the underlying probability table of the ranked node, it is possible to capture most common parent child relationships by a TNormal distribution whose mean is some kind of weighted type function of the parents. (Fenton & Neil 2007) demonstrated that four such weighted functions covered most common relationships (namely: weighted mean, weighted max, weighted min and a weighted min-max that combines min and max). Each of these is implemented in AgenaRisk.

In essence, only the relevant weighted function, together with the parent weights, needs to be elicited from the expert. The variance of the TNormal acts as a ‘credibility’ index and is directly proportional to the magnitude of the correlation between variables. Tests performed by Fenton & Neil and by Laitila & Virtanen (Laitila & Virtanen 2016) indicate that using this approach is much more reliable than eliciting every probability value for the NPTs manually and provides enormous effort savings.

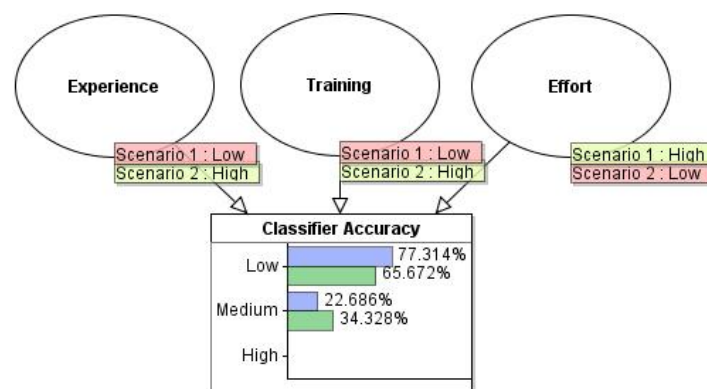

Figure 20: Example of using Ranked Nodes to Assess Classifier Accuracy

Figure 20 provides an illustration of a typical application of ranked nodes. In this case the child node “Classifier Accuracy” refers to the accuracy of a human classifier, which is impacted by their experience, training and the effort they put into the classification task. We may define all nodes as ranked, with 3 states each “Low”, “Medium” and “High”. We note that effort is an especially important factor, because no matter how good the expert is, a lack of effort will result in a job done poorly. Therefore we may define the weights for experience, training and

effort as 3, 3 and 10 respectively, and define accuracy as a weighted minimum of these parameters. In the figure we consider two polar scenarios. The first (blue) observes low experience and training, but high effort, which results in likely low accuracy of the expert. In the second scenario (green) the expert has high experience and training, but puts in a low effort, which also results in a low overall accuracy, which is in line with our assumptions. We could use any other weighted function, such as a weighted mean, but this particular option would not be suitable for this illustration, as it would allow high effort to overpower low experience and training and cause the model to incorrectly predict high accuracy.

### 3.3.5. Applying Idioms in the Project

Each idiom (as specified in Section 3.3.3) has its own semantic meaning, and dictates the edge directions. It needs to be noted that, although it is recommended that edges maintain causal directions (Koller & Friedman 2009; Fenton & Neil 2012a), it is not a hard requirement, as explained in Section 3.3.2. The following idioms were identified:

- 1) *Cause-consequence* idiom (Fenton & Neil 2012d) models a causal process in terms of the relationship between its cause (i.e. process input) and its consequence (i.e. process output).

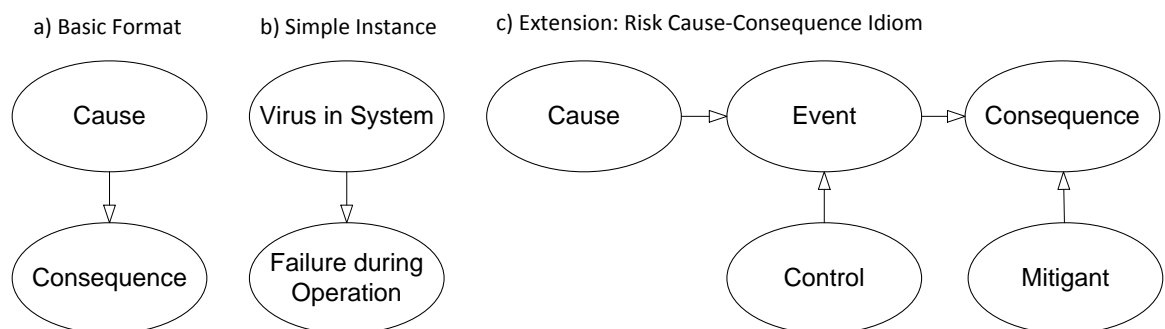

Figure 21: Cause-Consequence Idiom

Figure 21 shows the generic example in *a)*, its basic instantiation in *b)* and an extended generic example with controls and mitigants in *c)*, which is instantiated in Figure 22. The direction of the arrows in *a)* and *b)* indicates the causality

direction. The model describes the basic relation where one variable is a direct cause for another and models uncertainty about the cause when the consequence is observable.

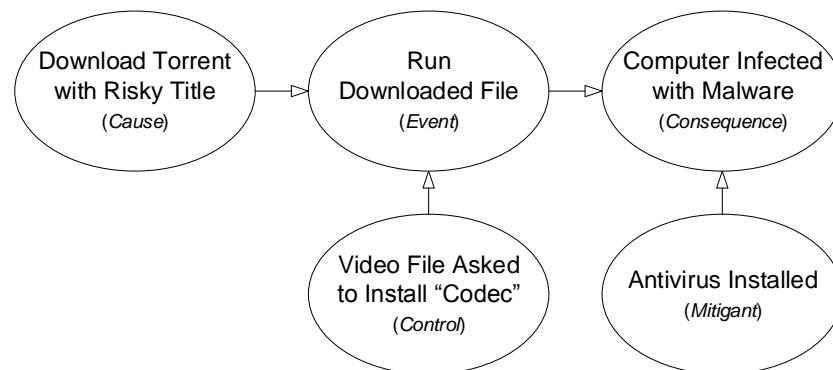

Figure 22: Cause-Consequence Idiom Example

Figure 22 gives an example instantiation of a risk cause-consequence idiom, showing how consequences can be influenced by *controls*, which are not direct causes but rather work in combination with them; and *mitigants*, which are combined with consequences to impact severity of the outcome.

2) *Definitional / synthesis* idiom allows for combination of information from multiple nodes into a single node via a non-causal relationship as seen in Figure 23. The synthetic node is determined by the values of its parent nodes according to a particular combination rule.

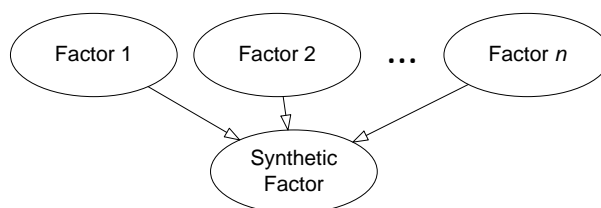

Figure 23: Definitional-Synthesis Idiom (Fenton & Neil 2012d)

We give two examples to illustrate this concept.

*a) Definitional Relationship*

Consider the task of identifying a torrent as a particular movie title. To do this, we need to compare the torrent's name to a candidate movie title. One of the ways would be to break up both strings of characters into a number of pieces of the

same length (e.g. sub-sequences 3 characters long) and count the total number of matching sub-sequences, to establish a very rough estimate of similarity between the torrent's name and the title. The maximum number of such overlaps can be calculated if we simply know lengths of the two compared strings.

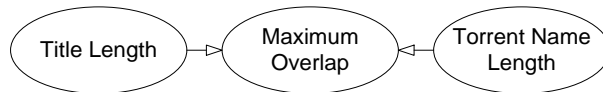

Figure 24: Definitional Idiom Example of a Deterministic Formula

Figure 24 illustrates how we can encode the *Maximum Overlap* node to serve as a function that takes as parameters *Title Length* and *Torrent Name Length* and calculates the result deterministically. Section 2.6 provides relevant background into string comparison for title identification.

**b) Synthesis to Reduce Combinatorial Explosion ('Divorcing')**

Within the context of risky title detection, we may design a basic model which takes account of not only database coverage but also quality of the torrent name string. The factors that we might be willing to consider are file name length, whether there is a mix of characters from different languages, and the chance that there was an intentional obfuscation of the name or unintentional misprints.

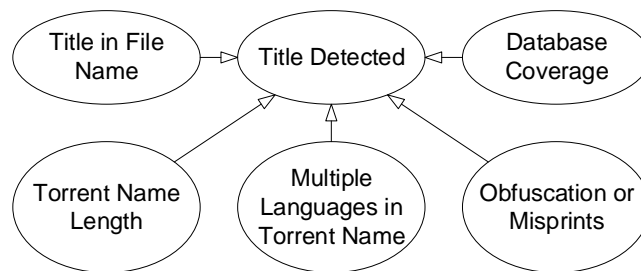

Figure 25: Synthesis Example for String Properties before Divorcing

Figure 25 demonstrates a model that combines multiple factors into a single node, resulting in a very big NPT. Separately defining each probability value in this NPT is impractical or extremely difficult. Table 20 demonstrated how NPTs increase in complexity with every new added parent, therefore it is important to keep the number of parents to a minimum if the NPT is to be constructed

manually. Suppose *Torrent Name Length* has 3 states (e.g. “Short”, “Medium” and “Long”) and the other nodes are binary. In this case the total number of cells in *Title Detected* NPT is 96.

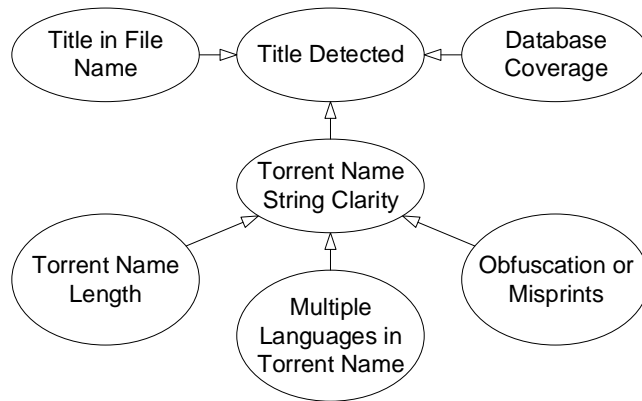

Figure 26: Synthesis Example for String Properties after Divorcing

Figure 26 demonstrates that by creating a synthetic node *Torrent Name String Clarity* which combines relevant nodes and has 3 states, we can reduce the number of cells from 96 to 24.

3) *Measurement* idiom captures uncertainty arising from the way in which a variable is measured. It relies on 3 components: the actual value or attribute, the assessed value or attribute and the assessment method’s accuracy, as shown in Figure 27.

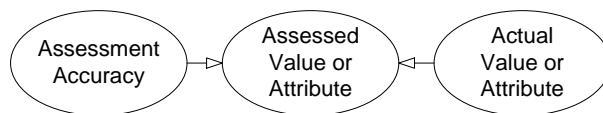

Figure 27: Measurement Idiom (Fenton & Neil 2012d)

In fact, a simple instance of the measurement idiom was already presented in Figure 13, where the attribute we are seeking to ‘measure’ is whether or not an item is a fake. As is common in all instances of the measurement idiom, the ‘actual value’ is normally not directly observable; instead the ‘assessed value’ (which is the test result in the example) is the approximation of it. The higher the assessment accuracy (i.e. the higher the database coverage is in the example) the more closely we expect the assessed value to reflect the actual value. If the assessment accuracy

is known to be low then generally the assessed value of the attribute tells us little about the actual value.

We may further improve the example model by including another important factor – *Torrent Name String Clarity* – such that the revised model is as in Figure 28.

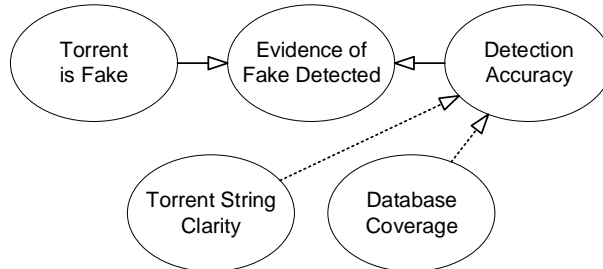

Figure 28: Fakes Detection as Example of Accuracy Measurement Idiom Instantiation

Note that dotted arrows represent the synthesis idiom instance, as multiple nodes are combined into a single synthetic accuracy node. Solid arrows are the ones making up the measurement idiom instantiation.

		<i>Torrent is Fake</i>			
		<b>False</b>		<b>True</b>	
		<b>Low</b>	<b>High</b>	<b>Low</b>	<b>High</b>
<i>Evidence of Fake Detected</i>	<b>False</b>	0.7	0.95	0.6	0.01
	<b>True</b>	0.3	0.05	0.4	0.99

Table 21: NPT for *Evidence of Fake Detected* in Accuracy Idiom Example

Let the NPT for *Torrent is Fake* be defined as in Table 18, and the NPTs for *Evidence of Fake Detected* and *Detection Accuracy* be defined according to Tables 21 and 22 respectively. *Torrent String Clarity* and *Database Coverage* are defined to be uniform.

		<i>Database Coverage</i>			
		<b>Low</b>		<b>High</b>	
		<b>Bad</b>	<b>Good</b>	<b>Bad</b>	<b>Good</b>
<i>Detection Accuracy</i>	<b>Low</b>	0.99	0.4	0.6	0.01
	<b>High</b>	0.01	0.6	0.4	0.99

Table 22: NPT for *Detection Accuracy* in Accuracy Idiom Example

The general motivation behind these example NPTs is that either bad name string clarity or low database coverage may cause low accuracy, but string clarity has a

higher impact. When accuracy is low, we effectively have low confidence in the results of the detection test, either positive or negative.

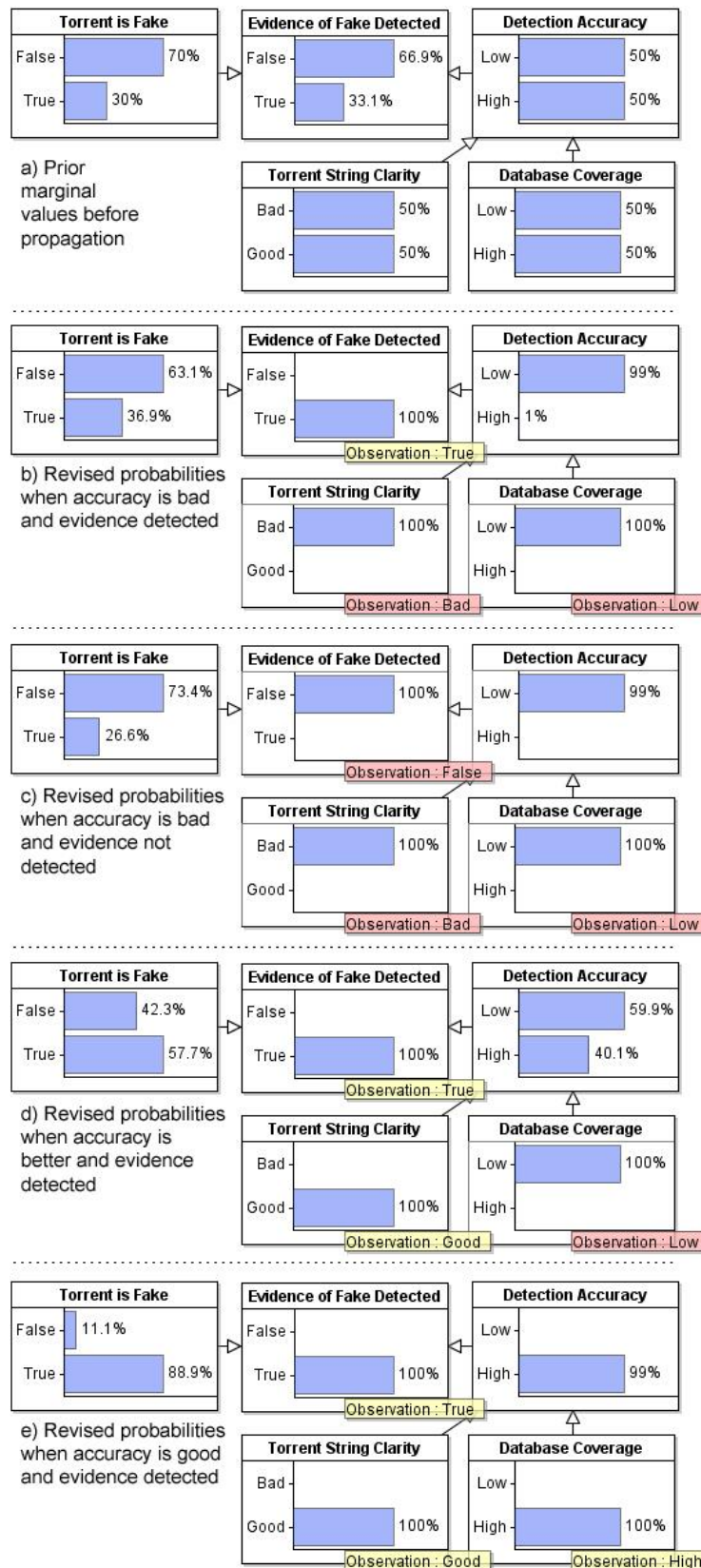

Figure 29: Extended Fakes Detection Model Demo

This is illustrated by scenarios *b* and *c* in Figure 29, where our prior belief about the item being a fake was almost unaffected by detected evidence due to low accuracy.

On the other hand, increasing the system's accuracy makes for a dramatic impact of detecting evidence on our posterior belief, as demonstrated by Figure 29*d* and to a larger extent by Figure 29*e*.

4) *Induction* idiom is used when a number of observations of the same event type are available, to make a prediction about an unknown event of this type, given contextual differences. A very simplistic example is parameter learning such as trying to learn movie length distribution based on a number of observed movie lengths in a user's collection.

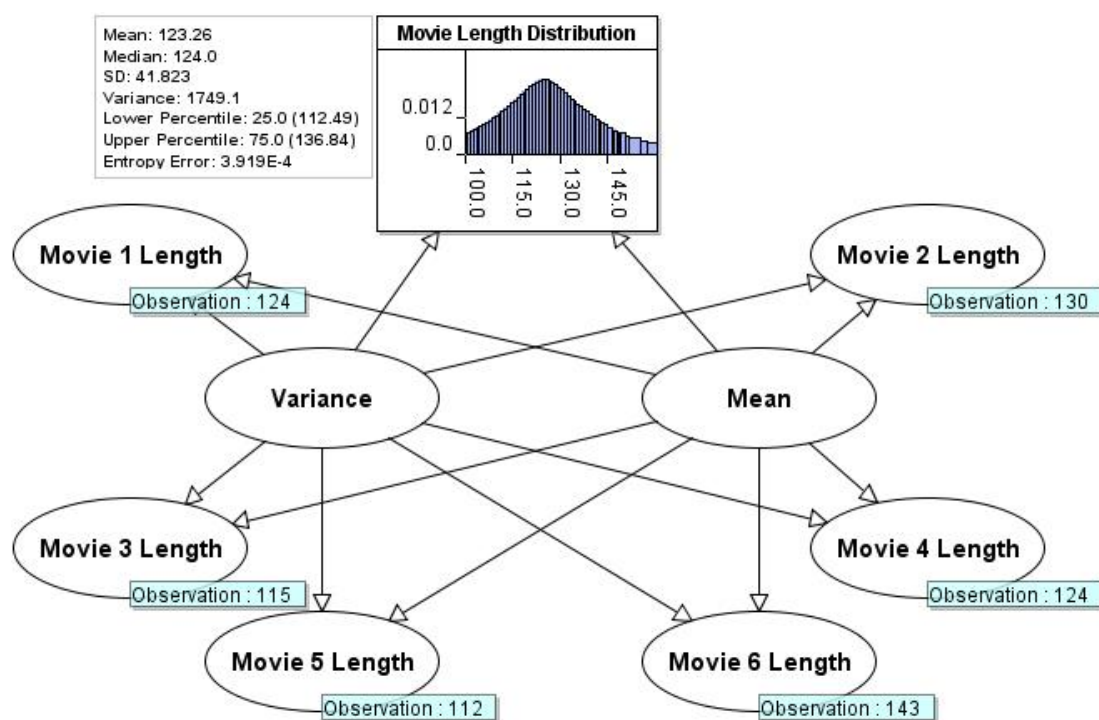

Figure 30: Induction Idiom Example

In the BN illustrated by Figure 30, we model movie length as a Normal distribution with unknown parameters *Mean* and *Variance*. The priors for both *Mean* and *Variance* are defined as uniform continuous distributions expressing our initial ignorance of movie length. By creating a node for each observed movie with NPT



defined as  $Normal(mean, variance)$ , we learn the *mean* and *variance* parameters and hence the movie length distribution.

The ‘contextual differences’ in this case (illustrated by Figure 31) would be whether we were trying to predict the length of an unobserved movie in a different user’s collection, knowing that the different user tends to be less patient, and therefore likely to watch movies of shorter length. We may add a contextual parent to the predicted node, and define the latter to consist of two partitions. One would apply if user is not impatient (the original prediction as in Figure 30), and the other would use a weight of e.g. 0.8 for the learnt mean to calculate the predicted movie length, as seen in Figure 31.

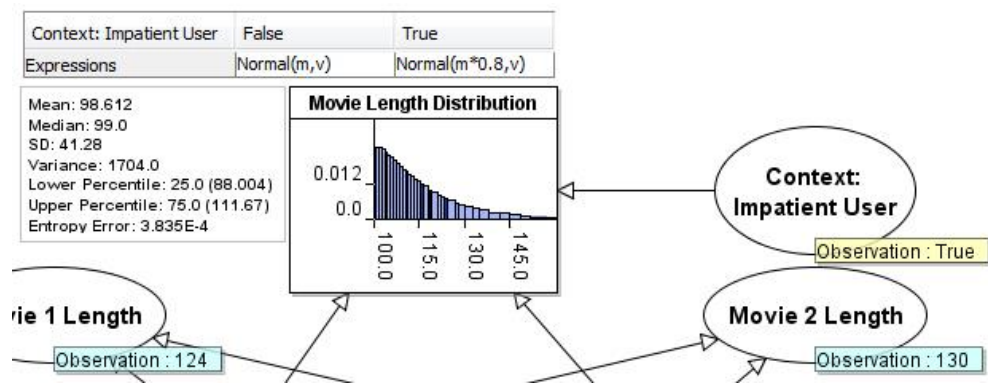

Figure 31: Effects of Contextual Differences on Learnt Distribution

Defining the idioms is an important step towards formalising the process of building BNs, and closing the gap between well-established software engineering procedures and BN-building practices.

### 3.4. Model Overview

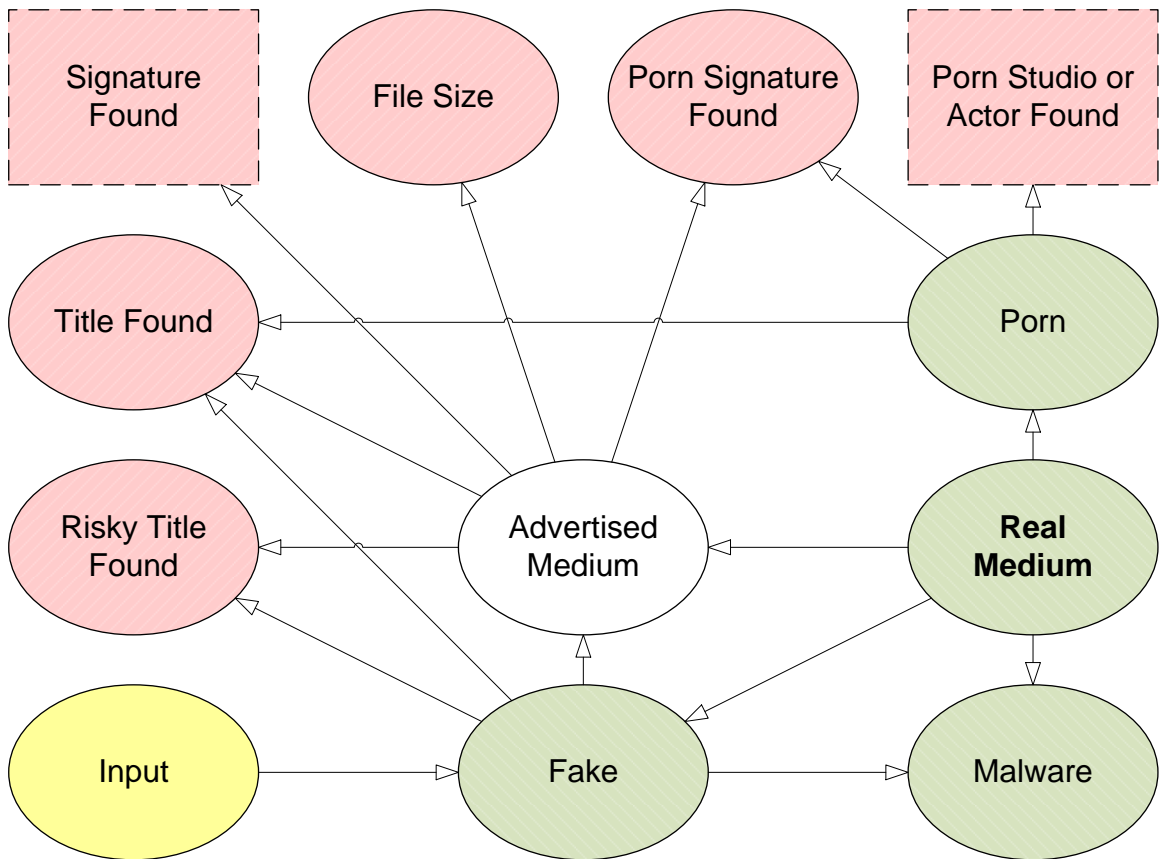

Figure 32: Basic Overview of the Current Model

Over multiple iterations of the model throughout the lifespan of the project we arrived at the general structure shown in Figure 32. Note that multiple nodes are combined behind nodes with rectangular dashed border for diagram simplicity (the rectangular nodes can be thought of as BN objects). The core concept is that the torrent type, also called ‘medium’, dictates other properties of the file. However, as we may not directly observe the actual medium or other properties; we have to predict them based on the declared file size and evidence encoded in the torrent name string by its poster. It is important to distinguish actual and advertised properties because some torrents have a description that is deceptive and does not correspond to their actual contents.

One of the primary objectives of this thesis was to develop a coherent framework to produce reliable predictions about the content of torrent downloads. We

identified the following attributes that are normally not directly observable and that we therefore seek to predict (coloured green in Figure 32):

- Primary medium of the download e.g. *music, movie, game* etc.
- Whether the item is porn
- Whether the item is a fake
- Whether the item contains malware

These predictions are based on evidence, entered as observations, for nodes that are directly observable (coloured pink in Figure 32). These include:

- File size
- Medium signatures
- Porn signatures
- Porn actor and studio names
- Movie, TV series and game titles
- ‘Risk group’ titles

Each of the above is explained in their own sections in this chapter.

### 3.5. Real Medium

In the early conceptualisation stage MovieLabs supplied us with their estimation of possible medium distribution of super categories, as shown in Table 23.

<b>Medium Category</b>	<b>Proportion</b>
Audio	16
Image	6
Software	8
Text	10
Video	60

Table 23: Original Medium Category Proportions Estimated by MovieLabs

We adopted our two-level taxonomy at a later stage and then needed to extend MovieLabs priors to the relevant subcategories.

We used human classifiers’ votes on DS2500 to get rough proportions of sub-categories within their super categories ( $H$  column in Table 24). In some cases the human classifiers were not always sure or disagreed about an item’s classification. Although they were instructed to select the category they felt was most probable, in some cases they chose only a super category or the “unknown” option.

According to feedback from MovieLabs on these proportion figures, we adjusted some of them ( $H_A$  column in Table 24). For example, we redistributed weight from movies and music towards other video and audio sub-categories, accordingly. Books, on the other hand, gained weight.

<b>Super Category</b>	<b>Sub-Category</b>	<b><math>H</math></b>	<b><math>H_A</math></b>
Audio	Audio: Music	0.92	0.83
	Audio: OST	0.03	0.05
	Audio: Other	0.06	0.12
Image	Image	1.00	1.00
Software	Software: Game	0.30	0.30
	Software: Other	0.70	0.70
Text	Text: Book	0.75	0.90
	Text: Magazine	0.20	0.08
	Text: Other	0.05	0.02
Video	Video: Movie	0.45	0.34
	Video: Other	0.25	0.30
	Video: TV	0.30	0.36

Table 24: Proportions of Sub-Categories Provided by Humans and Amended by MovieLabs

At a much later point we inserted the “Mixed” category into the taxonomy. The resulting figures were rounded to 3 significant figures to accommodate probabilities as low as 0.001 for “Mixed”. The resulting distribution can be found in Table 25.

<i>Real Medium</i>	<b>Audio: Music</b>	0.132
	<b>Audio: OST</b>	0.008
	<b>Audio: Other</b>	0.016
	<b>Image</b>	0.058
	<b>Mixed</b>	0.001
	<b>Software: Game</b>	0.025
	<b>Software: Other</b>	0.058
	<b>Text: Book</b>	0.090
	<b>Text: Magazine</b>	0.008
	<b>Text: Other</b>	0.001
	<b>Video: Movie</b>	0.206
	<b>Video: Other</b>	0.182
	<b>Video: TV</b>	0.215

Table 25: NPT for *Real Medium* in Current Model

The NPT table for *Real Medium* is very simple because it is a root node. Ultimately, it expresses our prior belief in the distribution of various categories of medium among the downloadable torrent files.

### 3.6. Fakes and Malware

A study in (Cuevas et al. 2010) reveals that 30% of supplied and 25% of downloaded content could be classified as fake items in 2010. Note that we focus primarily on fakes mimicking movies that are either anticipated or running in movie theatres. The actual content of the fakes may be either broken videos or malware. These observations are in line with information provided to us by MovieLabs and with our own analysis of the DSFM and DS120 samples. We also, however, consider the possibility for games, software and TVs to be faked. We can draw a chain of relations between the events ‘movie title match in file name’, ‘title of interest’, ‘fake’ and ‘malware’ where various risks must be assessed. It can also happen that a file name contains a movie title, but ends with an executable software extension such as ‘exe’, which also highlights a high risk of malware.

As discussed in Chapter 2, we define a fake as a torrent that is created not for the purpose of sharing the desired original content, but to mislead the public. For example, it could be named as an upcoming movie and contain a broken video, or a bait video with instructions to download a ‘codec’ from a suspicious web address, which actually turns out to be malware.

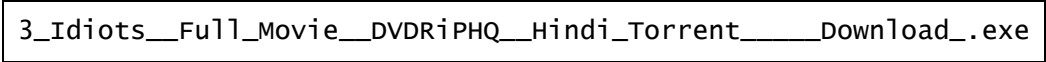

```
3_Idiots__Full_Movie__DVDRiPHQ__Hindi_Torrent____Download_.exe
```

Figure 33: Example of a Fake Torrent

The item in Figure 33 illustrates a simple fake torrent, which has a movie title (‘3 Idiots’) in the name string and claims to contain a movie ripped from a DVD. However, it also has some evidence in the name string that indicates that it actually might contain an executable rather than a video file. In theory, it could be software that would download the actual movie, but most likely it is malware, trying to fool an unwary user into launching this potentially malicious runnable file. In our study of newly posted torrent files we observed multiple items similar to this example, and all of them were malware.

In addition to the research in (Cuevas et al. 2010), which attempts to study the intentions of those who post torrent content online, we conducted a small study of our own. It was supposed to confirm or refine the prior expectation of fakes and malware among downloadable torrent files, and confirm or disprove the original statement that MovieLabs shared with us that a third of items that look like porn are, in fact, malware. In this experiment we downloaded 211 items from a single stream of newly posted torrents that looked like they contain porn, or upcoming or recently released movies. We then verified the contents of the items, which are summarised in Table 26, where *U* denotes upcoming titles, *T* refers to movies running in theatres, and *R* refers to movies that were released within 3 months from the date of the study, and not running in theatres any more.

	Looks Like			
	Porn	<i>U</i>	<i>T</i>	<i>R</i>
<b>Total</b>	<b>106</b>	<b>4</b>	<b>63</b>	<b>38</b>
Fake	3	4	33	2
Malware	1	2	20	2
Advertisement	11	1	15	1
None of the above	92	0	24	22

Table 26: Fakes & Malware Preliminary Study Summary

The groups ‘Fake’, ‘Malware’ and ‘Advertisement’ are not mutually exclusive in this table. We noticed that many torrents contained text files and web links that promoted torrent tracker websites or contained other advertising. Note that upcoming titles and those currently running in theatres are the most at risk of being fake. Additionally, out of all 42 fake items, 25 were malware, and the rest were broken or irrelevant videos. This small study provides us with a basis for drawing general relationships between porn, fakes, malware and titles that are most at risk.

The BN fragment of the current model illustrated by Figure 34 demonstrates the core mechanism for detecting fakes and malware. *Input* is a simple switch node that allows to choose a different prior for fakes depending on the collection of items being analysed. In our case two modes were relevant – ‘newly posted files’ and ‘old files’ – with the relevant observation set automatically depending on the mode selected by a human operator prior to running a classification task on a batch of items. This BN fragment presents a simple instantiation of the cause-consequence idiom from Section 3.3.5.

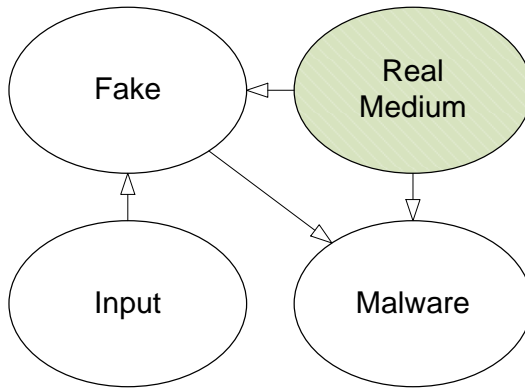

Figure 34: Model Fragment – Real Medium, Input, Fake, Malware

We define the NPT for *Fake* in Table 27, based on expert feedback from MovieLabs and our own study summarised in Table 26. Note that by default we use a very small number for True e.g. 0.0001, and only columns with non-default values are shown.

	<i>Input</i>	New Files					Old Files					
	<i>Real Medium</i>	Mixed	Software: Other	Video: Movie	Video: Other	Video: TV	Mixed	Software: Game	Software: Other	Video: Movie	Video: Other	Video: TV
<i>Fake</i>	<b>False</b>	0.9	0.4	0.999	0.7	0.999	0.999	0.999	0.99	0.999	0.99	0.999
	<b>True</b>	0.1	0.6	0.001	0.3	0.001	0.001	0.001	0.01	0.001	0.01	0.001

Table 27: NPT Fragment for *Fake* in Current Model

Table 27 captures the knowledge that old files generally pose a much lower risk of fakes, yet we still identify that it is mostly items in “Software: Other” and “Video: Other” categories that may be deceiving. Other categories such as “Software: Game”, “Video: Movie”, “Video: TV” and “Mixed” are assumed to also have a small chance of being a fake. On the other hand, for new files there is a much higher chance of fakes originating in “Software: Other” and “Video: Other” categories, e.g. because a torrent bearing a name of a relevant popular movie actually contains a broken video or malware.

Many users are very likely to remove an item they discover to be fake from their machine, which makes most fake items rather short-lived and means that there



may be torrents containing fakes that did not circulate in the network long enough to be even picked up by the MovieLabs system.

	<i>Fake</i>	<b>False</b>			<b>True</b>		
	<i>Real Medium</i>	Mixed	Software: Game	Software: Other	Mixed	Software: Game	Software: Other
<i>Malware</i>	<b>False</b>	0.9999	0.9999	0.9999	0.4	0.1	0.05
	<b>True</b>	0.0001	0.0001	0.0001	0.6	0.9	0.95

Table 28: NPT Fragment for *Malware* in Current Model

The NPT for *Malware* is defined as in Table 28 and is based on expert feedback from MovieLabs and our own study summarised in Table 26. Note that by default we use a zero probability for True, and only columns with non-default values are shown. This effectively means that we assume that malware can only be software, and those torrents that contain other types of files mixed with software. We decided to use this assumption to avoid unnecessary complexity of the model, even though there is technically a non-zero (but very low) probability that other types of media may be infected. Normally we assume that software, when it is not a fake, still has a very low probability of containing malware, for example due to sharing infected software that is otherwise legitimate. However, if the software is a fake, then chances of malware become very high, but not a complete certainty, because sometimes it may just be a faulty or harmless computer program.

### 3.7. Advertised Medium

*Advertised Medium* is the key to interpretation of the evidence we can gather. The essence of this concept is that declared file size and the posted name may not describe the actual content of the torrent. Normally, we assume that a non-fake item is most likely to be described in a meaningful way that reflects its actual contents (i.e. advertised medium is the same as real medium), while a fake will attempt to look like something else (i.e. advertised medium is different from real medium).

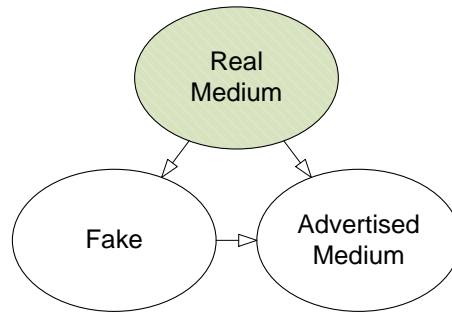

Figure 35: Current Model Fragment – Real Medium, Fake, Advertised Medium

Figure 35 demonstrates the relevant fragment from the model. The relationship between *Real Medium* and *Fake* defines which categories can or are expected to be fakes, and the node *Advertised Medium* specifies how the appearance of items can be affected if they were fakes according to the NPT fragment in Table 30. An item that is not fake has its medium simply translated from ‘real’ to ‘advertised’ as illustrated by the NPT fragment in Table 29. Note that only a subset of the categories are displayed.

		<i>Fake</i>	False			
		<i>Real Medium</i>	Audio: Music	Software: Other	Text: Magazine	Video: Movie
<i>Advertised Medium</i>	Audio: Music	1	0	0	0	
	Software: Other	0	1	0	0	
	Text: Magazine	0	0	1	0	
	Video: Movie	0	0	0	1	

Table 29: NPT Fragment for *Advertised Medium* in Current Model (Not Fake)

The purpose of the NPT fragment in Table 30 is to map the real medium of a fake to its advertised medium, allowing us to express the relationship between each pair of real and advertised categories. Note that the values shown are prior to normalisation and each value in every column is then proportionally scaled, such that all values in a column add up to 1 (this is done automatically in AgenaRisk). Assume that omitted cells contain a value of 1. The numbers in this table are based on consultations with MovieLabs experts.

		<i>Fake</i>	<b>True</b>				
		<i>Real Medium</i>	<b>Audio: Music</b>	<b>Mixed</b>	<b>Software: Other</b>	<b>Video: Movie</b>	<b>Video: Other</b>
<i>Advertised Medium</i>	<b>Audio: Music</b>	1000	1	1	1	1	
	<b>Mixed</b>	1	700	1	1	1	
	<b>Software: Game</b>	1	50	350	1	1	
	<b>Software: Other</b>	1	50	450	1	1	
	<b>Video: Movie</b>	1	100	400	1000	600	
	<b>Video: Other</b>	1	1	50	10	100	
	<b>Video: TV</b>	1	1	50	1	50	

Table 30: NPT Fragment for *Advertised Medium* in Current Model when Fake is True (non-normalised probabilities)

The motivation behind the figures in Table 30 is that “Mixed” category items, when being fake, might be advertised as software, or they can be a real movie file accompanied with an executable malware file. The column for “Software: Other” suggests that fakes coming from this category will mostly be presented as applications, games or movies. It is a rare case that movies themselves may be fakes, but sometimes users post a porn movie and name it as a recent blockbuster. We also observe cases where a movie would be posted with a cryptic name, suggesting that there is a private catalogue that maps these cryptic names to the actual movie titles, available to users of a particular sharing service. A possible reason for this is to avoid detection by anti-piracy agents.

From Figure 36a we note that there are very few fake items compared to the total population size. When an item is not fake, the posterior medium distribution is maintained across all categories except for a small fluctuation in “Video: Movie” and “Software: Other”, because these two categories are most affected by fakes.

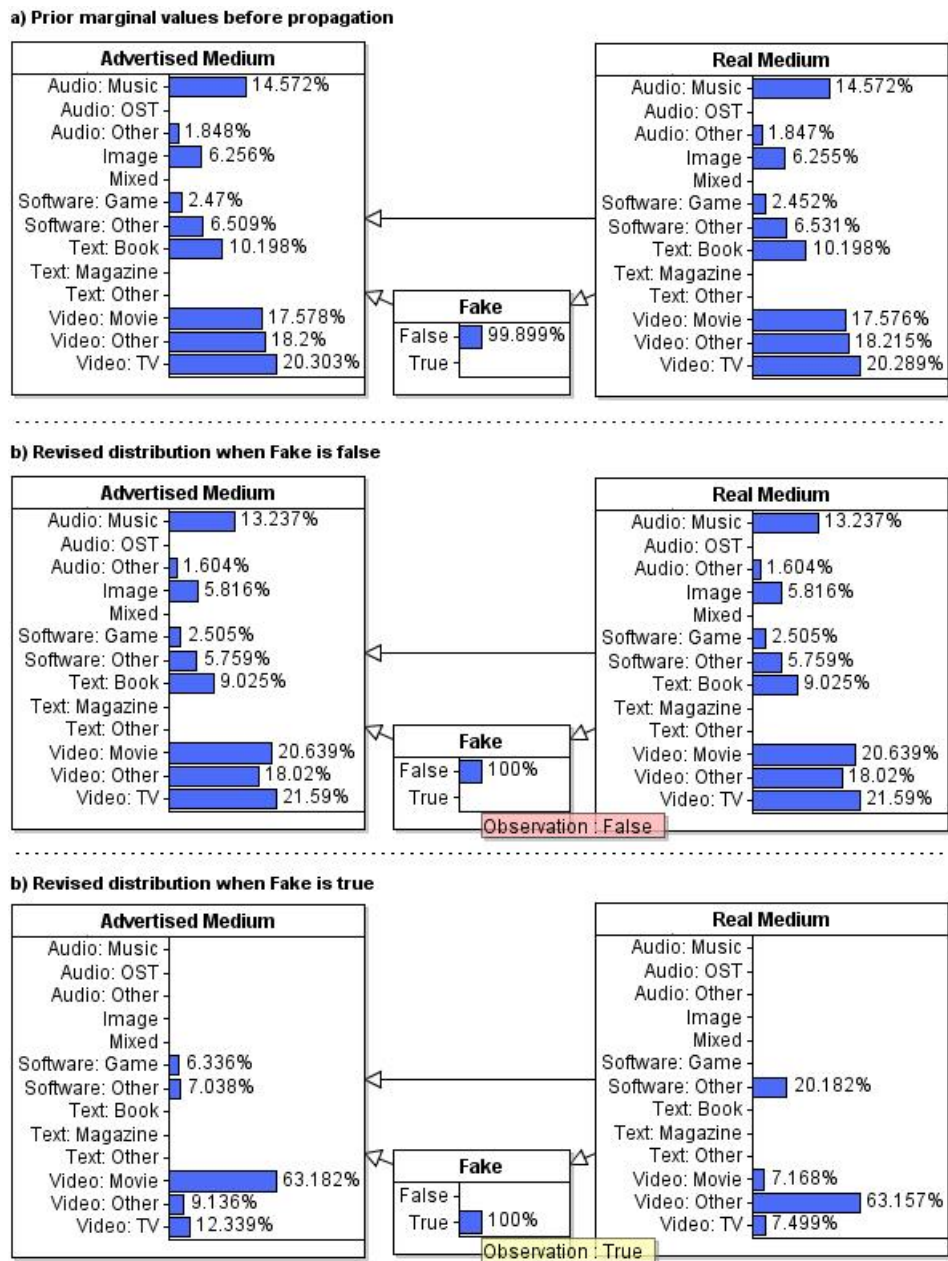

Figure 36: Relationship between *Fake*, *Real Medium* and *Advertised Medium*

When *Fake* is set to “True”, *Advertised Medium* shows categories that the fakes mimic, while *Real Medium* shows real categories of the fakes. Note that a small proportion of fakes may still originate from “Video: Movie” and “Video: TV” probably due to mistakes or intentional obfuscation in the name.

The most significant and practical implication of this section for the current model is the ability to handle cases when an item looks like a “Video: Movie”, but we find

some evidence that it may be a fake, and therefore change our posterior belief about real medium to be “Video: Other” or “Software: Other” instead.

### 3.8. File Size

File size is a very significant piece of evidence, since it is indicative of the torrent’s content even without much meaningful evidence in the name string. However, a deep analysis of the relationship between file size and medium categories was required before we could use this data. The NPT for *File Size* is ultimately based on DS2500. See Figure F.1 and Table F.1 for the original data supplied by experts. We define 33 discrete ranges that increase in interval size according to their order of magnitude as shown in Table 31. For example, a file of size 907MB will fall into the range “900 to 1,000” while a file of size 4,500MB will fall into the range “4,000 to 5,000”.

<b>File Size (MB)</b>	<b>Range Size (MB)</b>
0 to 100	10
100 to 1,000	100
1,000 to 10,000	1,000
10,000 to 50,000	10,000
Over 50,000	$\infty$

Table 31: File Size Ranges

The primary reasoning for such a discretisation of ranges is that there is more diversity in the lower end of the spectrum – more than 50% of files in the sample fall below 500MB and more than 70% of files fall below 1,000MB.

Ideally *File Size* should be defined as a continuous-type node within the modelling software with a multi-modal distribution for each parent’s state. However, due to difficulties in learning the necessary distributions and their parameters we decided to discretise this node and plot smoothed distributions manually. The multi-modal nature of file size distributions lies with potential granularity of some

categories according to their orthogonal properties. For example, we observe that movies cluster around 2GB for regular movies and 8GB for high definition movies.

We constructed the NPT for the *File Size* node, motivated by the original data (see Figure 37; frequency per range is y-axis, ranges are x-axis), avoiding data artefacts like zeros and sudden spikes. In some cases our derived distributions do not follow the data completely due to not having observed sufficient numbers of items of every category. For 5 of 13 categories with total count less than 1% of all items in DS2500, we manually defined distributions based on expert-confirmed assumptions.

For example, “Audio: OST” (original soundtrack) comprised less than 0.5% of the studied sample, which significantly lowers the reliability of such data. In case of “Audio: OST”, we made an assumption that it is more likely for somebody to share a complete soundtrack for an item such as a movie, for which a reasonable size may be under 200MB. As indicated in the Future Work Section 7.3, a separate study of the file size alone would benefit the overall model.

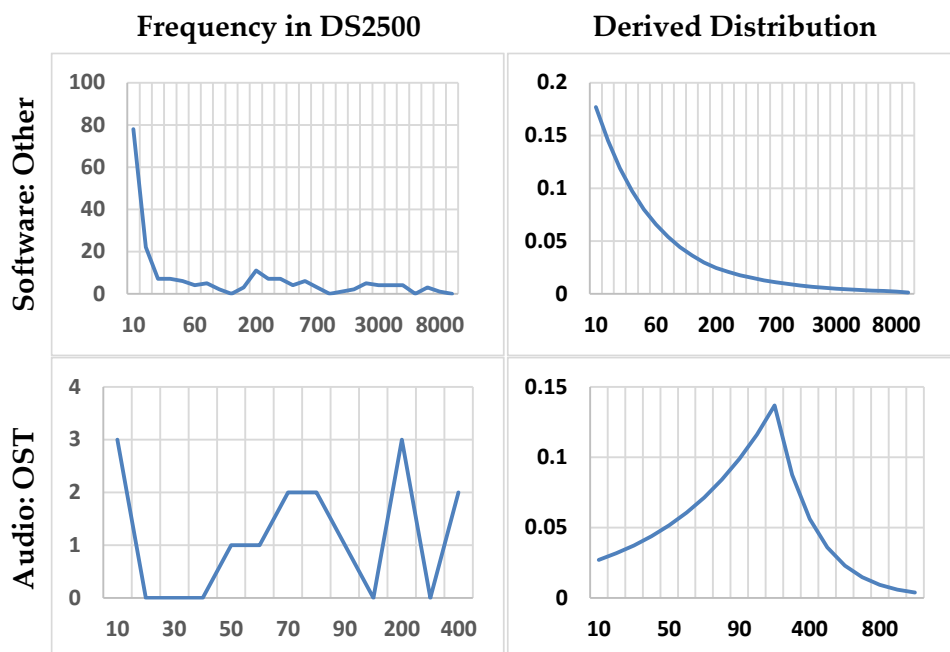

Figure 37: Example of File Size Distributions

Essentially, evidence connected to *Real Medium* would have a higher impact on the final predictions than the evidence connected to *Advertised Medium* due to relation to *Fake*, which was explained in Section 3.6. Therefore we decided to connect the *File Size* node to *Advertised Medium* in the absence of a complete expert understanding of how file size was related to different types of media at all size ranges. It is important to note that many fakes also mimic file size. For example, a broken video bearing a name of a popular movie could play for only several seconds, but still have the size that a decent movie video file is expected to have, which indicates that file size is yet another attribute of the torrent appearance and should not be directly connected to *Real Medium*. The final NPT and accompanying graphs for each medium category are available in Appendix Table F.2 and Appendix Figure F.2 respectively.

### 3.9. Signatures

The original expertise provided to us by MovieLabs revolved around the idea of keywords, which could be detected as substrings in a file name and subsequently associated with a medium category. We re-defined this approach in terms of signatures, which are the primary piece of evidence found in the torrent name strings, and consider whether the name string contains:

- Specific medium category evidence
- Mention of a language
- Subtitles info
- Date
- Year

For the purpose of the BN model in the project, a signature is evidence found in the torrent name that is associated with a particular medium category and has a strength value for this association. Section 4.1 explains the process of extracting evidence to be used for the BN model as observations, and how signatures are

defined in terms of text strings, patterns and strength of category associations. There are several special types of evidence such as date, subtitles, year and language that are similar to the regular category signatures. Each medium sub-category has its own node, e.g. as illustrated by the BN fragment in Figure 38. This allows us to specify that there is a chance to detect a signature for a particular advertised medium category when the item actually belongs some real medium category.

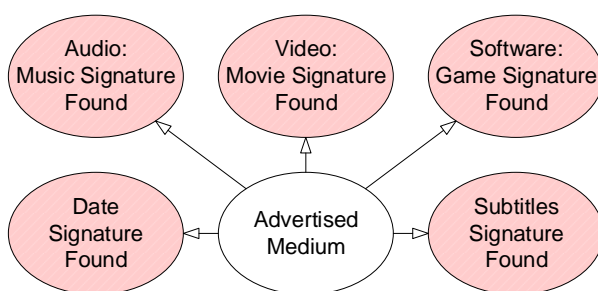

Figure 38: Current Model Fragment – Advertised Medium and Several Signature Nodes

Consider, for example, the torrent name from Table 32. While it has a number of general video and movie-specific attributes, it also contains information about the audio channel. This means that we can expect to observe some audio signatures in a file name that ultimately describes a video file (see Appendix Figure G.1 for a BN illustration).

Before.Sunset.2004.DVDRip.x264.aac.mkv	
Before Sunset	Movie title
2004	Movie release year
DVDRip	Video source
x264	Video encoding
mkv	File extension
aac	Audio compression

Table 32: Movie Torrent Example with Audio Signature

Another type of behaviour modelled is that the same bit of information may refer to files of different type. For example, a date in a file name may indicate that it is either a radio recording (i.e. “audio”), or a record of a TV programme (i.e. “video”) as demonstrated by Appendix Figure G.2.



Some signatures may have to be able to overpower other evidence. For example, a file name may have a number of strong clues that the item is a movie (e.g. as in Appendix Figure G.3), but a simple inclusion of 'OST' in the name may almost definitively indicate that it is, in fact, only soundtrack (e.g. as in Appendix Figure G.4) and not the actual movie. Of course, file size would also be different for both these examples and has to be taken into account. However, even without file size evidence, the posterior belief will shift towards soundtrack after observing relevant evidence as shown in Appendix Figure G.5. Note that detecting both soundtrack and movie signatures may also refer to a mixed torrent that contains both the movie and the soundtrack, so a decision rule approach here is not a completely suitable option.

### 3.9.1. Regular Signature Node NPTs

In the early iterations of the model we used Boolean nodes to model evidence for a particular category. However, the necessity to specify the amount (or strength) of evidence for a particular category soon became apparent. The current model uses a positive numeric value for the strength of detected signatures. Apart from state 0 which simply means that nothing was found, there are 19 more states up to 2 in increments of 0.1, and the last state is from 2 to infinity. Effectively, the value of 2 is a cap we placed to make the NPTs for signature nodes more practical. In reality very few items will reach the cap for more multiple categories at once. For example, an item with over 2 signature strength for "Video: Movie" is very unlikely to also reach over 2 for another category.

The underlying probability distribution for every signature node must be inherently bimodal because the normal expectation should be ultimately high to find no evidence, e.g. prior probability for the 0 state is close to 1. However, the discovery of evidence should follow a logical progression. For example, the more

accurate the description of a movie torrent, the higher the signature score for “Video: Movie”.

The manner of discretisation of the regular signature nodes means that they each have a 21 by 13 NPT. Our approach for defining conditional probabilities for signature nodes is based on the notion of related medium categories. For example, “Video: TV” category is related to “Video: Movie” closer, as opposed to “Text: Book”, because there are some signatures shared between movie and TV torrents, such as HDTV RIP, which refers to the video being ripped from HDTV source. It is also of interest that the same signature may not be relevant for all sub-categories within one category, e.g. x264 is not used for “Video: Other” but possible for “Video: Movie” or “Video: TV”.

```
Sony.Vegas.Movie.Studio.Platinum.Edition.v.8.0d.build.139.2008.PC
```

Figure 39: Video Editing Software Torrent with Weak Movie Signature

Note that evidence associations between categories are not necessarily reversible, for example, weak movie evidence may contribute toward “Software: Other”, but not the other way around. This case may be illustrated by a torrent containing video processing software such as the example in Figure 39.

The crucial point about associations between categories lies in the ability to capture the following behaviour:

- An item that belongs to a category  $A$  is expected to have strong evidence associated with  $A$  in the name string.
- Presence of weak evidence associated with category  $A$  may contribute to our belief that the item actually belongs to a different category  $B$ .

A simple example to illustrate this was presented in Table 32. Such a torrent contains strong cumulative evidence for “Video: Movie” and weak evidence for “Audio”, which in this case must contribute to our belief that the actual sub-

category is “Video: Movie”. In essence, a movie torrent is more likely to have very strong movie evidence and may have some weak audio evidence.

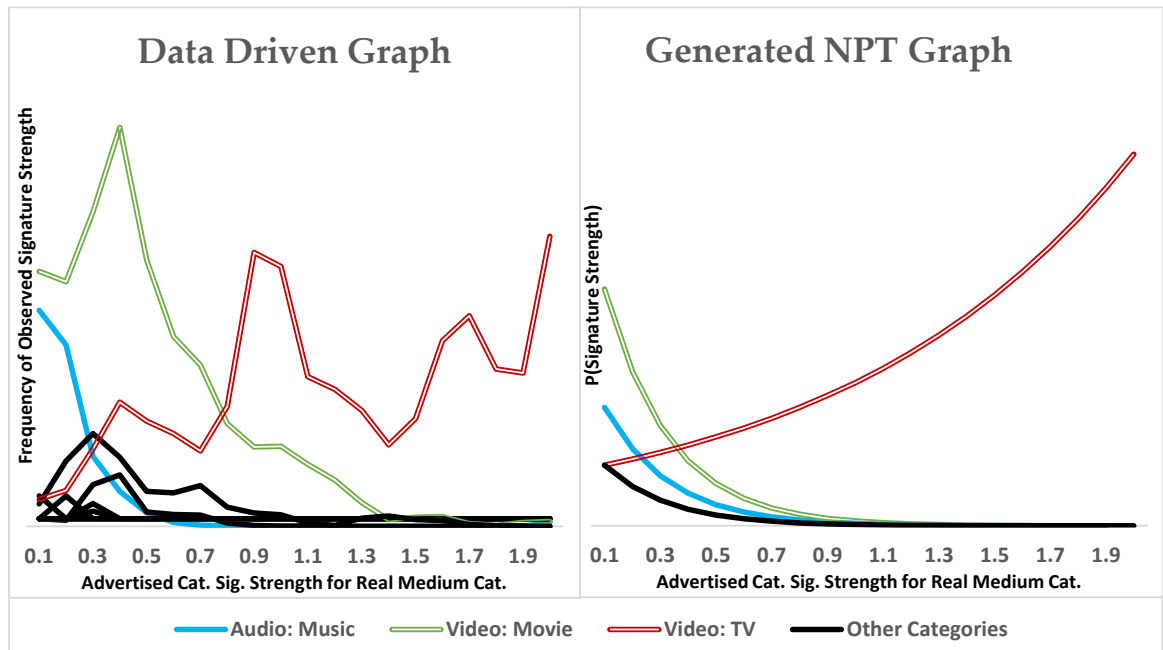

Figure 40: *Video: TV Signature Detected* NPT Graphs (Driven by Original Data and Generated)

Figure 40 demonstrates the original data motivating the NPT for *Video: TV Signature Detected* node as well as our projected interpretation of this data. The x-axis is the signature strength of advertised medium categories found in a torrent of a particular real medium category (e.g. “Video: TV” in this graph). The y-axis of the leftmost graph is the frequencies with which each signature strength value was observed in the data for “Video: TV”, while y-axis in the rightmost graph is the expected probability of observing signature strengths. The actual numbers on the y-axis are not important as we are mostly concerned with trends and proportions here.

Note that we deliberately reduce sensitivity to finding no evidence by setting the first row in each NPT column to a very large number, which enforces little posterior effect when the node is instantiated to 0 evidence. Therefore, the first data point in the graph on the right is omitted. Parameters for the distributions were informed in part by expert knowledge provided by MovieLabs, and supplemented by analysis of the DS2500 data sample.

Every medium category corresponds to a column in the NPT and, except for the first row, features a distribution with a geometric progression based on parameters  $T$  (i.e. starting point) and  $M$  (i.e. multiplier), which are determined according to Tables 33 and 34. We identified several levels of category relationships as seen in Table 33. Refer to the short sub-category names in Table 4.

		Association from Category $c$											
		Audio: Music	Audio: OST	Audio: Other	Image	Software: Game	Software: Other	Text: Book	Text: Magazine	Text: Other	Video: Movie	Video: Other	Video: TV
Signature Found for Category $C_E$	Audio: Music	1					W				S		W
	Audio: OST	S	1										
	Audio: Other	S		1									
	Image				1								S
	Software: Game					1					S		S
	Software: Other	W			W		1						S
	Text: Book				W		S	1	W				
	Text: Magazine						S		1				
	Text: Other							S		1			
	Video: Movie	W					W				1	S	S
	Video: Other										S	1	W
	Video: TV	W									S		1

Table 33: Associations between Medium Categories

Table 33 outlines how much evidence associated with a category  $C_E$  will contribute to believing that the item actually belongs to a category  $c$ , and assumes the following legend:

- 1: category  $c$  is the same as  $C_E$
- S: weak evidence associated with  $C_E$  strongly contributes to  $c$
- W: weak evidence associated with  $C_E$  weakly contributes to  $c$

Table 34 provides definitions of  $T$  and  $M$  which are passed as parameters to Algorithm 1 below.

Association	$T$	$M$
1	1.0	1.10
S	6.0	0.65
W	3.0	0.65
(default)	2.0	0.65

Table 34: Mapping for  $T$  and  $M$  from Table 33

Each column of a signature node NPT is defined according to the Algorithm 1, which takes parameters  $T$  and  $M$ , the list of column rows  $R$  and uses an arbitrarily large constant e.g. 3,000 as the value for the first row before normalisation.

```

// Parameters: starting value  $T$ , multiplier  $M$ , rows  $R$ 
// Initialise cell value  $E$ 
 $E = T$ 
for each  $r \in R$  do {
    // Set the row cell  $E_r$ 
     $E_r = E$ 
     $E = E \times M$ 
}
// Set the zero row cell to a sufficiently big number
// to represent prior belief in zero evidence
 $E_0 = 3000$ 
// Normalise column by invoking Algorithm 2
NORMALISE( $R$ )

```

Algorithm 1: Generate Column for *Signature Found* NPT

The normalisation procedure simply weights all values in the column according to Algorithm 2, such that they add up to 1 and are effectively probabilities. Algorithm 2 takes as a parameter the list of column rows  $R$ . We assume here that the sum of values in the whole column is not equal to 0.

```

// Parameters: rows  $R$ 
// Initialise column sum  $S$ 
 $S = 0$ 
for each  $r \in R$  do {
    // Row cell  $E_r$ 
     $S = S + E_r$ 
}
for each  $r \in R$  do {
    // Row cell  $E_r$ 
     $E_r = E_r / S$ 
}

```

Algorithm 2: NPT Normalisation

The following example considers generating values for the NPT in *Video: TV Signature Found* node, column “Audio: Music”. According to Tables 33 and 34,  $C_E$  is “Video: TV”,  $c$  is “Audio: Music”, parameters  $T$  and  $M$  are 3.0 and 0.65 respectively. A relevant scenario is when we find weak TV evidence e.g. ‘Part 1’, and the desired outcome here is for this evidence to contribute to the belief that the item actually is “Audio: Music” on the assumption that a real TV would have a much stronger TV evidence.

Column Generated by Algorithm 1	Final Column Normalised with Algorithm 2
3000 (initially 3.0)	0.998147
1.95	0.000649
1.2675	0.000422
0.823875	0.000274
0.535519	0.000178
0.348087	0.000116
0.226257	7.53E-05
0.147067	4.89E-05
0.095593	3.18E-05
0.062136	2.07E-05
0.040388	1.34E-05
0.026252	8.73E-06
0.017064	5.68E-06
0.011092	3.69E-06
0.00721	2.4E-06
0.004686	1.56E-06
0.003046	1.01E-06
0.00198	6.59E-07
0.001287	4.28E-07
0.000837	2.78E-07

Table 35: Generating Signature NPT Column Example

Table 35 shows how Algorithm 1 starts with setting the zero row to  $T$  then fills the column down multiplying the previous value by  $M$ , and then sets the zero row to an arbitrarily high number e.g. 3000. Then Algorithm 2 normalises the column such that all values become probabilities and add up to 1. The large number in zero row is used to make sure that not finding any evidence does not have a big impact on the posterior belief. We decided to use this approach in order to avoid situations where a signature, that Toran is not aware of, fails to be picked up and thus impacts the posterior belief in a wrong way.

### 3.9.2. Special Signature Node NPTs

While most signatures are based on generic patterns related to media types, extensions, commonly used keywords etc., there are particular signatures that could be combined into several groups:

- Date
- Year
- Subtitles
- Language

When considering NPTs of these nodes below, note that only significant columns are displayed, and all others can be assumed to have 0.999 in “false” or “none” as applicable, which is also true for Tables 37 and 38.

*Date Detected* is a very basic node and it captures whether a numeric date is contained in the torrent name. Its NPT is defined in Table 36. Most commonly we find dates to be used for videos in general and short videos in particular, as well as for music, images and software.

	<i>Advertised Medium</i>	<b>Audio: Music</b>	<b>Image</b>	<b>Software: Other</b>	<b>Video: Movie</b>	<b>Video: Other</b>	<b>Video: TV</b>
<i>Date</i>	<b>False</b>	0.997	0.997	0.997	0.997	0.99	0.995
	<b>True</b>	0.003	0.003	0.003	0.003	0.01	0.005

Table 36: NPT Fragment for *Date Detected*

*Year Detected* is also a basic node and captures whether the torrent name contains a year starting with 19 or 20, and its NPT is defined in Table 37. We can often find a mention of year in names of music and movie files, and less frequently in other videos, software and books.



	<i>Advertised Medium</i>	<b>Audio: Music</b>	<b>Software: Other</b>	<b>Text: Book</b>	<b>Video: Movie</b>	<b>Video: Other</b>	<b>Video: TV</b>
<i>Year</i>	<b>False</b>	0.98	0.99	0.99	0.98	0.99	0.99
	<b>True</b>	0.02	0.01	0.01	0.02	0.01	0.01

Table 37: NPT Fragment for *Year Detected*

*Subtitles Detected* is another binary evidence node and refers to whether the torrent name contains subtitles information. We find that the absolute majority of such items are movies or TV series, as illustrated by Table 38.

	<i>Advertised Medium</i>	<b>Video: Movie</b>	<b>Video: TV</b>
<i>Subtitles</i>	<b>False</b>	0.993	0.994
	<b>True</b>	0.007	0.006

Table 38: NPT Fragment for *Subtitles Detected*

Language is very often present in the names of video torrents, and to a lesser extent in software. The NPT for *Language Detected* was generated according to the procedure in Algorithm 1 with “Video: Movie”, “Video: TV” and “Video: Other” as increasing columns with  $T = 1.0$  and  $M = 1.1$ , “Software: Other” decreasing with  $T = 6.0$  and  $M = 0.65$  and all other categories decreasing with  $T = 2.0$  and  $M = 0.65$ , as is demonstrated by Figure 41.

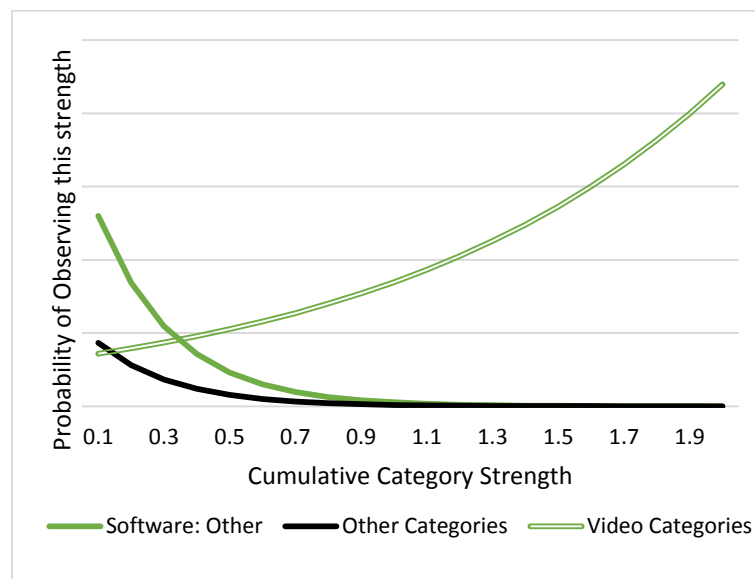

Figure 41: *Language Detected* NPT Graph

Note that the zero row is omitted and contains numbers close to 1 to express our prior belief of not detecting language in any torrents.

### 3.10. Porn Detection

A large number of torrents contain porn content (around 16% according to DS2500) and this can be captured with signatures that are specifically related to porn, and by checking whether the file name string contains some of the names of porn actors or studios. MovieLabs initially informed us that around a third of content that claimed to be porn, turned out to be malware. This assertion suggested that a BN to model this behaviour should look like that shown in Figure 42.

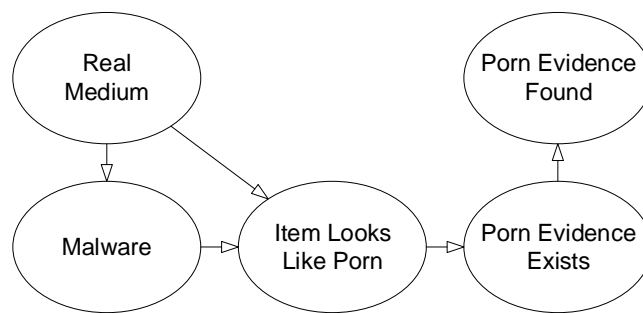

Figure 42: BN Fragment – Option for Modelling Porn and Malware

However, our own study of the data could not confirm this claim. Out of over a hundred items that looked like porn only one turned out to be malware (see Table 26), so we concluded that there was not a special relationship between porn and malware and that a possibility for malware could be modelled via fakes. We concentrated on trying to more accurately detect porn content by modelling it according to the BN fragment in Figure 43.

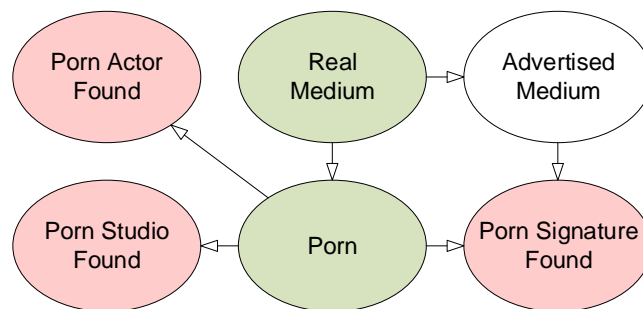

Figure 43: Current Model Fragment – Porn Detection

It is important that we can specify which types of media can actually contain porn and this is accommodated by the *Porn* node being a child of *Real Medium*, and the NPT is defined as in Table 39.

	<i>Real Medium</i>	Audio: Music	Audio: OST	Audio: Other	Image	Mixed	Software: Game	Software: Other	Text: Book	Text: Magazine	Text: Other	Video: Movie	Video: Other	Video: TV
<i>Porn</i>	False	1.0	1.0	1.0	0.5	0.9	0.99	0.99	0.95	0.9	1.0	0.8	0.4	0.99
	True	0.0	0.0	0.0	0.5	0.1	0.01	0.01	0.05	0.1	0.0	0.2	0.6	0.01

Table 39: NPT for *Porn*

The logic behind *Porn* NPT is that some media formats simply should not be considered porn, such as audio, while others have varying probability of containing adult material. Most porn is observed in a form of short videos and, to a lesser extent, full length movies that are often simply compilations of short unrelated videos.

The current model draws evidence from the following clues found in the torrent name, as illustrated by Figure 43:

- Porn signatures
- Names of porn actors
- Porn studios
- Titles for movies that are listed as adult

Actual Category	Torrent Name
Audio: Music	200069 - Sexy Trance - 07
Audio: Music	VA-Sex4yourears.Com_Presents-the_Ultimate_Sextape-2010-DjLeak
Video: Movie	Sex.Tape.[1080p].2014
Video: Other	Sexy Striptease (Vocal Trance).mp4
Video: Movie	The Girl Next Door.mkv

Table 40: Example – Torrents with Porn Signatures but Actually Not Porn

The node *Porn Signature Found* works similarly to other signature nodes covered in Section 3.9. However, one important difference is that we specify explicitly that porn keywords can be found for items that are not porn. See a number of examples in Table 40. Note that “Audio: Music” is not even a visual type of medium, yet it may be accompanied by porn keywords.

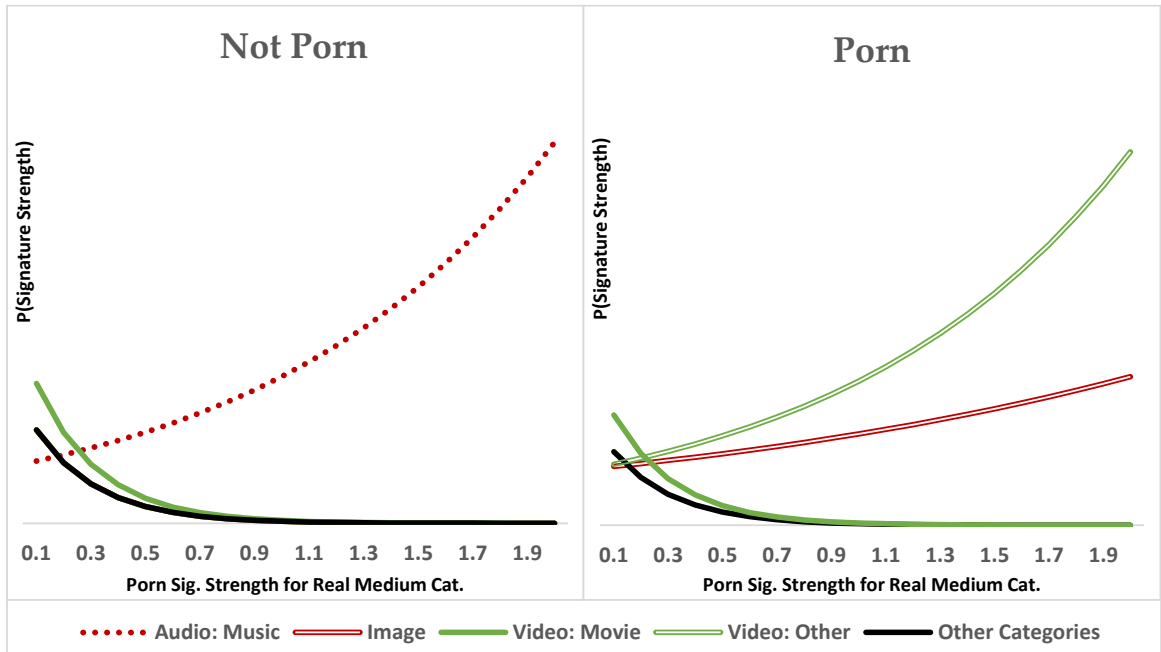

Figure 44: *Porn Signature Found* NPT Graphs

The NPT columns for *Porn Signature Found* are generated by the procedure explained in Algorithm 1, with the configuration in Table 41. When porn is false, “Audio: Music” is the increasing column and when porn is true, “Video: Other” and “Image” are the increasing columns. The resulting NPT (except the zero row) is illustrated by Figure 44. The x-axis is the porn signature strength of advertised medium categories found in a torrent of a particular real medium category when the torrent is actually porn or not. The y-axis is the expected probability of observing signature strengths. The actual numbers on the y-axis are not important as we are mostly concerned with trends and proportions here.

We assume that images generally do not get such an abundance of porn keywords as do videos, but images are the second most common source of porn. Note that

the graph on the right omits “Audio: Music” as it is now included in “Other Categories”.

	Category	<i>T</i>	<i>M</i>
<b>Not Porn</b>	Audio: Music	0.8	1.10
	Video: Movie	3.0	0.65
	Other Categories	2.0	0.65
<b>Porn</b>	Video: Other	1.0	1.10
	Image	1.0	1.05
	Video: Movie	3.0	0.65
	Other Categories	2.0	0.65

Table 41: *T* and *M* Parameters for *Porn Signature Found* NPT

The BN also supports the notion that in some cases items that may look like porn actually are not porn. For example, titles such as ‘Sexy Vol Trance’ may often be found in names of torrents that contain music. Note how “Audio: Music” is defined in Table 41 in such a way that it allows for strong porn evidence. This means that when only porn-related words are detected, the model still needs to take other factors like video or image evidence and file size into account.

In order to improve porn detection we expanded a short list of porn studios provided by MovieLabs and gathered more than 3,500 porn actors’ names. The detection mechanism here is binary and therefore the NPTs are rather simple, as illustrated by Tables 42 and 43.

	<i>Porn</i>	<b>False</b>	<b>True</b>
<i>Porn Studio Found</i>	<b>False</b>	0.9999	0.99
	<b>True</b>	0.0001	0.01

Table 42: NPT for *Porn Studio Found* in Current Model

The list of studios in our database is composed of rare combinations of words and characters, and was collected specifically to minimise false positives. However, it is a small list and we do not expect to often detect an entry from it.

	<i>Porn</i>	<b>False</b>	<b>True</b>
<i>Porn Actor Found</i>	<b>False</b>	0.999	0.88
	<b>True</b>	0.001	0.12

Table 43: NPT for *Porn Actor Found* in Current Model

Similarly, we only picked actors' names for which we were confident false positives could be avoided, at the cost of the list being not nearly exhaustive. However, when there is a match, it should act as strong evidence in favour of porn. More details about detecting names and studios can be found in Section 4.3.

The final piece of evidence relevant for porn detection is being able to match the torrent name to a title of a known adult movie. Title detection is more generally covered in Section 3.11.

### 3.11. Title Detection

Based on manually processing 2500 items, we estimate that 99% of movies, games and TV series torrents contain the item's title in the torrent name. However, out of these 99% items only 22% contain a title in its original release form while others contain an official alternative (e.g. translated), obfuscated or unofficial title or shorthand. We collected a number of official titles from IMDb as we explain in Section 2.4. Some items are pre-classified by IMDb as adult content. We use this distinction to improve porn detection by separating movies into two types of titles: 'movie not porn' and 'movie porn'.

An identification system can only get as good as its knowledge of the titles that it needs to identify, therefore database coverage is a very important factor in our estimation of identification expectations. It is important to note that a lot of content on the Internet is inherently something that would not appear on a formal database of titles. For example, somebody may film their cat performing a trick, and the video may become very popular; then someone would make a compilation of

similar videos and post them as a torrent. Such a torrent would not appear as a title in a database.

There is an additional difficulty in maintaining any kind of relevant database. For example, we could not use IMDb's data directly because a very large proportion of it was irrelevant and made title matching significantly longer and less accurate. New items must also be regularly added to the database, which means even higher maintenance costs. This is one of the reasons we decided to use title matching as a secondary source of evidence.

Please refer to the model overview BN in Figure 32 for the structure relevant to title identification. The node *Found in DB* specifies that it is very unlikely for an item to be a fake and porn at the same time, however, real fakes are likely to mimic movies specifically. When an item is not a fake, we expect to capture few titles by putting a strong prior for "None".

When an item is not fake or porn, we expect to detect some titles in their relevant categories. The porn category is expected to come mainly as movies with fewer TVs and even fewer games. We also expect that some of the porn torrents may be identified as non-porn movies, and vice-versa. Primarily this is due to porn and non-porn movies being sometimes named the same way. For example, there are several thriller, drama and even horror movies named 'The Girl Next Door', as well as dozens of porn movies and shorts.

The NPT for *Found in DB* is defined as in Table 44. Note that the values shown are prior to normalisation and each value in every column is then proportionally scaled, such that all values in a column add up to 1. Assume that omitted columns contain a value of 1 in all rows except the top row, which contains an arbitrarily large number e.g. 3000.

		<i>Fake</i>			<b>False</b>			<b>True</b>					
		<i>Porn</i>			<b>False</b>		<b>True</b>		<b>False</b>		<b>True</b>		
		<i>Advertised Medium</i>			Software: Game	Video: Movie	Video: TV	Software: Game	Video: Movie	Video: TV	Software: Other	Video: Other	...
<b>Found in DB</b>	<b>None</b>	3000	3000	3000	3000	3000	3000	3000	3000	3000	3000	3000	3000
	<b>Game</b>	500	1	1	2	1	1	1	1	1	1	1	1
	<b>Movie Not Porn</b>	1	500	1	1	50	1	2000	2000	1	1	1	1
	<b>Movie Porn</b>	1	50	1	1	500	1	1	1	1	1	1	1
	<b>TV</b>	1	1	500	1	1	50	1	1	1	1	1	1

Table 44: NPT for *Found in DB* in Current Model (non-normalised probabilities)

The probability values of this NPT were primarily informed by the performance of Toran on the DS2500 sample. Note that we may also sometimes erroneously detect a title (e.g. a movie title found for an item that is a game). We also expect to often get a positive match to a correct title when the item is a TV or a movie. However, our database of game titles is underpopulated, so only around a third of game items may return a positive game title match.

[SKIDROW] Battleship. 2012. HQ. REPACK

Figure 45: Example of a Torrent Name with Multi-Category Title Match

The evidence for this node may be uncertain in cases where the detection mechanism returns multiple title matches of the same score in different categories. In these cases the observation is entered as virtual evidence as defined in Section 3.2.4. For example, the torrent name in Figure 45 would positively match to a movie ‘Battleship’ released in 2012, and its accompanying video game that has the same title and release year. In this case the evidence is entered as 0.5 for both “Movie Not Porn” and “Game” states (see Figure 46c, note that it is actually virtual evidence rather than soft). In contrast, should we only detect a match in a single category, we would enter hard evidence on one of those states (Figure 46b).



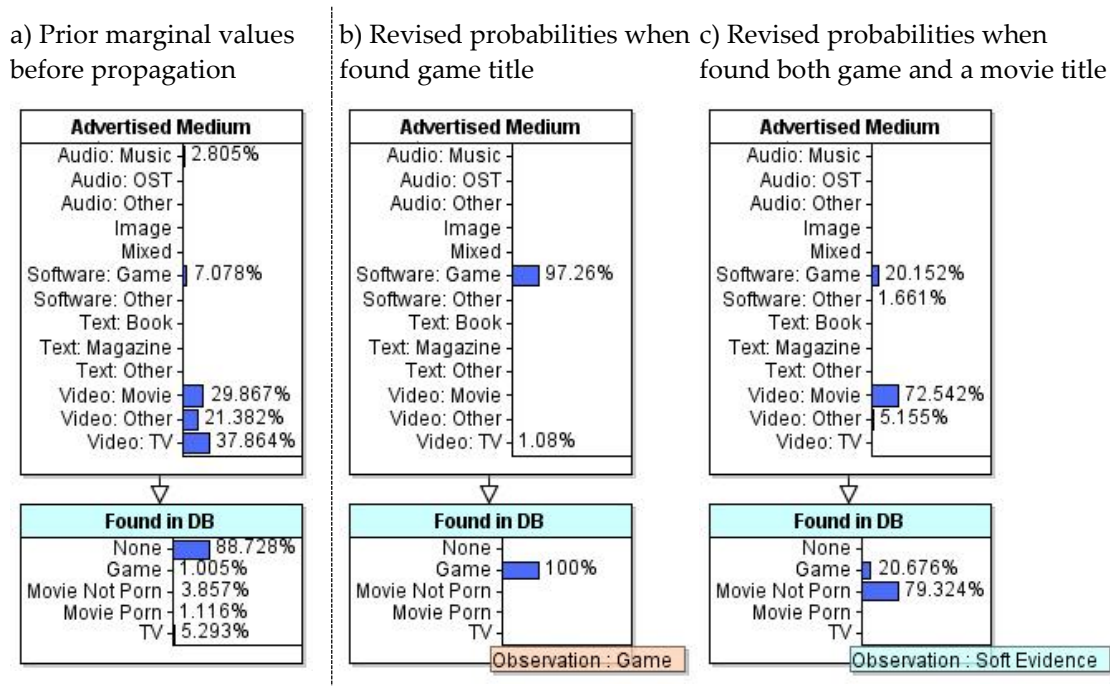

Figure 46: Title Detection Example - Current Model Fragment

For further details on the procedure for filtering the name string and capturing a title see Sections 4.3 and 4.4.

### 3.12. Risky Titles

As indicated in Section 1.1, upcoming, recently released or otherwise relevant movie titles are often aggressively protected by their owners, especially when they are Hollywood studios. Such movies are also often a target for hackers who post disguised malware. Before a movie is leaked or digitally released to the public in any other way (e.g. on DVD, Blu-ray, official web download etc.), its title should be listed in the 'risk group'. While we observe very few cases of downloads with illegal recordings made inside a cinema theatre, we do notice that after a movie is digitally released, it is always guaranteed to be available on the Internet, and may soon be moved from the 'risk group' to the general title database.

The node *Risky Title Found* describes the chances of an item being successfully matched to one of such titles depending on whether it is a fake, and on how it looks like.

	<i>Fake</i>	<b>False</b>			<b>True</b>			
	<i>Advertised Medium</i>	Mixed	Software: Game	Video: Movie	Mixed	Software: Game	Video: Movie	Video: TV
<i>Risky Title Found</i>	<b>False</b>	0.99	0.99	0.95	0.7	0.99	0.01	0.99
	<b>True</b>	0.01	0.01	0.05	0.3	0.01	0.99	0.01

Table 45: NPT for *Found Risky Title* in Current Model

The NPT for *Found in DB* is defined as in Table 45. Note that only significant columns of the NPT are shown, and for all other columns assume 0.9999 for the “False” row. This NPT is based on the expert knowledge supplied to us by the MovieLabs, our own study of newly posted torrents (see Table 26) and performance of our title matching mechanism. We suggest from the records we processed manually that among items that look like movies that currently are or recently were running in theatres, around 45% and 25% were fakes and malware, respectively.

It is important that even when an item is not a fake and is a movie or, to a lesser extent, game or mixed collection, it can match a title in the risk group (i.e. produce a false positive), because items may have different content based on the same title. For example, it is quite common for popular movies to be followed up by a video game based on the movie and sharing the same title. For example, at the time of its release in 2012 the movie ‘Battleship’ (2012) would have been considered a risky title, and it would very likely be detected in a torrent with the game ‘Battleship’ (2012), hence resulting in a false positive. Alternatively, there could be an old movie that has the same title as a more recent remake. A mixed collection could claim to include both.

Figure 47 shows two scenarios applicable to risky title detection. Note that for this figure there is strong evidence for the item to look like a movie, but this is omitted from the figure.

a) Item looks like a movie but does not contain a risky title

b) Item looks like a movie and contains a risky title

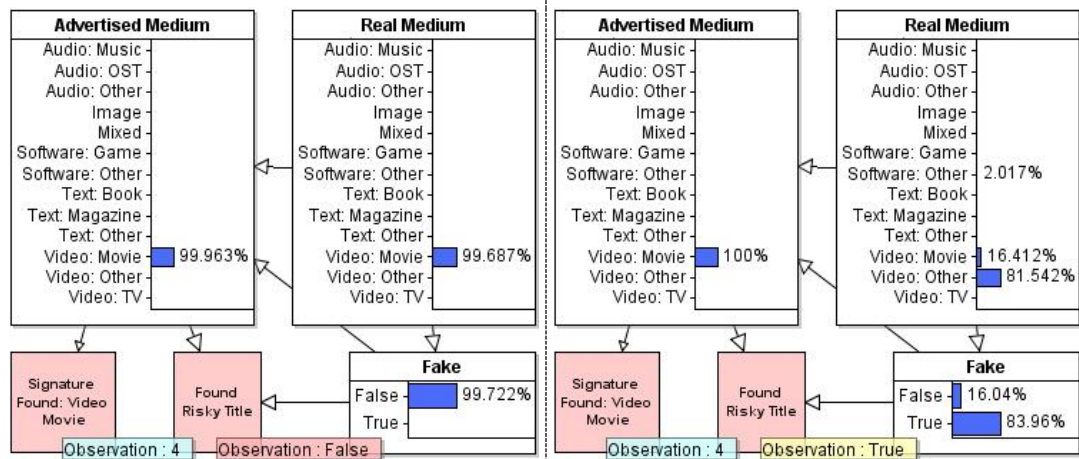

Figure 47: Normal Use of the Risky Title Detection Mechanism for New Torrent Items

Once a 'risky' title is detected in a file name (see Figure 47a), this should lead us to believe that the file is a fake with a high degree of confidence. In this case, it most likely is either a trailer, a short snapshot of the movie running repetitively or featuring the production studio's logo, or simply a broken video. There is also a reasonable probability that the video file would request the viewer to download a 'codec' by following a link to a web page planted with malware. Most items, however, will not be positively matched to the 'risk group', and our belief would be that they are likely to be what they look like, such as in Figure 47b.

Figure 48 shows that the model is able to correctly classify an item when it is not a fake even when there is evidence that it is. In this example the risky title is detected, but other evidence suggests that the item is music, so the posterior probability of a fake is driven down.

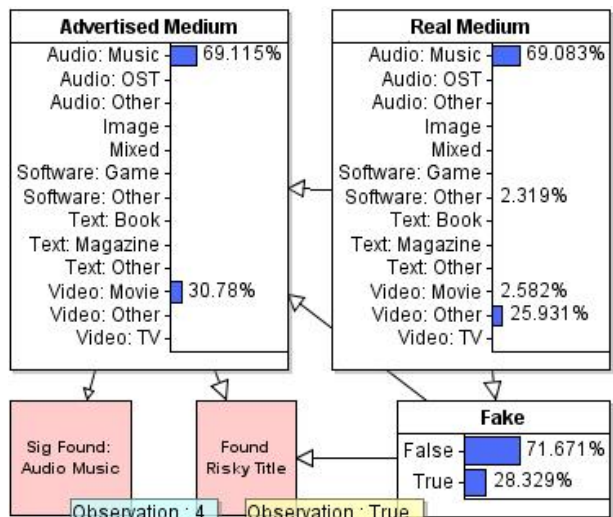

Figure 48: Non-Fake Can Match as Risky Title

When the item is fake, however, the belief is that it most likely will target a movie for reasons explained above.

One of the drawbacks of this approach is that it is heavily dependent on the list of 'risky' titles being up to date, which implies high maintenance costs. Unfortunately, it may be otherwise impossible to establish whether an item is a fake in many cases, relying only on the torrent's name and size.

### 3.13. Extensibility

A model is not set in stone and must be able to adapt to changes in the environment it reflects. While it may be difficult to prepare the model for all kinds of future challenges and types of evidence yet to be observed, there are two most probable scenarios of our model being extended:

#### 1. Changing Medium Signature Associations

A rather simple case is when new data is discovered about relationships between evidence of a particular medium and other medium categories. For example, if a strong link between "Text: Magazine" and "Video: TV" is established, then we re-generate the column for "Video: TV" in the *Text: Magazine Signature Found* according to the strength of the relationship and the procedure outlined in

Algorithm 1. In any other case the solution is ultimately the same and simply requires the distribution in the relevant column to be re-generated with the right parameters.

## 2. Revising Taxonomy

Most of the nodes in the BN are child nodes of *Real Medium* or *Advertised Medium* which means that a change to taxonomy will require most NPTs in the model to be updated. While the existing hierarchy allows all possible items to be classified, alternative variations or granularity levels are possible. New NPTs will have to be derived from the relationship between the old and new hierarchies. Here are a few examples:

a) Change “Audio: Soundtrack” to “Audio: Music: Soundtrack”

In this case we only need to amend “Audio: Music” to “Audio: Music: Other” to specify that it does not include soundtrack, and no other changes are required.

b) Add a category “Video: Other: Trailer”

This change requires “Video: Other” to be updated to “Video: Other except Trailers” and to have its probability reduced to accommodate a new probability appearing for the trailers in *Real Medium*. Similarly, conditional probabilities for “Video: Other: Trailer” in the nodes *Fake*, *Advertised Medium*, *Found Date*, *Found in Database*, *Found in Risk Group* take some value from “Video: Other except Trailers” depending on the relation to medium being specifically a trailer. For example, it is relevant for the node *Fake*, because trailers are one of the mediums of fakes together with “Video: Other except Trailers” and “Software: Other”. The node *Porn* is largely unaffected and trailers must be given very low probability. In *Malware* a zero probability can be assumed for trailers. For medium signature nodes the column is defined depending on the expected relationship to the category. For example, it is reasonable to expect a stronger relationship in “Video: Movie” *Signature Found* and a weaker relationship in other video evidence nodes. For other signature nodes the same column is used as for the “Video: Other except

Trailers". A new signature node is required to model trailer-specific evidence like a keyword 'trailer', for which movies should get a stronger relationship and other video categories a weaker one.

### 3.14. Summary

The primary background highlighted by this chapter comes from Bayesian Network modelling for the purpose of classification, and string alignment to aid title identification. This chapter covered in detail the topics of Bayesian calculus and discussion about modelling and interpreting uncertainty which is inherent to our everyday lives; and approaches to constructing BNs and parameter elicitation.

In this chapter we also covered in detail the structure and logic of our classification model. The primary attributes of a downloadable item the model predicts are: real medium, porn content, risk of fakes and malware. One of the key concepts of the model is the distinction between what an item looks like and what it really is. Most of the evidence we may gather is directly related to the appearance of the item and not necessarily its true nature, hence most of the observation nodes are linked to *Real Medium* via *Advertised Medium*. We capture evidence by looking for media type signatures, title matches, porn keywords, studios and actors.

This chapter also provides reasoning behind conditional prior probabilities in the BN's NPTs and provides insight into how the model evolved over the course of the project. It explains the concept of signature nodes which are able to indicate the medium category most likely to contain the detected evidence. We recognise that some medium categories are more closely related than the others and use these relationships to build the conditional probability distributions for the *signature found nodes'* NPTs.

Lastly, we cover possible ways of extending the model by providing a number of scenarios for future work and improvement.

# Chapter 4

## Capturing Evidence

In this chapter we address *Research objective 1* (from Section 1.2) by providing the means to automatically gather evidence to be used as inputs for the BN model described in Chapter 3. This chapter describes the processing of strings (e.g. file names) in order to extract observations for the Bayesian network model. The chapter defines relevant rules and explains how an expert system was built encoding the original MovieLabs expertise combined with our study of DS2500 and newly posted torrent items.

Separating the configuration of evidence signatures and their category association strengths provides an extension to the model that is flexible and can be updated easier without having to change BN structure or priors.

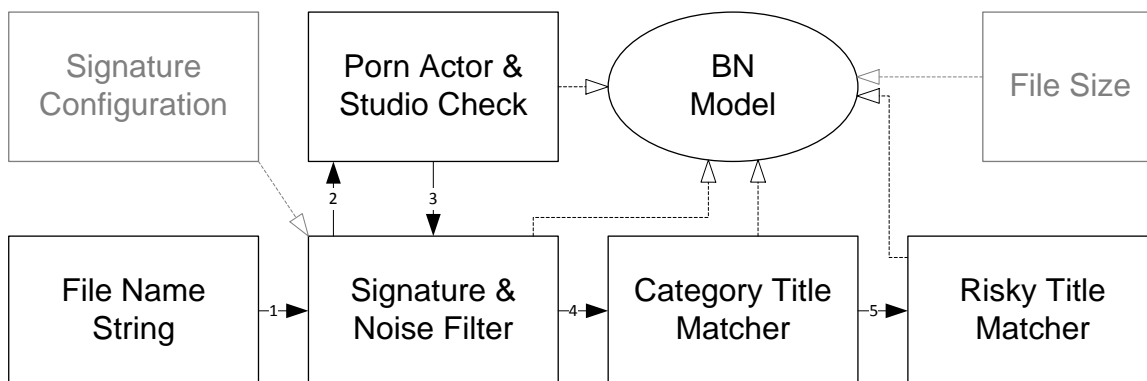

Figure 49: Evidence Entering into the Classifier BN Model

The chapter is therefore primarily concerned with collecting evidence for the BN model from torrent names. Figure 49 describes Toran extracting evidence (solid ended arrows) and entering it into the model (empty ended arrows). Given a torrent name, we first run it through our database of signatures.

Most signatures are associated with a node in the BN and observations are entered into the model based on the evidence extracted from the name string. We also apply a number of regular expressions to the name string in order to clear as much

noise (such as brackets, extra spaces, other separator characters etc.) as possible. The remainder of the name string is considered a candidate title and is then matched to our database of titles. The result of this procedure is used as an observation for the model. Finally, we check whether the name string contains a 'risky' title, which is a process similar to the regular title matching, but is only concerned with a small list of titles, which has to be regularly updated.

The remainder of this chapter is structured as follows: Section 4.1 covers in detail how we define links between evidence and medium categories or other nodes in the network. Section 4.2 explains how we use the names of porn studios and actors and how these records are matched against a file name. Section 4.3 details the procedure and the algorithm of extracting observations and filtering the file names. Section 4.4 is concerned with the title matching procedure, and explains the challenges and practical issues we faced. Section 4.5 outlines the possibility for expanding the list of discoverable signatures or incorporating new data.

## 4.1. Signature Definition

MovieLabs use a set of over 600 items (see Appendix Section H.1) as keywords to match against names. However, these are not exactly keywords as they also include names of porn actresses, popular software packages, movie studios and some other titles. We studied the DS2500 sample in order to expand and refine this set of keywords, and then ultimately decided to transform the concept of keywords into the concept of regular expressions, which we now refer to as signatures. Full configuration of signatures is available in Appendix Section H.2. Using regular expressions rather than exact keywords allows adopting a form of stemming (as specified in Section 2.6.1) and make each signature apply to a number of possible forms within the file name string.



Each signature record has the following attributes:

- Order of application
- Type
- Regular expression
- Associated categories with strength of each such association

A simple example is presented in Table 46. The meaning of this signature is that it either suggests that the file is a movie or TV series or episode with dubbing, or it refers to a genre of electronic music. Category weights suggest that this signature is more relevant to videos rather than music, and are informed by expert judgement and our own study of the DS2500 sample. Type 501 means that this signature must be removed from the file name string if it is surrounded by separators, which is covered in more detail in Section 4.1.1.

Attribute	Value
Order	11
Type	501
Regular Expression	dub(bed)?
Associations	Video: TV (0.25) Video: Movie (0.25) Audio: Music (0.10)

Table 46: Basic Signature Example

Detection of signatures is paired with filtering the torrent name string, which makes the order of application of regular expressions important. For example, considering items such as in Table 47, we want to match and remove **HDTVrip** before **HDTV**, because the former is a larger keyword and removing the latter first could result in a residual **Rip** which could then lead to a wrong interpretation of the evidence. These two keywords have different semantic meanings – the former generally refers to videos ripped from an HD stream and is not limited to TV episodes, while the latter refers to TV episodes much more often than to other types of video.

Category	Torrent Name
Video: TV	House.S07E17.PROPER.HDTV.XviD.2HD
Video: Other	One_Rat_Short (2006).HDTVrip.720p.mp4

Table 47: Example – Torrent Names with HDTV and HDTVrip Signatures

Another example is DVD which more commonly appears in plain form for video processing software packages than for video files themselves. However, there are a number of signatures based on this keyword that strongly relate to various videos, such as HDDVDRip, DVDPAL, DVDScreener, DVD5 etc. Note that these signatures have varying strength of relations to different video sub-categories.

All signatures are loosely separated into 17 ordered groups and are matched case-insensitively except for one special case, which is covered in Section 4.1.3.

- 1) TV patterns to match a wide variety of ‘season X episode Y’ type combinations, including some combinations from other languages; see Section 4.1.3 for further details;
- 2) Date and year;
- 3) A number of porn-associated release groups and domains;
- 4) File extensions;
- 5) Release groups and domains not associated with porn;
- 6) Other domains;
- 7) A particular IP address pattern that is associated with porn (see Section 4.1.3 for details);
- 8) Strong language patterns;
- 9) Weak language patterns and subtitles;
- 10) Various signatures related to medium categories;
- 11) Various signatures related to medium categories that must be applied after (10);
- 12) Porn signatures;

- 13) A special porn signature referring to a popular way of encoding porn movie names (e.g. KTDS-529, see Section 4.1.3 for details);
- 14) Various signatures and release groups related to medium categories that must be applied after (13);
- 15) Numeric sequences that are not dates or years;
- 16) Countries, which appear mostly in names of video files;
- 17) Several patterns to clear up filtering leftovers, primarily non-alphanumeric characters, but also patterns to remove substrings that were not associated with any model observations and are unlikely to be a part of a title (e.g. the highlighted content in Figure 50) and most commonly referred to torrent releasers.

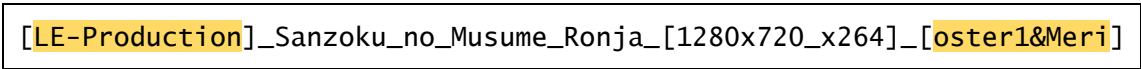

```
[LE-Production]_Sanzoku_no_Musume_Ronja_[1280x720_x264]_[oster1&Meri]
```

Figure 50: Torrent Name Example with Disposable Data

The remainder of this section is structured as follows: Sub-section 4.1.1 covers in more detail the different signature types. Sub-section 4.1.2 explains how we define associations between medium categories and signatures and their strength. Sub-section 4.3 provides an overview and explanation of the procedure of detecting signatures in a torrent name. Sub-section 4.1.3 covers in more detail several non-trivial signatures.

#### 4.1.1. Pattern Types

It was indicated earlier that signatures not only capture observations for the BN, but also clear up the torrent name string such that, ideally, only an item's title and release year are left. Hence all signatures refer to either removable or non-removable content. The general idea is to remove all signatures that reasonably should not be a part of a title. Of course, there is always a possibility that somebody makes a movie called e.g. 'Best of torrent mp3s', but we believe it is a reasonable compromise to model more common items instead.

Apart from removability, signature types refer to common conditions on the signature surroundings within the torrent string. For example, signature type 701 adds optional domain prefix (e.g. `www`) and suffix (e.g. `org`, `net`, `com` etc.) and then removes any part of the name string which matches the resulting regular expression. For instance, using `torrents` as such a signature will match the gold-highlighted substring in all torrents in Table 48. An obvious improvement is to allow the expression to absorb neighbouring sequences of alphanumeric characters (e.g. by adding `[\p{N}\p{L}]*` on both sides of the string ‘torrents’), which expands the matches to blue-highlighted substrings.

Torrent Name Example
talking.slovoed.deluxe.7.1_ <code>[torrents.ru]</code>
Pyar Ka Punchnama (2011) 1CD DVDRip Xvid MSubs( <code>www.masti</code> <code>torrents.com</code> )
[DVD-9-AYN] POONGATRILEUNSWASATHAI- <code>www.tamil</code> <code>torrents.net</code> -arun14184
Windows Loader v1.9.7 [h33t] <code>[rahul</code> <code>torrents]</code>
De1Dengi042010 <code>[Big</code> <code>torrents.org]</code> .pdf

Table 48: A Few Examples Torrent Names Matching the `torrents` Signature

A separator is a sequence of non-alphanumeric characters, except `$` and `@` that matches the pattern `[\^\p{L}\p{N}\$@]`. We decided to use this definition because of the high degree of variability in punctuation used by torrent posters to separate words in the name string.

We group patterns together in order to improve the effect of filtering and reduce processing time. The following properties are taken into consideration when grouping:

- Whether a pattern can be safely removed from the string, or it can be a part of another pattern or used as a word in a title (e.g. ‘movie’ is often used in titles so should not be removed). Such removable pattern can be used as evidence or simply match noise.

- Whether there are any conditions on the context (e.g. surrounding characters) to match a pattern.
- If a pattern is removable, whether any surrounding characters could also be removed. This property simplifies configuration and maintenance of signatures since it is effectively factorisation of common removable context.

We arrived at this configuration after a lot of experimenting with DS2500. The signatures are grouped into following types:

- a) Matches if surrounded by non-alphanumeric characters, and removed. This type is mostly reserved to file extensions such as audio extension `mp3`.
- b) Matches if found as a substring, and removed. It is suitable for patterns which are not expected to be a part of something else or deemed safe to be simply cut out e.g. image or video dimensions `1920[xx×]1080p?`.
- c) Like b) but not removed and is useful for patterns that have a meaning and can also appear as parts of a title, and is mostly used with porn keywords.
- d) Matches if surrounded by separators, and removed. It is suitable for patterns that are complete exact words e.g. `full.?movie`.
- e) Like d) but not removable and is appropriate for separate words that have category associations but may also appear in a title, e.g. `babysitters?`.
- f) Matches if found between open and closed brackets, and removed. It is used for clean-up patterns to remove unnecessary punctuation remaining after filtering, and to remove a small number of specific releaser patterns that are related to common release groups, e.g. `malestom`.
- g) Matches if found between open and closed brackets, and removed together with all content up to the nearest open and closed bracket to the left and right respectively. It is suitable for removing releaser patterns e.g. `mix(ed)?.by`.
- h) Matches if found as a substring, and is removed together with an optional domain prefix (e.g. `www`) and suffix (e.g. `org`, `net` or `com` etc.). It is used to

match potential domain addresses of seeders and release groups, and also to remove all unknown domains from the name string.

- i) Matches if found as a substring, and is removed together with optional surrounding sequences of alpha-numeric characters. It is used to clean up parts of the name string that contain patterns that are unlikely to be a part of a title e.g. `downloader`.

These signature types allow for a flexible configuration of signatures and simplification of the pattern definition within signatures as we can simply specify what prefix and suffix should be attached to a signature pattern.

#### 4.1.2. Associations and Strength

We analysed the DS2500 sample to make sure important relations between categories were not missed. We ran each item from the sample through the signature association and strength detection procedure explained in Algorithm 3 to make our priors partially informed by data.

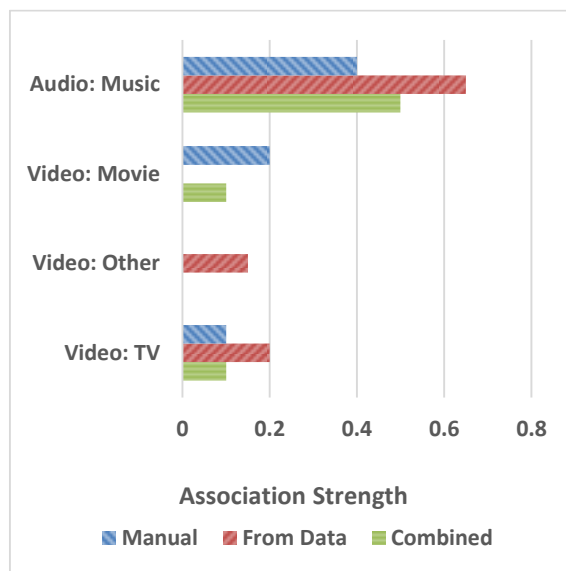

Figure 51: Medium Category Associations of Signature live

Figure 51 shows a frequency distribution of the `live` signature per medium category in DS2500, as well as prior manual definitions and the final combined

values. Note that the observations from data may help refine manually defined values and make the final associations more relevant.

Algorithms 3, 4, 5 and 6 are motivated by theory from Section 2.6.1 and are collectively a procedure for analysing a data sample of pre-classified torrents and extracting signature to category associations and their strengths directly from data. Then a new configuration of signatures is suggested, based on a balanced fusion of existing set up and the attributes learnt from data.

```

// Variables: torrent and signature databases  $D_T$  and  $D_S$ , temporary signature
map  $\widehat{D}_S$ , signature count map  $C_S$ , category count map  $C_C$ 
// Gather frequencies per signature per category
for each  $t \in D_T$  do {
     $t.filtered = t.name$ 
    for each  $s \in D_S$  do {
        if  $t.filtered$  matches  $s.pattern$  {
            if  $s.removable$  {
                 $t.filtered = t.filtered.remove(s.pattern)$ 
            }
             $C_S[s] += 1$ 
             $C_C[t.category] += 1$ 
             $\widehat{D}_S[s, t.category] += 1$ 
        }
    }
}

```

Algorithm 3: Gather Signature Frequencies

Algorithm 3 assumes that all items in  $D_T$  are properly labelled, and is mainly suitable for medium category associations and porn. However, it may also be adapted to provide more insight into associations for special signatures like date, subtitles, language and year.

```

// Variables: category average count  $A_c$ , temporary signature map  $\widehat{D}_s$ 
for each  $c \in C_c$  do {
     $A_c += c.count$ 
}
// Calculate average count per category
 $A_c = A_c / C_c.size$ 
// Weigh each temporary signature association by frequency of appearance
for each  $(s, c) \in \widehat{D}_s$  {
    if  $\widehat{D}_s[s, c] < A_c$  {
        // Signature was rarely seen for category  $c$ , weigh it by  $A_c$ 
         $\widehat{D}_s[s, c] = \widehat{D}_s[s, c] / A_c$ 
    }
    else {
        // Signature was seen for category  $c$  more than average,
        // weigh by category  $c$  count
         $\widehat{D}_s[s, c] = \widehat{D}_s[s, c] / C_c[c]$ 
    }
}
}

```

Algorithm 4: Weigh Category Counts (Continuation of Algorithm 3)

Algorithm 4 is a procedure to weigh the significance of each association within a particular signature. If a category was generally rarely observed in the sample, it should not be taken as reliable. Instead, it is given a lesser weight by dividing it by general category average count. If, however, a category was seen relatively often, we may then conclude that association with a signature may be meaningful.

Algorithm 5 is the next step and describes normalising association values within each signature to add up to the signature max weight  $W_{max} = 3$ , which is a reasonable value for a very strong single association, and may be fairly distributed among several associations of a signature. Essentially normalisation is the same as in Algorithm 2, but the final values are multiplied by  $W_{max}$ . After normalisation weak results below threshold  $\tau_w = 0.1$  are filtered out.



```

// Variables: temporary signature map  $\widehat{D}_S$ , signature max weight  $W_{max}$ ,
// threshold  $\tau_w$ 
for each  $s \in \widehat{D}_S$  {
    // Invoke Algorithm 2
    NORMALISE( $s.associations$ )
    for /* association */  $a \in s$  {
         $a.strength *= W_{max}$ 
        if  $a.strength < \tau_w$  {
             $s.remove(a)$ 
        }
    }
}

```

Algorithm 5: Normalise and Filter Associations (Continuation of Algorithm 4)

Finally, a new set of signature associations is suggested by combining  $D_S$  and  $\widehat{D}_S$  by weighing them appropriately. Each signature is weighted separately by assessing how often the signature was detected in the sample. A rare occurrence in the sample is weighted heavily towards the old configuration while a frequent sighting of a signature in the sample gives it more credibility. However, we decided to limit the maximum weight, which can be applied to an update from the sample, to 0.3 on the basis that an existing set up should be gradually updated with new data rather than be significantly impacted straight away.

As defined in Algorithm 6, the weight for an update is calculated based on individual signature appearance frequency in the sample compared to that of an average signature. Rare signatures are capped at 0.1 weight and more frequent signatures are assigned a weight between 0.1 and 0.3. This weighting policy expresses our belief in reliability or significance of the sample that is used for updating association strengths. If the confidence in the sample is higher than 0.3, it is possible to use the same sample multiple times to update associations, such that each subsequent application of the update procedure would make the final associations closer to those derived from the sample. Alternatively, a different weighting policy could be used.

Algorithm 6 assumes that the signatures that did not appear in the sample at all are not included in the calculation of the average signature appearance count  $A_S$  on the premise that such signatures should simply be unaffected by this configuration update. In fact, the sample may be specifically themed towards a particular set of signatures which would put other signatures at a disadvantage, which should not be allowed.

Once the final strength value for an association was calculated, it is only kept if it is above threshold  $\tau_A = 0.15$ , which is supposed to keep signatures specialised rather than provide a general blanket distribution for all categories.

```

// Variables: signature database  $D_S$ , temporary signature map  $\widehat{D}_S$ ,
// signature count map  $C_S$ , average non-zero signature count  $A_S$ ,
// update weight  $W_U$ , original weight  $W_O$ , threshold for associations  $\tau_A$ ,
// total number of signature occurrences  $|C_S|$ 
for each  $s \in \widehat{D}_S$  {
    if  $C_S[s] < A_S$  {
        // Rarely observed signature, weight up to 0.1
         $W_U = 0.1 * C_S[s] / A_S$ 
    }
    else {
        // Frequently observed signature, weight between 0.1 and 0.3
         $W_U = 0.1 + 0.2 * C_S[s] / |C_S|$ 
    }
     $W_O = 1 - W_U$ 
    for /* association */  $a \in s$  {
         $a.strength = a.strength * W_U + D_S[s, a.category].strength * W_O$ 
        if  $a.strength < \tau_A$  {
             $s.remove(a)$ 
        }
    }
}
return  $\widehat{D}_S$ 

```

Algorithm 6: Updating Signature Associations (Continuation of Algorithm 5)

Inspecting the data in this manner helped us define the final strength figures. However, we could not simply take associations and strengths from the data. To confidently use such an approach alone we would need a much larger sample,

with each medium sub-category appearing a sufficient number of times. Therefore, to a large extent, the strengths and associations of signatures rely on expert judgement, informed by data and general understanding of the field.

We studied final classification results on the DS2500 set iteratively, sensibly tweaking effects of applicable signatures for items that were classified poorly until we were satisfied with the method's performance. We used three separate sample sets as a safeguard from overfitting to original DS2500 data.

### 4.1.3. Special Signatures

Some signatures are very large and elaborate. We do not necessarily aim to optimise the signature detection mechanism for performance, but we do have to keep the database of signatures easy to maintain while it is in development and hence some items may not appear properly structured. This section covers several important signatures which may not be included in the overall list in the appendices due to their size or composition and may be difficult to understand without an explanation unlike most of the signatures.

#### a) Complex TV signature

Most TV series or episodes torrent names' try to identify a particular season or episode within the series, or even a more complex combination of them. Often these may be given in foreign languages or in certain format. Table 49 illustrates several such examples with the signature highlighted in gold.

Torrent Name Example
Witchblade.season2.episode6.avi
The_Infinite_Vacation_03_(of_05)_(2011).cbz
[AniDub]_Ultimate_Girls_TV_[08_of_12]_[ru_jp]_[704x396_XviD_mp3].avi
Zemlya.Lyubvi.(051-075.seri.iz.150).1999.XviD.TVRip
Futurama.(6.sezon.01.seriya.iz.26).2010.XviD.DVDRip.(HDRip).avi
Versiya.(3.sezon.6.seriya.iz.8).2012.XviD.SATRip.avi
[한글]스파르타쿠스 벤젠스 시즌2 7화 저용량
Эпизод 9 - Рефлексы Часть I .mp4

Table 49: A Few Examples Torrent Names Matching the Special TV Signature

The signature is composed of several ‘scenarios’, each of which is in turn composed of a combination of common parts (see Appendix Table I.1). Each part is a simple set of possible options combined as a union.

- Part 1 (P1) generally matches the state of a season such as ‘full’, ‘whole’, ‘all’ etc.;
- Part 2 (P2) provides a mix of expressions for ‘season’ and ‘episode’ in a number of forms and languages;
- Part 3 (P3) matches membership articles such as ‘of’, ‘from’ etc.;
- Part 4 (P4) describes the episode’s number, e.g. numbers of words like ‘one’.

There are several options for these parts to be combined together:

- P4, P2, P4, P2, P3, P4,
- P2, P4, P2, P4,
- P4, P2, P3, P4,
- P2, P4, P3, P4,
- P1, P2, P4,
- P4, P3, P4,
- P1, P2,
- P2, P4

The separator between a pair of parts is assumed to be a sequence of non-alphanumeric characters of length 0 to 3. This helps us ensure that common separators do not get into the way of detection. An example interpretation of “P4, P2, P4, P2, P3, P4” could be ‘3 season 5 episode of 12’.

b) IP address porn

A rare but practically definitive porn signature follows the pattern of an IP address starting with either 3 or 6 and having only two digits in the first group, which can sometimes be followed by a number in brackets. It is defined in Figure 52 and is matched and removed directly from the name string without restrictions.

```
[36]\d{1,2}(\p{Ps}[0-9]\p{Pe})?\.\d{1,3}\.\d{1,3}\.\d{1,3}
```

Figure 52: Porn IP Signature Pattern

c) Special porn signature

We noticed that a portion of porn videos contain a specific pattern of:

- 3 capital letters followed by a possible dash and then 2-4 numbers;
- Or 2-4 capital letters followed by 3 numbers.

However, it also often appears for non-porn items such as music, so we decided to define this signature as: weak porn, strong “Video: Other”, weak “Video: Movie” and medium “Audio: Music”. This is the only case where a match is forced to be case-sensitive.

## 4.2. Porn Studios and Actors

Porn studios and actors are stored as two separate lists (see Appendix C) in pre-processed format as regular expressions. For porn studios spaces in the name are replaced with .? which allows them to be matched if separated by other characters or found in the name string without separators at all. For actor names a similar logic is applied, however we not only check for a Name.?Surname pattern, but

also Surname .?Name. While this provides us with a great opportunity to detect porn, this part of the detection mechanism clearly depends on the quality of studios and actors database and could be further expanded. If matched, both porn studios are removed from the torrent name string, though actors' names are kept since there could be porn movies containing porn actor's name in the title.

### 4.3. Signature Detection and Filtering Algorithm

The detection and filtering procedure closely follows the ordering groups given in Section 4.1 with a few additions, and is formally defined as Algorithm 7. The list below informally summarises the complete filtering procedure. Note that, as shown in Table 48, some signatures may be detected by patterns of other signatures. Therefore, matching order may be important for some patterns, which is especially relevant in case of bigger patterns associated with strong evidence. For example, the TV pattern is quite complex and involves words in multiple languages as well as digits. It is also a very strong piece of evidence and to guarantee its detection, it is matched first. Date and year patterns may easily be absorbed by some of the other signatures and are therefore matched early. Some groups have similar priority or are unlikely to overlap, but are grouped together to simplify configuration maintenance (e.g. groups 3-5, 6-7 and 9-14). The noise group is extremely aggressive in matching and has to be applied last, or it would remove a lot of potentially useful evidence.

- 1) Match and remove TV patterns
- 2) Numerical patterns
  - a) Match and remove full dates
  - b) Match 4-digit 19xx and 20xx years
- 3) Match and/or remove porn studio and actors' names
- 4) Match and remove porn release groups or domains

- 5) Match and remove all file extensions, surrounded by non-alphanumeric characters
- 6) Match and remove known domains or release groups (for example, SKIDROW refers to a community of game crackers and any file containing this keyword is almost certainly a game)
- 7) Remove other domains (e.g. `www.byte.to` is a reference to a torrent tracker which is used to share all kinds of files and is not associated with any particular category)
- 8) Match and remove porn IP pattern
- 9) Match full language keywords, and remove if surrounded by brackets e.g. `[English]`, because otherwise may be a part of a title
- 10) Match and remove short language patterns surrounded by separators
- 11) Match and remove, depending on type, universal keywords or patterns
- 12) Match and remove, depending on type, specialised keywords or patterns
- 13) Match and remove, depending on type, porn keywords or patterns
- 14) Match and remove the special porn pattern
- 15) Match and remove, depending on type, brands or release groups
- 16) Match and remove non-year numeric sequences surrounded by brackets
- 17) Match countries
- 18) Clean up noise
  - a) Trim non alphanumeric characters from start and end until opening or closing bracket respectively
  - b) Remove the single ending word, if preceded by a bracket
  - c) Remove the 'distributor' pattern (e.g. `by Group` or `[-EKZ]` which are the nickname of the person or group who shared the file and are not yet associated with any particular category)
  - d) Remove brackets that do not have alphanumeric values between them

- e) Remove secondary ‘distributor’ pattern (i.e. contents of first and last brackets)
- f) Remove ending ‘distributor’ pattern (i.e. sequence starting with a dash followed by (a space and) numbers or letters, trailing with separators, until the end)
- g) Replace separator sequences by a space

Algorithm 7 is the main procedure and relies on Algorithms 8 and 9. It takes torrent name  $N$  and BN model  $M$  as parameters, and returns filtered torrent name.

```

// Parameters: torrent name  $N$ , BN model  $M$ 
// Variables: signature database  $D_S$ , observations map  $O$ 
for each  $s \in D_S$  do {
    if  $N$  matches  $s.pattern$  {
        if  $s.removable$  {
             $N = N.remove(s.pattern)$ 
        }
        // Invoke Algorithm 8
        RECORD_OBSERVATION( $s, O$ )
    }
    if  $s.order == 3$  {
        // Invoke Algorithm 9
         $N = FILTER_PORN_STUDIO_ACTOR(N, O)$ 
    }
}
// Transfer gathered evidence to model
for each  $o \in O$  do {
     $M_{o.node} = o.value$ 
}
Return  $N$ 

```

Algorithm 7: Detect Signatures and Filter Torrent Name

Algorithm 8 assumes that an association from a signature to a medium category corresponds uniquely to a node in the BN, and takes a signature  $s$  and the map of observations  $O$  as parameters.



```

// Parameters: signature  $s$ , map of observations  $O$ 
for each /* association */  $a \in s_A$  do {
    if  $a.node.type$  is Boolean {
        // Boolean evidence found, set to true
         $O_{node.name} = true$ 
    }
    else {
        // Node is numeric, accumulate evidence
         $O_{node.name} += a.strength$ 
    }
}

```

Algorithm 8: Record Signature Observations

Algorithm 9 takes the torrent name  $N$ , a signature  $s$  and the map of observations  $O$  as parameters, and returns filtered torrent name.

```

// Parameters: torrent name  $N$ , map of observations  $O$ 
// Variables: porn actor and studio databases  $D_{PA}$  and  $D_{PS}$ ,
// observations map  $O$ 
for each /* studio record */  $r \in D_{PS}$  do {
    if  $N$  matches  $r.pattern$  {
        // Set observation and filter name
         $O_{r.node_name} = true$ 
         $N = N.remove(r.pattern)$ 
    }
}
for each /* actor record */  $r \in D_{PA}$  do {
    if  $N$  matches  $r.pattern1$  or  $N$  matches  $r.pattern2$  {
        // Set observation
         $O_{r.node_name} = true$ 
    }
}
return  $N$ 

```

Algorithm 9: Detect and Filter Porn Studios and Actors

To illustrate the procedure given above let us consider two torrent record names with signature matches highlighted in gold in Table 50.

#	Original Torrent Name
1	Ghost.Rider : Spirit.of.Vengeance.2012.2D.BluRay.1080p.AVC.DTS-HD.MA5.1-CHDBits
2	Phineas.i.Ferb.(1.sezon.25-26.serii.iz.32).2008.XviD.SATRip.-Puzkarapuz

Table 50: Example Torrents for Signature Detection and Filtering Illustration

Table 51 provides an overview of all meaningful signatures detected in the torrent names from Table 50. Refer to the short sub-category names in Table 4. Note that clear-up patterns are omitted.

Torrent #1			Torrent #2		
Signature Match	Associated Node	Strength	Signature Match	Associated Node	Strength
AVC	Video: Movie	0.75	1.sezon.25-26.serii.iz.32	Video: TV	2.95
	Video: Other	0.3		2008	Year
	Video: TV	0.45	XviD	Video: Movie	0.8
MA5.1	Software: Other	0.2		Video: Other	0.45
	Video: Movie	0.45		Video: TV	0.55
	Software: Game	0.2	SATRip	Video: Movie	0.4
	Video: TV	0.4		Video: Other	0.4
1080p	Video: Movie	0.85		Video: TV	0.95
	Video: Other	0.6			
	Video: TV	0.6			
2D	Video: Movie	0.7			
	Video: Other	0.7			
	Video: TV	0.7			
BluRay	Video: Movie	1			
	Video: Other	0.3			
	Video: TV	0.3			
DTS	Audio: Other	0.2			
	Video: Movie	0.5			
	Audio: OST	0.2			
	Audio: Music	0.4			
HD	Image	0.15			
	Video: Movie	0.45			
	Video: Other	0.35			
	Software: Game	0.15			
	Video: TV	0.35			
2012	Year	1			

Table 51: Signatures Detected in Torrents from Table 50

As per Algorithm 7 above, for each torrent record we calculate cumulative strength for each numeric evidence node, illustrated by Table 52. Note that the category with the highest cumulative strength actually matches the expected category of the torrent, i.e. movie for Torrent #1 and TV for Torrent #2. Entering such observations into the BN model naturally reinforces the correct prediction.

Torrent #1		Torrent #2	
Category	Cumulative Strength	Category	Cumulative Strength
Audio: Music	0.40	Video: Movie	1.20
Audio: OST	0.20	Video: Other	0.85
Audio: Other	0.20	Video: TV	4.45
Image	0.15		
Software: Game	0.35		
Software: Other	0.20		
Video: Movie	4.70		
Video: Other	2.25		
Video: TV	2.80		

Table 52: Cumulative Signature Strength from Table 51

Finally, after the filtering was performed, the resulting strings contain only the movie and TV series titles, including release years as illustrated by Table 53. More examples of original and filtered torrent names can be found in Appendix J.

#	Torrent Name After Filtering
1	Ghost Rider : Spirit of Vengeance 2012
2	Phineas i Ferb 2008

Table 53: Torrent Names from Table 50 after Filtering

The next step is to perform title matching, explained in the next section.

#### 4.4. Title Matching

The central idea of title matching is the possibility to improve medium classification if the title of the downloadable file content was correctly identified, by making the assumption that file content is of the same type as the identified title. For example, when we detect a movie title in the torrent name, this increases our belief that the file is a “Video: Movie”, unless there is sufficient evidence to believe otherwise (e.g. signatures of audio, soundtrack and small file size). An additional benefit is the ability to sensibly predict the medium even if no traces of actual file type are found in the torrent name, and only the title is present, e.g. as in torrent from Figure 53.

The Hobbit: The Battle of the Five Armies (2014)

Figure 53: Example of Torrent without File Type Evidence

In the file names the most common titles to be found are movies, TV series, games and music. As explained in Section 2.4, we use a list of movie, TV series and game titles imported from IMDb. It is absolutely crucial that the database of titles used for identification is well built and maintained, because file names inherently contain text that can lead to false matches against a title, which is especially true for very long titles or file names.

The rest of this section is structured as follows: Section 4.4.1 explains in detail how torrent names and titles are aligned. Section 4.4.2 covers the n-gram pre-filtering procedure that we use to greatly reduce processing time. Section 4.4.3 describes the complete process of matching a title and how all parts and procedures are linked together.

#### 4.4.1. Title Alignment

We use string alignment to match titles to torrent names because this provides us with a number of tweaks i.e. scoring rules, which we can use for optimisation. It also provides us with an opportunity to capture imperfectly matching pairs of file name and title strings as though they were identical. We base our algorithm on the SW algorithm and other theory described in Section 2.6. In essence, this algorithm puts two strings next to each other and tries to align them by inserting gaps such that the best alignment score is achieved. The primary differences that we introduce are:

- a) Matching is case insensitive, and implemented by turning both compared strings to upper case.
- b) Matched sub-sequences are scored proportionally to their length, such that the longer the unbroken matched sub-sequence, the higher the score; and that several matched sub-sequences will score lower than a single matched

sub-sequence of the same length. See example in Table 54 where the first title has only 1 matching sub-sequence of length 12 highlighted in yellow and the second title has two matching sub-sequences of 4 and 8 length highlighted yellow and green respectively.

<b>Filtered Torrent Name</b>	Bad Apple 2004
<b>Title 1</b>	Bad Apple 2012
<b>Score 1</b>	367
<b>Title 2</b>	Bad Pineapple 2012
<b>Score 2</b>	146

Table 54: Matching Titles with a Gap and without

- c) Gapping policy specifies a more expensive gap opener, but allows up to 2 gaps at a lower cost. A gap opener in this case is the beginning of a gap longer than 2 characters. Extending a gap further than that also has a cost. Essentially, this makes a number of smaller gaps more attractive than one single gap of the same total length, yet the intent is to account for possible variation in separators (which is partially addressed by prior pattern filtering).
- d) We build on the idea of a substitution matrix to allow numbers to be treated as letters, to handle cases of intentional obfuscation like in Figure 54, where numbers from a torrent are matched to letters in a title, and are indicated by a “+” underneath.

5	0	U	7	H	P	4	R	K	B	4	5	S	T	O	M	0	U	7	H
S	O	U	T	H	P	A	R	K	B	A	S	S	T	O	M	O	U	T	H
+	+		+						++		+	+	+						

Figure 54: Obfuscated Torrent Name Alignment

Otherwise a very taxing score is given to matching differing characters to avoid this completely. Note that such substitutions are allowed one-way only. See Table 55 for complete substitution table.

<b>Character in Torrent Name</b>	0	1	3	4	5	6	7	9
<b>Allowed Substitutions</b>	0	L I	E	A	S	G	H T	G

Table 55: Title Alignment Substitution Table

According to Equation 30, for each possible character alignment, we calculate a score for a match which, in this case, means aligning two characters together, or for inserting a gap. Table 56 summarises the title alignment scoring policy. Adjusting these variables makes it possible to tune the alignment algorithm to other components of our method. For example, the current set up is very strict because we are aware of a rather poor state of the title database, and hence we limit the matches only to confident cases as much as possible.

<b>Variable</b>	<b>Value</b>
Match score	6
Substitution match score	5
Mismatch score	-30
Gap score	-3
Gap expensive score	-20
Expensive gap	3

Table 56: Title Alignment Configuration

The motivation for a large negative mismatch score is to discourage the algorithm matching different digits or characters beyond those allowed in the substitution matrix. The gapping policy is configured in a way that it is more affordable to insert a gap than to mismatch symbols, yet a long gap is more expensive than a symbol mismatch. A low penalty for mismatching would cause the algorithm to align wrong words, while a low penalty for gaps could lead to a situation where the majority of file name or title would be matched to gaps instead of symbols.

The essential idea is that we want to allow some noise in the matched string, but want to keep the algorithm strict enough and be able to see a significant difference

between a clean match and a noisy match. We experimented with the values in Table 56 by calibrating them on the validation set DS480.

Algorithm 10 defines the procedure for calculating a score for matching a pair of characters and takes characters  $C_1$  and  $C_2$ , and the number of consecutive matches  $c$  prior to this comparison, as parameters and returns a score. Note that a pattern of a single symbol match followed by a single gap repetitively, is discouraged by starting to award a positive score only from the second consecutively matched character.

```
// Parameters: characters  $C_1$  and  $C_2$ ,  
// prior consecutive matches  $c$   
if  $C_1 == C_2$  {  
    return  $score\_match \cdot c$   
}  
  
if  $C_1$  substitutes  $C_2$  {  
    return  $score\_substitution\_match \cdot c$   
}  
return  $score\_mismatch$ 
```

Algorithm 10: Score Match

Likewise, Algorithm 11 defines the procedure for calculating a gap score by taking the prior number of consecutive gaps  $g$ .

```
// Parameter: prior consecutive gaps  $g$   
if  $g == expensive\_gap$  {  
    return  $score\_gap\_expensive$   
}  
return  $score\_gap$ 
```

Algorithm 11: Score Gap

Actual alignment score  $S_{actual}^A$  is calculated according to SW algorithm and our scoring policy given above. We calculate the maximum alignment score  $S_{max}^A$ ,

which would be achieved if the filtered torrent was the same as the title; and normalised alignment score  $S_{norm}^A$  according to Equation 39.

$$S_{max}^A = \sum_{l=0}^{L-1} (l \times score\_match)$$

$$S_{norm}^A = \frac{S_{actual}^A}{S_{max}^A}$$
(39)

Where  $L$  is the length of the shortest string of the two aligned. Table 57 illustrates actual and normalised alignment scores for the example from Table 54 above.

	Title 1	Title 2
$S_{max}^A$	546	546
$S_{actual}^A$	367	146
$S_{norm}^A$	0.672	0.267

Table 57: Actual and Normalised Alignment Scores for Table 54

For each torrent we find the best match in each of the categories contained in the title database, namely movies, TV series and games. Section 4.4.3 provides further details for title match selection.

#### 4.4.2. n-gram Pre-filtering

String alignment is often a computationally expensive process (Li & Homer 2010), and it does not really need to be performed for each of the 3.2 million titles we hold on record. Doing so takes 66 seconds on average to filter and identify a torrent record. We draw on the idea of improving retrieval performance (for example, similar to the BLAST algorithm from Section 2.6) by using n-grams to first establish the titles that are even worth attempting to align to.

Before any title alignment is performed, we first determine suitable titles for the filtered torrent name by calculating the proportion of matching 3-grams between the filtered name and the title. For this operation both strings are stripped of any



non-alphanumeric characters. Consider an example in Table 58 which illustrates n-gram generation.

<b>Filtered Name</b>	THE MISFITS
<b>Name 3-grams</b>	THE HEM EMI MIS ISF SFI FIT ITS
<b>Title 1 String</b>	THE MISFIT
<b>Title 1 3-grams</b>	THE HEM EMI MIS ISF SFI FIT
<b>Title 2 String</b>	THE FLUXUS MISFITS
<b>Title 2 3-grams</b>	THE HEF EFL FLU LUX UXU XUS USM SMI MIS ISF SFI FIT ITS

Table 58: Generating 3-grams

We calculate the maximum n-gram score  $S_{max}^G$  according to Equation 40.

$$S_{max}^G = L + 1 - N \quad (40)$$

Where  $L$  is the length of the shortest compared string, and  $N$  is the length of n-grams, which we set to 3. We then calculate the total number of overlapping 3-grams  $S_{actual}^G$  according to Algorithm 12, which takes as parameters: the shorter string (i.e. needle)  $E$ , list of 3-grams of the needle  $G_E$  and the longer string (i.e. haystack)  $H$ . The normalised n-gram score  $S_{norm}^G$  is calculated according to Equation 41.

$$S_{norm}^G = \min\left(1, \frac{S_{actual}^G}{S_{max}^G}\right) \quad (41)$$

Table 59 illustrates n-gram scores for the example in Table 58.

	<b>Title 1</b>	<b>Title 2</b>
$S_{max}^G$	7	8
$S_{actual}^G$	7	6
$S_{norm}^G$	1	0.75

Table 59: n-gram Scores for the Example in Table 58

Because the maximum score is based on the shortest of the two strings, the second title will be considered similar enough for further analysis on the premise that extra content from the title could have been omitted in the torrent name.

```
// Parameters: needle  $E$ , 3-grams  $G_E$ , haystack  $H$ 
// Variables: n-gram score  $S_{actual}^G$ , max n-gram score  $S_{max}^G$ ,
// n-gram length  $N$ 
if  $E.length < N$  and  $H$  contains  $E$  {
    return 1
}
if  $E == N$  {
    return  $S_{max}^G$ 
}
 $S_{actual}^G = 0$ 
for  $g \in G_E$  do {
    if  $H$  contains  $g$  {
         $S_{actual}^G = S_{actual}^G + 1$ 
    }
}
return  $S_{actual}^G$ 
```

Algorithm 12: Calculate Overlapping 3-grams

The normalised n-gram score  $S_{norm}^G$  is calculated according to Algorithm 13. It takes torrent  $t$  and title  $i$  as parameters and returns a score  $S_{norm}^G$ .

```

// Parameters: torrent  $t$ , title  $i$ 
// Variables: n-gram length  $N$ , needle  $E$ , set of n-grams  $G_E$ , haystack  $H$ 
 $L = \text{shortest}(t.\text{filtered}, i.\text{stripped})$ 
 $S_{max}^G = L + 1 - N$ 
if  $t.\text{filtered}.\text{length} < i.\text{stripped}.\text{length}$  {
     $E = t.\text{filtered}$ 
    // Generate ngrams like in Table 58
     $G_E = \text{ngrams}(t.\text{filtered}, 3)$ 
     $H = i.\text{stripped}$ 
}
else {
     $E = i.\text{stripped}$ 
    // Generate ngrams like in Table 58
     $G_E = \text{ngrams}(i.\text{stripped}, 3)$ 
     $H = t.\text{filtered}$ 
}
// Invoke Algorithm 12
 $S_{actual}^G = \text{OVERLAPS}(E, G_E, H)$ 
 $S_{norm}^G = S_{actual}^G / S_{max}^G$ 
return  $S_{norm}^G$ 

```

Algorithm 13: Calculate  $S_{norm}^G$

Note that for Algorithm 13 we strip both strings of any spaces to discount for cases where a torrent name has deliberately no separators between words. Title alignment procedure handles the same cases with scoring rules.

We use a threshold  $\tau_G = 0.5$  to filter out an absolute majority of titles before any alignment is attempted. For the torrent with filtered file name ‘The Misfits’ this procedure quickly eliminates 99.95% titles from the database. This allows us to bring the average processing time to 4 seconds per torrent, down from 66 seconds, which is more than 16 times faster and makes running experiments much easier. These algorithms are essentially of polynomial time complexity (Pocklington 1911; Cobham 1964).

### 4.4.3. Procedure

This section provides further insight into the combined procedure of performing title identification. Algorithm 14 defines a high level procedure of matching an item  $t$  to a database and assumes that all items and database records are represented by strings (e.g. torrent name and a title from database) and may share a secondary property, which follows a particular pattern and positively affects the final match score if shared. Records in the database are assumed to be grouped by category. A record may also be marked as 'alternative', which would reduce any score that it can produce. A 'match' here is an object created for particular item-record pair and describes their matching score; and whether they share the secondary property, referred to as 'shared property'. If two matches have the same score, the one with the shared property is prioritised. Maximum of 1 record can be returned per category (e.g. movie, TV or game). For a match to be considered, it must also have a score above threshold  $\tau_I$ . We tested  $\tau_I$  in the range from 0.75 to 1 and the best results were attained with  $\tau_I = 0.95$ .

```

// Parameter: item  $t$ 
// Variables: database  $D_t$ , set of previously approved matches  $M$ , score threshold  $\tau_t$ 
// First filter out known patterns according to Algorithm 7
 $t.filtered = FILTER(t.original\_string)$ 
for each  $i$  in  $D_t$  {
    // Match object  $m$  created for item  $t$  and record  $i$  according to Algorithm 16
     $m = MATCH(t, i)$ 
    if  $M$  is empty {
         $M.add(m)$ 
        continue
    }
    if  $m.score < \tau_t$  or  $m.score < M[0].score$ {
        // Discard new match if below threshold or worse than previous results
        continue
    }
    if  $m.score > M[0].score$  {
        // If new match has better score, overwrite previous results
        clear  $M$ 
         $M.add(m)$ 
        continue
    }
    // New match is same-score as previous results
    for each  $\hat{m}$  in  $M$  {
        if  $m.category == \hat{m}.category$  {
            // Replace old match of same score and same category,
            // if new match has a shared property
            if  $m.shared\_property$  and not  $\hat{m}.shared\_property$  {
                 $M.remove(\hat{m})$ 
                 $M.add(m)$ 
                // Continue to next item
                continue 2
            }
        }
    }
    //  $M$  does not contain a match object in the same category as new match, add it
     $M.add(m)$ 
}

```

Algorithm 14: Find Best Record Matches for an Item (Part 1)

Algorithm 15 is the part 2 of Algorithm 14 and performs the final round of filtering of the results. At this point set  $M$  may contain either no matches at all, or up to 3 matches of different categories. If any of these matches have a shared property (i.e. year match), then other matches must be removed.

```

// Variable: set of approved matches  $M$ , temporary set  $M_Y$ 
for each  $\hat{m}$  in  $M$  {
    // Copy matches with a shared property to  $M_Y$ 
    if  $\hat{m}.shared\_property$  {
         $M_Y.add(\hat{m})$ 
    }
}
if  $M_Y$  not empty {
    return  $M_Y$ 
}
return  $M$ 

```

Algorithm 15: Find Best Record Matches for an Item (Part 2)

The procedure for actually matching an item to a database record may be separated into 3 major parts:

- 1) Set up and handling trivial cases (see Algorithm 16)
- 2) Choosing n-gram score or alignment score
- 3) Application of penalties and bonuses

```

// Parameter: item  $t$ , record  $i$ 
// Variables: this match  $m$ 
 $m.shared\_property = ( t.filtered \text{ contains } i.secondary\_property )$ 
// Account for short records by concatenating the secondary property
if  $i.stripped.length < 3$  {
     $i.stripped.append(i.secondary\_property)$ 
}
else if  $m.shared\_property$  {
     $t.filtered.remove(i.secondary\_property)$ 
}
if  $t.filtered == i.stripped$  {
     $m.score = 1$ 
    return  $m$ 
}

```

Algorithm 16: Match Item and Record (Part 1)

In application to torrent names and a title database, *i.secondary\_property* refers to title's release year.

The procedure in Algorithm 17 is aimed at establishing the raw match score either via n-gram assessment only, or via string alignment.

```

// Parameter: item  $t$ , record  $i$ 
// Variables: this match  $m$ , score threshold  $H_i$ , score  $S$ , maximum score  $S_{max}$ 
// Invoke Algorithm 13
 $S_{norm}^G = \text{NGRAM\_SCORE}(t, i)$ 
if  $S_{norm}^G < H_i$  {
    //  $S_{norm}^G$  below threshold, no need to do string alignment
     $S = S_{norm}^G$ 
     $S_{max} = S_{max}^G$ 
}
else {
    // Calculate according to Equation 39
     $S = S_{norm}^A$ 
     $S_{max} = S_{max}^A$ 
}
if  $S == 0$  {
     $m.score = S$ 
    return  $m$ 
}

```

Algorithm 17: Match Item and Record (Part 2)

Note that before string alignment is performed, we replace Roman numbers in both strings with Arabic numbers to tackle cases when e.g. ‘Part III’ has to be aligned to ‘Part 3’ with exactly the same score.

Algorithm 18 applies relevant bonuses and penalties to the score. For example, movies and games have a particular release year which normally accompanies the title. This is not the case for TV series because they may span years and initial release year is rarely mentioned. Therefore, in case the matched title is a game or a movie there is a bonus for a year match, or a penalty for a year missing from the torrent name, or a penalty for a mismatch between a year in the title and a year in the torrent name. Another interesting case is when the torrent is matched to a title which is an alternative (i.e. ‘aka’) title. In this case a slight penalty is applied to differentiate such a match from a match to a full independent form of a title. These

bonuses and penalties are applied as multipliers to the match score, which is then divided by the previously calculated maximum score and is capped at 1.

```

// Parameter: item  $t$ , record  $i$ 
// Variables: this match  $m$ , shared property bonus  $B_Y$ ,
// array of record categories  $C_B$  eligible for receiving  $B_Y$ ,
// penalties for missing secondary property  $P_M$  and secondary property mismatch  $P_X$ ,
// penalty for alternative records  $P_K$ ,
// regular expression for detecting secondary properties  $R_Y$ 
if  $i.alternative$  {
     $S *= P_K$ 
}
if  $i.category$  in  $C_B$  {
    if  $m.shared\_property$  {
         $S *= B_Y$ 
    }
    else if  $t.original\_string$  matches  $R_Y$  {
        // Secondary property mismatch
         $S *= P_X$ 
    }
    else {
        // Secondary property missing
         $S *= P_M$ 
    }
}
 $m.score = \min(S, 1)$ 
return  $m$ 

```

Algorithm 18: Match Item and Record (Part 3)

Current bonus and penalty multipliers can be found in Table 60.

Variable	Value
$B_Y$	1.15
$P_M$	0.95
$P_X$	0.9
$P_K$	0.95

Table 60: Bonuses and Penalties for Title Matching

As explained in Section 3.11, title identification is used as evidence for the BN node *Found in DB*. In case only a single match is remaining at the end of identification process, the observation is set as hard evidence for the appropriate category. If



multiple matches were returned, then each category of returned matches will receive soft evidence according to the value of their relevant score. So, for example, if a single match was returned for a movie title with score 0.99, the node *Found in DB* is set to “*Movie*” = *true*; and if on the other hand there was also a match for a game with score 0.99 then virtual evidence entered into the *Found in DB* node resembles a vector as in Table 61.

		<b>Virtual State Evidence</b>
<b><i>Found in DB</i></b>	None	0.0
	Game	0.5
	Movie Not Porn	0.5
	Movie Porn	0.0
	TV	0.0

Table 61: Virtual Evidence for *Found in DB* Example (normalised)

The implication of using soft evidence here is that it will bear less weight when the model calculates than hard evidence.

The same procedure applies to detecting ‘risky’ titles, albeit simpler because only non-porn movies are included on that list.

## 4.5. Extensibility

There are three areas where there is potential for extending and improving the evidence capturing procedure:

### 1. Updating Signature Category Association Strengths

One of the crucial aspects of any working system is the ability to adapt to new conditions. A basic way of improving our approach is by having a few experts classify more downloads to reinforce signature associations to categories, and the strength of these associations.

If the new sample adheres to a different class hierarchy and the sample's significance justifies adopting that taxonomy, then the process described in Section 3.13 2) could be followed. In case the taxonomy is compatible with the one in Table 4, we can use the procedure in Algorithms 3, 4, 5 and 6 to fuse the weights and associations from a data sample with the existing signature configuration.

### 2. Adding New Signatures

New signatures can be added to our configuration to incorporate new knowledge. Once a signature is defined together with all its associations, we can use the same procedure as in Section 4.5 1) to see if there is any useful information in the data to support this signature set up.

### 3. Amending the Database of Titles

The database of titles is likely to be the first part of the method configuration to be updated. The current title database set up has several problems explained in the Future Work Section 7.3. It is, however, a straightforward process to update or completely replace the title database as long as items conform to the general format. Adding, removing or amending a title requires no additional changes and any new items classified after the update will take this new information into account.

## 4.6. Summary

This chapter covers in detail all automatic processes involved in assessing items and in performing actual classification and identification. The process may be summarised as initial detection of medium signatures and file name filtering, then a set of roughly similar titles is quickly identified using n-gram comparison, followed by a much more thorough process of title alignment to get a precise match score.

Lastly, we cover possible ways of extending Toran or updating its configuration by providing a number of scenarios for future work and improvement.

# Chapter 5

## Formal Framework for System Evaluation

This chapter addresses *Research objective 3* (from Section 1.2) by introducing a novel and robust framework to reconcile varying class taxonomies employed by different systems, and probabilistic predictions and non-probabilistic hard verdicts generated by automatic systems and human experts. We propose an extension to well-established error metrics that makes them compatible with a multi-label hierarchical class taxonomy. We show how the framework is used to pre-format and then compare the results achieved by our prototype *Toran* to the results of the benchmark MovieLabs system (*MVL*) and human expert panel (*HP*).

It is crucial to be able to estimate accuracy and effectiveness of an approach once it is formalised and tested. Evaluation of classification algorithms is an area of research of its own (see Section 2.6 for more background), but most accuracy metrics revolve around the concept of real state (i.e. classification) of an item compared to its estimated state (i.e. the outcome of the classifier). We believe that in the absence of a sufficiently large sample of verified items, an assessment of the real item state can be drawn from a human expert, or a majority vote of multiple human experts, which is more desirable. This approximation of the true state can then be compared to the results of the algorithm that is being evaluated.

This chapter is structured as follows: Section 5.1 describes a framework consolidating different class taxonomies and output of various classifying agents. Section 5.2 is concerned with mapping non-probabilistic verdicts of experts and *MVL* to a probabilistic vector and translations between super-category and sub-category prediction vectors. Section 5.3 defines several examples of human panel classifying an item and resulting probability vectors. Section 5.4 identifies requirements that a scoring metric must satisfy in order to be suitable for

comparing results of probabilistic and non-probabilistic agents. Section 5.5 defines the tiered scoring rule which we use for evaluation. Section 5.6 highlights the importance of a random prediction definition.

## 5.1. Compatibility of Agent Output

In this thesis we are concerned with validating the results of our classification method. We gathered several samples of data and built several sets of predictions made by different agents – human experts, MVL and Toran. Output provided by these agents is very different in format. While humans and MVL select a single sub-category or super-category and may return an ‘Unknown’ result, Toran always returns a probabilistic distribution across all sub-categories. Yet we need to compare results provided by these agents in order to evaluate the quality of our predictions.

Using an appropriate evaluation metric or a scoring rule is absolutely crucial, because ultimately, it is this metric that defines whether a classification approach is valid and accurate. An unsuitable metric can lead to completely wrong conclusions. In essence, the work presented in this thesis would be incomplete without proper means of assessing quality of predictions made by Toran by comparing them to predictions made by other agents.

In this section we list a number of challenges arising from classification results comparison and evaluation in similar settings involving agents that provide output in different formats, and present a framework for tackling these challenges. We can summarise the issues in the following list:

### 1) *Mapping*

Human agents as well as MVL can return a classification which is a sub-category (i.e. full classification), a super-category (i.e. partial classification) or “Unknown” while the true state of an item from a set of verified items DS120

is the item's full classification. Toran always returns a vector of probabilities for each sub-category, with all values adding up to 1. This brings forward the problem of *mapping* full, partial and "Unknown" predictions to a probabilistic vector of either super-categories or sub-categories.

### 2) *Related states*

Our classification categories are grouped into a multi-level hierarchy, which makes most classical accuracy metrics not fully appropriate to evaluate classification performance, as explained in Section 2.6.5. For example, an item that belongs to "Video: Movie" must score better being classified as "Video: TV" than being classified as "Audio: Music", because sub-categories of a single super-category are obviously closer to each other than to members of other super-categories. We may address this problem by developing an appropriate scoring rule that extends the well-established metrics and allows handling the issue of multi-level classification hierarchy.

### 3) *Estimated or unknown true state*

The true state of an item is only known for a very limited subset of records where the real classification and identity are verified (i.e. DS120 sample). We developed knowledge and validation sets DS2500 and DS480 respectively by having human experts suggest an estimate of the true state. Three experts may provide varying estimates, which are sometimes completely different. We must be cautious when comparing prediction results between verified data and unverified non-unanimous expert estimates. While the former allows application of a range of existing accuracy metrics, the latter requires us to define the exact procedure to be followed, before any metric can be applied.

An additional issue is that humans themselves may incorrectly classify a proportion of records, which means a truly correct prediction will score badly

against a wrong expert estimate, and this has to be taken into account when interpreting results.

## 5.2. Verdict Mapping and Probability Vector Translation

The most important part of the evaluation process is to compare how different agents classify items with known actual state. We decided to format hard human panel votes and MovieLabs decisions as probability distributions, which would be compatible with results returned by Toran or any other probabilistic system. In our taxonomy there are 6 super-categories and 13 total sub-categories (see Section 2.3). It is important to be able to convert a vector of full category predictions to a vector of partial category predictions and vice versa. This section explains the relevant processes.

### *a) Mapping a single category verdict to a probability vector*

Essentially, every hard verdict given by a human expert or MVL can be represented as a vector of probabilities  $S^P$  with the single selected label having a probability of 1 and all other labels having a probability of 0.

### *b) Human and MVL prior distributions*

In DS2500 MVL classified 1033 items with only a super-category and 244 as “Unknown”. Between the three human classifiers these figures were 563 and 572 respectively. In order to translate such votes into a sub-category distribution we use a concept of prior distribution. We produced the distributions in Table 62 based on the number of full category votes given by MVL or humans in DS2500. The same logic was applied to prior distributions for porn in Table 63.

Category	DS2500 Counts		Derived Prior Distributions			
	Humans	MVL	"Unknown"		Partial	
			Human	MVL	Human	MVL
Audio: Music	971	35	0.15	0.03	0.94	1.00
Audio: OST	29	0	0.00	0.00	0.00	0.00
Audio: Other	59	0	0.01	0.00	0.06	0.00
Image	187	55	0.03	0.04	1.00	1.00
Mixed	0	0	0.00	0.00	1.00	1.00
Software: Game	271	51	0.04	0.04	0.31	0.57
Software: Other	604	42	0.09	0.03	0.69	0.43
Text: Book	279	17	0.04	0.01	0.80	1.00
Text: Magazine	69	0	0.01	0.00	0.20	0.00
Text: Other	24	0	0.00	0.00	0.00	0.00
Video: Movie	1,732	564	0.27	0.46	0.45	0.55
Video: Other	966	129	0.15	0.11	0.25	0.13
Video: TV	1,174	330	0.18	0.27	0.30	0.32
Partial	563	1,033				
Unknown	572	244				

Table 62: Medium Prior Distributions for Humans and MVL

During the accuracy evaluation process, when we consider an ‘unknown’ or partial verdict given by humans or MVL, we use these distributions. In the former case the distribution can be used as a prediction directly, while in the latter the distribution is restricted to the single selected super-category and individual sub-category weights are scaled to sum up to 1.

Porn	Agent Counts		Derived Priors	
	Humans	MVL	Humans	MVL
False	5,548	1,944	0.86	0.94
True	874	126	0.14	0.06
Unknown	1,078	430		

Table 63: Porn Prior Distributions for Humans and MVL

For example, if MVL classifies an item as “Video”, the relevant prediction probability vector has all sub-categories set to 0, except for video sub-categories, which are set according to Table 62 partial distribution for video.

In case we need to calculate prediction accuracy for humans against an actual item’s classification, we convert individual human votes using the same logic, then



sum up their relevant distributions into one and normalise it such that all values add up to 1.

c) *Translating a full category to partial category distribution*

We can translate a sub-category distribution into a super-category distribution by setting the weight of each super-category to the sum of the weights of its sub-categories, which is formally defined by Equation 42.

$$S_{C_j} = \sum_{C_k \in C_j} P(S = C_k) \quad (42)$$

Table 64 illustrates how we map a full category prediction vector into a super-category prediction vector.

<b>Full Distribution</b>		<b>Partial Distribution</b>	
<b>Audio: Music</b>	<b>0.1</b>	<b>Audio</b>	<b>0.6</b>
<b>Audio: OST</b>	<b>0.2</b>	Image	0.0
<b>Audio: Other</b>	<b>0.3</b>	<b>Mixed</b>	<b>0.1</b>
Image	0.0	<b>Software</b>	<b>0.1</b>
<b>Mixed</b>	<b>0.1</b>	Text	0.0
Software: Game	0.0	<b>Video</b>	<b>0.2</b>
<b>Software: Other</b>	<b>0.1</b>		
Text: Book	0.0		
Text: Magazine	0.0		
Text: Other	0.0		
Video: Movie	0.0		
<b>Video: Other</b>	<b>0.2</b>		
Video: TV	0.0		

Table 64: Example of Translating Full to Partial Category Distributions

This procedure could be used to compare classifier agents in terms of super-category prediction should there be a need to.

### 5.3. Comparing MVL and Toran on DS2500 and DS480

Our approach absorbs the knowledge from DS2500 and is validated on DS480. However, these data sets contain items only classified by human experts while the actual categories of the items are unverified. Humans sometimes make mistakes or disagree with each other, which makes the ‘true’ state of these items itself uncertain.

We considered evaluating accuracy for every separate human verdict per torrent item and then taking an average error score. So, for an item with 3 votes we could calculate a score 3 times. This poses a problem for cases where 2 experts classify an item correctly and 1 expert makes a mistake. Effectively, when Toran predicts correctly it is penalised by the wrong human vote. This is illustrated by Table 65, where a single human made a mistake, Toran made a correct prediction and MVL only named the correct super-category. An item like the ones in this table would increase Toran’s total error on the data set by around 0.67.

		Torrent Name				
		Human Verdict	Toran Verdict	Toran Error	MVL Verdict	MVL Error
<b>Example 1</b>	(2010) Кислород [320kbps]					
	Video: Movie	Audio: Music	1.99	Audio	1.49	
<b>Example 2</b>	Dum Maaro Dum - 2011 - Mp3-320-Kbps - Yoge786[www.ahashare.com]					
	Video: Movie	Audio: Music	1.99	Audio	1.49	
<b>Example 3</b>	[ohys] FateKaleid Liner Prisma I1lya - 01 (NICO 720x400 x264 AAC).mp4					
	Video: Other	Video: TV	1.99	Video	1.49	

Table 65: Examples when an Expert is Wrong, MVL Partially is Right and Toran is Correct

We ultimately decided to compare Toran and MVL results to the voice of the majority in the human panel. We pick the estimate of the ‘true’ state of an item according to a classification shared by at least 2 experts. This can either be a full or partial classification. Table 66 illustrates a few examples of working out the category of the item against which MVL and Toran will be evaluated. In DS2500

277 items have a majority super-category only and 194 items are undecided, while for DS480 these figures are 28 and 45 respectively.

<b>Verdict</b>				
<b>Ex.</b>	<b>1</b>	<b>2</b>	<b>3</b>	<b>Derived 'True' State</b>
<b>1</b>	Video	Video	Unknown	Video
<b>2</b>	Video: TV	Unknown	Unknown	N/A
<b>3</b>	Video: Other	Video	Video: Other	Video: Other
<b>4</b>	Software: Game	Unknown	Video: TV	N/A
<b>5</b>	Video: Other	Video: Movie	Video: TV	Video
<b>6</b>	Audio: Music	Unknown	Audio	Audio

Table 66: Deriving a Single Estimate of the 'True' State from Expert Verdicts

Once the single category is determined, we are free to apply any scoring metric in the same way it can be applied for DS120 where the actual item state is verified.

## 5.4. Scoring Metric Requirements

The classification task is essentially two-tiered with first super-category and then its particular sub-category being identified. We need to make sure that the metric we use for evaluation takes account of a correct classification in the super-category even when the sub-category is wrongly identified, e.g. for an item which is a "Video: Movie", the best score should be when it is classified as such. However, being classified as "Video: Other" should be scored better than "Software: Other", or any other equally irrelevant sub-category.

It is also crucial that the metric does not discriminate by super-category size when calculating score for a correct sub-category match. For example, super-categories "Image", "Software" and "Video" contain 1, 2 and 3 sub-categories respectively. Items correctly classified while belonging to any of these categories must be scored exactly the same. In other words, classifying an image correctly should not score better or worse than classifying a movie correctly.

A metric  $M$  must:

- a) be defined to return a non-infinite score for average performance calculation;
- b) be able to handle partial classifications;
- c) behave equally for correct classifications for items in categories of different size;
- d) return best score for an exact match of predicted state and the real state; and the worst score when the prediction matches neither the item's super-category nor the item's sub-category.

## 5.5. Tiered Scoring Rule

In Equation 43 we propose a tiered metric  $MT$  which can extend different classical scoring rules. For this metric we need a probability vector for each of super-category and sub-category predictions. Once one of these is provided by an agent, the second can be derived according to procedures described in Section 5.2. An 'Unknown' verdict can also be used to generate both vectors.

$$MT = \frac{M_1 \times |C_1| + M_2 \times c}{|C_1| + c} \quad (43)$$

Where  $M_1$  is the score calculated for a prediction vector of super-categories,  $|C_1|$  is the count of all sub-categories within the real super category of the item,  $M_2$  is the score calculated for the prediction vector of sub-categories. Variable  $c$  is the coefficient of sensitivity to a full-category score. It allows specifying the significance of the super-category match. In other words, it provides an ability to specify how strongly sub-categories within the same super-category are related. Consider an implementation of this tiered metric  $BST$  based on the Brier score:

$$BST = \frac{BS1 \times |C_1| + BS2 \times c}{|C_1| + c} \quad (44)$$

Where  $BS1$  and  $BS2$  are the super-category and sub-category Brier scores respectively.

To illustrate, consider example 2 from Figure 9 and Table 11. The human votes were “Video: Movie” 2 times and “Video: Other” 1 time for an item which really is “Video: Movie”. We use sensitivity coefficient of 10 for reasons explained later in this section. Table 67 defines each of the components of the  $BST$  equation and other parameters for this instance.

Component	Component Description	Instantiation
$S_{Super}^R$	Real super-category of the item	<i>Video</i>
$S_{Super}^P$	Predicted super-category vector	$\begin{cases} P(S = \text{Audio}) & = 0.0 \\ P(S = \text{Image}) & = 0.0 \\ P(S = \text{Mixed}) & = 0.0 \\ P(S = \text{Software}) & = 0.0 \\ P(S = \text{Text}) & = 0.0 \\ \mathbf{P(S = Video)} & = \mathbf{1.0} \end{cases}$
$S_{Sub}^R$	Real sub-category of the item	<i>Video: Movie</i>
$S_{Sub}^P$	Predicted sub-category vector	$\begin{cases} P(S = \text{Audio: Music}) & = 0.00 \\ P(S = \text{Audio: OST}) & = 0.00 \\ P(S = \text{Audio: Other}) & = 0.00 \\ P(S = \text{Image}) & = 0.00 \\ P(S = \text{Mixed}) & = 0.00 \\ P(S = \text{Software: Game}) & = 0.00 \\ P(S = \text{Software: Other}) & = 0.00 \\ P(S = \text{Text: Book}) & = 0.00 \\ P(S = \text{Text: Magazine}) & = 0.00 \\ P(S = \text{Text: Other}) & = 0.00 \\ \mathbf{P(S = Video: Movie)} & = \mathbf{0.67} \\ \mathbf{P(S = Video: Other)} & = \mathbf{0.33} \\ P(S = \text{Video: TV}) & = 0.00 \end{cases}$
$ C_1 $	Number of sub-categories in the real super-category	3
$c$	Sensitivity coefficient	10
$BS1$	Brier score for $S_{Super}^P$	$5 \times (0 - 0)^2 + (1 - 1)^2 = 0$
$BS2$	Brier score for $S_{Sub}^P$	$(1 - 0.67)^2 + (0 - 0.33)^2 = 0.22(2)$
$BST$	Final tiered Brier score	$\frac{0 \times 3 + 0.22(2) \times 10}{3 + 10} \approx 0.17$

Table 67: Equation Components and Other Parameters for  $BST$  Example,  $c = 10$

This approach works with other metrics such as  $AE$ , so we extend it as  $AE$ . Table 68 provides a summary of resulting  $BST$  and  $AET$  for each of the examples from Figure 9 and Table 11. We also show the relevant score for super and sub-categories for reference. Examples #6 and #8 are treated quite differently by these rules, which is due to the Brier Score penalising a confident wrong prediction while favouring a spread of multiple wrong predictions. Note that the forms  $BS1$  and  $BS2$  refer to the score for super-category and sub-category matches respectively.

Ex.	$AE1$	$AE2$	$AET$	$BS1$	$BS2$	$BST$
1	0.00	0.00	0.00	0.00	0.00	0.00
2	0.00	0.33	0.30	0.00	0.22	0.14
3	0.33	0.33	0.33	0.22	0.22	0.22
4	0.26	0.64	0.61	0.08	0.55	0.37
5	0.51	0.62	0.61	0.33	0.41	0.38
6	0.00	0.67	0.61	0.00	0.67	0.42
7	0.77	0.92	0.91	0.73	0.92	0.85
8	1.00	1.00	1.00	1.33	1.33	1.33
9	1.00	1.00	1.00	2.00	2.00	2.00

Table 68: Calculating  $BST$  ( $c = 5$ ) and  $AE$  ( $c = 30$ ) for Examples in Figure 9 and Table 11

We demonstrate in Table 69 the tiered scoring rule return the same score for a correct classification regardless of the actual super-category size.

Actual State	ACS	Prediction	$AET$	$BST$
Image	1	Image	0.00	0.00
Software: Game	2	Software: Game	0.00	0.00
Video: Movie	3	Video: Movie	0.00	0.00

Table 69: Illustration of Tiered Score Metric Being Non-Discriminative of Super-Category Size

We believe that the tiered metric allows to better approach accuracy estimation in situations items are classified into a hierarchy of multiple labels. The tiered metric satisfies the criteria listed above:

- a) it can extend a metric that is defined within an acceptable range such as Brier score or mean absolute error;
- b) it respects related classes and correctly improves the score by a portion of a match attributed to a related category (as seen in Table 68);

- c) it does not discriminate correct classifications by super-category size (as shown in Table 69);
- d) exact match returns the best score possible while a complete mismatch returns the worst score.

The metric is compatible with the classical scoring rules by decomposing a score produced by such a metric into multiple levels and applying a weight, so the final output is in the same range as output of the classical metric used on the same instance of item classification.

In addition to the characteristics above, this approach is also flexible in allowing us to specify how strongly members of the same super-category are related. The coefficient  $c$  is defined in the range from 0 to positive infinity. Applied to  $BST$ , a higher value of  $c$  results in a score which is closer to  $BS2$  while a lower value makes the score closer to  $BS1$  with the value of 0 making the score equal to  $BS1$ .

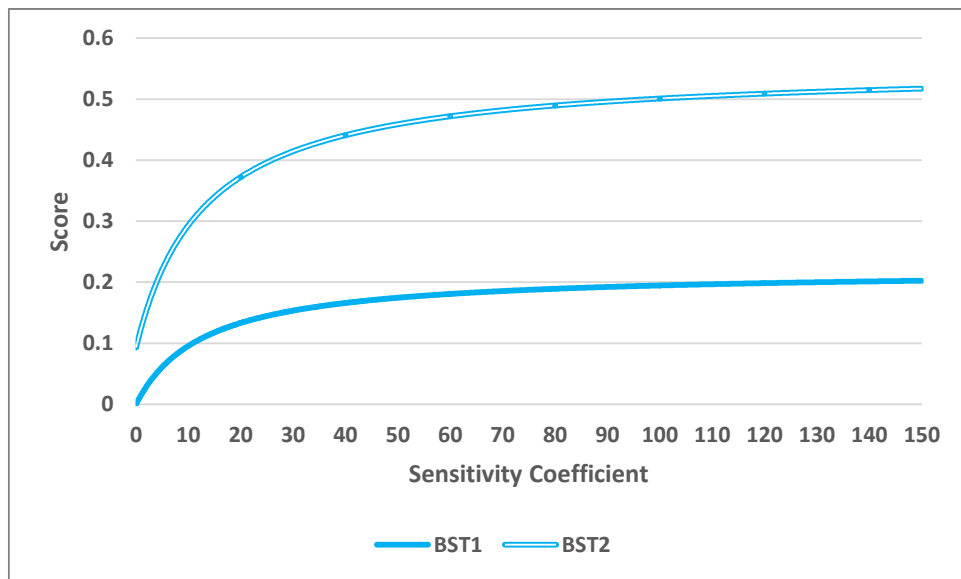

Figure 55: Impact of Coefficient  $c$  on the  $BST$  for Examples #2 and #4 from Figure 9 and Table 11

It needs to be noted that  $c$  loses effectiveness quite sharply around the value of 60. Figure 55 illustrates two arbitrary examples  $BST_1$  ( $BS1 = 0$  and  $BS2 = 0.22$ ), and  $BST_2$  ( $BS1 \approx 0.09$  and  $BS2 \approx 0.55$ ). Lower values of  $c$  make the score tend to  $BS1$  while higher values of  $c$  make the score tend to  $BS2$ .

Formally,

$$\left\{ \begin{array}{l} c \geq 0 \\ c = 0, BST = BS1 \\ c \rightarrow 0, BST \rightarrow BS1 \\ c \rightarrow \infty, BST \rightarrow BS2 \end{array} \right. \quad (45)$$

For results evaluation we calibrated the value of  $c$  for  $BST$  and  $AET$  based on the example predictions from Figure 9 and Table 11, such that they follow associated requirements. For  $BST$  we decided to use  $c = 5$ , because a suitable value of  $c$  ranges from 3.9 to 5.3, and we believe that a considerably bigger weight must be given to a full category match over a partial match. For  $AET$  only  $c = 30$  falls within the constraints associated with Figure 9 and Table 11.

## 5.6. Random Predictions

When evaluating predictions, it is important to consider the score the metric gives to a ‘random’ guess. If a system does not perform better than selecting classes at random then it is inadequate. Considering the Brier score, we may calculate the ‘random’ score when all categories are equally distanced from each other (e.g. a basic ‘Unknown’ distribution), according to Equation 46.

$$BS_{Rand} = 1 - \frac{1}{|C|} \quad (46)$$

Where  $|C|$  is the number of categories. For example, for an item with 13 possible categories and a random prediction of  $1/13$  per category,  $BS_{Rand} \approx 0.92$ . However, when we consider an ‘Unknown’, the estimation of an average ‘random’ score becomes more complex.



Category	Predicted Probability	Item 1 Actual State	Item 2 Actual State	Item 3 Actual State	
Audio: Music	0.06	1			
Audio: OST	0.06				
Audio: Other	0.06				
Image	0.17		1		
Mixed	0.17				
Software: Game	0.08				
Software: Other	0.08			1	
Text: Book	0.06				
Text: Magazine	0.06				
Text: Other	0.06				
Video: Movie	0.06				
Video: Other	0.06				
Video: TV	0.06				
		<b>0.99</b>	<b>0.76</b>	<b>0.93</b>	<b>Brier Score</b>

Table 70: Possible Brier Score for ‘Unknown’ Predictions Depending on the True Item State

Table 70 demonstrates that Brier Score for a prediction with a priored ‘Unknown’ distribution results in very different scores depending on the real state of the item, which should not be the case.

A further complication is using a tiered Brier score as defined in Equation 44, which aims to reward predictions within the same super-category even if the sub-category does not match. We empirically define a random *BST* by scoring a large number of randomly generated combinations of prediction vectors and true item states. To be exact, the following steps are repeated 10,000,000 times and an average is calculated:

- 1) Pick random super-category  $C$
- 2) Pick random sub-category  $c \in C$
- 3) Fill a prediction vector  $S$  with random numbers and normalise
- 4) Calculate  $BST(c, S)$

The resulting average *BST* for random predictions is 0.923, which is the same as for a random prediction according to a regular Brier score. We can use this number

as a very basic benchmark for a method viability. If the final score of a classifying agent is close to this figure, then the predictions are little better than random.

## 5.7. Summary

In this chapter we introduced a coherent framework for comparing results of different types provided by different classifying agents and systems. We identified a set of requirements that a metric should sensibly satisfy to work in a multi-class hierarchical setting and suggested an extension to classical metrics that addresses this issue and explained in detail justification for this extension and its parameters.

# Chapter 6

## Empirical Evaluation and Analysis

This chapter provides an in-depth analysis and comparison of results achieved by our system *Toran*, the MovieLabs benchmark system *MVL* and the human panel (*HP*). It addresses *Research objective 2* in Section 6.1 by showing that title matching improves classification results and estimation of probability of fakes and malware. It addresses *Research objective 4* by providing assessment of the results in comparison between classifying agents on multiple data sets. DS2500 and DS480 provide the basis for preliminary testing on non-verified data, pre-classified only by humans. DS120 is the general-purpose testing set, while DSFM is specifically concerned with the ability to capture fakes and malware. DSBS is a sequential set of newly posted torrent records from BitSnoop online feed – to test our methodology in vivo. These data sets including results of all agents are available in Appendix D.

This chapter considers performance of the four agents:

- the human panel *HP*;
- the MovieLabs benchmark system *MVL*;
- our system *Toran* (with title matching turned off);
- our system *Toran T* (with title matching turned on).

Throughout the chapter we accept a confidence interval of 95% and margin of error is identified following classification error figures in the form  $e \pm m$ , where  $e$  is the value of a classification error metric and  $m$  is the statistical margin of error, which is calculated according to:

$$\begin{aligned}
m &= z \cdot SE \\
SE &= \frac{s}{\sqrt{n}} \\
s &= \sqrt{\frac{\sum_{i=1}^n (e - e_i)^2}{n - 1}}
\end{aligned}
\tag{47}$$

where  $z$  is the critical value associated with the chosen confidence interval (1.96 for 95%),  $SE$  is the standard error of the mean,  $n$  is the number of items averaged,  $s$  is the sample standard deviation,  $e$  is the mean classification error and  $e_i$  is an individual item's classification error.

We use a combination of Brier score and absolute error as defined in Section 2.6.4, to evaluate the quality of our probabilistic predictions in Section 6.1. These metrics were selected because they address different aspects of classification analysis: the Brier score puts a higher emphasis on the spread of the wrong portion of a prediction, while absolute error is more concerned with the confidence of correct portion of the prediction. We complement evaluation by extending these metrics to their tiered versions as defined in Section 5.5, which addresses the issue of related classes in the taxonomy, and produce improved scores when a prediction is only partially correct, compared to a completely wrong prediction.

We then consider how agents misclassify items and show how categories are mistaken for other categories in Section 6.2.

We also consider an interpretation of the results where the top predicted category is selected as a hard verdict. In Section 6.3 we compare these hard choices directly to expert and MVL verdicts in terms of accuracy as defined in Section 2.6.3.

We then compare Toran and MVL performance in Section 6.3.2 on an independent sample collected from a popular torrent tracker (BitSnoop 2015) by combining all scoring techniques used in previous sections.

While most of this chapter is concerned with medium classification, Sections 6.5 and 6.6 evaluate the ability of Toran, MVL and humans to detect porn, fakes and malware.

## 6.1. Assessment of Probabilistic Predictions

This section is focused on evaluating performance in terms of the error metrics Brier score and mean absolute error, and their extended tiered versions. Parameters used for calculating predictions and evaluation scores are defined in Table 71.

Parameter	Value
BST coefficient $c$	5
MAET coefficient $c$	30
n-gram pre-filtering score threshold $\tau_G$	0.5
Title match threshold $\tau_I$	0.95

Table 71: Prediction and Evaluation Parameters

This section first provides an overview of Toran’s performance during preliminary testing on DS2500 and DS480 in comparison to MVL in Sub-section 6.1.1, while the actual testing on DS120 is covered in Sub-section 6.1.2.

### 6.1.1. Knowledge and Validation Sets

Our methodology is informed to a great degree by the data we studied in DS2500. However, it is important to note that humans sometimes make mistakes and therefore a classifier ideally trained to mimic human experts will be prone to the same type of errors, so we did not specifically aim to achieve zero error for these sets.

As these data sets contain items that are not verified, we perform evaluation on the assumption that categories decided by the human majority are the actual classifications of items. This assumption is a compromise to allow us to obtain a

general idea of Toran and MVL performance before testing them on other data sets. Items, for which this human approximation of the actual state is undefined, are skipped from error calculation.

Set	Agent	Error			
		<i>BS</i>	<i>BST</i>	<i>MAE</i>	<i>MAET</i>
DS2500	MVL	0.56 ±0.03	0.45 ±0.03	0.37 ±0.02	0.35 ±0.02
	Toran T	0.44 ±0.03	0.36 ±0.02	0.34 ±0.02	0.33 ±0.02
DS480	MVL	0.63 ±0.07	0.49 ±0.06	0.43 ±0.04	0.40 ±0.04
	Toran T	0.51 ±0.06	0.40 ±0.05	0.40 ±0.04	0.38 ±0.04

Table 72: Average Error of MVL and Toran T on DS2500 and DS480 with 95% Confidence Interval

Table 72 considers average medium classification error, so the lower number indicates the better prediction. Note that over a set of items *AE* and *AET* become *MAE* and *MAET*. DS2500 provides more reliable results due to increased sample size compared to DS480. One of the key observations here is that **MVL benefits more from using a tiered metric** (for example, the error drops from 0.56 to 0.45 *BS* in DS2500 while for Toran it only drops from 0.44 to 0.36). This is because MVL often (over 35% of times) returns only a partial classification or an “Unknown”, which spreads the weight of the prediction over multiple categories. The tiered metric rewards predictions that fall into the same super-category as the actual class, therefore a partial prediction, given that it picks the correct super-category, naturally benefits from this way of scoring. Effectively, **the difference between regular and tiered metrics demonstrates how likely an agent is to pick a wrong sub-category within the correct super-category**.

Another observation from Table 72 is that **Toran seems to score better with *BS* rather than *MAE*** (e.g. *MAET* for DS480 is much more similar between Toran and MVL than *BST*). A possible reason for this is that, even when classifying correctly, Toran will often not assign a whole 100% chance to the correct category. For example, a probability of 0.9 towards “Video: Movie” is a very strong probability

and we may interpret it as Toran classifying an item as a movie, however *MAE* will consider this as 0.1 error.

		Error	
Set	Agent	<i>BST</i>	<i>MAET</i>
DS2500	Toran	0.26 ±0.03	0.28 ±0.02
	Toran T	0.23 ±0.03	0.23 ±0.02
DS480	Toran	0.30 ±0.06	0.32 ±0.05
	Toran T	0.25 ±0.06	0.27 ±0.05

Table 73: Title Matching Improves Results for Movies, TVs and Games in DS2500 and DS480

Table 73 shows the effect of enabling title matching in DS2500 and DS480 with 95% confidence level. This table uses the same item sets as Table 72, but restricted only to items identified by humans as games, movies and TVs, which are the categories where title data is available. We note that **there is a small improvement in classifying items when an external title database is used**, which demonstrates the potential of title matching. We believe that a better quality database of titles may yield a further improvement, which is noted in the Future Work Section 7.3.

### 6.1.2. DS120: Test Set

Classification of items in DS120 is the test which allows us to compare automated systems against human experts and establish the general accuracy of human experts themselves. Comparing results to the actual state of the items instead of expert impression of it is the most conclusive way of calculating accuracy of a classification agent.

		Error			
		<i>BS</i>	<i>BST</i>	<i>MAE</i>	<i>MAET</i>
Agent	HP	0.30 ±0.08	0.24 ±0.06	0.38 ±0.05	0.37 ±0.05
	MVL	0.64 ±0.13	0.49 ±0.11	0.43 ±0.08	0.41 ±0.07
	Toran T	0.46 ±0.10	0.38 ±0.08	0.40 ±0.06	0.38 ±0.06

Table 74: Average Error of HP, MVL and Toran T on DS120

One of the drawbacks of DS120 is the small sample size, which drastically hampers confidence in attained accuracy figures. The results shown in Table 74 **indicate that Toran is a viable classification engine** and performs only slightly worse than humans according to *MAET* (e.g. humans and Toran show  $0.37 \pm 0.05$  and  $0.38 \pm 0.06$  error respectively). Interestingly, the Brier score indicates that **Toran and especially MVL sometimes strongly misclassify items within the correct super-category** on a few occasions (e.g. *BS* 0.64 for MVL dropping to 0.49 *BST* and 0.46 to 0.38 for Toran). This may happen, for example, when the item name contains sufficient super-category but little sub-category specific evidence.

One of the surprising findings revealed by this experiment was an **unexpectedly large error of the collective human classifiers** (e.g.  $0.37 \pm 0.05$  according to *MAET*). This is crucial as it shows that it is infeasible to train a classifier solely on human-processed data, as it would inherit the non-ideal performance of humans.

		Error	
		<i>BST</i>	<i>MAET</i>
Agent	Toran	$0.32 \pm 0.11$	$0.34 \pm 0.09$
	Toran T	$0.28 \pm 0.10$	$0.32 \pm 0.08$

Table 75: Title Matching Improves Results for Movies, TVs and Games in DS120

Table 75 shows that **there is potential for improving classification results by title matching**, but error difference is very small and sample size does not allow us to make strong conclusions.

## 6.2. Confusing Predictions

A confusion matrix (Congalton & Mead 1983) visualises classification results and makes it easy to identify categories that attract false positives. Note that we only include items for which a full category is known in DS120 or assumed by human expert majority in DS480 and DS2500. Therefore, 73 and 471 items are not included in the confusion matrices from DS480 and DS2500 respectively. Each row



represents an average prediction that is assigned to an item that actually belongs to the row's category, therefore values in each row add up to 1. An ideal classifier would have no false positives, and therefore its confusion matrix would show a simple filled diagonal.

		DS2500											DS480													
		Predicted Category																								
		Video: TV	Video: Other	Video: Movie	Text: Other	Text: Magazine	Text: Book	Software: Other	Software: Game	Mixed	Image	Audio: Other	Audio: OST	Audio: Music	Video: TV	Video: Other	Video: Movie	Text: Other	Text: Magazine	Text: Book	Software: Other	Software: Game	Mixed	Image	Audio: Other	Audio: OST
Actual Category	Audio: Music																									
	Audio: OST																									
	Audio: Other																									
	Image																									
	Mixed																									
	Software: Game																									
	Software: Other																									
	Text: Book																									
	Text: Magazine																									
	Text: Other																									
	Video: Movie																									
	Video: Other																									
	Video: TV																									
	MVL																									
	Actual Category	Audio: Music																								
		Audio: OST																								
		Audio: Other																								
		Image																								
		Mixed																								
		Software: Game																								
		Software: Other																								
		Text: Book																								
		Text: Magazine																								
		Text: Other																								
Video: Movie																										
Video: Other																										
Video: TV																										
Toran T																										

Figure 56: Medium Confusion Matrices for DS2500 and DS480

Figure 56 compares category confusion of Toran and MVL on DS2500 and DS480 sets. Both systems have a few things in common. Notably, many non-video items are predicted to be videos, as well as many text items in DS2500 are misclassified (i.e. wrongly predicted) to be specifically books, just like many audios are misclassified as specifically music. This is likely to happen due to prior expectations of both systems. For example, most items are videos, so when there is a lack of evidence found in the name string, both Toran and MVL might consider

it to be a video. When there is evidence of a text item but not any specific text category, both systems are likely to guess the item is a book. More subtle differences include Toran misclassifying audio items as videos and text items as software more often than MVL.

Figure 57 extends the above analysis by providing confusion matrices for DS120 set for humans, MVL and Toran, which allows us to look into human misclassification habits. Humans classify most items correctly, however they misclassify many items of different categories as videos. This may be due to a strong prior humans have for an arbitrary item to be a video. They also seem to misclassify “Audio: Other”, perhaps due to poor naming of such items and confusion of audio books with text books and radio shows with TV shows.

A proportion of “Image” is confused with “Video: Other”, perhaps, due to mistaking a collection of porn pictures for a porn video. “Image” is also sometimes confused to “Software: Other” in cases of 3D modelling or image processing software.

“Text: Book” can sometimes be misclassified as “Audio: Music” in cases of lyrics collections, or with “Image” in case of comic books. “Text: Magazine” is generally difficult for classification as the file name may simply contain a title of the magazine or a part of it.

“Video: Movie” is sometimes confused with “Video: Other”, especially in cases of porn movies which may not necessarily be listed on databases like IMDb, yet are released as full-length movies. “Video: TV”, on the other hand, may be confused with “Video: Other” in cases of TV periodic show being misclassified as a one-off programme.

Confusion matrices in Figure 57 show that **humans are less likely to misclassify items compared to MVL or Toran**. Visually, the diagonal produced by humans is more intensive and Toran’s diagonal is visually more complete than MVL’s due to

being more likely to correctly classify soundtrack, software applications and magazines, so **Toran** is less likely to misclassify items than MVL.

		Predicted Category													
		Audio: Music	Audio: OST	Audio: Other	Image	Mixed	Software: Game	Software: Other	Text: Book	Text: Magazine	Text: Other	Video: Movie	Video: Other	Video: TV	
Actual Category	Audio: Music	■													
	Audio: OST		■												
	Audio: Other	■							■						
	Image				■										
	Mixed														
	Software: Game						■								
	Software: Other						■								
	Text: Book							■							
	Text: Magazine								■						
	Text: Other									■					
	Video: Movie										■				
	Video: Other										■				
	Video: TV											■			
	<b>HP</b>														
	Actual Category	Audio: Music	■												
Audio: OST		■													
Audio: Other		■													
Image					■										
Mixed															
Software: Game							■								
Software: Other							■								
Text: Book								■							
Text: Magazine									■						
Text: Other										■					
Video: Movie											■				
Video: Other											■				
Video: TV												■			
<b>MVL</b>															
Actual Category		Audio: Music	■												
	Audio: OST		■												
	Audio: Other	■													
	Image				■										
	Mixed														
	Software: Game						■								
	Software: Other						■								
	Text: Book							■							
	Text: Magazine								■						
	Text: Other									■					
	Video: Movie										■				
	Video: Other										■				
	Video: TV											■			
	<b>Toran T</b>														

Figure 57: Medium Confusion Matrices for DS120

It has to be noted though that this analysis may not allow us to draw very strong conclusions due to the small size of DS120, but still provides valuable insight into capabilities of the three classifying agents.

### 6.3. Evaluation in Terms of Accuracy

In this section we consider the relative accuracy of the different agents when they are forced to provide an explicit decision about an item. A simple approach to select a hard prediction is to pick the top predicted category out of the whole prediction vector. We can calculate values of *true positives* (TP), *true negatives* (TN), *false positives* (FP) and *false negatives* (FN) and derive from them the associated values  $\rho$ ,  $\pi$ ,  $\alpha$ ,  $F_1$ , and  $MCC$  as described in Section 2.6.3.

Each category has its own TP, FP, TN and FN counters. The following procedure is applied to determine these values for a single item:

- 1) All categories that are not the true state of the item  $S_R$  nor are the highest predicted category  $S_P$ , have their TN incremented.
- 2) If the true state of the item  $S_R$  matches  $S_P$ , category  $S_R$  has its TP value incremented.
- 3) If  $S_R$  does not match  $S_P$ , then  $S_R$  has FN and  $S_P$  has FP values incremented.
- 4) If  $S_P$  is a set of equally predicted top categories, then they all have FP incremented, except for  $S_R \in S_P$  when  $S_R$  has TP incremented instead.  
If  $S_R \notin S_P$  then  $S_R$  has FN incremented.

We effectively reduce the multiclass classification problem down to a binary classification for each individual category. However, we also combine the results by summing up TP, FP, TN and FN values per each agent to calculate average performance metric on the complete data set.

### 6.3.1. Accuracy Metrics

Due to the multi-class nature of medium category being predicted, FP is always equal to FN in this section. A single correct classification results in 1 TP and 12 TN, while a misclassification is 1 FP, 1 FN and 11 TN. This can be illustrated by Table 76. This in turn means that recall  $\rho$  is equal to precision  $\pi$  and also equal to  $F_1$  score.

Set	Agent	TP	FP	TN	FN
DS2500	MVL	1,254	775	23,573	775
	Toran T	1,425	604	23,744	604
DS120	HP	97	24	1,428	24
	MVL	68	53	1,399	53
	Toran T	80	41	1,411	41

Table 76: Data for Average Accuracy on DS2500 and DS120

We can reason about the results in a basic way by looking at the absolute number of correctly predicted actual categories (TP) and those that were failed to be correctly predicted (FN), which is equal to recall (see Table 77).

Set	Agent	Accuracy Metrics				
		$\rho$	$\pi$	$\alpha$	$F_1$	$MCC$
DS2500	MVL	0.62	0.62	0.94	0.62	0.59
	Toran T	0.70	0.70	0.95	0.70	0.68
DS120	HP	0.80	0.80	0.97	0.80	0.79
	MVL	0.56	0.56	0.93	0.56	0.53
	Toran T	0.66	0.66	0.95	0.66	0.63

Table 77: Average Accuracy on DS2500 and DS120

Interestingly, accuracy  $\alpha$  seems to be quite strong according to these metrics, but this is due to an extremely large number of TNs. In these conditions it may be sensible to judge performance by  $MCC$ , which is specifically balanced to deal with classes of considerably different sizes. **Toran seems to perform better than MVL but worse than humans according to accuracy metrics.** However, one of the primary objectives of MVL was to quantify the uncertainty associated with

classification, so it is unsurprising that it performs relatively poorly when forced to provide a ‘certain’ classification.

### 6.3.2. Receiver Operating Characteristic (ROC)

A popular method of assessing performance of a classifier is via the Receiver Operating Characteristic (ROC) curve graphs (Fawcett 2006), which are created by plotting the True Positive Rate (TPR) against the False Positive Rate (FPR), which are defined in Equation 48.

$$\begin{aligned} TPR &= \frac{TP}{TP + FN} \\ FPR &= \frac{FP}{FP + TN} \end{aligned} \tag{48}$$

For each curve on the ROC graph, TPR and FPR are calculated given a specific threshold  $\tau$  of confidence of the classifier’s decision. For example, with  $\tau = 0.7$  only a class with predicted probability of 0.7 or stronger would be accepted as a positive classification, while with  $\tau = 0.1$  there can be many labels accepted as positives. We calculate points for values of  $\tau$  from 0 to 1 in increments of 0.001. The bottom-left corner of the graph corresponds to  $\tau = 1$ , which means that only predictions of 100% confidence are taken as positives, hence low number of TP and FP. The top-right corner corresponds to  $\tau = 0$  where any prediction is taken as a positive; therefore all possible classes are either TP or FP.

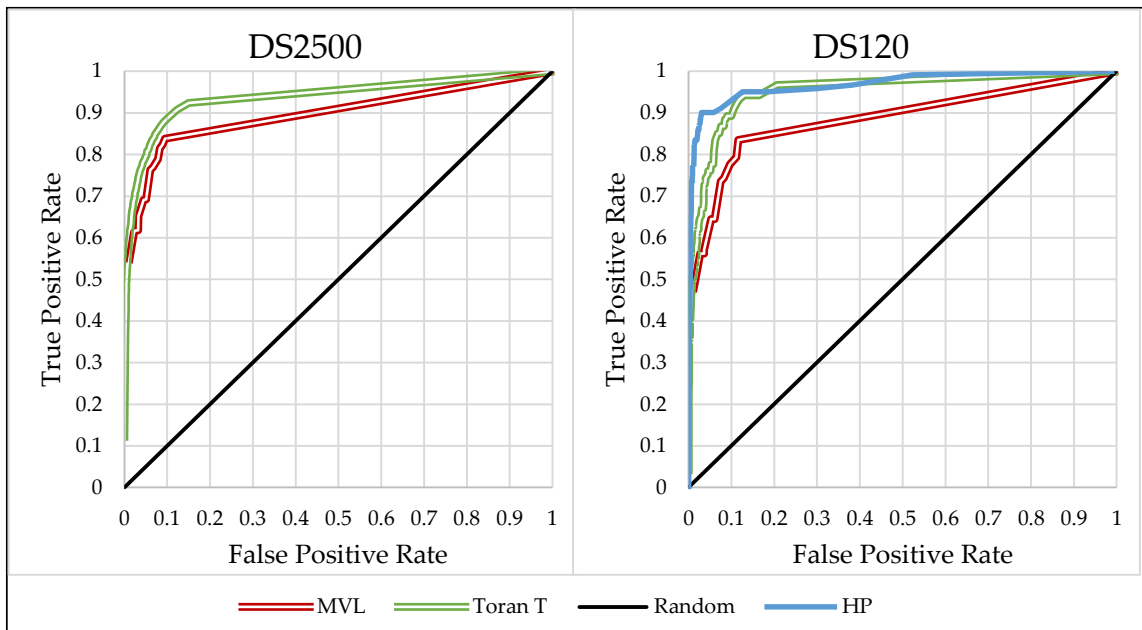

Figure 58: ROC Curves for Medium in DS2500, DS480 and DS120 by All Agents

Figure 58 demonstrates ROC curves for medium in DS2500 and DS120. The ‘Random’ line dividing the graph in half represents an agent classifying items at random. The further a ROC curve is from this line the better are the predictive qualities. In this figure, for example, the best predictor is the humans on the DS120 sample. In general, the results reflected by the ROC graphs correspond with other metrics – **humans perform the best, closely followed by Toran and then MVL.**

The sharpness of the MVL curve is due to low granularity of possible levels of confidence, where each verdict is one of the following: unknown, partial and full medium. When translated into a probability vector as per Section 5.2, it results in a limited possible number.

An additional use of ROC graphs is that we may find a point for each agent that is furthest from the ‘Random’ line. The threshold value associated with this point would be optimal. In our application, the optimal threshold happens to be the same as if we always picked the top predicted category as the hard choice. However, it is possible to devise more complex rules for selecting the top category, based on some utility value, for example.

The area under the ROC curve (AUROC or AUC) is a popular assessment metric (Flach et al. 2011), which is an aggregated measure of classification performance and combines all possible decision thresholds. It estimates the probability that the classifier will rank a random positive item higher than a random negative item – for example, the chance that a random porn video is classified as porn with a higher confidence than a random non-porn video. Essentially, AUC equal to 1 means perfect classification and 0.5 means no better than random. AUC less than 0.5 means worse than random, but for binary classification may allow the classifier’s decisions to be inversed and thus achieve better prediction quality.

Though AUC is normally calculated by integration, in our case we may use the trapezoidal rule as per Equation 49 to approximate such definite integral.

$$AUC = \frac{h}{2} \sum_{i=1}^N (f(x_{i+1}) + f(x_i)) \quad (49)$$

where  $N$  is the number of points and  $h$  is the increments of  $x$ . Variable  $x$  refers to FPR and  $f(x)$  refers to TPR.

		Agent		
		HP	MVL	Toran T
Data Set	DS120	0.97 ±0.09	0.88 ±0.09	0.95 ±0.09
	DS2500	-	0.89 ±0.03	0.94 ±0.03

Table 78: AUC for Porn and Medium for All Agents on all Data Sets

Table 78 shows AUC calculated for medium predictions on DS2500 and DS120 for all agents and margin of error shown is based on sample sizes, uniform sample proportion and confidence interval of 95%. **In medium classification Toran provides results better than MVL and only slightly worse than humans.** We believe that, in combination with other metrics, AUC can serve as an additional indicator of results quality.



## 6.4. BitSnoop Experiment

The BitSnoop data set is very important to us for two reasons. Firstly, it is sufficiently large to be able to make strong conclusions from it, and secondly it draws items from a source, independent from MovieLabs, and its data was not involved in building Toran in the first place.

Table 79 provides average error for Toran and MVL on DSBS. Note that margin of error is considerably smaller than for other sets. Both classifiers have a much smaller error than for other sets, which is due to DSBS being composed of mostly movies and TVs, with a much smaller proportion of music, books and software.

Items belonging to these categories normally have sufficient evidence in the name string, and are therefore easier for Toran and MVL to classify than items of other categories that lack such an abundance of category-specific evidence.

		Error			
		<i>BS</i>	<i>BST</i>	<i>MAE</i>	<i>MAET</i>
Agent	MVL	0.384 ±0.006	0.337 ±0.005	0.298 ±0.004	0.285 ±0.004
	Toran	0.269 ±0.005	0.209 ±0.004	0.231 ±0.003	0.218 ±0.003
	Toran T	0.268 ±0.005	0.208 ±0.004	0.217 ±0.003	0.205 ±0.003

Table 79: Average Error Metrics per Agent in BitSnoop Data Set

We can see from the difference between *BS* and *BST* that agents misclassify some items within the correct super-categories, giving a strong probability to the wrong sub-category. However, judging by a smaller difference between *MAE* and *MAET*, we may conclude that it does not happen too often (otherwise the error would likely be higher). A possible reason for this is that most items are named in a way that there is sufficient evidence to make a strong prediction rather than a spread of weaker probabilities. In general, **Toran performs better than MVL by at least 7% according to *MAET* difference between lowest MVL and highest Toran T error.** We can also see clearly that **title matching further improves Toran results** (0.218 ±0.003 *MAET* without and 0.205 ±0.003 with title matching). Note that the effect of

title matching is virtually insignificant according to *BST*, because most items in the data set contain a lot of secondary medium information in the torrent names, which is sufficient to correctly classify an item with a strong probability (e.g. 0.9). However, such a prediction may return a very small *BST* error when other categories are distributed more or less evenly, while *MAET* would return a value close to 0.1. Yet, enabling title matching may result in a much stronger prediction (i.e. closer to 1), thus dramatically reducing *MAET*.

		MVL							Toran T							
		Predicted Category														
		Audio: Music	Image	Software: Game	Software: Other	Text: Book	Video: Movie	Video: Other	Video: TV	Audio: Music	Image	Software: Game	Software: Other	Text: Book	Video: Movie	Video: Other
Actual Category	Audio: Music	■							■							
	Image		■							■						■
	Software: Game			■			■				■					■
	Software: Other				■		■				■					■
	Text: Book					■						■				
	Video: Movie						■						■			
	Video: Other							■						■		
	Video: TV								■							■

Figure 59: Confusion Matrices for BitSnoop Data Set

Figure 59 show confusion matrices for BitSnoop data set. Note that only relevant categories are displayed. Both MVL and Toran seem to be good at classifying music, movies and TVs. Toran misclassifies some images as TVs and many games as applications. However, unlike MVL, Toran misclassifies fewer “Video: Other” as movies or TVs. MVL misclassifies a lot of items as movies and, to a smaller extent, TVs, which is likely due to its prior. Both Toran and MVL misclassify some games, movies and other videos as TVs. In general, **Toran’s confusion matrix is visually closer to a diagonal than the one produced by MVL**, but it is evident that there is ample room for improvement.

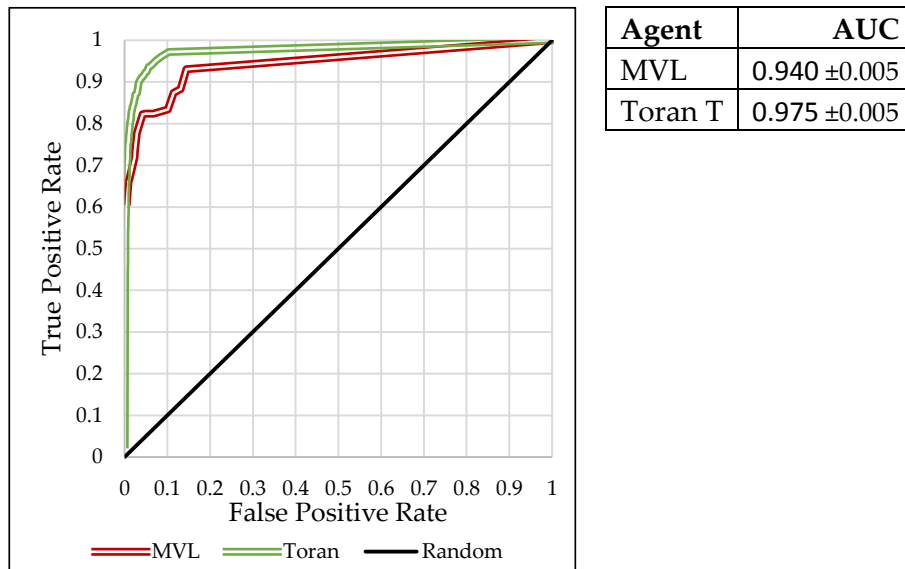

Figure 60: ROC Graph and AUC for BitSnoop Data Set

According to the ROC graph from Figure 60, **Toran clearly shows better performance than MVL**. According to AUC, **Toran’s performance is better by at least 2.5%**.

The results achieved on an independent data set for which Toran was not attuned to, demonstrate that the methodology provides a feasible coherent framework and can work outside of the laboratory environment.

The BitSnoop study conclusively demonstrates that our classification framework can successfully rival contemporary industrial standards and may be used on data that it was not specifically designed to work with.

## 6.5. Porn Detection

Porn detection is a binary problem, so it is best suited to be evaluated in terms of accuracy. However, *MAE* is also a viable option.

Set	Agent	TP	FP	TN	FN
DS2500	MVL	112	6	1,885	169
	Toran T	205	13	1,878	76
DS120	HP	34	1	84	2
	MVL	11	0	85	25
	Toran T	22	2	83	14

Table 80: Data for Porn Detection Accuracy

Table 80 shows the raw observations about porn detection assuming the top predicted category as a hard verdict. We notice that Toran picks up around twice as many porn items as MVL. Both agents are very accurate about the items picked, but fail to detect a lot of items.

Set	Agent	Accuracy					Error
		$\rho$	$\pi$	$\alpha$	$F_1$	$MCC$	$MAE$
DS2500	MVL	0.57	0.84	0.75	0.68	0.51	0.38 $\pm$ 0.08
	Toran T	0.30	0.64	0.60	0.41	0.19	0.29 $\pm$ 0.08
DS120	HP	0.94	0.97	0.98	0.96	0.94	0.13 $\pm$ 0.03
	MVL	0.31	1.00	0.79	0.47	0.49	0.21 $\pm$ 0.07
	Toran T	0.61	0.92	0.87	0.73	0.67	0.19 $\pm$ 0.07

Table 81: Porn Detection Accuracy and Error

Table 81 shows accuracy metrics and mean absolute error for porn detection in DS2500 and DS120. Note that a normal version of *MAE* is used because there are no category levels involved. It is coherent with Table 80 in **Toran having a lot higher recall than MVL** (1.8 times in DS2500 and almost 2 times in DS120). *MAE* is relatively high compared to accuracy values in DS120, which suggests that some correct predictions were not very confident. Based on the metrics above (e.g.  $F_1$ , or  $MCC$ ), humans are very good in identifying porn items, followed by **Toran**,

which is better than MVL (almost twice better TP and FN,  $F_1$  and  $MCC$  being higher by more than 0.2). While the size of DS120 limits the strength of conclusions, we may still be confident that Toran is a viable porn detection system, albeit with room for improvement.

## 6.6. Fakes and Malware

Detecting fakes and malware is also a binary problem, so we evaluate it in terms of accuracy and  $MAE$ .

	Agent	TP	FP	TN	FN
Fakes	HP	14	8	46	32
	Toran T	26	5	49	20
Malware	HP	7	1	76	16
	Toran T	6	2	83	14

Table 82: Data for Fake and Malware Detection Accuracy

Table 82 shows the raw observations about fake and malware detection assuming the top predicted category as a hard verdict. Humans and Toran seem to have a similar rate of false positives, but Toran identifies almost twice as many fakes as humans and about the same number of malware items. A large proportion of items remain undetected by both agents (more than two thirds for humans and about half fakes and two thirds malware for Toran), so there is a considerable room for improvement. We believe that a well maintained list of titles, as well as the risk group, may further improve results demonstrated in this section.

		Accuracy					Error
Agent		$\rho$	$\pi$	$\alpha$	$F_1$	$MCC$	$MAE$
Fakes	HP	0.30	0.64	0.60	0.41	0.19	0.38 $\pm$ 0.08
	Toran T	0.57	0.84	0.75	0.68	0.51	0.29 $\pm$ 0.08
Malware	HP	0.26	1.00	0.83	0.41	0.46	0.17 $\pm$ 0.07
	Toran T	0.30	0.88	0.83	0.45	0.45	0.18 $\pm$ 0.07

Table 83: Fake and Malware Detection Accuracy and Error

Table 83 shows accuracy metrics and mean absolute error for DSFM set. We note that **recall is poor for both agents**, although precision is better, especially for malware. Although the size of this set does not allow us to draw very strong conclusions, **the potential is clear for Toran to operate on par with or even better than humans in fake and malware detection.**

## 6.7. Summary

This chapter concluded the classification and evaluation parts of the thesis and presented a detailed evaluation of classification and identification results. We showed that Toran generally matches and sometimes outperforms MVL in medium classification and porn identification and is closer in results to humans than to MVL. Unlike MVL, Toran is capable of predicting fakes and malware in addition to its primary functionality.

We applied a range of assessment techniques and metrics to the results to ensure that our conclusions are not biased towards a particular accuracy measurement method. We measured error by Brier score and mean absolute error, including our proposed extension to these error metrics that allow capturing the proportion of a prediction assigned to a wrong sub-category within a correct super-category. We used confusion matrices to show in detail how different agents misclassify categories. We also evaluated accuracy in terms of recall, precision, accuracy, *F1* score, and Matthews correlation coefficient, based on the number of true and false positives and negatives, having the top predicted category of a classifying agent taken as a hard verdict. We used ROC graphs to compare performance of different classifying agents given different thresholds of verdict confidence acceptance and gave relevant AUC values. We provided margin of error for applicable metrics for confidence level of 95%.

Smaller test sets are unsuitable to making strong conclusions but they provide us with a proof of viability of the Toran prototype system and demonstrate that it has

a solid potential. The bigger BitSnoop data set allows making strong conclusions and we observe that **Toran, in fully autonomous mode, is able to outperform the benchmark MVL system in medium classification** (see Table 79 and Figure 60). Note that MVL combines analysis of file name and size with title information, meta-data at the torrent publication source and is also able to scan the torrent content's manifest, which may provide a deeper understanding of the file's content. These capabilities require regular maintenance yet a fully unsupervised Bayesian Toran system was able to compete with MVL.

In summary, we used DS2500 and DS480 for preliminary testing and to prove the method's viability. DSFM was used to demonstrate that Toran can compete with human classifiers in identifying fakes and malware. BitSnoop data set provided us with an opportunity to definitively conclude that Toran can perform on par or better than a commercial benchmark system, with a very small margin of error (below 0.005).

# Chapter 7

## Summary and Conclusions

In this thesis we addressed the problem of identifying and classifying generic Internet media content in the absence of informative data such as meta-tags. In Chapter 1 we explained the important need for such identification and classification in the context of BitTorrent files that contribute a large proportion of global Internet traffic, yet are mostly analysed in terms of general volume. The sharing and downloads of BitTorrent files has major financial, legal and security implications, and there is an urgent need for different organisations and users to learn about the content of the files, but typically only the file name and size are available. Being able to process ill-formed user-generated file names is the key to enabling richer analysis of torrent data.

In this context, and also taking account of a virtual absence of sufficient verified data samples for training, validation and testing in a classical frequentist approach, we argued that a Bayesian framework of identification and classification should be used, because it allows us to incorporate expert judgment with limited data in order to characterise the inherent uncertainty of such classification.

Section 7.1 provides an example of the complete methodology applied to a torrent item, including how we would logically reason about evidence in the name string, how the evidence is translated into BN observations and the final results calculated by the model. In Section 7.2 we review the progress made in terms of research objectives and give a summary of various sections and chapters addressing these objectives. Section 7.3 lays out the prospects for future work, focusing not only on improving the framework in general and Toran implementation in particular, but also on possible ways of improving evaluation of multi-category hierarchical classification solutions. In Section 7.4 we reflect on the work described in this thesis



and gives a few examples of instantiating our general framework in other application domains.

## 7.1. Methodology

We approached the problem by developing a comprehensive Bayesian Network model (see Chapter 3) that relies on:

- Torrent size
- Detection of a movie, game or TV series title in the file name
- Detection of medium-specific and other evidence in the file name

We collected and studied a large sample of torrent files that, together with domain experts, informed the model structure and parameters including prior probabilities. We used several other samples for validation and testing (see Section 2.5). While building the model we conducted several studies into the online content in order to refine our prior beliefs and domain knowledge.

We applied a range of information retrieval and string processing techniques to extract evidence from file names, involving sequence alignment, n-gram and regular expression matching (see Chapter 4). We defined a flexible framework that allows updating and modification of the current configuration, such that new knowledge may be incorporated easily (see Sections 3.13 and 4.5).

To illustrate how our methodology is applied to classify a torrent item, and what reasoning goes into the process consider the example shown in Figure 61.

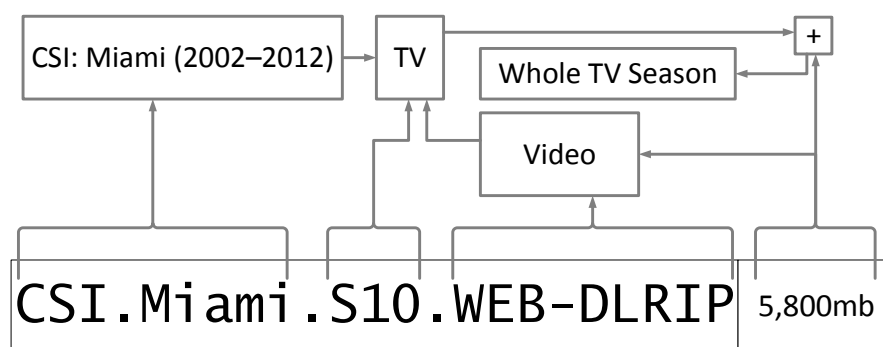

Figure 61: Interpretation of Evidence in CSI.Miami.S10.WEB-DLRIP Torrent

This illustrates a torrent with name `CSI.Miami.S10.WEB-DLRIP` of size 5,800MB and demonstrates a human thought-process of identifying and classifying this torrent. Our method attempts to mimic such reasoning.

The main task is to extract as much evidence from the torrent and use it as observations in the classifier BN model defined in Chapter 3. We begin by entering the file size into the model. The size 5,800MB is a size most expected for “Video: Movie” or to a lesser degree for “Software: Game” (as explained in Section 3.8 for conditional priors of file size). Other evidence we enter into the BN will refine our posterior belief about this. We run the torrent name through our list of signatures which are associated with one or more medium category (as was explained in Section 4.3). Each detected signature has semantical meaning and we enter cumulative strength of signatures detected for each medium category into the relevant BN node (as explained in Section 3.9).

Sub-String Captured by Signatures	Association Strength to Category	
	Video: Movie	Video: TV
S10		2.95
WEB-DLRIP	0.15	0.7
<b>Total</b>	0.15	3.65

Table 84: Evidence Strength for Priko1isty.UNRATED.2009.HDRip.MP3.700MB.avi Torrent

Table 84 shows sub-strings captured by signatures and associated category strengths. Substring `WEB-DLRIP` refers to a video ripped from an online streaming

service. S10 denotes the 10<sup>th</sup> season in the series. Both these signatures are removable, so we filter them out of the file name. The cumulative strengths are entered as observations into the nodes “Video: Movie” Signature Found and “Video: TV” Signature Found respectively.

The remaining file name string is CSI.Miami and it does not correspond to any signature, therefore we suppose that it may be a part of a title. Using the method described in Section 4.4.3 we gain a single match to a title “CSI: Miami (2002)”, which is a TV series with a score of 1. We enter a hard observation “TV” into the node *Found in DB* (which is described Section 3.11).

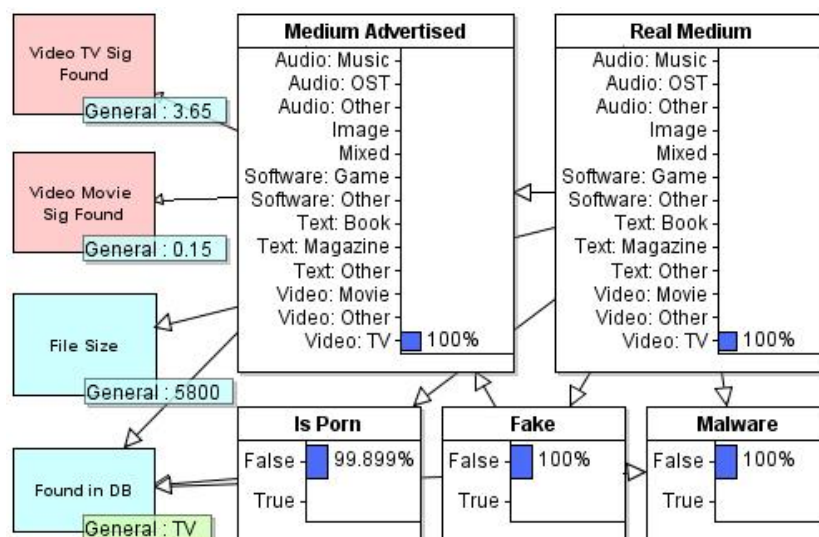

Figure 62: Complete Example for CSI.Miami.S10.WEB-DLRIP Torrent

Figure 62 illustrates the BN with observations entered and shows the result of evidence propagation through the model. Nodes with no new evidence are omitted. The combination of evidence suggests the item is almost certainly a TV series, not fake and not malware.

## 7.2. Research Objectives

Our main research hypothesis was that such an approach could provide improved accuracy over the current state-of-the-art systems such as that developed by MovieLabs – the organisation funded by the major Hollywood studios.

Throughout the project we defined and developed a framework that to build a Bayesian classification system that uses available domain knowledge and data. We explained our approach in detail such that it may be reproduced in the same or an alternative domain.

We performed extensive evaluation of our prototype system Toran, the MovieLabs benchmark system MVL and a panel of human classifiers in Chapter 6. While our smaller data sets only allow us to establish viability of our approach in medium and porn classification, the bigger BitSnoop sample definitively shows that Toran successfully rivals MVL, even in fully autonomous mode. There is also a potential for Toran to perform on par or better compared to humans when detecting fakes and malware. Based on these findings, we can claim that the research hypothesis has been established.

In addition the research hypothesis, the four research objectives from Section 1.2 were fulfilled as follows:

- **Research objective 1** is addressed in Chapter 3 by demonstrating how a BN model was constructed for classification and identification, and in Chapter 4 by explaining how evidence is extracted from file names to be used as observations in the model.
- **Research objective 2** is addressed in Sections 6.1 and 6.6 by showing that title matching improves classification results and allows automatically detecting fakes and malware on par or better than human experts.
- **Research objective 3** is addressed in Chapter 5 by creating a compatibility framework for results of different classification agents, and defining an extension to well-established error metrics that makes them compatible with a multi-label hierarchical class taxonomy.
- **Research objective 4** is addressed in Chapter 6 by providing assessment of the results in comparison between classifying agents on multiple data sets using a variety of metrics and evaluation techniques.

## 7.3. Future Work

This section considers two broad directions that can be pursued as a result of this research. One relates to improvements of the current implementation of our Toran prototype, and the other puts a focus on validation of classifier systems in this (or similar) application domains.

### 7.3.1. Improving Toran

We identify a number of potential extensions to the Toran prototype that may improve the classification results.

*Medium classification* may be improved by:

- Expanding the list of signatures associated with particular medium categories.
- More accurate and reliable way of modelling file size, for example, by fitting data from a sufficiently large sample to distribution functions or applying parameter learning techniques.
- More granularity could be added to the taxonomy by separating out new categories and introducing another level of hierarchy.

*Evidence detection* may be improved by applying a range of machine learning techniques to identify keywords or patterns and link them to categories, prior to refining them with expert knowledge.

The *BN model* may be expanded to include additional attributes, which are currently used as evidence but not attempted to be predicted, such as:

- format (e.g. HD, low resolution, theatre recording)
- content (e.g. animation, live action, anime, sport, news, documentary)
- country
- languages
- subtitles

*Torrent meta-data* may be exploited by obtaining and reading the torrent manifest and analysing download dynamics.

Additional *meta-data* may be obtained by performing search engine or large database queries, or attempting to search torrent trackers and obtain their classifications for torrents. It could be possible to look up a hash code of a torrent and try to extract any informative metadata found.

*Title, fake and malware identification* may be dramatically improved by:

- Improving the quality of the title database and exploring the possibility of including a small number of high impact titles.
- Adding translations into languages commonly found in torrents, such as Russian, Japanese, Korean and Chinese, including their English transliteration.
- Adding music, books, software and game titles and brands.

*Peers* is an indicator of how many clients are downloading or uploading the content of a torrent and could be used as an indicator of current popularity of the torrent. The rate at which the torrent's popularity falls or grows could reveal if the torrent is a *fake* or a legitimate item. A fake torrent is characteristic of a very short popularity span when it grows very fast in the beginning. However, as users finish downloading and realise it was a fake, they remove the torrent and its content from their machine, and its popularity starts falling rapidly. Unfortunately, this piece of evidence is not always available and requires monitoring to be exploited effectively.

A Bayesian approach may be used instead of sequence alignment to estimate *title match scores*.

More accurate classification of porn could be achieved by expanding the list of porn actresses and studios, as well as importing more porn movie titles and adding more porn-related signatures.

### 7.3.2. Further Contribution to Validation

One of the key problems with validation of a system like Toran is the lack of a sufficiently large data set of verified items. We believe that it may be beneficial to the research field if a large data set is established (including items of rare classes), verified and made available for other researchers. This would also contribute to research in machine learning by enabling training on verified data, as opposed to human processed data.

Another issue we noted in this thesis is the problem of evaluating predictions in a multi-label hierarchical set up. While the tiered scoring metric we proposed allows us, in principle, to address this issue, the topic may still need further research into the effects of prior distributions, used to interpret partial and “unknown” verdicts, on the usability of the tiered metric. For example, we use a scale of possible predictions to calibrate the tiered coefficient such that the metric scores these examples as expected. However, the desired ranking order of these example predictions is fundamental, as it impacts whether a metric is capable to be calibrated in such a way. It needs to be better established how a partial prediction relates to an “unknown” verdict, especially when the latter has a prior distribution strongly favouring a particular category. Depending on such a prior definition, an “unknown” verdict may attain a better score than a deliberate prediction.

## 7.4. Conclusions

This project attempted to devise a general methodology to approach a problem of classification in a setting where popular machine learning or frequentist approaches may not be appropriate. The resulting framework draws on a number of techniques borrowed from various research areas, such as Bayesian networks, classification and sequence alignment.

The domain we chose to demonstrate the application of methodology in practice may not be the obvious one. Some could argue that a classifier could just be trained on a set of human-processed items without the need to create an expert knowledge system. In our study we found out that even a panel of three trained human experts is far from ideal when it comes to classifying items like torrent files, and one must keep in mind that these human classifiers also had the power of Internet search engines at their hands. This important finding means that a system trained to perform like humans will make the same mistakes as humans. Unfortunately, it is very expensive to establish a sufficiently large sample of verified items. It took us several weeks and many man-hours to capture and verify a small sample of just 120 items. Downloading multiple torrents for verification from an established torrent tracker is not a big problem, but it is quite a challenge to do the same for a bunch of torrents not indexed by any established tracker with a lot of sharing users.

We do believe, however, that it would be highly beneficial to capture a larger sample of verified items, to allow for strong conclusions when testing a classifier system. One of the drawbacks of a small sample is that margin of error is quite large and may be an issue when two classifiers need to be compared and both seem to perform on a somewhat similar level.

We are happy, however, that several samples created as part of this project will now be available to other researchers, including those who are seeking to improve



classification methods or those who may want to study reasons for worse than expected human performance.

Through our existing contacts and the sophistication of the Toran system developed we hope that the methodology finds its way into a widely available implementation that may help the public by adding transparency to estimating composition of content downloaded around the world. This would help address the issue of regularly overestimated financial losses due to privacy.

We are also confident that the general framework described in the thesis will allow other researchers to develop classification systems in applicable domains. We highlight three such application domains already being considered for this work:

1. A new project that is focused on attribution of artworks and can reuse much of the framework presented in the thesis (except for string processing). The BN model is strongly related to the one we described in Chapter 3 and various analyses of imagery are easily incorporated into the concept of evidence associated with nodes in the BN.
2. A system that analyses a user's query to an online retailer and figures out the desired shopping category; and a closely related system that classifies generic online shop item pages into a particular taxonomy. The latter may be especially relevant for services that aim to aggregate online shopping experience from different retailers.
3. A very different example, proposed by a colleague who works in cyber security, was that this framework may be helpful in creating a system that classifies and monitors risk of sensitive data leaving corporate premises.

The range of components involved in the final system produced by our suggested framework means that, depending on the application domain, some components may be more relevant than others. For example, Toran uses signature associations to filter the torrent name and then sequence alignment to match titles, and the

evidence produced by this process is useful but not critical to the classification system, so in its current state it has a lot of unrealised potential. For a different application, such as the above cyber security example, sequence alignment may be used to detect parts of sensitive data obfuscated by surrounding noise. For such a system, evidence signatures may be of lesser importance compared to an efficient and effective sequence alignment component, so it may be sensible to concentrate on refining it at the cost of underused signature definitions.

It may be possible to extend the BN we made to predict many other features, such as video/image quality, languages, genres etc. It would then be viable to apply the methodology to developing a real-time recommender system that could take into account items the user downloaded in the past, and highlighting suggested items on the webpages the user visits.

We believe that the project was a success in the sense that we defined a general framework and demonstrated how, following its steps, we create a sensible classification system that is capable of rivalling contemporary industrial applications.

# Appendices

## Appendix A XML Data Structure

The XML schema is available as part 'Appendix A – Report Schema.xsd' of the illustrative materials attached to this thesis. Alternatively, it is available online (Dementiev 2015).

```
<torrent hash="6004b255e164d81a8b3b98990301b758d2f0fe1f">
  <attributes>
    <size>700</size>
    <name>Entrapment.mkv</name>
  </attributes>
  <observations>
    <signature value="mkv">
      <association name="Video: Movie" value="0.55"/>
      <association name="Video: TV" value="0.6"/>
    </signature>
    <associations_summary>
      <association name="Video: Movie" value="0.55"/>
      <association name="Video: TV" value="0.6"/>
    </associations_summary>
    <title score="0.95" year="2009" name="Entrapment" category="Video: Movie" risky="0" porn="1"/>
  </observations>
  <attributes_derived>
    <name_filtered>ENTRAPMENT</name_filtered>
  </attributes_derived>
  <predictions>
    <porn>0.684000</porn>
    <fake>0.000000</fake>
    <malware>0.000000</malware>
    <medium_full>
      <label name="Audio: Music" value="1.8508898210711777E-4"/>
      <label name="Audio: OST" value="2.839702574419789E-6"/>
      <label name="Audio: Other" value="9.687494184618117E-7"/>
      <label name="Image" value="3.4726501780824037E-6"/>
      <label name="Mixed" value="2.337589876333368E-6"/>
      <label name="Software: Game" value="8.069046998571139E-6"/>
      <label name="Software: Other" value="2.234982639492955E-5"/>
      <label name="Text: Book" value="1.4067740039536147E-6"/>
      <label name="Text: Magazine" value="2.003991312449216E-6"/>
      <label name="Text: Other" value="1.0480264656109739E-8"/>
      <label name="Video: Movie" value="0.9973332285881042"/>
      <label name="Video: Other" value="4.506212717387825E-4"/>
      <label name="Video: TV" value="0.0019875874277204275"/>
    </medium_full>
  </predictions>
</torrent>
```

Figure A.1: Processed Torrent XML Record Example #1

```

<torrent hash="60029033ab7dafb7aed1fbf1593e929d63107bd7">
  <attributes>
    <size>617</size>
    <name>How.I.Met.Your.Mother.S04E20.rus.eng.HDTV.720p.[Kuraj-Bambey.Ru].mkv</name>
  </attributes>
  <observations>
    <signature value="S04E20">
      <association name="Video: TV" value="2.95"/>
    </signature>
    <signature value="mkv">
      <association name="Video: Movie" value="0.55"/>
      <association name="Video: TV" value="0.6"/>
    </signature>
    <signature value="eng">
      <association name="Language" value="0.75"/>
    </signature>
    <signature value="rus">
      <association name="Language" value="0.75"/>
    </signature>
    <signature value="720p">
      <association name="Video: Movie" value="0.55"/>
      <association name="Video: Other" value="0.5"/>
      <association name="Video: TV" value="0.95"/>
    </signature>
    <signature value="HDTV">
      <association name="Video: Movie" value="0.2"/>
      <association name="Video: TV" value="1.05"/>
    </signature>
    <associations_summary>
      <association name="Language" value="1.5"/>
      <association name="Video: Movie" value="1.3"/>
      <association name="Video: TV" value="5.55"/>
      <association name="Video: Other" value="0.5"/>
    </associations_summary>
    <title score="1.0" year="2005" name="How I Met Your Mother" category="Video: TV" risky="0" porn="0"/>
  </observations>
  <attributes_derived>
    <name_filtered>HOW I MET YOUR MOTHER</name_filtered>
  </attributes_derived>
  <predictions>
    <porn>0.001100</porn>
    <fake>0.000000</fake>
    <malware>0.000000</malware>
    <medium_full>
      <label name="Audio: Music" value="2.2832037649411774E-10"/>
      <label name="Audio: OST" value="6.505318853045061E-12"/>
      <label name="Audio: Other" value="2.2192536437010135E-12"/>
      <label name="Image" value="8.00113274246339E-12"/>
      <label name="Mixed" value="5.299763752852904E-11"/>
      <label name="Software: Game" value="1.8332355078420903E-10"/>
      <label name="Software: Other" value="1.1576479863606437E-7"/>
      <label name="Text: Book" value="3.2573115212042314E-12"/>
      <label name="Text: Magazine" value="4.5932949284399616E-12"/>
      <label name="Text: Other" value="2.4008649140484263E-14"/>
      <label name="Video: Movie" value="2.3076798242982477E-4"/>
      <label name="Video: Other" value="2.5574213395884726E-6"/>
      <label name="Video: TV" value="0.9997665286064148"/>
    </medium_full>
  </predictions>
</torrent>

```

Figure A.2: Processed Torrent XML Record Example #2

```

<torrent hash="d7eee31291dbf956b4821b1652185d5faa84c869">
  <attributes>
    <size>2232</size>
    <name>X-Men Days of Future Past 2014 720p WEB-Rip x264 AAC - KiNGDOM [S@BBIR].mp4</name>
  </attributes>
  <observations>
    <signature value="2014">
      <association name="Year" value="1.0"/>
    </signature>
    <signature value="AAC">
      <association name="Video: Movie" value="0.35"/>
      <association name="Video: TV" value="0.85"/>
    </signature>
    <signature value="mp4">
      <association name="Video: Movie" value="1.15"/>
      <association name="Video: Other" value="1.5"/>
      <association name="Video: TV" value="1.2"/>
    </signature>
    <signature value="x264">
      <association name="Video: Movie" value="0.6"/>
      <association name="Video: TV" value="0.4"/>
    </signature>
    <signature value="720p">
      <association name="Video: Movie" value="0.55"/>
      <association name="Video: Other" value="0.5"/>
      <association name="Video: TV" value="0.95"/>
    </signature>
    <signature value="@">
      <association name="Porn" value="0.55"/>
    </signature>
    <signature value="Rip">
      <association name="Video: Movie" value="0.65"/>
      <association name="Video: Other" value="0.3"/>
      <association name="Software: Game" value="0.1"/>
      <association name="Video: TV" value="0.35"/>
    </signature>
    <associations_summary>
      <association name="Porn" value="0.55"/>
      <association name="Video: Movie" value="3.3000000000000003"/>
      <association name="Video: TV" value="3.7499999999999996"/>
      <association name="Video: Other" value="2.3"/>
      <association name="Software: Game" value="0.1"/>
    </associations_summary>
    <title score="1.0" year="2014" name="X-Men: Days of Future Past" category="Video: Movie" risky="0"
    porn="0"/>
  </observations>
  <attributes_derived>
    <name_filtered>X MEN DAYS OF FUTURE PAST 2014 WEB</name_filtered>
  </attributes_derived>
  <predictions>
    <porn>0.021600</porn>
    <fake>0.000100</fake>
    <malware>0.000000</malware>
    <medium_full>
      <label name="Audio: Music" value="5.594980923007142E-9"/>
      <label name="Audio: OST" value="2.1110850914607404E-11"/>
      <label name="Audio: Other" value="1.9538912588573654E-12"/>
      <label name="Image" value="4.5650245736328365E-12"/>
      <label name="Mixed" value="1.1459589943640935E-9"/>
      <label name="Software: Game" value="3.1275863676683E-8"/>
      <label name="Software: Other" value="1.989615384445642E-6"/>
      <label name="Text: Book" value="1.3232828027787136E-11"/>
      <label name="Text: Magazine" value="4.420629660939479E-12"/>
      <label name="Text: Other" value="1.3504762629359957E-13"/>
      <label name="Video: Movie" value="0.9994342923164368"/>
      <label name="Video: Other" value="3.533016424626112E-4"/>
      <label name="Video: TV" value="2.1038689010310918E-4"/>
    </medium_full>
  </predictions>
</torrent>

```

Figure A.3: Processed Torrent XML Record Example #3

## Appendix B Results in XML Format

Note that the results in XML format are available as part 'Appendix B – Results.xml' of the illustrative materials attached to this thesis. Alternatively, they are available online (Dementiev 2015).

## Appendix C Databases of Titles, Actors and Studios

Note that the following databases are available, including column headers, in tab-separated value format as part of the illustrative materials attached to this thesis. Alternatively, they are available online (Dementiev 2015).

### C.1. Titles Database

This data set is available as illustrative material 'Appendix C.1 - Titles Database.tsv'.

### C.2. Porn Actor Database

This data set is available as illustrative material 'Appendix C.2 - Porn Actor Database.tsv'.

### C.3. Porn Studio Database

This data set is available as illustrative material 'Appendix C.3 - Porn Studio Database.tsv'.

## Appendix D Data Sets

Note that the following data sets are available, including column headers, in tab-separated value format as part of the illustrative materials attached to this thesis. Alternatively, they are available online (Dementiev 2015).

### D.1. DS2500

This data set is available as illustrative material 'Appendix D.1 - DS2500.tsv'.

### D.2. DS480

This data set is available as illustrative material 'Appendix D.2 - DS480.tsv'.

### D.3. DS120

This data set is available as illustrative material 'Appendix D.3 - DS120.tsv'.

### D.4. Fakes and Malware Data Set

This data set is available as illustrative material 'Appendix D.4 - Fakes and Malware Data Set.tsv'.

### D.5. BitSnoop Data Set

This data set is available as illustrative material 'Appendix D.5 – BitSnoop Data Set.tsv'.

## Appendix E Junction Tree BN Propagation Algorithm

The major steps of the algorithm are:

- 1) *Moralise* the BN into an undirected graph by adding an edge between every pair of nodes, which have a common child, and removing directions from edges.

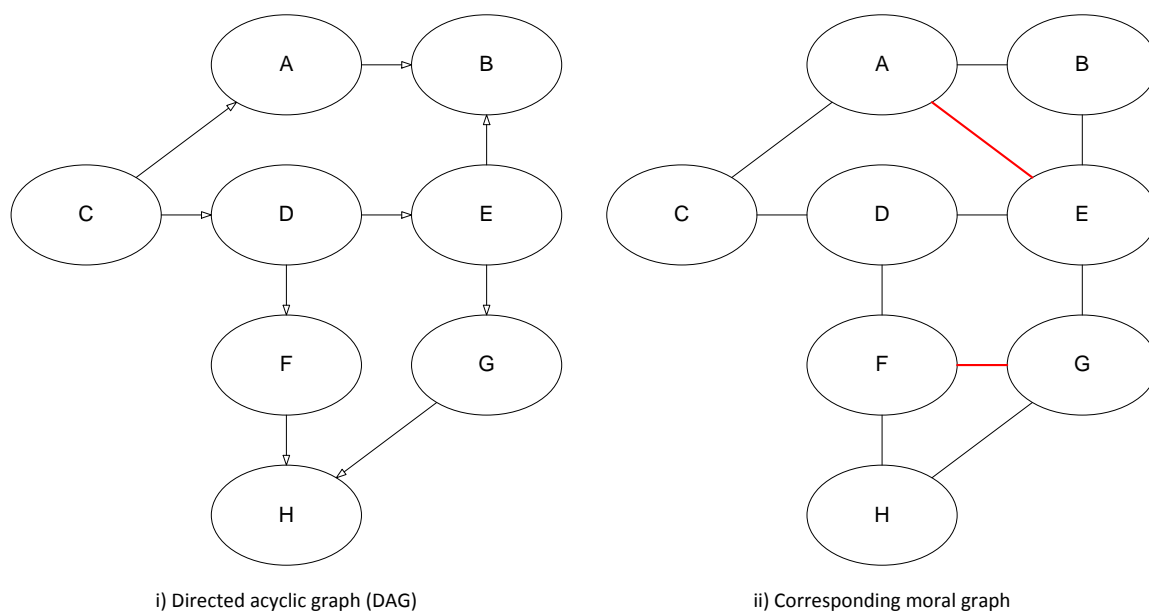

Figure E.1: Example of Graph Moralisation

Figure E.1 (i) shows an example Bayesian network. Nodes A and E have a common child B, and nodes F and G have a common child H. To moralise the graph, these 2 pairs of nodes are connected with an edge, and are then called 'married'. Figure E.1 (ii) shows the new edges in red, and also demonstrates how edge direction was removed.

- 2) *Triangulate* the moral graph to identify *clusters*. To do this, the following procedure should be repeated:

- a) Calculate *weight* for every node. The weight is equal to the number of edges that have to be added, such that the node forms a complete *sub-graph* in any combination with a pair of its neighbours.

- b) Pick the node that has the minimal weight, and add all the edges required.

When the DAG is a BN, we use the product of the number of states in the node



and its neighbours as the secondary weight, which is required when there are multiple nodes with the same minimum weight. For our example we assume all nodes have an equal number of states, hence any minimum-weight node is acceptable.

- c) Record the node and its neighbours as a cluster.
- d) Remove the node from the graph.

It is important to note that this step is not deterministic and there could be multiple junction trees created from the same DAG. For this example, the following procedure is used to create one of the possible sets of clusters:

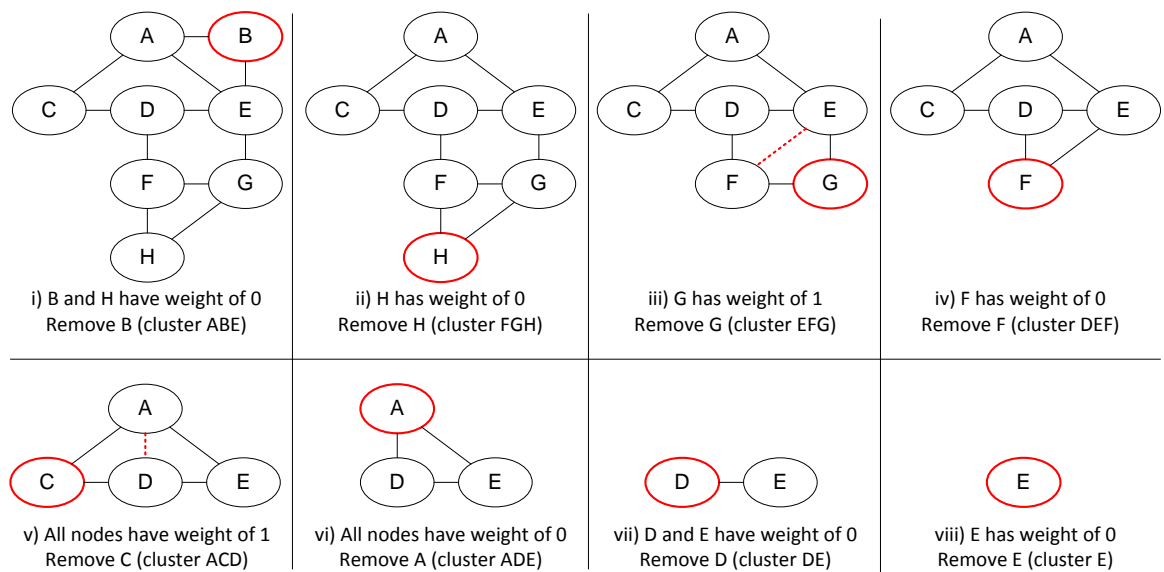

Figure E.2: Graph Triangulation Example

Figure E.2 demonstrates how we identified clusters ABE, FGH, EFG, DEF, ACD, ADE, DE and E.

- 3) Construct the *junction tree* from the clusters, identified earlier by following the process:
  - a) Discard any clusters, which are contained in another cluster (e.g. DE and E).
  - b) Identify  $n - 1$  separators between the remaining  $n$  clusters such. A separator is a common subset between a pair of clusters.
  - c) Build the junction tree by connecting clusters via separators, selecting first the biggest separators, then the ones with minimum weight, which is the product

of all states in all nodes within the separator. In our example, all separators are 2 nodes big and all nodes have the same number of states, so the order is not important.

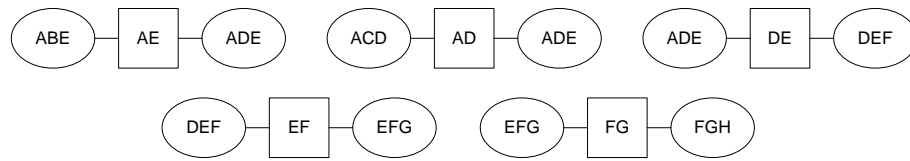

Figure E.3: Clusters and Separators

Note that the Figure E.3 identified that ADE is linked to 3 separators, so it will be a junction in the tree:

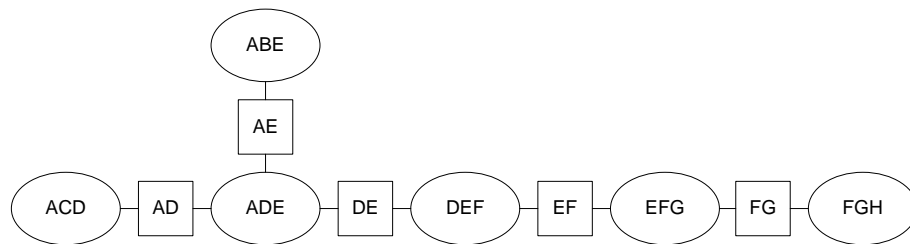

Figure E.4: Junction Tree Example

Figure E.4 presents the final junction tree for a BN from Figure E.1 (i). AgenaRisk uses the *sum-product* algorithm proposed in (Pearl 1982) for evidence propagation, which employs the idea of message passing. The abstract sequence is:

- a) Designate one cluster node as *root*. Each node that has only 1 connection is called a *leaf*.
- b) Evidence is *collected*, starting from the leaf nodes, toward the root node.
- c) Once the evidence from the whole tree is gathered at the root node, it is then *distributed* in the opposite direction until all leaf nodes receive an update. As a result, all nodes in the BN are updated to the exact *marginal* probabilities. See Figure E.5 for illustration of this sequence.

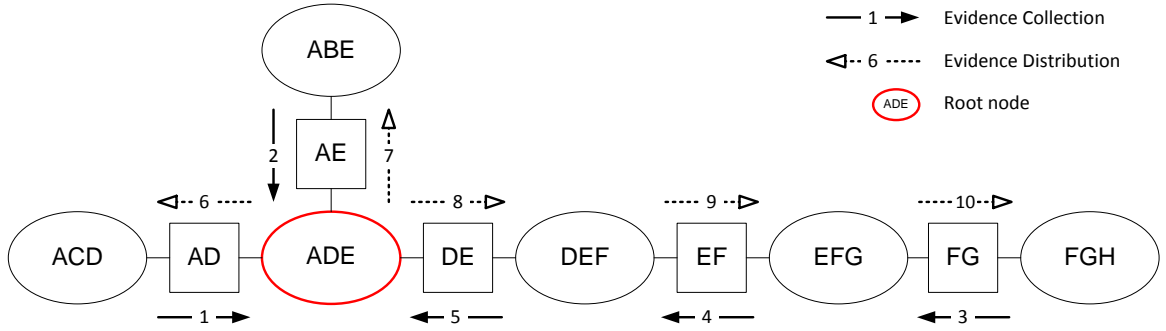

Figure E.5: Illustration of Evidence Collection and Distribution Sequence

Messages being passed along the graph are updated with new evidence at every node they pass through, and a message cannot be sent until all prerequisites were received. For the purpose of this algorithm, the junction tree above is a factor graph (Kschischang et al. 2001). Generally, a message passed from a variable  $x$  to a factor  $y$  is denoted as a function  $\mu_{x \rightarrow y}$ , and is defined as a product of messages from all *other* factor nodes to this variable:

$$\forall S_i \in x: \mu_{x \rightarrow y}(S_i) = \prod_{y' \in N(x) \setminus y} \mu_{y' \rightarrow x}(S_i) \quad (50)$$

Where  $S_i$  is a particular state of the variable  $x$  and  $N(x)$  is a set of all factor nodes neighbouring  $x$ . In leaf nodes the message is initialised as marginal distributions.

The algorithm recognises the type of message passed from a factor  $y$  to a variable  $x$  separately, and it is denoted as a function  $\mu_{y \rightarrow x}$  and is defined as a product of all messages accumulated by the factor, marginalised over all *other* variables in the graph:

$$\forall S_i \in x: \mu_{y \rightarrow x}(S_i) = \sum_{x'' \in X \setminus x} f(x'') \prod_{x' \in N(y) \setminus x} \mu_{x' \rightarrow y}(S_i) \quad (51)$$

Where  $S_i$  is a particular state of the variable  $x$ ,  $X$  is the set of all variables in the graph  $f(x'')$  is the marginal distribution of variable  $x''$  and  $N(y)$  is a set of all variable nodes neighbouring  $y$ .

The sum-product algorithm is best suited to computing exact marginal distributions on DAGs, but can also be approximated for general graphs (Pearl 1988).

## Appendix F BN Definition

The Toran's underlying classification model is available as illustrative material 'Appendix A - Toran.cmp' attached to this thesis, or online (Dementiev 2015). It can be viewed and run with the free AgenaRisk software (Agena 2016b). Tables and figures below are related to the NPT definition of the *File Size* node.

> MB	Audio: Music	Audio: OST	Audio: Other	Image	Software: Game	Software: Other	Text: Book	Text: Magazine	Text: Other	Video: Movie	Video: TV	Video: Other
10	15	3	0	12	4	78	47	1	4	0	0	6
20	3	0	2	13	3	22	12	6	0	0	0	6
30	8	0	2	3	1	7	4	4	0	0	0	5
40	7	0	1	4	2	7	5	0	0	0	0	4
50	7	1	2	5	0	6	0	5	0	1	1	7
60	7	1	3	6	2	4	1	1	0	0	0	10
70	13	2	3	4	2	5	2	1	0	0	2	4
80	14	2	0	1	1	2	0	2	0	1	1	7
90	18	1	2	1	0	0	0	4	0	0	2	3
100	11	0	2	2	1	3	2	4	0	0	4	2
200	75	3	8	15	6	11	2	1	0	1	50	43
300	38	0	4	4	11	7	1	0	0	0	43	24
400	30	2	0	1	4	7	0	0	0	12	77	24
500	17	0	2	2	2	4	0	0	0	5	21	25
600	8	0	1	1	2	6	1	1	0	8	27	17
700	6	0	2	1	5	3	1	0	0	71	11	19
800	5	0	1	2	3	0	0	0	0	128	25	34
900	4	0	0	2	1	1	0	0	0	13	8	13
1000	3	0	0	0	3	2	1	0	0	11	4	15
2000	14	1	2	2	15	5	1	0	0	155	45	72
3000	4	0	1	2	5	4	0	0	0	41	13	21
4000	4	0	0	0	7	4	1	0	1	12	11	13
5000	2	0	0	0	7	4	1	2	0	31	11	7
6000	1	0	0	0	2	0	0	0	0	6	12	6
7000	0	0	0	0	3	3	0	0	0	8	5	6
8000	2	0	0	0	3	1	1	0	0	8	4	3
9000	0	0	0	0	1	0	0	0	0	6	5	1
10000	0	0	0	1	0	0	0	0	0	2	5	1
20000	4	0	0	0	6	0	0	0	0	2	15	3
30000	0	0	0	0	1	2	0	0	0	5	2	0
40000	1	0	0	0	0	0	0	0	0	0	5	1
50000	0	0	0	0	0	0	0	0	0	1	1	0

Table F.1: File Size Distribution in Medium Categories by Experts on 2500 Sample

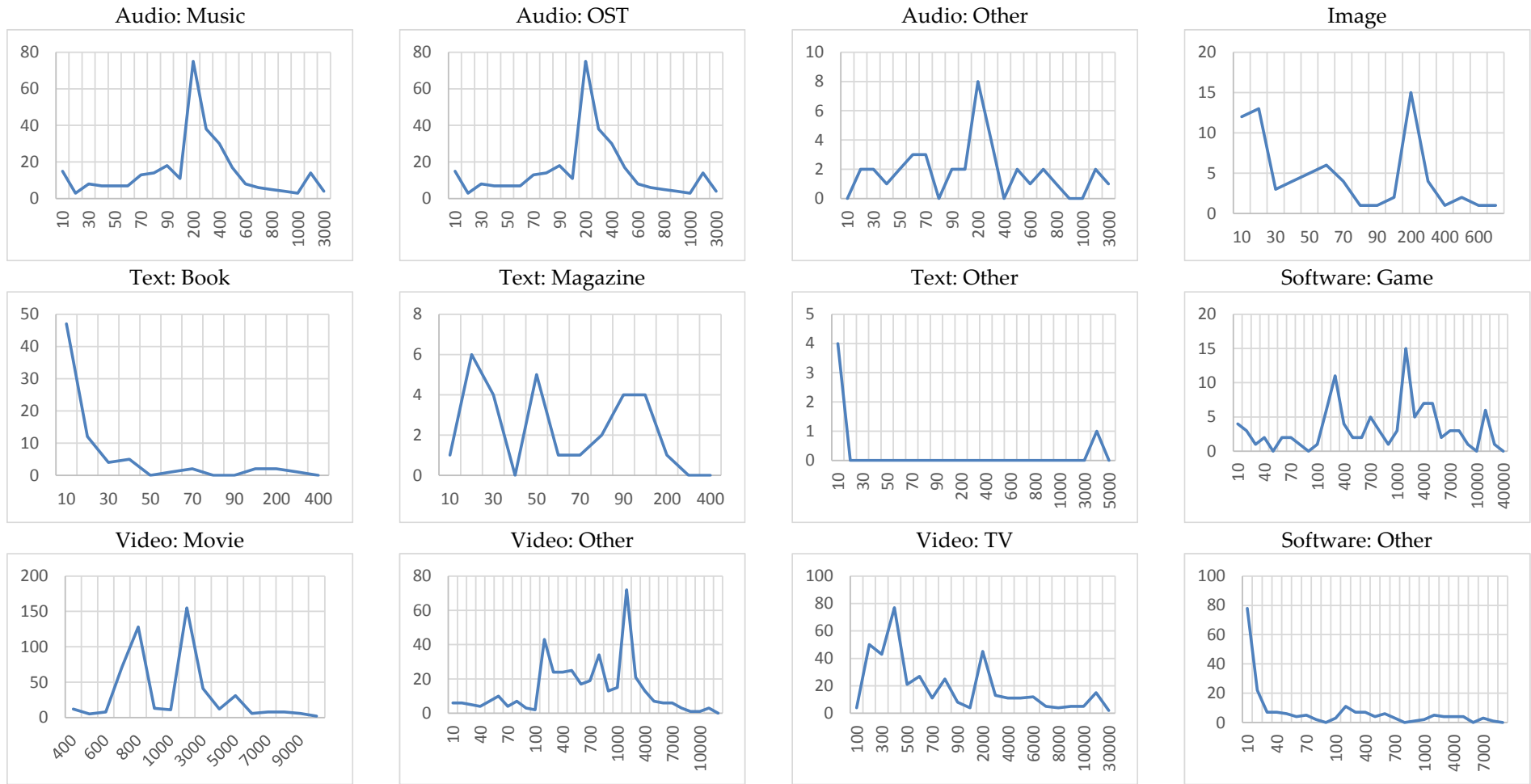

Figure F.1: File Size Distribution in Medium Categories by Experts on 2500 Sample

MB	Audio: Music	Audio: OST	Audio: Other	Image	Mixed	Software: Game	Software: Other	Text: Book	Text: Magazine	Text: Other	Video: Movie	Video: Other	Video: TV
0 - 10	2.23E-02	5.86E-02	7.93E-02	1.42E-01	3.35E-05	2.35E-02	1.77E-01	3.28E-01	2.79E-02	3.60E-01	3.91E-10	1.62E-09	7.34E-10
10 - 20	2.53E-02	6.15E-02	8.01E-02	1.13E-01	8.82E-05	1.64E-02	1.45E-01	2.21E-01	4.19E-02	2.30E-01	1.95E-09	2.11E-03	6.32E-04
20 - 30	2.98E-02	6.46E-02	8.09E-02	9.43E-02	2.18E-04	1.15E-02	1.19E-01	1.48E-01	5.58E-02	1.48E-01	9.77E-09	3.51E-03	1.05E-03
30 - 40	3.42E-02	6.79E-02	8.17E-02	7.55E-02	5.07E-04	4.06E-03	9.75E-02	9.98E-02	6.98E-02	9.43E-02	4.88E-08	5.85E-03	1.76E-03
40 - 50	4.02E-02	7.13E-02	8.26E-02	6.60E-02	1.11E-03	5.80E-03	8.00E-02	6.71E-02	8.20E-02	6.04E-02	2.44E-07	9.75E-03	2.93E-03
50 - 60	4.76E-02	7.48E-02	8.34E-02	6.13E-02	2.27E-03	8.29E-03	6.56E-02	4.51E-02	8.12E-02	3.87E-02	1.22E-06	1.63E-02	4.88E-03
60 - 70	5.65E-02	7.85E-02	8.42E-02	6.13E-02	4.38E-03	1.18E-02	5.38E-02	3.03E-02	8.12E-02	2.48E-02	6.10E-06	2.71E-02	8.13E-03
70 - 80	6.70E-02	8.20E-02	8.51E-02	6.60E-02	7.94E-03	1.69E-02	4.41E-02	2.04E-02	8.12E-02	1.58E-02	3.05E-05	4.51E-02	1.36E-02
80 - 90	8.48E-02	8.61E-02	8.60E-02	7.08E-02	1.35E-02	2.42E-02	3.62E-02	1.37E-02	8.04E-02	1.01E-02	1.53E-04	7.52E-02	2.26E-02
90 - 100	1.12E-01	9.23E-02	8.68E-02	8.02E-02	2.16E-02	3.45E-02	2.97E-02	9.19E-03	7.95E-02	6.48E-03	7.63E-04	1.25E-01	3.76E-02
100 - 200	1.18E-01	9.48E-02	8.57E-02	8.49E-02	3.24E-02	4.93E-02	2.43E-02	6.17E-03	7.91E-02	4.17E-03	3.82E-03	9.24E-02	6.27E-02
200 - 300	1.12E-01	6.07E-02	4.28E-02	4.25E-02	4.57E-02	7.05E-02	2.07E-02	3.94E-03	7.85E-02	2.66E-03	9.54E-03	7.92E-02	1.05E-01
300 - 400	6.70E-02	3.88E-02	2.10E-02	2.12E-02	6.05E-02	5.48E-02	1.76E-02	2.56E-03	7.79E-02	1.73E-03	2.38E-02	5.28E-02	1.17E-01
400 - 500	4.91E-02	2.48E-02	1.03E-02	1.06E-02	7.53E-02	3.91E-02	1.49E-02	1.64E-03	4.19E-02	1.08E-03	4.77E-02	3.96E-02	1.05E-01
500 - 600	3.72E-02	1.58E-02	5.04E-03	5.31E-03	8.80E-02	1.96E-02	1.27E-02	1.05E-03	2.09E-02	7.20E-04	9.54E-02	2.97E-02	5.97E-02
600 - 700	2.68E-02	1.02E-02	2.49E-03	2.65E-03	9.67E-02	1.57E-02	1.08E-02	6.56E-04	1.05E-02	4.32E-04	9.94E-02	2.97E-02	2.24E-02
700 - 800	1.93E-02	6.44E-03	1.25E-03	1.33E-03	9.97E-02	1.96E-02	9.18E-03	3.94E-04	5.23E-03	2.88E-04	9.54E-02	3.96E-02	1.49E-02
800 - 900	1.49E-02	4.10E-03	5.97E-04	6.63E-04	9.67E-02	2.74E-02	7.81E-03	2.63E-04	2.62E-03	2.16E-04	5.56E-02	8.25E-02	2.24E-02
900 - 1k	1.04E-02	2.54E-03	2.71E-04	3.32E-04	8.80E-02	6.26E-02	6.63E-03	1.97E-04	1.31E-03	1.44E-04	4.77E-02	1.22E-01	5.53E-02
1k - 2k	7.44E-03	1.56E-03	1.36E-04	1.66E-04	7.53E-02	9.40E-02	5.64E-03	1.12E-04	6.54E-04	7.20E-05	5.56E-02	6.10E-02	6.12E-02
2k - 3k	5.21E-03	9.76E-04	6.51E-05	8.29E-05	6.05E-02	7.05E-02	4.78E-03	7.22E-05	3.27E-04	7.20E-05	1.19E-01	3.05E-02	5.53E-02
3k - 4k	3.87E-03	6.25E-04	3.25E-05	4.15E-05	4.57E-02	5.48E-02	4.07E-03	4.59E-05	1.63E-04	7.20E-06	1.27E-01	1.53E-02	4.97E-02
4k - 5k	2.83E-03	4.10E-04	1.63E-05	2.07E-05	3.24E-02	3.91E-02	3.45E-03	2.95E-05	8.17E-05	7.20E-06	1.19E-01	7.63E-03	3.88E-02
5k - 6k	2.08E-03	2.54E-04	7.59E-06	1.04E-05	2.16E-02	3.13E-02	2.94E-03	1.84E-05	4.09E-05	7.20E-06	5.96E-02	3.82E-03	3.11E-02
6k - 7k	1.49E-03	1.56E-04	5.42E-06	5.18E-06	1.35E-02	2.82E-02	2.50E-03	1.18E-05	2.04E-05	7.20E-06	2.38E-02	1.91E-03	2.49E-02
7k - 8k	1.12E-03	9.76E-05	5.42E-06	2.59E-06	7.94E-03	2.54E-02	2.13E-03	6.56E-06	1.02E-05	7.20E-06	9.54E-03	9.54E-04	1.99E-02
8k - 9k	7.44E-04	5.86E-05	5.42E-06	1.30E-06	4.38E-03	2.28E-02	1.06E-03	4.59E-06	5.11E-06	7.20E-06	3.82E-03	4.77E-04	1.59E-02
9k - 10k	5.21E-04	1.95E-05	5.42E-06	6.48E-07	2.27E-03	3.13E-02	5.31E-04	2.63E-06	2.55E-06	7.20E-06	1.53E-03	2.38E-04	1.27E-02
10k - 20k	3.87E-04	1.95E-05	5.42E-06	3.24E-07	1.11E-03	3.91E-02	2.65E-04	1.97E-06	1.28E-06	7.20E-06	6.10E-04	1.19E-04	1.02E-02
20k - 30k	2.83E-04	1.95E-05	5.42E-06	1.62E-07	5.07E-04	2.35E-02	1.33E-04	6.56E-07	6.39E-07	7.20E-06	2.44E-04	5.96E-05	8.14E-03
30k - 40k	2.08E-04	1.95E-05	5.42E-06	8.10E-08	2.18E-04	1.57E-02	6.63E-05	6.56E-07	3.19E-07	7.20E-06	9.77E-05	2.98E-05	6.52E-03
40k - 50k	1.49E-04	1.95E-05	5.42E-06	4.05E-08	8.82E-05	7.83E-03	3.32E-05	6.56E-07	1.60E-07	7.20E-06	3.91E-05	1.49E-05	5.21E-03
50k+	1.49E-04	1.95E-05	5.42E-06	2.02E-08	3.35E-05	7.83E-04	3.32E-05	6.56E-07	7.98E-08	7.20E-06	1.56E-05	7.45E-06	4.17E-03

Table F.2: NPT for *File Size* in Current Model

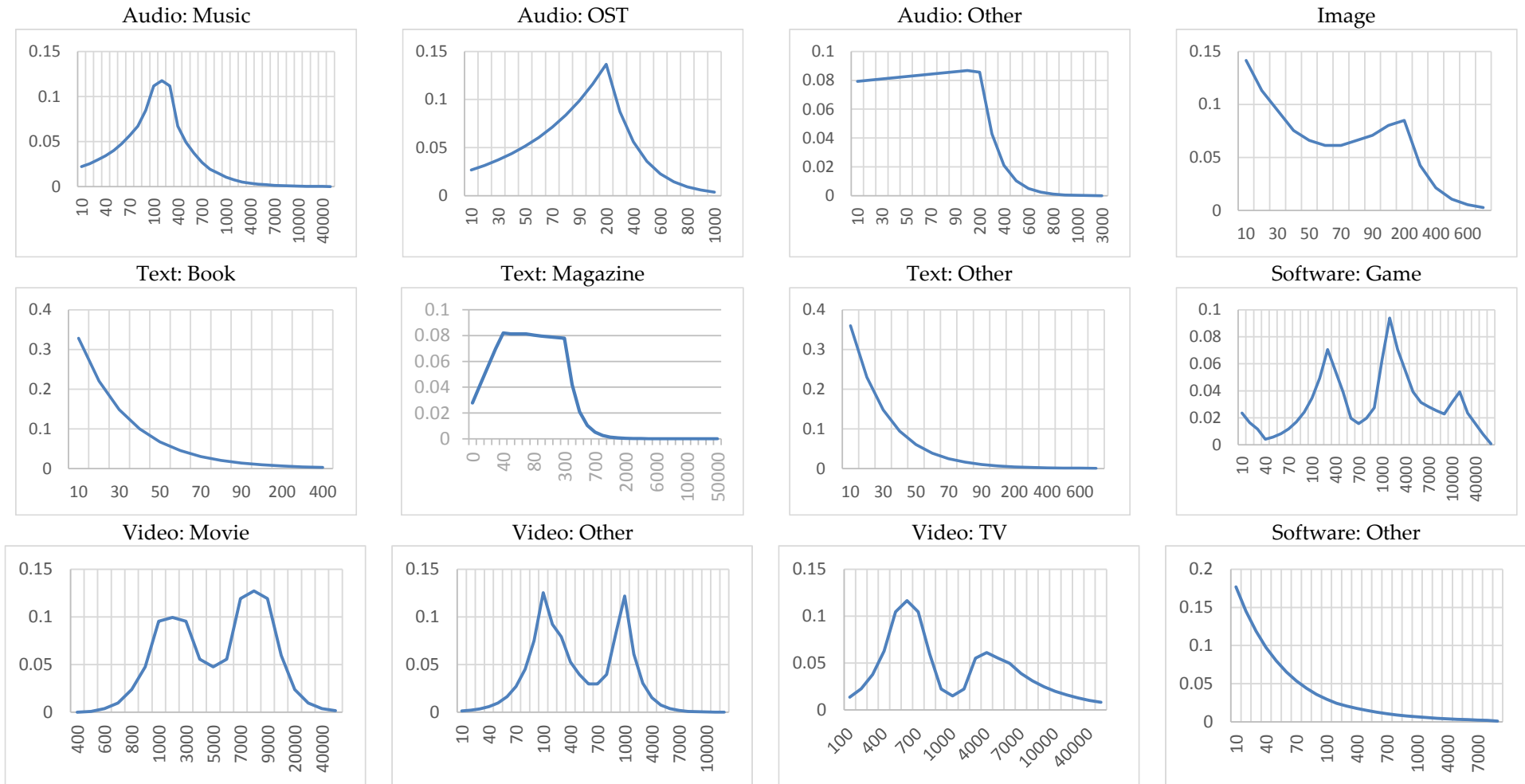

Figure F.2: File Size NPT Plots in Current Model

## Appendix G Example Model Output for Different Signature Combinations

Note that only the relevant fragment from the example is displayed. All other nodes which are supposed to have an observation entered can be assumed instantiated to “none”, “0”, “false” etc. as applicable.

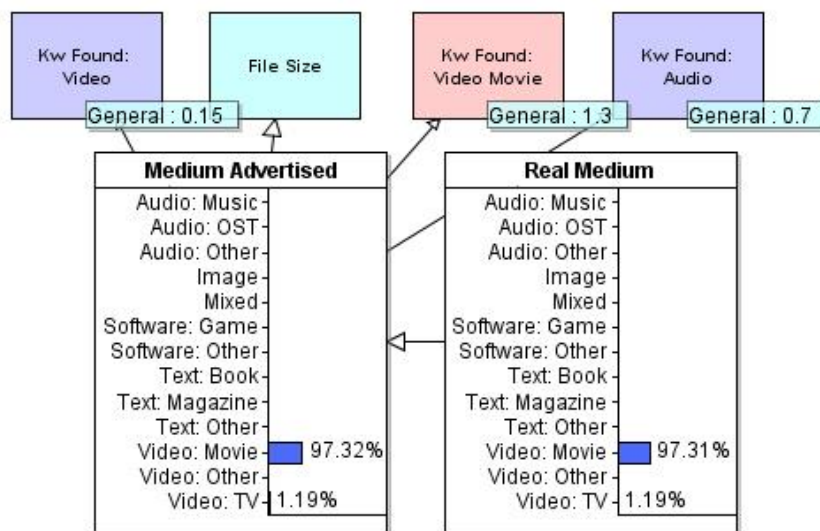

Figure G.1: Example – Movie (Audio and Video Signatures)

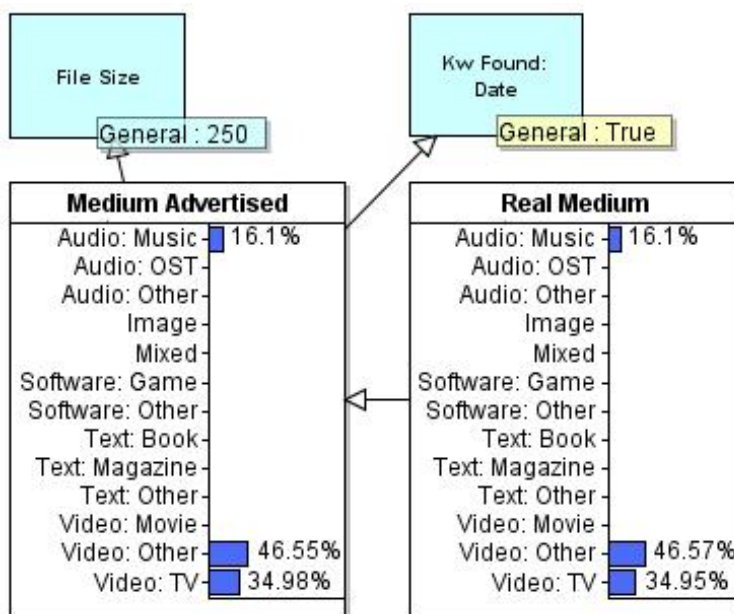

Figure G.2: Example – Television or Radio Recording (Size and Date)



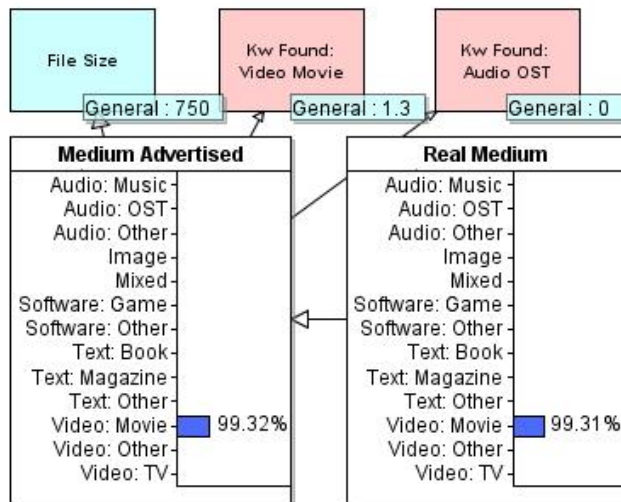

Figure G.3: Example – Movie and No OST Signatures

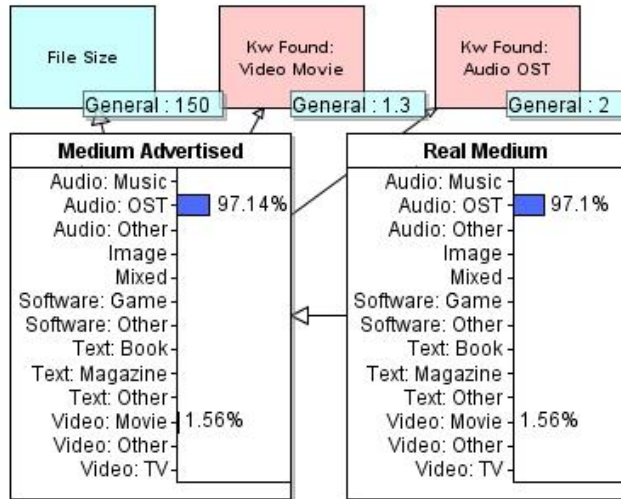

Figure G.4: Example – Movie and OST Signatures, with File Size

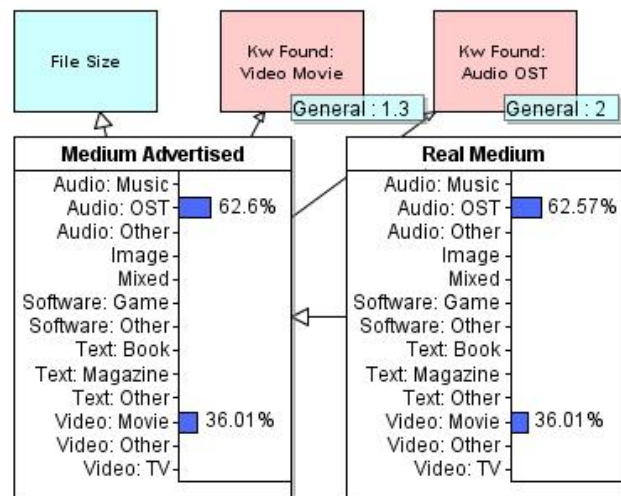

Figure G.5: Example – Movie and OST Signatures, but No File Size

## Appendix H Signature and Keyword Configurations

Note that the following configurations are available, including column headers, in tab-separated value format as part of the illustrative materials attached to this thesis. Alternatively, they are available online (Dementiev 2015).

### H.1. MovieLabs Keyword Configuration

This data set is available as illustrative material 'Appendix H.1 - MovieLabs Keyword Configuration.tsv'.

### H.2. Toran Signature Configuration

This data set is available as illustrative material 'Appendix H.2 - Toran Signature Configuration.tsv'.

## Appendix I Pattern Parts of the TV Signature

Part	Options
1	(?! (19 20) [0-9]{2}) [0-9]+(-[0-9]+)? full all [а-я]+[йе] все весь whole complet(e a)?
2	saisons? sasong season[se]? seizoe?n cezon[iy]? seri[ae]s?(?!1) seri(ia ja ya i j y) se[sz]on[iy]? сезоны? episodes? сери[яий] v[yu]p[uy]sk(i ov)? temp(orad(a es))? bölüm 시즌 화 chapters? част [ьи] [эе]п[ии]зод([ьи] ов)? выпуски?
3	iz из from
4	(?! (19 20) [0-9]{2}) [0-9]+(-[0-9]+)? one two three four five (I{1,3} IV V VI{1,3} IX X)

Table I.1: Complex TV Pattern Parts

## Appendix J Torrent Name Filtering Examples

Original Name	Filtered Name
Shutter Island [2010 leaked screening]DvDrip -wmv [new movie]	SHUTTER ISLAND
Bangor.Flying.Circus-Bangor.Flying.Circus.1969.FLAC.CUE.Lossless	BANGOR FLYING CIRCUS BANGOR FLYING CIRCUS 1969
Kopy.V.Glubokom.Zapase.2010.DVD-9	KOPY V GLUBOKOM ZAPASE 2010
How.I.Met.Your.Mother.S04E20.rus.eng.HDTV.720p.[KuraJ-Bambey.Ru].mkv	HOW I MET YOUR MOTHER
Nas - Hip Hop Is Dead (Retail) (2006) (Malcko The Infamous)	NAS HIP HOP IS DEAD
[www.byte.to].Icarus.Uncut.German.2010.DVDRip.XviD-ViDEOWELT	ICARUS 2010
Hart.of.Dixie.2x11.mp4	HART OF DIXIE
Shawn.Michaels.MacMillan.River.Adventures.S01E09.HDTV.XviD-ECT.avi	SHAWN MICHAELS MACMILLAN RIVER ADVENTURES
--==WINDOWS 7 X86 SP1 v.1.2012 @SPA 2012(9.01.12)===	WINDOWS 7 2012
In the loop[DVDrip][AC3 5.1 Spanish][www.lokotorrents.com]	IN THE LOOP
[05,07] (7,3) The Misfits (1961) FR.avi	THE MISFITS
Auslogics.BoostSpeed.v5.0.5.240.Cracked-Kindly	AUSLOGICS BOOSTSPEED
Das_automatische_Gehirn_11.12.16_21-45_arte_45_TV00N_DE.mpg.mp4.otrkey	DAS AUTOMATISCHE GEHIRN ARTE 45
Man.From.Shaolin.2012.DVDRip.XviD-PTp0WeR	MAN FROM SHAOLIN 2012
Zero.2.2010.DVDRip.avi	ZERO 2 2010
The_Infinite_Vacation_03_(of_05)_(2011).cbz	THE INFINITE VACATION
Loft.Collection.1993-1996.MP3.320kbps.Paradise.Kinozal.TV	LOFT COLLECTION 1993 1996 PARADISE
Jack Reacher 2012 DutchReleaseTeam DVDRip[Xvid]AC3 5.1[FR] - YIFY	JACK REACHER 2012 RELEASETTEAM
The.Hobbit.2012.DVDScr.XVID.AC3.HQ.Hive-CM8	THE HOBBIT 2012
The Lonely Island - Incredibad [2009] FLAC	THE LONELY ISLAND
Saw VII (2010 Movie) DvdRip Xvid {1337x} X.avi	SAW VII
Ангел зла.2009.Blu-Ray.Remux.(1080p).mkv	АНГЕЛ ЗАЛА 2009
The Sims 3 Pets [Multi21] Crack + Keygen - sLayer2013.rar	THE SIMS 3 PETS
Epic (2013).DVDRip.XVID.AC3.HQ.Hive-CM8	EPIC
Wedding.Crashers[2005]DvDrip[Eng][Uncorked]-aXxo	WEDDING CRASHERS
Taken 2.2012.720p.BluRay.x264-playxd	TAKEN 2 2012
Criminal.Minds.Suspect.Behavior.S01.FRENCH.LD.DVDRip.XviD-JMT	CRIMINAL MINDS SUSPECT BEHAVIOR

Table J.1: Torrent Name Filtering Examples

## References

- Adult Film Database, 2015. Actor Advanced Search. Available at:  
<http://www.adultfilmdatabase.com/browse.cfm?type=actor> [Accessed March 5, 2015].
- Agena, 2016a. AgenaRisk Enterprise. Available at:  
<http://www.agenarisk.com/products/enterprise.shtml> [Accessed May 17, 2016].
- Agena, 2016b. AgenaRisk Free Version. Available at:  
[http://www.agenarisk.com/products/free\\_download.shtml](http://www.agenarisk.com/products/free_download.shtml) [Accessed May 17, 2016].
- Agena, 2016c. AgenaRisk: Bayesian Network and Simulation Software for Risk Analysis and Decision Support. Available at: <http://www.agenarisk.com/> [Accessed May 17, 2016].
- Altendorf, E.E., Restificar, A.C. & Dietterich, T.G., 2005. Learning from Sparse Data by Exploiting Monotonicity Constraints. In *Proceedings of the Twenty-First Conference on Uncertainty in Artificial Intelligence*. Edinburgh, Scotland: AUAI Press, pp. 18–26.
- Altschul, S. et al., 1990. Basic Local Alignment Search Tool. *Journal of Molecular Biology*, 215(3), pp.403–410.
- Amazon Mechanical Turk, 2015. Welcome. Available at:  
<https://www.mturk.com/mturk/welcome> [Accessed March 5, 2015].
- Angwin, J., Mcbride, S. & Smith, E., 2006. Record Labels Turn Piracy Into a Marketing Opportunity. *The Wall Street Journal*. Available at:  
<http://www.wsj.com/articles/SB116113611429796022> [Accessed May 14, 2015].
- Armstrong, J.S., 2012. Illusions in Regression Analysis. *International Journal of Forecasting*, 28(3), pp.689–694.
- Armstrong, S., 2001. Evaluating Forecasting Methods. In *Principles of Forecasting: a Handbook for Researchers and Practitioners*. pp. 443–472.

- Balabanović, M., 1997. An Adaptive Web Page Recommendation Service. In *Proceedings of the first international conference on Autonomous agents - AGENTS '97*. New York, New York, USA: ACM Press, pp. 378–385.
- Barber, D., 2012. *Bayesian Reasoning and Machine Learning*, Cambridge University Press.
- Bashir, A. et al., 2013. Classifying P2P Activity in Netflow Records: A Case Study on BitTorrent. In *Communications (ICC), 2013 IEEE International Conference on*. Budapest, Hungary, pp. 3018–3023.
- Bayes & Price, 1763. An Essay towards Solving a Problem in the Doctrine of Chances. By the Late Rev. Mr. Bayes, F. R. S. Communicated by Mr. Price, in a Letter to John Canton, A. M. F. R. S. *Philosophical Transactions*, 53, pp.370–418.
- Bayes Server, 2015. Bayes Server - Bayesian Network Software. Available at: <http://www.bayesserver.com/> [Accessed March 21, 2015].
- Biedermann, A. & Taroni, F., 2006. Bayesian Networks and Probabilistic Reasoning about Scientific Evidence when there is a Lack of Data. *Forensic Science International*, 157(2-3), pp.163–167.
- BitSnoop, 2015. BitSnoop New Torrents - Everything. *BitSnoop.com*. Available at: [http://bitsnoop.com/new\\_all.html?fmt=rss](http://bitsnoop.com/new_all.html?fmt=rss) [Accessed July 23, 2015].
- BitTorrent, 2015a. BitTorrent. Available at: <http://www.bittorrent.com/> [Accessed March 11, 2015].
- BitTorrent, 2015b. BitTorrent Bundle. *BitTorrent Website*. Available at: <https://bundles.bittorrent.com/> [Accessed June 8, 2015].
- BitTorrent, 2015c. BitTorrent Sync. *BitTorrent Inc. Sync Website*. Available at: <https://www.getsync.com/> [Accessed June 8, 2015].
- Borko, H. & Bernick, M., 1963. Automatic Document Classification. *Journal of the ACM*, 10(2), pp.151–161.
- Bravais, A., 1846. Analyse Mathematique sur les Probabilites des Erreurs de Situation d'un Point. *Memoires par divers Savans*, 9, pp.255–332.
- Breese, J.S. & Heckerman, D., 1996. Decision-Theoretic Troubleshooting: A Framework for Repair and Experiment. In *Proceedings of the Twelfth*

- International Conference on Uncertainty in Artificial Intelligence*. Morgan Kaufmann Publishers Inc., pp. 124–432.
- Brier, G.W., 1950. Verification of Forecasts Expressed in Terms of Probability. *Monthly Weather Review*, 78, pp.1–3.
- Buntine, W., 1991. Theory Refinement on Bayesian Networks. In *Proceedings of the Seventh conference on Uncertainty in Artificial Intelligence (UAI'91)*. Los Angeles, California, USA: Morgan Kaufmann Publishers Inc., pp. 52–60.
- Burnside, E.S. et al., 2006. Bayesian Network to Predict Breast Cancer Risk of Mammographic Microcalcifications and Reduce Number of Benign Biopsy Results: Initial Experience. *Radiology*, 240(3), pp.666–673.
- De Campos, C.P. & Qiang, J., 2008. Improving Bayesian Network Parameter Learning Using Constraints. In *Pattern Recognition, 2008. ICPR 2008. 19th International Conference on*. Tampa, FL: IEEE, pp. 1–4.
- Cano, A., Masegosa, A.R. & Moral, S., 2011. A Method for Integrating Expert Knowledge When Learning Bayesian Networks From Data. *Systems, Man, and Cybernetics, Part B: Cybernetics, IEEE Transactions on*, 41(5), pp.1382–1394.
- Caropreso, M.F., Matwin, S. & Sebastiani, F., 2001. A Learner-Independent Evaluation of the Usefulness of Statistical Phrases for Automated Text Categorization. *Text Databases and Document Management: Theory and Practice*, pp.78–102.
- Casella, G. & Berger, R.L., 1987. Reconciling Bayesian and Frequentist Evidence in the One-Sided Testing Problem. *Journal of the American Statistical Association*, 82(397), pp.106–111.
- Casey, R.M., 2005. BLAST Sequences Aid in Genomics and Proteomics. *BeyeNETWORK*. Available at: <http://www.b-eye-network.com/view/1730>.
- CCP Games, 2015. Downloading EVE. *EVElopedia*. Available at: [https://wiki.eveonline.com/en/wiki/Downloading\\_EVE](https://wiki.eveonline.com/en/wiki/Downloading_EVE) [Accessed June 8, 2015].
- Charalampos, R. et al., 2010. Probabilistic Graphical Models for Semi-Supervised Traffic Classification. In *Proceedings of the 6th International Wireless Communications and Mobile Computing Conference*. Caen, France: ACM, pp. 752–757.

- Christofides, N., 1975. *Graph Theory: An Algorithmic Approach*, Orlando, FL, USA: Academic Press, Inc.
- Cisco, 2015a. The Zettabyte Era - Trends and Analysis. *Cisco VNI*. Available at: [http://www.cisco.com/c/en/us/solutions/collateral/service-provider/visual-networking-index-vni/VNI\\_Hyperconnectivity\\_WP.html](http://www.cisco.com/c/en/us/solutions/collateral/service-provider/visual-networking-index-vni/VNI_Hyperconnectivity_WP.html) [Accessed May 31, 2015].
- Cisco, 2015b. VNI Forecast Highlights. *Cisco VNI*. Available at: [http://www.cisco.com/web/solutions/sp/vni/vni\\_forecast\\_highlights/index.html](http://www.cisco.com/web/solutions/sp/vni/vni_forecast_highlights/index.html) [Accessed January 6, 2015].
- Cobb, B.R. & Shenoy, P.P., 2006. Inference in Hybrid Bayesian Networks with Mixtures of Truncated Exponentials. *International Journal of Approximate Reasoning*, 41(3), pp.257–286.
- Cobham, A., 1964. The Intrinsic Computational Difficulty of Functions. In Y. Bar-Hillel, ed. *Proc. of the 1964 International Congress for Logic, Methodology, and the Philosophy of Science*. Amsterdam: North Holland, pp. 24–30.
- Cohen, B., 2011. The BitTorrent Protocol Specification. *BitTorrent.org*. Available at: [http://www.bittorrent.org/beps/bep\\_0003.html](http://www.bittorrent.org/beps/bep_0003.html) [Accessed May 17, 2016].
- Congalton, R. & Mead, R.A., 1983. A Quantitative Method to Test for Consistency and Correctness in Photointerpretation. *Photogrammetric Engineering & Remote Sensing*, 49(1), pp.69–74.
- Constantinou, A. & Fenton, N., 2012. Solving the Problem of Inadequate Scoring Rules for Assessing Probabilistic Football Forecast Models. *Journal of Quantitative Analysis in Sports*, 8(1), pp.1–14.
- Constantinou, A.C., Fenton, N. & Neil, M., 2012. pi-football: A Bayesian Network Model for Forecasting Association Football Match Outcomes. *Knowledge-Based Systems*, 36, pp.322–339.
- Cook, R.D. & Weisberg, S., 1982. Criticism and Influence Analysis in Regression. *Sociological Methodology*, 13, pp.313–361.
- Cooper, G.F., 1990. The Computational Complexity of Probabilistic Inference Using Bayesian Belief Networks. *Artificial Intelligence*, 42(2-3), pp.393–405.
- Coupé, V.M.H., Van Der Gaag, L.C. & Habbema, J., 2000. Sensitivity Analysis: An Aid for Belief-Network Quantification. *The Knowledge Engineering Review*, 15(3), pp.215–232.



- Cuevas, R. et al., 2010. Is Content Publishing in BitTorrent Altruistic or Profit-driven? In *Co-NEXT '10, Proceedings of the 6th International Conference*. Philadelphia, Pennsylvania: ACM, pp. 1–12.
- Dejean, S., 2009. What Can We Learn from Empirical Studies about Piracy? *CESifo Economic Studies*.
- Dementiev, E., 2015. Illustrative Material. *What's in a Name? Intelligent Classification and Identification of Online Media Content*. Available at: [http://thesis.som-service.com/illustrative\\_material/](http://thesis.som-service.com/illustrative_material/) [Accessed October 5, 2015].
- Díez, F.J. et al., 1997. DIAVAL, a Bayesian Expert System for Echocardiography. *Artificial Intelligence in Medicine*, 10(1), pp.59–79.
- Donnelly, P., 2005. Appealing Statistics. *Significance*, 2(1), pp.46–48.
- Duda, R.O. & Hart, P.E., 1973. *Pattern Classification and Scene Analysis*, Wiley.
- Eden, C., Ackermann, F. & Cropper, S., 1992. The Analysis of Cause Maps. *Journal of Management Studies*, 29(3), pp.309–204.
- Edwards, D., 2000. Directed Acyclic Graphs. In *Introduction to Graphical Modelling*. Springer, pp. 191–203.
- Enigmax, 2008. EA Choose BitTorrent for Warhammer Online Distribution. *TorrentFreak*. Available at: <https://torrentfreak.com/ea-choose-bittorrent-for-warhammer-online-distribution-080813/> [Accessed June 8, 2015].
- Envisional, 2011. *An Estimate of Infringing Use of the Internet*,
- Fawcett, T., 2006. An Introduction to ROC Analysis. *Pattern Recognition Letters*, 27(8), pp.861–874.
- Fenton, N., 2014. A Bayesian Network for a Simple Example of Drug Economics Decision Making. Available at: [https://www.eecs.qmul.ac.uk/~norman/papers/Drug\\_Economics.pdf](https://www.eecs.qmul.ac.uk/~norman/papers/Drug_Economics.pdf) [Accessed March 25, 2015].
- Fenton, N., 2012. A Short Story Illustrating Why Pure Machine Learning (Without Expert Input) May be Doomed to Fail and Totally Unnecessary. Available at: [http://www.eecs.qmul.ac.uk/~norman/papers/ml\\_simple\\_example.pdf](http://www.eecs.qmul.ac.uk/~norman/papers/ml_simple_example.pdf) [Accessed March 23, 2015].

- Fenton, N., 2015a. Another Machine Learning Fable. Available at:  
[https://www.eecs.qmul.ac.uk/~norman/papers/Another\\_machine\\_learning\\_fable.pdf](https://www.eecs.qmul.ac.uk/~norman/papers/Another_machine_learning_fable.pdf) [Accessed March 25, 2015].
- Fenton, N., 2015b. Moving from Big Data and Machine Learning to Smart Data and Causal Modelling: a Simple Example from Consumer Research and Marketing. Available at:  
[https://www.eecs.qmul.ac.uk/~norman/papers/The\\_problems\\_with\\_big\\_data.pdf](https://www.eecs.qmul.ac.uk/~norman/papers/The_problems_with_big_data.pdf) [Accessed March 25, 2015].
- Fenton, N. et al., 2007. Predicting Software Defects in Varying Development Lifecycles Using Bayesian Nets. *Information & Software Technology*, 49(1), pp.32–43.
- Fenton, N., 2011. Science and Law: Improve Statistics in Court. *Nature*, 479(7371), pp.36–37.
- Fenton, N. & Bieman, J., 2014. *Software Metrics: A Rigorous and Practical Approach* 3rd ed., CRC Press.
- Fenton, N. & Neil, M., 2012a. Causal Inference and Choosing the Correct Edge Direction. In *Risk Assessment and Decision Analysis with Bayesian Networks*. CRC Press, pp. 172–174.
- Fenton, N. & Neil, M., 2010. Comparing Risks of Alternative Medical Diagnosis Using Bayesian Arguments. *Journal of Biomedical Informatics*, 43(4), pp.485–495.
- Fenton, N. & Neil, M., 2012b. *Risk Assessment and Decision Analysis with Bayesian Networks*, CRC Press.
- Fenton, N. & Neil, M., 2012c. Structural Properties of BNs. In *Risk Assessment and Decision Analysis with Bayesian Networks*. CRC Press, pp. 144–151.
- Fenton, N. & Neil, M., 2012d. The Idioms. In *Risk Assessment and Decision Analysis with Bayesian Networks*. CRC Press, pp. 174–190.
- Fenton, N. & Neil, M., 2007. Using Ranked Nodes to Model Qualitative Judgements in Bayesian Networks. *Knowledge and Data Engineering, IEEE Transactions on*, 19(10), pp.1420–1432.
- Fenton, N., Neil, M. & Lagnado, D.A., 2013. A General Structure for Legal Arguments About Evidence Using Bayesian Networks. *Cognitive Science*, 37(1), pp.61–102.

- Fenton, N., Neil, M. & Lagnado, D.A., 2012. Modelling Mutually Exclusive Causes in Bayesian Networks. *Cognitive Science*, 37(1), pp.61–102.
- Fiot, C. et al., 2008. Learning Bayesian Network Structure from Incomplete Data without Any Assumption. In J. R. Haritsa, R. Kotagiri, & V. Pudi, eds. *Database Systems for Advanced Applications*. Springer Berlin Heidelberg, pp. 408–423.
- Flach, P.A., Hernandez-Orallo, J. & Ferri, C., 2011. A Coherent Interpretation of AUC as a Measure of Aggregated Classification Performance. In *Proceedings of the 28th International Conference on Machine Learning (ICML-11)*. pp. 657–664.
- Flores, M.J. et al., 2011. Incorporating Expert Knowledge when Learning Bayesian Network Structure: A Medical Case Study. *Artificial Intelligence in Medicine*, 53(3), pp.181–204.
- Freedman, D.A., 1991. Statistical Models and Shoe Leather. *Sociological Methodology*, 21, pp.291–313.
- Friedman, J.H., 1997. On Bias , Variance , 0 / 1 — Loss , and the Curse-of-Dimensionality. *Data Mining and Knowledge Discovery*, 1(1), pp.55–77.
- Friedman, N. et al., 2000. Using Bayesian Networks to Analyze Expression Data. *Journal of Computational Biology*, 7(3-4), pp.601–620.
- Friedman, N., Geiger, D. & Goldszmidt, M., 1997. Bayesian Network Classifiers G. Provan, P. Langley, & P. Smyth, eds. *Machine Learning*, 29(1), pp.131–163.
- Van der Gaag, L.C. et al., 2002. Probabilities for a Probabilistic Network: a Case Study in Oesophageal Cancer. *Artificial Intelligence in Medicine*, 25(2), pp.123–148.
- Gamma, E. et al., 1995. *Design Patterns: Elements of Reusable Object-oriented Software*, Addison-Wesley Longman Publishing Co., Inc.
- Gelman, A., 2008. Objections to Bayesian Statistics. *Bayesian Analysis*, 3(3), pp.445–449.
- Gelman, A., Bois, F. & Jiang, J., 1996. Physiological Pharmacokinetic Analysis Using Population Modeling and Informative Prior Distributions. *Journal of the American Statistical Association*, 91(436), pp.1400–1412.

- Gigerenzer, G., Hoffrage, U. & Ebert, A., 1998. AIDS Counselling for Low-Risk Clients. *AIDS Care*, 10(2), pp.197–211.
- Gizmo's Freeware, 2015. 30 Sites For Legal (and Free) Torrents. *TechSupportAlert.com*. Available at: <http://www.techsupportalert.com/content/finding-legal-and-free-torrents.htm> [Accessed May 17, 2016].
- Goldberg, A. & Robson, D., 1983. *Smalltalk-80: The Language*, Addison-Wesley Longman Publishing Co., Inc.
- Harrison, G.W., Martínez-Correa, J. & Swarthout, J.T., 2014. Eliciting Subjective Probabilities with Binary Lotteries. *Journal of Economic Behavior & Organization*, 101, pp.128–140.
- Hastings, R. & Wells, D., 2015. *Quarterly Earnings: Q1 15 Letter to Shareholders*,
- Hayes, P.J. et al., 1990. TCS: a Shell for Content-Based Text Categorization. In *CAIA-90, 6th IEEE Conference on Artificial Intelligence Applications*. Santa Barbara, CA, pp. 320–326.
- Heckerman, D., 2008. A Tutorial on Learning with Bayesian Networks. In D. E. Holmes & L. C. Jain, eds. *Innovations in Bayesian Networks*. Springer Berlin Heidelberg, pp. 33–82.
- Heckerman, D., 1990. Probabilistic Similarity Networks. *Networks*, 20(5), pp.607–636.
- Heckerman, D., Geiger, D. & Chickering, D.M., 1994. Learning Bayesian Networks: The Combination of Knowledge and Statistical Data. In *Proceedings of the Tenth International Conference on Uncertainty in Artificial Intelligence*. Seattle, WA: Morgan Kaufmann Publishers Inc., pp. 293–301.
- Henikoff, S. & Henikoff, J.G., 1992. Amino Acid Substitution Matrices from Protein Blocks. *Proceedings of the National Academy of Sciences of the USA*, 89(22), pp.10915–10919.
- Henrion, M., 1988. Propagating Uncertainty in Bayesian Networks by Probabilistic Logic Sampling. In J. F. Lemmer & L. N. Kanal, eds. *Uncertainty in Artificial Intelligence 2*. North Holland, pp. 149–163.
- Henrion, M., 1989. Some Practical Issues in Constructing Belief Networks. In L. N. Kanal, T. S. Levitt, & J. F. Lemmer, eds. *Uncertainty in Artificial Intelligence*. North-Holland, pp. 161–173.

- Horvitz, E. & Barry, M., 1995. Display of Information for Time-critical Decision Making. In *Proceedings of the Eleventh Conference on Uncertainty in Artificial Intelligence*. Montréal, Qué, Canada: Morgan Kaufmann Publishers Inc., pp. 296–305.
- Hugin, 2015. Hugin. Available at: <http://hugin.com/> [Accessed March 21, 2015].
- Hyndman, R. & Koehler, A., 2006. Another Look at Measures of Forecast Accuracy. *International Journal of Forecasting*, 22(4), pp.679–688.
- IFPI, 2015. *IFPI Digital Music Report 2015*,
- IMDb, 2015a. 01. *Internet Movie Database*. Available at: <http://www.imdb.com/title/tt1975798/> [Accessed March 11, 2015].
- IMDb, 2015b. 2. *Internet Movie Database*. Available at: <http://www.imdb.com/title/tt2168970/> [Accessed March 11, 2015].
- IMDb, 2015c. Air. *Internet Movie Database*. Available at: <http://www.imdb.com/title/tt2091478/> [Accessed March 11, 2015].
- IMDb, 2016. Alternative Interfaces. *Internet Movie Database*. Available at: <http://www.imdb.com/interfaces/> [Accessed May 17, 2016].
- IMDbPY, 2015. IMDbPY. *Sourceforge*. Available at: <http://imdbpy.sourceforge.net/> [Accessed March 11, 2015].
- Internet Archive, 2016. Archive Torrents. *Internet Archive Website*. Available at: <https://archive.org/details/bittorrent> [Accessed May 17, 2016].
- Internet World Stats, 2014. Internet Growth Statistics. *Internet World Stats*. Available at: <http://www.internetworldstats.com/emarketing.htm> [Accessed March 11, 2015].
- Jackson, M.A., 1995. *Software Requirements & Specifications: A Lexicon of Practice, Principles and Prejudices*, ACM Press/Addison-Wesley.
- Jansen, R. et al., 2003. A Bayesian Networks Approach for Predicting Protein-Protein Interactions from Genomic Data. *Science*, 302(5644), pp.449–453.
- Jensen, F.V. & Nielsen, T.D., 2007. Propagation in Junction Trees. In *Bayesian Networks and Decision Graphs*. Springer, pp. 124–130.

- Jiang, X. et al., 2011. Learning Genetic Epistasis Using Bayesian Network Scoring Criteria. *BMC Bioinformatics*, 12(1), p.89.
- Kendall, M.G., 1949. On the Reconciliation of Theories of Probability. *Biometrika*, 36(1-2), pp.101–116.
- Keppens, J., 2011. On Extracting Arguments from Bayesian Network Representations of Evidential Reasoning. In *ICAAIL'11 Proceedings of the 13th International Conference on Artificial Intelligence and Law*. Pittsburgh, PA: ACM, pp. 141–150.
- Khan, O.Z., Poupart, P. & Agosta, J.M., 2011. Automated Refinement of Bayes Networks' Parameters Based on Test Ordering Constraints. In J. Shawe-Taylor et al., eds. *Advances in Neural Information Processing Systems 24*. Curran Associates, Inc., pp. 2591–2599.
- Koller, D. & Friedman, N., 2009. Box 3.C - Skill: Knowledge Engineering. In *Probabilistic Graphical Models: Principles and Techniques*. MIT Press, pp. 64–68.
- Koller, D. & Pfeffer, A., 1997. Object-Oriented Bayesian Networks. In *Proceedings of the Thirteenth Conference on Uncertainty in Artificial Intelligence*. Providence, Rhode Island: Morgan Kaufmann Publishers Inc., pp. 302–313.
- Koski, T. & Noble, J., 2009. *Bayesian Networks: An Introduction* 1st ed., John Wiley & Sons.
- Kozlov, A. V. & Koller, D., 1997. Nonuniform Dynamic Discretization in Hybrid Networks. In *Proceedings of the Thirteenth Conference on Uncertainty in Artificial Intelligence*. Providence, Rhode Island: Morgan Kaufmann Publishers Inc., pp. 314–325.
- Kschischang, F.R., Frey, B.J. & Loeliger, H.A., 2001. Factor Graphs and the Sum-Product Algorithm. *Information Theory, IEEE Transactions on*, 47(2), pp.498–519.
- Laitila, P. & Virtanen, K., 2016. Improving Construction of Conditional Probability Tables for Ranked Nodes in Bayesian Networks. *IEEE Transactions on Knowledge and Data Engineering*, PP(99), pp.1–14.
- Langley, P., Iba, W. & Thompson, K., 1992. An Analysis of Bayesian Classifiers. In W. Swartout, ed. *Proceedings of the Tenth National Conference on Artificial Intelligence*. AAAI'92. AAAI Press, pp. 223–228.

- Laskey, K.B., 1995. Sensitivity Analysis for Probability Assessments in Bayesian Networks. *Systems, Man and Cybernetics, IEEE Transactions on*, 25(6), pp.901–909.
- Laskey, K.B. & Levitt, T.S., 2002. Multisource Fusion for Opportunistic Detection and Probabilistic Assessment of Homeland Terrorist Threats. In *AeroSense 2002*. Orlando, Florida, USA: International Society for Optics and Photonics, pp. 80–89.
- Laskey, K.B. & Mahoney, S., 2000. Network Engineering for Agile Belief Network Models. *Knowledge and Data Engineering, IEEE Transactions on*, 12(4), pp.487–498.
- Laskey, K.B. & Mahoney, S.M., 1997. Network Fragments: Representing Knowledge for Constructing Probabilistic Models. In *Proceedings of the Thirteenth conference on Uncertainty in artificial intelligence*. San Francisco: Morgan Kaufmann Publishers Inc., pp. 334–341.
- Lauritzen, S.L., 1992. Propagation of Probabilities, Means, and Variances in Mixed Graphical Association Models. *Journal of the American Statistical Association*, 87(420), pp.1098–1108.
- Lauritzen, S.L. & Jensen, F., 2001. Stable Local Computation with Conditional Gaussian Distributions. *Statistics and Computing*, 11(2), pp.191–203.
- Lauritzen, S.L. & Spiegelhalter, D.J., 1988. Local Computations with Probabilities on Graphical Structures and Their Application to Expert Systems. *Journal of the Royal Statistical Society. Series B (Methodological)*, 50(2), pp.157–224.
- Lewis, D.D., 1992. An Evaluation of Phrasal and Clustered Representations on a Text Categorization Task. In *Proceedings of SIGIR-92, 15th ACM International Conference on Research and Development in Information Retrieval*. Copenhagen, Denmark: ACM, pp. 37–50.
- Lewis, D.D., 1998. Naive (Bayes) at Forty: The Independence Assumption in Information Retrieval. In C. Nédellec & C. Rouveirol, eds. *10th European Conference on Machine Learning*. Chemnitz, Germany: Springer Berlin Heidelberg, pp. 4–15.
- Li, H. & Homer, N., 2010. A Survey of Sequence Alignment Algorithms for Next-Generation Sequencing. *Briefings in Bioinformatics*, 11(5), pp.473–483.
- Lovins, J.B., 1968. Development of a Stemming Algorithm. *Mechanical Translation and Computational Linguistics*, 11, pp.22–31.

- Lunn, D.J. et al., 2000. WinBUGS - A Bayesian Modelling Framework: Concepts, Structure, and Extensibility. *Statistics and Computing*, 10(4), pp.325–337.
- Maron, M.E., 1961. Automatic Indexing: An Experimental Inquiry. *Journal of the ACM*, 8(3), pp.404–417.
- Marquez, D., Neil, M. & Fenton, N., 2010. Improved Reliability Modeling Using Bayesian Networks and Dynamic Discretization. *Reliability Engineering & System Safety*, 95(4), pp.412–425.
- Marsh, W. & Bearfield, G., 2004. Using Bayesian Networks to Model Accident Causation in the UK Railway Industry. In *Probabilistic Safety Assessment and Management (PSAM7)*. Springer, pp. 3597–3602.
- Masnick, M., 2015. MPAA's Lies About Films Being Available Online Easily Debunked In Seconds. *Techdirt*.
- Matthews, B.W., 1975. Comparison of the Predicted and Observed Secondary Structure of T4 Phage Lysozyme. *Biochimica et Biophysica Acta (BBA) - Protein Structure*, 405(2), pp.442–451.
- McGrayne, S.B., 2011. *The Theory That Would Not Die*, Yale University Press.
- McGrayne, S.B., 2012. *The Theory That Would Not Die: How Bayes' Rule Cracked the Enigma Code, Hunted Down Russian Submarines, and Emerged Triumphant from Two Centuries of Controversy* Reprint Ed., Yale University Press.
- Meritt, 2010. Complete Game Client Torrent Available! *Rift Game Tech Support Forums*. Available at: <http://forums.riftgame.com/technical-discussions/tech-support/89277-complete-game-client-torrent-available.html> [Accessed June 8, 2015].
- Meyer, B., 1998. *Object-Oriented Software Construction*, Prentice Hall New York.
- Milot, M.R., 2014. Testing the Lost Sale Concept in the Context of Unauthorized BitTorrent Downloads of CAM Copies of Theatrical Releases. *APAS Laboratory*.
- Mitchell, T., 1996. *Machine Learning*, McGraw Hill.
- Moore, A.W. & Zuev, D., 2005. Internet Traffic Classification Using Bayesian Analysis Techniques. *SIGMETRICS Perform. Eval. Rev.*, 33(1), pp.50–60.
- MovieLabs, 2012. in a private meeting.



- MovieLabs, 2016. Motion Pictures Laboratories, Inc. *MovieLabs Website*. Available at: <http://www.movielabs.com/> [Accessed May 17, 2016].
- MovieLabs, 2014. MovieLabs Source Code.
- Murphy, K., 2012. Graphical Model Structure Learning. In *Machine Learning: A Probabilistic Perspective*. MIT Press, pp. 909–949.
- Murphy, K., 2014. Software Packages for Graphical Models. Available at: <http://www.cs.ubc.ca/~murphyk/Software/bnsoft.html> [Accessed March 21, 2015].
- MySQL, 2015. MySQL: The world's most popular open source database. Available at: <http://www.mysql.com/> [Accessed March 11, 2015].
- Nadkarni, S. & Shenoy, P.P., 2001. A Bayesian Network Approach to Making Inferences in Causal Maps. *European Journal of Operational Research*, 128, pp.479–798.
- Nadkarni, S. & Shenoy, P.P., 2004. A Causal Mapping Approach to Constructing Bayesian Networks. *Decision Support Systems*, 38(2), pp.259–281.
- Nakamoto, S., 2008. Bitcoin: A Peer-to-Peer Electronic Cash System. *Consulted*, 1(2012).
- Neapolitan, R.E., 2003. *Learning Bayesian Networks*, Prentice Hall.
- Needleman, S.B. & Wunsch, C.D., 1970. A General Method Applicable to the Search for Similarities in the Amino Acid Sequence of Two Proteins. *Journal of Molecular Biology*, 48(3), pp.443–453.
- Neil, M. et al., 2001. Using Bayesian Belief Networks to Predict the Reliability of Military Vehicles. *Computing Control Engineering Journal*, 12(1), pp.11–20.
- Neil, M., Fenton, N. & Marquez, D., 2007. Using Bayesian Networks and Simulation for Data Fusion and Risk Analysis. In D. Skanata & D. M. Byrd, eds. *NATO Science for Peace and Security Series: Information and Communication Security*. Amsterdam: IOS Press, pp. 204–216.
- Neil, M., Fenton, N. & Nielson, L., 2000. Building Large-Scale Bayesian Networks. *The Knowledge Engineering Review*, 15(3), pp.257–284.

- Neil, M., Malcolm, B. & Shaw, R., 2003. Modelling an Air Traffic Control Environment Using Bayesian Belief Networks. In *International System Safety Conference*. Ottawa, Ontario Canada.
- Nielsen, T.D. & Jensen, F.V., 2009. *Bayesian Networks and Decision Graphs*, Springer Science & Business Media.
- O'Hagan, A. et al., 2006. *Uncertain judgements: Eliciting experts' probabilities*, John Wiley & Sons.
- Ofcom Communications, 2013. Average UK Broadband Speed Continues to Rise. *News Releases 2013*. Available at: <http://media.ofcom.org.uk/news/2013/average-uk-broadband-speed-continues-to-rise/> [Accessed July 14, 2015].
- OpenOffice, 2015. OpenOffice.org P2P Downloads. *OpenOffice Website*. Available at: <http://www.openoffice.org/distribution/p2p/magnet.html> [Accessed June 8, 2015].
- Paul, R., 2012. Exclusive: A Behind-the-Scenes Look at Facebook Release Engineering. *Ars Technica*. Available at: <http://arstechnica.com/business/2012/04/exclusive-a-behind-the-scenes-look-at-facebook-release-engineering/> [Accessed June 8, 2015].
- Pazzani, M., Muramatsu, J. & Billsus, D., 1996. Syskill & Webert: Identifying Interesting Web Sites. In *13th National Conference on Artificial Intelligence*. Portland, pp. 69–77.
- Pearl, J., 1988. *Probabilistic Reasoning in Intelligent Systems: Networks of Plausible Inference*, Morgan Kaufmann Publishers Inc.
- Pearl, J., 1982. Reverend Bayes on Inference Engines: A Distributed Hierarchical Approach. In *Proceedings of the Second National Conference on Artificial Intelligence (AAAI-82)*. Pittsburgh, PA: AAAI Press, pp. 133–136.
- Pearl, J., 2009. The Logic of Structure-Based Counterfactuals. In *Causality: Models, Reasoning and Inference*. Cambridge University Press, pp. 201–259.
- Pearson, K., 1896. Mathematical Contributions to the Theory of Evolution. III. Regression, Heredity and Panmixia. *Philosophical Transactions of the Royal Society of London*, 187, pp.253–318.

- Pocklington, H.C., 1911. The Determination of the Exponent to which a Number Belongs, the Practical Solution of Certain Congruences, and the Law of Quadratic Reciprocity. *Math. Proc. Cambr. Phil. Soc.*, 16, pp.1–5.
- Porter, M.F., 1980. An Algorithm for Suffix Stripping. *Program: Electronic Library and Information Systems*, 14(3), pp.130–137.
- Pourret, O., Naïm, P. & Marcot, B., 2008. *Bayesian Networks: A Practical Guide to Applications (Statistics in Practice)*, Wiley-Blackwell.
- Powers, D.M.W., 2011. Evaluation: From Precision, Recall and F-Measure To ROC, Informedness, Markedness & Correlation. *Journal of Machine Learning Technologies*, 2(1), pp.37–63.
- Pradhan, M. et al., 1994. Knowledge Engineering for Large Belief Networks. In R. L. de Mantaras & D. Poole, eds. *Uncertainty in Artificial Intelligence 1994: Proceedings of the 10th Conference*. Seattle, WA: Morgan Kaufmann Publishers Inc., pp. 484–491.
- Qmee, 2013. What happens online in 60 seconds? [Infographic]. Qmee. Available at: <http://blog.qmee.com/qmee-online-in-60-seconds/> [Accessed March 11, 2015].
- Renooij, S., 2010. Bayesian Network Sensitivity to Arc-Removal. In *Proceedings of the Fifth European Workshop on Probabilistic Graphical Models (PGM-2010)*. pp. 233–241.
- Renooij, S., 2001. Probability Elicitation for Belief Networks: Issues to Consider. *The Knowledge Engineering Review*, 16(3), pp.255–269.
- Roby, T.B., 1964. *Belief States: A Preliminary Empirical Study*,
- Rumbaugh, J. et al., 1991. *Object-Oriented Modeling and Design* 3rd ed., Prentice-Hall Englewood Cliffs.
- Rumí, R., Salmerón, A. & Moral, S., 2006. Estimating Mixtures of Truncated Exponentials in Hybrid Bayesian Networks. *Test*, 15(2), pp.397–421.
- Sahami, M., 1996. Learning Limited Dependence Bayesian Classifiers. In *KDD96 Proceedings of the Second International Conference on Knowledge Discovery and Data Mining*. AAAI Press, pp. 335–338.
- Salton, G., 1989. *Automatic Text Processing: The Transformation, Analysis, and Retrieval of Information by Computer*, Addison-Wesley.

- Salton, G., Wong, A. & Yang, C., 1975. A Vector Space Model for Automatic Indexing. *Communications of the ACM*, 18(11), pp.613–620.
- Sandvine, 2014. Global Internet Phenomena Report. *Sandvine: Trends*.
- Savage, L.J., 1971. Elicitation of Personal Probabilities and Expectations. *Journal of the American Statistical Association*, 66(336), pp.783–801.
- Schollmeier, R., 2001. A Definition of Peer-to-Peer Networking for the Classification of Peer-to-Peer Architectures and Applications. In *Peer-to-Peer Computing, 2001. Proceedings. First International Conference on*. Linköping, Sweden, pp. 101–102.
- Sebastiani, F., 2002. Machine Learning in Automated Text Categorization. *ACM Computing Surveys (CSUR)*, 34(1), pp.1–47.
- Seber, G.A.F. & Lee, A.J., 2003. Linear Regression: Estimation and Distribution Theory. In *Linear Regression Analysis*. Wiley-Interscience, pp. 35–97.
- Senn, S., 2011. You May Believe You Are a Bayesian But You Are Probably Wrong. *Rationality, Markets and Morals*, 2(42), pp.48–66.
- Shuford, E.H., Albert, A. & Massengill, H.E., 1966. Admissible Probability Measurement Procedures. *Psychometrika*, 31(2), pp.125–145.
- Siwek, S.E., 2006. *The True Cost of Motion Picture Piracy to the U.S. Economy*,
- Skaaning, C. et al., 2003. Automated Diagnosis of Printer Systems Using Bayesian Networks. *U.S. Patent 6 535 865*.
- Smith, M.D. & Telang, R., 2012. Assessing the Academic Literature Regarding the Impact of Media Piracy on Sales. *SSRN*.
- Smith, M.D. & Telang, R., 2009. Piracy or Promotion? The Impact of Broadband Internet Penetration on DVD Sales. *SSRN*.
- Smith, T.F. & Waterman, M.S., 1981. Identification of Common Molecular Subsequences. *Journal of Molecular Biology*, 147, pp.195–197.
- Spiegelhalter, D.J. et al., 1993. Bayesian Analysis in Expert Systems. *Statistical Science*, 8(3), pp.219–247.
- Stan Development Team, 2014. Stan: A C++ Library for Probability and Sampling, Version 2.5.0. Available at: <http://mc-stan.org> [Accessed March 21, 2015].

- Stockholm District Court, 2009. Case no B 13301-06. *www.ifpi.org*. Available at: <http://www.ifpi.org/content/library/Pirate-Bay-verdict-English-translation.pdf> [Accessed August 26, 2015].
- Stockholms Tingsrätt, 2009. Dom 2009-04-17 i mål nr B 13301-06. Available at: <http://www.sr.se/Diverse/AppData/Isidor/files/83/6277.pdf> [Accessed August 26, 2015].
- Studer, R., Benjamins, V.R. & Fensel, D., 1998. Data & Knowledge Engineering. *Data & Knowledge Engineering, Elsevier*, 25(1-2), pp.161–197.
- Thulasiraman, K. & Swamy, M.N.S., 1992. Acyclic Directed Graphs. In *Graphs: Theory and Algorithms*. John Wiley and Son, pp. 118–119.
- Toda, M., 1963. *Measurement of Subjective Probability Distributions*,
- Tonkin, E., Chen, A. & Waters, M., 2013. *MovieLabs Interim Report*, University of Bath, UK.
- Tru Optik, 2014. *Digital Media Unmonetized Demand and Peer-to-Peer File Sharing Report*, Stamford, CT.
- Tversky, A. & Kahneman, D., 1974. Judgment under Uncertainty: Heuristics and Biases. *Science*, 185(4157), pp.1124–1131.
- Ubuntu, 2015. Alternative Downloads. *Ubuntu Website*. Available at: <http://www.ubuntu.com/download/alternative-downloads> [Accessed June 8, 2015].
- W3C, 2008. Extensible Markup Language (XML) 1.0 (Fifth Edition). *W3C Recommendation*. Available at: <http://www.w3.org/TR/REC-xml/> [Accessed August 17, 2015].
- Wellman, M.P., 1990. Fundamental Concepts of Qualitative Probabilistic Networks. *Artificial Intelligence*, 44(3), pp.257–303.
- Wikia, 2015. Blizzard Downloader. *WoWWiki*. Available at: [http://wowwiki.wikia.com/Blizzard\\_Downloader](http://wowwiki.wikia.com/Blizzard_Downloader) [Accessed June 8, 2015].
- Wikipedia, 2016. MediaDefender. *Wikipedia, The Free Encyclopedia*. Available at: <https://en.wikipedia.org/wiki/MediaDefender> [Accessed May 17, 2016].
- Wolinsky, D.I. et al., 2010. On the Design of Autonomic, Decentralized VPNs. In *Collaborative Computing: Networking, Applications and Worksharing*

- (CollaborateCom), 2010 6th International Conference on. Chicago, USA: IEEE, pp. 1–10.
- YouTube, 2012. Holy Nyans! 60 Hours per Minute and 4 Billion Views a Day on YouTube. *YouTube Official Blog*. Available at: <http://youtube-global.blogspot.co.uk/2012/01/holy-nyans-60-hours-per-minute-and-4.html> [Accessed November 16, 2015].
- Youtube Press, 2015. Statistics. *Youtube Press Statistics*. Available at: <http://youtube.com/yt/press/statistics.html> [Accessed May 31, 2015].
- Zagorecki, A. & Druzdzal, M.J., 2004. An Empirical Study of Probability Elicitation Under Noisy-OR Assumption. In *FLAIRS Conference*. AAAI Press, pp. 880–886.
- Zhang, C. et al., 2011. Unraveling the BitTorrent Ecosystem. *Parallel and Distributed Systems, IEEE Transactions on*, 22(7), pp.1164–1177.
- Zhou, Y. et al., 2015. Probabilistic Graphical Models Parameter Learning with Transferred Prior and Constraints. In *31st Conference on Uncertainty in Artificial Intelligence (UAI 2015)*. pp. 972–981.
- Zhou, Y., Fenton, N. & Neil, M., 2014. Bayesian Network Approach to Multinomial Parameter Learning using Data and Expert Judgments. *International Journal of YApproximate Reasoning*, 55(5), pp.1252–1268.
- Zwillinger, D. & Kokoska, S., 2000. *CRC Standard Probability and Statistics Tables and Formulae*, CRC Press.