



**Deliverable 4.5: Mooring and Foundation Module
Framework for DTOcean Tool**

Lead partner:	The University of Exeter (UNEXE)
Contributing partners:	DEME Blue Energy (DBE), MARINTEK (MRTK), Sandia National Laboratories (SNL), Tecnalia, University College Cork (UCC), WavEC – Offshore Renewables (WavEC), Tension Technology International Ltd (TTI), University of Edinburgh (UEDIN), Aalborg University (AAU)
Authors:	Sam Weller, Lars Johanning, Lander Victor, Madjid Karimirad, Jason Heath, John Eddy, Richard Jensen, Jesse Roberts, Stephen Banfield



This project has received funding from the European Union's Seventh Programme for research, technological development and demonstration under grant agreement No 608597

Deliverable 4.5: Mooring and Foundation Module Framework for DTOcean Tool

Project: DTOcean - Optimal Design Tools for Ocean Energy Arrays

Code: DTO_WP4_ECD_D4.5

	Name	Date
Prepared	Work Package 4	16/01/2015
Checked	Work Package 9	21/01/2015
Approved	Project Coordinator	27/01/2015

The research leading to these results has received funding from the European Community's Seventh Framework Programme under grant agreement No. 608597 (DTOcean).

No part of this publication may be reproduced, stored in a retrieval system, or transmitted in any form – electronic, mechanical, photocopy or otherwise without the express permission of the copyright holders.

This report is distributed subject to the condition that it shall not, by way of trade or otherwise, be lent, re-sold, hired-out or otherwise circulated without the publishers prior consent in any form of binding or cover other than that in which it is published and without a similar condition including this condition being imposed on the subsequent purchaser.

DOCUMENT CHANGES RECORD			
<i>Edit./Rev.</i>	<i>Date</i>	<i>Chapters</i>	<i>Reason for change</i>
A/0	02/12/2014	All	New document
1.0	05/01/2015	All	Revised draft
2.0	18/01/2015	All	Final draft
3.0			

Abstract

The Optimal Design Tools for Ocean Energy Arrays project (DTOcean) is developing a system-level tool to assess cost, reliability, and environmental impact for marine renewable energy (MRE) systems. The DTOcean Tool will integrate several modules covering key aspects of MRE systems (i.e., array layout, moorings and foundations, electrical infrastructure, logistics, in addition to operations and maintenance). This report outlines the proposed architecture and main functions of the DTOcean mooring and foundation design module (the Work Package 4 or WP4 module) and its interaction with other elements and modules of the Tool. This document therefore presents the WP4 module framework which will be populated with algorithms and functions as the Tool is further developed. The module will comprise five sub-modules, in which calculations will be performed to determine and/or design the system and environmental loads, the electrical umbilical, mooring, and foundation systems as well as the foundation required for the electrical substation. Calculations performed in the sub-modules will be based on inputs provided by the user, other Tool modules, and data stored within the global Tool database. Criteria for determining design suitability will not be based solely on whether the specified components are suitable for keeping the device in position. The capital cost of each configuration will be estimated within the WP4 module, with reliability and environmental impact assessments also performed within the Tool. The framework of the WP4 module draws upon findings of previous WP4 deliverables, in which applicable mooring and foundation technologies and methods for their analysis have been reported.

TABLE OF CONTENTS

<i>Chapter</i>	<i>Description</i>	<i>Page</i>
1	WP4 MOORING AND FOUNDATION DESIGN MODULE OVERVIEW.....	9
1.1	MODULE AIMS.....	9
1.2	DATAFLOW TO AND FROM THE WP4 MODULE	9
1.2.1	First run of the module	9
1.2.2	Subsequent runs of the module	10
1.3	DATAFLOW WITHIN THE WP4 MODULE.....	11
1.3.1	Floating system	12
1.3.2	Fixed system.....	13
2	WP4 MODULE INPUTS	15
2.1	DATA FORMATS.....	15
2.2	SITE SPECIFIC INPUTS.....	16
2.3	TECHNOLOGY SPECIFIC INPUTS.....	19
3	OVERVIEW OF THE PROPOSED ANALYSIS PROCEDURE	22
3.1	DESIGN STANDARDS.....	22
3.1.1	Limit States.....	22
3.1.2	Foundation design	23
3.1.3	Mooring system design.....	26
3.2	APPLICABILITY OF EXISTING STANDARDS TO MRE DEVICES AND THE DTOCEAN DESIGN TOOL.....	27
3.3	FLOWCHART CONVENTIONS	29
3.4	PROPOSED ANALYSIS PROCEDURE.....	29
3.4.1	WP4 module	29
3.4.2	System and environmental loads sub-module	30
3.4.3	Umbilical sub-module	32
3.4.4	Mooring sub-module	32
3.4.5	Foundation sub-module.....	35
3.4.6	Substation sub-module.....	36
4	WP4 MODULE OUTPUTS	38
5	CONCLUSIONS	40
6	BIBLIOGRAPHY.....	41

TABLE OF CONTENTS

<i>Chapter</i>	<i>Description</i>	<i>Page</i>
7	APPENDIX A1 – WP4 FLOWCHART REPRESENTATION	43
8	APPENDIX A2 - PROPOSED FOUNDATION SUB-MODULE DECISION MATRIX	44
9	APPENDIX A3 – POSSIBLE COMPONENT SELECTION PROCEDURE	46
10	APPENDIX A4 - POSSIBLE WP4 MODULE OUTPUTS	48

TABLES INDEX

<i>Description</i>	<i>Page</i>
Table 1: High-level processes for a floating system	12
Table 2: High-level processes for a fixed system	13
Table 3: An example of a nominal parameter: soil type	15
Table 4: Examples of numeric parameters specified as ranges (taken from [1])	15
Table 5: Site-specific module inputs	18
Table 6: Technology-specific module inputs (parameters shared with other modules are indicated by shading)	21
Table 7: Environmental load type and return period to define characteristic value of corresponding load effect (from [8]) .	25
Table 8: Environmental load type and return period to define characteristic value of corresponding load effect (from [4]).	26
Table 9: Partial safety factors used in ULS and ALS analysis (from [4])	26
Table 10: Tension limits and equipment safety factors used in Intact and Damaged state analysis (from [16])	27
Table 11: Environmental load type and return period to define characteristic value of corresponding load effect (from [4]). Note: the water level return period is taken from [8]	28
Table 12: WP4 module outputs	39
Table 13: Soil matrix listing the performance of foundation and anchor types as a function of seafloor conditions	44
Table 14: Topography matrix	44
Table 15: Sensitivity to soil depth matrix	44
Table 16: Load direction matrix	44
Table 17: Load magnitude matrix	45
Table 18: Parameter names for the example shown in Figure 16	48

FIGURES INDEX

<i>Description</i>	<i>Page</i>
Figure 1: High-level dataflow to and from the WP4 mooring and foundation module	9
Figure 2: Constraint feedback from the WP5 and WP6 modules	10
Figure 3: High-level dataflow within the WP4 mooring and foundation module	11
Figure 4: High-level dataflow within the WP4 module for a floating system	13
Figure 5: High-level dataflow within the WP4 module for a fixed system	14
Figure 6: Design values for the coefficient of subgrade soil reaction used in pile design (taken from [1])	16
Figure 7: Illustrative data hierarchy at each grid point	16 ⁷

Figure 8: Process blocks and boundaries used in the flowchart 29

Figure 9: (left) Connection or shared dataflow, (right) no connection or shared dataflow..... 29

Figure 10: Functions within the System and environmental loads sub-module 30

Figure 11: The relationship between wave parameters, structure size and wave forces (taken from [11])..... 31

Figure 12: Functions within the Umbilical sub-module 32

Figure 13: Functions within the Mooring sub-module 33

Figure 14: Functions within the Foundation sub-module 35

Figure 15: Functions within the Substation sub-module 37

Figure 16: Example mooring configuration comprising identical components in each of the three mooring lines..... 48

1 WP4 MOORING AND FOUNDATION DESIGN MODULE OVERVIEW

1.1 Module aims

The DTOcean Tool is primarily a system-level decision tool which comprises several modules whose purpose is to determine design solutions in the following key areas: array layout, moorings and foundations, electrical infrastructure, logistics, and operations and maintenance. The main aim of the DTOcean mooring and foundation design module (covered by Work Package 4 or WP4 of the DTOcean project) is to perform static and quasi-static analysis to inform or develop mooring and foundation solutions that:

- are suitable for a given site, the MRE device (and substation), and expected loading conditions;
- retain the integrity of the electrical umbilical that connects the MRE device to the subsea cable;
- are compatible with the array layout (i.e., prevents clashing of neighbouring devices) and subsea cable layout;
- fulfil requirements and/or constraints determined by the user and/or in terms of reliability and/or environmental concerns; and
- have the lowest capital cost.

1.2 Dataflow to and from the WP4 module

1.2.1 First run of the module

Referring to Figure 1 it is proposed that the dataflow through the DTOcean Design Tool will be linear, starting with WP2: array layout and followed by WP3: electrical infrastructure.

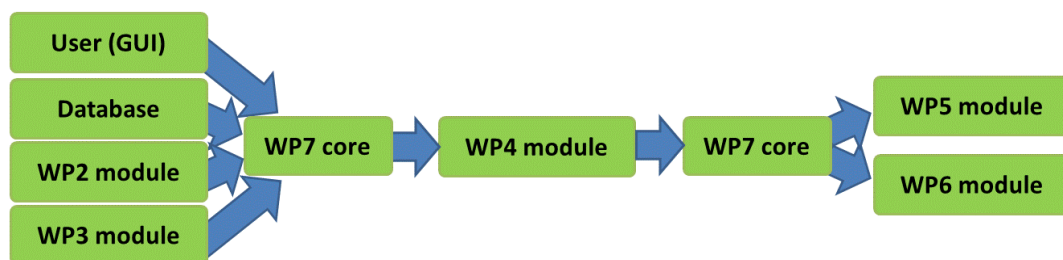

Figure 1: High-level dataflow to and from the WP4 mooring and foundation module

The next module, WP4 will be used to develop a suitable mooring and/or foundation solution based on a set of inputs supplied by i) the user (via the graphical user interface or GUI), ii) the WP2 (array layout) and WP3 modules (umbilical requirements and subsea infrastructure details) and iii) from the

global Tool database. These inputs will be routed to the WP4 module via the WP7 core of the Tool which will pass information between the global Tool database, the design modules and the user.

In all likelihood more than one solution may be technologically feasible for a given set of input values and constraints. If multiple solutions exist, the solution with the lowest capital cost will be passed to WP5: lifecycle logistics and WP6: system control and operation via the WP7 core. In WP5 the cost of mooring and/or foundation installation, operation and maintenance will be added to the capital cost of components calculated in WP4. The reliability of the solution will be assessed in WP6, based on the component hierarchy generated by WP4 and using component failure rates stored in the database. The environmental impact of the mooring and/or foundation system will be assessed via additional functions within the WP4 module but at the time of writing these have yet to be defined.

1.2.2 Subsequent runs of the module

If the solution is not feasible in terms of its economic, reliability or environmental impact metrics or logistical feasibility, an alternative mooring or foundation solution will be sought by initialising a subsequent run of the Tool. Subsequent runs of the WP4 module will be constrained by feedback provided by WP5, WP6 and the environmental impact algorithms (Figure 2).

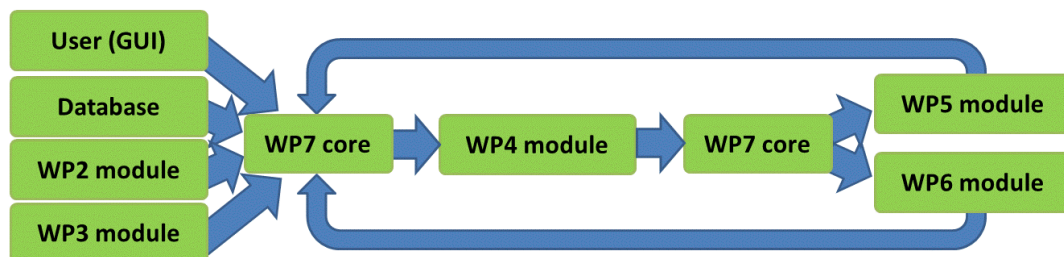

Figure 2: Constraint feedback from the WP5 and WP6 modules

Several example scenarios necessitating feedback to the WP4 module could be:

- If the environmental impact of pile foundations is unacceptable for the site due to installation noise, piles would be unavailable for selection in the next run of the *Foundation sub-module* (more specifically in the *Foundation type decision tree* introduced in Section 3.4.5). Alternatively remedial measures could be suggested (i.e. the use of a bubble curtain to reduce noise propagation).
- The specification of particularly large anchor might incur prohibitive installation costs (calculated by WP5) because of the requirement to specify an Anchor Handling Tug which has high charter costs for a particular location. Such costs may have an adverse effect on the overall levelised cost of energy (LCOE). In the next run of the *Mooring sub-module* the selection of mooring components would be constrained to prevent large anchors from being

selected and perhaps other technologies considered (an example of component selection is given in Appendix A3).

- If the reliability of the proposed system (as calculated by the WP6 module) is unacceptable then similarly to the previous example a constraint would be set. Therefore only components with a reliability level above a specified threshold would be available for selection when the WP4 module is re-run¹.

1.3 Dataflow within the WP4 module

Referring to Figure 3 the WP4 module comprises five interlinked sub-modules:

- *System and environmental loads sub-module*
- *Umbilical sub-module*
- *Mooring system sub-module*
- *Foundation sub-module*
- *Substation sub-module*

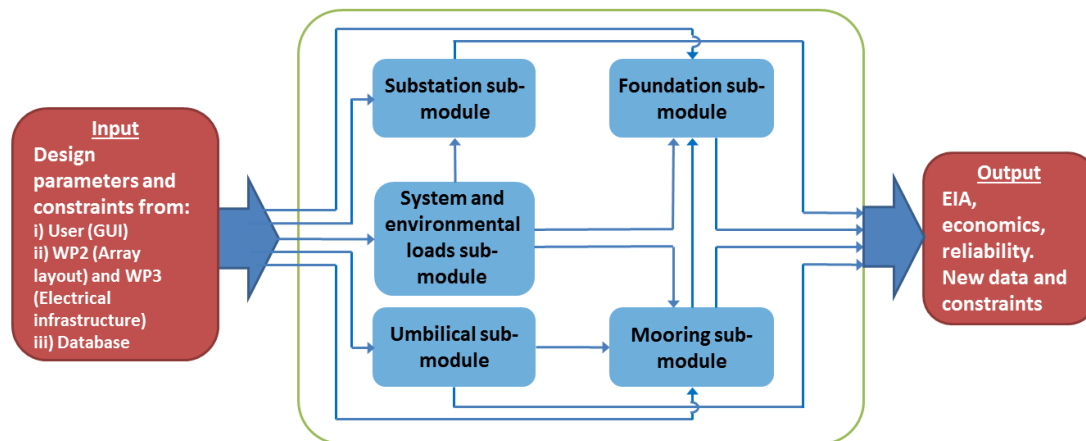

Figure 3: High-level dataflow within the WP4 mooring and foundation module

It can be seen in Figure 3 that all five sub-modules receive input from outside of the WP4 module, (a list of these inputs are provided in Section 2). Output from the sub-modules is sent outside of the WP4 module and these are listed in Section 4. Within the WP4 module the *System and environmental loads sub-module* provides load information to enable design calculations to be performed within the *Substation sub-module*, *Foundation sub-module* and *Mooring sub-module*. The *Mooring sub-module* also receives input from the *Umbilical sub-module*. The *Umbilical sub-module*

¹ The WP6 module will calculate the overall reliability of the system but will need to also identify those critical components with low reliabilities in order to inform the next run of the WP4 module.

does not receive load information from the *System and environmental loads sub-module*, instead loads are applied to the umbilical within the *Mooring sub-module*.

The calculation procedure invoked within the WP4 module will depend on whether the system is floating or fixed. Floating systems require a mooring system and anchors to keep the system on station (see Section 1.3.1). It can be seen in Figure 3 that dataflow occurs between the *Mooring sub-module* and *Foundation sub-module* to allow suitable anchors to be selected. Fixed systems require a foundation to provide a permanent connection between the system support structure and seafloor (see Section 1.3.2). Both fixed and floating systems require an umbilical and the array will require a substation. The type of system is therefore a specific input defined by the user and hence determines which of the sub-modules within the WP4 module will be used.

A working directory (not shown in Appendix A1) will be used to pass information between the sub-modules and temporarily store results.

1.3.1 Floating system

Table 1 lists the processes carried out by the WP4 module for a floating system.

Process	Description	Host sub-module(s)	Target
1	Required parameters provided by the i) user, ii) WP2 and WP3 modules and ii) database via WP7	N/A	All
2	Lazy-wave umbilical geometry defined	Umbilical	Mooring sub-module, Output
3	Environmental and system loads calculated ²	System and environmental loads	Mooring sub-module, Substation sub-module
4	Suitable mooring system configuration sought	Mooring	Foundation sub-module, Output
5	Suitable anchoring system sought	Foundation	Output
6	Suitable substation foundation sought	Substation	Output
7	Configuration hierarchies defined and required output data written	N/A	WP7 core

Table 1: High-level processes for a floating system

² Analysis of time-series to obtain extreme values will not be conducted within the WP4 module. Instead it will be necessary for the user to provide extreme values for each environmental condition (see Section 3.4.2).

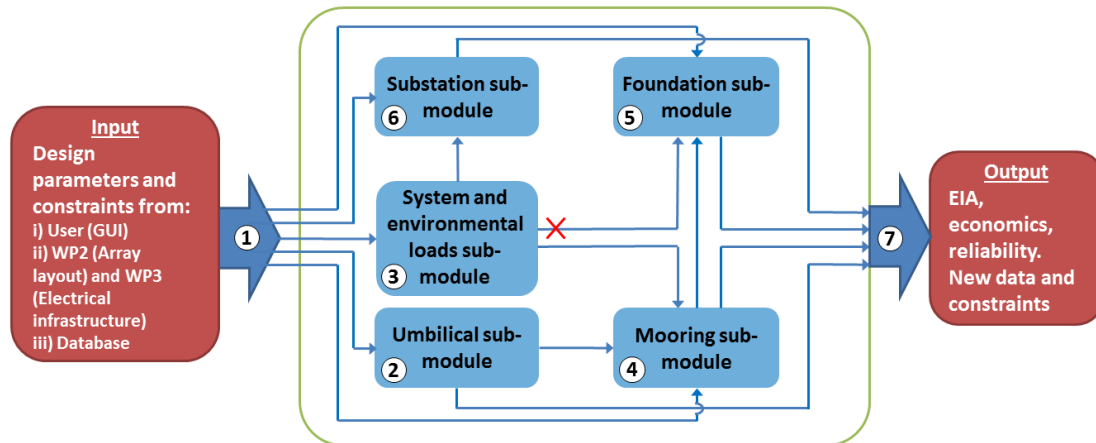

Figure 4: High-level dataflow within the WP4 module for a floating system

1.3.2 Fixed system

Table 2 lists the processes carried out by the WP4 module for a fixed system. It can be seen in Figure 5 that in the case of a fixed system the mooring sub-module is redundant and therefore not used.

Process	Description	Host sub-module(s)	Target
1	Required parameters provided by the i) user, ii) WP2 and WP3 modules and ii) database via WP7	N/A	All
2	Seafloor connection to J-tube umbilical geometry defined	Umbilical	Output
3	Environmental and system loads calculated ³	System and environmental loads	Foundation sub-module, Substation sub-module
4	Suitable foundation system configuration sought	Foundation	Output
5	Suitable substation foundation sought	Substation	Output
6	Configuration hierarchies defined and required output data written	N/A	WP7 core

Table 2: High-level processes for a fixed system

³ See footnote on previous page.

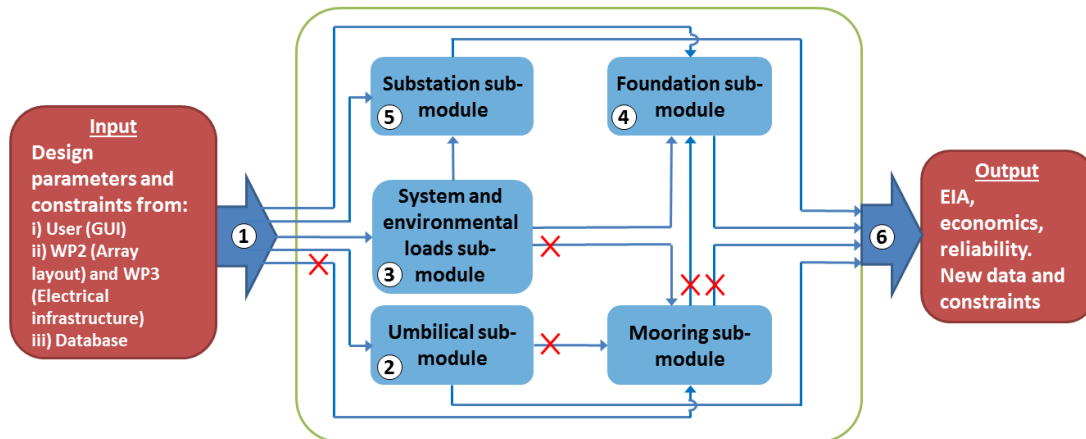

Figure 5: High-level dataflow within the WP4 module for a fixed system

Further detail regarding the calculation processes occurring within each sub-module are provided in Section 3.

2 WP4 MODULE INPUTS

The WP4 module inputs have been split into those which are site- and technology specific. Table 5 and Table 6 list the SI unit, scale type and origin (i.e. user, database or other WPs) of each parameter. The parameters which are shared with other modules are identified by shaded cells and modelling constraints are identified. By definition modelling constraints are those parameters which restrict or limit the free design of mooring or foundation solutions, for example the soil type of the site will preclude particular mooring or foundation types.

The DTOcean Tool will be packaged with a database (DB) populated with data relevant to each module. Whilst the WP4 module will operate based on a minimal amount of ‘default’ data, the user will be able to append their own data thus enabling the database to remain updated with technological advances.

2.1 Data formats

Several different scale types are defined in this section to distinguish between different data types⁴. Nominal parameters such as *soil type* must be specified across the site by the user (e.g. Table 3).

Cohesive (underconsolidated clays)	Cohensionless (noncalcareous, dense)
Cohesive (normally consolidated at depth z)	Cohensionless (noncalcareous, very dense)
Overconsolidated (consistencies: very firm, hard, very hard)	Cohensionless (calcareous)
Cohensionless (noncalcareous, very loose to loose)	Rock
Cohensionless (noncalcareous, medium dense)	

Table 3: An example of a nominal parameter: soil type

Type	Drained (effective) friction angle (deg)	Relative density (%)	Buoyant unit weight (N/m ³)
Very loose to loose	28-30	0-50	45-55
Medium dense	30-36	50-70	55-65
Dense	35-42	70-85	60-70
Very dense	40-45	85-100	60-70

Table 4: Examples of numeric parameters specified as ranges (taken from [1])

Most parameters accessed from the database will be constant values (scale type: ratios). Where linear or non-linear variability of a parameter exists, such as a geotechnical property, the parameter will be specified range (e.g. Table 4). In the absence of suitable empirical relations, look-up tables

⁴ Further information can be found at http://onlinestatbook.com/2/introduction/levels_of_measurement.html

will need to be specified in the database. An example of a non-linear parameter is given in Figure 6 for the design of pile foundations. In this case the coefficient of subgrade soil reaction is specified a function of the maximum lateral deflection criteria (y_{max}/D based on maximum lateral deflection and pile diameter) and relative soil density (D_r). This example would require a three-dimensional look-up table. Because only a finite number of values can be specified in a look-up table an interpolation scheme will have to be built into the module to approximate interim values.

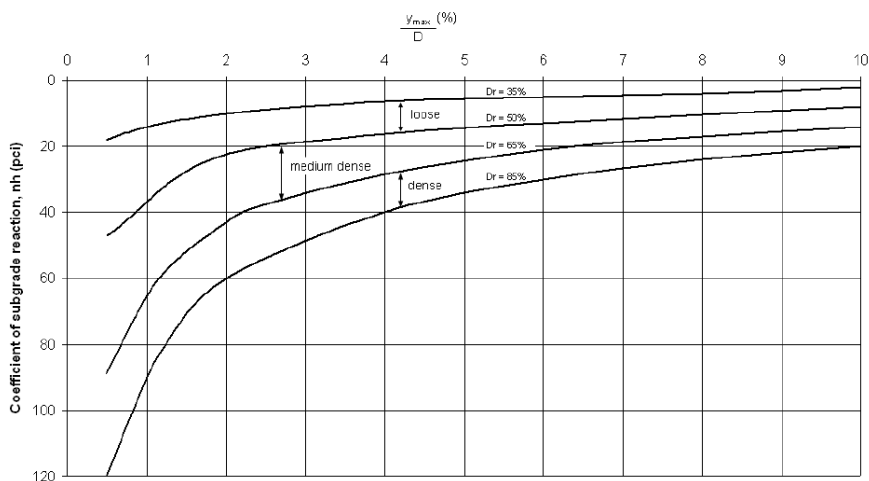

Figure 6: Design values for the coefficient of subgrade soil reaction used in pile design (taken from [1])

2.2 Site specific inputs

The *Foundation sub-module* requires a large number of site-specific inputs which are mainly seafloor geotechnical or geophysical properties. At each grid point, the bathymetry, soil type and soil layers (number and depth) will be defined. A complete list of geotechnical or geological parameters for each grid point would require significant storage space within the database and instead it is proposed that a default set of parameters for each soil type will be stored in the database which can be modified by the user. The proposed hierarchy is illustrated in Figure 7.

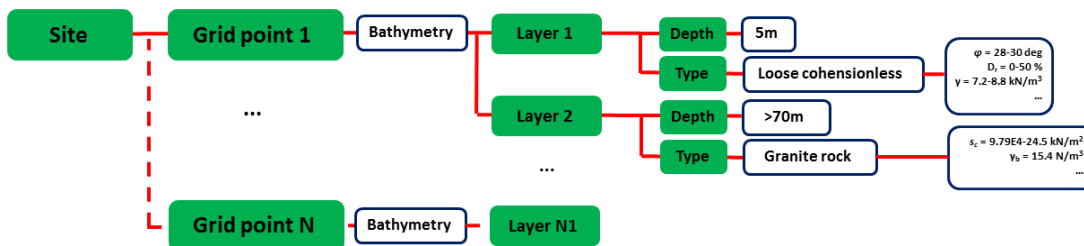

Figure 7: Illustrative data hierarchy at each grid point

Precise data may not be available to the user unless a detailed site survey has been conducted (i.e. at the pre-consent stage only site bathymetry and seafloor surface soil type may be known). At the very least the user will be expected to specify the bathymetry and assumed soil type at each grid point⁵ with the latter accessed via a drop-down menu in the GUI. To ensure that the WP4 module can operate with the minimum possible data soil homogeneity will be assumed if a single soil layer is specified. If a coarse grid is specified then it is likely that complex and spatially dependent seafloor features will be missed (i.e. [2]). Further work is required to determine how spatial variability will be adequately addressed within the WP4 module (i.e. the suitability of assuming uniform properties over the entire or large portions of the domain).

Parameter	SI Unit ⁶	Scale type	Origin					Model constraint?	Comments
			User	DB	WP2	WP3	WP7		
Soil type	N/A	Nominal	X					Yes	e.g. unconsolidated clay
Soil depth and layering	m	Ratio	X					Yes	Identified soil layers at each grid point
Bathymetry	m	Ratio	X					Yes	(x,y,z) using global coordinate system
Water level	m	Ratio	X					Yes	Maximum and minimum water levels
Surface current flow velocity	m/s	Ratio	X					No	Maximum (return period dependent ⁷)
Current flow direction	deg	Ratio	X					No	Associated with max current flow velocity
Significant wave height	m	Ratio	X					No	Maximum (return period dependent)
Peak wave period	s	Ratio	X					No	Associated with significant wave height
Zero up crossing wave period	s	Ratio	X					No	Associated with significant wave height
Spectrum peakedness	ND	Ratio	X					No	To alter JONSWAP spectrum
Predominant wave direction	deg	Ratio	X					No	Associated with significant wave height
Wind gust speed	m/s	Ratio	X					No	Maximum (return period dependent)
Predominant wind direction	deg	Ratio	X					No	Associated with max wind gust speed
Effective drained cohesion	N/m ²	Ratio		X				No	
Undrained soil friction angle	deg	Ratio		X				No	
Drained soil friction angle	deg	Ratio		X				No	
Relative soil density	%	Ratio		X				No	
Buoyant unit weight of soil	N/m ³	Ratio		X				No	
Undrained soil shear strengths	N/m ²	Ratio		X				No	

⁵ A GIS mapping approach could be adopted and if limited site data is available soil types could be inferred from open source data (i.e. http://mapapps2.bgs.ac.uk/geoindex_offshore/home.html)

⁶ ND = non-dimensional

⁷ Further information regarding the appropriate return periods which will be used for water level, wind, current and waves can be found in Section 3.1.1

Parameter	SI Unit	Scale type	Origin					Model constraint?	Comments
			User	DB	WP2	WP3	WP7		
Correction factor subgroups	N/A	Various		X				No	For severe inclination and slopes
Soil friction coefficients	ND	Ratio		X				No	
Shape factor	ND	Ratio		X				No	
Elastic soil shear modulus	N/m ²	Ratio		X				No	
Soil liquid limit	%	Ratio		X				No	
Soil plastic limit	%	Ratio		X				No	
Soil specific gravity	ND	Ratio		X				No	
Soil water content	%	Ratio		X				No	
Compression index	ND	Ratio		X				No	
Over-consolidation ratio	ND	Ratio		X				No	
Bearing capacity factor of buried mooring line	ND	Ratio		X				No	
Pile maximum skin frictional resistance	N/m ²	Ratio		X				Yes	
Pile tip maximum unit soil bearing capacity	N/m ²	Ratio		X				Yes	
Bearing capacity factor limit value	ND	Ratio		X				Yes	
Rock compressive strength	N/m ²	Ratio		X				No	
Pile deflection coefficients	ND	Ratio		X				No	
Pile moment coefficients	ND	Ratio		X				No	
Holding capacity factors	ND	Ratio		X				No	Short- and long-term
Holding capacity factor for drained soil condition	ND	Ratio		X				No	
Anchor soil parameters	ND	Ratio		X				No	Specific to anchors weighing greater than 90kg
Bearing capacity factor (plain strain)	ND	Ratio		X				No	
Adhesion factor	ND	Ratio		X				No	
DSS shear strength	N/m ²	Ratio		X				No	Over depth of penetration
Coefficient of external shaft friction (i.e., steel to soil)	ND	Ratio		X				No	
Coefficient of internal shaft friction (i.e., steel to soil)	ND	Ratio		X				No	
Average undrained soil shear strength over penetrated depth at time t after installation	N/m ²	Ratio		X				No	
Reverse end bearing factor (~9)	ND	Ratio		X				No	
Representative undrained soil shear strength at tip level	N/m ²	Ratio		X				No	
Lateral bearing capacity factor	ND	Ratio		X				No	
Undrained shear strength averaged over penetration depth	m/m ²	Ratio		X				No	

Table 5: Site-specific module inputs

2.3 Technology specific inputs

Technology specific inputs to WP4 are listed in Table 6. These are either supplied by the user or originate from WP2 (array layout) or WP3 (electrical infrastructure).

Parameter	SI Unit	Scale type	Origin					Model constraint?	Comments
			User	DB	WP2	WP3	WP7		
Device ID number	N/A	Nominal					X	No	Identification number of each device
Type of device	N/A	Nominal	X					Yes	e.g. tidal floating
Depth variation permitted	N/A	Nominal	X					Yes	e.g. yes/no
System mass	kg	Ratio	X					No	Includes support structure if relevant
System centre of gravity	m	Ratio	X					No	(x,y,z) w.r.t. system origin
System displaced volume	m ³	Ratio	X					No	Includes support structure if relevant
System height	m	Ratio	X					No	Includes support structure if relevant
Fairlead locations	m	Ratio	X					Yes	(x,y,z) for each fairlead w.r.t. system origin
Prescribed foundation locations	m	Ratio	X					Yes	(x,y,z) for each foundation point w.r.t. system origin
Umbilical connection point	m	Ratio	X					Yes	(x,y,z) w.r.t. system origin
Wet frontal area	m ²	Ratio	X					No	
Dry frontal area	m ²	Ratio	X					No	
Rotor swept area	m ²	Ratio	X					No	
Thrust coefficient	ND	Ratio	X		X			No	
Thrust curve	N(m/s)	Ratio	X		X			No	
Hub height	m	Ratio	X					No	Specified w.r.t. system origin
Orientation angle	deg	Ratio	X					No	Specified w.r.t. grid north
System origin	m	Ratio			X			Yes	(x,y,z) w.r.t. global coordinate system
Drag coefficients	ND	Ratio		X				No	
Structure profile	N/A	Nominal	X					No	e.g. cylindrical, rectangular, elliptical
Inertia coefficients	ND	Ratio		X				No	
First-order wave load RAOs ⁸	F(T)	Ratio			X			No	Wave period-dependent parameter
Radiation damping	B(T)	Ratio			X			No	Wave period-dependent parameter
Added mass	A(T)	Ratio			X			No	Wave period-dependent parameter
Prescribed mooring system	N/A	Nominal	X					Yes	Optional
Maximum displacement amplitudes	N	Ratio	X					Yes	For each mode of motion

⁸ Response amplitude operators

Parameter	SI Unit	Scale type	Origin					Model constraint?	Comments
			User	DB	WP2	WP3	WP7		
Component diameter	m	Ratio		X				No	e.g. chain, rope etc
Component submerged mass per unit length	kg/m	Ratio		X				No	
Component environmental impact	N/A	TBD		X				No	Metric to be determined
Component MBL ⁹	N	Ratio		X				No	
Component axial stiffness	N	Ratio		X				No	Single value used
Component cost	Various	Ratio		X				No	e.g. €/m or €/unit
Required component reliability	Failures/10 ⁶ hours	Ratio					X	Yes	Constraint used after first run of module
Required environmental impact	N/A	TBD					X	Yes	Constraint used after first run of module
Prescribed foundation system	N/A	Nominal	X					Yes	Optional
Cost of steel	€/kg	Ratio		X				Yes	
Cost of grout	€/m ³	Ratio		X				Yes	
Anchor/foundation cost	€/unit	Ratio		X				Yes	
Pile diameter	m	Ratio		X				No	
Pile thickness	m	Ratio		X				No	
Pile stiffness	N.m ²	Ratio		X				No	
Maximum lateral deflection	m	Ratio	X					No	
Grout bond strength	N/m ²	Ratio		X				Yes	
Anchor weight in air	kg	Ratio		X				No	
Small anchor efficiency	ND	Ratio		X				No	
Prescribed umbilical	N/A	Nominal				X		Yes	
Umbilical submerged mass per unit length	kg/m	Ratio		X				No	
Umbilical MBL	N	Ratio		X				No	
Umbilical flexural stiffness	N	Ratio		X				No	
Umbilical minimum bend radius	m	Ratio		X				No	
Umbilical cost per unit length	€/m	Ratio		X				No	
Umbilical environmental impact	N/A	TBD		X				Yes	Metric to be determined
Safety factors	ND	Ratio		X				Yes	For umbilical, foundation and moorings. Various schemes
Prescribed footprint radius	m	Ratio	X					Yes	
Subsea cable connection point	m	Ratio				X		Yes	(x,y,z) w.r.t. global coordinate system
Prescribed substation foundation	N/A	Nominal				X		Yes	e.g. monopile
Substation origin	m	Ratio				X		No	(x,y,z) w.r.t. global coordinate system, includes support structure

⁹ Minimum break load

Parameter	SI Unit	Scale type	Origin					Model constraint?	Comments
			User	DB	WP2	WP3	WP7		
Substation mass	kg	Ratio				X		No	Includes support structure
Substation centre of gravity	m	Ratio				X		No	(x,y,z) w.r.t. substation origin
Substation wet frontal area	m ²	Ratio				X		No	Includes support structure
Substation dry frontal area	m ²	Ratio				X		No	Includes support structure

Table 6: Technology-specific module inputs (parameters shared with other modules are indicated by shading)

3 OVERVIEW OF THE PROPOSED ANALYSIS PROCEDURE

Although the DTOcean tool is a decision tool, each design needs to be assessed in order to make an informed decision. Design principles and formulae for moorings and foundations of marine structures are treated in a wide variety of design standards. These are discussed in the next subsection.

3.1 Design standards

Referring to the module flowchart in the Appendix A1, the analysis procedure will follow the design approaches adopted in widely used guidance documents, including (but not limited to) IEC 62600-10 [3], DNV-OS-E301 [4], DNV-RP-C205 [5], DNV Classification Note 30.4 [6], DNV-OS-J103 [7], DNV-OS-J101 [8], DNV-RP-J301 [9], API-2A-WSD [10], the Handbook for Marine Geotechnical Engineering [1] as well as various published texts (i.e. [11, 12, 13]).

3.1.1 Limit States

The general design approach for a marine structure and its mooring or foundation consists of verification of a number of limit states or failure modes, i.e. a condition beyond which a structure or component no longer satisfies the design requirements. The following limit states are considered in Section 2 of DNV-OS-J101 [8] for offshore wind turbines:

- *Ultimate limit states (ULS)* corresponds to the maximum load-carrying resistance
- *Fatigue limit states (FLS)* corresponds to failure due to the effect of cyclic loading
- *Accidental limit states (ALS)* corresponds to damage to components due to an accidental event or operational failure
- *Serviceability limit states (SLS)* corresponds to tolerance criteria applicable to normal use.

Examples of limit states within each category are:

- *Ultimate limit states (ULS)*
 - 'loss of structural resistance (excessive yielding and buckling)
 - failure of components due to brittle fracture
 - loss of static equilibrium of the structure, or of a part of the structure, considered as a rigid body, e.g. overturning or capsizing
 - failure of critical components of the structure caused by exceeding the ultimate resistance (which in some cases is reduced due to repetitive loading) or the ultimate deformation of the components
 - transformation of the structure into a mechanism (collapse or excessive deformation)'

- *Fatigue limit states (FLS)*
 - ‘cumulative damage due to repeated loads’.
- *Accidental limit states (ALS)*
 - ‘accidental conditions such as structural damage caused by accidental loads and resistance of damaged structures’.
- *Serviceability limit states (SLS)*
 - ‘deflections that may alter the effect of the acting forces
 - deformations that may change the distribution of loads between supported rigid objects and the supporting structure
 - excessive vibrations producing discomfort or affecting non-structural components
 - motions that exceed the limitation of equipment
 - differential settlements of foundations soils causing intolerable tilt of the wind turbine
 - temperature-induced deformations’.

Safety factors are applied on top of the rated strengths or resistances of components (i.e. such as minimum break load; MBL) to provide an adequate margin of safety. In the DNV approach safety factors are specified in the context of safety level (i.e. [8, 7, 14]) or consequence class [4] to reflect the effect of failure (however the latter reference has been developed for the oil and gas industry where the consequence of failure is potentially much greater). Of more relevance to MRE devices are the safety levels specified in DNV-OSS-213 [14]:

- *Safety Level Low* – where failure implies low risk of human injury and minor environmental and economic consequences.
- *Safety Level Normal* – for temporary conditions where failure implies risk of human injury, significant environmental pollution or high economic, asset damage or political consequences. This level normally aims for a risk of less than 10^{-4} per year of a major single accident, which corresponds to a major incident happening on average less than once every 10,000 installation years. This level equates to the experience level from major representative industries and activities.
- *Safety Level High* – for operating conditions where failure implies high risk of human injury, significant environmental pollution or very high economic or political consequences’.

3.1.2 Foundation design

DNV-OS-J101 [8] utilises the partial safety factor method, in which load and resistance factors (i.e. the safety factors) are applied to characteristic values of the governing variables, in order to obtain the design load effect (a function of individual design loads) and design resistance. The governing variables are loads acting on the structure or load effects in the structure and the geotechnical resistance of the surrounding soil or rock. The characteristic values mentioned above are typically chosen as specific quantiles in probability distributions. The safety factors are different for each of the limit states, but generally speaking safety factors applied to loads result in an ‘exaggeration’ of

the applicable loads, while safety factors for resistance 'weaken' the material/components. The Handbook for Marine Geotechnical Engineering [1] proposes a similar approach, however only applying safety factors to the loads (these therefore include the uncertainty on the material/structure properties). If the necessary soil data is accurately known (from in-situ testing or laboratory testing of core samples), a safety factor of 1.5 to 2.0 is recommended¹⁰. If soil properties are not accurately known, a higher safety factor of 2.0 to 3.0 should be used.

A particular aspect for offshore wind turbine foundation design (see Section 10 of DNV-OS-J101 [8]) is that failure due to effect of cyclic loading is treated as an ULS, or alternatively as an ALS, using partial load and material factors as defined for these limit state categories. So no FLS is used for foundation design. This emphasizes the importance of cyclic loading analysis in the design of offshore wind turbines.

The design formulae mentioned in each of these standards are very similar and determine how to calculate or numerically model the interaction between the combined design load effects and design resistance for each of the failure modes.

However, not all standards are clear on how to determine the characteristic values linked to the design loads and design resistance for each of the limit states. For example, the Handbook for Marine Geotechnical Engineering [1] mentions for the design of foundation piles that maximum load or load combinations at the seafloor surface are to be determined from a separate analysis of what is attached to the pile. Sections 4 and 5 of DNV-OS-J101 [8] on the other hand clearly explain the loads, load effects and load and resistance factors used for the design of offshore wind turbine structures and their foundations. Furthermore, formulae are presented that link site conditions to the corresponding loads (additional info can be found in DNV-RP-C205 [5]). Loads are separated into permanent loads (e.g. mass of the structure), variable functional loads (e.g. personnel, ship impacts from service vessels, loads associated with installation operations, etc), environmental loads, abnormal wind turbine loads and deformation loads (e.g. temperature loads, settlements). The environmental loads are further split up in wind loads (and indirect wind loads, e.g. centrifugal force), wave loads, ice loads, water level loads, earthquake loads, marine growth, scour and transportation and installation loads. In reality, combinations of these environmental loads will occur and hence a separate subsection explains how to deal with these situations. For ULS design (similar reasoning for other limit states), the combined load effect whose return period is 50 years (i.e. with associated probability of occurrence of 0.02) is used. Based on DNV-OS-J101 [8] the following three load combinations are proposed to define the characteristic value of the environmental load effect for ULS in an ice-free offshore wind location:

¹⁰ Specified for piles, shallow foundations and gravity anchors.

Wind is characterized by the 10-minute mean wind speed, waves by the significant wave height and peak period, current by the mean current. The 50-year water level is determined as the most unfavourable value of the high water level which is the 98% quantile in the distribution of the annual maximum water level and the low water level corresponding with the 2% quantile. Load calculations may be undertaken by assuming that the wind and the waves are acting co-directionally from a single worst case direction. However, for non-axisymmetric support structures, the most unfavourable wind load direction and wave load direction shall be assumed.

Load Combination	Wind	Waves	Current	Water level
1	50 years	5 years	5 years	50 years
2	5 years	50 years	5 years	50 years
3	5 years	5 years	50 years	50 years

Table 7: Environmental load type and return period to define characteristic value of corresponding load effect (from [8])

It is clear that different loads will apply during power production and the parked configuration. The load effects for load combinations described above should be analysed for both cases. These effects include motions, displacements and internal forces and stresses in the wind turbine structure. Other load combinations apply during transient load cases related to start up from stand-still or from idling, normal shutdown, emergency shutdown, normal fault events (faults in control system and loss of electrical network connection), abnormal fault events (faults in protection system and electrical systems) and yawing.

The information above is mainly based on offshore wind turbines. Particular guidance for tidal turbines is provided in a note by Bureau Veritas: BV Current and Tidal turbines [15], with brief information given for substructures. Similar to the above, again fixed loads, operational loads (forces due to fluid flow around the blade (i.e. pressure and lift and drag forces) and environmental loads are identified. Furthermore, at least following three load cases have to be analysed according to [15]:

- **working condition:** forces due to hydrostatic pressure, forces due to the fluid flow, centrifugal force (these two latter correspond to the maximum rotation speed with the relevant current velocity)
- **extreme condition:** corresponds to the tidal turbine being stopped. Applicable forces are: forces due to hydrostatic pressure, forces due to fluid flow (the latter corresponds to the maximum current velocity of the site).
- **testing condition:** corresponds to the tidal turbine being tested.

Safety factors for drag anchors, anchor piles, plate anchors and gravity anchors are also specified in API RP 2SK [16] and IEC 62600-10 TS Ed.1 [3].

3.1.3 Mooring system design

Various guidance documents exist for the design and certification of offshore mooring systems including DNV-OS-E301 [4], IEC 62600-10 [3], BV NR 493 DT R02 E [17], API RP 2SK [16] and ISO19901-7:2013 [18]. Additionally, DNV-OSS-213 [14] is focused on wave energy converters (WECs) and tidal energy converters (TECs) but in terms of mooring system design the guidance document refers to [4]. The approach to applying combined environmental loads to ensure that the specified mooring system is adequate for the application is broadly the same in [4] and [8] with consequence classes instead of safety levels (Table 8). In addition to wind, wave, current loading, [4] also includes loading due to tides and storm surges, marine growth, earthquakes, temperature, snow and ice.

Load Combination	Wind	Waves	Current
1	100 years	100 years	10 years

Table 8: Environmental load type and return period to define characteristic value of corresponding load effect (from [4]).

The definitions of ULS and ALS in [4] are also similar to those in [8]:

- *Ultimate limit states (ULS)* - ‘...to ensure that the individual mooring lines have adequate strength to withstand the load effects imposed by extreme environmental actions.’
- *Accidental limit states (ALS)* – ‘...to ensure that the mooring system has adequate capacity to withstand the failure of one mooring line,...’

DNV-OS-E301 uses the partial safety factor approach (discussed in more detail in Deliverable 4.3 [19]). The safety factors for quasi-static analysis specified by [4] are listed in Table 9. Lower safety factors are used in ALS because the mooring system is modelled with one less line.

Consequence class	Safety factor	
	ULS	ALS
1	1.70	1.10
2	2.50	1.35

Table 9: Partial safety factors used in ULS and ALS analysis (from [4]).

Referring to Table 10 the safety factors specified by API RP 2SK [16] and IEC 62600-10 TS Ed.1 [3] are notably different to those specified in DNV-OS-E301 for intact (similar to ULS) and damaged (similar to ALS) analysis.

	Intact	Damaged
Tension limit (%MBS)	50	70
Equipment safety factor	2.0	1.43

Table 10: Tension limits and equipment safety factors used in Intact and Damaged state analysis (from [16]).

3.2 Applicability of existing standards to MRE devices and the DTOcean Design Tool

Simplified design approaches will be used within the WP4 module so that the simulations are completed in an acceptable time frame¹¹. A compromise between the run time of the decision tool and the level of solution complexity will therefore be sought. It is important that the applied methodologies should still be sufficiently accurate¹² so that a proper (realistic) decision can be made.

It is easy to understand that the design principle for offshore wind moorings or foundations will also be very similar to those for WECs and TECs. The general approach for tidal turbines will hence be identical to the one for offshore wind turbines. Specifically, it is likely that the effect of tidal currents and waves will be more significant for WECs and TECs than for wind turbines and wind will be less of a matter for the design of the moorings or foundations, unless surface piercing support structures are used (e.g. a substation positioned above the sea surface). This is an important consideration when calculating the design forces and moments at the moorings or foundations, however the design process itself is assumed to be identical.

It appears from the design standards discussed above that the potential failure of the MRE mooring or foundation needs to be checked for several limit states, load combinations and operational conditions. This approach is considered not to be realistic for the DTOcean Tool at present. A number of assumptions will be made in order to restrict the number of load cases to be considered for design. Firstly, only static/quasi-static analysis will be carried out within this project in order not to overload calculations within Version 1 of the DTOcean Tool. It is acknowledged that dynamic/cyclic loading is also important for MRE devices (at least as important as for offshore wind turbines), but this case will not be considered in Version 1 of the Tool. Only load cases for ULS and ALS will be considered, see the *System and environmental loads sub-module* introduced in Section 3.4.2.

Secondly with the exception of pile foundations, the module will not carry out a structural analysis of the foundations or anchors; these components are considered to be rigid. In the first instance the module will therefore only consider the interaction between the foundation or anchor and soil for lateral and axial load analysis.

¹¹ The DTOcean Tool will be designed to run on an off-the-shelf laptop using Windows as an operating system. The target run time of the WP4 module will be in the order of minutes

¹² The required level of accuracy will be defined as the module is further developed

In terms of design formulae for the different types of foundations, the straightforward approach for foundation design mentioned in the Handbook for Marine Geotechnical Engineering [1] will be used for the DTOcean project. It follows an iterative or trial and-error process. The process starts with an estimation of reasonable or “convenient” foundation dimensions, and then an analysis is made to predict performance. If the proposed foundation is found to be inadequate or to be excessively overdesigned¹³, the dimensions are changed and the analysis process is repeated. In some cases the selected foundation for the given soil conditions may be found impractical or too costly. Other foundation types must then be considered. It should be noted that [1] partially does carry out structural analysis, i.e. steel stress analysis for the case of piles. It is also important to note that the applicability of the formulae from [1] that will be used within the DTOcean Tool is limited with regards to seafloor heterogeneity and this will be investigated as part of the validation process of the WP4 module.

Within the WP4 module mooring systems will be designed using a similar limit state approach to that used for foundation design, albeit based on environmental load conditions which have different return periods (i.e. noted if Table 7 and Table 8 are compared). In order to use an approach which is consistent with foundation design, the limit states (ULS and ALS) and return periods specified in DNV-OS-E301 [4] will be adopted (Table 8). In the absence of a return period for water level, the 50 year return period specified in DNV-OS-J101 [8] will be used (Table 11). Full compliance with [4] may not be feasible for the DTOcean Tool, in particular the required separation distance between installations specified in [4] (i.e. a minimum spacing of 50m between accommodation units) could be too restrictive for a MRE device array.

Load Combination	Wind	Waves	Current	Water level
1	100 years	100 years	10 years	50 years

Table 11: Environmental load type and return period to define characteristic value of corresponding load effect (from [4]). Note: the water level return period is taken from [8]

In Sections 3.1.2 and 3.1.3 it was shown that different sets of safety factors exist for mooring and foundation design depending on the issuing certification agency. It is therefore proposed that the user will be able to select a series of safety factors (i.e. API, DNV, IEC etc) based on their preference and/or the requirements of the relevant certification agency.

In Version 1 of the Tool two types of mooring configuration will be implemented; catenary and taut systems. These geometries will be modelled using formulae in well-established texts (i.e. [11, 12]). Subsequent versions of the WP4 module may include variants on these two types, including the use

¹³ Overdesigned: defined as a solution which meets the physical requirements but the capital cost is prohibitively high compared to other solutions.

of floats and clump weights (for an overview of alternative systems, the reader is directed to Deliverable 4.1 [20]).

The proposed analysis procedure based on the assumptions above is presented in Section 3.4 below. The different sub-modules of the WP4 module associated with the design of moorings and foundations of MRE devices are presented using a number of flowcharts. The conventions used for these flowcharts are described in Section 3.3.

3.3 Flowchart conventions

The flowchart comprises blocks to represent processes and boundaries to represent module or sub-module boundaries (Figure 8). Dataflow within the WP4 module is indicated by brown arrows and lines. Lines with a radius indicate a connection or shared dataflow (Figure 9). Crossed lines do not indicate a connection.

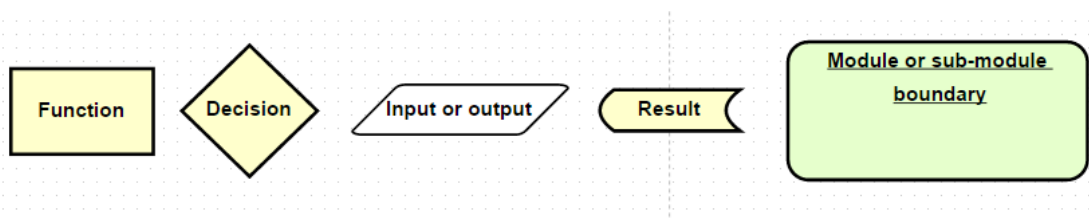

Figure 8: Process blocks and boundaries used in the flowchart

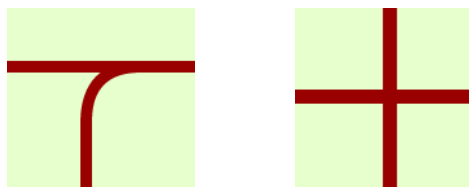

Figure 9: (left) Connection or shared dataflow, (right) no connection or shared dataflow

3.4 Proposed analysis procedure

3.4.1 WP4 module

All calculations performed within the WP4 module will be associated to a *Device ID number* (e.g. *device0001*) which will automatically be assigned by the WP7 core and be utilised by all of the modules within the Tool. The WP4 module will therefore need to have a global loop structure to analyse each device in the array in turn, starting at *device0001* and ending at *device000N*.

Aside from passing information between the sub-modules, the module architecture also contains a decision tree which is used to determine if the device is fixed or floating, based on the device type specified by the user. Section 1.3 provides an overview of the sub-modules used in each case.

3.4.2 System and environmental loads sub-module

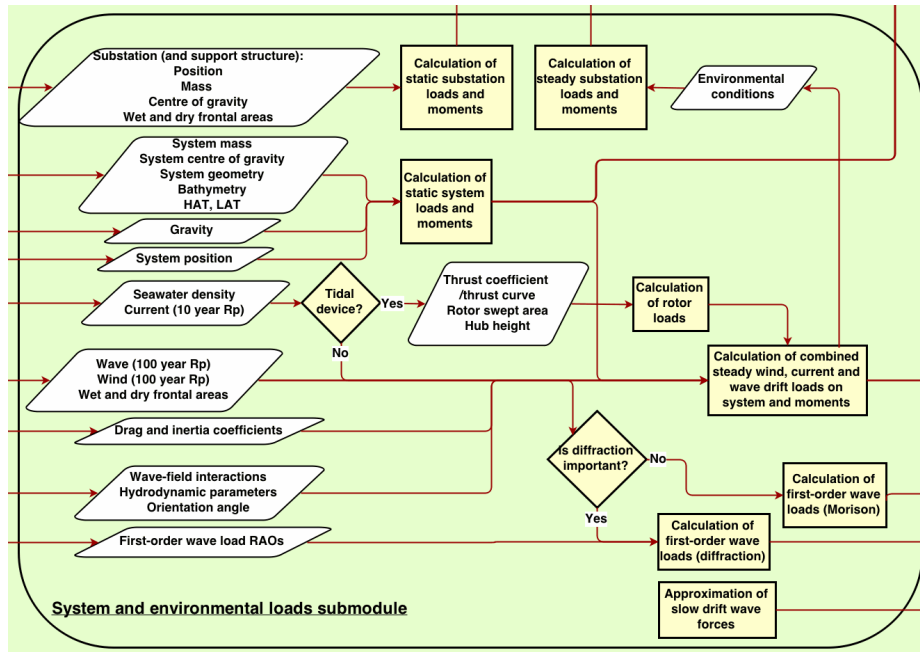

Figure 10: Functions within the System and environmental loads sub-module

Within the *System and environmental loads* sub-module the loads and moments which are experienced by the fixed or floating device are calculated for use by the *Mooring, Foundation and Substation* sub-modules (Figure 10). It should be noted that the device power take-off system will not be explicitly modelled in the WP4 module but may be included in later versions of the Tool.

The global position of the device (from WP2), site parameters (i.e. bathymetry and tidal range) in addition to the system properties (i.e. mass, centre of gravity and geometry) as specified by the user will be utilised to determine the static loads experienced by the device, such as gravity and buoyancy (for floating devices) or eccentric loading. These results are utilised by the *Mooring* and *Foundation* sub-modules. For the *Substation sub-module* the same calculation is carried out, with substation information provided by WP3.

Calculation of the design loads is expected to be carried out according to the general methodology outlined in [4] and [8]. If the device is a tidal turbine, the thrust experienced by the support structure will be estimated based on the prescribed surface current (based on the return periods listed in Table 7), the rotor swept area, hub height and either a thrust coefficient or the maximum value of the user-supplied thrust curve. By default a 1/7 power law depth distribution will be used. This may, however not be applicable for all sites, and the ability to specify a depth-dependent profile may be included in a later development version of the Tool. This result will contribute to the calculation of steady loads on the system.

The calculated static loads are utilised by the *Calculation of combined steady wind, current and wave drift loads on system and moments* function. In this function, the specified wind and wave conditions¹⁴ in addition to current (with return periods defined in Table 7 and Table 8) are used to estimate the steady loads on the system. These calculations utilise drag and inertia coefficients stored in the database¹⁵ as well as the user-specified wet and dry frontal areas. For floating devices, first-order wave load RAOs (as calculated by WP2) will be used to estimate mean drift loads.

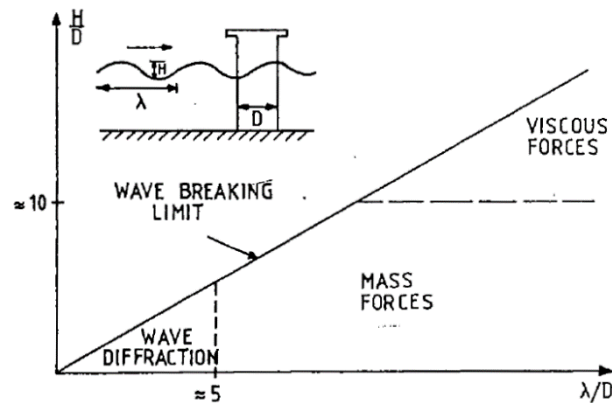

Figure 11: The relationship between wave parameters, structure size and wave forces (taken from [11])

The next stage is the *Calculation of first-order wave loads* function, which for floating devices, will be used by the *Mooring sub-module* to estimate oscillations of the device about the mean offset position. The approach used to calculate wave loads on the device or structure will depend on whether diffraction is important, which will be judged by the size of the structure in relation to the incident wave parameters and water depth at the device location (e.g. Figure 11). If diffraction should be considered, hydrodynamic parameters calculated by WP2, including added mass, radiation damping and first-order wave load RAOs will be used. If the diffraction regime is not relevant, wave loads on the structure are estimated using the Morison equation and the aforementioned drag and inertia coefficients.

Slow drift wave forces will also be estimated, probably using the approach given in Chakrabarti [12].

¹⁴ Wave load combinations of significant wave height, wave period (peak or zero up-crossing) and direction along the relevant return period contour will be considered, necessitating several iterations of this function.

¹⁵ Drag and inertia coefficients for common geometries will be stored in the database. It will be up to the user to select which geometry most closely matches the device in question (e.g. a fixed tidal turbine structure could crudely be represented by cylindrical members).

3.4.3 Umbilical sub-module

A flowchart showing the main functions of the *Umbilical sub-module* is provided in Figure 12. Based on the location of the subsea cable (as specified by WP3) and required umbilical properties and the bathymetry of the site (retrieved from the database) the umbilical geometry will be defined. The equilibrium geometry of the umbilical will be determined iteratively. Two options are available depending on whether the device is fixed (a 'hang-off'-type geometry from the subsea cable up to the J-tube) [9] or floating ('Lazy-wave' geometry) [21].

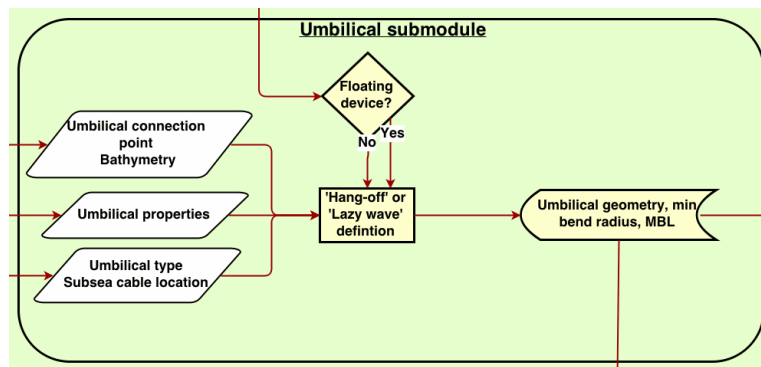

Figure 12: Functions within the Umbilical sub-module

The calculated length of the umbilical will then be sent to WP3 (via the WP7 core) to determine its capital cost and any power losses. The calculated geometry and umbilical constraints (minimum break load and minimum bend radius) will be used by the *Mooring Foundation* sub-modules.

3.4.4 Mooring sub-module

If the device is floating, mooring systems with anchors will be considered. The user may have a particular mooring system type in mind, perhaps from laboratory experiments or field trials of a single device. If a type has been specified by the user, the *Mooring type decision tree* will be skipped.

If the location of the anchors or a maximum footprint radius has been specified by the user then these values will be used in the definition of the mooring system geometry. Alternatively an anchor radius will be set by the *Mooring sub-module* using a relationship between the mooring line length and water depth (i.e. Fitzgerald et al. considered mooring line lengths ranging from 3-8x the water depth in [22]), based on the supplied site bathymetry as well as maximum and minimum water level values.

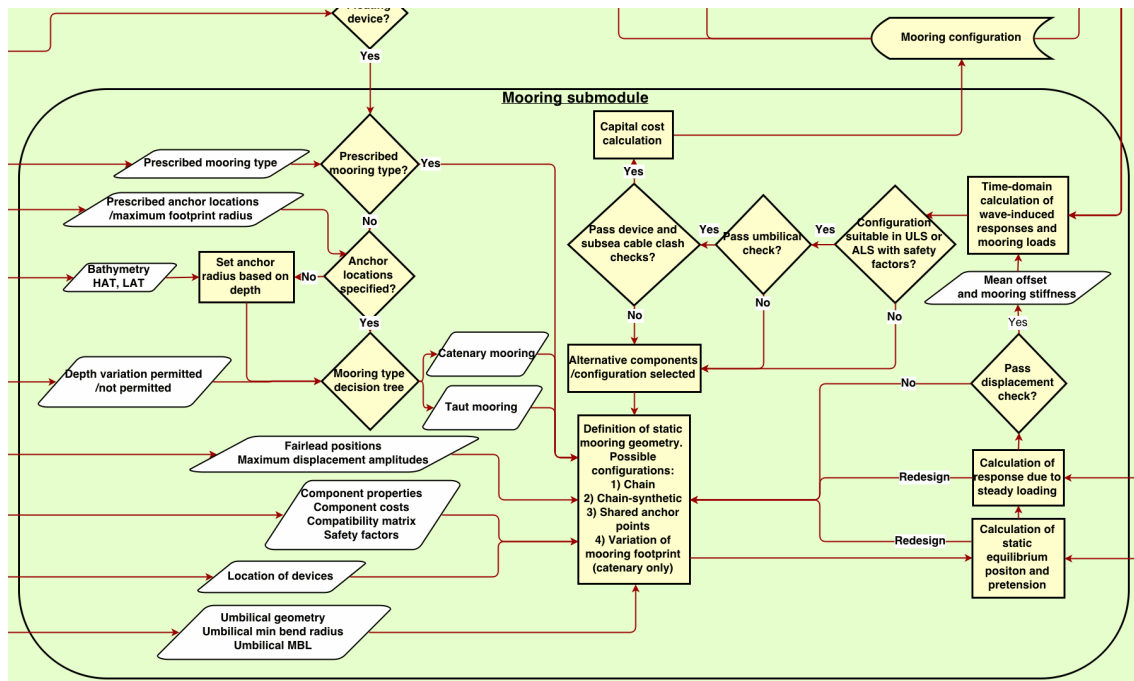

Figure 13: Functions within the Mooring sub-module

The *Mooring type decision tree* will determine if a catenary or taut moored system is most suitable for the application, based on the maximum tidal range of the site and whether the device must remain at the same specified level in the water column¹⁶ throughout all states of tide.

The *Definition of static mooring geometry* will first consider a mooring system comprising chain only using the user-supplied fairlead locations. The umbilical will be included in the analysis as an additional line. Other configurations which could¹⁷ be considered in this optimisation loop include i) chain-synthetic rope, ii) shared anchor points between devices and iii) reduction of the ground chain length (for catenary systems only). The selection of components which make up each configuration will be based on connecting sizes accessed from the database (i.e. mooring hardware is typically manufactured in common sizes, see example in Appendix A3). This will prevent incompatible components from being selected.

The first calculation step will be to determine the *Static equilibrium and pretension* using the static system loads calculated in the *System and environmental loads sub-module*. If a fixed equilibrium position has been specified (see *Mooring type decision tree*) and this position is not achievable, then the configuration will have to be modified in the *Definition of static mooring geometry* block (i.e.

¹⁶ Defined by the *Device origin* variable

¹⁷ This list may be subject to change as the Tool is further developed.

altering the line weight to change the mooring system pretension). For a catenary system, an iterative loop will be included in the function to achieve equilibrium between the tension and fairlead position of all lines in the system.

Once static equilibrium has been achieved, the *Response due to steady loading* will be calculated based on the steady wind, current and mean drift loads calculated in the *System and environmental loads sub-module*. A check will be made to ensure that the calculated horizontal offset (surge/sway) is within the maximum displacement amplitude limits set by the user and compatible with the specified array layout. Again if the configuration is unsuitable, alternative components will be sought from the database in the *Definition of static mooring geometry* function. For catenary systems the equilibrium condition will have to be found iteratively within this function.

The resulting mean offset of the device and mooring stiffness will then be utilised in the *Time domain calculation of wave-induced responses and mooring loads* function. This simple calculation will not consider the dynamic behaviour of the mooring lines and therefore not be a fully coupled dynamic calculation. Instead it will be used to approximate the limits of motion and mooring tensions due to first-order wave excitation and second-order wave drift forces. Three criteria will be used to determine the suitability of the mooring configuration:

- The mooring system must be adequate in both Ultimate Limit State (mooring system intact) and Accident Limit State (one line removed) with relevant safety factors applied [4].
- Loads on the umbilical must be within acceptable limits and the minimum bend radius must not be exceeded along the length of the umbilical.
- A check is made to ensure that the maximum displacement regions of the device are within the user-defined displacement amplitude limits and that neighbouring devices do not coincide. This check will not have to be carried out for every device if the devices are equispaced within the array layout. A check will also be made to ensure that the mooring lines and subsea cables do not coincide¹⁸.

An iterative scheme will be devised to specify alternative mooring components if the mooring configuration fails any of these checks. The number of iterations in this loop will have to be limited because potentially for a given configuration no practical solution exists. If the limit is exceeded, a different type of configuration will be considered instead. There is hence scope to optimise the functions within this sub-module.

Once a set of suitable mooring systems have been identified the capital cost of each configuration will be calculated and the configuration with the lowest cost will be output from WP4 module.

¹⁸ This check may be conducted externally by the WP7 core

3.4.5 Foundation sub-module

If the device is fixed, foundations instead of anchors will be considered. Alternatively the user may have a particular foundation type in mind in order for the foundation to be compatible with the support structure. If particular types have been specified by the user, the *Foundation type decision tree* will be skipped. For a fixed system it will be necessary for the user to specify the location of the foundation points with respect to the local system origin.

The *Foundation type decision tree* will query site information (i.e. bathymetry, soil type, soil depth and layering) specified by the user as well as accessing the database of foundation and anchor components to determine the most suitable range of foundation or anchor technologies. The decision tree will comprise a number of matrices (see examples given in Appendix A2), such as the *Soil matrix*. The *Soil matrix* will be used to determine the suitability of the available foundation options for particular soil types, with a score assigned to each option. Utilising the definitions given in [1] the scores could relate to '1=functions well, 2=normally not the preferred choice, 3=does not perform well'. The foundation type with lowest score would be considered to be the most feasible.

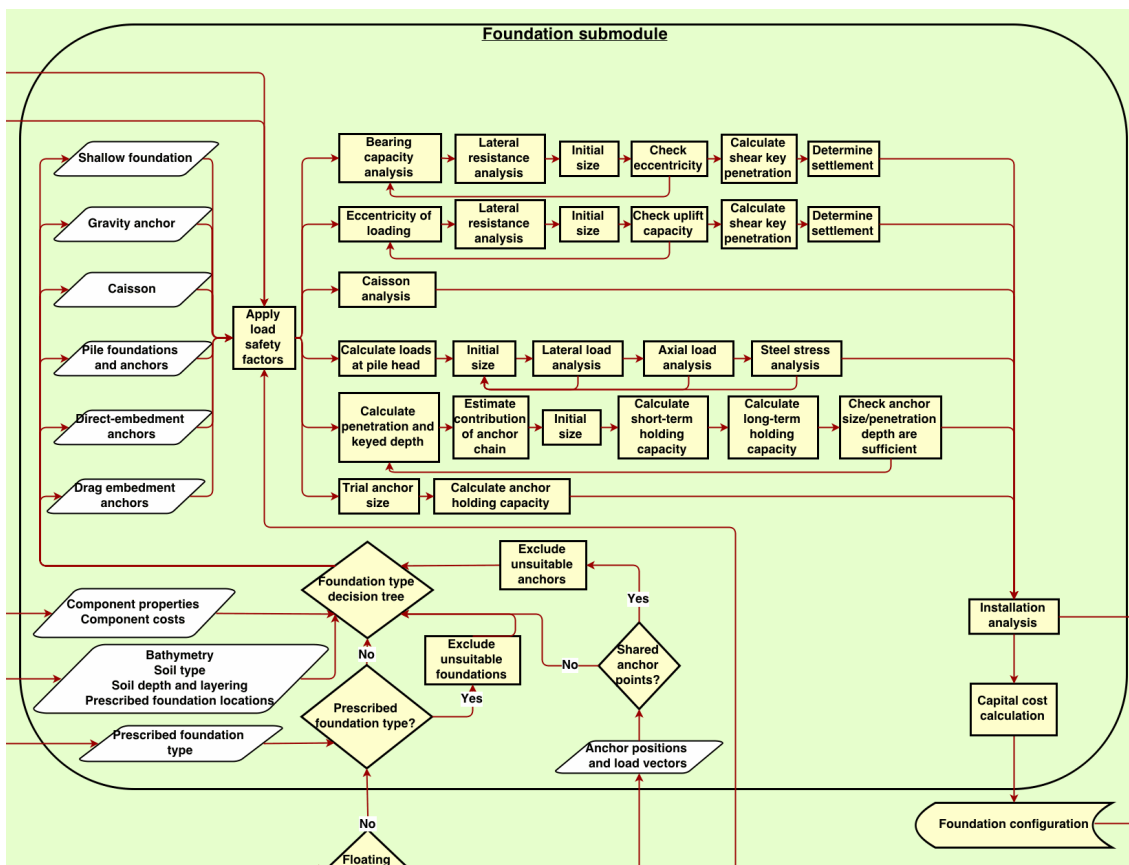

Figure 14: Functions within the Foundation sub-module

In the case of a moored device, anchor positions and load vectors will be used to determine suitable anchoring systems¹⁹, which will be determined based on soil type, soil depth and layering in addition to load direction (with the latter originating from the *Mooring sub-module*). If shared anchoring points are deemed to be feasible by the *Mooring sub-module* then this will also limit the selection of anchor types to those which can be compatible with multi-directional loads. For fixed structures, soil type (including depth and layering) will be the main deciding factor. Soil heterogeneity across the site could result in several different foundation or anchor solutions. For an array of devices a large selection of foundation or anchor types will not be practicable nor economically viable, and hence the free selection will probably have to be constrained, particularly for large footprint, spread mooring systems.

Each foundation type will have its own calculation procedure, as indicated in Figure 14. Most approaches involve first determining the applied loads, applying safety factors and then based on the supplied soil parameters, the size and/or penetration depth of the foundation are adjusted iteratively to suit the application. This process could be optimised. Basic structural (stress) analysis will only be conducted for pile foundations.

Any calculations associated with installation requirements will then be performed to inform logistical operations planning conducted by the WP5 module.

Once a set of suitable foundation systems have been identified the capital cost of each configuration will be calculated and the configuration with the lowest cost will be output from the WP4 module.

3.4.6 Substation sub-module

This will operate in a similar way to the *Foundation sub-module*, albeit it will consider only pile foundations (i.e. monopiles for above-water substations and pin piles for substations mounted directly on the seafloor). The location and features of the substation will be determined by the WP3 module, with static loads calculated within the *System and environmental loads sub-module*. Once a set of suitable foundation systems have been identified the capital cost of each configuration will be calculated and the configuration with the lowest cost will be output from the WP4 module.

¹⁹ In Section 3.1 it was shown that different approaches exist for mooring and foundation design. For moored devices, the analysis of anchors within the *Foundation sub-module* will therefore be conducted using mooring-specific certification approaches (i.e. [4]).

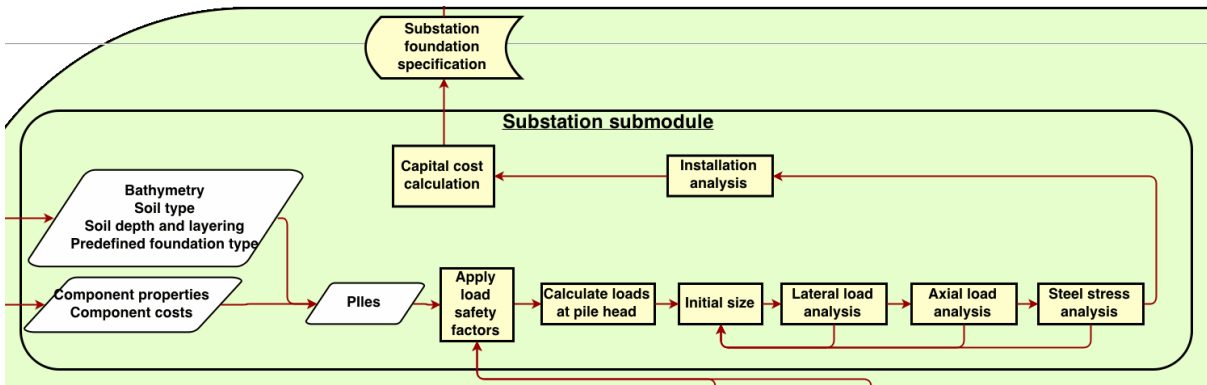

Figure 15: Functions within the Substation sub-module

Any calculations associated with installation requirements will then be performed to inform installation planning within the WP5 module.

4 WP4 MODULE OUTPUTS

The WP4 module outputs are listed in this section, including the SI unit, format and destination of each parameter.

Parameter	SI Unit	Scale type	Output Class	Destination				Comments
				WP3	WP5	WP6	WP7	
Device ID number	N/A	Nominal					X	Identification number of each device
Configuration list	N/A	Nominal	Economics				X	Lowest capital cost solution
Configuration category	N/A				X			e.g. taut-moored, gravity base structure
Configuration hierarchy	N/A	Nominal	Reliability			X		Structure comprising component ID numbers
Configuration volume	m	Ratio (x,y,z)	Environmental				X	Used for environmental impact assessment. Occupying volume specified by co-ordinates
Configuration size	m	Ratio (x,y,z) principal dimensions			X			For fixed structures this will be the same as 'Configuration volume'
Configuration dry mass	kg	Ratio			X			
Configuration wet mass	kg	Ratio			X			
Umbilical length	m	Ratio		X				Used by WP3 to calculate transmitted power
Component quantity	N/A	Ratio	Economics and reliability		X	X		
Component size	m	Ratio (x,y,z) principal dimensions			X			
Configuration bill of materials	Various	Various	Economics				X	Bill of materials listing the overall configuration cost with a breakdown of all component names, component quantities and prices
Configuration environmental impact	N/A	TBD	Environmental				X	Metric to be determined
Maximum fairlead loads	N	Ratio					X	For log file
Maximum anchor loads	N	Ratio					X	For log file
Maximum structure loads	N	Ratio					X	For log file
Maximum structure moments	Nm	Ratio					X	For log file
Maximum device displacements (translational)	m	Ratio					X	deltax, deltay, deltaz for log file
Maximum device displacements (rotational)	deg	Ratio					X	deltaroll, deltapitch, deltayaw for log file
Key seafloor parameters and bathymetry at installation locations	Various	N/A			X			Key parameters to include: soil types, maximum and minimum water depths, layering

Parameter	SI Unit	Format	Output Class	Destination				Comments
				WP3	WP5	WP6	WP7	
Foundation/anchor installation depth	m	Ratio			X			e.g. for pile driving
Maximum foundation lowering rate	m/s	Ratio			X			Installation limit
Foundation installation force	N	Ratio			X			For piles
Necessary under-pressure	Pa	Numeric			X			For suction caisson foundations or anchors
Vertical pull-out resistance (ultimate vertical bearing capacity)	N	Ratio			X			For suction caisson foundations or anchors
Maximum horizontal resistance	N	Ratio			X			For suction caisson foundations or anchors
Required anchor installation load	N	Ratio			X			
Required installation time	s	Ratio			X			e.g. interval during which installation load must be applied to anchor or grout curing time

Table 12: WP4 module outputs

The two main outputs from the WP4 module will be the *Configuration hierarchy* and the *Configuration bill of materials*. The *Configuration hierarchy* will be used by the WP5 module to plan logistics (i.e. to determine the order of component or sub-system installation) and the WP6 module to assess system reliability. The *Configuration bill of materials* will provide the user with a list of all of the components defined by the WP4 module as well as component quantity, unit cost and total price. This list will be based on the capital cost calculation carried out by each sub-module. A possible approach for defining the *Configuration hierarchy* is provided in Appendix A4.

Additional information in the form of a log file could also be outputted from the WP4 module, describing maximum loads, moments and displacements from the static and quasi-static analysis.

5 CONCLUSIONS

The main aim of the Tool will be to provide an initial assessment of several aspects of MRE array design. The role of the WP4 module within the Tool will be to generate suitable mooring and foundation solutions based on information originating from several sources; the user, the other design modules as well as drawing from the built-in database. It is acknowledged that in order to rapidly produce suitable mooring and foundation solutions a compromise between analysis complexity and calculation time will be required within the module. Simplified design approaches utilising linear and non-linear input parameters from referenced sources will be used for this task. The module is not intended to replace existing mooring system or geotechnical software, but instead provide a preliminary assessment to determine a solution which is both technically and logistically feasible. The assessment conducted by the WP4 module will enable the user to focus on a suitable design and conduct subsequent analysis using software of their choice.

Within this Deliverable report the proposed functions of WP4 mooring and foundation module have been defined within the context of the DTOcean Tool. A high-level summary of the proposed module has been provided in this report indicating the expected interaction of the module with the other Tool modules, user and database via the WP7 core. The first run of the Tool will most likely be sequential, starting at WP2 (array layout), followed by WP3 (electrical infrastructure), then WP4 and finally WP5 (lifecycle logistics) and WP6 (system control and operation). Subsequent runs of the Tool will include feedback from WP5 or WP6 with regard to logistics or reliability in the form of constraints which will channel the design of the mooring or foundation towards an optimum solution. Having defined the WP4 module framework, the next stage will be to develop a 'black box' version of the module for integration with the other Tool modules including definition of the relevant feedback mechanisms.

6 BIBLIOGRAPHY

- [1] D. Thompson and D. J. Beasley, Handbook for Marine Geotechnical Engineering: SP-2209-OCN, Books Express Publishing, 2012.
- [2] J. V. Barrie and K. W. Conway, "Seabed characterization for the development of marine renewable energy on the Pacific margin of Canada," *Continental Shelf Research*, vol. 83, pp. 45-52, 2013.
- [3] International Electrotechnical Commission, "IEC 62600-10 TS Ed.1: Marine energy - Wave, tidal and other water current converters - Part 10: Assessment of mooring system for Marine Energy Converters (MECs)," 2014.
- [4] Det Norske Veritas, "Position Mooring: DNV-OS-E301," 2013.
- [5] Det Norske Veritas, "Environmental Conditions and Environmental Loads: DNV-RP-C205," 2010.
- [6] Det Norske Veritas, "Foundations. Classification Notes No. 30.4," 1992.
- [7] Det Norske Veritas, "Design of Floating Wind Turbine Structures. DNV-OS-J103," 2013.
- [8] Det Norske Veritas, "Design of Offshore Wind Turbine Structures. DNV-OS-J101," 2011.
- [9] Det Norske Veritas, "Subsea Power Cables in Shallow Water Renewable Energy Applications," 2014.
- [10] American Petroleum Institute, "Planning, Designing and Constructing Fixed Offshore Platforms - Working Stress Design. API-2A-WSD," 2010.
- [11] O. M. Faltinsen, Sea loads on ships and offshore structures, Cambridge University Press, 1990.
- [12] S. Chakrabarti, Handbook of Offshore Engineering, Oxford, United Kingdom: Elsevier, 2005.
- [13] E. T. R. Dean, Offshore geotechnical engineering. Principals and practice, London, UK: Thomas Telford Limited, 2010.
- [14] Det Norske Veritas, "Certification of Tidal and Wave Energy Converters," 2008.

- [15] Bureau Veritas, "Current and Tidal Turbines, Rule Note, NI 603 DT R00 E," 2013.
- [16] American Petroleum Institute, "Recommended Practice for Design and Analysis of Stationkeeping Systems for Floating Structures. API RP 2SK," 1996.
- [17] Bureau Veritas, "Classification of Mooring Systems for Permanent Offshore Units. NR 493 DT R02 E," 2012.
- [18] International Standards Organisation, "Petroleum and natural gas industries -- Specific requirements for offshore structures -- Part 7: Stationkeeping systems for floating offshore structures and mobile offshore units: ISO19901-7:2013," 2013.
- [19] DTOcean, "Deliverable 4.3 – Report on suitability of assessment functions to validate novel mooring and foundation component designs," 2014.
- [20] DTOcean, "Deliverable 4.1 - A comprehensive assessment of the applicability of available and proposed offshore mooring and foundation technologies and design tools for array applications," 2014.
- [21] W. Ruan, Y. Bai and P. Cheng, "Static analysis of deepwater lazy-wave umbilical on elastic seabed," *Ocean Engineering*, vol. 91, pp. 73-83, 2014.
- [22] J. Fitzgerald and L. Bergdahl, "Considering Mooring Cables for Offshore Wave Energy Converters," in *Proceedings of the 7th European Wave and Tidal Energy Conference*, Porto, Portugal, 2007.

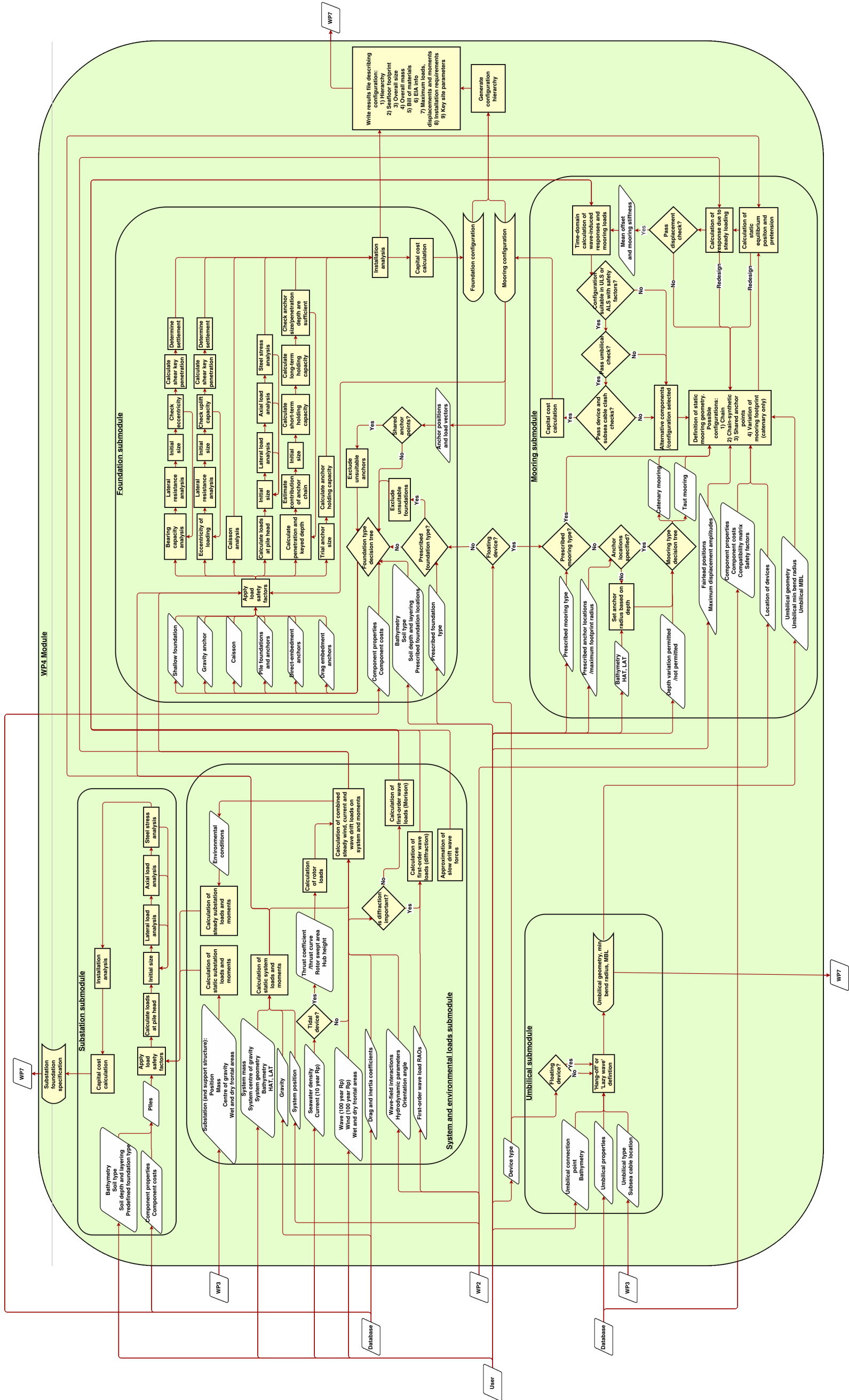

8 APPENDIX A2 - PROPOSED FOUNDATION SUB-MODULE DECISION MATRIX

Below is a proposed approach to determining the suitable range of foundations for analysis within the *Foundation sub-module* adapted from [1]. Separate matrices are presented for soil type, seafloor topography, soil depth, loading direction and magnitude²⁰; this could be implemented in the Tool database as a single look-up table.

Soil type	Shallow	Gravity	Pile	Suction caisson	Direct embedment	Drag
Soft clay, mud	1	1	2	1	1	1
Stiff clay	1	1	1	1	1	1
Sand	1	1	1	1	1	1
Hard glacial till	2	1	1	3	1	2
Boulders	3	1	3	3	3	3
Soft rock or coral	3	1	1	3	1	3
Hard, monolithic rock	3	1	2	3	3	3

Table 13: Soil matrix listing the performance of foundation and anchor types as a function of seafloor conditions

Seafloor topography	Shallow	Gravity	Pile	Suction caisson	Direct embedment	Drag
Moderate slopes < 10 deg	1	1	1	1	1	1
Steep slopes > 10 deg	3	3	1	2	2	3

Table 14: Topography matrix

Soil depth	Shallow	Gravity	Pile	Suction caisson	Direct embedment	Drag embedment	
						Dense sand	Soft clay/silt
None	3	1	1	3	3	3	3
0 m < Very shallow < 1 m	1	1	1	3	3	3	3
1 m ≤ Shallow < 6 m	1	1	1	2	3	2	3
6 m ≤ Moderate < 25 m	1	1	1	1	1	1	2
Deep ≥ 25 m	1	1	1	1	1	1	1

Table 15: Sensitivity to soil depth matrix

Loading direction	Shallow	Gravity	Pile	Suction caisson	Direct embedment	Drag
Downward load component (foundations)	1	1	1	1	3	3
Omni-directional (not down)	1	1	1	1	1	3
Uni-directional (not down)	1	1	1	1	1	1
Large uplift component	3	1	1	1	1	3

Table 16: Load direction matrix

Load magnitude	Shallow	Gravity	Pile	Suction caisson	Direct embedment	Drag
$L < 444.8$ kN	1	1	2	2	1	1
444.8 kN ≤ L ≤ 4448.2 kN	2	2	1	1	2	1
$L > 4448.2$ kN	3	3	1	1	3	3

²⁰ These scores are illustrative and may be subject to change. In addition multiple load directions may be possible. The required penetration depth of direct- and drag embedment anchors is typically technology dependent.

Table 17: Load magnitude matrix

The approach to determining foundation suitability is based on a simple sum of each parameter, with the lowest score deemed to be the most suitable for the site. Weighting could be applied to each parameter.

Example 1:

A foundation is required for a fixed TEC (deadweight load: 1470kN) at site with steep sloping, deep soft clay:

- Pile = $2+1+1+1+1 = 6$
- Suction caisson = $1+2+1+1+1 = 6$
- Shallow = $1+3+1+1+2 = 8$
- Gravity = $1+3+1+1+2 = 8$

Therefore in the first instance pile or suction caisson designs would be explored.

Example 2:

An anchor is required for a taut-moored WEC (tensile loads up to 100kN) at a hard rock site with a fairly flat profile:

- Gravity = $1+1+1+1+1 = 5$
- Pile = $2+1+1+1+2 = 7$
- Direct embedment = $3+1+3+1+1 = 9$
- Suction caisson = $3+1+3+1+2 = 10$
- Drag = $3+1+3+3+1 = 11$
- Shallow = $3+1+3+3+1 = 11$

Therefore gravity anchors would be prioritised initially.

Of course in both examples a practicable design may not be achievable in which case the technology with the second lowest score would be selected.

9 APPENDIX A3 – POSSIBLE COMPONENT SELECTION PROCEDURE

Component selection will take place in the *Umbilical, Mooring and Foundation sub-modules* based on input and constraints sent to the WP4 module. The Tool database will use PostgreSQL and this appendix presents one possible way for the WP4 module to access it. As an example a drag embedment anchor is required from the database with a holding capacity of 20.4 Tonnes for connection with a 30 mm forerunner assembly at a sand site.

Capacity.py

```
""" Determine which anchors in the database have a holding capacity over a
specified value and compatible connector size."""

from calculate import size
import pprint
""" Required holding capacity, connector size and soil type (sand or mud)
"""
size_an = size(20.4, 30, "sand")
pprint.pprint(size_an)
```

Calculate.py

```
""" Determine which anchors in the database have a holding capacity over a
specified value and compatible connector size."""

import psycopg2

def size(HCreq, consize, soil):

    """ Connect to anchor database """
    conn_string = "host='localhost' dbname='foundation' user='sw'
password='123'"
    conn = psycopg2.connect(conn_string)
    cursor = conn.cursor()
    """ Retrieve all anchors """
    cursor.execute("""SELECT * from anchors WHERE type = 'draganc'""")
    rows = cursor.fetchall()
    """ Retrieve column names for reference """
    field_names = [i[0] for i in cursor.description]

    """ Required connecting size for anchor shackle """
    RS = [i[11] for i in rows]
    """ Calculate holding capacity of anchors """
    if soil == "sand":
        HC = [i[4]*i[3]**i[6] for i in rows]
    elif soil == "mud":
```

```
        HC = [i[5]*i[3]**i[7] for i in rows]
    else:
        return "Soil type not included"

    """ Select anchors which meeting holding capacity and connector size
    requirement """
    int_anc = []
    sel_anc = []
    for index in range(len(HC)):
        if (HC[index] > HCreq and RS[index] == consize):
            int_anc.append(index)
            sel_anc.append([index, i[1], HC[index]])
    """ Return database integer, component ID and calculated holding
    capacity """
    return sel_anc

if __name__ == "__size__":
    size()
```

10 **APPENDIX A4 - POSSIBLE WP4 MODULE OUTPUTS**

For the example given in Figure 16, parameter names have been assigned in Table 18.

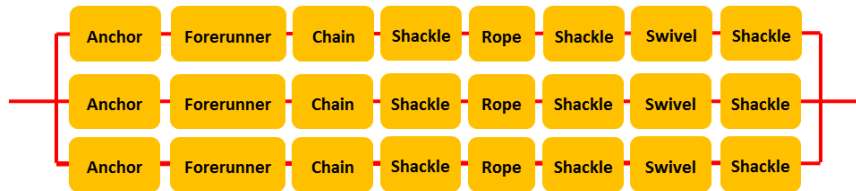

Figure 16: Example mooring configuration comprising identical components in each of the three mooring lines

Component description	Parameter Name
Danforth anchor 1.1 Tonne	andarn_1p1T
Forerunner assembly	frunner_DN32
Studlink chain DN32	slchn_DN32
Shackle WLL 9.5 Tonne	shkl_9p5T
Nylon rope D44	nyrope_D44
Shackle WLL 9.5 Tonne	shkl_9p5T
Swivel shackle D32	swshkl_D32
Shackle WLL 9.5 Tonne	shkl_9p5T

Table 18: Parameter names for the example shown in Figure 16

One possible approach to representing the *Configuration hierarchy* in Python could be the use of nested lists:

```

"""Construct component list"""
child_list =
["andarn_1p1T", "frunner_DN32", "slchn_DN32", "shkl_9p5T", "nyrope_D44", "shkl_9
p5T", "swshkl_D32", "shkl_9p5T"]

"""Construct subsystem list"""
parent_list = [child_list, child_list, child_list]
print parent_list

```

The *Configuration bill of materials* will utilise the capital cost calculation which will be carried out in the *Mooring, Foundation and Substation sub-modules*. To construct the *Configuration bill of materials* the number of instances of each component in the configuration of each device will be counted:

```
"""Merge subassembly list"""
merged = sum(parent_list, [])

"""Determine total component quantities in subsystem"""
from collections import Counter
Counter(merged)
print merged
```

By retrieving the cost information for each component, the quantity of each component can be used to calculate the total capital cost of each configuration.