

Running head: EFFORT DISRUPTS IMPLICIT AGENCY

Physical and mental effort disrupts the implicit sense of agency

Emma E. Howard, S. Gareth Edwards & Andrew P. Bayliss

University of East Anglia

#### **Author Note**

Emma E. Howard, S. Gareth Edwards and Andrew P. Bayliss, School of Psychology, University of East Anglia.

EEH and APB conceived the idea and all authors contributed to experimental design. EEH conducted the experiments and analysed the data. All authors interpreted the data. EEH and APB wrote the manuscript with critical revisions from SGE.

This research was supported by a University of East Anglia PhD Studentship to EEH. The authors are grateful to Jelle Demanet for discussion regarding apparatus and procedure for Experiments 1 and 2.

Correspondence concerning this article should be addressed to Andrew P. Bayliss at the School of Psychology, Lawrence Stenhouse Building, University of East Anglia, Norwich, NR4 7TJ, UK. Email: [Andrew.P.Bayliss@uea.ac.uk](mailto:Andrew.P.Bayliss@uea.ac.uk)

**Abstract**

We investigated the effect of effort on implicit agency ascription for actions performed under varying levels of physical effort or cognitive load. People are able to estimate the interval between two events accurately, but they underestimate the interval between their own actions and their outcomes. This effect is known as ‘intentional binding’, and may provide feedback regarding the consequences of our actions. Concurrently with the interval reproduction task, our participants pulled sports resistance bands at high and low resistance levels (Experiments 1 and 2), or performed a working memory task with high and low set-sizes (Experiment 3). Intentional binding was greater under low than high effort. When the effort was task-related (Experiment 1), this effect depended on the individual’s explicit appraisal of exertion, while the effect of effort was evident at the group level when the effort was task-unrelated (physical, Experiment 2; mental, Experiment 3). These findings imply that the process of intentional binding is compromised when cognitive resources are depleted, either through physical or mental strain. We discuss this notion in relation to the integration of direct sensorimotor feedback with signals of agency and other instances of cognitive resource depletion and action control during strain.

*Keywords:* Sense of agency, temporal binding, intentional binding, experience of effort, time perception.

### **Physical and mental effort disrupts the implicit sense of agency**

It is important that the human motor system can efficiently process events which are the result of its own actions, and to discriminate these from events in the world for which it is not responsible. For instance, if I kick a ball and it knocks over and smashes a vase of flowers, I know my action of kicking the ball was responsible for the vase smashing. Self-authored events like this tend to be easy to identify and this feeling that ‘I did it’ is known as a sense of agency. Some actions are more effortful than others; kicking a ball as hard as one can might break a vase, but so might brushing one’s arm against it as one walks past it precariously positioned near the edge of a table. Both these actions have the same outcome, but might require the action monitoring system to respond differently in order to correctly ascribe agency. Here, we tested the role of physical and mental effort on the ascription of sense of agency, using an implicit measure.

#### **The attribution of agency**

Self-agency is detected where there are cues relating to intentionality, volition, predictability and contiguity. An interesting phenomena occurring under these conditions is that actions and their effects are perceived as occurring closer together in time than they did, an effect known as temporal or intentional binding (Barlas & Obhi, 2013; Engbert & Wohlschläger, 2007; Engbert, Wohlschläger, Thomas, & Haggard, 2007; Haggard, Clark & Kalogeras, 2002; see Moore & Obhi, 2012, for a review). One theory of subjective time perception suggests that ‘ticks’ of an ‘internal clock’ give rise to our sense of time passing. The pace of this clock varies with arousal and motor activity (Gibbon, Church & Meck, 1984; Treisman, 1963; Wearden Pilkington & Carter, 1999). When the pace of neural ‘ticks’ slows, durations appear shorter due to the accumulations of fewer pacing ‘ticks’. Conversely, when the pace of the ‘ticks’ quickens, durations appear longer. Contexts characteristic of self-agency are believed to slow the pace of the internal clock as a consequence of motor

prediction. This results in the shortening of subjective time and temporal binding (Wenke & Haggard, 2009). This may be an adaptive process to help to create a sense of agency, and in a general sense this process could assist the sensorimotor system to identify and monitor its effects and optimise performance (Buhrmann & Di Paolo, 2015; Wenke & Haggard, 2009).

Several accounts as to how agency is attributed to the self have been suggested, including the forward predictive comparator model (Blakemore, Frith & Wolpert, 2001; Blakemore, Wolpert & Frith, 2002; Wegner, Sparrow, & Winerman, 2004), the post-hoc inference account (Wegner & Wheatley, 1999), and the optimal cue integration account (Moore & Fletcher, 2012; Synofzik, Thier, Leube, Schlotterbeck, & Lindner, 2010; Synofzik, Vosgerau, & Lindner, 2009; Synofzik, Vosgerau, & Voss, 2013). The comparator model provides a predictive account of agency attribution, characterised by the comparison between predicted action effects with actual action effects. Congruence between these effects results in perceived self-authorship and a sense of agency, whereas incongruence results in diminished sense of agency.

An alternative model, the post-hoc inference account, provides a post-dictive reconstructionist account of agency attribution. Here, sense of agency self-attribution is dependent upon reflection on the action-effect relationship after the outcome has occurred. For instance, when there is an intention to act, when the perceived effects can be explained by the intended action, and when there is no other plausible cause for the effect, sense of agency is then experienced and retrospectively introduced into consciousness. Finally, the optimal cue integration account recognises the importance of both pre- and post-dictive cues. These cues are then weighted for their reliability for agency attribution depending on the context and then used to determine self-authorship. The ability to construct these cues and make comparisons between expected and actual effects of actions may depend on the availability of cognitive resources. Indeed, diminished attentional resources have been shown to impair

explicit ratings of agency (Hon, Poh, & Soon, 2013). Moreover, studies concerning cognitive load, kinematics and motor awareness offer support to this prediction. Dual task paradigms employing mental arithmetic, memory tasks and fine motor movements during balance, gait, posture and walking tasks have shown reductions in motor control and motor awareness (Kannape, Barré, Aminian & Blanke, 2014; Lindenberger, Marsiske & Baltes, 2000; Woollacott & Shumway-Cook, 2002). Dual task performance models suggest that motor control and cognitive activity compete for cognitive resources (Huxhold, Li, Schmiedek & Lindenberger, 2006; Lacour, Bernard-Demanze & Dumitrescu, 2008). In such cases motor control and awareness become less efficient due to cross-domain resource competition. The deficits in motor awareness caused by limited cognitive resources are especially of relevance to the sense of agency as, in accordance with the forward models of motor control, it is a crucial factor in the ability to monitor self-initiated actions. This cognitive resource limitation notion therefore has interesting implications regarding the role cognitive resource availability may have on constructing the attribution of agency.

### **Mental and Physical Effort**

We are concerned primarily with how effort might influence the implicit sense of agency. It is important then to note that despite appearing to be independent concepts, physical and mental effort similarly put strain on the cognitive system by expending cognitive resources (Dietrich, 2003; Dietrich & Sparling, 2004; Franconeri, Alvarez & Cavanagh, 2013). Mental and physical effort therefore draw from and deplete a common cognitive resource. It is also important to note that exertion influences perception in other domains. For instance, perceived distance increases and hills seem steeper under conditions requiring more physical exertion (e.g. when carrying a heavy load; Bhalla & Proffitt, 1999; Sugovic & Witt, 2013; Witt, Proffitt, & Epstein, 2004). These apparent spatial distortions as a function of required effort are also mirrored for the perception of time.

A recent meta-analysis investigating the effect of physical load on duration judgements revealed that physical workload results in longer perceived durations (Block, Hancock & Zakay, 2016; seven studies spanning from 1963 – 2011). However, the impact of effort on perceived duration need not be experiential, as stimuli that allude to motion, action, or exertion also elongate perceived durations. For example, faster moving non-biological stimuli are perceived to last longer than slower moving stimuli (Brown, 1995; Kaneko & Murakami, 2009), and the perceived duration of images of ballet dancer statues are lengthened when the poses reflected greater levels of exertion (Nather, Bueno, Bigand & Droit-Volet, 2011). The elongation of subjective time as a result of effort are also found for mental activity. Depleted attentional resources and increased cognitive load result in longer retrospective subjective time judgements (for a review see Block, Hancock, & Zakay, 2010). Given these findings highlighting the similarities between the effects of physical and mental effort on time perception, one can hypothesise that physical and mental exertion could have similar disruptive effects on temporal measures of the sense of agency, driven by the depletion of cognitive resources (Dietrich, 2003; Dietrich & Sparling, 2004, Franconeri et al., 2013; Hon et al., 2013).

### **Sense of agency and effort**

Given what we know about the effects of physical and mental exertion on performance and perception, and assuming that ascribing agency is a costly cognitive process, the hypothesis follows that agency should be reduced under conditions of mental or physical effort. There is some support for this hypothesis from a study using an explicit measure, where participants reported the degree to which they felt agency over an event (Hon et al., 2013). These authors found that explicit ratings of agency over a dot that moved following an arrow key press were reduced under conditions of high cognitive load, which was manipulated using a working memory task. This is an interesting finding but converging

evidence using an implicit task would be valuable in understanding the processes involved in agency attribution during strain. This is especially important given that explicit and implicit measures are sometimes found to be dissociated (Dewey & Knoblich, 2014; Obhi & Hall; 2011).

Some studies that have used implicit measures lend indirect support to the notion that mental effort disrupts the implicit sense of agency, though their research questions did not directly address the role of cognitive load. Specifically, temporal binding for self-actions has been shown to be weaker when the outcome of the action is socially negative (Yoshie & Haggard, 2013), or when the actor performs the action under coercion (Caspar, Christensen, Cleeremans & Haggard, 2016). Individual ratings of agency over outcomes to actions have also shown to be lower when there is conflict in action selection caused by distractor stimuli (Sidarus & Haggard, 2016). Indeed, each of these acts imply a significant degree of cognitive conflict (see Greene, Nystrom, Engell, Darley & Cohen, 2004), which would make their findings appear broadly in line with our hypothesis.

A general explanation of these effects could be drawn from the effect of resource depletion on time perception. As noted above, subjective time lengthens under load (Block, et al., 2010; 2016), which would result in less temporal binding (i.e. smaller underestimation errors) in agency conditions due to the resources required to bind the action and its effect together already being committed to the cognitively effortful primary task. However, the only research to have directly addressed cognitive effort during the task itself used an explicit measure (Hon et al. 2013), as did the research inducing conflict in action selection (Sidarus & Haggard, 2016). The work by Caspar et al. (2016) and Yoshie and Haggard (2011), although employing implicit measures, manipulated the outcome of, or the motivation for, the action, rather than the effort context under which the action itself was performed. Therefore, a direct test of how effort influences agency using an implicit measure would be valuable in

understanding the processes involved in agency attribution during strain, and determining if effort affects interval estimation measures of sense of agency in a comparable way to explicit ratings previous found (Hon et al., 2013).

One recent study has more directly investigated the effect of *physical* effort exerted during the action, using an implicit measure (Demanet, Muhle-Karbe, Lynn, Blotenberg & Brass, 2013). Levels of physical task-unrelated effort were manipulated so that the arm contralateral to the active hand used to carry out the time perception measure held an exercise resistance band. The authors used the ‘Libet clock’ method in which participants attempted to state where the hand on an analogue clock face had been both when they performed their action (a key press) and also when they heard the consequent tone. They compared these trials to baseline trials in which either only a key press occurred or only a tone sounded. In contrast to predictions one could derive from the above discussed research, Demanet et al. found that greater effort *increased* temporal binding, therefore implying a stronger implicit sense of agency under conditions of high task-unrelated physical effort. These findings were attributed to the notion that effortful actions boost the interoceptive sensory-motor information of willed effort, which may act as a cue to self-agency (Haggard et al., 2002; Lafargue & Franck, 2009; Vierkant, 2014).

The pattern of data observed by Demanet et al. (2013) and the conclusion drawn accord with Maine de Biran’s hypothesis (1805, as cited in Demanet et al.) that effort is a cue to identify self-agency. This explanation is convincing and a good account of their finding of enhanced temporal binding under effort. Nevertheless, their finding is contrary to what one might predict given that it is known that physical effort depletes cognitive resources, which is associated with time expansion, not compression, and that the depletion of cognitive resources reduces motor control and awareness - elements fundamental for agency ascription (Block et al., 2010; Block et al., 2016; Huxhold et al., 2006; Kannape et al., 2014). Hence, it



might be expected that the opposite effect would be observed; that exertion would result in disrupted – not enhanced - intentional binding. If the role of effort in reducing cognitive resources specifically disrupts the ascription of agency – rather than a general disruption of time perception - then it can be expected that effort will not have a similar disruptive effect during a passive control task in which agency is absent. To provide evidence that can help to establish the role of effort in implicit agency, we present three experiments that for the first time to our knowledge investigate the effect of task-related physical effort, and in further experiments, task-unrelated physical and mental effort, on implicit agency attributions.

### **The current study**

To determine whether physical and mental effort modulate agency over actions and their outcomes, a temporal binding paradigm measuring implicit agency was used. In particular, an interval reproduction paradigm, previously demonstrated to successfully show temporal binding in agentic tasks (Buehner & Humphreys, 2009; Engbert, Wohlschläger, & Haggard, 2008; Humphreys & Buehner, 2010; Poonian & Cunnington, 2013), was used here to measure implicit sense of agency. Experiments 1 and 2 investigate the role of task-related and task-unrelated physical effort on agency, respectively. In this way, Experiment 2 is a close replication of Demanet et al. (2013), except that we use an interval reproduction method of intentional binding and they used the ‘Libet clock’ method. Experiment 3 extends the examination of the effects of effort for sense of agency to the cognitive domain, investigating the role of mental effort in the form of cognitive load, for the ascription of agency. Experiment 3 can be compared with Hon et al, (2013) who investigated explicit measures of agency under varying load.

We believe these studies are the first to investigate the role of task-related physical effort on implicit agency. Moreover, these experiments are the first to investigate the influence of physical and mental effort on sense of agency using the interval reproduction

paradigm. Mental effort has also not before been directly investigated for its role in modulating implicit agency. Therefore, these features of our approach and design afford a more direct appraisal of different sources of effort on the implicit sense of agency than has been undertaken previously.

Given the common effects of physical and mental effort depleting cognitive resources, we can predict that high effort will result in a decrease in temporal binding across physical and mental effort in agentic conditions. However, the only previous study to investigate physical effort and sense of agency, found the converse effect, that high effort increased implicit agency (Demantet et al., 2013). Our investigation therefore also aims to clarify whether there is a general effect of effort on agency, or whether the specific context and source of the effort plays a critical role in the extent to which an implicit sense of agency is generated.

### **Experiment 1: Task-related physical effort**

The first experiment was designed to test the effects of task-related effort on implicit sense of agency. Participants made temporal reproductions of intervals between their action (depression of a key) and the consequence (a tone) whilst under low or high task-related physical effort, i.e. the arm under effort was the arm performing the actions and interval reproduction task. If effort acts as a cue that the self is acting in the environment, and therefore increases the sense of agency that the action generates, then greater temporal binding between actions and consequences whilst under high effort are expected. Alternatively, if effort depletes cognitive resources responsible for generating the agency signal, then more effortful actions will produce weaker temporal binding. We also asked participants to provide ratings of the subjective effort they exerted under low and high effort in order to allow us to examine relationships between subjective effort and agency.

## Method

The following applies to all three experiments. We report how we determined our sample size and all data exclusions (if any). We also report all manipulations and all measures in each experiment (Simmons, Nelson, & Simonsohn, 2012). Our target sample size for each experiment was  $n = 36$  based on Demanet et al. (2013), who tested a similar research question. We have also calculated that to achieve medium effect sizes (i.e.  $\eta_p^2 = .06$ ,  $r = 0.5$ ,  $d_z = 0.5$  at Power = 0.8,  $\alpha = .05$ ), a sample of  $n = 32$  was required. Our stopping rule was to aim for  $n = 36$ , but to stop near that number for convenience at the end of a run of laboratory bookings. We excluded single trials from all three experiments where the participant produced extreme interval reproductions ( $>3SD$  from the individual's mean). We excluded participants if their mean reproduction errors were  $>3SD$  from the group mean.

### Participants

Thirty-five participants aged 18-51 years ( $M = 22.2$  years,  $SD = 7.79$ ; six were men), recruited from the University of East Anglia, completed the experiment in return for payment or course credit. Participants gave informed consent and were naïve as to the research question. Because the experiment involved exertion while holding a latex exercise band, individuals with a latex allergy, or back, neck, arm or shoulder pain were excluded from participation. No participants met these exclusion criteria. The study was approved by the School of Psychology Research Ethics Committee, University of East Anglia.

### Apparatus & Stimuli

Physical effort was manipulated using Thera-Band® latex resistance bands which are typically used for exercise. The levels of effort were operationalised using two different resistance bands. This allowed for “Low” and “High” effort conditions using Thera-Bands® in colours yellow and blue, respectively. The amount of force required to hold the bands in the required position was approximately 24.5N and 4.9N for the high and low effort bands,

respectively. The bands were attached to a handrail that was fixed to the wall behind the participants, 94cm from the ground, positioned off to the right so that the band was pulled past the participant's trunk and held in the right hand over the space bar.

The position of the keyboard from the center of the space bar was approximately 40 cm from the front edge of the table. The height of the table was 71 cm. A tone (150ms, 440Hz; created using Audacity® software) was presented using Logitech speakers. Visual stimuli were presented (black text on a white background) using E-Prime® software on a Dell 1909W monitor (size: 19 inches; resolution: 1440 x 900; refresh rate: 60 Hz).

### **Design**

In a 2x2 repeated subjects design participants completed four experimental block types differing across two factors: “Presence of Agency” (“Agency” and “No Agency”) and “Physical Effort” (“Low” and “High”). The dependent measure was duration reproduction error, derived as the actual interval minus the reproduced interval (ms). Participants also rated how much effort they experienced whilst holding the low and high effort bands in the required position both before (“Pre”) and after (“Post”) the experimental blocks (scale from 1-10; 1 indicating low effort).

### **Procedure**

**Presence of Agency manipulation.** Instances of agency were manipulated using an Interval Reproduction task (Humphreys & Buehner, 2010; Poonian & Cunnington, 2013) in which participants were instructed that a tone would occur after a first event: either a self-initiated spacebar press with their index finger (“Agency”) or after a first auditory tone (“No Agency”). The stimulus interval was the delay between the first event and the outcome (randomised between 500-1500ms; as in Humphreys & Buehner, 2010; Poonian & Cunnington, 2013). Participants were immediately prompted to make response intervals by depressing the spacebar with their index finger for the duration they perceived the stimulus

interval to have lasted, after which a fixation cross was presented for 1000 ms and the trial ended (see Figure 1 for the Interval Reproduction task procedure).

FIGURE 1 ABOUT HERE

**Effort manipulation.** Throughout the interval reproduction task the level of physical effort was manipulated by having participants hold the end of a resistance band (“Low” or “High”) with their right hand, in a fixed position with their arm outstretched towards the spacebar which sat approximately 40cm from the table edge. This allowed for *task-related* induction of effort (we investigate task-unrelated effort in Experiment 2; see Figure 2 for the effort manipulation set-up). Participants were instructed before each block of trials as to which band to hold. After each block participants were encouraged to take self-paced rest periods.

FIGURE 2 ABOUT HERE

Before starting the experiment participants completed a short practice block involving the “Presence of Agency” and “Physical Effort” manipulations. The experiment consisted of eight blocks (two blocks per condition) of 20 trials per block. Each experimental condition therefore contained 40 trials. Condition order, manipulated across blocks, was counterbalanced so that one block of each condition was presented in the first half (blocks 1-4) and the second half of the experiment (blocks 5-8). The blocks in the first half of the experiment were counterbalanced with each possible order run through. The blocks in the second-half backwards mirrored the condition order in the first half. The experiment comprised 160 trials and typically took approximately 45 minutes.

**Effort manipulation check.** The effort manipulation was successful. This was confirmed by examining the effort ratings that participants gave to each band before and after the experiment in a 2 (“Physical Effort”; “Low” and “High”) X 2 (“Time”; “Pre” and “Post”) ANOVA. The main effect of ‘Physical Effort’ was significant,  $F(1, 34) = 522.76, p < .001$ ,

$\eta^2 = .94$ , due to higher effort ratings for the “High” compared with the “Low” effort resistance band ( $M = 6.83$ ,  $SD = 1.38$  and  $M = 2.26$ ,  $SD = 0.71$ , respectively). The main effect of ‘Time’ was non-significant,  $F(1, 34) = 1.4$ ,  $p = .25$ ,  $\eta^2 = .04$ . The interaction was significant,  $F(1, 34) = 33.18$ ,  $p < .001$ ,  $\eta^2 = .49$ , because the difference in ratings between high and low effort bands was larger after, compared with before, the experiment (Low effort band: “Pre”:  $M = 2.49$ ,  $SD = 1.01$ ; “Post”:  $M = 2.03$ ,  $SD = .82$ ;  $t(34) = 2.31$   $p = .027$ ,  $d_z = 0.39$ ; High effort band: “Pre”:  $M = 6.43$ ,  $SD = 1.46$ ; “Post”:  $M = 7.23$ ,  $SD = 1.46$ ;  $t(34) = 4.91$   $p < .001$ ,  $d_z = 0.83$ ).

## Results

Trials with extreme reproduction errors were removed (0.48% of trials). Mean reproduction errors for each participant in each condition (see Figure 3) were analysed using a 2 (“Presence of Agency”) X 2 (“Physical Effort”) ANOVA, revealing significant main effects of both of these factors:  $F(1, 34) = 54.54$ ,  $p < .001$ ,  $\eta^2 = .62$ , and  $F(1, 34) = 14.43$ ,  $p = .001$ ,  $\eta^2 = .3$ , respectively. These main effects were due to larger reproduction errors - more underestimation - in the “Agency” condition than the “No Agency” condition, ( $M = -322$  ms,  $SD = 236$  and  $M = -56$ ms,  $SD = 265$ , respectively). This replicates the basic temporal binding effect (Buehner & Humphreys, 2009; Haggard et al., 2002; Humphreys & Buehner, 2010; Poonian & Cunnington, 2013). There were larger reproduction errors in the ‘low’ effort compared with ‘high’ effort conditions,  $M = -208$  ms,  $SD = 230$  and  $M = -170$  ms,  $SD = 228$ , respectively. However, the critical interaction was non-significant,  $F(1, 34) = 2.12$ ,  $p = .154$ ,  $\eta^2 = .06$ .

### FIGURE 3 ABOUT HERE

Although the interaction – critical to our research question – was non-significant, we nevertheless performed two planned contrasts to investigate the nature of effects across “Presence of Agency” and “Physical Effort”. In the “Agency” condition, reproduction errors

were significantly larger under “Low” than “High” effort,  $t(34) = 3.46, p = .001, d_z = 0.589$ , while this effect was not significant in the no agency condition,  $t(34) = 1.59, p = .122, d_z = 0.27$ . Therefore, due to a non-significant interaction, the overall results do not support our hypothesis that reproduction errors in agency tasks would be reduced under greater physical effort.

As a supplementary analysis, we considered that individual susceptibility to the effort manipulation may play a critical role in determining the extent to which task-related effort might influence the implicit sense of agency. We therefore firstly determined the difference in effort ratings that participants gave to the low and high effort bands (averaged over ratings they gave pre- and post-experiment). Therefore, people who experienced a great deal of difference between how much effort they required to extend the high-effort band versus the low-effort band would have a high “Effort Differential” score, whereas people who felt that both bands required relatively similar exertion to maintain the extended position would have a low “Effort Differential” score. We examined whether this “Effort Differential” measure correlated with the “Reproduction Error Differential”: the difference in temporal binding between agency and no agency conditions under high vs. low effort conditions (i.e. [Agency High – No Agency High] – [Agency Low – No Agency Low]). A Pearson correlation revealed a significant positive relationship between the two variables,  $r(33) = .523, p = .001$  (see Figure 4), whereby as “Effort Differential” increases, so does “Reproduction Error Differential”. This correlation is also significant if we only consider the post-experiment ratings ( $r = .436, p = .009$ ). This means that only participants who felt the difference in effort they were exerting also showed an effect of effort on the implicit measure of agency. Overall, therefore, although the key interaction in the analysis was non-significant, this correlation clearly shows that this was related to the individual perception of the effort itself.

FIGURE 4 ABOUT HERE

Finally, we briefly report here a further analysis prompted by a reviewer (whom we thank for the suggestion), indicates an important role of duration of effort on agency. Specifically, we found that the reduction of temporal binding under high effort was stronger during the second half of trials (i.e. after the arm had been under strain for some time) than in the first half. This finding was supported by the outcome of a 3-way ANOVA with Presence of Agency, Effort, and the new factor Time on Task (1st half of trials vs. 2nd half of trials) as within-subject factors. The critical three way interaction was significant,  $F(1, 32) = 5.73, p = .023, \eta p^2 = .152$ . Next, to confirm the source of this 3-way interaction, we conducted 2-way ANOVAs on the two halves separately. The 2-way interaction was not significant during the 1st half of trials,  $F(1, 33) = 1.39, p = .248, \eta p^2 = .04$  (like in the overall analysis above). However the interaction was significant for trials in the 2nd half of the experiment,  $F(1, 32) = 4.473, p = .042, \eta p^2 = .123$ . This was due to reduced reproduction errors under high effort compared with low effort in “Agency” conditions,  $t(33) = 4.52, p < .001, dz = 0.78$  ( $M = -354, SD = 274$  and  $M = -260, SD = 283$ , respectively). In “No Agency” conditions this effect was not observed,  $t(33) = 1.38, p = .177, dz = 0.24$  ( $M = -47, SD = 286$  and  $M = -24, SD = 287$ , respectively). It therefore appears that the effect of high effort on temporal binding increases with time on task.

## Discussion

Overall, the data indicate agency effects in that there was greater temporal binding during conditions in which agency was present, replicating previous work (Buehner & Humphreys, 2009; Engbert & Wohlschläger, 2007; Engbert et al., 2007; Haggard et al., 2002; Humphreys & Buehner, 2010). However, there was no reliable difference in the effect of agency on interval reproduction errors across different levels of effort. Nevertheless, although the critical interaction was indeed non-significant, the contrast between effort levels in agency conditions was significant, but in the opposite direction to that found by Demanet et



al. (2013). Specifically, there was stronger binding (which implies greater implicit sense of agency) under low effort than under high effort. This discrepancy with Demanet et al's finding could be explained by the difference in how implicit agency was measured. We used the interval reproduction paradigm, whereas Demanet et al used the Libet clock method. However, it is not clear what aspect of these two methods might result in such divergent findings. Another key difference between our procedure and that of Demanet and colleagues is that the present Experiment 1 involved the participants engaging in task-related effort (the hand used to act was under strain) whereas a passive arm was under strain in Demanet et al. In Experiment 2 we test whether this latter difference accounts for the disparate findings by having our participants engage in task-unrelated effort, like Demanet and colleagues' participants.

Although the critical agency by effort interaction did not approach significance at the group level, we did find a significant medium-sized effect when investigating individual appraisals of exertion. Participants who experienced the high effort manipulation as much more exertive than the low effort manipulation demonstrated a larger disparity in binding difference across the low and high physical effort conditions. We also found a medium-sized effect when investigating the build-up of fatigue, such that in the second half of the experiment temporal binding was reduced under conditions of agency under high effort. Therefore, we are able to draw reasonably strong conclusions from these data overall despite the lack of a clear effect at the group- and full session-level; high effort did indeed reduce the sense of agency, but only for participants who registered the exertion as more effortful than the low effort condition, and also in the second half of the experimental session, after fatigue from the effort had set in. Therefore, we are able to draw reasonably strong conclusions from these data overall despite the lack of a clear effect at the group-level; high effort did indeed reduce the sense of agency, but only for participants who registered the exertion as effortful,

or after the build-up of fatigue. We note again here, that these findings are in the context of task-related physical effort, so it is important to establish whether these effects (in particular the individual differences effect) are specific to task related effort. Therefore, in addition to testing conditions closer to Demanet et al. by using task-unrelated effort, Experiment 2 also allows us to examine again the influence of individual-level experience on the modulatory impact of effort on the sense of agency.

### **Experiment 2: Task-unrelated physical effort**

Experiment 2 aimed to investigate whether modulations of temporal binding by effort are limited to task-related effort (Experiment 1) by making the effort in this experiment unrelated to the interval reproduction task performance. To do so, participants in this experiment held the band with the hand contralateral to the hand carrying out the interval reproduction and agency task. If temporal binding is affected by general experience of physical effort, that need not be undertaken as a necessary part of the action creating the cause-effect outcomes in the environment, then we expect to observe results similar to Experiment 1. That is, high task-unrelated effort reduces temporal binding between action and effect. Alternatively, if there is something action-specific about the nature of the effort – task-related compared with task-unrelated – then we may instead show a reverse pattern and replicate Demanet et al.'s (2013) finding of greater binding under high effort.

## **Method**

### **Participants**

Thirty-five participants (7 men; age range 18-54,  $M = 21.26$ ,  $SD = 6.28$ ) recruited from the University of East Anglia, completed the experiment in return for payment or course credit. Participants gave informed consent and were naïve as to the research question. As the experiment involved exertion while holding a latex exercise band, individuals with a latex

allergy, or back, neck, arm or shoulder pain were excluded from participation. No participants were excluded from participation due to this criteria.

### **Apparatus, Design and Procedure**

The only alteration compared with Experiment 1 was that the resistance band was held in the left hand to allow for task-unrelated physical effort. Participants still responded to the interval reproduction task with their right hand, as in Experiment 1. The band was attached to a handrail fixed to the wall 94 cm from the ground on the left hand side of the participant. The band was pulled with the left hand towards the left side of the keyboard until the wrist was in line with the spacebar. The band was held in this position for the entire block of trials (see Figure 2 for effort manipulation set-up).

**Effort Manipulation Check.** The effort manipulation was successful, as confirmed by the same analysis as in Experiment 1. The main effect of ‘Physical Effort’ was significant,  $F(1, 33) = 251.97, p < .001, \eta^2 = .88$  (High:  $M = 5.97, SD = 1.47$ ; Low:  $M = 2.02, SD = .68$ ). The main effect of “Time” was significant,  $F(1, 33) = 5.8, p = .022, \eta^2 = .15$ , because effort ratings were higher after than before the experiment ( $M = 4.18, SD = .91$ ;  $M = 3.81, SD = 1.06$ , respectively). The interaction was also significant,  $F(1, 33) = 21.83, p < .001, \eta^2 = .4$ , because the difference between high and low effort ratings was larger after the experiment than before (High:  $t(33) = 4.12, p < .001, d_z = 0.71$ ; Post  $M = 6.38, SD = 1.52$ , Pre  $M = 5.56, SD = 1.64$ ; Low:  $t(33) = .55, p = .59, d_z = 0.1$ ; Post  $M = 1.97, SD = .8$ , Pre  $M = 2.06, SD = .85$ ).

### **Results**

A total of 0.55% of trials were removed as outliers. One participant was further removed for having extreme mean reproduction errors. The remaining data were submitted to the same analysis as in Experiment 1 (see Figure 3). This revealed a main effect of “Presence of Agency”,  $F(1, 33) = 65.98, p < .001, \eta^2 = .67$ , with larger reproduction errors during “Agency” compared with “No Agency” conditions ( $M = -273$  ms,  $SD = 189$ , and  $M = 24$  ms,

$SD = 252$ , respectively). The main effect of “Physical Effort” was also significant,  $F(1, 33) = 5.03, p = .032, \eta^2 = .13$ , with smaller reproduction errors under “High” than “Low” effort ( $M = -106$  ms,  $SD = 205$ ;  $M = -143$  ms,  $SD = 198$ , respectively). Critically, and unlike Experiment 1, the interaction between these factors was also significant,  $F(1, 33) = 4.16, p = .049, \eta^2 = .11$ . Planned contrasts revealed that in “No Agency” conditions there was no difference between the effort conditions under “No Agency”,  $t(33) = .62, p = .542, d_z = 0.11$ . Whereas, in “Agency” conditions “High” effort resulted in smaller reproduction errors compared with “Low” effort,  $t(33) = 2.94, p = .006, d_z = 0.5$ .

Similarly, to Experiment 1, we tested whether the difference between the effort participants stated that they exerted in the high vs. low effort conditions was related to the increase in binding difference between agency and no-agency conditions in the low effort condition relative to the high effort condition. The correlation was not significant whether the mean of the pre- and post-experiment ratings were used,  $r(32) = -.147, p = .407$ , or only the post-experiment ratings ( $p = .33$ ). This stands in stark contrast to the findings of Experiment 1 where there was a moderate and significant relationship between the two variables, whereby the effect of effort on implicit agency was related with the explicit ratings of exertion. The correlation coefficients from Experiment 1 ( $r = .523$ ) and Experiment 2 ( $r = -.147$ ) differ significantly from one another ( $z = 2.89, p = .004$ ).

As in Experiment 1, we investigated the effect of the factor ‘Time on Task’ to compare performance in the first half of the session with the second half. The three-way interaction was non-significant,  $F(1, 33) = 1.41, p = .24, \eta^2 = .041$ , indicating that unlike

Experiment 1, the effect of effort on temporal binding was consistent through the experimental session.

### **Discussion**

We again replicated the general finding of temporal binding under conditions of agency (Buehner & Humphreys, 2009; Engbert & Wohlschläger, 2007; Engbert et al., 2007; Haggard et al., 2002; Humphreys & Buehner, 2010), and this effect was weaker under high effort, even though the effort was task-unrelated. In Experiment 2, this effect of effort on binding was reliable at the group level (i.e. the critical effort by agency interaction was significant), but there was little role for individual appraisal of the subjective effort required, and was constant across the session, unlike in Experiment 1. Notably, our data are in the opposite pattern to that observed by Demanet et al. (2013).

In Experiment 3, we aimed to explore whether the effect we observed in Experiment 2 would replicate under conditions of a different type of effort, where no physical strain is required whatsoever. Instead, we note that the cognitive system is depleted similarly under physical and mental effort, and at least with our data, the effect of effort appears to be not completely action-specific. Therefore, we predict that high mental effort tasks will result in reduced binding in agency conditions, compared with low mental effort, replicating Experiment 2.

### **Experiment 3: Mental effort**

In this experiment, participants were exposed to high and low levels of cognitive load, using a working memory task whereby items (2 or 8 for low and high effort levels, respectively) had to be kept in working memory during the stimulus interval and reproduction of this interval (adapted from Sternberg, 1966). If we again find that temporal binding is reduced under high (cognitive) effort, it would suggest that implicit sense of agency is

vulnerable under conditions of effort, regardless of the source. This would mirror the data of Hon et al. (2013) who found a similar pattern using an explicit ratings task.

## **Method**

### **Participants**

Thirty-six participants (6 men; age range 18-29,  $M = 20.39$   $SD = 2.05$ ) recruited from the University of East Anglia, completed the experiment in return for payment or course credit. Participants gave informed consent and were naïve as to the purpose of the experiment.

### **Apparatus and Stimuli**

Experiment 3 examined the effect of cognitive load on temporal binding. To manipulate this, randomly selected letters (vowels and ‘y’ excluded, Arial font, font size 36, presented in white on a black background at encoding stage, and yellow font presented on a black background for probe letters) served as additional stimuli as part of the Sternberg (1966) memory task. Physical effort was not manipulated so the resistance exercise bands were not used in this experiment. Participants were tested in a group lab up to four participants at a time, but were separated in booths with no access to each other during the task. Stimuli were presented on a BenQ monitor (size: 24 inches; resolution: 1920 x 1080 refresh rate: 60 Hz) Auditory stimuli were presented using Sony 7506 headphones. The Adult Empathy Quotient (Baron-Cohen & Cartwright, 2004) was also administered at the end of the testing session as part of a pilot study for an unrelated research question and so is not discussed further.

### **Design**

In a repeated subjects design participants completed four experimental block types differing across two factors: “Presence of Agency” (“Agency” and “No Agency”) and cognitive load under the factor “Mental Effort” (“Low” and “High”). Sense of agency was

measured, as in Experiments 1 and 2, as reproduction errors (calculated as the subtraction of stimulus intervals from response intervals). “Reproduction Error Differential” was calculated as in Experiments 1 and 2. During the “Mental Effort” manipulation, memory accuracy performance was recorded, from which an “Accuracy Difference” was calculated as accuracy score (percentage accurate) under “Low Mental Effort” minus accuracy score under “High Mental Effort”.

### **Procedure**

**Effort manipulation.** Mental effort was manipulated using the Sternberg (1966) Memory task, adapted to administer “Mental Effort” under “Low” and “High” levels of cognitive load. The Memory task consisted of an encoding stage, a maintenance period, and a recall stage. During the encoding stage a series of randomly selected letters were presented successively for 1000 ms each. For “Low” and “High” “Cognitive Load” conditions two and eight letters, respectively, were presented at the encoding stage. The Interval Reproduction task served as the maintenance period, which was followed by the recall stage. The recall stage consisted of a probe letter to which participants distinguished whether or not (pressing ‘1’ and ‘2’, respectively) the probe was present at encoding, which was the case in 50% of trials (at random).

**Presence of Agency manipulation.** Agency was manipulated as in Experiments 1 and 2, using an Interval Reproduction task. Before starting the experiment participants completed a short block practicing the “Presence of Agency” and “Mental Effort” manipulations. Each experimental condition contained 36 trials which were presented in two blocks of 18 trials each. Blocks were separated by a self-paced rest period. The order of block type was counterbalanced as in Experiments 1 and 2. At the end of each block participants were encouraged to take an unrestrained rest period. The full experiment lasted approximately 45 minutes (see Figure 5).

## FIGURE 5 ABOUT HERE

**Cognitive Load Manipulation Check.** Accuracy data percentages were analysed across the two factors (“Presence of Agency” and “Mental Effort”) using a 2 X 2 ANOVA. A main effect of “Mental Effort” was observed,  $F(1, 33) = 176.06, p < .001, \eta^2 = .84$ , because participants recalled more accurately under low compared to high load ( $M = 92.28\%$ ,  $SD = 5.9$ , and  $M = 72.39\%$ ,  $SD = 7.4$ ). Neither main effect of “Presence of Agency”, nor the interaction between the two factors were significant,  $F$ 's < 1.

### Results

Data from one participant were removed because they omitted to perform responses during the working memory task. Trials with extreme reproduction errors were removed (0.54% of trials), as were trials in which responses in the recall stage were inaccurate (17.5%). One additional participant produced extreme interval reproduction scores and therefore was not submitted to further analysis.

Mean reproduction errors for each participant in each condition were submitted to a 2 (“Presence of Agency”) X 2 (“Mental Effort”) ANOVA, which revealed a significant main effect of “Presence of Agency”,  $F(1, 33) = 69.74, p < .001, \eta^2 = .68$ , whereby “Agency” tasks had greater reproduction errors than “No Agency” tasks ( $M = -215$  ms,  $SD = 253$  and  $M = -22$  ms,  $SD = 323$  ms, respectively). There was no main effect of “Mental Effort”,  $F(1, 33) < 1$ , but the interaction was significant,  $F(1, 33) = 4.56, p = .04, \eta^2 = .12$ .

Planned contrasts examined the interaction revealing that for “No Agency” tasks there was no effect of effort,  $t(33) = .88, p = .39, d_z = 0.149$ . However, for “Agency” tasks an effect of “Mental Effort” was observed,  $t(33) = 2.1, p = .044, d_z = 0.36$ , whereby reproduction errors were greater under “Low” effort (see Figure 3).

In this experiment, we did not ask participants to provide ratings of how much effort they exerted under high and low effort. Instead, we have the objective measure of their



performance as a proxy for effort. That is, an individual's difference in accuracy between the high and low cognitive load conditions can be used as an index of how much more taxing the high load task was relative to the low, for each individual. Like before, this was correlated with the difference in the effect of agency between the high and low effort conditions. The correlation was not significant,  $r(33) = -.113$ ,  $p = .523$ , and was significantly weaker than the significant positive correlation from Experiment 1 ( $z = 2.73$ ,  $p = .006$ ). As in Experiments 1 and 2, we compared the performance on the first and second halves of the experiment with the factor 'Time on Task'. The three-way interaction was non-significant,  $F(1, 33) < 1$ , meaning that the effect of effort on agency was consistent across the experiment session.

Finally, we report here for completion a preliminary experiment we conducted before we ran Experiment 3. This differed from Experiment 3 in that the high load condition was not as taxing, using only a set size of 6 instead of 8. With this lower high set size, the critical effort x agency interaction was also significant, as in Experiment 3,  $F(1, 35) = 5.0$ ,  $p = .03$ ,  $\eta^2 = .13$ , due to a weaker effect of agency under the high load condition. However, the contrast comparing temporal binding in the agency conditions did not differ significantly between high (-194ms) and low (-220ms) load ( $p = .12$ ). We interpreted this as limited evidence for reduced implicit agency under cognitive load, and this motivated us to test a higher load level (8), which we presented here in full as Experiment 3.

### **Discussion**

Experiment 3 aimed to determine effort effects in action-unrelated cognitive load on temporal binding. In addition to the basic temporal binding effect under conditions of agency, an interaction with effort was also observed. In conditions in which agency was present, high mental effort decreased temporal binding compared with low mental effort conditions. This effect of mental effort was not observed in conditions in which agency was absent. These effects on temporal binding therefore reflect those found for both action-related and –

unrelated physical effort (Experiments 1 and 2, respectively). As in Experiment 2, here there was no modulatory role the individual experience of effort, nor of time on task, on the effect of effort on temporal binding. Taken together, the data we have collected using the cognitive load task shows that mental effort reduces temporal binding under conditions of agency, which is in line with that observed using explicit measures (Hon et al., 2013).

### **General discussion**

The current study investigated the role of both physical and mental effort for the modulation of implicit sense of agency. Using an interval reproduction paradigm, the amount of temporal binding between events in an agentic context (a self-made action and a consequent tone) compared with events which were not agentially related (two tones), was measured. Interval reproductions that are shorter than the actual length of the interval represent temporal binding between the events, whereby the events are perceived as closer together - 'bound' - in time. This measure is thought to be a valid implicit measure of the degree of agency that the cognitive system ascribes to a given event (Engbert & Wohlschläger, 2007; Engbert et al., 2007; Haggard et al., 2002; Moore & Obhi, 2012). In each experiment, we found temporal binding under conditions of agency, but not under passive conditions, replicating prior work (Buehner & Humphreys, 2009; Engbert & Wohlschläger, 2007; Engbert et al., 2007; Haggard et al., 2002; Humphreys & Buehner, 2010; Moore & Obhi, 2012). Of critical interest was whether task-related (Experiment 1), task-unrelated (Experiment 2) and mental (Experiment 3) effort would modulate this effect of agency on temporal interval reproduction.

Overall, our data revealed that in conditions of agency temporal binding was weaker under high, compared with low effort (however, note that for Experiment 1, the key interaction was non-significant). This effect was not observed for conditions absent of agency. In general terms, this effect was consistent across experiments and statistical effect

sizes were medium for the key interactions and correlations (Experiment 1 – key correlation  $r = .52$ ; Experiment 2 – key interaction  $\eta_p^2 = .11$ ; Experiment 3 - key interaction  $\eta_p^2 = .12$ ) and small to medium for the key contrasts (Experiments 1-3  $d_z$ 's 0.26, 0.50, 0.36, respectively). It is also worth noting that the key interactions in Experiments 2 and 3 reached the conventional .05  $p$ -value threshold by rather small margins, which suggests that although our sample size was calculated as sufficient to reveal the predicted effect sizes, future replication attempts may benefit from a larger sample to detect and confirm these small to medium statistical effect sizes.

### **Potential mechanisms for reduced sense of agency under effort**

Here we found that high effort resulted in a perceived shortening of the time between actions and their consequences (in Experiment 1 this effect is modulated by the subjective experience of effort). Importantly, this effect was not observed for conditions in which agency was not present. A commonality across each of our experiments is that we can assume that in the high load conditions, they either directly (Experiment 3) or indirectly (Experiments 1 and 2) draw on cognitive resources (Block et al., 2016). If we assume that agency ascription is itself cognitively costly, for reason we explain below, then under conditions of compromised cognitive resource availability, such as high effort, temporal binding would be weaker. This would be because there are less resources to dedicate to agency signal generation due to resource depletion during effort exertion. This would explain our data from Experiments 2 and 3, and somewhat the data from Experiment 1. Indeed, such reductions in temporal binding have been previously observed in conditions characteristic of cognitive conflict, such as coercion and negative social emotional consequences (Caspar et al., 2016; Yoshie & Haggard, 2013).

Dual process accounts of cognitive and motor control also lend indirect support for this cognitive resource competition theory for sense of agency (Huxhold et al, 2006; Lacour

et al., 2008). Cognitive loading causes a reduction in balance and movement accuracy due to limited cognitive resource availability for motor awareness (Kannape et al., 2014; Lindenberger et al, 2000; Woollacott & Shumway-Cook, 2002). According to internal forward models of motor control, self-agency over an action occurs when motor predictions of the action and sensory consequences match (Blakemore et al., 2001; 2002). We propose that reductions in motor awareness caused by limited cognitive resources, disrupt the ability of the system to create accurate predictions concerning sensory effects and outcomes of willed actions. This then results in a diminished sense of agency. Therefore, when cognitive resources are challenged, in the current case, by mental or physical strain, resources are less available to generate accurate motor awareness, which in turn disrupts the ascription of self-agency. The reduction of temporal binding under high effort in agency conditions in our experiments may be demonstrative of this mechanism.

#### **Action-specific effort effects**

Overall, our data suggest that there may be a general effect of effort on implicit sense of agency, whereby high effort reduces temporal binding. However for action specific effort (Experiment 1) this effect is dependent on the subjective experience of effort and effort induced fatigue. That is, for those under task-related effort, we find that the more effort experienced, either for individual differences in subjective effort experienced, or for task induced fatigue over time, the stronger the deleterious effect of high effort is on temporal binding. This modulation of individual appraisals of effort may endorse the cognitive resource depletion account that we suggest. Whereby, high effort, or - in the case of Experiment 1 - those who experience the action specific effort as highly effortful, depletes cognitive resources otherwise used for enhancing motor awareness and therefore disrupts agency ascription and temporal binding (Blakemore et al., 2001; Blakemore et al., 2002; Kannape et al., 2014; Lindenberger et al, 2000; Woollacott & Shumway-Cook, 2002).

Subjective task difficulty has been shown to be related to effort expenditure (Ennis, Hess & Smith, 2013). Those who experienced the high task-related effort as less effortful would require less cognitive resources to maintain the effort manipulation. In these individuals, cognitive resources are available for motor awareness and agency ascription. This account explains both the correlation between the effect of effort on binding and the subjective experience of effort, and also the effect of time-on-task in Experiment 1. Interestingly, this effect is not observed in task-unrelated physical or mental effort. To explain this, we consider that when under task-unrelated effort, the effort manipulation may have an indirect but strong effect on the efficiency of the mechanism by which agency is ascribed which outweighs the role of individual experience of effort. This effect could be due to the dual task demands of processing the effort manipulation with one effector, and the action with another (Experiment 2), which could be more demanding than processing input from a common source as in Experiment 1 (cf. Kahneman, 1973; Pashler, 1994).

### **Limitations and future work**

This investigation into the role of effort on sense of agency was in part designed to complement the work of Demanet et al. (2013). However, we found the opposite pattern of results compared with their study. Demanet et al. found that high task-unrelated effort resulted in greater temporal binding compared with low effort with the explanation that the sensation of effort acts as a cue inferring self-agency resulting in greater temporal binding. Demanet et al. used the ‘Libet clock’ method whereas we used interval reproduction as the implicit measure of agency. It is possible that the differences in the pattern of results may be due to methodological differences. The interval reproduction method captures the temporal relationship between the action and consequence and reflects the slowing of an internal clock (Wenke & Haggard, 2009), whereas the ‘Libet clock’ method captures the temporal positioning of either the action or consequence, and not the relationship between those two

events, so reflects shifts in event perception. Although, it is not completely clear how these two methods would produce divergent results, so it is important that future work pursues this empirical question.

Other work has indirectly investigated the role of cognitive resources on temporal binding as a measure for an implicit sense of agency, finding opposite effects in line with Demanet et al. (2013). Haggard and Cole (2007) investigated the role of focused attention on temporal binding. In the study participants' attention was directed to one of two events, either towards the key press action or - in other trials - to the consequent tone. They found that focused attention on one event resulted in a perceptual event shift in a manner reflecting temporal binding that was stronger for the attended event. Another study that indirectly manipulated cognitive load also found increased temporal binding when the number of action choices was greater (Barlas & Obhi, 2013). The key differences between these two studies and ours are that we aimed to directly manipulate mental effort exerted during the task overall, and moreover, our manipulation was unrelated to the pertinent action, whereas Haggard and Cole directed mental effort to different aspects of the task itself, and Barlas and Obhi manipulated the difficulty of the task. Both these papers showed the opposite of what we report. However, we also note that Hon et al. (2013) showed that explicit agency is reduced – like our present finding with implicit agency – using a similarly non-task-focused manipulation of mental effort. It is therefore likely that the effect of mental effort on agency may critically depend on the source of the cognitive load. The current study did not assess hand dominance or individual levels of strength. These issues could be looked at in order to personalise and equate across effectors in investigations of task-related and unrelated physical effort.

Future work could investigate the neural processing of events under conditions of agency and without agency while manipulating effort. The N1 event-related potential is

suppressed in response to events that the participant themselves has caused (Caspar et al., 2016; Poonian, McFadyen, Ogden & Cunnington, 2015). This suppression is thought to index sense of agency due to top-down motor predictions causing a suppression of the processing of the effects of actions (Gentsch, Kathmann & Schutz-Bosbach, 2012). It is possible that under cognitive or physical strain, this neural marker for agency could be attenuated (i.e. less N1 suppression). Indeed, under conditions that are arguably high in cognitive conflict (and therefore load), the N1 suppression is weaker (e.g. under coercion, Caspar et al., 2016).

Everyday life consists of effortful actions, fatigue, strain, stress and multitasking. The current study suggests that individuals under these conditions may feel an impaired sense of agency for their actions. This could have implications for moral decision making and responsibility, especially in environments in which cognitive resources are challenged (Caspar et al., 2016). For instance, the feeling of responsibility for actions that lead to accidents may reduce under conditions of fatigue and stress. Indeed, this could be one mechanism by which the action monitoring system itself fails to provide adequate action control under fatigue/stress, leading to erroneous or negligent acts. This notion could have further implications for how the law manages responsibility for actions in the context of mental and physical fatigue.

Finally, we consider the relationship between explicit and implicit measures of agency. We did not measure explicit agency ratings in this study. However, previous work has noted that high effort actions are associated with a greater feeling of will over action (Lafargue & Franck, 2009), whereas our data suggest that effort reduces implicit agency. Indeed, some authors have noted a dissociation between such measures, finding implicit agency measures and explicit judgments to be unrelated to one another (Dewey & Knoblich, 2014; Obhi & Hall, 2011). This again suggests that different sources of cues (e.g. sensorimotor feedback, temporal binding, retrospective judgements of agency) may

contribute to the different levels of agency, and are themselves affected by different variables, accounting for dissociations between how responsible we can say we felt about an action compared with implicit measures. It could therefore be that manipulating effort in these paradigms could be a useful variable to explore the relationship between implicit and explicit measures of agency.

### **Conclusion**

The present studies investigated the influence of physical and mental effort on temporal binding. It was found that the binding effect was reduced whilst under high effort in agentic conditions. It is concluded that effort generally and non-specifically affects implicit sense of agency, thought to be caused by depleted cognitive resources that would be otherwise dedicated to agency detection. When the effort is exerted by the same effector as that which is producing the environmental outcome, however, there is a more specific effect of effort whereby the individual's subjective experience of effort is taken into account. These results therefore further imply that a sense of agency is not necessarily generated in a uniform manner for any given action. Rather, the current state of the motor or cognitive system can disrupt a key mechanism that provides feedback about our actions in the environment.



### References

- Barlas, Z., & Obhi, S. S. (2012). Freedom, choice, and the sense of agency. *Frontiers in human neuroscience*, 7, 514-514.
- Baron-Cohen, S., & Wheelwright, S. (2004). The empathy quotient: an investigation of adults with Asperger syndrome or high functioning autism, and normal sex differences. *Journal of Autism and Developmental Disorders*, 34(2), 163 – 175.
- Bhalla, M., & Proffitt, D. R. (1999). Visual–motor recalibration in geographical slant perception. *Journal of Experimental Psychology: Human Perception and Performance*, 25(4), 1076.
- Biran, M. d. (1805). *Mémoire sur la décomposition de la pensée (Tome III)*. Vrin, Paris (1963).
- Blakemore, S. J., Frith, C. D., & Wolpert, D. M. (2001). The cerebellum is involved in predicting the sensory consequences of action. *Neuroreport*, 12(9), 1879-1884.
- Blakemore, S. J., Wolpert, D. M., & Frith, C. D. (2002). Abnormalities in the awareness of action. *Trends in cognitive sciences*, 6(6), 237-242.
- Block, R. A., Hancock, P. A., & Zakay, D. (2010). How cognitive load affects duration judgments: A meta-analytic review. *Acta Psychologica*, 134(3), 330-343. doi: 10.1016/j.actpsy.2010.03.006
- Block, R. A., Hancock, P. A., & Zakay, D. (2016). Physical load affects duration judgements: a meta-analytic review, *Acta Psychologica*, 165, 43-47.
- Brown, S. W. (1995). Time, change, and motion: The effects of stimulus movement on temporal perception. *Perception & Psychophysics*, 57, 105-116.
- Buehner, M. J., & Humphreys, G. R. (2009). Causal binding of actions to their effects. *Psychological Science*, 20(10), 1221-1228.

- Buhrmann, T., & Di Paolo, E. (2015). The sense of agency—a phenomenological consequence of enacting sensorimotor schemes. *Phenomenology and the Cognitive Sciences*, 1-30.
- Caspar, E. A., Christensen, J. F., Cleeremans, A., & Haggard, P. (2016). Coercion changes the sense of agency in the human brain. *Current biology*, 26(5), 585-592.
- Demanet, J., Muhle-Karbe, P. S., Lynn, M. T., Blotenberg, I., & Brass, M. (2013). Power to the will: how exerting physical effort boosts the sense of agency. *Cognition*, 129(3), 574-578. doi: 10.1016/j.cognition.2013.08.020
- Dewey, J. A., & Knoblich, G. (2014). Do implicit and explicit measures of the sense of agency measure the same thing? *PloS one*, 9(10), e110118.
- Dietrich, A. (2003). Functional neuroanatomy of altered states of consciousness: the transient hypofrontality hypothesis. *Consciousness and cognition*, 12(2), 231-256.
- Dietrich, A., & Sparling, P. B. (2004). Endurance exercise selectively impairs prefrontal-dependent cognition. *Brain and cognition*, 55(3), 516-524.
- Engbert, K., & Wohlschläger, A. (2007). Intentions and expectations in temporal binding. *Consciousness and Cognition*, 16(2), 255-264. doi: 10.1016/j.concog.2006.09.010
- Engbert, K., Wohlschläger, A., & Haggard, P. (2008). Who is causing what? The sense of agency is relational and efferent-triggered. *Cognition*, 107(2), 693-704. doi: 10.1016/j.cognition.2007.07.021
- Engbert, K., Wohlschläger, A., Thomas, R., & Haggard, P. (2007). Agency, subjective time, and other minds. *Journal of Experimental Psychology: Human Perception and Performance*, 33(6), 1261-1268. doi: 10.1037/0096-1523.33.6.1261
- Ennis, G. E., Hess, T. M., & Smith, B. T. (2013). The impact of age and motivation on cognitive effort: Implications for cognitive engagement in older adulthood. *Psychology and aging*, 28(2), 495.

- Franconeri, S. L., Alvarez, G. A., & Cavanagh, P. (2013). Flexible cognitive resources: competitive content maps for attention and memory. *Trends in cognitive sciences*, *17*(3), 134-141.
- Gentsch, A., Kathmann, N., & Schütz-Bosbach, S. (2012). Reliability of sensory predictions determines the experience of self-agency. *Behavioural brain research*, *228*(2), 415-422.
- Gibbon, J., Church, R. M., & Meck, W. H. (1984). Scalar timing in memory. *Annals of the New York Academy of sciences*, *423*(1), 52-77.
- Greene, J. D., Nystrom, L. E., Engell, A. D., Darley, J. M., & Cohen, J. D. (2004). The neural bases of cognitive conflict and control in moral judgment. *Neuron*, *44*(2), 389-400.
- Haggard, P., Clark, S., & Kalogeras, J. (2002). Voluntary action and conscious awareness. *Nature Neuroscience*, *5*(4), 382-385.
- Haggard, P., & Cole, J. (2007). Intention, attention and the temporal experience of action. *Consciousness and cognition*, *16*(2), 211-220.
- Hon, N., Poh, J. H., & Soon, C. S. (2013). Preoccupied minds feel less control: sense of agency is modulated by cognitive load. *Consciousness and Cognition*, *22*(2), 556-561. doi: 10.1016/j.concog.2013.03.004
- Humphreys, G. R., & Buehner, M. J. (2010). Temporal binding of action and effect in interval reproduction. *Experimental Brain Research*, *203*(2), 465-470. doi: 10.1007/s00221-010-2199-1
- Huxhold, O., Li, S. C., Schmiedek, F., & Lindenberger, U. (2006). Dual-tasking postural control: aging and the effects of cognitive demand in conjunction with focus of attention. *Brain research bulletin*, *69*(3), 294-305.
- Kahneman, D. (1973). *Attention and effort*. Englewood Cliffs, NJ: Prentice-Hall.

- Kaneko, S., & Murakami, I. (2009). Perceived duration of visual motion increases with speed. *Journal of Vision, 9*(7), 14-14.
- Kannape, O. A., Barré, A., Aminian, K., & Blanke, O. (2014). Cognitive loading affects motor awareness and movement kinematics but not locomotor trajectories during goal-directed walking in a virtual reality environment. *PloS one, 9*(1), e85560.
- Lacour, M., Bernard-Demanze, L., & Dumitrescu, M. (2008). Posture control, aging, and attention resources: models and posture-analysis methods. *Clinical Neurophysiology, 38*(6), 411-421.
- Lafargue, G., & Franck, N. (2009). Effort awareness and sense of volition in schizophrenia. *Consciousness and Cognition, 18*(1), 277-289. doi: 10.1016/j.concog.2008.05.004
- Lindenberger, U., Marsiske, M., & Baltes, P. B. (2000). Memorizing while walking: increase in dual-task costs from young adulthood to old age. *Psychology and aging, 15*(3), 417.
- Moore, J. W., & Obhi, S. S. (2012). Intentional binding and the sense of agency: a review. *Consciousness and Cognition, 21*(1), 546-561.
- Moore, J. W., & Fletcher, P. C. (2012). Sense of agency in health and disease: a review of cue integration approaches. *Consciousness and cognition, 21*(1), 59-68.
- Nather, F. C., Bueno, J. L. O., Bigand, E., & Droit-Volet, S. (2011). Time changes with the embodiment of another's body posture. *PLoS One, 6*(5), e19818.
- Obhi, S. S., & Hall, P. (2011). Sense of agency in joint action: Influence of human and computer co-actors. *Experimental brain research, 211*(3-4), 663-670.
- Pashler, H. (1994). Dual-task interference in simple tasks: data and theory. *Psychological bulletin, 116*(2), 220.
- Poonian, S. K., & Cunnington, R. (2013). Intentional binding in self-made and observed actions. *Experimental Brain Research, 229*(3), 419-427. doi: 10.1007/s00221-013-

- Poonian, S. K., McFadyen, J., Ogden, J., & Cunnington, R. (2015). Implicit agency in observed actions: evidence for N1 suppression of tones caused by self-made and observed actions. *Journal of cognitive neuroscience*, *27*(4), 752-764.
- Sidarus, N. & Haggard, P. (2016). Difficult action decisions reduce the sense of agency: A study using the Eriksen flanker task. *Acta Psychologica*, *166*, 1-11.
- Simmons, J. P., Nelson, L. D., & Simonsohn, U. (2012). *A 21 word solution*. SSRN eLibrary. Retrieved from [http://papers.ssrn.com/sol3/papers.cfm?abstract\\_id=2160588](http://papers.ssrn.com/sol3/papers.cfm?abstract_id=2160588)
- Sternberg, S. (1966). High-speed scanning in human memory. *Science*, *153*(3736), 652-654.
- Sugovic, M., & Witt, J. K. (2013). An older view on distance perception: older adults perceive walkable extents as farther. *Experimental Brain Research*, *226*(3), 383-391. doi: 10.1007/s00221-013-3447-y
- Synofzik, M., Thier, P., Leube, D. T., Schlotterbeck, P., & Lindner, A. (2010). Misattributions of agency in schizophrenia are based on imprecise predictions about the sensory consequences of one's actions. *Brain*, *133*(Pt 1), 262-271. doi: 10.1093/brain/awp291
- Synofzik, M., Vosgerau, G., & Lindner, A. (2009). Me or not me--an optimal integration of agency cues? *Consciousness and Cognition*, *18*(4), 1065-1068. doi: 10.1016/j.concog.2009.07.007
- Synofzik, M., Vosgerau, G., & Voss, M. (2013). The experience of agency: an interplay between prediction and postdiction. *Frontiers in Psychology*, *4*, 127. doi: 10.3389/fpsyg.2013.00127
- Treisman, M. (1963). Temporal discrimination and the indifference interval: Implications for a model of the "internal clock". *Psychological Monographs: General and Applied*, *77*(13), 1.
- Vierkant, T. (2014). Mental muscles and the extended will. *Topoi*, *33*(1), 57-65.

- Wearden, J. H., Pilkington, R., & Carter, E. (1999). 'Subjective lengthening' during repeated testing of a simple temporal discrimination. *Behavioural Processes*, 46(1), 25-38.
- Wegner, D. M., Sparrow, B., & Winerman, L. (2004). Vicarious agency: Experiencing control over the movements of others. *Journal of Personality and Social Psychology*, 86(6), 838-848. doi: 10.1037/0022-3514.86.6.838
- Wegner, D. M., & Wheatley, T. (1999). Apparent mental causation: Sources of the experience of will. *American psychologist*, 54(7), 480.
- Wenke, D., & Haggard, P. (2009). How voluntary actions modulate time perception. *Experimental brain research*, 196(3), 311-318.
- Witt, J. K., Proffitt, D. R., & Epstein, W. (2004). Perceiving distance: A role of effort and intent. *Perception*, 33, 577-590.
- Woollacott, M., & Shumway-Cook, A. (2002). Attention and the control of posture and gait: a review of an emerging area of research. *Gait & posture*, 16(1), 1-14.
- Yoshie, M., & Haggard, P. (2013). Negative emotional outcomes attenuate sense of agency over voluntary actions. *Current Biology*, 23(20), 2028-2032. doi: 10.1016/j.cub.2013.08.034

### Figure Captions

**Figure 1.** Procedure for the Interval Reproduction task. In each condition the first event consisted of either a key press (“Agency”) or a tone (“No Agency”). After a randomised stimulus interval (500-1500ms) the outcome, a tone, was presented. Participants were prompted to respond by recreating the interval between the first and second events with the depression of the spacebar.

**Figure 2.** Effort manipulation set-up. Participants held the exercise band in their right hand for task-related physical effort (A), and in their left hand for task-unrelated physical effort (B).

**Figure 3.** Mean reproduction errors across factors “Presence of Agency” and “Effort” for each Experiment. Bars extending below the x-axis reflect an underestimation of the stimulus interval (temporal binding). Error bars represent the standard error of the mean for within-subject designs calculated using the procedure recommended by Loftus & Masson (1994). Asterisks indicate significant contrasts at  $p < .05$ .

**Figure 4.** The relationship between “Effort Rating Difference” and “Reproduction Error Differential”. As “Effort Rating Difference” increases “Reproduction Error Differential” increases. Cases with reproduction error differential values above zero are individuals who showed stronger effects of agency (vs. no agency) in low than high effort conditions.

**Figure 5.** Procedure for Experiment 3: Participants were presented with a string of letters, either two (“Low” effort) or eight (“High” effort), after which the Interval Reproduction task started. The first event consisted of either a spacebar press (“Agency”) or a tone (“No Agency”). After a randomised stimulus interval (500-1500ms) the outcome, a tone, was presented. Participants were prompted to make response intervals by recreating the interval between the first event and outcome with the depression of the spacebar, after which

the probe letter appeared, prompting participants to respond as to whether it had appeared in the string at the encoding stage.



Figure 1.

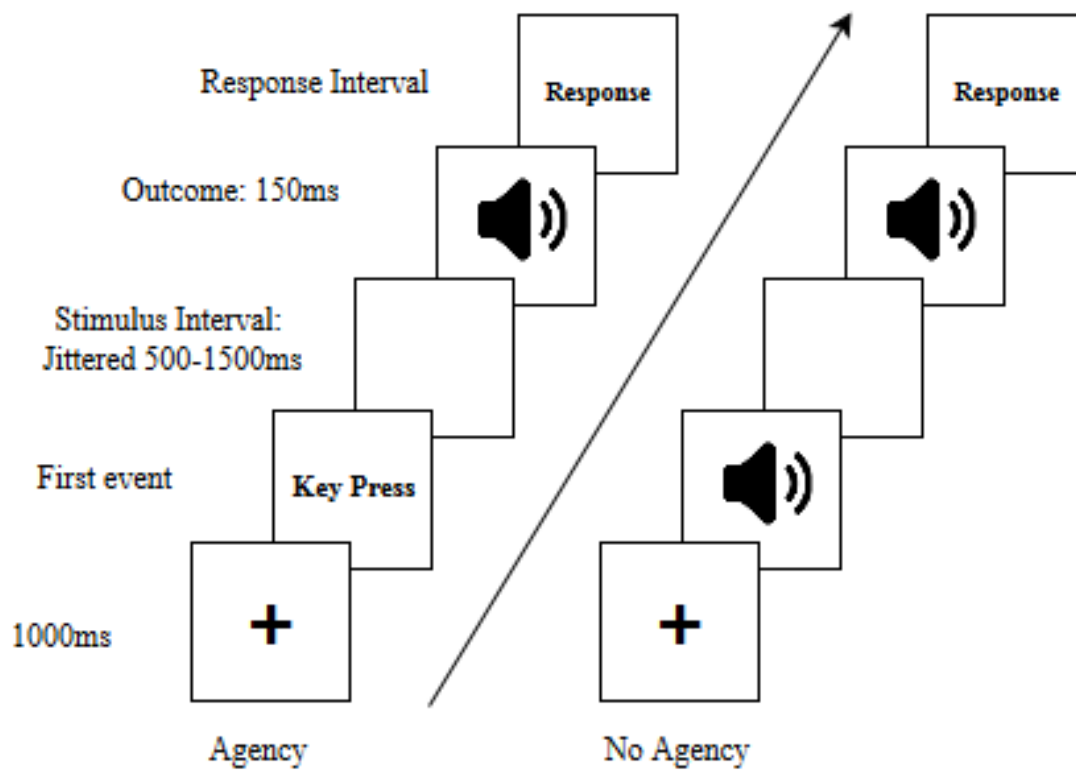
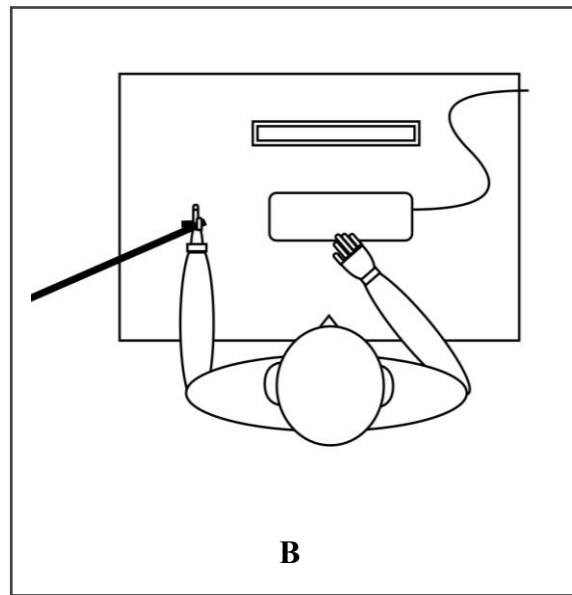
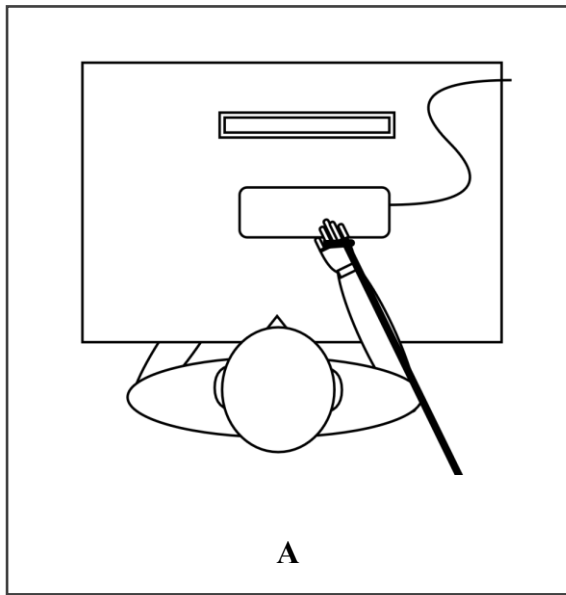
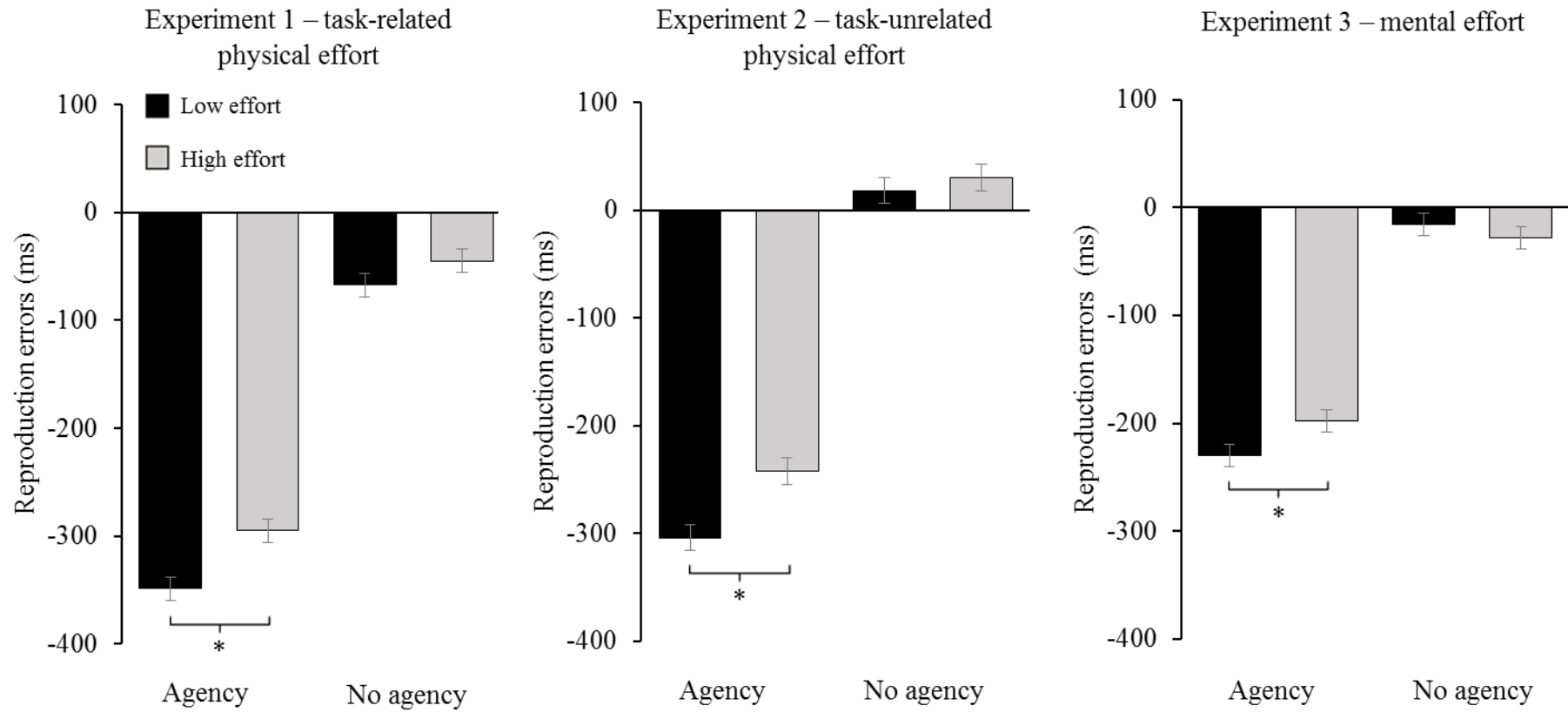

Figure 2.



**Figure 3.**



**Figure 4.**

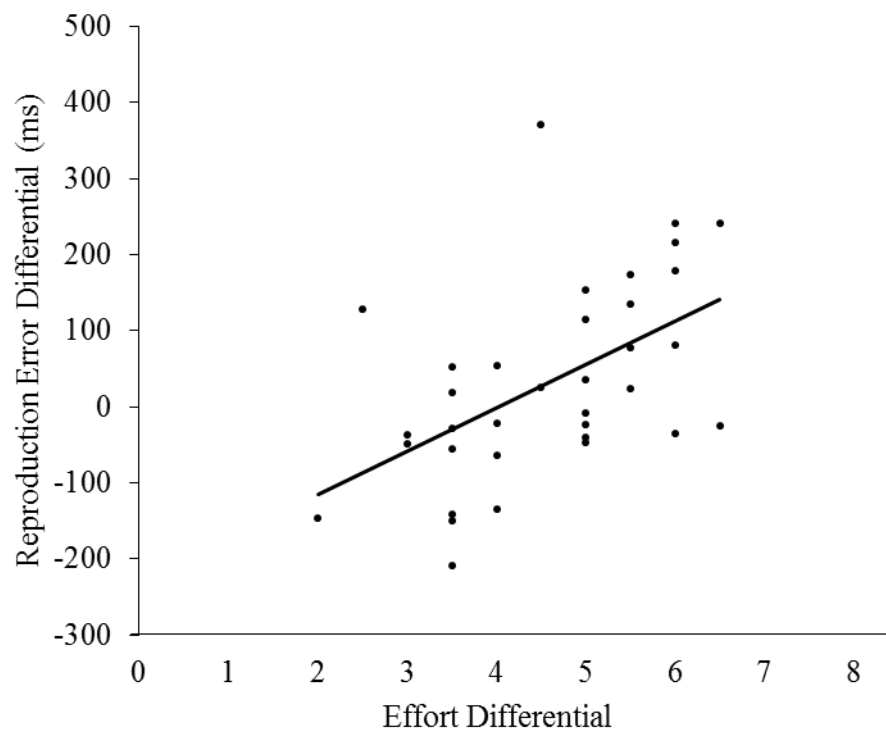

Figure 5.

