

# Modelling the delivery of low carbon energy service in residential buildings

Erica Clare Marshall

Submitted in accordance with the requirements for the degree of

Doctor of Philosophy

as part of the Integrated PhD/MSc in Low Carbon Technologies

The University of Leeds

School of Chemical and Process Engineering

October 2016

The candidate confirms that the work submitted is his/her own and that appropriate credit has been given where reference has been made to the work of others.

This copy has been supplied on the understanding that it is copyright material and that no quotation from the thesis may be published without proper acknowledgement

© 2016 The University of Leeds and Erica Clare Marshall

The right of Erica Clare Marshall to be identified as Author of this work has been asserted by her in accordance with the Copyright, Designs and Patents Act 1988.

# Abstract

The UK is facing a retrofit challenge due to its legacy of old homes which are poorly suited to modern expectations of indoor thermal comfort. The housing stock accounts for almost a third of total energy use and is responsible for significant CO<sub>2</sub> emissions. There is global recognition that the current rate of greenhouse gas emissions is causing long term damage and that changes are required in all sectors in order to limit the impacts of our generation on the global climate. The energy service concept offers an alternative perspective on the energy system. It reframes our demand for energy as a desire for the service which it can provide, such as comfortable homes, illuminated spaces, warm meals and security.

This thesis is an investigation of how energy efficiency technologies and measures can deliver energy services with a lower energy input and uses building modelling software as a tool to do so. Four approaches to improving energy service efficiency are compared, and these are high efficiency conversion device, improved passive system, more accurate service control and a reduced service level. These energy efficiency measures are compared based on energy savings attainable and the efficacy of energy service delivery, using the example service of heating thermal comfort. In recognition of the large influence that household occupants have on energy consumption, household behaviours are included in the analysis. Household occupancy pattern is used to define the service demanded and thus energy efficiency measures are compared for a working family, working couple and daytime-present couple occupancy pattern. The suitability of measures for different households is addressed according to elements of motivation for energy efficiency improvement and technical skills of the occupants.

The results of this work show that improved passive system performed best in both energy savings and heating thermal comfort delivery for all occupancy patterns. However, combinations of lower cost measures of control and service level demonstrate an ability to deliver comparable energy savings for occupancy patterns of working couple and daytime-present couple. The findings of this thesis confirm the importance of improving the thermal performance of the housing stock, but also that increased adoption of heating controls and a readdressing of expectations of service level can deliver significant energy savings. The modelling of the delivery of thermal comfort requires an enhanced modelling approach, but offers the ability for energy efficiency recommendations to be made based on suitability for the household, which will lead to greater energy savings within the domestic sector.

# Acknowledgements

Researching and writing a PhD thesis is a long process have helped significantly along the way, both in contributing to the research and helping me develop as a researcher, and supporting me personally through the process.

First, I would like to thank my supervisors, Julia Steinberger, Tim Foxon and Valerie Dupont for their guidance and support. I am also grateful to Dr Ben Hughes, originally at the University of Leeds and now at the University of Sheffield, for welcoming me as an honorary member of his building physics research group, giving me guidance on some of the building modelling aspects of my work and providing me access to TRNSYS software.

I would like to thank the Low Carbon Technologies Doctoral Training Centre (DTC) for giving me the opportunity to undertake this PhD including all of the additional opportunities such as a placement with the British Gas Energy Performance Contracting Team and funding for conferences. These additional aspects have really enabled me to more greatly understand the context of my work and to meet some inspirational people.

I would of course like to thank everyone on the Low Carbon Technologies DTC for their friendship and company, who have certainly made the past 4+ years a much more enjoyable experience than PhDs often can be. I think it safest not to name specific people, but for her continual friendship, support and wisdom these past few months at the hardest point in the PhD, I am utterly grateful to (soon to be Dr) Clare Linton.

Beyond the Leeds Low Carbon Technologies DTC, I am grateful to have had the opportunity to be involved in the London-Loughborough (LoLo) CDT in Energy Demand, through attending their colloquiums and meeting people at events. Many of the projects have been somewhat more relevant to my project than those on my own DTC and it has been very useful to make these links through the CDT Energy Network. In particular, I'd like to thank Arash Beizae for his excellent work on heating controls and for sharing his published data with me which has been fundamental to my section 6.4.

I would like to thank my family and friends for their continual support, especially my Dad, Steve, for first planting the idea of doing a PhD in my head (and for proof reading the final product!) To all my inspirational doctor friends, you've shown me that reaching the end of the PhD is possible! Thank you also to Danny for being there beside me the past 2+ years, sharing our PhD highs and lows.

A PhD is a long process, and much has happened since it began, particularly so in the past year. The motivation for this project has foremost been as a contribution to efforts to tackle climate change, which is a long term phenomenon building up over generations and with impacts for generations to come. Over the past year, the continual passage of human life has been very present to me, in the saddest and happiest of ways. I would like to dedicate this thesis to those we've lost and to those we've welcomed in the past 18 months. To Martin, who would always greet me "how's the PhD going, sister?", and whose heart gave in on a bike ride, doing what he loved. To Harry, my 'silly uncle'. To Hilary, who won the battle against anorexia but sadly died far too young. To Sebastian, who was a perfect example of how an academic should be. And of course to Andy, who brought such a sense of fun to us all on this PhD journey. I would like to dedicate this thesis to Max, Ellis, Finn, Jim, Jacob, Meriasek, Alice and James. I hope through our generation and theirs, we can save the dignity of the human race.

# Publications

Some of the work within this thesis has been featured in the following publications.

The original work contained within these papers is all the candidate's own work, with co-authors providing guidance and an editorial contribution

Chapter 5 is based on work published in

Marshall, E.C., Steinberger, J.K., Dupont, V. & Foxon, T.J., 2015. Combining Energy Efficiency Measure Approaches and Occupancy Patterns in Building Modelling in the UK Residential Context. *Energy and Buildings*, 111, pp.98–108.

Chapter 6 develops upon work published in

Marshall, E.C., Steinberger, J.K., Foxon, T.J. & Dupont, V., 2016. Modelling the delivery of residential thermal comfort and energy savings: comparing how occupancy type affects the success of energy efficiency measures. In Dastbaz, M. & Gorse, C., eds. *Selected Proceedings from the International Conference of Sustainable Ecological Engineering Design for Society (SEEDS)*. Springer.

During the course of this PhD, the following papers and posters have been presented at conferences.

Marshall, E.C., Foxon, T., Steinberger, J. & Dupont, V., 2015. Beyond fabric : how heating practices can be incorporated into domestic energy modelling. In *ECEEE Summer Study proceedings 2015*. pp. 2209–2215.

Marshall, E.C., 2013. From Well to Welfare: an 'Energy Services' Perspective for Energy Use in Buildings (Poster presentation). *LoLo Conference 2013: Saving energy in buildings: Why does Context Matter?* London, UK (22nd Nov 2013)

Marshall, E., Steinberger, J.K., Foxon, T.J. & Dupont, V., 2013. A Review of the Concept of Energy Service Efficiency as a Metric for Assessing the Provision of Energy Services in Residential Buildings. In *7th International Conference on Energy Efficiency in Domestic Appliances and Lighting (EEDAL'13)*. Coimbra, Portugal.

Marshall, E., Steinberger, J.K., Foxon, T.J. & Dupont, V., 2013. Addressing the Concept of Energy Service Efficiency for Providing Residential Energy Services in a Transition to More Sustainable Cities. In *International Symposium on Modelling Sustainable Urban Transition Dynamics*. Cardiff, UK.

# Table of Contents

<b>CHAPTER 1 INTRODUCTION .....</b>	<b>19</b>
1.1. MOTIVATION: ENERGY USE, CLIMATE CHANGE AND THE RETROFIT CHALLENGE .	19
1.2. CONTEXT: ENERGY EFFICIENCY AND THE ENERGY SERVICE CONCEPT .....	20
1.3. FOCUS OF THESIS.....	23
1.4. THESIS STRUCTURE .....	24
<b>CHAPTER 2 LITERATURE REVIEW .....</b>	<b>27</b>
2.1. INTRODUCTION .....	27
2.2. ENERGY SERVICES THEORY .....	28
2.3. HOUSEHOLD OCCUPANTS .....	44
2.4. DOMESTIC RETROFIT .....	61
2.5. BUILDING MODELLING.....	71
2.6. CONCLUSION .....	77
<b>CHAPTER 3 RESEARCH FRAMEWORK .....</b>	<b>81</b>
3.1. METHODOLOGY DEVELOPMENT .....	81
3.2. ANALYTIC FRAMEWORK.....	88
<b>CHAPTER 4 INVESTIGATION OF SERVICE UNIT OF HEATING THERMAL COMFORT .....</b>	<b>93</b>
4.1. INTRODUCTION .....	93
4.2. IDENTIFICATION OF ENERGY SERVICE EFFICIENCY METRICS.....	94
4.3. IDENTIFICATION OF TECHNOLOGIES .....	97
4.4. BUILDING MODELLING: QUASI STEADY STATE .....	100
4.5. EXPLORATION OF ENERGY SERVICE METRICS .....	107
4.6. DISCUSSION .....	128
4.7. CONCLUSION .....	130

<b>CHAPTER 5 ENERGY SAVINGS FOR ENERGY SERVICE DEFINED BY OCCUPANCY PATTERN.....</b>	<b>131</b>
5.1. INTRODUCTION .....	131
5.2. DEVELOPMENT OF BUILDING MODEL .....	132
5.3. SERVICE DEMAND.....	136
5.4. TECHNOLOGIES AND EEMs.....	137
5.5. CALCULATION OF ENERGY SAVINGS ACHIEVABLE WITH THE IMPLEMENTATION OF EEMs .....	151
5.6. RESULTS VALIDATION AND SENSITIVITY ANALYSIS.....	156
5.7. DISCUSSION .....	162
5.8. CONCLUSION.....	167
<b>CHAPTER 6 MODELLING SERVICE DELIVERY OF HEATING THERMAL COMFORT .....</b>	<b>169</b>
6.1. INTRODUCTION .....	169
6.2. MEASUREMENT OF SERVICE DELIVERY .....	170
6.3. ENERGY EFFICIENCY TECHNOLOGIES AND MEASURES.....	174
6.4. BUILDING MODELLING .....	176
6.5. RESULTS.....	179
6.6. DISCUSSION .....	197
6.7. CONCLUSION.....	203
<b>CHAPTER 7 DISCUSSION .....</b>	<b>205</b>
7.1. INTRODUCTION .....	205
7.2. TECHNOLOGY ASSESSMENT .....	205
7.3. ENERGY SERVICE THEORY .....	214
7.4. BUILDING MODELLING .....	221



<b>CHAPTER 8 CONCLUSION .....</b>	<b>227</b>
8.1. FULFILMENT OF RESEARCH QUESTIONS .....	227
8.2. POLICY RECOMMENDATIONS.....	233
8.3. RECOMMENDATIONS FOR FUTURE WORK .....	236
8.4. FINAL REMARKS.....	238
<b>REFERENCES .....</b>	<b>239</b>
<b>LIST OF FIGURES .....</b>	<b>10</b>
<b>LIST OF TABLES.....</b>	<b>13</b>
<b>NOMENCLATURE .....</b>	<b>15</b>
<b>APPENDIX</b>	
APPENDIX A EMBODIED ENERGY CALCULATIONS FOR CHAPTER 4 .....	253
A.2 Derivation of values for embodied energy and carbon .....	253
APPENDIX B BUILDING MODEL DEVELOPMENT FOR CHAPTER 5.....	255
B.1 Outline of modelling process.....	255
B.2 Model values for investigation of savings from individual technologies used in Chapter 5 .....	260
APPENDIX C MODEL VALIDATION FOR CHAPTER 5 .....	261
C.1 Statistical validation .....	261
C.2 Sensitivity Analysis .....	268
C.3 Rebound Effect.....	270
APPENDIX D BUILDING MODEL DEVELOPMENT FOR CHAPTER 6.....	271
D.1 Description of enhanced building energy model methodology .....	271
D.2 Comparison of modelled and measured temperature profile.....	275
D.3 Comparison of heating demand calculations between building model approaches.... .....	277

# List of figures

<b>Figure 1-1</b> Illustration of analytic framework .....	23
<b>Figure 2-1</b> Energy system chain (created by author, adapted from various sources (Cullen & Allwood 2010a; Nørgård 2000; Jonsson et al. 2011; dos Santos et al. 2013; Jochem 2000; Nakićenović 1993)). The image of the house shows the split between on and off site stages, in this case suggesting the example of domestic energy services.....	30
<b>Figure 2-2</b> Illustration of heating degree-days calculation .....	72
<b>Figure 3-1</b> Illustration of heat management approaches.....	84
<b>Figure 3-2</b> Thesis analytic framework diagram showing interlinking aspects of energy service delivery, energy efficiency technologies and building modelling.....	88
<b>Figure 4-1</b> Comparison of how thickness of insulation affects the U-value of a wall. Three types of insulation are shown which have different values of thermal conductivity ( $k$ ). ExPS: Expanded Polystyrene; PUR: Polyurethane Insulation Foam; MW: Mineral wool. ExPS is most commonly used in solid wall insulation .....	99
<b>Figure 4-2</b> Schematic to show the heat transfer ( $Q$ [W]) and surface area ( $A$ [ $m^2$ ]) of the interfaces between heated and heated areas ( $h$ - $uh$ ), heated areas and outside ( $h$ - $o$ ) and under-heated areas and outside ( $uh$ - $o$ ). Temperatures ( $T$ [ $^{\circ}C$ ]) for the heated area ( $h$ ), under-heated area ( $uh$ ) and outside ( $o$ ) are also shown. ....	103
<b>Figure 4-3</b> Energy demand for different technology approaches to delivering a service unit of warm occupied spaces at 21 $^{\circ}C$ for one day. Energy input is distinguished between operational energy and embodied energy in the technology .....	114
<b>Figure 4-4</b> Carbon Dioxide emissions resulting from delivery of a service unit of a warm occupied room at 21 $^{\circ}C$ for one day for different technology approaches. ....	114
<b>Figure 4-5</b> Energy demand for different technology approaches to delivering a service unit of a warm occupied room for one day for (a) different house types where floor areas are Detached: 147 $m^2$ , Semi-detached: 93 $m^2$ , Mid-terraced: 80 $m^2$ (demand temperature 21 $^{\circ}C$ ); (b) different demand temperature (modelled house is detached house, floor area 98 $m^2$ ). ....	115
<b>Figure 4-6</b> Heating energy demand savings for improved boiler efficiency including different values of initial boiler efficiency .....	120
<b>Figure 4-7</b> Comparison of how thickness of insulation affects the savings on energy loss (including infiltration of 0.7 ach). Three types of insulation are shown which have different values of thermal conductivity ( $k$ ). ExPS: Expanded Polystyrene; PUR: Polyurethane .....	120
<b>Figure 4-8</b> Energy savings attainable for additional thicknesses of insulation, including effect of (a) proportion of insulation cover (to allow for effects such as thermal bridging, (b) type of house, (c) effect of initial level of insulation, and (d) infiltration rate. ....	123
<b>Figure 4-9</b> Energy savings attainable for temperature set-point decrease. Different lines show effect of initial internal temperature and average external temperature. ....	125

<b>Figure 4-10</b> Influence of proportion of house which is under-heated on the energy savings at difference values of internal temperature of under-heated space.....	126
<b>Figure 4-11</b> Energy savings for partial heating as a function of U-value of external and internal walls. Plots show energy savings for (a) 50 % under-heated floor area, under-heated temperature of 14 °C, (b) 30 % under-heated floor area, under-heated temperature of 16 °C, (c) 30 % under-heated floor area, under-heated temperature of 14 °C.....	127
<b>Figure 4-12</b> Range of savings attainable with heat management options .....	128
<b>Figure 5-1</b> Building modelling process.....	133
<b>Figure 5-2</b> Plan of modelled house .....	134
<b>Figure 5-3</b> Ideal temperature profiles in different rooms for each of the three occupancy patterns. Shaded area shows baseline heating control using programmable timer thermostat (some temperature profiles have been off-set for greater visual clarity).....	137
<b>Figure 5-4</b> Calculated values of heating energy demand for a range of base level thermal resistance and improvements. Numbers in square brackets refer to indication of thermal resistance level in Table 5-5, corresponding to wall, window, roof and infiltration standard .....	141
<b>Figure 5-5</b> Annual heating energy demand calculated for range of heating control options (based on a working family occupancy pattern).....	145
<b>Figure 5-6</b> Annual heating energy demand calculated for range of internal temperature set-points .	146
<b>Figure 5-7</b> Modelled values of energy demand for heating values for a range of single and combinations of energy efficiency measures. EEMs are given in Key in Table 5-15. Values are calculated for three occupancy patterns which represent (a) working family, (b) working couple, and (c) daytime-present couple. Shaded out bars in (a) are those which do not apply .....	152
<b>Figure 5-8</b> Modelled energy savings for single and combinations of energy efficiency measures for three occupancy patterns. EEMs are given in Key in Table 5-15.....	154
<b>Figure 5-9</b> Normalised sensitivity parameter comparison of EEMs for working couple and daytime-present couple occupancy patterns.....	160
<b>Figure 5-10</b> Range of modelled energy savings for single and combinations of energy efficiency measures representing the uncertainty of energy savings if occupancy pattern is unknown. EEMs letters are explained in the Key in Table 5-15 .....	167
<b>Figure 6-1</b> Comparison temperature profile plots showing (a) extended time period, (b) time averaged day profile. EEM scenarios are explained in Table 6-1.....	172
<b>Figure 6-2</b> Illustration of the calculation of the Heating comfort Gap (HCG) .....	174
<b>Figure 6-3</b> Comparison of modelled temperature by typical heat balance building model used in Chapter 5 and measured temperature profile in real living room, taken from empirical work by Beizae et al (2015) (Figure 5 therein).....	176
<b>Figure 6-4</b> Comparison of modelled temperature profiles between heat balance model (as used in chapter 5), enhanced model (as used in this chapter) and measured data (taken from empirical work by Beizae et al (2015) (Fig 5 therein)).....	179
<b>Figure 6-5</b> Average temperatures and average heated temperatures for Working Family occupancy pattern across the range of energy efficiency measures. (Notation: Tbar refers to T).....	180
<b>Figure 6-6</b> Average temperatures and average heated temperatures for Working Couple occupancy pattern across the range of energy efficiency measures. (Notation: Tbar refers to T).....	181

<b>Figure 6-7</b> Average temperatures and average heated temperatures for Daytime-present Couple occupancy pattern across the range of energy efficiency measures. (Notation: $T_{bar}$ refers to T) .....	182
<b>Figure 6-8</b> Weighted average comparison of working family occupancy pattern. (Notation: $T_{bar}$ refers to T).....	184
<b>Figure 6-9</b> Averaged daily temperature profile (averaged on each time step over a 30-day period) for Working Family occupancy pattern showing full range of EEM scenarios (HC: heating control) for (a) Living room internal temperature, and (b) Bedroom internal temperature .....	186
<b>Figure 6-10</b> Averaged daily temperature profile (averaged on each time step over a 30-day period) for Working Couple occupancy pattern showing full range of EEM scenarios (HC: heating control) for (a) Living room internal temperature, and (b) Bedroom internal temperature. Two day period is shown to represent the two daily patterns exhibited by the Working Couple occupancy pattern.....	187
<b>Figure 6-11</b> Averaged daily temperature profile (averaged on each time step over a 30-day period) for Daytime-present Couple occupancy pattern showing full range of EEM scenarios (HC: heating control) for (a) Living room internal temperature, and (b) Bedroom internal temperature ....	188
<b>Figure 6-12</b> Temperature shortfall stacks for living room (LR), bedroom (BR) internal temperatures, and a weighted average of the two modelled rooms (Av) for (a) Working family, (b) Working couple, and (c) Daytime-present couple .....	191
<b>Figure 6-13</b> Heating Comfort Gap factor for each energy efficiency measure shown for living rooms and bedrooms for (a) Working Family, (b) Working Couple, and (c) Daytime-present Couple Occupancy Patterns .....	193
<b>Figure 6-14</b> Heating Comfort Gap vs Heating energy demand scatter chart for full range of EEM scenarios for Working Family occupancy pattern in (a) living room, (b) bedroom, and (c) weighted average .....	194
<b>Figure 6-15</b> Heating Comfort Gap vs Heating energy demand scatter chart for full range of EEM scenarios for Working Couple occupancy pattern in (a) living room, (b) bedroom, and (c) weighted average .....	195
<b>Figure 6-16</b> Heating Comfort Gap vs Heating energy demand scatter chart for full range of EEM scenarios for Daytime-Present Couple occupancy pattern in (a) living room, (b) bedroom, and (c) weighted average.....	196
<b>Figure 6-17</b> Illustration of zones of suitability where the shaded zone represents the EEMs which would be more suitable for (a) a household motivated by comfort or sensitive to temperature, and (b) a household motivated by cost or environmental impact .....	203
<b>Figure. B-1</b> Screen shot TRNSYS3D within GoogleSketchup® for the definition of building geometry .....	255
<b>Figure. B-2</b> Screen shot of TRNSYS Simulation Studio.....	256
<b>Figure. B-3</b> Screen shot of TRNBuild.....	257
<b>Figure. C-1</b> Comparison of total monthly HDDs (year 2012) for four locations against HDDs in Meteoronorm data set .....	264
<b>Figure. C-2</b> Statistical values for annual gas consumption from NEED data-set for regions of East of England, South East and London. Coloured bars represent median values and error bars represent upper and lower quartile.....	265
<b>Figure. C-3</b> House wall types by year of construction for UK houses taken from (DCLG, 2010) ....	265

<b>Figure. C-4</b> Number of properties with solid, cavity wall and loft insulation out of broad sample of UK homes (Taken from (DCLG, 2010)) .....	266
<b>Figure. D-1</b> Screen shot of the TRNSYS Simulation Studio .....	273
<b>Figure. D-2</b> Comparison of temperature profile taken from representative 24 hour period in heat balance model as used in Chapter 5, enhanced model as used in the present chapter and measured data (taken from empirical work by Beizaee et al (2015) (Fig 5 therein)). Profiles are shown for (a) Living room with heating control by heating timer and TRVs (termed 'conventional control' by Beizaee et al.), (b) Bedroom with heating control by heating timer and TRVs, (c) Living room with AZHC (termed 'zonal control' by Beizaee et al.), and (d) Bedroom with AZHC. All figures show difference between time step ( $\delta t$ ) of 3 minutes and 15 minutes. ....	276
<b>Figure. D-3</b> Comparison of heating energy demand calculated in heat balance model (Chapter 5) and enhanced model (present chapter) .....	277

## List of tables

<b>Table 2-1</b> Stages in the Energy Chain .....	31
<b>Table 2-2</b> Reported dwelling and occupant factors which affect energy use .....	46
<b>Table 2-3</b> Review of literature reported 'heating behaviours' .....	53
<b>Table 2-4</b> Household occupancy patterns used in literature.....	54
<b>Table 2-5</b> Household archetypes for energy related behaviour .....	59
<b>Table 2-6</b> Energy efficiency technologies and measures identified in literature (Anastaselos et al. 2009; Ardente et al. 2008; Baetens et al. 2011; Bristol Green Doors 2013; CIBSE 2012; DECC 2012b; Harvey 2010; Lovins 2011; Lowe et al. 2011; Papadopoulos 2005; Pargana 2012; Palmer et al. 2012; Parity 2012; Passive House Institute 2013; Petersdorff et al. 2002) .....	62
<b>Table 3-1</b> Definition of heating thermal comfort energy service using service dimension framework presented by Jonsson (2011; 2005) .....	82
<b>Table 3-2</b> Technologies for delivering thermal comfort derived from literature review .....	85
<b>Table 4-1</b> Examples of units of thermal comfort related service in literature.....	94
<b>Table 4-2</b> Examples of functional units from LCA in literature.....	95
<b>Table 4-3</b> Default values for model parameters.....	106
<b>Table 4-4</b> Values of key parameters before and after intervention for technologies used in modelling for calculating energy per service delivery.....	110
<b>Table 4-5</b> Results of embodied and operational energy and carbon emissions due to the delivery of defined service of a single day of warm occupied space.....	113
<b>Table 4-6</b> Values of key parameters for ideal demand modelling .....	117
<b>Table 4-7</b> Energy efficiency of service delivery using metric of comparison to ideal demand.....	117
<b>Table 4-8</b> Interventions for modelling including lower and upper bound of key parameters.....	119

<b>Table 4-9</b> Calculation of embodied energy of insulation delivering a thermal resistance of 1 ( $m^2K$ )/W (= U-value of 1 W/( $m^2K$ ) .....	121
<b>Table 4-10</b> Calculation of embodied energy per energy saving for insulation .....	122
<b>Table 5-1</b> Description of parts that make up the building modelling process.....	133
<b>Table 5-2</b> Description of modelling variables with justifications for chosen values.....	135
<b>Table 5-3</b> Description of occupancy patterns used in modelling .....	137
<b>Table 5-4</b> Shortlist of technologies for consideration within project.....	138
<b>Table 5-5</b> Explanation of level of thermal resistance for building elements used in model calculations for Figure 5-4.....	140
<b>Table 5-6</b> Wall, roof and window construction used in model.....	142
<b>Table 5-7</b> Heating management options enabled by heating controls.....	143
<b>Table 5-8</b> Examples of heating schedules for different heating control options - illustrative .....	144
<b>Table 5-9</b> Temperature set-points used for heating control profiles in building model (as referred to in Table 5-8 and Table 5-11 .....	147
<b>Table 5-10</b> Temperature set-points throughout house used in initial case and for one or two degree temperature reduction .....	148
<b>Table 5-11</b> Examples of heating schedules for different partial under-heating control options – illustrative. These form a continuation from heating control options as given in Table 5-8. .	149
<b>Table 5-12</b> Barriers to the adoption of EEMs and the level to which they apply .....	150
<b>Table 5-13</b> Outline of combinations of measures investigated in the present work.....	150
<b>Table 5-14</b> Values of energy efficiency measures for before and after the implementation of the intervention.....	151
<b>Table 5-15</b> Key to EEMs (single and combinations) plotted in Figure 5-7 and Figure 5-8.....	153
<b>Table 5-16</b> Energy demand savings calculated for single and combinations of EEMs for three occupancy patterns, ranked and grouped according to level of savings achieved. (Italics are used for combined measures, shaded measures are those which do not apply) .....	155
<b>Table 5-17</b> Comparison between model data and data taken from literature for total energy demand and savings due to EEMs .....	157
<b>Table 5-18</b> Assessment for linearity of normalised sensitivity parameters for EEMs for working couple and daytime-present couple occupancy patterns. Key: BI: Before intervention; AI: after intervention.....	160
<b>Table 5-19</b> Effect of a 1 °C comfort taking rebound effect on calculated savings .....	162
<b>Table 6-1</b> Description of technologies and EEMs .....	175
<b>Table 7-1</b> Application of service technology breakdown to energy services of sustenance and hygiene .....	214
<b>Table 7-2</b> Suitability of EEMs to occupancy factors of technical confidence and priority in energy efficiency improvement. CD: Conversion device; PS: Passive system; SC: Service control; SL: Service level.....	216
<b>Table. A-1</b> Values for calculation of embodied energy and carbon in condensing boiler compared to CHP engine.....	253

<i>Table. A-2 Values for calculation of embodied energy and carbon in condensing boiler compared approximated to equivalent mass of stainless steel</i> .....	253
<i>Table. A-3 Values for calculation of embodied energy and carbon in electric resistance heater compared to equivalent mass of steel (95 %) and nickel (5 %)</i> .....	253
<i>Table. A-4 Calculation of embodied energy of insulation delivering a thermal resistance, Rins of 1.33 (m<sup>2</sup>K)/W</i> .....	254
<i>Table. B-1 Module 'Types' used in TRNSYS building model</i> .....	256
<i>Table. B-2 Description of physical aspects of model</i> .....	258
<i>Table. B-3 Modelling parameters controlled through MATLAB script</i> .....	259
<i>Table. B-4 Values of model parameters used in section 5.4.2 for the calculation of savings from individual technologies</i> .....	260
<i>Table. C-1 Categories of statistical data available in NEED database with indication of choice made for statistical benchmark</i> .....	262
<i>Table. C-2 Total Heating Degree Days (HDDs) for year 2012</i> .....	263
<i>Table. C-3 Average total HDDs and standard deviation for regions within NEED dataset (DECC, 2014d)</i> .....	263
<i>Table. C-4 Derivation of statistical benchmark for post-insulated dwelling (data from (DECC, 2014d)</i> .....	266
<i>Table. C-5 Total UK domestic gas consumption by end-use. Taken from Table 3.02 in (DECC, 2014a)</i> .....	267
<i>Table. C-6 Benchmark values determined for gas consumption for space heating</i> .....	267
<i>Table. C-7 Results of sensitivity analysis for Working Family Occupancy Pattern</i> .....	268
<i>Table. C-8 Results of sensitivity analysis for Daytime-Present Couple Occupancy Pattern</i> .....	269
<i>Table. C-9 Temperature set-points throughout house used in initial case and for a 1 °C comfort taking rebound effect</i> .....	270
<i>Table. D-1 Values of parameters in radiator units TRNSYS building model</i> .....	272
<i>Table. D-2 Values of parameters in thermostat units in TRNSYS building model</i> .....	272
<i>Box 2-1 Description of domestic energy services</i>	
<i>Box 2-2 The rebound effect</i>	
<i>Box 2-3 Degree-day analysis</i>	

## Nomenclature

Symbol	Definition	Unit
$A_f$	Floor area of house	m <sup>2</sup>
$A_s$	Surface area of building envelope	m <sup>2</sup>
$\alpha$	Thermal resistance of wall elements excluding insulation	(m <sup>2</sup> K)/W

$c_p$	Heat capacity	$\text{kJ}/(\text{kgK})$
$\varepsilon$	Number of exposed sides of house (detached = 2, semi-detached = 1, mid terrace = 0)	–
$\eta_{CD}$	Efficiency of conversion device	%
$\gamma_{air}$	Volumetric heat capacity of air	$\text{kJ}/(\text{m}^3\text{K})$
$h_{sf,i}$	Number of hours which have a temperature shortfall between $i\text{ }^\circ\text{C}$ and $i + 1\text{ }^\circ\text{C}$	hr
$h_f$	Height of one floor of house	m
$H$	Humidity of air in house	$\text{kg}/\text{kg}$
$\theta_{uh}$	Proportion of house under-heated	-
$\dot{I}_{ach}$	Infiltration rate of air	ach
$\dot{I}_{air}$	Infiltration rate of air	$\text{m}^3/\text{s}$
$k$	Thermal conduction of layer of building envelope	$(\text{mK})/\text{W}$
$n_f$	Number of floors of house	–
$\omega$	Thickness of layer of building envelope	m
$\varphi_{ls}$	Ratio of length to width of house (shape descriptor)	–
$Q$	Heat energy	J or kWh
$\dot{Q}$	Power, rate of energy transfer	W
$Q_{demand}$	Energy demand (calculated)	kWh
$Q_{final}$	Final energy (delivered to house)	kWh
$\dot{Q}_{loss}$	Rate of energy loss	kW
$\dot{Q}_{max}$	Maximum heating rate	W
$\dot{Q}_{rise}$	Rate of heating required to increase internal temperature	W
$\dot{Q}_{sust}$	Rate of heating required to maintain equilibrium temperature	W
$n_{\delta t}$	Number of time steps in simulation	-
$n_d$	Number of days in simulation	-
$n_f$	Number of floors in house	-
$n_{uh}$	Number of under-heated areas	-
$R_{si}$	Thermal surface resistance of internal surface	$(\text{m}^2\text{K})/\text{W}$
$R_{so}$	Thermal surface resistance of external surface	$(\text{m}^2\text{K})/\text{W}$
$c_p$	Heat capacity	$\text{kJ}/(\text{kgK})$
$T$	Temperature	$^\circ\text{C}$
$T_{cold}$	Temperature of space before heating	$^\circ\text{C}$
$T_{dem}$	Temperature demand	$^\circ\text{C}$



$T_{ext}$	External temperature	°C
$T_{int}$	Calculated internal temperature	°C
$T_{set}$	Set-point temperature of heated space	°C
$T_{set,min,j}$	Minimum set-point temperature of room $j$	°C
$T_{uh}$	Temperature of under-heated space	°C
$T'_{int}$	Dummy calculated internal temperature	°C
$\bar{T}$	Average temperature	°C
$\bar{T}_{24hr}$	Average temperature, over all time of simulation	°C
$\bar{T}_{occ}$	Average temperature, only occupied periods	°C
$t$	time	s, hr
$\tau_{heat}$	Length of heating period	s, hr
$\tau_{rise}$	Time taken to reach set-point temperature	s
$\tau_{sim}$	Total simulation length	s, hr
$t_{start,k}$	Time at which occupied period $k$ begins	hr
$t_{end,k}$	Time at which occupied period $k$ ends	hr
$\delta t$	Length of each simulation time step	s
$U_{ext}$	Thermal transmittance of external building envelope	W/(m <sup>2</sup> K)
$V_h$	Heated volume	m <sup>3</sup>
<b>AZHC</b>	Advanced zonal heating control	
<b>BEM</b>	Building energy model	
<b>BRE</b>	Building Research Establishment	
<b>BREDEM</b>	Building Research Establishment Domestic Energy Model	
<b>CERT</b>	Carbon Emission Reduction Target	
<b>CESP</b>	Community Energy Saving Programme	
<b>CFD</b>	Computational fluid dynamics	
<b>CHP</b>	Combined heat and power	
<b>CIBSE</b>	Chartered Institute of Building Services Engineers	
<b>DCLG</b>	(UK Government) Department for Communities and Local Government	
<b>DECC</b>	(UK Government) Department of Energy and Climate Change	
<b>DESCo</b>	Domestic energy service company	
<b>DIY</b>	Do-it-yourself	

<b>DPC</b>	Daytime-present couple
<b>EC</b>	Embodied carbon
<b>ECO</b>	Energy Company Obligation
<b>EDS</b>	Energy distribution system
<b>EE</b>	Embodied energy
<b>EEID</b>	Energy efficiency compared to ideal demand
<b>EEM</b>	Energy efficiency measure
<b>EPC</b>	Energy Performance Certificate
<b>EPS</b>	Energy production system
<b>ESCo</b>	Energy service company
<b>ESEI</b>	Energy service energy intensity
<b>ESES</b>	Energy saving compared to existing situation
<b>EUS</b>	Energy usage system
<b>ExPS</b>	Expanded polystyrene (insulation)
<b>HAS</b>	Human activity system
<b>HC</b>	Heating control
<b>HCG</b>	Heating comfort gap
<b>HTC</b>	Heating thermal comfort
<b>HVAC</b>	Heating, ventilation and air-conditioning
<b>LCA</b>	Life cycle assessment
<b>MW</b>	Mineral wool (insulation)
<b>PBEE</b>	Performance based energy economy
<b>PMV</b>	Predicted mean vote
<b>PPD</b>	Percentage person dissatisfied
<b>PUR</b>	Polyurethane Insulation Foam
<b>SAP</b>	Standard Assessment Procedure
<b>SPT</b>	Social practice theory
<b>TRV</b>	Thermostatic radiator valve
<b>WC</b>	Working couple
<b>WF</b>	Working family

# Chapter 1 Introduction

## 1.1. Motivation: energy use, climate change and the retrofit challenge

In the late eighteenth century, with the discovery of the steam engine, an industrial revolution began which was to change how societies functioned and the pace at which progress could be made. Coal, oil and gas became feed-stocks to this vast industrial system. Huge benefits were gained; people could travel further, could work faster, and with a vast increase in average income, standard of living increased steadily. With the invention of electricity generation and distribution, people could achieve things that had never before been conceived of, including better healthcare options and long distance travel, whilst computers and the internet paved the way for the digital revolution. All this progress came with a cost, and by the mid twentieth century, pollution levels in cities had reached high levels; buildings turned black and people's health was threatened by rising cases of respiratory diseases. In the 1970s, people started to become aware of a wider danger of the unabated burning of fossil fuels. Global warming was threatening to change the climate, due to the mass release of carbon dioxide from carbon reserves which had been stored underground for millennia. This posed the threat of catastrophic effects for the biosphere, and the human population which had come to rely on it. Since the 1970s, understanding of the threat of climate change has grown, leading to a strengthened awareness that we need to relinquish our reliance on fossil fuels as a feedstock to society. However, overcoming our addiction to limitless and cheaply available energy is a defining challenge of our generation.

In the UK, domestic energy consumption accounts for around a third of total energy use (DECC 2014b), and of this, 60 % is attributable to space heating (Palmer & Cooper 2013). It is forecasted that a majority (figures vary between 70 % and 80 %) of buildings which will exist in 2050 have already been built (Power 2008; Ravetz 2008; Johnston et al. 2005), and that of these, 40 % will have been built prior to 1985 and therefore pre-date the introduction

of energy efficiency requirements within building standards (part L) (Rhoads et al. 2010; Stafford et al. 2011). In order to meet the legally binding economy wide targets for a 80 % reduction in greenhouse gases by 2050, the building sector is targeted to achieve zero carbon emissions given the limited scope for reducing emissions in some other sectors (UK Government 2008; CCC 2010). Pressures to improve the energy efficiency of homes also come from trying to address high levels of fuel poverty and concerns over energy security. A significant challenge therefore exists to improve the energy performance of existing buildings through energy efficiency retrofit<sup>1</sup>.

Rudge (2012) attributed the UK's poor quality housing stock to the UK's mild climate and the availability of coal during the period of industrialisation. The availability of coal led to the use of open fires which required high ventilation rates and hence the leaky building envelopes of older housing today. A mild and changeable climate and low indoor temperature expectation led to low priority given to energy efficiency in housing legislation, and economic priorities led to poor quality mass housing being produced. Solid wall houses account for 7.5 million dwellings across the UK (Dowson et al. 2012), and this legacy of 'hard-to-treat' houses poses an even greater challenge for retrofit as solid walls are more complicated than cavity wall construction to insulate, and problems of damp can often be caused if ventilation is not adequately addressed (Hansford 2015).

## **1.2. Context: energy efficiency and the energy service concept**

The UK coalition government identified improving energy efficiency as 'a key strategic objective' in its 2012 Energy Efficiency Strategy (DECC 2012a) and the International Energy Agency (IEA) recommended it as the 'largest and least costly strategy' for realising reductions in carbon emissions (IEA 2008 in; Cullen & Allwood 2010a). It is said to offer the possibility to reduce energy use by 'using only the energy we really need' (DECC 2012a), lessening CO<sub>2</sub> emissions which are contributing to climate change and aiding security of supply.

---

<sup>1</sup> Retrofit in this thesis is defined as energy efficiency motivated renovation or adoption of technologies

## 1.2. Context: energy efficiency and the energy service concept

The term 'energy efficiency' is 'widely used but not always well understood' (Sorrell et al. 2011). Patterson (1996) wrote that energy efficiency is a 'generic term', and there is a need for greater attention to be given to 'defining and measuring the concept' in response to the then 'surprisingly little serious attention' it was being given despite its central focus in national energy policies. In the engineering field, energy efficiency is generally defined by the ratio of useful output of a process to energy input into the process (Patterson 1996; Pérez-Lombard, Ortiz, Maestre, et al. 2012). A similar metric is energy intensity, or specific energy consumption, which is the inverse of efficiency and represents the input of energy required to achieve a useful output.

These metrics are related to the first law of thermodynamics, that within a closed system, energy is conserved. Energy efficiency in this form shows the proportion of energy input which is converted to the desired output. In some cases, full conversion between useful energy forms is possible and energy efficiency can tend to unity. In other cases, there exist physical limits to the extent of efficiency conversion and therefore the maximum, or ideal, efficiency is less than 1; an example of this is the Betz limit for harnessing kinetic energy from the wind whereby the maximum efficiency of an ideal wind turbine cannot exceed 0.593 (Sorensen 2004). Efficiency can exceed 1 in cases where an energy input enables energy to be harnessed from the environment and in these cases the term coefficient of performance is favoured over efficiency; heat pumps are an example of a system which has a coefficient of performance greater than unity, whereby electrical energy input returns more than an equal quantity of heat energy output.

The output of an energy use system may be a measure of energy, a measure of 'quantity of service' (such as mass of product, unit area of floor area or passenger-kilometre) or an economic variable such as Gross Domestic Product (GDP); Patterson (1996) termed these thermodynamic, physical-thermodynamic and economic-thermodynamic respectively. The measurement of the input can have an effect on the value of efficiency depending on where the boundary of the system is defined. The energy may be considered from different points in the supply chain; final (site) energy, delivered energy, primary energy, embodied energy (Pérez-Lombard, Ortiz & Velázquez 2012; dos Santos et al. 2013). These terms will be defined in section 2.2.1.

Despite decades of progress in making the energy supply chain more efficient, these improvements in technical efficiency are "diluted to insignificance by wasteful services" (Nakićenović 1993). Harris et al. (2007) argue that "energy efficiency should be seen as a means rather than an end in itself"; that it may not be sufficient to focus primarily on energy efficiency and that "conservation" has a better potential to slow (and ultimately reverse) the growth in energy consumption and CO<sub>2</sub> emissions. As we try to develop

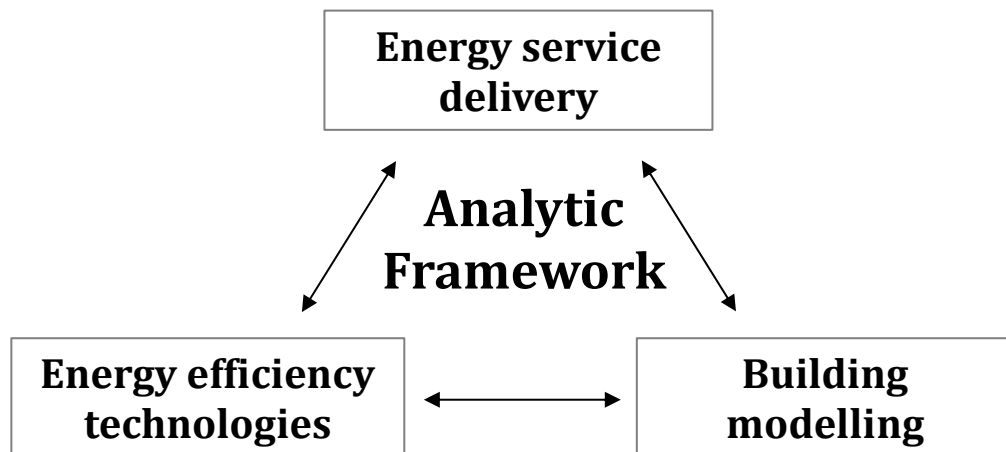
strategies for maintaining the lives we are accustomed to in a more low carbon, sustainable way, an alternative approach may allow a different way of considering the energy that we use. The supply side has historically been easily quantifiable; tonnes of oil equivalent and kilowatt hours (kWh) are convenient measures for energy use, however, this traditional focus for energy planning on the supply side has resulted in a limited view of the potential for energy reductions (Pérez-Lombard, Ortiz & Velázquez 2012; Jansen & Seebregts 2010).

Our demand for energy is not for kWh of electricity or gas but for the end-use energy services which they deliver; comfortable spaces, illumination, sustenance, hygiene, mobility, entertainment (Lovins 1976; Wirl 1995; Steinberger et al. 2009; Haas et al. 2008). Consideration of energy use through the energy service concept can be a way of reducing this final gap in efficiency, addressing both the technical and social implications of societal energy consumption. Natural scientists have been recognised as often hesitant to enter the “softer and somewhat less objective demand side” of the energy system (Nørgård 2000), but a focus on, and modelling of, the demand side is important for improving the prospective for satisfying our service requirements with fewer negative consequences as a side-effect.

Energy which goes into delivering services does so at every step in the energy chain. The biggest environmental impacts of fossil fuels come at the point of mining the primary fuel and at the transition point from primary energy to secondary energy where large amounts of CO<sub>2</sub> are released in the burning of these fuels. The product of the supply energy chain is the final energy which is delivered to the point of use, and for housing this is typically in the form of electricity and gas. The amount of this direct energy required to deliver the demanded services can be predicted using building models; for the service of thermally comfortable rooms, this involves the calculation of thermal balances within the house based on details of building structure and use. As well as this direct energy for operation, energy is also consumed in production of the building fabric or technologies in use and this indirect energy, or embodied energy, is a calculation of the energy used in the manufacture. As buildings require less energy to run, the indirect embodied energy becomes more relevant. Computational building modelling is now widely used for design of new and existing buildings and prediction of building energy consumption. In recent years, the recognition of a performance gap between building design and performance when built has led to work being undertaken to better understanding how energy is used within buildings.

### 1.3. Focus of thesis

The focus of this thesis is to investigate how the energy service concept can demonstrate a practical contribution to planning for the retrofit of hard-to-treat houses. This planning will mainly focus around the use of building modelling for predicting the most effective choices for energy efficient retrofit. The comparison of energy efficient technologies and measures will be based on the efficacy with which they deliver an energy service within the home. This focus therefore identifies three disparate areas which themselves are well developed and have received considerable attention within the literature; the energy service concept, energy efficiency technologies and building modelling. The aim of this thesis is to investigate how links can be made between these themes to present a novel framework within which the retrofit challenge can be addressed, resulting in reduced carbon emissions from the domestic sector; this analytic framework for the thesis is illustrated in Figure 1-1.



*Figure 1-1 Illustration of analytic framework*

The research questions for this thesis are based on the linkages of the analytic framework:

- **What contribution can energy efficiency technologies make in delivering low carbon energy service?**
- **How can the delivery of energy service be included in building energy modelling?**
- **To what extent can building modelling be used as a tool to recommend improvements to existing housing stock?**

The first question explores the link between the delivery of energy service and the use of energy efficiency technologies and measures which can enable a reduction in overall energy input and resulting CO<sub>2</sub> emissions. This link can work in both directions showing a mutual

benefit of such a consideration. Whilst energy efficiency technologies and measures have potential to improve the delivery of low carbon energy service in different ways, the energy service concept could have potential to deliver energy efficiency technologies and measures to houses as the policy focus is strengthened in terms of how important such technologies can be. The second question explores how building modelling can be used as a tool to predict how an energy service is or could be delivered within a home and how this service could be delivered with a lower overall energy input or resulting CO<sub>2</sub> emissions. The third question explores how different types of energy efficiency technologies and measures can be represented and realistically compared within a building model. This will involve validation of modelled savings against savings as measured in other literature and in real world studies in order to compare how first principle models represent real world operation.

As will be described in Chapter 3, the research methods undertaken to answer these questions are based on data collection from academic and industrial literature and analysis thereof, development of suitable building models to run simulations and subsequent analysis of results.

## **1.4. Thesis structure**

The thesis begins in Chapter 2 with a review of relevant literature in order to gain an understanding of the research context within which this work sits. As well as presenting the majority of the literature review for this thesis (some is interspersed in later chapters), some analysis is also undertaken at this point where it is deemed relevant. The literature review covers main topics of energy service theory, household occupants, building retrofit and building modelling.

Chapter 3 is an overview of the research framework, combining some further analysis of literature which is most relevant to framing the research areas of this study, and presenting the analytic framework for this thesis. The general methodology is introduced, but detailed methods for each approach are presented within the following three chapters.

Chapter 4 is the first of the analysis and results chapters, focussing on a suitable definition of energy service efficiency and service unit. A quasi-steady-state building model is used to compare technologies and measures which can lead to energy demand savings through different approaches to heat management. The results of this chapter contribute to the



design of the methodology for the following chapter and provide initial insight into the relative energy service efficiencies of different technology approaches.

Chapter 5 develops upon the work in the previous chapter and uses a more sophisticated dynamic energy balance model to compare the energy savings due to energy efficiency technologies and measures. The definition of energy service unit in the previous chapter leads to the choice of three different occupancy patterns as varying descriptions of service demand. Validation and sensitivity analysis of the building model is presented allowing for the reliability of results to be considered.

In Chapter 6, the focus moves to the modelling of energy service delivery, and the model is developed to enable the delivery of heating thermal comfort to be compared for different energy efficiency technologies and measures. The model used in the previous chapter is enhanced in order to better represent the internal temperature profile of a house. Four metrics are compared for giving a measure of heating thermal comfort service delivery, and conclusions are made on the relative performance of each of the energy efficiency measures.

Chapter 7 is a discussion of the new insights gained from the work of the thesis, focussing on energy efficiency technologies, energy service theory and building modelling in turn. Limitations of the work within the present study are identified alongside suggested topics for future work.

Chapter 8 is a conclusion which returns to the research questions and answers each question in turn. Three areas of future work are discussed which would enable the findings of this study to be further developed.



# Chapter 2 Literature Review

## 2.1. Introduction

This chapter provides the context for the thesis, identifying the background and relevant previous work which is shaping the research. Due to the reliance of the present study on data collection from literature, in some parts there is additional analysis included within this chapter and in other cases, further literature review is included in subsequent chapters where most relevant.

This literature review begins with energy service theory (2.2), exploring previous applications of the concept within the literature. The aim of this section is to review existing work within the energy service concept and to identify (a) how the approach can be applied to energy efficiency retrofit of homes, and (b) how the consequential work in this project can feed back into other aspects of the energy service concept. Leading on from the energy service concept, the role of household occupants in the use of energy has been identified as a valuable focus to take and forms the second section of this literature review (0). An aim of this section is to gather data on household energy behaviour in order to inform the building modelling in subsequent chapters and to identify what further empirical work might be required. The next focus of the literature is on building retrofit in section 2.4. This section presents an analysis of energy efficiency technologies as discussed, tested or recommended in a broad range of literature. This review of technologies will inform which energy efficiency technologies and measures could be used in a comparison in subsequent chapters. What follows is a summary of relevant UK domestic energy policies in recent years and a review of barriers and challenges to the adoption of different types of energy efficiency technologies in order to further inform the analysis within this thesis. The final section of this literature review is on building modelling (2.5), including an investigation of types of model which could be used in subsequent chapters. Following this is a review of previous examples of the inclusion of energy service concept within building modelling work

## 2.2. Energy services theory

Since the 1970s, academics have been interested in the research field of energy services, with the recognition that energy demand is not a desire for fuels or electricity, it is driven by a demand for the services which energy can provide – comfortable rooms, illuminated spaces, cold beverages, warm meals, food storage, hygiene, mobility, entertainment and security (Lovins 1976; Wirl 1995; Steinberger et al. 2009; Haas et al. 2008) (see Box 2-1). The term energy services is defined<sup>2</sup> in literature as 'the benefits that energy carriers produce for human wellbeing' (Modi et al. 2005), 'systems of need' or 'social demand' (Shove 2003a), or 'the ends for which the energy system provides the means' (Groscurth et al. 1995).

A range of applications for the energy service concept can be found in literature. Energy services have been used as a basis for understanding trends from the past so as to predict future trends in energy consumption (Fouquet & Pearson 2006; Reister & Devine 1981) or for identifying end uses which should be prioritised for energy efficiency work (Cullen & Allwood 2010a; Cullen et al. 2011; Cullen & Allwood 2010b; Ma et al. 2012; Höjer et al. 2011). Energy services have been used to highlight the role of users in energy efficiency analysis (Kahane 1991; Jonsson et al. 2011) and for the inclusion of people within demand side energy use in energy modelling (Pedrasa et al. 2009; Pedrasa et al. 2011; Rysanek & Choudhary 2012; Rysanek & Choudhary 2013). The focus on energy services can help to emphasise the role of culture and social values in driving energy consumption whilst offering a rich terrain to explore the complications of how humans use energy (Sovacool 2011). Finally, the energy service context has been employed to justify a re-orientation in the direction of energy policy interventions (Nørgård 2000; Haas et al. 2008; Steinberger et al. 2009; Sovacool 2011; Cravioto et al. 2014).

Through analysis of literature focussed upon or making reference to energy service theory (for the present study), three themes have been identified: consideration of energy use within a broad chain, widened approaches to service delivery, and level of service demand including the concept of sufficiency. Each theme will be explored in more detail below. Subsequently, the topic of measurement of energy service is reviewed, and finally, particular focus is directed at the service of thermal comfort.

---

<sup>2</sup> In this thesis, the term 'energy service' does *not* refer to additional services relating to and alongside energy supply

**Box 2-1** *Description of domestic energy services*

**Thermal comfort:** Thermal comfort is a 'self-conscious satisfaction with the relationship between one's body and its immediate physical environment' (Crowley 2001). No longer considered merely an achievement, thermal comfort is more typically considered as a narrow specification of normal and appropriate indoor conditions. Maintaining a thermally comfortable room typically depends on factors of heating, cooling and ventilation, depending on the climate. Delivering a service of thermal comfort has become more energy intensive as technologies for heating (central heating) and cooling (air conditioning) have become widely available and the expectations on level of service have converged internationally and throughout the year

**Sustenance: Food preparation** Cooking food changes its nutritional properties, texture and taste; this may be a requirement or a matter of preference depending on the food type. In developed countries, cooking is generally done in the house using a hob, oven, grill, microwave or toaster, whereas the majority of the cooking in developing countries uses a biomass stove. Other aspects of food preparation include chopping and mixing; traditionally these have been done by hand, but appliances such as food processors provide this service with greater convenience to the user but increase demand of electricity. **Food storage** Food and drink can be preserved by lowering its temperature and although a cold storage room can provide sufficient cooling for some perishables, most households in developed countries keep food in a fridge or freezer.

**Hygiene:** The service of hygiene comprises personal hygiene (using a shower, bath or wash basin), cleanliness of a building occupant's possessions (most commonly washing and drying clothes and kitchen ware such as crockery and pans) and cleanliness of the building itself (floors, walls, shelves, windows etc.). Some of these services which have traditionally been completed by hand, requiring hot water and/or physical labour, have been replaced by appliances (washing machine, dishwasher, tumble dryer, vacuum cleaner), increasing the electricity consumption required to deliver the services. Expectations of cleanliness have changed over time and the perception of acceptable levels of cleanliness varies greatly for different building occupants.

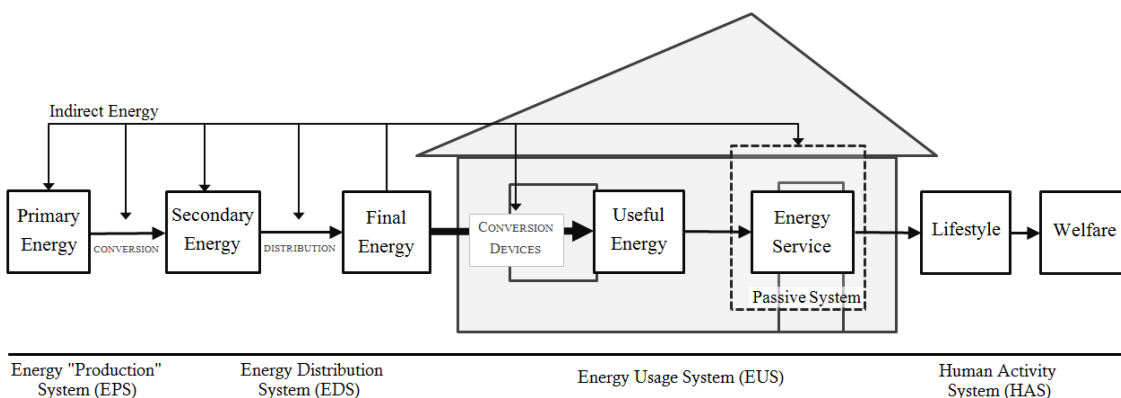
**Illumination:** The eye is a highly sophisticated organ, and enables vision through the capture and focus of light. The amount of light required by a person depends on the activities being undertaken; high light flux is expected within hospitals and offices and particularly places where intricate work is being carried out, whereas lower levels of lighting are more appropriate in a bar or restaurant to create a desired ambience. Contrasting levels of lighting can be considered uncomfortable, and the directionality of the light is also a consideration to reduce high levels of shadow or silhouetting. Illumination of a building involves the orchestration of light for the user's wellbeing, which can be achieved by electric lighting, sunlight through windows or other methods such as candles. Historically, sunlight, moon light and candles were the sole source of illumination, but since then, lighting has been provided by continuing improving lamp technologies, powered by oil, gas, kerosene and finally electricity.

**Communication and entertainment:** Over the past centuries, technological advances have developed the way that people communicate and gather information (Cairncross 1997). Ownership of computers and mobile phones has revolutionised people's ability to talk to and share information with people without direct contact, and more recently presents increasing potential for communication to replace some demand of the service of mobility. Digital technology is powered by electricity and therefore communication by computer or electrical phone increases a household's demand of electricity. Entertainment as a service provides enjoyable experiences in people's spare time. The service can be delivered in many varied ways and is highly subjective. Entertainment can be achieved through non energy intensive means, or alongside some other service (an occupant may enjoy cooking, taking a bath or talking to a person on the phone). Many of the electrical appliances used in the house (including the mobile phone and computer) are for the purpose of entertainment and ownership of appliances has increased significantly in the past decades (ONS 2011).

### 2.2.1 The energy services chain: from well to welfare

The delivery of energy service does not depend solely on the conversion of a fuel into a useful form of energy, but on a chain of stages starting at primary energy with an 'ultimate end' of welfare or 'want satisfaction' (Daly 1974; Nørgård 2000). Consideration of only one stage of this chain can distort the results of energy efficiency calculations and risks missing a great deal of potential for preserving natural resources and minimising environmental impacts (dos Santos et al. 2013; Nørgård 2000). The energy system chain has been represented in different ways in the literature, and these aspects have been drawn together by the author within the present study to produce Figure 2-1. The terms used are defined in Table 2-1. Stages in the energy chain represent energy carriers, which are forms of energy that can be used to produce mechanical work or heat or to operate chemical or physical processes (ISO 1997), transformation of energy carriers, and aspects of energy service demand. Energy losses occur at every stage of the energy chain as energy is upgraded to a more usable form (Cullen & Allwood 2010a).

The arrows included in Figure 2-1 progressing from left to right show the transformation of raw primary energy to the satisfaction of welfare, but the diagram could well have been drawn right to left in order to demonstrate the stages of energy demand. Lifestyle and definition of welfare dictate the levels of energy service demanded and hence the quantity of final energy required and the amount of primary energy called for. However, this reversed energy system can lead to a limitless supply of energy being the expectation, which is detrimental to the sustainability of the Earth (Nørgård 2000). Representation of the energy system as a linear chain severely over-simplifies the complex relationships between the different stages, and in reality the interconnections are far more intricate (Jonsson et al. 2011)



**Figure 2-1** Energy system chain (created by author, adapted from various sources (Cullen & Allwood 2010a; Nørgård 2000; Jonsson et al. 2011; dos Santos et al. 2013; Jochem 2000; Nakićenović 1993)). The image of the house shows the split between on and off site stages, in this case suggesting the example of domestic energy services.

Table 2-1 Stages in the Energy Chain

Type of Energy	Description	Examples
<b>Primary energy</b>	'The energy resource input into the whole system' (Hammond & Stapleton 2001), or the energy 'recovered or gathered directly from natural sources' (Nakićenović 1993).	Fossil fuels, other non-renewable fuels (uranium), renewables
<b>Secondary energy</b>	Primary energy is converted into a more useable form which is commonly referred to as secondary energy.	Electricity, petrol or diesel, refined gas
<b>Final energy</b>	The form of energy which is delivered to the end user or point of consumption (Steinberger et al. 2009; Nakićenović 1993). 'Secondary energy becomes final energy through distribution to point of use' (Nakićenović, Gilli, et al. 1996).	Electricity, natural gas, fuel oil, district heat, charcoal, petrol or diesel
<b>Useful Energy</b>	The radiating heat, hot water, light, or motion which produces the energy service within the passive system (Cullen et al. 2011). Final energy is converted into useful energy at point of use by appliances, or conversion devices.	Work, heat, light
<b>Indirect Energy</b>	Energy which has been required to enable the energy generation, conversion, delivery or use, both in building and maintaining the energy infrastructure and in operating it. Inclusion of this ensures the whole lifecycle of the energy system is included in the consideration.	Operation of oil refinery, embodied energy in solar cell or LED light bulb, energy required for transportation of biomass
<b>Conversion Device</b>	A technology which upgrades an energy carrier into a more useful energy carrier (Jonsson et al. 2011).	Electric heater, light bulb
<b>Energy Service</b>	"The last <i>quantifiable</i> link in the energy chain from primary energy towards welfare" (Nørgård 2000).	Thermal comfort, illumination, sustenance, hygiene
<b>Passive System</b>	"A system to which useful energy...is delivered...[and]...'lost'...as low grade heat, in exchange for final energy services" (Cullen & Allwood 2010a).	A room, a refrigerator casing
<b>Welfare</b>	"Well-being, quality of life...the ultimate end of satisfying people's real needs and wants" (Nørgård 2000).	Human needs and desires being satisfied
<b>Energy "Production" System (EPS)</b>	System through which primary energy is harnessed from nature and transformed into a secondary energy carrier.	Coal mine, electricity power station, oil drill, oil refinery, wind turbine
<b>Energy Distribution System (EDS)</b>	System through which Secondary Energy carriers are delivered to point of use, at which point energy carriers are Final Energy.	Electricity distribution (pylons, substations etc.), gas distribution network
<b>Energy Usage System (EUS)</b>	System through which final energy is used to produce energy services for end-users	Vehicles (producing transportation), lamps (producing lighting), heating equipment (producing heating)
<b>Human Activities System (HAS)</b>	The "technocratic denomination of all that which makes up our everyday lives" (Jonsson et al. 2011)	Housing, food, mobility

### 2.2.1.1 Primary energy to final energy

The first stage of the energy chain is the transformation of primary energy carriers into secondary energy carriers and distribution to the point of use as final energy (Nakićenović, Grubler, et al. 1996). Jonsson et al (2011) call these stages in the chain the 'Energy "Production" System (EPS)' and 'Energy "Distribution" System (EDS)'. Primary energy is the term commonly used for the energy input to the energy system (Jochem 2000; Pérez-Lombard et al. 2011; Nakićenović 1993; Nørgård 2000; Hammond & Stapleton 2001; Jonsson et al. 2011; dos Santos et al. 2013; Steinberger et al. 2009; Lightfoot 2007;

Gustavsson & Joelsson 2010), but the exact meaning attributed is not always clear. Definitions include 'the energy resource input into the whole system' (Hammond & Stapleton 2001), energy 'recovered or gathered directly from natural sources' (Nakićenović 1993) or the source of all energy 'needed to provide final energy services' (Gustavsson & Joelsson 2010) or 'useful work' (Lightfoot 2007). Conventional examples are fossil fuels (coal, petroleum, or natural gas), other non-renewable fuels (uranium) and renewables (wind, sunlight, geothermal, hydropower or biomass). Demirel (2012) included waste as a type of primary energy carrier despite defining primary energy as that 'extracted or captured directly from the environment'.

Primary energy carriers are converted into secondary energy carriers, which are intermediate forms of energy more easily transported and used (Nakićenović 1993; Nørgård 2000; Sathaye 2010). This conversion includes the processing of oil in a refinery to separate out fractions for different applications according to the length of the hydrocarbon chains, or the generation of electricity from coal or natural gas in a thermal power plant. Final energy is the form of energy which is delivered to the final end user or point of consumption (Steinberger et al. 2009; Nakićenović 1993) such as electricity, natural gas, fuel oil, district heat, charcoal, petrol or diesel (Jochem 2000; Nørgård 2000; dos Santos et al. 2013; Steinberger et al. 2009; Nakićenović 1993). In the context of building energy use, final energy may either be centrally provided, such as grid electricity, mains gas and district heat, or it may be self-generated by an on-site technology such as a micro wind turbine or solar panel which converts primary natural energy (wind or sun) into final energy (electricity or hot water). In some literature, the calculation of primary energy is approached in a reversed manner as the sum of downstream delivered energy plus upstream losses along the chain (Hammond & Stapleton 2001; Gustavsson & Joelsson 2010).

### *2.2.1.2 Final energy to energy service*

The next step in the energy chain is referred to by Groscurth et al (1995) as the 'Energy-Services Supply System' or by Jonsson et al (2011) as the 'Energy Usage System (EUS)' and comprises the delivery of energy services from final energy. It is this stage of the energy chain which is the sole focus of many energy efficiency policies for buildings and appliances.

Cullen and Allwood (2010a) introduced a novel approach to considering energy service delivery, comprising an active end use conversion device and a passive system. The end-use conversion device is the technical component which can convert a final energy energy-carrier into a useful form of energy (e.g. chemical energy (natural gas) converted into heat



energy within a boiler, or electrical energy converted into rotational motion and ‘cooling’ within a refrigerator). The passive system is the final technical component in the energy chain within which the useful form of energy delivers an energy service (such as the room in which heat energy delivers thermal comfort, or the insulated cold box in which ‘cooling’ delivers food preservation). Any remaining energy is dissipated to the surroundings as low grade heat. The distinction between conversion device and passive system has been used to consider the practical limits for energy reduction within the global energy system (Cullen et al. 2011) and to map the flow of energy to deliver thermal comfort within a building heating, ventilation and air-conditioning (HVAC) system (Pérez-Lombard et al. 2011).

### *2.2.1.3 Energy service to welfare*

This final part of the energy chain is less commonly a focus of energy system analysis and fits more within the realms of social science or development studies. It is the stage in which service demand is defined. Nørgård (2000) extended the full energy chain beyond energy services through 'lifestyle' ('the system in which people organise society and daily behaviour in an attempt to satisfy their needs...reflect[ing] their needs and social values but constrained by the frames provided by the natural environment and society') and 'welfare' ('well-being, quality of life...the ultimate end of satisfying people's real needs and wants'). Jonsson et al. (2011) named this the 'Human Activity System (HAS)', 'an admittedly technocratic denomination of all that which makes up our everyday lives'. By including the HAS step in the chain, they aim to contribute to previous discussions on how to highlight and explore the user side in the analysis of energy systems in an efficiency context.

The level of service required to satisfy welfare varies greatly between different cultures and has changed significantly over time; expectation of service demand has escalated alongside the development of technologies and has resulted in ever increasing levels of energy consumption, but it is possible that future concepts will be less resource intensive than those of today (Shove 2003b). Shove (2003b) advocates that what people take to be normal is 'immensely malleable', but that individual practices are not 'free-floating expressions of personal preference', but are governed by what is perceived by society to be normal, related to respectability and appropriateness. Related to this is the concept by Haas et al. (2008) that short term and long term components of service demand exist. Short term aspects are related to behaviour and choice; selection of temperature setting, km driven and stand-by operation of a TV or computer. Long term aspects are related to societal practices and infrastructure on a large and small scale; size of households, working hours, area of an apartment, size of car and number of light fixtures.

Nørgård (2000) suggests that welfare can be divided into 'satisfying basic human needs which are universally shared by all humans' and 'desires arising from cultural values, which

are very diverse'. He goes on to introduce 'Lifestyle efficiency' as a broad concept for how well a lifestyle system turns energy services into welfare, but states that such a ratio cannot be expressed by numbers, only by 'soft parameters'. This framework allows different cultural variations to be compared and ethical question arises of how much of the focus of reducing energy demand across society can or should be directed at shifting towards less energy intensive lifestyle choices.

#### ***2.2.1.4 Indirect energy***

An additional aspect of the energy system chain is the indirect energy which feeds into every stage, concealed within the embodied energy of the technologies, materials, structures and other objects on which the energy system relies such as consumer goods, buildings, machines, steel making, electricity pylons and tables. (Cullen & Allwood 2010a; Jonsson et al. 2011; Lovins 1976; Jochem 2000). These aspects have been described as 'indirect energy services' (Haas et al. 2008; Jonsson et al. 2011). Methods for including embodied energy and all lifecycle aspects of energy use and waste in analysis of energy impact have been developed within the field of Life-Cycle Assessment (LCA) and can be extended to analysis of indirect energy services.

It is not only energy which goes to the delivery of services; water, materials, infrastructure and data are examples of other flows which are required; Jonsson et al. (2011) explicitly used the term services as opposed to energy services in recognition of the broad inputs required. Knoeri et al. (2015) refer to 'infrastructure end-use services' and Roelich et al.(2015) use the term 'multi-utility service'.

### **2.2.2 Approaches to delivery of energy services**

The second main theme of energy service literature is that a consideration of energy service delivery rather than only energy supply allows a broader approach to consideration of the energy system. This is in terms of the way that energy use is framed across the whole economy or at the point of use, and how consideration of energy service is applied to the business model of an energy service company (ESCo).

#### ***2.2.2.1 Framing of energy usage***

Jonsson (2011) made recommendations that energy usage should be analysed not through an understanding of energy usage patterns but through '*energy usage logics*'; '*why* a service is called upon, *what* type of service is needed, and *how* the service can be delivered'. They address the *why* by highlighting the difference between practical, symbolic and aesthetic services. They demonstrate the *what* through work by Höjer et al. (2011) who produced a breakdown of the total energy use in Sweden in 2000 into the 'household functions' of

personal, residence, food, care, common and support. In this case, food includes all energy to grow, process, transport, sell, store and cook food, rather than the traditional system where energy end uses are divided into 'geographical areas of actual energy use', separating farms, shops and homes as different entities. The *how* is addressed through a framework for considering alternative ways of delivering a service by identifying the volume, content, quality and motivation of a service (as discussed in section 2.2.4). It is argued that by shifting expectations of how services are produced, welfare and well-being can be maintained and with a lower energy requirement (Jonsson et al. 2011; Nørgård 2000). An energy service approach re-orientates the direction of energy policy interventions (Nørgård 2000; Haas et al. 2008; Steinberger et al. 2009; Sovacool 2011; Cravioto et al. 2014), away from a policy focus on obtaining barrels of oil, but on a more diffuse range of options such as promoting cycling, improving appliance energy efficiency and altering conceptions of luxury (Sovacool 2011). A change in behaviour doesn't have to be a sacrifice, and as shown by Shove (2003b), the current expectations of comfort, cleanliness and convenience have grown out of the 'coevolution between, e.g. scientific paradigm, changing socio-technical systems marketing and changing cultural and symbolic meanings of everyday practises'.

### 2.2.2.2 *Energy service companies*

In recognition of the supply-side focus of the energy economy with a structure based fundamentally on profits through energy throughput, Steinberger et al (2009) advocated for a performance-based energy economy (PBEE). A PBEE would recognise energy service provision as the end goal of the energy system and put energy services at the centre of energy policy design. An example of PBEE practice is the energy service company (ESCO) business model. The ESCo business model differs from a typical energy supply model as it gives an aligned incentive between reducing energy consumption (and therefore the impacts of climate change) and generating business profit. At the heart of the concept of ESCos is the idea that a defined level of energy service can be delivered to an end-user in different ways and at different cost. As energy becomes more expensive, money can be saved by investment of capital expenditure in installing energy efficiency measures which lowers energy demand and thus reduces the cost of final energy (Shippee et al. 1996). The ESCo business model has been adapted to suit different international markets (Bertoldi et al. 2006; Marino et al. 2011), but the fundamental idea is that installation of energy efficiency technologies and other demand side management approaches can result in the same service being delivered for a lower overall energy usage, therefore offering financial and environmental benefits.

Typically, ESCos have focussed on industry or large commercial buildings and facilities such as hospitals and universities (Vine 2005; Bertoldi et al. 2006; Sorrell 2007), but some studies have considered the application to domestic buildings, referred to as a domestic-ESCo (DESCo) (Morris-Marsham 2012) or sustainable energy utility (Houck & Rickerson 2009). Morris-Marsham (2012) identified the benefits and drawbacks of the DESCo business model:

- Economic benefits directly apply to the customer such as lower capital costs, increased access to capital or no upfront cost, reduced search costs and reduced performance risk for customer.
- Socio-cultural benefits include reduced customer inertia and encouragement for behaviour change.
- Economic drawbacks are taken on by the DESCo including high risk of stranded assets, comfort taking by the customer (a type of rebound effect as described in Box 2-2), performance risk of energy efficiency measures and energy price risk. There is also a high transaction cost which must be covered by DESCo or customer; the transaction cost per energy savings is far higher for a domestic customer than for large energy using buildings and facilities and this remains one of the largest barriers to uptake of ESCo type business models in the domestic sector.
- Socio-cultural drawbacks are a disinclination towards long term contracts and unfamiliar measures, and the new business model fails to tackle non-financial barriers such as hassle and disruption.
- Other institutional barriers exist such as the regulatory landscape of the current energy supply market.

The UK's Green Deal Programme was a type of DESCo model and its apparent failure was a product of high risk and transaction costs leading to a loan with an unattractively high interest rate.

### **2.2.3 Sufficiency**

The concept of energy sufficiency is the third application of energy service theory, and literature concerning energy sufficiency can be divided into two themes; the recognition that improved energy efficiency has failed to deliver the energy savings which were hoped for due to a continual increase in the level of energy services demanded and delivered, and the perceived inequity of level of service between different people. These two areas are further explained below.

### 2.2.3.1 *Energy efficiency failing to deliver energy savings*

Nakićenović (1993) argued that energy reduction requires not only 'the reduction in specific energy needs for performing a given task', but 'the reduction in energy needs due to changes in the nature or level of the required energy services', defining these aims as energy efficiency and energy conservation respectively. Similarly, Harris et al (2008) debate that energy efficiency is a means rather than an end, and that policy requires 'a return to an earlier emphasis on "conservation"'. The phenomenon of energy service increase has been documented for lighting (Fouquet & Pearson 2006), for expectations of 'comfort, cleanliness and convenience' (Shove 2003a), for house size (despite an equal decrease in household size) (Harris et al. 2008). Darby (2007) designates that energy efficiency and sufficiency belong together in developing future policy; efficiency nests within sufficiency which itself must fit within the ecological carrying capacity of the Earth. Herring (2006) wrote that the 'gospel' of energy efficiency was 'fatally flawed' due to the preference to take efficiency savings through higher levels of energy services. He contrasted 'energy conservation' and 'energy efficiency', defining energy efficiency as 'simply the ratio of energy services out to energy input' whereas energy conservation was achieved 'through reduced quality of energy services'. Similarly, Alcott (2008) defined sufficiency as enduring a lower level of utility or welfare; *not* as 'boiling only the amount of water needed for the cup of coffee', but 'doing without the cup of coffee', or *not* as 'carpooling', but 'not taking the car'. Herring concluded that curbs on consumption through regulation or taxation were needed and a goal of less CO<sub>2</sub> emissions rather than lower energy use. These problems are perhaps reflective of the definition of energy services not fully describing the services which people require. If energy services can be defined closer to the satisfaction of welfare (to be well fed) than the use of useful energy (to cook a kilogram of food), with a closer consideration of sufficiency, these aspects could be reduced.

### 2.2.3.2 *Inequity between people*

Daly (1974) defined services as 'want satisfaction', but there is a wide disparity between levels of service which people are delivered nationally and internationally. At low levels of income and development, people rely on a small number of energy services to survive (cooking, heating, lighting). As people or societies develop, they demand a much broader range of services to thrive, and even beyond that consume additional energy for the purpose of demonstrating their affluence (Sovacool 2011). An increase in energy service gains has been shown to yield decreasing returns, with a saturation level reached as income increases (Cravioto et al. 2014) and the link between energy and development weakens above a fairly low threshold (Steinberger & Roberts 2010).

Darby (2007) discussed the broad definitions of sufficiency in both qualitative and quantitative terms. Qualitatively, sufficiency implies wealth and plenty, that ‘need is satisfied’, ‘a purpose is achieved’ and ‘some sort of optimal state is reached’. Quantitatively, she describes an implied ‘*threshold* of acceptability’, and a level existing between a ‘floor’ (a minimum level which is enough for a necessary purpose) and a ‘ceiling’ (a maximum level which is too much for safety or welfare). The ‘normative nature of sufficiency’ is highlighted when applying ‘boundaries to a social order’; to dictate that ‘so much is enough’ and ‘so much is too much’ requires a normative judgement (a value judgement of what ‘should’ be which cannot be proven or disproven by fact). These judgements may be made more acceptable with the development of better qualitative indicators of how sufficiency can improve or maintain quality of life, and examples are given around use of time (e.g. valuing the importance of rest), livelihoods (e.g. rewarding full employment rather than labour productivity) and credibility (e.g. more transparency of the whole energy chain and communicating results of sufficiency policies). Darby stresses that sufficiency is not a fixed state, but requires change and movement which may be cyclical or linear.

### 2.2.3.3 *Applications of the sufficiency concept*

Brischke et al. (2015) focus on energy sufficiency in the context of household appliances, defining sufficiency as a *strategy* to reduce energy. They identify a chain from basic need to technical service supplied, comprising five steps. At the beginning, energy consumption stems from culturally independent ‘basic need’, which is translated into ‘demands, needs and desires’, and made concrete through culture and lifestyle. Demand for service is thus split into ‘utility needed’ and ‘utility aspects desired’ and these combine to define the ‘technical utility demanded’. Consequently ‘technical service supplied’ is the final step, depending on the characteristics and features of the technologies and appliance in place to deliver the utility or service. For the implementation of sufficiency, three types of intervention are identified; reduction, substitution and adjustment. Reduction is a quantitative change in utility and can be applied either to the ‘utility needed, utility aspects desired’ step or the ‘technical utility demanded’ step. Substitution is related to purchase decisions, technology use, aspects of provision, or lifestyle, and can apply to all steps in the chain as different interpretations of ‘basic need’. Adjustment is a tailored-fit solution such that the ‘technical service supplied’ matches to the ‘technical utility demanded’ which in turn satisfies the ‘utility needed, utility aspects desired’ in the most efficient way. When applying their approach to the field of washing, drying and dish washing, the energy saving potential of sufficiency was estimated to be two times higher than the potential of efficiency. Recommendations for the development of appliance energy policy around energy labelling and eco-design requirements have been identified based on the concepts of

reduction (avoidance of super-sizing and functional redundancy), substitution (products and features that change daily routines and social practices towards energy sufficiency) and adjustment (automatically opting for energy and resource saving functions and adjustment to the desired level of service).

Harris et al (2008) use the notion of sufficiency in their promotion of the concept of 'progressive efficiency' whereby higher levels of efficiency standards could be applied as a greater level of energy service is delivered. The example of homes in USA is used whereby the current trend for preference for larger houses is exacerbated by it being easier for larger homes to achieve higher energy efficiency ratings than smaller homes due to criteria in the rating systems. Since these larger homes still have higher energy consumption per person, it is suggested that larger homes should have more stringent requirements to achieve the highest ratings for energy efficiency, and policy aspects which encourage smaller houses should be extended.

Haas et al. (2008) also used the concept of energy services and sufficiency to identify necessary changes in trends and policies for achieving a transition towards more sustainable energy systems and development path. They concluded that this transition away from impending global warming and unsustainable development required four major areas of focus. They advocate that a rigorous rethinking is needed in order to identify what level of energy service provision per capita should be a target. They believe that a significant increase in energy conversion efficiency is necessary so as to provide energy services with far less energy input than today, and that this improvement in technical efficiency must be matched with proper energy price and regulatory policies. Finally, they propose that a continual increase in the share of renewable energy sources and other low-emission options is required.

### **2.2.4 Measurement of energy service delivery**

There is no consensus in the literature as to how energy services should be measured, and in fact whether they can be measured at all. Due to the complexity of valuing the output of a service, tied into consideration of varying perceptions of 'quality of life', 'lifestyle' and 'welfare', Jonsson et al. (2011) suggest that 'service should be considered quantifiable only in part'. Steinberger et al (2009) declare that energy services are not measurable in units of energy as they rely on specific technologies and local conditions (such as climate, landscape or the urban fabric). Some difficulties in measurement relate to the fact that services have various dimensions of scope, and Pérez-Lombard et al. (2012) highlighted the difficulty in quantifying the very diverse range of activities which services encompass, suggesting the differentiation between quality and quantity. They propose that energy efficiency indicators of any system or device are best sought in a case by case basis. Beyond quality

and quantity, Jonsson et al. (2011) presented a rigorous qualitative framework for comparing 'complementary views' of service through four underlying aspects: *Volume*, (the underlying 'quantifiable amount of energy service delivered' such as passenger-km for transport and area of thermally conditioned rooms), *Content* (the 'experienced utility of service' such as thermal comfort or commuting to work), *Quality* (the 'experienced reliability, accessibility, safety and security, convenience and ease' such as acceptable journey time, ease of control panel for heating system or reliability of electricity delivered from the grid) and *Motivation* (the reasons for 'why a service is called upon' which may be practical (those which sustain comfortable everyday life), symbolic (those with symbolic value which support a certain lifestyle) or aesthetic (those which convey feelings of wellbeing to an individual)).

Attempts to quantify energy services have, however, been made. These have in part depended on the definition of service used. Resiter and Devine (1981) and Saracool (2011) described measures of services as heat provided to rooms, water, cook-wear etc. and electricity consumed by lighting, and electronic or appliance services etc.; this approach allows services to be measured in Watts of useful energy which deliver the service. In a similar way, energy efficiency indicators have been developed to allow the comparison of energy efficiency progress between different countries and time periods, for which breaking down energy use to end-use, such as for space heating, has been considered useful (Bosseboeuf et al. 1997; Haas 1997). Haas (1997) stated the importance of linking these end use indicators to the specific services which the energy is delivering, explaining that cross country comparisons were complicated due to the demand for services being shaped by a variety of factors of lifestyle, culture and human behaviour. He described technical efficiency as how much energy is needed to provide a certain amount of service, and this was related to the level of service demanded, depending on both long-term demand ('structure') and short-term demand ('behaviour').

Cullen and Allwood (2010a) in contrast measured the energy services as cubic metre-Kelvin (air) for thermal comfort, lumen-seconds for illumination, cubic metre-Kelvin (hot water) and Newton-metre (work) for hygiene, Joule (food) for sustenance and bytes for communication. They couple these with the energy which goes to delivering the services (annually) measured in Joules. Nørgård (2000) suggested there is a 'some haze around energy services' since they are not usually measured in the same units and there is not one unambiguous definition of them. He wrote of four types of energy services according to the way they can be recorded; those measured in energy units, those measurable in other physical units, those measurable in monetary units and those that are not quantifiable. He suggests that the energy service concept refers only to the output of end-use technologies which are measurable in physical units, although energy units are only possible in a few



cases. When there can be a market value ascribed to physical energy services, monetary units can be used for measurement, and he takes this further to say that any service can be given a monetary value based on the cost of all the elements required in delivering the service, however, when physical units are possible, these are more illustrative and more relevant. The non-quantifiable services are those which contribute to more general welfare for which it is the pleasure or enjoyment of the service which is the resulting output and therefore measurement is non-trivial in typical SI units.

A concept akin to service efficiency (or the inverse, service energy intensity) has featured in a number of publications representing a measure of energy input to service output, or improved efficiency signified by lower consumption of useful energy without a loss of service quality, or getting more service from the same input (Patterson 1996; Daly 1974; Cullen & Allwood 2010a; Nørgård 2000; Jonsson et al. 2011; Nakićenović 1993). Daly (1974) used the term 'service efficiency' in his equation to describe 'ultimate efficiency' as 'getting more service per unit of time from the same stock' (where stock is the wealth and materials within a steady state economy). Patterson's (1996) 'physical-thermodynamic indicators', and Haas et al.'s (2008) term 'technical efficiency' both gave a measurement of a specific energy service per energy input. In other cases, the inverse is used; Pérez-Lombard et al.'s (2012) definition of energy intensity, and Cullen and Allwood's (2011) term 'utilisation ratio' calculates the ratio of energy input to service output.

The approach to measuring energy services dictates whether there are risks of rebound in service demand. When services are defined as 'travel', 'lighting' or 'heated floor area', a cost decrease has shown to result in an increase in distances travelled, amount of lighting used, size of buildings heated, or heating temperatures (Sorrell 2009; Fouquet & Pearson 2006). Haas *et al.* (2008) used historical data to demonstrate the rebound effect of increasing demand for energy services as technical efficiency improved. They compare the price for the services of transport and lighting to the demand growth in the period 1700-2000, and conclude that since there was not significant decrease in the cost of energy in this period, the reduction in cost of service due to technical efficiency improvements had led in part to an increasing demand. They recommend that efficiency improvements should be accompanied by proper energy price and regulatory policy, however, alternative description of services could reduce the potential for unwanted rebound effects, such as the definitions of service described by Jonsson *et al.* (2011) above.

### 2.2.5 Thermal comfort

The final part of this review of energy service literature focusses on the service of thermal comfort. Different approaches have been developed, particularly with a view to quantifying thermal comfort delivery.

#### 2.2.5.1 *Physiological approach to thermal comfort*

The physiological approach to thermal comfort states that the main purpose of heating or cooling within a building is to sustain an equilibrium over a person's body. The human body maintains a constant temperature around 37 °C and emits an average heat output of 100 W (70 W during sleep up to over 700 W during vigorous activity). This heat must be dissipated to the surrounding air in order to retain thermal comfort. Variables which affect thermal comfort include environmental (air temperature, air movement, humidity, radiation), personal (metabolic rate, clothing, state of health, acclimatisation) and other contributing factors (food and drink, body shape, subcutaneous fat, age and gender). Air temperature determines convective heat dissipation and air movement can accelerate convection as well as increasing evaporation (producing a psychological cooling effect). The condition of equilibrium is that the total change in stored heat within a body is zero (Szokolay 2007).

#### 2.2.5.2 *Fanger's model of thermal comfort*

Fanger (1967) developed methods to quantify the thermal comfort (van Hoof 2008), which comprised measurements of Predicted Mean Vote (PMV) and Percentage Person Dissatisfied (PPD). PMV is an index based on the mean value of a vote by a large group of persons on a 7-point thermal sensation scale (+3: Hot, 0: Neutral, -3: Cold). A calculated value of PMV includes personal and environmental factors. Personal factors include metabolic rate, effective power of the occupant, clothing insulation, clothing surface factor and clothing surface temperature. Environmental factors include air temperature, mean radiant temperature, relative air velocity, water vapour partial pressure and convective heat transfer coefficient.

PMV is typically calculated using an equation for PMV including the environmental and personal factors listed above. PMV can also be determined from tables which list values of PMV for different combinations of activity, clothing, operative temperature and relative velocity, or by direct measurement using an integrated sensor. PPD gives a quantitative prediction of the number of people who would be too hot or too cold within a given thermal environment, representing the scattering of individual voters about the mean value. PPD is calculated directly from the value of PMV. PMV is typically used to check that a

thermal environment complies with comfort standards, or to predict the combinations of activity, clothing and environmental parameters which would on average deliver a thermally neutral sensation. PPD reflects the fact that not everyone will ever be thermally comfortable at the same environmental conditions due to individual differences. PMV and PPD are therefore most applicable to spaces inhabited by large numbers of people such as offices and commercial buildings, rather than houses which typically have only a few regular occupants.

### *2.2.5.3 Adaptive models of thermal comfort*

Adaptive models for thermal comfort are based on the idea that the outside climate influences indoor comfort and that people can adapt to different temperatures during different times of the year. Brager and de Dear (1998) highlight that an important premise of the adaptive models is that a person is no longer a passive recipient of a given thermal environment, but instead is an active agent interacting with the person-environment system via multiple feedback loops. Whilst Fanger's models represent an engineering approach to thermal comfort, adaptive models lie more within the scope of psychology. In a review of thermal adaptation in the built environment, Brager and de Dear (1998) reveal that thermal adaptation can be understood in three ways: behavioural adjustment, physiological acclimatisation and psychological habituation or expectation.

Typical findings of studies into thermal comfort in buildings show that occupants in naturally ventilated buildings have more relaxed expectations of temperature and are more tolerant of temperature swings, whilst preferring temperatures which track the outdoor climate. In contrast, occupants in mechanically controlled (air-conditioned) buildings had more rigid expectation of cool and uniform thermal environment (de Dear 2004; Toftum et al. 2009; Yang et al. 2014). Naturally ventilated buildings typically afford users the option of thermal adaptation (such as opening or shutting a window), whereas mechanically ventilated buildings have little option for thermal adaptation.

### *2.2.5.4 People's perception of thermal comfort*

Huebner et al. (2013) undertook surveys with social housing tenants and university staff and found that 'warmth' was most often given as the defining element of comfort, but comfort was also associated with 'security', 'enough space' and 'peace and quiet'. Madsen (2014) found that "residential comfort is as well about temperature as it is about light, functionality and homeliness". Shove (2003b) describes comfort as a 'social construction' demonstrated by examples of temporal and geographic variability. Ellsworth-Krebs (2014) undertook qualitative research consisting of in-depth interviews with whole households in order to understand the meaning of comfort. The houses in question were located in Fife,

Scotland, which not only has a mild climate but also a typically 'leaky' housing stock. This led to common remarks around the importance of making a 'cuppa' tea, filling a hot water bottle to keep warm or using curtains to contain pockets of warmth or stop drafts. Other issues around comfort were to do with air quality, including the benefits of mechanical ventilation with heat recovery (MVHR), and comfort or satisfaction gained through having a greater connection with energy supply through micro-generation of electricity or heat.

## **2.3. Household occupants**

Without people to live in them, houses fail to deliver the services intended of them such as security, comfort and convenience. However, with the introduction of people into buildings, they are no longer a uniform or predictable environment. Following on from the overview of the energy service concept, this next section focusses specifically on the role of people on energy use in houses. By gaining insight into which behaviour<sup>3</sup> factors impact on energy use and how energy behaviours vary for different people, household occupants can be better included in the analysis of this thesis. Following an initial illustration of the motivation for including behaviour factors, approaches to understanding occupant actions are presented, both in terms of analytic theory and empirical methods. Subsequently, insight into household energy behaviours is presented based on a broad analysis of studies, and finally existing archetypes of household occupants are reviewed.

### **2.3.1 Effect of building occupants on household energy use**

Gram-Hanssen (2003 in Danish; discussed further in Gram-Hanssen 2004; Gram-Hanssen 2012), undertook a study of 1,000 quite similar Danish houses built in the 1970s and found that despite similar building size and construction, the energy usage varied greatly. A comparison of heating consumption showed that those households using the least energy consumed less than a third of those consuming the most, despite identical heating system and building envelope. For electricity consumption (in appliances and lighting), the highest consumers used five times as much as those using the least. Post occupancy

---

<sup>3</sup> It is acknowledged that the term 'behaviour' itself will cause consternation to scholars working in the field of practice theory (see below), as the theory conjectures that behaviours (focussed on the actions of an individual) do not exist and that all actions are learned, socially held practices. In this thesis, I am using the term 'behaviour' in the same manner as Wilson and Chatterton (2011) in which a 'behaviour' is an observable action.

evaluation of 26 UK EcoHomes with an 'excellent' rating by Gill et al. (2010) found a similar spread of energy consumption despite similar houses; again, a factor of 3 was measured between the lowest consuming and highest consuming houses with regards to heating consumption. In a review of similar studies, including comparison between average consumption in low-energy houses and those which are less energy efficient, it was shown that behaviour counts for a factor 2–3 whereas efficiency counts for a factor 2 when comparing energy consumption for heating and therefore behaviour is as important or even more important than the designed and rated efficiency of the house (Gram-Hanssen 2012).

A number of studies have tried to establish which aspects of buildings and behaviour have the biggest effects on energy usage and the results are presented in Table 2-2. Guerra-Santin et al. (2009) used the KWR (Kwalitatieve Woning Registratie) database from the Ministry of Housing in the Netherlands as completed in 2000. The database includes information on 15,000 houses across the Netherlands in the form of an interview based survey (gaining insight into household characteristics and the use of the dwelling, such as presence at home, heating and ventilation behaviour), data from the inspection of the building characteristics of the dwelling, (such as the percentage of insulation per surface, type of materials, or type of heating system), and data for 3 years of energy use (obtained from energy providers). McLoughlin et al. (2012) examined the influence of dwelling and occupant characteristics on domestic electricity consumption patterns by analysing data obtained from a smart metering survey of a representative cross section of approximately 4200 domestic Irish dwellings.

*Table 2-2 Reported dwelling and occupant factors which affect energy use*

	<b>Factors which decrease energy use</b>	<b>Factors which increase energy use</b>
<b>Type of house</b>	Non-detached buildings <sup>1</sup> Apartment dwellings <sup>2</sup> New-buildings <sup>1</sup>	Detached buildings <sup>1</sup> Number of bedrooms (proxy for house size) <sup>2</sup> Presence of garage, shed or basement (probably due to user heating these areas) <sup>1</sup> Privately rented houses <sup>1</sup> Heating costs included in rent <sup>1</sup>
<b>Household demographics</b>		Older household, larger household <sup>1</sup> / Head of Household age group 36–55 (attributed to prevalence of children) <sup>2</sup> Higher income <sup>1</sup> , Higher professionals (social class) <sup>2</sup>
<b>Occupancy pattern</b>	Users not often at home, or with variable presence <sup>1</sup>	Continuous presence of people at home <sup>1</sup>
<b>Insulation</b>	Insulated surfaces <sup>1</sup>	Insulated piping <sup>1</sup>
<b>Heating controls</b>		Presence of thermostat <sup>1</sup> More rooms heated to higher temperature set-point <sup>1</sup>
<b>Appliances</b>		Electricity for water heating and cooking <sup>2</sup> Presence of tumble dryers and dishwashers <sup>2</sup> Presence of bath (increase in energy use related to water heating) <sup>1</sup>

<sup>1</sup> (Guerra-Santin et al. 2009), <sup>2</sup>(McLoughlin et al. 2012)

### 2.3.2 Approaches to understanding people

Investigation of behaviours allows for a greater understanding of why they emerge and their associated impacts, typically motivated by an objective to change them (Gill et al. 2010). In order to build an understanding of household energy behaviours, different theories exist for what and why people do what they do. To give insight into household energy behaviours, two contrasting theories are explained and compared below; these are applied behavioural research and social practice theory. This is followed by a comparison of empirical methods for gaining insight into household energy behaviours.

#### 2.3.2.1 Theories of behaviour and practice

Applied behavioural research includes fields of psychology and behavioural economics, and is based on the concept that people are rational beings. Shove (2010) described this as the ‘ABC’ of attitudes, behaviours and choices: people have attitudes, attitudes lead to behaviours, and people choose their behaviours. Behavioural economics considers that behaviours are subject to drivers (saving energy, increasing comfort) and barriers (upfront costs, lack of information) such that if barriers can be identified and removed, people will

do the rational thing that saves money (Jaffe & Stavins 1994; Weber 1997; Gifford et al. 2011). In the psychology theory of planned behaviour, behaviour is the aggregated response of a person, resulting as a consequence of complex interactions between internal and external factors which might include emotional, moral, habitual, contextual, attitudinal, social, normative and control factors (Gill et al. 2010). Theory of planned behaviour is most aligned to the objective of changing behaviours, using approaches such as descriptive norms (Allcott 2011). Descriptive norms are based on a person's perceptions of the behaviours that are being performed by other people similar to themselves. An example of a behaviour change programme using descriptive norms is a study by Goldstein et al. (2008) investigating how best to encourage hotel guests to reuse their towel. The most successful message for a washroom towel rack was a descriptive norm through which hotel guests were informed that 75 % of guest who stayed in their room used their towel more than once.

In social practice theory (SPT) on the other hand, practices become the focus of enquiry for any activity rather than the individual who performs the practice. Social practices are described as bundles of 'sayings and doings that are enacted and performed and so reproduced through time and space' (Gram-Hanssen 2011). SPT highlights that individuals are not solely responsible for their behaviours, as actions are socially learned, linked to habits, lifestyle, and culture. Practices can be understood to be made up of inter-related elements; Shove and Pantzar (2005) identified three elements of materials, competence (skill or knowhow) and meaning, to which Gram-Hanssen (2011) added institutionalised knowledge and explicit rules. Social practice theory (SPT) highlights that these elements are all significant in determining what practices people will perform and how practices spread through society. Technologies are classed as material elements of practices, and are part of the necessary infrastructure of a house and the wider society to enable a practice to take place. However, technical approaches to energy analysis often neglect to consider the other important elements and therefore mis-calculations are made about the ways technologies will be used and will perform.

The differences in the disparate approaches of applied behavioural research and SPT can be illustrated using the example of showering. Showering uses energy for heating water and therefore an energy saving tactic is to reduce the length of time for which people shower. A behavioural economics approach would be to say 'if you reduce the length of your shower to 4 minutes you could save £\*\* over the year'. A psychological approach would use a descriptive norm such as: 'most people living on this street shower for 4 minutes'. A practice theory approach would consider showering to be a social norm and that the most energy would be saved if the expectation changed to people taking fewer showers in the week. By considering the meaning of showering being comfort and warmth as well as

cleaning, the shower could be seen to be replaced by a warm dressing gown to continue the feeling of comfort and warmth outside of the shower.

Another example is the consideration by Wilson et al (2015) of why people decide to renovate their homes to improve energy efficiency, in which they contrast the differences between an applied behavioural research approach and a SPT approach. The applied behavioural research approach is said to see renovation as discrete one-off events involving energy efficiency technologies only whilst SPT views renovation as being part of everyday life, including other aspects in home renovations. In applied behavioural research, houses are seen as physical structures and households are treated as discrete units of measurement, whereas in SPT houses are seen as homes, and households are seen to function as groups of multiple decision makers. An applied behavioural research approach is said to focus on identifying and removing barriers, specifically concentrating on cost-effective renovations and financial aspects, whereas a SPT perspective would advocate that energy efficiency renovations would be more successfully increased by understanding the reasons for renovating and situating policy interventions to increase retrofit around everyday life appropriately.

There is some degree of animosity between these theories, as can best be exemplified in the to-and-fro debate around Shove's paper 'Beyond the ABC' (Shove 2010). In the initial paper, Shove criticises the dominant paradigm of behavioural economics (the 'ABC' of attitude, behaviour, choice) for leading to a certain form of governance with blind spots around the perceived value-action gap and how to address habits. By restricting social science input into policy making to only that which is theoretically consistent with this dominant paradigm, she claims the contributions from SPT are treated as irrelevant rather than a different way to consider these blind spots. In their response, Whitmarsh et al. (2011) criticise what they consider Shove's simplistic portrayal of psychological models of behaviour, and refute the claim that behavioural and practice perspective are "chalk and cheese", quoting many examples of successful interdisciplinary work which brings together the sociological, psychological, and other approaches. Shove's retort is that the different approaches 'generate different methods of enquiry, different meanings of evidence and different sorts of research agendas' and suggests that difficulties in overcoming policy problems around climate change stem from problems being incorrectly framed around individuals and habits rather than routines and practices as the central units of enquiry. Wilson and Chatterton (2011) suggest a pragmatic solution to the debate from the point of view of practice theorists with experience in UK policy making; although the different models may not work together, they can each offer different insight and recommendations into the joint challenge of tackling climate change. The defensiveness of some practice theorists is explained by the observation that a 'drivers and barriers' framing reduces social



science to explaining and filling the energy efficiency gap identified by technical analysis under assumptions of psychologically motivated individual decision makers, rather than letting social science define the problem for itself (Shove 1998; Wilson et al. 2015).

### *2.3.2.2 Empirical methods for understanding people as occupants*

Regardless of the method for understanding and attempting to influence behaviours, there exists a wide variety in the ways in which people undertake energy using activities within the house that account for the wide variation in observed energy consumption. There is a range of literature which attempts to create a picture of people as occupants of their homes. An understanding of behaviours can be attained in qualitative or quantitative studies by interviews and dialogue or by observation and monitoring.

Qualitative methods are most commonly used in social science studies and can be used to investigate the why and how of human behaviour. Hitchings (2011) argues that people can talk about their practices, although attention to interview method is required when asking questions which are likely to be 'uncomfortably banal' (Hitchings and Day 2011) and mundane topics that they have never talked about before. Gram-Hanssen (2010) undertook interviews with householders as part of a broader study focussed on electricity, water and heat consumption in a suburb of Copenhagen, Denmark. Five families' approaches to regulating their indoor environment are described in detail and show evidence of a broad range of practices. These include daily and annual heating periods, temperature of rooms and variation in room temperature within the dwelling, use of heating controls and thermostatic radiator valves (TRVs), circulation of air or heat around the house by opening or closing internal doors and airing of the house by opening windows or trickle vents during the day or at night. The analysis draws out differences in the attitudes of the householders towards use of the heating system and expectation of the indoor climate. Despite similar dwellings, the measured annual energy usage varied by 360 %.

Two further examples of qualitative studies in pursuit of insight into energy efficiency or comfort practices are Judson and Maller (2014) and Madsen (2014). In a study by Madsen (2014), interviews were undertaken within the dwellings for a broad range of householders with varying behavioural and housing factors. Participants were split according to house age, occupant age (early 30s to late 60s), gender (11 women, 6 men) and family types (single occupant, family with children, couple without children), education level or income. Interviews were semi-structured, with a flexible thematic structure but also taking the form of a conversation. The interviews were recorded, transcribed and coded in relation to aspects of comfort so as to identify similarities between the individual stories. The benefit

of semi-structured interviews is that a rich data set can be collected, uninhibited by boundaries of pre-set questions and therefore more details are gained. In both studies, interviews were supplemented with a 'home tour' or 'go-along' (Kusenbach 2003) including photo documentation in most cases. Walk-through home tours allow for the interview material to be enriched by seeing the actual infrastructure being talked about, prompt householders to elaborate on their household practices in the context in which they are undertaken, and allow for cross-checking of the reported practices with evidence of actual practices. By asking for a home tour during the interview rather than before the interview, Judson and Maller (2014) found that it reduced the potential bias caused by homeowners preparing their homes for the tour.

Quantitative studies of heating practices have been undertaken which involve using sensors to measure heating related aspects of temperature and occupancy. The 'Carbon Reduction in Buildings Home Energy Survey' (CaRB HES) (Shipworth et al. 2010) commenced in 2007 with the monitoring of temperatures in living rooms and bedroom in 427 study homes, selected through stratified random sampling. In addition, information about central heating settings was reported by participants, along with building, technical, and behavioural data during structured interviews. During the interviews householders were asked if they would accommodate two temperature sensors for a year – one in the main living room and one in the main bedroom. Temperature data was collected for every 45 minutes over a six month monitoring period covering summer and winter. The temperature sensors (Hobo UA- 001-08) were small (about the size of a matchbox), silent and unobtrusive and placed in position by the householder or interviewer as guided by an instruction leaflet. Data was used to estimate average thermostat setting and the estimated average daily hours of active central heating use. The same data set was analysed by Huebner et al (2015; 2013) in their investigation of temperature profiles in living rooms and by Yang et al. (2015) to investigate the role of attitudes on home energy use behaviours. A similar data set was collected within the 4M ('Measurement, Modelling, Mapping and Management') project in which temperature data was recorded at hourly intervals over nine months in over 300 homes in Leicester, UK (Lomas et al. 2010). Temperature measurements were taken in the living room and bedrooms as well as household data, including socio-demographic information through structured face to face interviews. This data was used to investigate variations in indoor temperatures and heating practices (Kane 2013; Kane, Firth, Lomas, et al. 2011; Kane, Firth, Allinson, et al. 2011; Kane et al. 2010; Lomas & Kane 2013) and to validate building modelling software by comparing four of the measured houses with model predictions of energy performance (Duran 2013).

Sensing the occupancy of people in a house is more complicated and has been attempted in a range of ways such as wearable sensors and fixed sensors. Wearable sensors were

investigated in a study by Spataru et al. (2010) in which occupants wore compact tags. The signals of the tags were picked up by static sensors arranged around the house in order to track each occupant's 3D location. Gautier and Shipworth (2014) used wearable sensors to investigate occupants' reaction to feeling thermal discomfort (too cold). The sensors were made up of temperature sensor, light intensity and light-colour sensor, a passive infrared detector, a tri-axis accelerometer and a magnetometer. The sensors were also prompted to take a photograph every time one of the sensed parameters changed and at periodic time intervals. The accelerometers were able to sense movement and the change of location within the house was confirmed with the corresponding photograph. Fixed sensors were investigated by Ekwevugbe (2013) who developed an advanced instrumentation strategy to monitor occupancy levels in non-domestic buildings. The instruments combined CO<sub>2</sub> level sensors, temperature sensors, sound level sensors, foot pressure sensors and light dependent resistors LDRs at each door way. Through sensor fusion (combining the data from these sensors), an occupancy profile was produced for an office space. Love (2014) attempted to monitor occupancy levels in different rooms of a house using a sensor made up of two passive infrared sensors (PIRs). The door threshold was deemed to have been passed if both PIRs were triggered within a short specified time. However, various difficulties were experienced such as signal noise, calibration of delay time and internal clock malfunction, and therefore the occupancy sensors did not work as well as anticipated.

Ideally, both qualitative and quantitative options for data collection would obtain the same snapshot of behaviours or practices, however, Love (2014) found that the verbal responses given were not always consistent with measured data. For example, post retrofit, one interviewee stated that a change he had made was no longer putting on heating in the morning, describing that since the improvement of insulation, heat was retained better and therefore the internal temperature in the morning was higher already. However, the results from the temperature sensors showed that the probability of the heating being put on in the morning was higher post retrofit. A difference between reported and measured behaviour was also found by Gautier and Shipworth (2014) in their exploration of occupants' response to thermal discomfort; the most common reported response was to 'put on an item of clothing', whereas the most common measured response was to change body position, location or room. These findings demonstrate the difficulties of deriving realistic occupancy profiles for use in modelling.

### **2.3.3 Evidence of occupancy behaviour**

The theories and methods discussed above have been used for studies in the literature to gain insight into heating behaviours and patterns for different types of household occupants. Initially a review is presented of what are considered heating behaviours and

this is followed by empirical evidence of occupancy patterns and indoor temperatures. Subsequently, insight is presented into use of technologies by occupants (relating to control of heating and ventilation) and adoption of technologies as part of larger retrofit events.

### *2.3.3.1 Heating behaviours*

Studies of empirical evidence have shown that the technology in place in a house does not determine what heating practices are carried out and that despite highly efficient and low carbon technologies having been put in place, occupants are seen to rely on alternative, more familiar practices to attain the same service. Examples of this are the use of secondary heating rather than engaging with heating system controls (Chiu et al. 2014), or opening windows rather than using advanced mechanical ventilation with heat recovery technologies (Behar & Chiu 2013).

A search has been undertaken by the author on Web of Science using the key words “heating behaviour\*” (\* denotes any ending can be used), “house OR domestic OR residential” and “occupant” (search conducted on 29-1-16). Eighty eight results were returned of which 22 were deemed to include aspects of occupants’ domestic heating behaviours, either through empirical studies of observing heating behaviours, or including aspects of heating behaviours in modelling. The results of the review are presented in Table 2-3 which shows choice of temperature set-point, occupancy/heating pattern, use of heating controls and window opening as the most commonly referred to heating behaviours.

*Table 2-3 Review of literature reported 'heating behaviours'*

Heating related practice / behaviour	Number of studies	References
Temperature set-point	17	1, 2, 3, 4, 5, 6, 9, 11, 12, 13, 14, 16, 18, 19, 20, 22, 23
Length of heating period / time for which occupant present in home / time at highest set-point	14	1, 2, 3, 5, 6, 8, 13, 14, 18, 19, 20, 21, 22, 23
Interaction with thermostat / thermostat management (including type of temperature control)	9	5, 12, 13, 14, 16, 17, 19, 21, 23
Window opening	9	5, 10, 11, 12, 15, 16, 18, 22, 23
Proportion of house heated	7	4, 6, 13, 19, 20, 21, 23
Use of secondary heating	4	5, 15, 17, 21
Internal door opening	3	7, 18, 23
Personal heating (extra clothing, having a warm drink, having a bath when cold)	3	15, 17, 23
Length of heating season	2	20, 21
Varying heating between rooms	2	5, 23
Interaction with blinds (blocking natural light)	1	12
Closing curtains (for reducing heat loss)	1	17
Monitoring energy usage	1	23
Airing of house (purge ventilation)	1	23
1:(Guerra-Santin et al. 2009); 2: (Firth et al. 2010); 3: (Guerra-Santin & Itard 2010); 4: (Steemers & Yun 2009); 5: (Audenaert et al. 2011); 6: (Korjenic & Bednar 2011); 7: (Pilkington et al. 2011); 8: (Guerra-Santin 2012); 9: (Hiller 2012); 10: (Behar & Chiu 2013); 11: (Blight & Coley 2013); 12: (Fabi, Andersen, Corgnati, et al. 2013); 13: (de Meester et al. 2013); 14: (Motuziene & Vilutiene 2013); 15: (Chiu et al. 2014); 16: (D'Oca et al. 2014); 17: (Gauthier & Shipworth 2014); 18: (Silva & Ghisi 2014); 19: (Wei et al. 2014); 20: (Daniel et al. 2015); 21: (Huebner, Hamilton, et al. 2015); 22: (Majcen et al. 2015); 23 (Gram-Hanssen 2010)		

### 2.3.3.2 Patterns of occupancy

Many studies have been focussed on generating realistic occupancy patterns for the purpose of more accurate building energy modelling or policy design for consideration of different types of people. Typically these fall into two categories: generation of patterns based on statistical algorithms, and determination of archetypes. The statistical algorithm type approach, also known as stochastic models, is typified by the model developed by Richardson et al. (2008). They compiled a model capable of generating a realistic occupancy profile of 'active occupants' (in the house and not asleep) which showed good likeness to the aggregated measured data. The model uses a Markov-Chain technique which determines the state (active or not active) of the next ten minute time step based on the current state and the probability that the state will change (transition probability). The transition probability is calculated for each ten minute interval of a 24-hour day based on data from the UK Time-Use Survey conducted in 2000 (Short 2003). Other similar models have been created, in some cases differentiating between three states (at home and awake,

sleeping, absent) (Widén et al. 2009; Aerts et al. 2014; McKenna et al. 2015) and including activities or appliance use to better simulate energy use within the house (Widén & Wäckelgård 2010; Richardson 2010). As well as the UK Time-Use survey, the 2005 Belgian time-use survey has also provided useful data (Glorieux & Minnen 2008).

For the determination of archetypes approach, occupancy profiles have been derived from knowledge of typical or common household occupancy patterns in UK or Northern Europe (Yao & Steemers 2005; de Meester et al. 2013; Motuziene & Vilutiene 2013). Aerts (2014) combined the two approaches to identify seven realistic occupancy patterns from the statistical model as described above. Huebner et al (2015) used cluster analysis to identify four patterns of living room temperature, and although not attributed to a household profile archetype, these give empirical backing to those based on typical patterns. Table 2-4 shows the occupancy profile archetypes of the above mentioned publications.

*Table 2-4 Household occupancy patterns used in literature*

Publication	Method	Clusters / Archetypes
<b>Yao &amp; Steemers (2005)</b>	Five most common scenarios of household occupancy pattern were proposed	1) Part-time working (morning) (09:00-13:00), 2) Full-time working (9:00–18:00), 3) Part-time working (9:00–16:00), 4) No working, 5) Part-time working (afternoon) (13:00-18:00).
<b>Motuziene &amp; Vilutiene (2013)</b>	Three realistic occupancy profiles (for northern European households) were created as alternatives to the standard occupancy profiles given in the DesignBuilder model	1) 4 person: based on DesignBuilder, 2) 4 person: working parents and 2 children, 3) 2 person: actively working couple, 4) 2 person: retired couple.
<b>De Meester et al. (2013)</b>	Based on state-of-the-art, predominant household characteristics were combined into four types of family composition with two duration of presence at home	1) Active couple with 3 school children, 2) Stay at home couple with 3 school children, 3) Active couple (full and partial occupancy), 4) Retired couple (full and partial occupancy).
<b>Aerts et al. (2014)</b>	Developed seven typical occupancy patterns generated in their occupancy model based on data from the 2005 Belgian time-use survey.	1) Mostly absent, 2) Mostly at home, 3) Very short daytime absence, 4) Night time absence, 5) Daytime absence, 6) Afternoon absence, 7) Short daytime absence.
<b>Heubner et al. (2015)</b>	Analysis of the temperature profiles of 275 living rooms. Through cluster analysis, four profiles were found	1) Steady rise, 2) Flat line, 3) Two peak, 4) Steep rise

### 2.3.3.3 Indoor temperature

Published studies of measured internal temperature have shown winter average temperatures in the range 18 °C to 20 °C in the living room and 15 °C to 19 °C in the bedroom, (Yohanis & Mondol 2010; Kane 2013; Hunt & Gidmant 1982; Oreszczyn et al. 2006; Summerfield et al. 2007; Kelly et al. 2013). However, average temperature

measurements include both heated and un-heated times of day, and do not represent temperature demand. Shipworth et al. (2010) estimated a mean thermostat setting of 21.1 °C (standard deviation = 2.5 °C) from temperature loggers in 427 study homes across the UK (a temperature which was significantly higher than the thermostat settings reported by the residents, which had a mean of 19.0 °C). Kane identified a wide range of average temperatures during the evening heating period, with 15 % of dwellings at 15 °C or lower and 11 % of dwellings at or above 23 °C. Recommended minimum dwelling temperature in England is 18°C in winter, exposing minimal risk to the health of a sedentary person, wearing suitable clothing (PHE 2014), however the internal temperature can be lower during the night-time due to additional thermal resistance of bed sheets.

### 2.3.3.4 Use of technologies

Hormazabal et al. (2009) investigated the experience of occupants of a low energy house (the BASF house, Nottingham, UK). With a range of energy efficiency technologies, such as biomass boiler, solar hot water, ground source heat pumps and natural ventilation system, user interaction was important and was enabled through a screen in the kitchen. However, it was found that even occupants with a technical engineering background and some degree of pro-environmental concerns could not work the technologies within the house correctly, resulting in energy wastage, low comfort levels and several hours of engineer and technician's time. These results demonstrate the importance of household knowhow and appropriate controls as the interface between occupants and technologies.

Peffer et al. (2011) reviewed literature on the use of thermostats in homes, finding that programmable thermostat temperatures tend to be higher than manual thermostats, and that in one survey in California by thermostat manufacturer Carrier, 53 % of programmable thermostats were in 'hold' mode in which they were being used as a manual control. Fabi et al (2013) monitored the adjustment of thermostatic radiator valves (TRVs) by occupants in 13 houses in Denmark over a six month period. A wide variation in heating control adjustment behaviour was found, with the number of occupant interactions with heating controls in a six month period ranging from 0 to 106.

Wei et al. (2014) identified 27 factors which influence occupant's control of space heating in residential buildings and these were divided into categories; *environmental factors* (outdoor climate and indoor relative humidity), *building and system related factors* (dwelling type, dwelling age, dwelling size, room type, house insulation, type of heating system, type of temperature control, and type of heating fuel), *occupant related factors* (occupant age, occupant gender, occupant culture/race, occupant education level, social grade, household size, family income, previous dwelling type, house ownership, thermal sensation, perceived

indoor air quality, perceived noise, and health), and *other factors* (time of day, time of week, occupancy, heating price, and energy use awareness). The effect on space heating of some of these factors had been studied and widely accepted, whereas others were identified as requiring further investigation. When considering the representation of each factor in building modelling through a literature review of building performance simulation studies, five of the factors were commonly used to describe heating behaviour (occupancy, outdoor climate, time of day, room type and indoor relative humidity), many other factors were used for the modelling of other input categories in the building performance simulation, and a remaining ten were typically ignored in the building performance simulation. It was recommended that although inclusion of all factors would overburden the resources and time required for the building performance simulation process, discussion of the influence of other factors on the simulation result should be included.

Combe et al. (2011) investigated usability of heating controls and how heating control design influenced the degree of 'user exclusion' by considering 'vision', 'thinking' and 'dexterity' requirements. Using the 'Design Exclusion Calculator' developed at the University of Cambridge, they found that current design placed excessive demands upon the capabilities of at least 9.5 % of the UK population over 16 years old, rising to 20.7 % for users over 60 years old. Additional constraint was expected with the inclusion of levels of numeracy and literacy, which were not accounted for in their method. These results were validated through usability testing in which 66 % of users at a low carbon housing development could not programme the controls as required.

With regards to ventilation technologies, Behar & Chiu (2013) undertook a study of how three households interacted with three different innovative systems; passive stack ventilation, mechanical extract ventilation, and mechanical ventilation with heat recovery (MVHR). The qualitative approach involved a 'walkthrough' of the house to understand occupants experience with and use of the technologies. For one occupant, a good general technical competency was not sufficient to ensure the correct usage of the ventilation system and he was confused about how the system worked. Despite having an understanding of the air tight design of the home he was found to have a bedroom windows open with the thermostat set at 22 °C, using windows to 'freshen up' the rooms. Other occupants demonstrated their lack of understanding of how the system worked through visible obstruction of trickle vents in the bedrooms and extraction vents in the kitchen. For one occupant, an experience of overheating when they first moved into the house led to frustrations with a perceived lack of control, which was resolved with the provision of a pole to open skylights. The ability of the household to adapt to a technology such as innovative ventilation was concluded to depend on technical knowledge, access to



help to overcome challenges posed by the technology, and the way in which occupants 'make sense' of a technology when they first encounter it.

### 2.3.3.5 *Retrofit events*

Adoption of larger measures such as insulation, windows and boiler can be seen as retrofit events. Gram-Hanssen (2014) investigated energy related renovation of existing buildings in Denmark. She found that aesthetic related retrofits were commonly a higher priority for householders than energy efficiency related renovations as householders liked to have something to display and see these as more 'fashionable'. The motivations for renovations were about life-style vs wear and tear and varied between the desire to achieve a result (product) or to undertake a project. Friege and Chappin (2014) performed a citation network analysis in their quest to understand what is needed to sufficiently increase the number of domestic energy efficient renovations and identify potential research gaps. Their literature was found to cover four main areas: 'technical options', 'understanding decisions', 'incentive instruments' and 'models and simulations'. They found that although literature on energy efficient renovations gained considerable momentum in the past decade, much of it lacked a deep understanding of uncertainties surrounding economic aspects and non-economic factors driving the renovation decisions of householders. The analysis indicated that economic drivers (energy saving potential and profitability of energy efficiency measures) were less important than generally expected and that homeowners' decisions are shaped by non-economic goals which are insufficiently accounted for in calculations. This explains why existing initiatives which typically target the economic viability of measures have fallen short of their expected success. Energy Performance Certificates provide specific recommendations for cost effective energy efficiency improvements and therefore address the barrier to retrofit posed by lack of information, however Christensen et al (2014) found that the EPC has a limited influence on homeowners' energy retrofit practices. Despite most homeowners finding the EPC reliable and easy to understand, relatively few find it useful as a source of information for home retrofits.

Bartiaux et al (2014) investigated whether energy retrofit is a 'social practice' by considering 60 cases from four European areas which have different geography, culture and housing contexts but all regulated under the same European Performance of Buildings Directive. They concluded that retrofit couldn't currently be considered a practice as the retrofit events were not sustained by common and conventional routines, or by shared know-how and goals amongst relevant actors. They recommend that the target of energy retrofit related policies should be the social context of energy retrofit rather than individuals themselves. In contrast, Judson and Maller (2014) judged that energy retrofit is a practice

and found that energy efficiency requirements of housing are negotiated at the household level, whether during renovation or in the normal daily lived experience of home owners. They argue that by conceptualising home renovations as renovation practices and by highlighting the practices of daily life with which they interact and are mediated by, further and potentially more fruitful avenues for interventions to reduce greenhouse gas emissions will be revealed. The belief in a need to consider the intersection of households' everyday practices and renovation practices was shared by Wilson et al. (2015) who advocate that considering ultimate, proximate and immediate influences on energy efficiency renovation decisions (relating to initial decision process of why a household would renovate, how and what to renovate, and which renovation products to use, respectively) enables greater understanding of why households make the decisions they do. Vlasova & Gram-Hanssen (2014) compared three different approaches to energy efficiency retrofit; a DIY case led by the homeowners, a commercial case as part of a wider project and a case led by an ESCo. A 'context-rich' retrofit approach (in which an understanding of future practices of homeowner influenced the plan for the work) was found to be most successful for reducing energy consumption post retrofit. Successful projects also incorporated a 'context-bound' approach with the inclusion of a feed-back loop for how the retrofitted house is expected to influence the everyday practices of the family. All of the studies conclude that if the sole focus of retrofit policies is to slot technical interventions into homes then these policies will only have a limited effect and impact on energy consumption reduction (Judson & Maller 2014; Wilson et al. 2015; Vlasova & Gram-Hanssen 2014).

### **2.3.4 Categorisation of occupants**

In order to understand the suitability of technologies to households, categorisation of people allows technology attributes to be matched to aspects of personality or lifestyle which would enable best performance. Similar to the identification of different occupancy profiles as presented in Table 2-4, archetypes for household approaches to energy usage and retrofit have been identified in literature and are given in Table 2-5. The earliest example of energy behaviour archotyping was Van Raaij and Verhallen (1983) who identified five behavioural patterns for temperature and ventilation based on self-reported behaviours of 145 households in Vlaardingen, the Netherlands. They found that energy use of these clusters differed considerably. Guerra-Santin (2011) undertook similar research and identified five behavioural patterns based on clusters derived from a survey (313 returned questionnaires) in two districts in The Netherlands. The questionnaire gathered details of building characteristics, household characteristics and occupant behaviour. Zhang et al. (2012) identified three attributes which contribute to residential energy use; property energy efficiency level, greenness of behaviour and duration of daytime occupancy. By considering these as three dimensions, eight archetypes for resident behaviour were

identified. Haines and Mitchell created a user-centred design approach to energy demand reduction. Archetypal personas were created based on behavioural and demographic variables: getting the job done (DIY or pay others), trust in professionals (low or high), tolerance of disruption (low or high), hunger for information (low or high), interest in energy savings (low or high). The personas represent attitudes and motivations around homeowners making improvements to homes, difficulty related to making home improvements, how homeowners go about making improvements and how the attitudes, motivations and behaviours result in opportunities and barriers to retrofit.

*Table 2-5 Household archetypes for energy related behaviour*

Publication	Method	Clusters / Archetypes
<b>Van Raaij &amp; Verhallen (1983)</b> <i>Energy related behaviour</i>	Cluster analysis of behaviour patterns based on home temperature (whilst present and absent) and ventilation (airing rooms and use of hall door) from self-reported behaviour of 145 households in Netherlands	<b>1) Conservers</b> , use less energy than average – low ventilation, low temperature <b>2) Spenders</b> , use more energy than average - high ventilation, high temperature <b>3) Cool</b> , use less energy than average – high ventilation, low temperature <b>4) Warm</b> , use less energy than average – low ventilation, high temperature <b>5) Average</b> , medium ventilation, medium temperature
<b>Guerra-Santin (2011)</b> <i>Behaviours affecting energy spent on heating</i>	Statistical analyses based on a household survey carried out by the OTB Research Institute. Behavioural patterns were based on five factors: Use of appliances and spaces, energy-intensive, Ventilation, Media, Temperature comfort	<b>1) Spenders</b> , no energy-saving concern, high use of all factors <b>2) Affluent-cool</b> , more use of space and more hours of ventilation <b>3) Conscious-warm</b> , use of more space, more hours of heating, more use of electronics, fewer hours of ventilation <b>4) Comfort</b> , more use of electronics, more hours of heating, more hours of ventilation <b>5) Convenience-cool</b> , more use of electronics, more hours of ventilation
<b>De Groot et al. (2008)</b> , <i>Drivers for energy behaviours</i>	Identification of drivers for energy consuming and/or saving behaviour with the intention of creating a probabilistic tool for energy performance calculations in which the archetypes are used to create fixed behavioural profiles  <i>(archetypes also used by Paauw et al. (2009))</i>	<b>1) Convenience / Ease</b> , comfort as main driver of behaviours <b>2) Conscious</b> , behaviours driven by comfort, but take cost and environment into consideration <b>3) Costs</b> , behaviours mainly to save energy to reduce cost <b>4) Environment</b> , behaviours driven by concern for the environment
<b>DEFRA (2008)</b> <i>Pro-environmental behaviours</i>	Identification of seven clusters based on people's willingness and ability to act pro-environmentally. The clusters are based on responses to a broad range of attitudinal questions as part of Defra's attitudes and behaviours survey.	<b>1) Positive greens</b> , believe in the need to do something to tackle climate change, 'I do what I can, and feel bad about the rest' <b>2) Waste watchers</b> , 'waste not, want not' – believe you should think about what you're doing and using <b>3) Concerned consumers</b> , pro-environmental beliefs, unwilling to make certain sacrifices but feel guilty about doing so <b>4) Side-line supporters</b> , think climate change is important but this view does not impact their behaviours <b>5) Cautious participants</b> , do some things to help the environment and would do more, if other people do too <b>6) Stalled starters</b> , no concern for environment but low impact lifestyle due to other constraints (e.g. financial)

		7) <b>Honestly disengaged</b> , 'just living my life the way I want to' with no interest or concern in the environment
<b>Zhang et al. (2012)</b>	Three-dimensions of residential energy consumers in the UK identified. Archetypes based on three dimensional matrix of 'Greenness of behaviour', 'Energy efficiency level of the property' and 'Daytime occupancy period'. Energy policy/intervention implications of each of the archetypes was recommended based on technical and socio-economic options for enhancement of end-use efficiency and behavioural change by end-users, as well as the effectiveness of feedback on energy consumption	1) <b>Pioneer greens</b> , <i>high</i> greenness of behaviours, <i>high</i> energy efficiency of property, <i>short</i> daytime occupancy 2) <b>Follower greens</b> , <i>high</i> greenness of behaviours, <i>low</i> energy efficiency of property, <i>short</i> daytime occupancy 3) <b>Concerned greens</b> , <i>high</i> greenness of behaviours, <i>low</i> energy efficiency of property, <i>long</i> daytime occupancy 4) <b>Home-stayers</b> , <i>high</i> greenness of behaviours, <i>high</i> energy efficiency of property, <i>long</i> daytime occupancy 5) <b>Unconscientious</b> , <i>low</i> greenness of behaviours, <i>high</i> energy efficiency of property, <i>short</i> daytime occupancy 6) <b>Regular wasters</b> , <i>low</i> greenness of behaviours, <i>low</i> energy efficiency of property, <i>short</i> daytime occupancy 7) <b>Daytime wasters</b> , <i>low</i> greenness of behaviours, <i>high</i> energy efficiency of property, <i>long</i> daytime occupancy 8) <b>Disengaged</b> , <i>low</i> greenness of behaviours, <i>low</i> energy efficiency of property, <i>long</i> daytime occupancy
<b>Rubens &amp; Knowles (2013)</b> <i>Use of heating controls</i>	Research into how people use their heating controls and what they want from them. Categorise based on defining features of: cost vs comfort, single vs differentiated heated space, regular vs irregular heating, predictable vs unpredictable heating times, controlling for self or others. Reactions to three types of smarter control were explored: zonal control, remote control, automation	1) <b>Rationers</b> , minimising spending as priority, heating rationed to minimum, manual control of heating 2) <b>Ego-centric</b> , heating controlled according to how they felt, comfort as priority, manual heating control 3) <b>Hands off</b> , want to be warm when at home without interacting with heating, use controls allowing different temperatures set at different times, more regular routines and occupancy 4) <b>Planners</b> , thought ahead about when heating needed, tried to avoid waste, made anticipatory changes to controls to anticipate variable occupancy and routine 5) <b>Reactors</b> , tended to be larger homes with some rooms warmer and some cooler, reacted to internal and external variations in temperature using controls and auxiliary heating
<b>Haines &amp; Mitchell (2014)</b> <i>Domestic energy retrofit</i>	The personas represent attitudes, motivations and levels of competency around homeowners making improvements to their homes. Archetypal personas were created based on behavioural and demographic variables: Getting the job done (DIY or pay others), Trust in professionals (low or high), Tolerance of disruption (low or high), Hunger for information (low or high), and Interest in energy savings (low or high).	1) <b>The idealist restorer</b> : the property is a project 2) <b>The affluent service seeker</b> : the property is a pleasure 3) <b>The property ladder climber</b> : the property is a step up 4) <b>The pragmatist</b> : subtype – functional: the property in a place to live 5) <b>The pragmatist</b> : subtype – aesthetics: the property is a home 6) <b>The stalled</b> : subtype – lack of finance: the property is a shelter 7) <b>The stalled</b> : subtype – pressures of life: the property is a necessity
<b>Watson &amp; Shove (2008) (Tools sales person)</b> <i>Approach to DIY</i>	Perception of one individual. Based on attributes of DIY experience, confidence to carry out DIY and satisfaction gained from the process	1) <b>Confident enthusiast</b> : DIY experience and continued enthusiasm for DIY jobs at home 2) <b>Pragmatists</b> : experience and enthusiasm but find little reward in doing DIY jobs at present 3) <b>Newbies or Assurance seekers</b> : lack experience and confidence but want to achieve a desired effect 4) <b>Hobbyists or Careful perfectionists</b> : not necessarily having experience but driven by pursuit of craft ideals and concerned as much by process as final result

## 2.4. Domestic retrofit

Within this section of the literature review, the issue of building retrofit is examined, beginning with a review and analysis of energy efficiency technologies as taken from a broad range of literature. This is followed by an explanation of the UK's retrofit challenge and the landscape of domestic energy efficiency policies. Finally, the review turns to barriers to retrofit and broader challenges to energy efficiency as presented by the energy performance gap.

### 2.4.1 Energy efficiency technologies

A review has been undertaken by the author of technologies and energy efficiency measures recommended for building energy efficiency retrofit. The sources used are a range of industrial (CIBSE 2012; Passive House Institute 2013; Petersdorff et al. 2002) and policy documents (DECC 2012b; Lowe et al. 2011; Palmer et al. 2012) applicable both to general and specific recommendations, academic papers (Anastaselos et al. 2009; Ardenne et al. 2008; Baetens et al. 2011; Intini & Kühtz 2011; Papadopoulos & Giama 2007; Pargana 2012), books (Harvey 2010; Lovins 2011) and reports from individual energy efficiency retrofit projects (Bristol Green Doors 2013; Parity 2012). In total, 147 recommendations are gained from these sources, including 138 unique options. In an attempt to gain a coherent understanding of how these technologies contribute to delivering energy service with greater energy efficiency, the technologies have been clustered according to the service (and sub-service) they deliver. The results of this analysis is presented in Table 2-6 and enables technology alternatives to be identified and compared.

**Table 2-6** Energy efficiency technologies and measures identified in literature (Anastaselos et al. 2009; Ardenne et al. 2008; Baetens et al. 2011; Bristol Green Doors 2013; CIBSE 2012; DECC 2012b; Harvey 2010; Lovins 2011; Lowe et al. 2011; Papadopoulos 2005; Pargana 2012; Palmer et al. 2012; Parity 2012; Passive House Institute 2013; Petersdorff et al. 2002)

Energy service		Technologies
Thermal comfort	Heat generation	Efficient heat generation: <i>High efficiency gas condensing hot water boilers, Furnaces, Electric-resistance heating, Fan-assisted replacement storage heaters, Oil-fired condensing boilers</i> ; Alternative types of heating technologies: <i>Radiant heating, Secondary / Portable heaters</i> ; Renewable fuel: <i>Biomass room heaters (including with radiators), Biomass/biofuel boilers</i> ; Heat pumps: <i>Air source heat pumps, Ground source heat pumps</i> ; On-site cogeneration: <i>Micro CHP</i> ; Solar hot water: <i>Flat plate solar hot water collectors (roof), Transpired solar collectors</i> ; Windows: <i>Direct (solar) gain, Smart windows (thermochromatic), Air flow windows</i> ; Building design to optimise solar gains: <i>Orientation, Proportion of Glazing</i> .
	Heat delivery and control	Methods of heating delivery: <i>Under-floor heating, Warm-air units, Hot water systems (efficient)</i> ; Hot water controls: <i>Cylinder thermostats, well insulated water cylinders, weather compensator for combi boiler</i> ; Heating controls; District heating; Variable speed drives for fans and pumps.
	Heat retention	Types of insulation: <i>PIR (25-100mm), Solid foam panels, Fibreglass insulation batts, Mineral fibre batts, Blown-on foam insulation, Blown-in loose cellulose, Sprayed adhesive cellulose fibre, Other wood-based fibre products, Aerogel, Vacuum insulation panels</i> ; Locations for insulation: <i>Cavity wall insulation (including Hard-to-treat), External wall insulation systems, Internal wall insulation systems, Under-floor insulation, (mineral wool below suspended ground floor (150mm)), Roof insulation: Attic internal insulation, Room-in-roof insulation, Loft or rafter insulation (including loft hatch insulation)</i> ; Improved airtightness: <i>Draught proofing, draught lobby, Professionally draught proof the front door, Sealing improvements (including duct sealing)</i> ; High performance external doors; Windows: <i>Replacement glazing (building regulation standard double glazing, triple glazing, Secondary glazing), Proportion of Glazing</i> ; Water system insulation: <i>Hot water cylinder insulation, Pipe-work insulation, Duct insulation</i> ; Ventilation with efficient heat recovery: <i>Mechanical ventilation with heat recovery, Flue gas heat recovery devices</i> ; Minimisation of thermal bridges; Phase-change materials; Thermal Mass.
	Cool generation	AC and electric chillers: <i>absorption chillers, desiccant dehumidification and associated cooling systems</i> ; Air-conditioning controls (including zoning controls), Harnessing external 'coolth': <i>heat pumps, use of cool groundwater</i> ; Underground earth-pipe cooling; Enhanced evaporative cooling; Shading devices: <i>Solar blinds, Shutters</i> ; Building design: <i>design to reduce load, double skin façade</i> .
	Heat removal	Heat removal technologies: <i>Cooling towers, Desiccant dehumidification and associated cooling systems, Evaporative cooling, Heat pumps</i> ; Ventilation: <i>Natural ventilation, Hybrid natural and mechanical ventilation, Night-time passive and mechanical ventilation, Air flow windows</i> .
	Air movement	air flow windows, ceiling fans, cooling towers, Hybrid natural and mechanical ventilation, night-time passive and mechanical ventilation, Variable speed drives for fans and pumps, Ventilation, Ventilation controls (including zoning controls)
	Air removal	air flow windows, cooling towers, Flue gas heat recovery devices, heat recovery ventilators, hybrid natural and mechanical ventilation, Mechanical ventilation with heat recovery, natural stack ventilation, natural ventilation, night-time passive and mechanical ventilation, Variable speed drives for fans and pumps, Ventilation, Ventilation controls (including zoning controls), Ventilation with efficient heat recovery
	Humidity control	Desiccant dehumidification and associated cooling systems.

<b>Sustenance</b>	<b>Food cooking</b>	Heat-trapping pots, Replace electric oven with a gas oven, Replace old gas hob with a new gas hob, smarter electric stove.
	<b>Water heating</b>	Electric to eco kettle, Efficient condensing hot water boiler, Micro CHP, Biomass (pellet) burning boilers, Heat pumps, Hot water cylinder insulation; Solar water heating: <i>Flat plate solar hot water collectors, Transpired solar collectors</i> ;
	<b>Water delivery</b>	Duct insulation, Hot water controls (including timers and temperature control), Hot water cylinder insulation, Hot water taps (efficient), Pipe-work insulation, Sealing improvements (including duct sealing), well insulated water cylinder
	<b>Cold storage</b>	Chillers, Enhanced evaporative cooling, fridge-freezer A++ rating
<b>Hygiene</b>	<b>Water heating</b>	Efficient Hot water systems; <i>top spec gas condensing hot water boiler</i> ; Renewable heat generation: <i>Water source heat pumps, Biomass (pellet) burning boilers</i> ; Micro combined heat and power; Solar water heating: <i>Flat plate solar hot water collectors, Transpired solar collectors</i> ; Hot water cylinder insulation, Hot water controls: <i>timers and temperature control, weather compensator for combi boiler</i> ; Waste water heat recovery devices attached to showers.
	<b>Water transportation</b>	Hot water cylinder insulation, Variable speed drives for fans and pumps, weather compensator for combi boiler, well insulated water cylinder
	<b>Water delivery</b>	Duct insulation, Hot water cylinder insulation, Hot water showers (efficient), Hot water taps (efficient), Pipe-work insulation, Sealing improvements (including duct sealing), standard non-electric shower, ultra-low flow shower head, well insulated water cylinder
	<b>Clothes cleaning</b>	Only use the washing machine at 30 degrees
<b>Illumination</b>	<b>Light generation</b>	LEDs, Orientation, Proportion of Glazing, Good quality windows
	<b>Luminaire design</b>	Lighting systems, fittings and controls (including roof lights, lamps and luminaires)
	<b>Light system design</b>	Lighting systems and controls, Lighting systems, fittings and controls (including roof lights, lamps and luminaires)
<b>Other (Power)</b>	<b>Electricity generation</b>	Use of renewable energy sources: <i>Micro wind generation, Photovoltaics (PV) array (1.5kWp)</i> ; On-site cogeneration: <i>CHP</i> .
	<b>Electrical efficiency</b>	Appropriate controls and Building Management System, Do not leave any appliances on standby, Fibonacci Rotors, High efficiency motors and variable speed drives, Metering, voltage optimisation to drop mains voltage to 220V.

### 2.4.2 Domestic energy efficiency policies

The past decade has seen a variety of policies and programmes brought in to improve the energy performance of domestic buildings. These range from minimum energy efficiency standards for both new builds and existing buildings, funding mechanisms for retrofit work, requirements on energy efficiency reporting and mechanisms for supporting low carbon energy generation. In recent years the UK has seen a shift of government policy away from financial support programmes to solely capacity building, accreditation and compliance monitoring (Mallaburn & Eyre 2014).

### 2.4.2.1 *Domestic energy efficiency standards*

**New buildings:** *Building regulations (1985 – present), Code for sustainable homes (2007 – 2015), Home Quality Mark (2015 – present), Zero carbon homes (Launched 2006 to apply in 2016, (cancelled in 2015)).*

Since 1985, UK Building Regulations have included minimum standards for energy efficiency, predominantly focussed on limiting the heat loss of building fabric; these exist in Part L. There has been continual tightening of minimum standards with progressive updates to the regulation. The Zero Carbon Homes policy, introduced in 2006 and originally planned for implementation in 2016, was a requirement for all new homes to have net zero carbon emissions through fabric energy efficiency and on site low or zero carbon heat and power generation. However, due to the political rhetoric around the need for a sharp increase of the number of new houses to be built, the requirement was withdrawn in July 2015 over concerns that it would create a barrier to new home building (HM Treasury 2015). This decision received heavy criticism from the building industry and environmental groups (Oldfield 2015; UK GBC 2015). The Code for Sustainable Homes was a voluntary standard based on the sustainability of new homes as measured against nine categories of sustainable design (rating from level 1 to level 6) which enabled ambitious energy efficiency levels of new homes to be recognised. The Code for Sustainable Homes was withdrawn by UK Government in 2015, with some standards consolidated into building regulations. In response to the winding down of Code for Sustainable Homes, the Building Research Establishment (BRE) has launched the Home Quality Mark to help house builders demonstrate the high energy performance of their homes.

With regards to retrofit, Part L1B of the building regulations refers specifically to conservation of fuel and power in existing dwellings, including requirements for U-values of thermal elements of buildings where more than 50 % of the element's surface area is being renovated. In 2012, the UK Government's Department for Communities and Local Government (DCLG) published a consultation paper on reforms to building regulations regarding improvements to existing buildings, named the 'consequential improvements' rule. The rule would require that any home undergoing improvement work (such as extensions or loft conversion) would also have to implement energy efficiency improvements such as wall or loft insulation, even if these are not related to the work being planned. The rule was dubbed as the 'conservatory tax' by some media outlets (BusinessGreen 2013) and was not implemented due to concerns by Government Ministers that it would discourage people from undertaking home improvements.



### 2.4.2.2 *Energy efficiency rating*

*Energy Performance Certificates (Aug 2007 – present), Appliance energy labels (2010 – present)*

Energy efficiency ratings have been introduced in order to give an indication to home buyers and customers of the energy efficiency of the homes or appliances they are buying. Appliance energy labels provide a rating of energy consumption and performance of domestic appliances (washing machine, refrigerator, dishwasher, television); initially the rating related to an A-G scale but additional levels of A+ to A+++ have been introduced to signify the improvement of energy efficiency. Energy Performance Certificates for dwellings include a rating based on a survey of energy efficiency factors (e.g. loft insulation, boiler, hot water tank, windows and lights). A steady state calculation based on the Standard Assessment Procedure (SAP) returns a single number rating, between 100 (good performance) and 0 (poor performance), of the calculated performance of a house which translates into an A-G grading for both energy efficiency performance and environmental impact (CO<sub>2</sub> emissions). As well as a current rating, the Energy Performance Certificates display a potential rating based on cost effective upgrade measures. SAP has received criticism for not being an adequate measure of building energy efficiency but instead representing cost effective performance of buildings and therefore leading to perverse incentives which can result in increased CO<sub>2</sub> emissions (Kelly et al. 2012). An example is that a higher SAP rating can be achieved by switching heating fuel to coal from some other less carbon intensive fuel because coal is one of the cheapest fuels, but this change would result in an increase in CO<sub>2</sub> emissions (Kelly et al. 2012).

### 2.4.2.3 *Funding for energy efficiency retrofit*

*Warm Front (2000 – 2012/13), Carbon Emissions Reduction Target (CERT) (2008 – 2012), Community Energy Saving Programme (CESP) (Sept 2009 – Dec 2012), Energy Company Obligation (ECO) (Jan 2013 – present), Green Deal (Jan 2013 – July 2015), Boiler scrappage scheme (Jan 2012 – present)*

The first UK policy for energy efficiency retrofit was the Warm Front which was predominantly designed to address fuel poverty rather than climate change. Through Warm Front, funding was available to households in fuel poverty, specifically those on a low income and living in properties with poor insulation or without a working heating system. The main retrofit measures installed through Warm Front were replacement gas boilers, heating repairs and loft insulation. Between 2005 and 2013, over 1.5 million households were assisted by the Warm Front scheme with approximately 922,000 properties receiving at least one measure (DECC 2014d).

In recent years, the majority of funding for domestic energy efficiency retrofit work in the UK has come from the large energy companies (known as the 'Big Six') through obligations to help their customers to reduce carbon emissions. For CERT, a total saving of 293 million lifetime tonnes of CO<sub>2</sub> was required by December 2012, including specific targets for the Priority Group (people over 70 and on certain qualifying benefits) and for professionally installed insulation measures. CO<sub>2</sub> emission savings were calculated by deemed savings attributed to a wide range of measures and by the end of the scheme, a deemed saving of 296.9 million lifetime tonnes of CO<sub>2</sub> was achieved. CESP was an additional obligation aimed at low income areas of Britain, designed to promote a 'whole house' approach to energy efficiency retrofit.

CERT and CESP were replaced by the Green Deal and ECO in 2013 as a transition from a grant based approach to a market led alternative. The Green Deal represented a pay-as-you-save model whereby upfront cost barriers for energy efficiency retrofit were removed by loans which could be attached to the house and not the occupant. ECO funding was made available to supplement the cost of hard-to-treat measures and to provide additional grants for low-income households and vulnerable groups. Government funding for Green Deal loans was removed in July 2015, but ECO funding is still available.

Another important government funding initiatives for a specific technology is the boiler scrappage scheme which gave households money (£400 - £500) towards replacing an old 'G' rated boiler with a new 'A' rated boiler. The scheme has been run by each devolved administration, and in England, the full £50m available through the scheme was allocated between January 2012 and March 2012, enabling 118,000 households to upgrade their boilers (DECC 2011).

### *2.4.2.4 Smart meters*

#### *Smart meter roll out (2016 – 2020)*

Smart meters for domestic electricity and gas supply are being rolled out across the UK with a target of all households receiving one by 2020. Smart meters enable benefits of accurate billing and automated meter readings for utility companies and greater transparency of energy use for householders. Access to accurate electricity and gas data could enable significant other benefits such as more personalised advice for energy efficiency retrofit, evaluation of effectiveness of retrofit and improved methods for measurement and certification of building energy performance (Marshall 2015).

### 2.4.2.5 *Funding for low carbon energy*

*Feed-in-tariff (FiT) (April 2010 – present), Renewable heat incentive (April 2014 – present)*

FiT is a payments made to households for micro-generation of renewable electricity (solar photo voltaic (PV) array, wind turbine, micro CHP, hydro, anaerobic digestion) in order to incentivise the installation of such technologies. Two types of payments are made which are a generation tariff at a set rate for every kilowatt-hour of electricity generated, and an export tariff which is a further payment for any electricity which is generated but not used by the household and instead sold back to the grid. Renewable heat incentive is equivalent to FiT, but applied to heat generation (heat pump, solar thermal, biomass).

Payment per kWh generated have decreased as cost of technologies has reduced, as less subsidy is required to give the technologies a reasonable payback period. However, the scale of the reduction has led to a severe drop in new domestic installations of solar photo-voltaic panels, with a 74 % decrease in installed capacity between February and March 2016 compared to the same period in 2015 (Vaughan 2016). This reduction in support threatens to damage businesses within the domestic renewables industry (particularly solar installers) and has received criticism from environmental groups who fear that the long term deployment of low carbon energy generation is being compromised (Macalister 2015).

### 2.4.3 **Changes in energy efficiency of building stock**

These energy efficiency policies have started to have a significant effect on the energy performance of the housing stock, so the average Energy Performance Certification rating has increased from 42 in 1996 to 60 in 2013 (DCLG 2010; DCLG 2015), but there still exists a large discrepancy between types and ages of houses. In 2008, the average SAP rating was 50 for solid wall properties (those built before 1919), 61 for retrofitted cavity wall properties (those built between 1945 and 1965, before building regulations stipulated limits of thermal transfer for building envelope) and 70 for dwellings built with cavity wall insulation (those built since 1990) (DCLG 2010). In 2013, 68 % of homes with cavity walls were estimated to have been insulated (either built with insulation or insulation added) compared to only 7 % of houses with solid walls (DCLG 2015).

### 2.4.4 **Barriers to retrofit**

Energy efficiency policy focusses on overcoming barriers to retrofit, and the majority of policy initiatives in the UK have been directed at overcoming finance as a barriers. However, the cost of technologies is just one of many barriers to the adoption of energy efficiency technologies and measures.

#### *2.4.4.1 Barriers to energy efficiency as a priority*

A major barrier to engaging with any energy efficiency improvements is that people do not see energy efficiency improvements to their homes as a priority (Dowson et al. 2012; Steg 2008; Pelenur & Cruickshank 2012; Mallaburn & Eyre 2014; Tuominen et al. 2012). This may be despite a general concern for the environment and may be conflated by a person's feeling that they already 'do their bit' (such as recycling). For some, informational barriers exist about which energy efficiency measures are most appropriate to their homes (Steg 2008; Gilchrist & Craig 2014; Tuominen et al. 2012) especially if some measures have already been adopted. People may be sceptical about the level of energy saving which a certain energy efficiency measures will actually deliver (Dowson et al. 2012; Gilchrist & Craig 2014; Mallaburn & Eyre 2014). Studies have shown that homeowners are more motivated to undertake non energy efficiency related house renovation work (new bathroom, new kitchen etc.) (Gram-Hanssen 2014; Judson & Maller 2014; Galvin & Sunikka-Blank 2014), leading Wilson et al (2015) to advocate that energy efficient retrofit needs to be tied in with these other renovation events within the conditions of everyday domestic life.

#### *2.4.4.2 Financial barriers*

Financial barriers to energy efficiency retrofit are frequently identified despite most measures saving money over their lifetime, and upfront cost of energy efficiency measures is commonly listed as the main barrier to adoption (Gilchrist & Craig 2014; Pelenur & Cruickshank 2012; Mallaburn & Eyre 2014). Other financial barriers are uncertainty of attainable cost savings delivered by energy efficiency measures and the associated financial risk (Dowson et al. 2012; Mallaburn & Eyre 2014; Tuominen et al. 2012). A major barrier to the adoption of the UK's Green Deal was commonly cited as the high interest rate on the loan offered to pay for the costs and this high cost of finance is related to the uncertainty of technologies' performance. Another common financial barrier is often termed the landlord-tenant disconnect, presented as the split incentive between those who pay for energy efficiency measures and those who benefit from them (Pelenur & Cruickshank 2012; Elsharkawy & Rutherford 2015; Stafford et al. 2011).

#### *2.4.4.3 Disruption of installation of energy efficiency measures*

The most common non-financial barrier is identified as the 'hassle factor' or the disruption which energy efficiency retrofit causes (Dowson et al. 2012; Gilchrist & Craig 2014; Mallaburn & Eyre 2014). This includes having to clear the loft before having a loft insulated, physical disruption during the retrofit event, or the need to redecorate afterwards.

#### **2.4.4.4 *Engagement in installation of energy efficiency measures***

For some, a barrier to undertaking energy efficiency work is a lack of trust for the delivery bodies involved (most recently national government and energy supply companies in the UK) (Mallaburn & Eyre 2014; Pelenur & Cruickshank 2012). Even for those who wish to undertake energy efficiency retrofit, a key barrier can be the difficulty of finding a professional with the appropriate knowledge for installing more technical energy efficiency technologies, and this is further exacerbated by the conflicting pressures on sole traders in the building profession not to innovate and offer new technologies (Owen et al. 2014).

#### **2.4.4.5 *Engagement in use of energy efficiency measures***

A barrier to individuals' ability to adopt and use technologies is a lack of understanding by the householders of how technologies work or having insufficient expertise to operate technologies in their desired way for optimum performance (Gilchrist & Craig 2014; Behar & Chiu 2013). Issues of heating control usability were identified as vision (displays hard to read), positioning (controls not in an accessible place), dexterity (small buttons or stiff radiator valves) and thinking (complex interfaces and technical manuals) (Gilchrist & Craig 2014; Consumer Focus 2012; Rubens & Knowles 2013; Huebner, Cooper, et al. 2013; Munton et al. 2014).

### **2.4.5 The energy performance gap**

Even when energy efficiency technologies and measures are adopted by households, the expected energy savings are not always achieved; this is referred to as the 'Performance Gap'. The performance gap has been the focus of much research in the past few years (Oszt 2014; Johnston et al. 2014; Gupta et al. 2015; Zero Carbon Hub 2010; Blight & Coley 2013) and addressing it is imperative for the realisation of the much needed energy consumption savings in the building sector. The scale of the performance gap can be as high as 100 % or more (Stafford et al. 2011; Zero Carbon Hub 2010; Johnston et al. 2014) and causes may be technical or may be a result of the influence of occupants on energy consumption (Stafford et al. 2011). Technical causes of the performance gap may occur at the design stage or at the construction stage, requiring that modelling and calculations of energy savings due to retrofit reflect the actual performance of technologies in the real world (de Wilde 2014) and that the specified design is actually built. As an example, empirical studies have shown that the thermal transmittance of an uninsulated solid wall is lower than the standard calculated value used in assessments, and that the average value post insulation is not as low as stipulated in building regulations; this discrepancy leads to energy savings being lower in reality than in design calculations (Stevens & Bradford 2013; Baker 2011; Rye & Scott 2012; Li et al. 2015). The shortfall in insulation performance has

been attributed to difficulties faced by installers such as aesthetic and economic impacts of extending roof rafters and eaves to accommodate thicker insulation on the outside, or householders not willing to accept a loss of space on the inside (Stevens & Bradford 2013).

The occupant contribution to the performance gap is likely to be the cause of the significant differences between predicted and achieved energy savings. It is typical for those responsible for retrofit work such as industry professionals or policy makers to blame householders for the performance gap with a view that the gap could be closed by disseminating information to improve householder knowledge about 'correct' energy practices and ways to interact with the technologies (Brown & Swan 2012). Ellsworth-Krebs et al (2015) attributed the performance gap to a tendency for designers to focus on making a 'house' more energy efficient whilst overlooking the complexities of people and their household practices. Brown and Swan (2012) blamed technology designers for making key retrofit technologies unintuitive and difficult for householders to adopt. A key cause of the performance gap, however is attributed to rebound effects (see Box 2-2) including take-back or comfort taking. Comfort taking is the phenomenon by which a part of the benefit of energy efficiency measures is taken through increased warmth rather than solely as energy savings, and is typically identified as a higher internal temperature within the dwelling following retrofit work (Love 2012; Wyatt 2013; Guertler 2012). The physical part of this 'temperature takeback' (the increased internal temperature due to the improved energy efficiency of the building fabric) was investigated by Deurinck et al (2012), who found an increase of about 1 °C independent of a change in households' heating behaviour, and thus demonstrating that the occupant-driven share of take-back may be smaller than initially assumed.

*Box 2-2 The rebound effect*

The concept of Jevons' Paradox, or the rebound effect, is an economic explanation for why the benefits of energy efficiency can be compromised by increasing demand. Jevons' Paradox states that if more efficient use of energy results in reduction of energy demand, the price of energy would reduce due to market forces and this would encourage greater energy use rather than savings, exemplified in the coal industry of the mid nineteenth century (Jevons 1865; Alcott 2005; Sorrell 2009). The rebound effect is an umbrella term for various mechanisms which lead to a reduction in the energy savings realised by energy efficiency measures compared to the expected savings, such as the reduced cost per mile of a more efficient car, meaning that more miles can be travelled for the same price (direct rebound), or reduced heating costs for a house relieving more disposable income allowing for an alternative energy intensive activity to be undertaken (such as flying on holiday) (indirect rebound) (Sorrell 2009; Sorrell 2010; Alcott 2005). Solutions to these problems may be physical caps such as quotas or rationing (Alcott 2005) or the pursuit of improved efficiency being 'complemented by an ethic of sufficiency' (Sorrell 2010).

## 2.5. Building modelling

This final section of the literature review focusses on building modelling, beginning with types of building models and then reviewing previous approaches to including energy services and occupancy within building models. A model is a way of linking inputs to outputs through some type of simulation engine and building energy models (BEMs) allow the calculation of energy demand in a building based on known, assumed and approximated values of building characteristics, weather data and occupancy. Motivations for building modelling are the classification of energy performance or environmental impact of new and existing buildings, evaluation of alternative designs, prediction of building energy consumption, detection and diagnosis of varied or unusual energy consumption or economic optimisation (Wang et al. 2012; Al-Homoud 2001).

### 2.5.1 Types of models

#### 2.5.1.1 *Black, white and grey boxes*

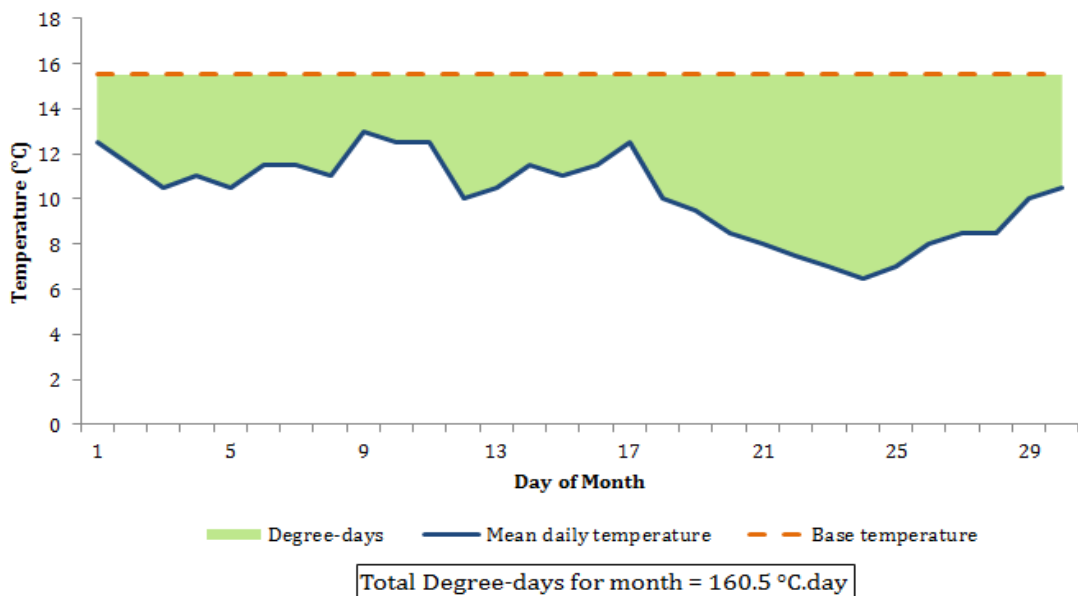
Two contrasting approaches to building modelling are the use of either physical equations (both theoretical and empirical) or statistical correlations; Fouquier et al. (2013) described these as white box methods and black box methods respectively.

Statistical methods (black box models) do not require physical information about a building, but use historical energy usage statistics in regression models to correlate energy consumption data with influencing variables. These regression models can be used to predict energy usages (or to compare energy usage over two different periods) taking account of simplified variables such as one or several weather parameters. Examples of this method are degree day analysis (see Box 2-3), multiple linear regression analysis or conditional demand analysis. Alternatively, statistical methods can be used to predict useful energy indices, such as the thermal behaviour of the building, or to model heating or cooling loads according to a climatic index. Thirdly, statistical methods can be used to estimate important parameters of energy usage. These parameters can be used directly to forecast future energy use or the parameters can be taken as inputs to physical models, thus making them hybrid models (Zhao & Magoulès 2012). Neural networks, Genetic algorithm, and Support Vector Machine are examples of statistical machine learning type models. In general, the models vary according to their ability to work with limitations of the data available, where generally problems of limited data are handled by greater complexity of the statistical model (Fouquier et al. 2013).

**Box 2-3 Degree-day analysis**

Energy demand for heating is dependent on the difference between the outside temperature and the desired internal temperature, related to both the transmission losses through the building fabric, and the heat required to bring incoming air up to the desired temperature. The measured temperature difference can be used in instantaneous calculation, but for calculating heat demand over longer periods, the theory of degree-days has been developed. Degree-days are also used for normalisation of data for heating or cooling energy use such that heating or cooling systems can be compared on an equal basis.

Degree-days are the summation of temperature difference over a period. Heating degree days give information about heating demand and are a measure of temperature below a desired base temperature and conversely, cooling degree days give information about cooling energy demand and are a measure of temperature above a base temperature. The base temperature is a balance point temperature, above which the heating (or below which for cooling) systems do not need to run in order to maintain a thermally comfortable internal condition. Base temperature is not equal to desired internal temperature, due to contributing effects of internal gains (CIBSE 2006b). Figure 2-2 illustrates the calculation of degree days in the case of heating degree days. The number of degree-days is equal to the area between the graph of daily mean temperature and the base temperature.



**Figure 2-2** Illustration of heating degree-days calculation

‘White box’ models have greater transparency in how input variables affect the output results; this field of calculation based models is broad and covered extensively in the literature. Heat demand calculations are based on thermodynamic equations for heat flows into and out of a building, which may be treated as a single or multiple zones. Equations are evaluated over a given time-step; the time step may be short (1 second to 1 hour) or long (a month or a year). Temperatures are averaged over the time step and therefore a shorter time-step allows a model to more realistically represent the dynamic reality of a house. The longer the time step, the better the model represents a steady state calculation.



The inputs required for energy modelling are typically *building* information (building construction, geometrical data, heat transfer characteristics of the building envelope, thermal radiation transmittance of windows, utility rate schedule, heating, ventilation and air-conditioning (HVAC) equipment) and *environmental* information (Temperature, relative humidity of outdoor air, wind speeds, solar radiation intensity) (Ayres 1995; Wang et al. 2012; Zhao & Magoulès 2012). Inclusion of *building usage* factors are also becoming more common (such as occupancy scenarios and internal thermal comfort target levels) (Foucquier et al. 2013). When fed into a model, these inputs are split into fixed parameters for each comparative case and design variables. The fixed parameters should include environmental conditions, building geometry and building construction (in the case of a retrofit of an existing building). The design variables such as heat transfer characteristics, window designs, HVAC equipment and thermal comfort specification can then be modelled for different scenarios in order to evaluate the most effective design combinations. The output of a model is energy performance information such as periodic (monthly, annual) energy usage or CO<sub>2</sub> emission, or could be more detailed such as electric power demand (or other fuel), for each end-use, system component or thermal zone (Wang et al. 2012; Foucquier et al. 2013).

There exist a continuum of models between the purely calculation based and purely data based which use aspects of statistical data within a framework of calculations and have been termed 'Grey models' or hybrid methods (Foucquier et al. 2013). In most cases, hybrid models use statistical methods for parameter identification to be used within the physical models. With a variety of tools to work with, the potential for hybrid solutions is vast, being particularly useful in situations where neither physical data nor historic data is sufficiently complete for use of solely physical or statistical models (Foucquier et al. 2013; Zhao & Magoulès 2012; Wang et al. 2012).

### 2.5.1.2 *Heat balance model complexity*

The complexity of BEM calculation methods can vary depending on the time and spatial resolution with which a building is modelled. The most simplified method for energy calculations are steady-state models in which energy consumption is calculated for a period of a month or a year in one step with input values averaged over this period. Total heating degree days can be used as an aggregate of the difference between internal and external temperature over a modelled period, which is required for heat loss calculation. Conversely, dynamic models take time variation into consideration and are thus able to achieve a higher level of time resolution from a day to a second. With regards to spatial resolution, buildings may be represented at one extreme as a single zone, and at the other extreme as many individual control volumes. Thermal heat balance equations are

calculated for each model zone. The most complex approach is through CFD (Computational Fluid Dynamics) in which three-dimensional fluid dynamic equations are solved to produce a detailed representation of flows inside a building over a large number of small control volumes. CFD models require high computational power and take far longer for models to run and therefore the high complexity is usually beyond the scope of domestic building modelling. Fouquier et al. (2013) recommended a zonal approach for applications concerning indoor thermal comfort.

An example of a steady state model is Building Research Establishment's Domestic Energy Model (BREDEM) which is the basis for the Standard Assessment Procedure (SAP) and the calculation for Energy Performance Certificates (EPCs). It is a steady state model as it calculates energy demand over monthly time-steps. The model comprises two thermal zones, allowing living spaces and rest of house to be treated differently. Temperature values for internal and external temperatures are taken as monthly averages with the time profile of the heating requirement being taken into account. Default value assumptions built into a model allows estimates of energy usage to be calculated if not all input data is available (but ability to input known details allows more rigorous calculation) (Anderson et al. 1985). The large influence that building occupancy has over energy consumption was recognised in the development of the Green Deal assessment (also based on SAP). Calculations of energy savings for a range of energy efficiency measures included information from an occupancy assessment. The occupancy assessment incorporated details on occupancy schedule, set-point temperatures, specification of secondary and alternative heating types, as well as appliance usage. The main advantage of a simplified single zone, steady-state model is that it is straight-forward to run and the model requires minimal computational time. These models also have the potential to be scaled up for the purpose of macro modelling of a city, region or country; the Cambridge Housing Model (Hughes 2011) is an example of such an application whereby the effects of energy efficiency measures can be modelled for the whole UK housing stock (Hughes et al. 2013; Palmer et al. 2012).

Building models with greater complexity include a wide range of commercial software which run multi-zone dynamic models (such as EnergyPlus, TRNSYS, IES or ESP-r). These models allow a broad range of inputs and outputs and use more complex physical thermodynamic equations for calculation. As well as heat loads, simulations can model aspects such as on-site renewable energy generation, electricity loads from lighting and appliance usage, indoor air quality and thermal comfort (as PMV or PDD). The user interface of these models varies from text files to more user friendly programmes (Crawley et al. 2008).

### 2.5.2 Inclusion of energy service and people within building models

In recognition of the effect that occupancy behaviour has on real world energy use, the inclusion of more realistic occupancy profiles has been a focus of building modelling literature in recent years. As an approach to including realistic occupancy patterns, model inputs can be either stochastic, deterministic, or a hybrid of the two. Stochastic model inputs involving statistical pattern generators, as discussed in section 2.3.3.2, have been used as a tool for simulating random daily occupancy for model input (Richardson et al. 2008; Richardson 2010; Widén et al. 2009; Widén & Wäckelgård 2010; McKenna et al. 2015). Deterministic models use occupancy archetypes (as presented in Table 2-4) to define different types of households (Yao & Steemers 2005; de Meester et al. 2013; Motuziene & Vilutiene 2013; Aerts et al. 2014). Other studies have measured occupancy usage and behaviour directly and inputted these into building models to compare the modelled and measured data (Rijal et al. 2007; Eguaras-Martínez et al. 2014; Ingle et al. 2014).

Examples of the inclusion of aspects of energy service approach in building modelling are found in literature, and these studies specifically determine energy demand end uses according to the service being provided. Pedrasa et al. (2011) propose an energy service modelling technique in which energy service demands are temporally matched to distributed energy resources in the context of a smart home. Their model takes into account that the demand for energy services changes with time (for example, in a restaurant hot water is only in demand at certain times in the day), and therefore the value of the service is also perceived to change. Service is assigned a fixed value of “energy equivalent” independent of the amount of electrical (or other) energy consumed to provide it; the value of the ‘hot water energy service’ would be assigned to the thermal energy content of the water required, rather than the energy consumption of the heater. The end-user is able to specify the importance of the service throughout the day, and the model thus takes into account the flexibility of the service, allowing for flexibility of the way in which the service is delivered. Rysanek and Choudhary (2012) developed a building model which determined the optimal building retrofit options to satisfy the service demands of the users. Their definitions of services came from stochastically predicting the occupancy and thus the demand load on appliances. They describe the process as 'analogous to a reverse Sankey diagram', starting with occupant's needs and ending with the amount of primary energy needed to deliver them. Their ‘Sub-model 1’ was the occupant service demand model, which involved the estimation of service demand through the probabilistic modelling of occupant-driven demand. This involves ascribing the probability of occupancy and use based on the time of day, day of the week, month of the year and the

variable's state (appliance/lighting/heating in use or not) in the previous hourly time step. The user must specify the probability of an object's state of operation based on these parameters, and this is used in stochastic demand load modelling to predict set point temperature, heat gains and electrical load in the building for hourly time steps. These are fed into a dynamic building energy model ('Sub-model 2'), which calculates the heating, cooling, hot water (thermal) and electrical demand for a range of inputted technologies, and an energy supply system model ('Sub-model 3') calculating primary energy consumption and resulting greenhouse gas emissions for the technology combination identified to suffice the service demand. The results from case studies for a primary school and office found that the greatest greenhouse-gas emissions were achieved by combining as many demand side measures as possible (which they concede 'could have been assumed without requiring an exhaustive engineering simulation of options'). However, the model proved more useful by imposing a particular energy or emissions reduction target, return on investment target or capital cost constraint within which boundaries optimisation of technology combinations could be performed. By combining these engineering and economic aspects of modelling, they produced a tool for computing the primary energy consumption of different options.

The term thermal comfort is widely used in building energy modelling software to describe the desired temperature, humidity and air flow rates within a building. Existing models refer to thermal comfort in passing or directly as a design constraint or optimisation variable (Crawley et al. 2008; Magnier & Haghghat 2010; Szokolay 2007; Gupta 1970). Gupta (1970) modelled building energy consumption using an optimality criterion of degree of discomfort based on thermal comfort requirements of preferred daytime temperature, daytime variability permitted, upper limit for night time discomfort and night time variability permitted. Peeters et al. (2009) conducted a study to modify the conventional criteria for thermal comfort in residential buildings. They intended the work for integration into building energy simulation programmes as an improvement upon conventional theories which were based on steady-state laboratory testing.

Two examples have been found in literature in which authors make attempts to incorporate aspects of social practice theory into energy modelling in order to build more representative models. Higginson et al (2011; 2014) used dynamic system modelling to represent the practice of "doing laundry" as an example of how SPT can be incorporated into a bottom-up practice based model of energy demand. Systems dynamic theory allows the portrayal of complex systems into a few simple components characterised as stocks, flows and feedback loops. Their work demonstrates that the practice of "doing laundry" can be mapped as a complex system within the broader life of a household, and that by considering 'stuff', 'image' and 'skill', the boundary of the system is wider than just the

washing machine. This enables the identification of a broader space for analysis when looking for possible interventions in reducing energy demand for laundry. Rodriguez and Calderon (2014) outlined how the insight gained into household heating practices within SPT could be applied to a city scale model for calculating energy demand in the household sector. In their approach, they consider household practices as the base level of energy use and therefore the predicted energy use of the city is based on variety and flexibility rather than typical or average behaviour. They propose the carrying out of a survey to develop a better understanding of how household practices and demand-side flexibility affect energy demand. The outcome of this work would be to model energy demand at residential level and to be able to evaluate how different practice scenarios would affect total energy demand. These previous studies demonstrate that there is interest in incorporating household practices into models of household energy demand in order to improve tools for investigating how to reduce energy demand.

## 2.6. Conclusion

This literature review has covered a broad range of topics as related to considering building retrofit using an energy services approach. Key themes have been identified and these expose gaps in the literature which inform the research of this thesis. The major research areas which will be brought together within this thesis are as follows:

Within the area of energy services concept, three themes have been identified. The energy chain from well to welfare includes energy service delivery as the pivotal step between the upstream energy supply system and the consideration of lifestyle and human behaviour in determining energy demand. Energy service delivery is central to the concept of a performance based energy economy and as applied within the domestic sector this forms the basis of a domestic energy service company business model. Finally, the concept of sufficiency identifies stemming the increasing levels of energy service demand as the key requirement in ensuring that energy efficiency improvements lead to energy conservation. It also uses the consideration of equity in energy service delivery to distinguish between different levels of energy service which should be considered as basic needs or excessive consumption.

Leading on from energy service delivery, the role of household occupants has been reviewed with a focus on the variety of energy using behaviour. The fact that energy consumption is more greatly influenced by behaviour than by building characteristics

demonstrates the importance of including occupancy factors within building energy modelling and energy saving calculations. A large amount of work has been undertaken in gathering information on occupants, and a broad range of approaches have been used in previous studies to gain insight into household energy behaviours. These previous studies have resulted in an array of published data which is available to be used to inform modelling inputs within the present work. The review of approaches to gathering data has confirmed that the collection of additional primary data is a non-trivial procedure, and whether qualitative or quantitative, cannot be guaranteed to give a true reflection of the full breadth of reality. The data sources identified within this literature review are therefore deemed to be sufficient for the present work and primary data collection will not be undertaken.

The section of this review based on domestic retrofit has focused upon energy efficiency technologies, domestic energy efficiency policies, barriers to retrofit and the energy performance gap. The wide variety of energy efficiency technologies considered within literature as presented in Table 2-6 have been separated according to the energy service which they deliver, but this analysis can be developed in order to identify the way in which the technologies contribute to the service. The work by Cullen and Allwood (2010a), in which energy service delivery is considered to be achieved by both a conversion device and a passive system, introduces the concept that different technologies contribute to energy service delivery in different ways. Domestic energy efficiency policies have in recent years focussed mainly on removing financial barriers to retrofit uptake, but finance has been identified as only one of many barriers to the uptake of energy efficiency retrofit. The obstruction caused by each barrier will vary according to a household's situation and competency; therefore consideration of all barriers will be included within this work.

The final section of this literature review was a focus on building modelling in which types of modelling were compared. Statistical 'black box' models were compared to calculation based 'white box' models, and steady state heat balance models were compared to dynamic models. Building modelling is to be used as a tool within this work to gain understanding of how energy efficiency technologies can deliver energy service and therefore the transparency afforded by calculation based models is most suitable. The variation of energy service throughout the day dictates that a short time step is required and therefore a dynamic building model is more suitable than a steady state model. Previous studies have been reviewed in which energy services have been considered within building modelling. The energy service perspective used in these examples has been the definition of energy end uses as the service being demanded. Such work can be developed upon in the present study in order to use dynamic building energy model software to compare different types of

technologies in terms of how they deliver energy service and energy savings for retrofit of existing houses.

The literature review presented in this chapter has highlighted a number of gaps which enable a novel contribution to be made by the current work of this thesis:

- In a number of papers, the energy system has been considered as being made up of a full energy chain from primary energy to final delivered energy, to energy service delivery and in some cases, the satisfaction of welfare. Some studies have considered the role of technologies at certain stages within the chain, but there is no evidence that technology analysis has been carried out through from primary energy to welfare. In particular, the final step of the chain from energy service to welfare has not been present in such analyses.
- In the discussion of a performance based energy economy and the business model of a domestic energy service company, there has been little consideration for how to measure the service delivery and energy savings attainable for different energy efficiency technologies and measures. Such a tool would enable the development of the DESCo business model concept.
- The differentiation of conversion devices and passive systems has highlighted the different ways of contributing to energy service delivery and energy savings. However, not all types of energy saving technologies and measures as identified in Table 2-6 can fit into these two distinctions. There is therefore opportunity to broaden this classification such that additional approaches can be included in which technologies contribute to an energy service delivery in a different way.

The following chapter begins by addressing how these novel aspects identified will be developed within the research methodology, and will go on to outline the analytic framework which underpins this thesis.





# Chapter 3 Research Framework

The literature review has introduced conceptual areas where contributions can be made to the understanding of the reduction of energy use in buildings; energy efficiency technologies and technology assessment, building modelling and energy service delivery. Research gaps were identified, and these inform the methodological development of this thesis in section 3.1. Subsequently, the analytic framework of the thesis is presented in section 3.2 in which the links between each conceptual area are further explored. The application of the analytic framework in the following three chapters will be fully described.

## 3.1. Methodology development

In order to respond to the gaps in the literature identified in section 2.6, aspects of methodology which will apply throughout this thesis are now explained. These are the explanation for focussing on a single energy service, the methods for applying the energy service concept according to the energy chain, and the approaches to data collection and building modelling within the thesis.

### 3.1.1 Narrowing focus of thesis to a case study of heating thermal comfort

The review of energy service literature in section 2.2 focussed on domestic energy service in general due to the reduction of domestic energy consumption being a motivation for this thesis. In order to explore the ideas within this thesis for comparing the delivery of energy service and energy savings by different types of energy efficiency technologies and measures in more depth, a single energy service will be made a focus of the analysis in the following three chapters. Analysis of heating thermal comfort has been chosen as a case study for the energy service approach, and will henceforth be termed 'HTC'. In the UK,

heating accounts for 60 % of domestic energy consumption (Palmer & Cooper 2013) and therefore is a priority for energy reduction. HTC is expected to provide a clear and interesting demonstration of the methodology used in the following three chapters. The application of this methodology to other energy services with different end user applications will then be expanded in the Discussion Chapter (Chapter 7).

In order to further define what is meant by HTC, the service dimensions presented by Jonsson (2011; 2005) are used as a service description framework and the aspects are described in Table 3-1.

*Table 3-1 Definition of heating thermal comfort energy service using service dimension framework presented by Jonsson (2011; 2005)*

<b>Service dimension</b>	<b>Description for heating thermal comfort energy service</b>
<b>Volume</b>	Quantifiable amount of energy service delivered will be such that different energy efficiency technologies and measures can be compared on its delivery. Previous examples for thermal comfort have been m <sup>2</sup> of heated floor area, m <sup>3</sup> K of heated air and temperature (or change in temperature) (see Table 4-1). It is important that the metric used prioritises energy conservation over energy efficiency and therefore the aim is to identify a metric as close to the true demanded service as possible.
<b>Content</b>	The delivered service within this work is a warm occupied space. The temperature which is considered warm is known to be variable for different occupants and this will be taken into account. The occupied space will be considered based on typical patterns of household occupancy.
<b>Quality</b>	The way in which HTC will affect how it is experienced by the household. This will include consideration of suitability of energy efficiency technologies and measures to households so that meaningful recommendations are made for energy efficiency work. Barriers and drivers to adoption of each measure will also be considered, such as whether they are reliable, responsive, attainable at a low capital cost, and whether the occupants can use the technologies properly.
<b>Motivation</b>	The service is demanded due to practical and aesthetical reasons. Practical reasons are the preservation of health which can be compromised by a home which is too cold. As well as health concerns, carrying out day-to-day activities can be made difficult if the home is too cold. Aesthetical reasons are taken to represent the desire to have a warm home and the choice of temperature may be a personal preference for a certain internal ambience. The motivation for HTC may also be symbolic, if households perceive that a certain internal temperature is required when entertaining guests (social pressures), but this will not be considered explicitly within this work.

### 3.1.2 Application of energy service concept

Through the literature review in section 2.2, insight has been gained towards developing a methodology for applying the energy service concept to the present work. Of the three themes identified within the energy service concept, it is the first theme which considers the full energy chain from well to welfare which is most applicable to this project and has implications at each stage of the chain.

At the beginning of the chain, from primary energy to the point at which final energy is used in the home, it is identified that comparisons should be made for primary energy or primary resulting CO<sub>2</sub> emissions rather than final energy only. It is also identified that embodied energy of technologies should be taken into consideration. At the step from final energy to energy service, the methodology will be to consider different approaches to low carbon energy service delivery, with technologies and measures classified appropriately. Further downstream at the stage from energy service to welfare, the ability of technologies and measures to be adopted by householders and used to their predicted ability will be based on consideration of household attributes. The first of these three stages will be further explained in Chapter 4, but the latter two stages will be further expanded below.

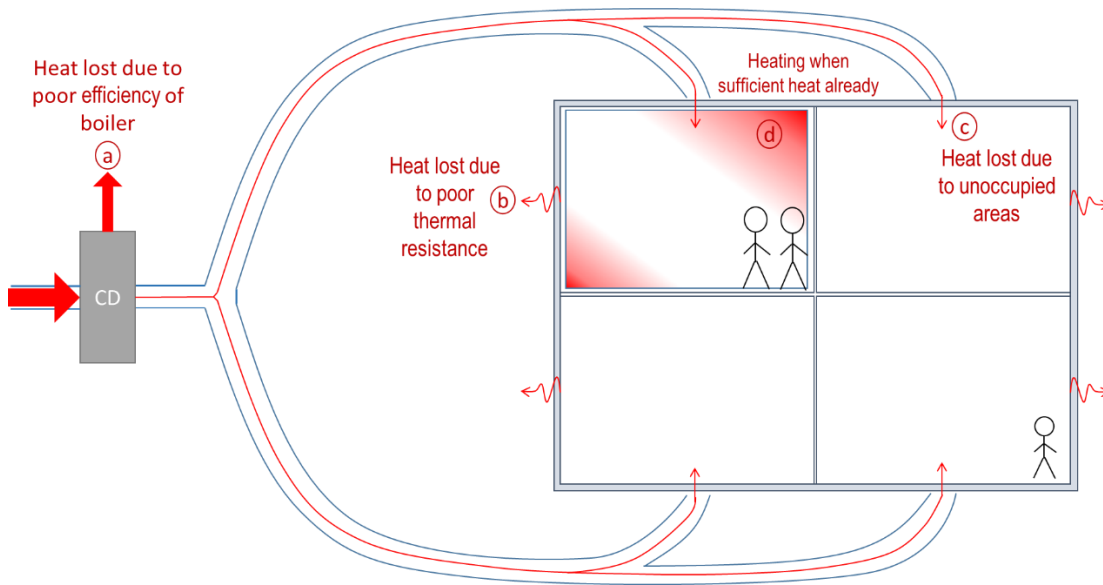
#### *3.1.2.1 Final energy to energy service: classification of energy efficiency technologies for heating thermal comfort*

Thermal comfort is delivered through the management of heat within an occupied space. Technologies can improve the efficiency with which heat is managed and therefore can enable thermal comfort to be delivered with a lower energy input and lower environmental impact.

Improved efficiency of heat management for thermal comfort within a building can be considered in four ways as illustrated in Figure 3-1:

- a) **More efficient heat input:** The efficiency of the transformation of final energy to useful heat energy is increased so that more heat is inputted to the house per unit final energy. This is achieved with a high efficiency **conversion device** (as described by Cullen and Allwood (2010a));
- b) **Keeping heat in for longer:** The thermal resistance of the building envelope is improved so that more heat is retained to deliver the service of thermal comfort for longer. This is achieved with an improved **passive system** (as described by Cullen and Allwood (2010a));
- c) **Directing heat to the right place:** Thermal comfort is only delivered in an occupied room and therefore the heat is directed to occupied spaces within the house. Adoption and correct usage of **heating controls** can ensure that heating is only on at the right time and in the right place;
- d) **Putting in right amount of heat:** The heat input is correctly matched to the heat demand so that the level of thermal comfort delivered is not higher than required. This is achieved using heating controls and a consideration of the service level

required. To avoid wasted heating, the service delivered can be adjusted to exactly match the service demanded in both time, space and temperature.



*Figure 3-1 Illustration of heat management approaches*

The conversion device and passive system classification introduced by Cullen and Allwood (Cullen & Allwood 2010a) form the basis for heat management by approaches (a) and (b) as defined in section 2.2.1. Improvement of the efficiency of these technologies will lead to better heat management and lower heat loss. Approach (c) and (d) establish the need for control technologies such that heat is directed to the right place at the right time in the right level (required temperature) in order to deliver a comfortable temperature in an occupied space. The definition of what temperature is necessary to feel comfort and which spaces are required to be heated are the basis of a description of a service level, and changing of these specifications for the service level can be considered as an energy efficiency measure in its own right. Therefore, the four approaches to heat management illustrated in Figure 3-1 are translated to the technologies and measures which are required and these are categorised within this thesis as improvement to the conversion device, passive system, service control and change in service level. Of the 138 technologies which were identified in Table 2-6 of Chapter 2, 28 which relate to HTC have been classified in Table 3-2 into their appropriate energy service delivery categorisation.

*Table 3-2 Technologies for delivering thermal comfort derived from literature review*

<b>Contribution to Thermal Comfort Delivery</b>	<b>Technology options</b>
<b>Conversion Device</b>	Storage heaters (using grid electricity at low demand times) Micro CHP Biomass boiler Boiler with high efficiency using mains gas Air / Ground source heat pump Phase change material Heat gain windows District heating Under floor heating Mechanical ventilation with heat recovery (MVHR)
<b>Passive System</b>	Insulation of walls, ceiling, floors Double / triple glazing Insulated door Draught proofing Draught lobby Insulated hot water cylinder and pipes Minimisation of thermal bridging Phase change materials Thermal mass of room and building envelope
<b>Service Control and distribution</b>	Radiator valves Thermostatic radiator valves Programmable heating control Heating time-switch Advanced heating control (zonal control, remote access) Ceiling fans
<b>Service level</b>	Reduced Internal temperature (set by thermostat) Delayed start of heating season Reducing heated floor area (Heating turned off in unused rooms)

A subset of each technology approach will be used in the following three chapters in order to compare the energy service delivery with a lower energy input of different types of energy efficiency technologies and measures.

The classifications of technologies as described above allows for the inclusion of aspects of sufficiency as reviewed in section 2.2.3. Brischke et al.'s (2015) three interventions of substitution, reduction and adjustment are represented. The ability of substitution to enable energy demand reduction is demonstrated by the comparison of the different technologies to deliver the same service. Adjustment is represented within the service control and distribution technology classification such that the service delivered can be best matched to the service which is demanded. Reduction is represented within the service level classification such that a lower level of service demand can be compared to other technology options within the analysis.

### *3.1.2.2 Energy service to welfare: classification of household attributes*

A third novel aspect of this thesis is in linking the energy service delivery to the satisfaction of welfare. As has been illustrated through the review of household occupant's energy use in section 0, there exists a wide variation in what people expect from their home heating systems and how they can and will interact with the system in order to attain thermal comfort for themselves. The approach for use in this thesis is inspired by aspects of social practice theory and consideration of barriers to adoption, and is informed by the review of household archetypes in section 2.3.4.

Within social practice theory, elements of practice have been identified in literature as 'meaning', 'materials', 'skill/know-how' and 'rules' (Shove & Pantzar 2005; Gram-Hanssen 2011). Of these, 'materials' is typically the only element to be included within consideration of energy efficiency retrofit, with energy savings attributed solely to technology uptake. 'Rules' may also apply, if new technologies are legislated or psychological approaches to technology take-up (such as social pressures) are included. Through an analysis of the household archetypes identified from literature in section 2.3.4, 'meaning' and 'skill/know-how' emerge as the two main themes by which household occupants are categorised. Using these two elements as dimensions for classification of people, the suitability of EEMs to specific households can be assessed based on the likelihood that household practices would adapt to the adoption of each EEM. Classification of households will thus be made by the following two aspects:

- Motivation for energy efficiency action. For the purpose of the present study these disparate motivations will be classified as:
  - **Comfort:** motivated by the house being sufficiently warm and comfortable;
  - **Cost:** motivated by reducing the cost of energy use within the house; and
  - **Climate:** motivated by a desire to protect the environment from harmful impacts of energy use.
- Skill or know-how of occupants as related to use of technical devices (such as heating controls), DIY measures and navigation of the process to install larger measures. For the purpose of the present study, these competencies will be renamed as:
  - **Technical skill:** Householders have the skills to use technical equipment with confidence.
  - **Professional co-ordination:** Householders have the know-how to arrange professionals to do installation work for them.

- **Limited technical capabilities:** Householders lack the technical skill or know-how to use technical equipment or arrange professional work to be carried out.

These elements can inform the types of people which will adopt certain EEMs and more importantly use them to their fully efficient potential. The first categorisation of motivation for energy efficiency action will be evaluated through the modelling work within the following three chapters, in which technologies will be assessed for energy saving potential and how well they compare in delivering the demanded level of service. In contrast, technologies can be attributed to the second characterisation through understanding of relevant barriers, review of empirical studies and knowledge of the technologies. Large technologies such as insulation and boilers are typically installed by professionals, whilst advanced heating controls require a medium to high level of technical skill.

#### 3.1.3 Data collection

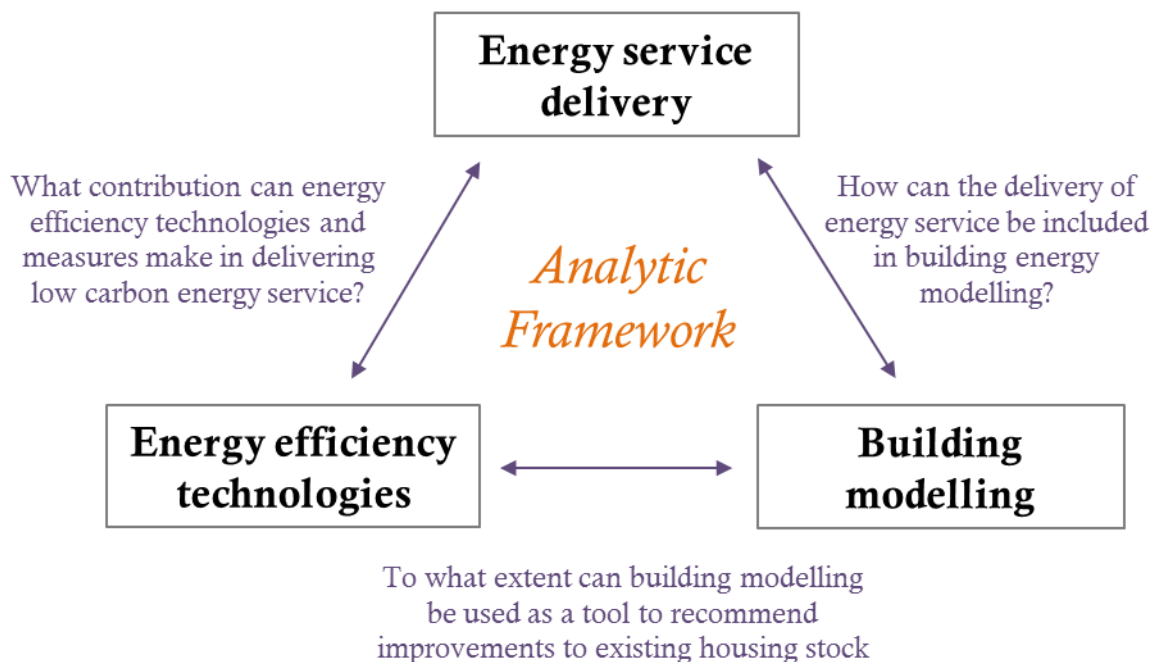
In order to represent a real world home within a building model, and to understand drivers and barriers to adoption of technologies, data is required for this thesis. The decision not to undertake primary data collection is made due to the broad range of data types required in an interdisciplinary study such as this. Such data can be classed as building model parameters, occupancy information and model validation data. Instead of focussing time on primary data collection, suitable data has been taken from literature which satisfies the purpose of this work and recommendations are made for what further data collection could be undertaken to strengthen the findings. The methodologies of analysis are explained in detail within each chapter.

#### 3.1.4 Building modelling

Building modelling has been identified within the analytic framework, and three different approaches will be used through the following three chapters. In Chapter 4, a simplified building model will be developed within Microsoft Excel using thermodynamic energy equations. This will allow for the technologies to be investigated from first principles. In chapter 5 and 6, a dynamic simulation software, TRNSYS, will be used in order to develop a more sophisticated model of a house. TRNSYS uses a similar modelling approach to other simulation packages, but the modular design allows for greater flexibility for describing novel systems. In chapter 5, the multi-zone building unit will be used in its primary functionality to calculate heat loads in a typical heat balance format. In Chapter 6, the modular form of TRNSYS will be used to greater effect in order to better replicate a typical house heating system.

## 3.2. Analytic framework

This thesis recognises the value in exploring the interplay between the three conceptual areas of energy efficiency technologies and technology assessment, building modelling and energy service delivery. By highlighting and exploring the connections between the three established energy efficiency related topics, their applications can be broadened, and extended into areas previously un-considered. The integrative approach developed in this dissertation is the analytic framework as presented in Figure 3-2.



**Figure 3-2** Thesis analytic framework diagram showing interlinking aspects of energy service delivery, energy efficiency technologies and building modelling

The present section explains how the three identified linkages underlie the following three analysis and results chapters. The first of these chapters (Chapter 4) is a substantive comparison of metrics used for measuring the low carbon delivery of heating thermal comfort (HTC) and specific units of service delivery. Simple modelling using a quasi-steady-state model in excel subsequently allows different technological approaches to be compared for each metric, and for the suitability of the metrics to be assessed. Chapter 5 applies the results of Chapter 4 within a more complex building energy model, TRNSYS. Energy efficiency measures are compared for three different occupancy patterns based on how well they deliver the demanded level of HTC with lower energy inputs. Chapter 6 is an investigation of how energy efficiency measures deliver the service of HTC and how this can be predicted using building energy modelling software.



### 3.2.1 Development of service unit concept (Chapter 4)

The focus of Chapter 4 is on service unit metrics for the comparison of different technology approaches to delivering low carbon heating thermal comfort. Metrics used in previous studies are identified and contribute to the identification of four metrics to be investigated. These four metrics are compared based on different approaches to heat management within the home using a simple quasi-steady-state model in Excel.

#### 3.2.1.1 *Technology and energy service link*

The first link between technologies and energy service theory is in identifying different ways of delivering a comfortably warm occupied space in terms of flow of heat. From these first principles, technologies are considered. Secondly, the full energy chain from well to welfare is incorporated by calculating the embodied energy in the technologies within the analysis. Calculations of embodied energy enable the full energy input per unit of service to be included in analysis.

#### 3.2.1.2 *Building modelling and technology link*

The integration of technologies and building modelling is established through the modelling of the four technology approaches to heat management. In this first results chapter, technologies are represented using simple heat balance equations within a quasi-steady-state Excel model based on key parameters which represent the technologies' contribution to energy savings. Based on the modelling, preliminary comparisons are made of how the different technology approaches deliver HTC with lower energy demand and carbon emissions.

#### 3.2.1.3 *Energy service and building modelling link*

This final link of the analytic framework is fundamental to the analysis of Chapter 4 which focusses on what unit of energy service is appropriate for comparing approaches to service demand and delivery within building models. Through the comparison of different metrics for the measurement of service, a basis is formed for the subsequent modelling of the energy service of HTC in the following chapter. The calculation of embodied energy and embodied carbon provides a potential basis for the upstream energy of technologies to be compared alongside the operational final energy of energy service delivery.

### 3.2.2 Modelling of energy efficiency measures and occupancy patterns (Chapter 5)

The focus of the Chapter 5 is on how different energy efficiency measures deliver energy savings for different household occupancy patterns. The occupancy patterns represent

different definitions of service requirement. The energy efficiency measures considered are four approaches to the delivery of lower carbon heating thermal comfort energy services. Modelling is undertaken using TRNSYS building energy modelling software, which is coupled to a Matlab script to enable comparison of different energy efficiency measures and combinations.

### ***3.2.2.1 Technology and energy service link***

The technology focus of this chapter is on the different ways of delivering the energy service of thermal comfort, developed on from Cullen and Allwood's distinction of conversion device and passive system to include control and service level. Consideration of the full energy chain from well to welfare is focussed on the link of energy service-lifestyle-welfare and the interaction of people with technologies. Barriers and drivers of adoption are matched to EEMs in order to identify factors affecting suitability for different types of people.

### ***3.2.2.2 Building modelling and technologies link***

The link between technologies and building modelling is based on the development of a building model in which technologies and measures are compared; the building model uses TRNSYS software and a Matlab script for selection of parameters for comparison as well as results analysis. For some EEMs, their inclusion is fundamental to the TRNSYS model whilst other EEMs require a more innovative approach for modelling. The building model allows different EEMs to be compared for different occupancy patterns based on the calculated energy demand and energy savings.

### ***3.2.2.3 Energy service and building modelling link***

Energy service demand is represented within the building model through the three varied occupancy patterns, each a different service unit as defined in Chapter 4. This link in the analytic framework is included through the combination of the above two links.

## **3.2.3 Measuring service delivery (Chapter 6)**

Chapter 6 identifies which are the most appropriate metrics for the measurement of heating thermal comfort service delivered by each combination of technologies and energy efficiency measures. In order to model this service delivery, it is necessary to develop the building model beyond the traditional heat balance approach to better represent an indoor temperature profile measured in a real house.

### ***3.2.3.1 Technology and energy service link***

For continuity, the same technologies and EEMs are included in the analysis of this chapter, as in Chapter 5. The four different energy efficiency approaches provide a broad view on the options for delivering the service of HTC defined as a desired comfort temperature at occupied times. The different levels of service delivery allow for further discussion of the suitability of EEMs to types of occupants and this forms the link between energy service, technologies and delivery of welfare.

### ***3.2.3.2 Building modelling and energy service link***

The building model is developed to allow for comparison of service level demanded and delivered; a more representative model is developed based on the functioning of a real radiator heating system and resulting in a more accurate temperature profile than the model in Chapter 5. Four approaches to measuring the service delivery within a model are compared, with consideration given to visual and numeric output. The consideration of suitability of EEMs to different types of occupants is discussed in terms of how this could be included in the model results.

### ***3.2.3.3 Building modelling and technologies link***

In this final results chapter, the building model is developed to more innovatively represent the delivery of HTC within a house (specifically a hard-to-treat solid wall dwelling). The results of the modelling provide a further dimension for the comparison of EEMs on multiple benefits of improved delivery of HTC and energy or CO<sub>2</sub> reduction.



# Chapter 4 Investigation of service unit of heating thermal comfort

## 4.1. Introduction

This is the first of three results chapters in which energy service theory, energy efficiency technologies and building modelling are brought together to explore a way to reduce energy consumption in hard-to-treat homes. The aim of this chapter is to develop metrics with which the modelled energy service delivery of heated thermal comfort can be compared for different energy efficiency technologies and measures (EEMs). Three potential metrics are identified through a literature review of previous approaches to measuring energy service efficiency, and are tested using a quasi-steady state model which is developed from heat balance equations using a Microsoft Excel spreadsheet. Four different technical approaches to heat management are compared, each of which contribute to reducing the energy input to delivering heating thermal comfort in different ways.

The chapter begins in section 4.2 with identification and description of three energy service efficiency metrics based on a literature review of existing metrics. Section 4.3 commences with a methodology for identification of technologies for comparison based on heat management and subsequently, four approaches for EEMs are introduced. The building model for use within this chapter is described in section 0. Section 4.5 is the main results section of this chapter, in which each energy service efficiency metrics is tested for each technology. The specific methodology for modelling is explained, followed by the generation and analysis of result, and this is applied in turn to the three energy service efficiency metrics of energy service energy intensity (ESEI) (section 4.5.1), energy efficiency defined as comparison to ideal demand (EEID) (section 4.5.2), and energy saving as compared to existing situation (ESES) (section 4.5.3). The results and findings of this chapter are discussed in section 4.6, and finally conclusions are drawn in section 4.7.

## 4.2. Identification of energy service efficiency metrics

The concept of energy service efficiency was introduced in the literature review (section 2.2.4) and now becomes the focus of this chapter. In particular, the objective is to determine which metrics are best for measuring the energy service efficiency of delivering thermal comfort to a house. A range of examples of service measurement from literature is given in Table 4-1.

*Table 4-1 Examples of units of thermal comfort related service in literature*

Service unit	Units	References
Heat provided to rooms <sup>1</sup>	J	(Sovacool 2011; Reister & Devine 1981)
Floor area of house	m <sup>2</sup>	(Bosseboeuf et al. 1997; Haas 1997; Phylipsen 2010; Sathaye 2010; Schipper et al. 2001)
Dwelling	Dwelling	(Bosseboeuf et al. 1997; Sathaye 2010)
Degree day (climatic correction)	dd	(Bosseboeuf et al. 1997; Haas 1997; Phylipsen 2010; Sathaye 2010)
Ideal demand	kWh	(Pérez-Lombard, Ortiz, Maestre, et al. 2012; Cullen & Allwood 2010b; Cullen et al. 2011)
Temperature (related to thermal comfort indices)	°C	(Carlucci & Pagliano 2012)
Heated floor area	m <sup>2</sup>	(Jonsson et al. 2011)
Total volume and temperature change	m <sup>3</sup> K	(Cullen & Allwood 2010a)

<sup>1</sup> Sovacool goes on to clarify that the units of work, or heat, or temperature, are surrogates for measures of satisfaction which human beings experience when consuming or experiencing energy services

In choosing a suitable metric, it is important that it encourages the achievement of the overall goal of this project; to reduce energy use and overall CO<sub>2</sub> emissions. Some metrics of efficiency can lead to greater overall energy consumption if they don't also focus on sufficiency of service demand. An example of this is using energy use per heated floor area, for which a larger house will have a higher efficiency but a larger energy consumption overall. It is also important to include whole system energy consumption and not just final energy, and therefore embodied energy and carbon in the technologies installed should also be integrated.

With inspiration from existing metrics and inclusion of the above considerations, three options have been identified for service metrics which are outlined below.

### 4.2.1 Energy service energy intensity (ESEI)

Energy service energy intensity (ESEI) is represented by the expression in (4-1); for the use of this expression, a service output must be defined.

$$ESEI = \frac{\text{Energy input}}{\text{service output}} \quad (4-1)$$

A possible approach for defining service output is to choose a micro unit with which service demand could be expressed; total energy required could thus be calculated by multiplying the energy service demand by the ESEI. Alternatively, the service output could be a defined service situation or level of service for a distinct house.

The concept of a service unit is adopted from the field of life cycle assessment (LCA). When performing the comparison of different products and services within an LCA calculation, the definition of a functional unit is crucial. Functional unit is defined by Cooper (2002) (with reference to the international standard ISO 14040:2002) as a measure of the performance of the functional outputs of a product system, including specification of the magnitude and duration of service and the product's life span. The purpose of the functional unit is to provide a reference to which the inventory data are related to ensure alternatives are compared on a common basis. Examples of functional units taken from LCA literature are presented in Table 4-2, and can provide guidance for choosing a functional unit for the present purpose.

*Table 4-2 Examples of functional units from LCA in literature*

Type of energy saving measure	Functional unit	Reference
<b>Light bulb</b>	Comparable lumen output, wattage, lifetime equivalent (when comparing to existing bulb)	(US Department of Energy 2012)
	Amount of visible light required + length of time light is provided	(Striebig et al. 2015)
<b>Insulation</b>	Mass of insulation to give a thermal resistance $R = 1 \text{ (m}^2\text{K)/W}$	(Ardente et al. 2008)
<b>Energy efficiency measures</b>	Energy saving over lifecycle of building	(Kneifel 2010)
<b>Comparing building aspects (such as heating system)</b>	Energy consumption over lifecycle Energy consumption per floor area per year	(Hee & Hyuck 2010)

Heated floor area and temperature delivered are identified as suitable metrics by many authors (shown in Table 4-1). Further to temperature and area, it would be pertinent to also introduce the dynamic character of the service by including the time for which the service was delivered. Different energy efficiency technologies could then be modelled for how they deliver a unit of this micro energy service and each technology could have a

defined ESEI which would be their energy input required per unit of service output. Service demand could be calculated as an amount of floor area heated to a given temperature for a specified time and by multiplying the ESEI and this service demand, the total energy demand could be calculated as shown in expression (4-2).

$$Q_{demand} = \frac{\text{Energy input}}{\underbrace{\text{service output}}_{ESEI}} \times \text{Service demand} \quad (4-2)$$

An alternative option is to choose an indicative service output for a distinct dwelling, for example maintaining thermal comfort of a specified temperature in a home or rooms of a home for a day, month or year. Technologies can then be compared based on their individual physical contributions to the service delivery, or their contribution to the whole system in which the service is delivered. The energy input required for different energy efficiency technology retrofit options is calculated and included in the total energy input for comparison.

#### 4.2.2 Energy efficiency defined as comparison to ideal demand (EEID)

A definition of efficiency used by Ayres (1998) and Nakicenovic (1993) was a measured or calculated input relative to the minimum theoretical calculated input. Similarly, in their analysis of energy efficiency indicators for HVAC (heating, ventilation and air-conditioning), Perez-Lombard et al. (2012) define service efficiency as the ratio of ideal demand to energy consumed, which in the case of heating efficiency is the ideal thermal demand [kWh]. Cullen et al. calculated the theoretical efficiency limits of conversion devices (Cullen & Allwood 2010b) and passive systems (Cullen et al. 2011) by multiplying the scale of energy flow through each technology by the difference between current and target efficiency. This characterization of efficiency, which is energy efficiency defined as a comparison to ideal demand (referred to in this work as EEID) is expressed in (4-3).

$$EEID = \frac{\text{Minimum theoretical energy input required}}{\text{Actual energy input}} \quad (4-3)$$

The minimum theoretical energy input could be calculated in two ways; either using an idealised version of parameters whereby no heat is lost through walls and only the demanded service is delivered, or using best realistic parameters and the highest possible values for technical efficiency. In both cases, minimum input must be defined for a specific, individual building and its patterns of usage.



### 4.2.3 Energy saving as compared to existing situation (ESES)

A third option for an energy service metric is energy savings, whereby an energy efficiency technology or measure reduces the energy demand to deliver a same service and the change in demand before and after can be calculated. Energy savings are calculated as in expression (4-4); by measuring a ratio rather than an absolute value, the effect of each EEM can be more easily compared between different service level definitions.

$$ESES = \frac{Q_{demand,before\ intervention} - Q_{demand,after\ intervention}}{Q_{demand,before\ intervention}} \quad (4-4)$$

For an energy saving based metric, the technologies are compared based on the scale of intervention required to achieve equivalent energy savings. Further to this, the full realistic range of energy savings attainable for each EEM is calculated and compared.

This comparison of technology interventions is based on the potential for energy (and CO<sub>2</sub>) savings, rather than on the service unit itself, is akin to considering the service of energy savings being delivered by the technologies, rather than only the energy service of HTC.

## 4.3. Identification of technologies

In section 3.1.2, EEMs were classified into their approach to delivering energy service with a lower energy input, and four categorisations were identified; improved conversion device, passive system, service control and service level. From the technologies in Table 3-2, a smaller selection is chosen for the purpose of incorporating these different service delivery options into building modelling, both in this chapter and in Chapter 5.

For the purpose of clearly identifying how a technology is contributing to low carbon heating thermal comfort, a key parameter is defined as the variable particular to each technology or measure which affects the energy efficiency of its contribution to service delivery. The key parameter will be identified for each EEM approach. In order to better understand how the key parameter effects energy consumption, the four EEM approaches are now further described.

### 4.3.1 Conversion device

As a conversion device transforms delivered final energy to a form of useful energy, it is the efficiency of this conversion,  $\eta_{CD}$ , which is the key parameter. Final energy consumption is directly proportional to the efficiency of the conversion device, as shown in equation (4-5).

$$Q_{final} = \frac{Q_{demand}}{\eta_{CD}} \quad (4-5)$$

Where  $Q_{final}$  is the chemical energy of the gas (or other fuel) which is burned, or energy in the electricity consumed [J or kWh] and  $Q_{demand}$  is the heating demand calculated by the building model [J or kWh].

In a house with a hot water central heating system, a boiler converts chemical energy in fuel (typically gas, oil or biomass) to heat in hot water. Hot water is pumped around a house and the heat is delivered to the air in the room by radiators. For a gas-fired boiler, the efficiency of a conventional non-condensing boiler is around 70-75 %, and for a new condensing boiler efficiency can be up to or above 90 %. Therefore, replacing a conventional boiler with new technology can give energy savings of up to 22 %. Boiler efficiency can also be improved incrementally by tuning a heating system; the return water temperature in the wet radiator system is an important factor in achieving optimum efficiency and for a condensing boiler a return temperature below 60 °C is required for the condensing process to work. Below this temperature, efficiency increases as return temperature drops and therefore incremental efficiency improvements can be made with an existing condensing boiler. Based on a figure of boiler efficiency as a function of return water temperature in Oughton and Hodkinson (2008) (figure 10.4 therein), efficiency of a boiler condensing is approximately linear with return water temperature below a return water temperature of 55 °C, with a 10 °C return temperature reduction resulting in an efficiency gain of approximately 4 %.

Electric resistance heaters convert electricity to heat which is delivered directly to the air in a room and are commonly rated as 100 % efficient.

### 4.3.2 Passive system

Heat is lost from a building either through the building envelope (transmittance) or through gaps in the building envelope (air leakage) and an improvement of the passive system can address both factors. The key parameter for addressing the transmittance of a passive system in a building is the U-value (thermal transmittance) which is the reciprocal of thermal resistance. For insulation, U-value can be considered a proxy for thickness of insulation, which can also be considered as a key parameter.

Thermal transmittance,  $U_{ext}$  is inversely proportional to the sum of the resistance of each layer of the thermal envelope as shown in equation (4-6).

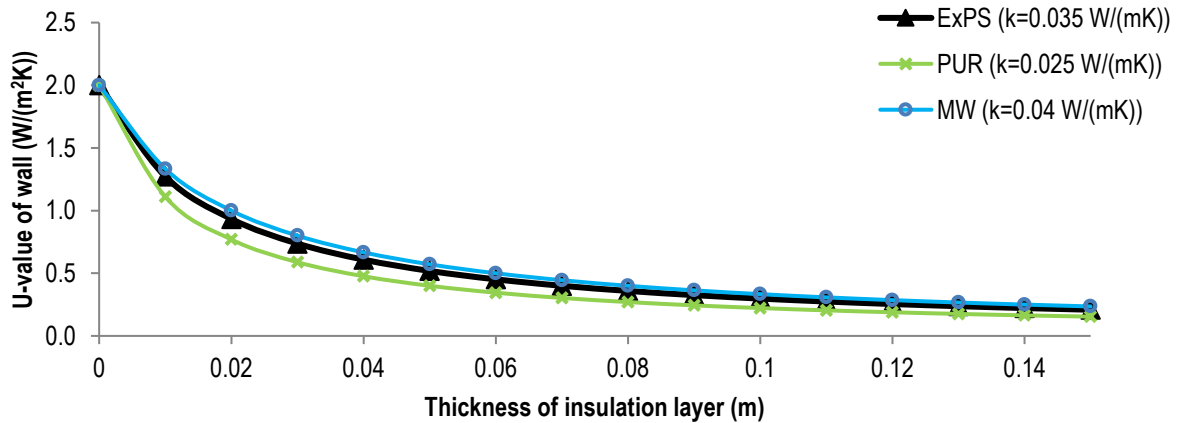
$$U_{ext} = \frac{1}{R_{si} + \frac{\omega_{plaster}}{k_{plaster}} + \frac{\omega_{insulation}}{k_{insulation}} + \frac{\omega_{brick}}{k_{brick}} + R_{so}} \quad (4-6)$$

Where  $R_{si}$  and  $R_{so}$  are the surface resistance for the internal surface and external surface respectively [ $\text{m}^2\text{K}/\text{W}$ ],  $\omega$  is the thickness of each layer of the wall [ $\text{m}$ ], and  $k$  is the thermal conductivity of each layer of the wall [ $\text{W}/(\text{mK})$ ]. The thermal transmittance of the wall is reduced by adding additional layers of insulation to a wall, increasing the thickness of insulating layers ( $\omega_{insulation}$ ) or using insulation with a low thermal conductivity ( $k_{insulation}$ ). For an existing wall, the thermal resistance terms can be condensed into one term,  $\alpha$ , such that equation (4-6) can be re-expressed as equation (4-7).

$$U_{ext} = \frac{1}{\alpha + R_{ins}} \quad (4-7)$$

$$\text{Where } R_{ins} = \frac{\omega_{insulation}}{k_{insulation}}$$

Heat demand is therefore inversely proportional to thickness of insulation and this is a non-linear relationship as shown in Figure 4-1.



**Figure 4-1** Comparison of how thickness of insulation affects the U-value of a wall. Three types of insulation are shown which have different values of thermal conductivity ( $k$ ). ExPS: Expanded Polystyrene; PUR: Polyurethane Insulation Foam; MW: Mineral wool. ExPS is most commonly used in solid wall insulation

Air leakage can occur by ventilation (controlled) or by infiltration (uncontrolled), but when considering the thermal retention of a passive system, infiltration is the factor of most concern. The key parameter is therefore infiltration rate ( $\dot{I}_{air}$ ) which is the rate of air change in a room or a house, commonly measured as the fraction of the total air volume which is replaced every hour (air change per hour, or ach).

Total heat loss through the building envelope ( $\dot{Q}_{d,PS}$ ) [ $\text{W}$ ] is proportional to both external thermal transmittance ( $U_{ext}$ ) [ $\text{W}/(\text{m}^2\text{K})$ ] and infiltration rate,  $\dot{I}_{air}$  [defined by air change per hour (ach) and converted to  $\text{m}^3/\text{s}$ ], and the rate of heat loss depends on the temperature

difference between the internal and external temperature ( $T_{int}$  and  $T_{ext}$  respectively [ $^{\circ}\text{C}$ ]), as shown in equation (4-8).

$$\dot{Q}_{d,PS} = (U_{ext} \cdot A_s + \dot{I}_{air} \cdot V_h \cdot \gamma_{air}) \cdot (T_{int} - T_{ext}) \quad (4-8)$$

Where  $A_s$  is the external surface area [ $\text{m}^2$ ], and  $V_h$  is the volume of the heated space [ $\text{m}^3$ ] with a volumetric heat capacity of air,  $\gamma_{air}$  [ $\text{kJ}/(\text{m}^3\text{K})$ ]. At typical values for an older leaky house (averaged U-value =  $1.5 \text{ W}/(\text{m}^2\text{K})$ , Infiltration rate = 1 ach (for conversion to  $\dot{I}_{air}$  see equation (4-12)), heat loss through walls due to transmittance dominates over heat-loss through infiltration by a factor of 4.

### 4.3.3 Heating control and service level

For heating control, three key parameters are considered: the internal set-point temperature ( $T_{set}$ ) and the length of the heating period ( $t_h$ ), defined for the whole house or varied across different rooms, and proportion of heated area (specifically the proportion under-heated,  $\phi_{uh}$ ). Heating controls can enable heat to be distributed in the house at the right time and at the right level in all spaces of the house. Two types of heating control will be considered; control over internal temperature in spaces around the house enabled by thermostatic radiator valves (TRVs), and control of time of heating enabled by a heating timer). Energy savings can also be enabled by a decision to vary the service being demanded, both in temperature level and in heated floor area. Lower indoor temperature can be deemed comfortable with adaptations by household occupants such as self-heating (wearing a thick sweater or using a blanket). Partial under-heating of the home can be adopted if certain rooms are not frequently occupied; it may be a semi-permanent decision or there may be daily exceptions when the room is occupied for a short period of time. Although these two choices for reducing the demanded service can be carried out without improved heating controls, the presence of controls can make adoption simpler.

## 4.4. Building modelling: quasi steady state

The building model for the work in this chapter calculates the final energy input,  $Q_{final}$ , required to achieve and maintain a set point temperature for a simple one or two zone house for a single heating event or 24 hour period. The model is based on well-established steady state heat transfer, thermodynamic and geometric equations and uses Microsoft Excel to run. The model is quasi-steady state, as the house is modelled both as it heats up from cold and as it maintains a steady temperature. For most of the work in this chapter, a

single zone house is modelled, and this will be explained first. For modelling spatial variation temperature control, a two zone model is used and will be explained subsequently.

#### 4.4.1 Single zone modelling

Single zone modelling is used to investigate technologies (and key parameters) of conversion device ( $\eta_{boiler}$ ), passive system ( $U_{ext}$  [W/(m<sup>2</sup>K)]), service level ( $T_{set}$  [°C]) and timer control ( $\tau_{heat}$  [hours]).

The model is designed such that the effect of the values of all parameters can be investigated and therefore the building is parametrised in as flexible a way as possible. The building geometry is determined in the model by assigning values for the floor area ( $A_f$  [m<sup>2</sup>]), number of floors ( $n_f$ ), height of floors ( $h_s$  [m]), length to width ratio of the house ( $\varphi_{lw}$ ) and number of exposed walls ( $\varepsilon$ ) (4 for a detached house, 3 for semi-detached or end terrace, 2 for mid-terrace). The designation of these values allows the external surface area ( $A_{ext}$  [m<sup>2</sup>]) and internal volume ( $V_h$  [m<sup>3</sup>]) of the house to be calculated, as in equation (4-9) and (4-10) respectively which are required for the subsequent calculations.

$$A_{ext} = \frac{A_f}{n_f} + h_f n_f \varepsilon \sqrt{\frac{A_f}{\varphi_{lw}}} + 2h_f n_f \sqrt{A_f \varphi_{lw}} \quad (4-9)$$

$$V_h = A_f \cdot h_f \quad (4-10)$$

Heat demand is calculated in two parts related to the period in which the house is heating up to set-point temperature, and the period at which this temperature is being maintained.

In the first stage, as internal temperature is increasing, heat loss and internal temperature are calculated over every time step using equation (4-11), where values are designated for external thermal transmittance ( $U_{ext}$  [W/(m<sup>2</sup>K)]), infiltration rate ( $I_{ach}$  [air change per hour (ach)]), external temperature ( $T_{ext}$  [°C]) and humidity of air ( $H$  [kg<sub>water</sub>/kg<sub>dry air</sub>]). Equation (4-12) converts a value of infiltration from air change per hour to cubic metres per second and equation (4-13) calculates the heat capacity of air ( $\gamma_{air}$  [J/(m<sup>3</sup>K)]) from value of humidity using values of specific heat capacity ( $C_p$  [kJ/(kgK)]) and density ( $\rho$  [kg/m<sup>3</sup>]) of dry air and water (values for 20 °C are used as the specific heat capacity and density are not a strong function of temperature at this temperature).

$$\dot{Q}_{loss}(t) = U_{ext}A_{ext}(T_{int}(t) - T_{ext}) + I_{air}\gamma_{air}(T_{int}(t) - T_{ext}) \quad (4-11)$$

Where

$$i_{air}[\text{m}^3/\text{s}] = \frac{V_h[\text{m}^3] \cdot i_{ach} [\text{h}^{-1}]}{3600} \quad (4-12)$$

and

$$\gamma_{air} = \frac{C_{p,air}}{\rho_{air} \cdot 1000} \quad (4-13)$$

Where

$$c_{p,air} = (1 - H) \cdot c_{p,dry\ air}(20^\circ\text{C}) + H \cdot c_{p,water\ vapour}(20^\circ\text{C})$$

$$\rho_{air} = (1 - H) \cdot \rho_{air} + H \cdot \rho_{water\ vapour}$$

The internal temperature is calculated iteratively via the change in temperature ( $\Delta T$  [K]) which is calculated for every time step using equations (4-14) and (4-15). A time step for iteration ( $\delta t$  [s]) must be chosen, and a value for the maximum output of the heating system, ( $\dot{Q}_{max}$  [W]) must be designated.

$$\Delta T(t) = \frac{(\dot{Q}_{max} - \dot{Q}_{loss}(t)) \cdot \delta t}{V_h \cdot \gamma_{air}} \quad (4-14)$$

$$T(t + \delta t) = T(t) + \Delta T(t) \quad (4-15)$$

This iterative process continues from an initial starting temperature ( $T_{cold}$  [°C]) until  $T(t)$  is equal to  $T_{set}$ . The time at which this point is reached ( $\tau_{rise}$  [hours]) is found using the INDEX – MATCH function of Excel. The heating demand for this time period within which the house is heating up ( $Q_{rise}$  [kWh]) is calculated by equation (4-16).

$$Q_{rise} = \frac{\dot{Q}_{max} \times \tau_{rise}}{1000} \quad (4-16)$$

In the second stage, for the remainder of the heating period, the house is treated as steady state and  $\dot{Q}_{sust}$  [W] is calculated by the steady state equation (4-17).

$$\dot{Q}_{sust} = U_{ext}A_{ext}(T_{set} - T_{ext}) + I_{air}\gamma_{air}(T_{set} - T_{ext}) \quad (4-17)$$

The heating demand for this period ( $Q_{sust}$  [kWh]) is calculated as in equation (4-18), where  $\tau_{heat}$  [hours] is the length of the whole heating period.

$$Q_{sust} = \frac{\dot{Q}_{sust} \times (\tau_{heat} - \tau_{rise})}{1000} \quad (4-18)$$

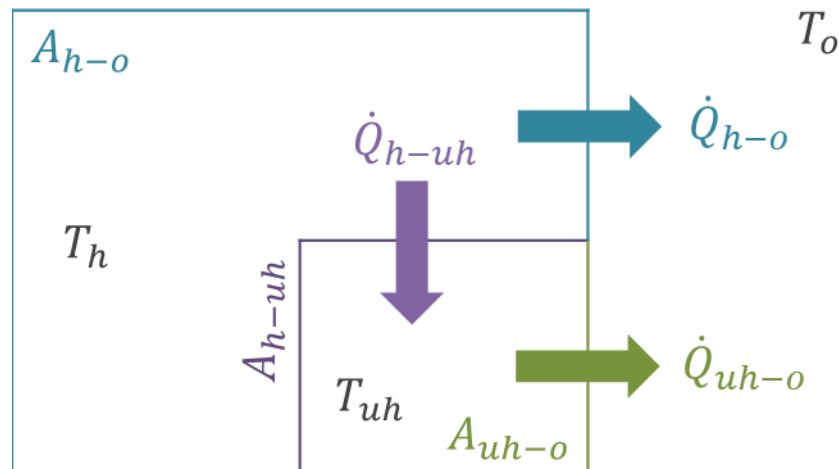
Total heat demand for the entire heating period ( $Q_{heat}$  [kWh]) is the sum of the above two calculated values for heating demand (equation (4-19)), and the demand for final energy is determined via the efficiency of the heating system conversion device,  $\eta_{CD}$ , as per equation (4-20).

$$Q_{heat} = Q_{rise} + Q_{sust} \quad (4-19)$$

$$Q_{final} = \frac{Q_{heat}}{\eta_{CD}} \quad (4-20)$$

#### 4.4.2 Two zone modelling

For the inclusion of spatial heating control, the building model is developed to include two internal zones at different set-point temperatures. Further parameters which are required to be specified are the proportion of the house which is under-heated ( $\theta_{uh}$ ), the number of under-heated zones ( $n_{uh}$ ), and position of under-heated areas within the house (number of internal and external walls), the U-value of internal walls ( $U_{int}$  [W/(m<sup>2</sup>K)]) and air leakage rate from heated zone to under-heated zone ( $\dot{J}_{ach,int}$  [ach]). The geometry of the two zone house is represented in Figure 4-2. Heat flows, ( $\dot{Q}$  [W]) and surface area ( $A$  [m<sup>2</sup>]) are calculated for the interfaces of the heated zones with the outside (h-uh), heated zones with the outside (h-o), and under-heated zones with the outside (uh-o).



**Figure 4-2** Schematic illustrating the heat transfer ( $\dot{Q}$  [W]) and surface area ( $A$  [m<sup>2</sup>]) of the interfaces between heated and heated areas (h-uh), heated areas and outside (h-o) and under-heated areas and outside (uh-o). Temperatures ( $T$  [°C]) for the heated area (h), under-heated area (uh) and outside (o) are also shown.

As in the above approach, heat demand is calculated for both the heating up of the house from cold ( $Q_{rise}$ ), and for the replacement of heat loss to maintain the internal temperature ( $Q_{sust}$ ).

For the calculation of the heating energy required to maintain a steady state within the house, three heat transfers are calculated; from the heated area to the outside ( $\dot{Q}_{h-o}$  [W]) in equation (4-21), from the under-heated area to the outside ( $\dot{Q}_{uh-o}$  [W]) in equation (4-22) and from the heated area to the under-heated area ( $\dot{Q}_{h-uh}$  [W]) in equation (4-23).

$$\dot{Q}_{h-o} = U_{ext}A_{h-o}(T_{set,h} - T_{ext}) + \frac{V_h(1 - \theta_{uh})\dot{I}_{ach,ext}}{3600}\gamma_{air}(T_{set,h} - T_{ext}) \quad (4-21)$$

$$\dot{Q}_{uh-o} = U_{ext}A_{uh-o}(T_{set,uh} - T_{ext}) + \frac{V_h\theta_{uh}\dot{I}_{ach,ext}}{3600}\gamma_{air}(T_{set,uh} - T_{ext}) \quad (4-22)$$

$$\dot{Q}_{h-uh} = U_{int}A_{h-uh}(T_{set,h} - T_{set,uh}) + \frac{V_h(1 - \theta_{uh})\dot{I}_{ach,int}}{3600}\gamma_{air}(T_{set,h} - T_{set,uh}) \quad (4-23)$$

Although a set-point temperature is specified for the under-heated zone, once the house reaches a steady-state the room may be at an equilibrium temperature higher than the set-point. This higher internal temperature for the under-heated area is experienced if  $\dot{Q}_{h-uh}$  is greater than  $\dot{Q}_{uh-o}$  at the under-heated area designated set-point temperature.

**If  $\dot{Q}_{h-uh}$  is less than  $\dot{Q}_{uh-o}$ :**

The heating energy required to maintain a steady state within the house ( $Q_{sust}$  [kWh]) is calculated by equation (4-24).

$$Q_{sust} = (\dot{Q}_{h-o} + \dot{Q}_{uh-o}) \times \tau_{heat} \quad (4-24)$$

**If  $\dot{Q}_{h-uh}$  is greater than  $\dot{Q}_{uh-o}$ :**

An equilibrium temperature ( $T_{uh,eq}$ ), which is higher than the initial set-point, is maintained instead of the under-heated set-point. The equilibrium exists at the temperature for which heat flow into the under-heated zone from the heated zone ( $\dot{Q}_{h-uh}$ ) is equal to the heat loss from the under-heated zone to the outside ( $\dot{Q}_{uh-o}$ ). This equilibrium temperature is a function of the wall area, U-value and air leakage of the internal and external walls, and is shown in equation (4-25). Equilibrium temperature is independent of the under-heated zone set-point and therefore represents a minimum under-heated temperature for a house.



$$T_{uh,eq} = \frac{\beta_{h-uh}T_h + \beta_{uh-ext}T_{ext}}{\beta_{uh-ext} + \beta_{h-uh}} \quad (4-25)$$

Where

$$\beta_{h-uh} = U_{int}A_{h-uh} + V_h(1 - \theta_{uh})I_{air,int}$$

$$\beta_{h-uh} = U_{ext}A_{uh-o} + V_h\theta_{uh}I_{air,ext}$$

To calculate the heating energy required to maintain a steady state within the house, equations (4-22) and (4-23) are recalculated using values of  $T_{uh,eq}$  instead of  $T_{set,uh}$ . The value of  $Q_{sust}$  [kWh] is then determined as in equation (4-26).

$$Q_{sust} = (\dot{Q}_{h-o} + \dot{Q}_{h-uh}) \times \tau_{heat} \quad (4-26)$$

As a simplification, the heating up period,  $\tau_{rise}$ , is assumed to be short enough to not require that the dynamic variation in temperature be included within calculation of  $Q_{sust}$  (internal temperature is assumed to be the set-point throughout). For the present model, the heat required to raise the temperature of the house,  $Q_{rise}$ , is calculated in steady state for the heated and under-heated areas separately as in equation (4-27) and (4-28) respectively, with the total calculated in equation (4-29). The value of  $T_{uh}^*$  in equation (4-28) is dependent on the equilibrium state of the house, and values  $T_{set,uh}$  or  $T_{uh,eq}$  are used as appropriate based on the above cases.

$$Q_{rise,h} = V_h \cdot (1 - \theta_{uh}) \cdot \gamma_{air} \cdot (T_{set,h} - T_{cool}) \quad (4-27)$$

$$Q_{rise,uh} = V_h \cdot \theta_{uh} \cdot \gamma_{air} \cdot (T_{uh}^* - T_{cool}) \quad (4-28)$$

$$Q_{rise} = Q_{rise,h} + Q_{rise,uh} \quad (4-29)$$

As for the one zone model, the total heating energy and total final energy demand are calculated as in equations (4-19) and (4-20).

### 4.4.3 Parameters for building modelling

The default values for parameters used in modelling are given in Table 4-3; these values are used unless otherwise stated.

*Table 4-3 Default values for model parameters*

Symbol	Unit	Default value	Description
$A_f$	$m^2$	98	Floor area of house
$h_f$	$m$	2.5	Height of one floor of house
$n_f$	—	2	Number of floors of house
$\varphi_{ls}$	—	1	Ratio of length to width of house (shape descriptor)
$\varepsilon$		4	Number of exposed walls
$\delta t$	$s$	10	Time step for temperature iterations
$\dot{Q}_{max}$	$kW$	8	Maximum heating power of heating technology
$U_{ext}$	$W/(m^2K)$	1.5	Thermal transmittance of external walls
$U_{int}$	$W/(m^2K)$	1	Thermal transmittance of internal walls
$\dot{I}_{ach}$	$ach$	0.75	Infiltration rate of air from outside (one zone)
$\dot{I}_{ach,ext}$	$ach$	0.75	Infiltration rate of air from outside (two zone)
$\dot{I}_{ach,int}$	$ach$	0.2	Internal air exchange rate between rooms (two zone)
$\tau_{heat}$	$hour$	8	Length of heating period
$T_{ext}$	$^{\circ}C$	5	External temperature
$T_{set}$	$^{\circ}C$	21	Set-point temperature of heated space (one zone)
$T_{set,h}$	$^{\circ}C$	21	Set-point temperature of heated space (two zone)
$T_{set,uh}$	$^{\circ}C$	14	Set-point temperature of under-heated space (two zone)
$T_{cold}$	$^{\circ}C$	14	Temperature of space before heating
$H$	$kg/kg$	0.4	Humidity of air in house
$c_{p,dry\ air}$	$kJ/(kgK)$	1.00	Heat capacity of dry air
$c_{p,water}$	$kJ/(kgK)$	1.86	Heat capacity of water vapour
$\rho_{air}$	$kg/m^3$	1.28	Density of air
$\rho_{water\ vapour}$	$kg/m^3$	0.80	Density of water vapour
$\theta_{uh}$	—	0.6	Proportion of house under-heated
$n_{uh}$	—	1	Number of under-heated spaces
$\eta_{CD}$	—	0.75	Efficiency of heating system conversion device

## 4.5. Exploration of energy service metrics

The three energy service metrics identified in section 4.2 will each be used to compare technologies described in section 4.3 using the building model outlined in section 0. The development of each metric is given below, including specific methodology of its modelling. It is then used as a metric to compare EEMs with results presented and discussed thereafter.

### 4.5.1 Energy service energy intensity (ESEI)

#### 4.5.1.1 *Determination of a service unit*

Further exploration into the examples of energy service efficiency as displayed in Table 4-1 show that many are calculated backwards, taking an overall energy usage and dividing by some proxy for service such as heated floor area, temperature or heated degree days. These proxies themselves do not define a service which an occupant would recognise, and service of heated thermal comfort in the case of this thesis is defined to be a space being at a desired temperature whilst occupied. This definition of service lends itself to a service unit of unit area, time and temperature being used, or 1 m<sup>3</sup> of air being heated by 1 °C for 1 second. For such an approach to be used, the ESEI of each technology configuration could be calculated, allowing for it to be multiplied by the service demand which would be made up of a sum of the total area multiplied by the occupied time and the temperature increase.

The calculation of energy required to deliver a unit-Area-Temperature-Time is perhaps most straightforward for a conversion device as the energy required to heat up a space by a specified temperature increase can be directly calculated, provided the specified heat capacity of the space is known. Generally, this could be approximated as air of a given humidity (although in some cases furniture or other objects within the space should also be taken into account). However, when considering the dynamics of the entire house over the heated period, heat will be lost from each heated space (room), and therefore the heat demand will mainly be a function of heat loss, a factor which is outside the bounds of the conversion device and instead depends on the passive system.

For the consideration of the passive system, and the energy required to deliver a unit-Area-Temperature-Time, heat retention by the building envelope cannot easily be generalised to a contribution to a unit heated floor area as it is dependent on the shape and size of the house. When considering energy input to the technology, a passive system requires no direct final energy, only indirect energy embodied in the materials added to the thermal

envelope. The other contribution is a negative heat demand, as insulation contributes 'negawatts' of avoided energy demand.

Heating control can affect the energy which is demanded as it can ensure that the space, temperature and time of service delivered are matched to the space temperature and time demanded. However, it cannot itself contribute to the calculation of a unit-Area-Temperature-Time service unit. Both improved heating controls and a change in service level contribute to a change in service delivered and matching this to what is desired rather than allowing a unit-Area-Temperature-Time to be delivered with a lower ESEI.

A unit-Area-Temperature-Time service unit is therefore not found to be a useful metric for measuring the contribution of individual technologies to a unit of service as none of the technologies can be considered independently. The analysis of technologies working together as a system requires an understanding of the context of the specific house as it depends on the shape, size, thermal resistance and usage.

As an alternative service unit, a meso level of daily service demand will therefore be adopted for the present work. This will be a description of an individual dwelling at a defined service level of occupied space and time for a period of one day. For the simplified model used within this chapter, occupied space will be considered as a fraction of the total floor area of the home and an occupied temperature will be designated. In further work in subsequent chapters when applied to a more dynamic building model, this can be extended to different temperature profiles defined in different rooms of the house and varied for different days of the week and for different types of occupants.

#### *4.5.1.1 Methodology*

For the comparison of technological contributions to delivering a service at a lower level of energy, a specified house is defined. The functional unit is stated as the heating of occupied areas within the house to 21 °C, for one day (24 hour period). In this example, the occupied areas of the house are deemed to be only 40 % of the house, with 60 % of the house being unoccupied at any time. The occupancy of the house is dictated to be 8 hours over night (occupants asleep), 2 hours in the morning (occupants awake), and 8 hours in the evening (occupants awake). The heating energy demand for the whole house is calculated based on different technology improvement scenarios; technologies work together to deliver the service of a warm occupied space, but each can contribute to a lower energy demand. The energy required to deliver this warm space will be calculated for five configurations based on the default house as described in section 4.4.

- a) **No intervention:** The whole house will be heated to 21 °C. All energy is operational energy as existing boiler and house structure are coming to the end of their useful life.
- b) **Improved conversion device:** The house is modelled with the addition of an improved boiler or electric resistance heater. The whole house will be heated and the total energy demand will comprise operational energy and the embodied energy of the new heating equipment. A new high efficiency boiler and an electric resistance heater will each be investigated.
- c) **Improved insulation:** The house is modelled with the addition of improved insulation. The whole house will be heated and the total energy demand will comprise operational energy and the embodied energy of the new insulation. Mineral wool (MW) and expanded polystyrene (ExPS) will each be considered.
- d) **Improved control:** The house is modelled, but instead of the whole house being heated to 21 °C for the full 24 hours, the temperature across the house and the time for which the house is heated will vary according to what is possible with control technologies. The calculation of the total energy demand will comprise operational energy and the embodied energy of the new heating control; TRVs and heating timer.
- e) **Reduced service level:** As an additional comparison option, and in order to include concepts of sufficiency, a reduced demand temperature will be included with an assumption that thermal comfort can be delivered at lower temperature with behaviour changes from household occupants.

For this exploration, the technologies to be compared are listed in Table 4-4, along with the values of their key parameter for modelling.

*Table 4-4 Values of key parameters before and after intervention for technologies used in modelling for calculating energy per service delivery*

Technology	Key Parameter		Value before technology introduction	Value after technology introduction
<b>Whole house insulation</b>	$U_{ext}$	W/m <sup>2</sup> K	1.5	0.5
<b>New condensing gas boiler</b>	$\eta_{CD}$	%	75	90
<b>New electric resistance heaters</b>				100
<b>Thermostatic Radiator Valves (TRVs)</b>	$T_{set}$	°C	21 °C throughout house	21 °C in occupied parts of house, 14 °C otherwise
	$\theta_{uh}$	-	0 (whole house heated)	0.6 (60% under-heated)
<b>Heating timer</b>	$t_h$	hr	House heating all day	House heating at occupied times only (2 hours in morning, 8 hours in afternoon, 8 hours over night)
<b>Temperature reductions</b>	$T_{set}$	°C	21	20

The energy demand for different EEMs is expected to depend on the shape and size of the house. Therefore, following an initial geometry as described in section 4.4, three contrasting house constructions will be modelled. Initially, the floor area of the house will be 98 m<sup>2</sup>, corresponding to the average values in UK statistical data (DCLG 2010). All houses are assumed to be square ( $\phi_{ls} = 1$ ) and consist of 2 floors ( $n_f = 2$ ).

The focus of this thesis is the low carbon delivery of energy service, and therefore the carbon emissions related to service delivery will be calculated; this is most important for analysis when different final energy carriers are being considered. Carbon Dioxide emissions are calculated from the values for final energy consumption using emission indices for gas and electricity (including generation, transmission and distribution, 2015 values); Natural gas: 0.184 kgCO<sub>2</sub>e/kWh, Electricity: 0.500 kgCO<sub>2</sub>e/kWh (DEFRA 2015). In order to include the full energy input to the service delivered, indirect embodied energy in the adopted technologies will be calculated per service unit, and this will be added to the calculated value of direct final energy.

#### 4.5.1.2 Calculation of embodied energy and carbon

Before the modelling of each EEM to calculate its contribution to reducing final energy demand, the indirect energy required to produce each technology is to be calculated, also known as the embodied energy (EE) in the technology. As well as energy input, the

embodied carbon (*EC*) in each technology will be calculated which is the indirect carbon emissions released from the manufacture of the technology.

In this work, EE and EC calculations will be based on existing data for EE and EC of technologies taken from literature and the Inventory of Carbon and Energy (ICE) database developed at the University of Bath (Hammond & Jones 2011b; Hammond & Jones 2011a). The total EE and EC will be converted to EE and EC per unit of service delivered (which is defined in this section as a single day of operation). Rather than dividing by the total number of days in the technology's life time, it is aimed to include only those days in which service of heating thermal comfort is being delivered. This will therefore include only the heating season, assumed to be 1<sup>st</sup> October – 30<sup>th</sup> April.

##### *4.5.1.2.1 Conversion device: condensing boiler and electric resistance heater*

Life Cycle Analysis of Domestic Stirling CHP was undertaken by (Gazis & Harrison 2011). The study calculated EE and EC data for a 24 kW condensing boiler with a 1 kW Stirling engine combined. The engine was found to contribute 23 % of EE and 31 % of EC and therefore this factor is applied to the totals in the paper for the calculations of condensing boiler only: 1.47 MWh of embodied energy, and 282.6 kgCO<sub>2</sub> of embodied carbon (see Table. A-1 for calculations). For comparison, the weight of a new condensing boiler is approximately 40 kg (Worcester Bosch Group 30 CDi Classic Regular model, output 7.7 - 30 kW). Assuming this entire boiler is made of stainless steel, the totals would be 0.63 MWh of embodied energy and 246.0 kgCO<sub>2</sub> of embodied carbon (see Table A-2 for calculations). The assumption that a boiler is purely constructed of stainless steel is not accurate, and many of the other materials have a higher values of EE than stainless steel. For example, the heat exchanger may be made of aluminium which has an embodied energy three times greater than steel (Hammond & Jones 2011b). The former figures are also inclusive of manufacturing energy which would be required to form the boiler out of the constituent metal parts. Therefore, for a 24 kW domestic condensing boiler, the upper value of 1.5 MWh and 283 kgCO<sub>2</sub> will be used in the present study. For a 2 kW electric resistance heater (typical weight 2.5 kg and assumed composition: 95 % Steel, 5 % Nickel), the resulting embodied energy is calculated as 0.11 MWh and embodied carbon as 12.0 kgCO<sub>2</sub>e for six heaters within the house (see Table. A-3 for calculations). The lifetime of a boiler or electric heater is predicted to be 15 years and this represents 3165 days of heating. The embodied energy and embodied carbon per unit of service is therefore calculated by dividing each factor by this value and overall results are presented in Table 4-5.

4.5.1.2.2 *Passive system: insulation*

For the calculation of EE and EC of thermal insulation, mineral wool (MW) and expanded polystyrene (ExPS) will be considered. The EE and EC of ExPS and MW are expected to be disparate due their predominant materials being plastic and glass respectively. Data for embodied energy of insulation has been taken from the Inventory of Carbon and Energy (ICE) database (Hammond & Jones 2011b), given as MJ embodied energy or kgCO<sub>2e</sub> per kg of insulation. Using equation (4-7), for an uninsulated wall ( $R_{ins} = 0$ ) to have a U-value of 1.5 W/(m<sup>2</sup>K),  $\alpha$  must have a value of 0.67 (m<sup>2</sup>K)/W. For the insulated wall to have a U-value of 0.5 W/(m<sup>2</sup>K),  $R_{ins}$  must have a value of 1.33 (m<sup>2</sup>K)/W, where the thickness of insulation depends on the thermal conductivity of the type of insulation used. The calculation of embodied energy and embodied carbon are 9.7 kWh and 2.7 kgCO<sub>2e</sub> respectively for MW and 22.3 kWh and 3.2 kgCO<sub>2e</sub> respectively for ExPS (see Table. A-4 for calculations). For the insulation of a house, the surface area of the house is calculated as the walls and the roof (the floor is assumed in this case to have no heat loss). The surface area is therefore 189 m<sup>2</sup>, and the EE of the insulation installation would be 1,833 kWh<sub>EE</sub> or 4,215 kWh<sub>EE</sub> for MW or ExPS respectively, and EC would be 510 kgCO<sub>2e</sub> or 605 kgCO<sub>2e</sub> for MW or ExPS respectively. Insulation is assumed to have a lifetime of 30 years and therefore this service is assumed to be delivered over 6330 days. The final values of EE and EC per unit service are given in Table 4-5.

4.5.1.2.3 *Service control: heating control*

Timer control can be undertaken with controls on the boiler or a separate programmable timer unit. Spatial control can be achieved with TRVs or an advanced heating control unit. Current data on the embodied energy of advanced heating controls is not readily available, but data on EC has been attainable. Bates and Hazas (2013) found values for embodied carbon of a single point electricity monitor (e.g. Owl without display) and a Househeat (HHFHT-8V) control, at 3.3 kgCO<sub>2e</sub> and 5.4 kgCO<sub>2e</sub> per control device respectively. Therefore, a representative value of 5 kgCO<sub>2e</sub> per heating control is used in this calculation. Heating controls are assumed to have a lifetime of 8 years which gives an EC of 3.7 gCO<sub>2e</sub> per day of the heating season. For the conversion of embodied carbon to embodied energy, the carbon emissions related to electricity consumption in manufacture are used; 3.7 gCO<sub>2e</sub> is equivalent to 0.007 kWh of electricity consumption (DEFRA 2015) (this value would be even lower if values for China are used where carbon dioxide intensity of electricity is higher than in the UK).



### 4.5.1.3 Results

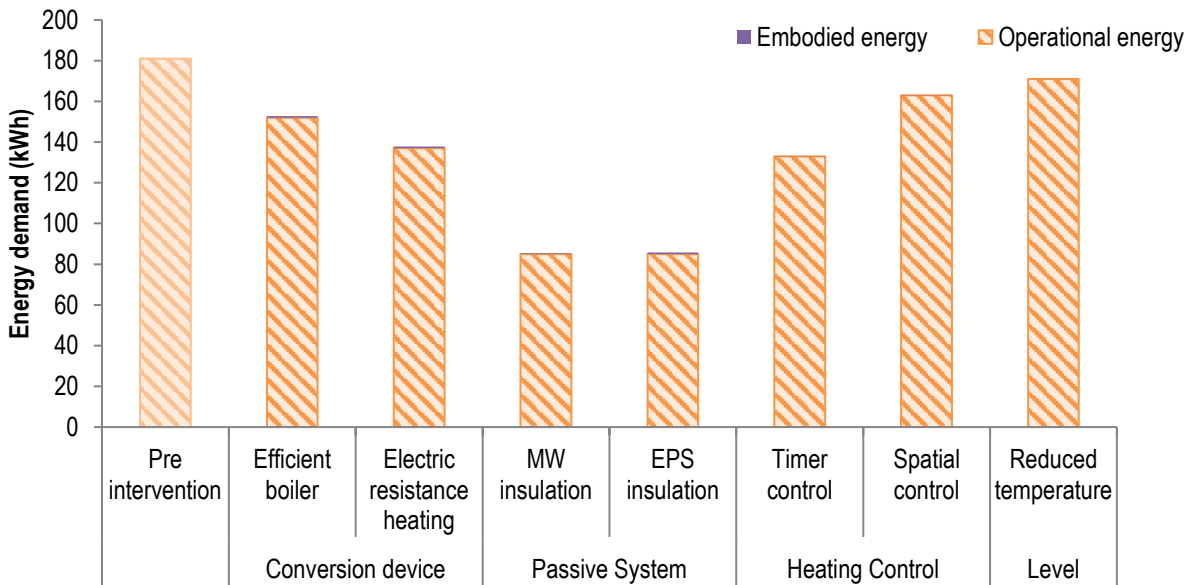
The operational energy required to deliver a unit of service has been calculated for each technology scenario as detailed in Table 4-4 using the model as described in section 0, and these values have been converted to operational carbon emissions using emission indices as specified in section 4.5.1.1. The results are presented in Table 4-5 alongside the results for embodied energy.

*Table 4-5 Results of embodied and operational energy and carbon emissions due to the delivery of defined service of a single day of warm occupied space*

		Energy (kWh)		Carbon emissions (kgCO <sub>2</sub> e)	
		Embodied	Operational	Embodied	Operational
<b>No intervention</b>		-	181	-	33.5
<b>Conversion device</b>	<b>Condensing boiler</b>	0.38	152	0.072	28.1
	<b>Electric resistance heaters</b>	0.035	137	0.008	72.2
<b>Passive system</b>	<b>Mineral Wool</b>	0.33	85	0.09	15.7
	<b>Expanded Polystyrene</b>	0.77		0.11	
<b>Heating Control</b>	<b>Time control</b>	0.007	133	0.0037	24.6
	<b>Spatial control</b>		163		30.2
<b>Service level</b>	<b>Temperature reduction</b>	-	171	-	31.6

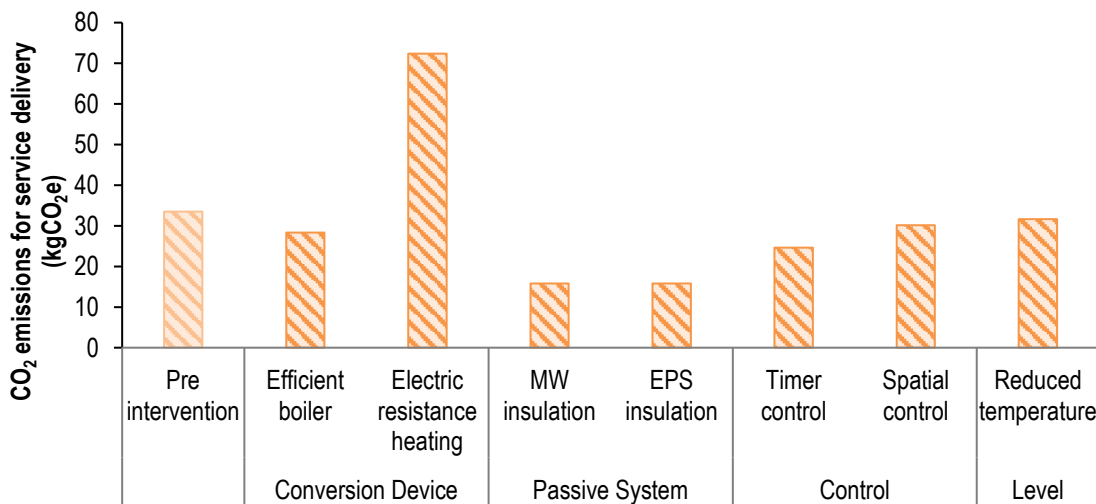
The total operational and embodied energy required to deliver the defined service of a warm occupied space over a period of a day are shown in Figure 4-3 for five technology scenarios. As can be seen, the embodied energy of the technologies is dwarfed by the operational energy in all cases.

Typical values for household gas consumption for heating in a semi-detached house are 8,400 – 14,600 kWh/day (see section 5.6 including Table 5-17 for a more in depth explanation of model validation) which would equate to 40 – 80 kWh per average day over a typical heating season. The model calculated values in Figure 4-3 of 85 – 181 kWh/day are therefore higher than expected. This discrepancy can be attributed to the fact that the calculations are performed in a simplified model for a detached house, heat gains have been omitted (both internal and solar), and the heating period of 24 hours at 21 °C for the whole house is higher than typical usage.



**Figure 4-3** Energy demand for different technology approaches to delivering a service unit of warm occupied spaces at 21 °C for one day. Energy input is distinguished between operational energy and embodied energy in the technology

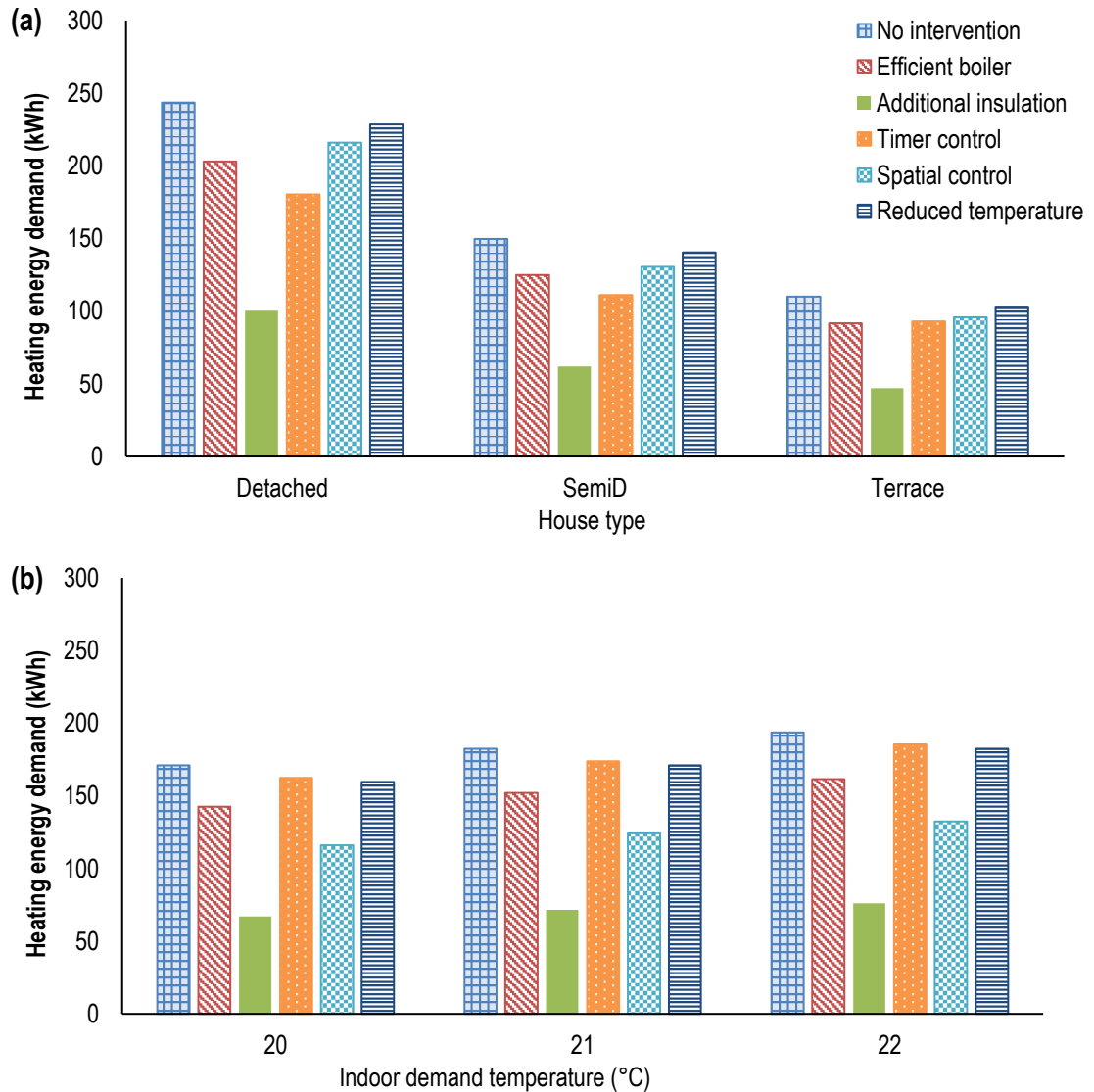
Carbon emissions related to service delivery are presented in Figure 4-4. All energy demand is for natural gas as a final energy source with the exception of an electric resistance heater. Although the efficiency of the electric resistance heater is 100 % (compared to 90 % as maximum efficiency for a gas boiler), the CO<sub>2</sub> content of electricity is far greater than for natural gas and the electric resistance heater therefore has significantly higher CO<sub>2</sub> emission for service delivery than any other configuration.



**Figure 4-4** Carbon Dioxide emissions resulting from delivery of a service unit of a warm occupied room at 21 °C for one day for different technology approaches.

For the comparison of different service demand, energy savings due to EEMs have been calculated for diverse houses (type and size) and demanded temperatures. The results are displayed in Figure 4-5. For the comparison of house type, a detached, semi-detached and

mid-terrace are modelled with average floor area for each house size as taken from UK statistical data (DCLG 2010). The same pattern of heating energy demand has been found in all house types and temperature demand scenarios, with the passive system having the lowest energy demand. Control options give a range of energy demand values, and these are around the same level as the improved boiler.



**Figure 4-5** Energy demand for different technology approaches to delivering a service unit of a warm occupied room for one day for (a) different house types where floor areas are Detached: 147 m<sup>2</sup>, Semi-detached: 93 m<sup>2</sup>, Mid-terraced: 80 m<sup>2</sup> (demand temperature 21 °C); (b) different demand temperature (modelled house is detached house, floor area 98 m<sup>2</sup>).

The definition of service is very important in order for all technology scenarios to be compared on an equal basis. However, this service definition may not accurately reflect service demand, but doing so could require too great a level of detail. TRV control has been set with unoccupied areas at 14 °C, as this simulates these spaces being unheated. In reality, TRVs are generally used to keep unoccupied areas at a lower heat, just a few degrees lower than occupied areas. If unoccupied areas were instead heated to 19 °C, the

daily energy demand would increase by 10 kWh. Heating timing has been for all occupied time, including when occupants would be asleep. However, realistically, occupants require a lower temperature during the night. Insulation has been included as an average for the whole building envelope (except for the floor), but achieving an average U-value of 0.5 W/(m<sup>2</sup>K) is not trivial due to windows and doors having a higher U-value.

## **4.5.2 Energy efficiency as defined as comparison to ideal demand (EEID)**

### ***4.5.2.1 Methodology***

For the comparison of energy consumption with a given technology setup compared to the ideal demand, a value for energy demand in an ideal situation must be calculated. In considering levels of energy saving potential, previous studies have considered different definitions of efficiency optima based on thermodynamic potential, technical potential and economic potential (Jaffe & Stavins 1994; Hammond & Winnett 2006). EEID can be calculated according to equation (4-3), based on the two definitions of minimum input:

- a) Maximum Thermodynamic Efficiency: only the occupied space is heated at any time, no heat is lost through the building shell, and heat input efficiency is 100 %;
- b) Maximum Technical Efficiency: Occupied spaces are heated as could be expected in a house with advanced spatial and temporal heating controls, building envelope heat loss is at the lowest limit of what can be achieved, heat input efficiency is at the higher limit of what can be achieved.

These idealised values are calculated using values of key parameters given in Table 4-6. For each technology improvement scenario, the 'actual energy input' value is taken as the number calculated in section 4.5.1.

*Table 4-6 Values of key parameters for ideal demand modelling*

Technology	Key Parameter		Value for modelling	
			Maximum Thermodynamic Efficiency	Maximum Technical Efficiency
<b>Conversion device</b>	$\eta_{CD}$	%	100	90 (gas boiler)
<b>Passive system</b>	$U_{ext}$	W/(m <sup>2</sup> K)	0	0.3
<b>Timer control</b>	$T_{set}$ $t_h$	°C hr	Daytime <sup>1</sup> heating: 21 °C in 40 % of house Night-time <sup>2</sup> heating: 17 °C in 40 % of the house no heating in other areas and no heat loss between these areas	Daytime heating <sup>1</sup> : 21 °C in 40 % of house, 16 °C in unoccupied 60 % of house Night time <sup>2</sup> heating: 17 °C in 40 % of the house, 14 °C in unoccupied 60 % of house
<b>Spatial control</b>	$\varphi_{uh}$ $T_{set}$	- °C		

<sup>1</sup>Daytime heating for 2 hour and 8 hour period; <sup>2</sup>Night time heating for 8 hr period

For simplification, EE will not be considered as it was shown in section 4.5.1 to only represent a small value compared to direct final energy. However, the implication of this assumption will be considered in the discussion.

#### 4.5.2.2 Results

The values for ideal demand are calculated as 1.72 kWh for maximum thermodynamic efficiency and 29.3 kWh for maximum technical efficiency. Table 4-7 displays the results of the calculation of EEID based on equation (4-3).

*Table 4-7 Energy efficiency of service delivery using metric of comparison to ideal demand*

Energy efficiency measure	Calculated heating demand (kWh/day) ↓ →	Energy demand relative to ideal demand	
		Maximum Thermodynamic Efficiency	Maximum Technical Efficiency
		1.72	29.3
<b>No intervention</b>	181	1.0 %	16.2 %
<b>Conversion device</b>	152	1.1 %	19.2 %
<b>Passive system</b>	85	2.0 %	34.1 %
<b>Timer control</b>	133	1.3 %	22.0 %
<b>Spatial control</b>	163	1.1 %	18.0 %
<b>Temperature reduction</b>	171	1.0 %	17.1 %

As a comparison of technologies, the same results are found as for the ESEI values; the highest efficiency is found for additional insulation. For the metric in reference to idealised demand, the considered options have efficiencies between 1 and 2 %. As the ideal energy

demand values are un-obtainable in any real house, this does not provide useful information about the state of the house; even the maximum technical efficiency value would achieve only 5.9 % efficiency compared to the maximum thermodynamic efficiency. Using maximum technical efficiency values for the key parameters, the technology options have efficiency values between 15 and 35 %. Using maximum technical efficiency values gives a better indication of remaining potential, possibly achievable by combining technology interventions.

### **4.5.3 Energy savings as compared to existing situation (ESES)**

#### ***4.5.3.1 Methodology***

Although technologies are required to work as a system to deliver the service of HTC, their contribution to energy savings can be considered individually. An energy saving metric is used to determine the scale of intervention (ie the change in key parameter) required to achieve equivalent energy savings. The energy saving calculation is also used to compare the broader range of savings possible for each intervention, given the realistic range of each key parameter.

For each intervention, the relationship between key parameters and energy savings is established. For some technologies, the change in key parameter is linearly related to the calculated energy savings and therefore these savings can be predicted independently of the exact service being delivered. For other technologies, the key parameter is not linear and therefore graphs are plotted to explore the relationship between key parameter and resultant energy savings.

For each technology, the required change or contribution of key parameter is calculated for a 1 % and 10 % energy demand saving, thus enabling technologies to be compared in terms of target level of energy savings for the delivered service. Subsequently, the full range of possible savings are identified for each technology with consideration given to starting point and any other influential parameters.

The scope of the key parameters to be modelled is given in Table 4-8. The EE per energy saving is established and the attainable range of energy savings is reconsidered including all energy input. The levels of achievable energy savings are then compared for the different interventions. Modelling is undertaken using the typical house described in section 4.4 unless stated otherwise.

*Table 4-8 Interventions for modelling including lower and upper bound of key parameters*

Intervention	Key parameter		Lower bound	Upper bound
<b>Conversion Device</b>	$\eta_{CD}$	%	70.0	90.0
<b>Passive system</b>	$\omega_{ins}$	cm	0.0	12.5
<b>Reduced temperature</b>	$T_{set}$	°C	23.0	18.0
<b>Reduced heated floor area</b>	$\theta_{uh}$	%	0	60
	$T_{uh}$	°C	21.0	14.0

### 4.5.3.2 Results

#### 4.5.3.2.1 Improved boiler efficiency

Energy consumption is directly proportional to the efficiency of a boiler which can vary between 70 % for a conventional non-condensing boiler (typical range 70-75 %), to 90 % or greater for a new condensing boiler (typical range 85-90 %). Efficiency levels in between can arise based on the heating system and the temperature of the return water.

The technology required to achieve efficiency gains is not proportional to the desired gains. For a house with an existing non-condensing boiler, an entire new boiler unit is needed. For incremental gains through boiler tuning, no additional technology is required. 10 % energy savings can be achieved by approximately 10 % efficiency gains, such as a new boiler installation (75 % efficiency improved to 85 % efficiency). A 1 % saving can be achieved by tuning of the heating system to reduce the return temperature of the heating water.

Assuming an initial boiler efficiency of 70 % and efficiency of a new condensing boiler of 90 %, savings in energy consumption are calculated to be up to 28 %, giving an energy saving by the installation of a boiler of 40 MWh. The embodied energy per energy delivered for a new condensing boiler is thus calculated as  $6.4 \times 10^{-3}$  kWh embodied energy per kWh and 0.030 kWh embodied energy per kWh saved. The uncertainty in this value may be as high as 100 %, but this still reveals that less than 1 % of total energy consumption is in the indirect energy of the boiler and the majority of energy consumption is in the use phase.

In reality, the savings attainable depend on the initial efficiency of the boiler. Figure 4-6 shows the calculated savings for an initial efficiency of 70 and 75 % (typical for a conventional non-condensing boiler) and 80 % (possible for a poorly tuned condensing boiler).

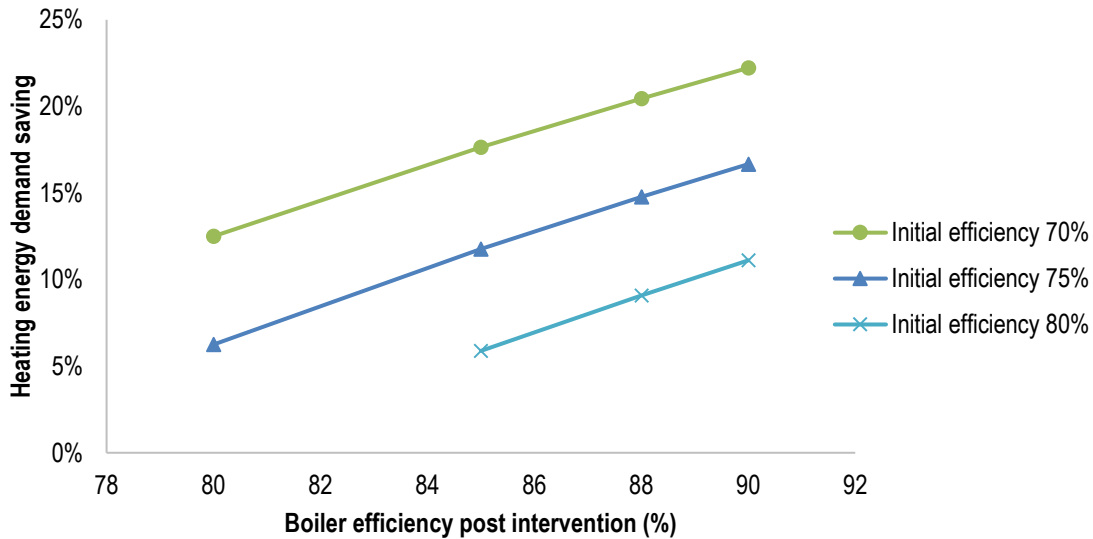


Figure 4-6 Heating energy demand savings for improved boiler efficiency including different values of initial boiler efficiency

The range of energy savings attainable is between 6 % and 22 %.

4.5.3.2.2 Improved thermal insulation

Energy consumption is directly proportional to thermal transmittance (U-value), but thermal transmittance is inversely proportional to the thickness of insulation and therefore the benefit of increasing insulation will tend to a limit. The non-linear relationships between thickness of insulation, U-value of the wall and resulting energy savings are demonstrated in Figure 4-7 for the case of a solid brick wall with three types of insulation (each having a different value of thermal conductivity,  $k$ ).

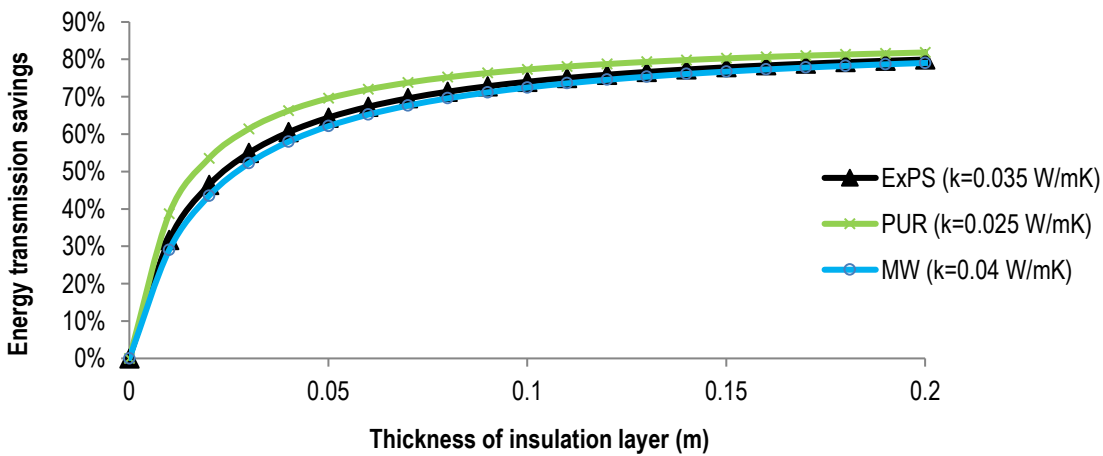


Figure 4-7 Comparison of how thickness of insulation affects the savings on energy loss (including infiltration of 0.7 ach). Three types of insulation are shown which have different values of thermal conductivity ( $k$ ). ExPS: Expanded polystyrene; PUR: Polyurethane, MW: Mineral wool.



The non-linear relationship shown in Figure 4-7 means that the amount of insulation that is required to be added to achieve a 1 % or 10 % energy saving depends on what the baseline thermal resistance is. From a base line of no insulation, only a small layer of insulation (less than 0.01 m) is required. If there is already some insulation on the walls, or greater thermal resistance is delivered by the wall construction, an increased thickness of insulation is required to deliver a 10 % saving.

Theoretically, there is no limit to the increase of insulation possible, but instead practical reasons offer bigger limitations. For external wall insulation, 0.05 - 0.1 m insulation is typically installed (according to the UK government planning advice (UK Government 2014)). Limits on the thickness of internal insulation are imposed by preferences of the householders and the space which can be relinquished.

For the investigation of thermal insulation, MW and ExPS insulation are considered as in previous sections. For the calculation of embodied energy per energy saving, the EE is calculated for a 1 m<sup>2</sup> area of wall to have a thermal resistance of 1 (m<sup>2</sup>K)/W (equal to a U-value of 1 W/(m<sup>2</sup>K)), and the calculations are shown in Table 4-9.

*Table 4-9 Calculation of embodied energy of insulation delivering a thermal resistance of 1 (m<sup>2</sup>K)/W (= U-value of 1 W/(m<sup>2</sup>K))*

Type of insulation	Density	Embodied energy	Conductivity of insulation	Insulation for U-value = 1 W/(m <sup>2</sup> K)		Embodied energy per m <sup>2</sup> wall
	kg/m <sup>3</sup>	MJ/kg	W/(mK)	Thickness [m]	Mass [kg]	kWh
<i>Mineral wool (MW)</i>	48	16.6	0.033	0.033	1.58	7.29
<i>Expanded polystyrene (ExPS)</i>	24	109.2	0.023	0.023	0.55	16.7

For the calculation of energy savings, the reduction in energy loss enabled by an additional insulation resistance of 1 m<sup>2</sup>K/W must be estimated over its useful lifetime. A typical lifetime for thermal insulation is estimated to be 30 years. The energy saving over this time is estimated as in equation (4-30).

$$Q_{\text{saving}} = U_{\text{ext}} \cdot A_s \cdot \int_0^{30 \text{ years}} \Delta T(t) dt \quad (4-30)$$

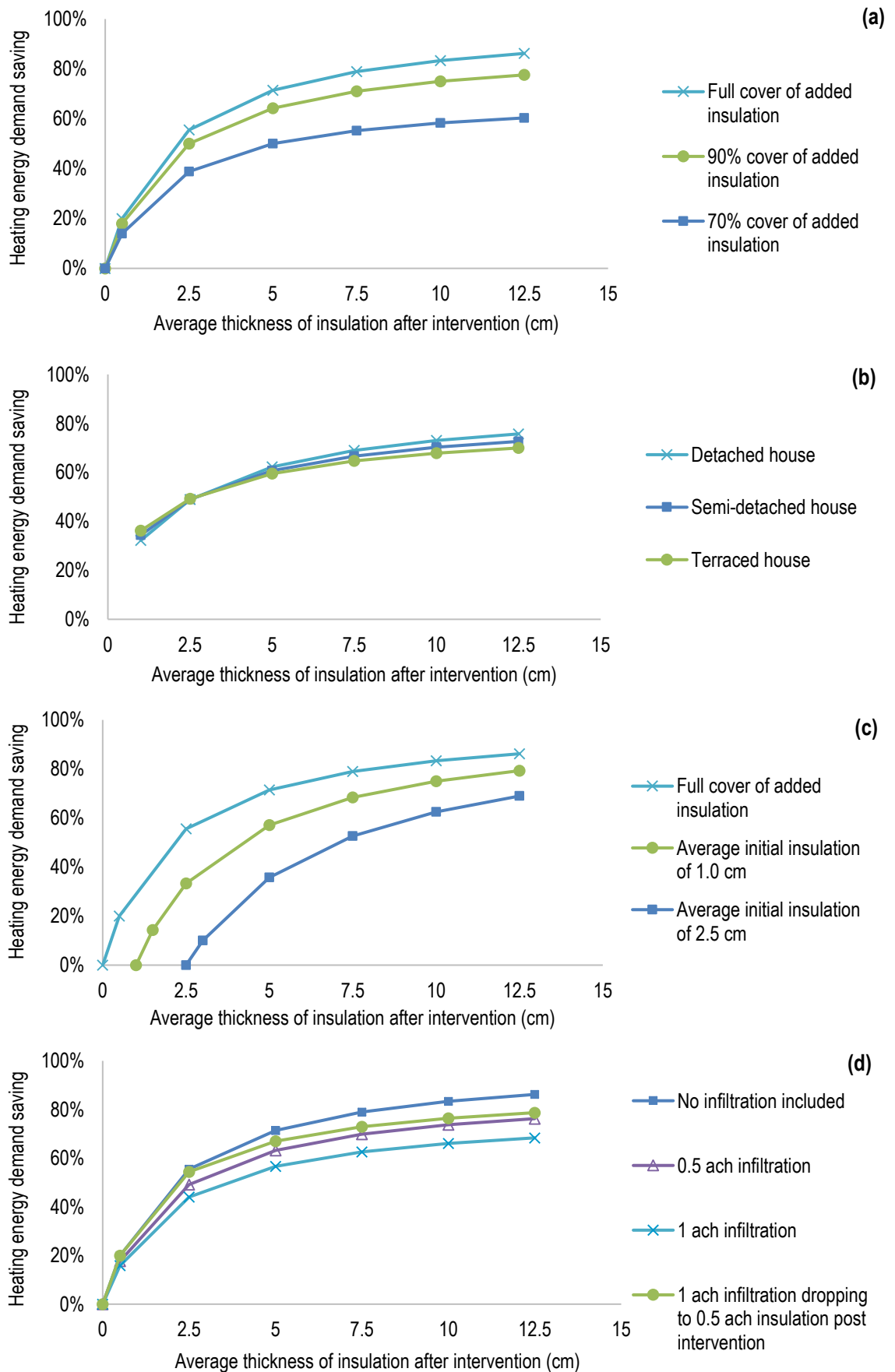
The estimation of the summation of temperature difference over this period is made using heating degree-day (HDD) data. A base temperature of 19 °C is used to represent an average internal temperature during the heating season. An average value of HDDs for a location in the South East of England is 2500 °Cdays/yr. Over 30 years, the value of the summation in equation (4-30) is 1.8 × 10<sup>6</sup> °C hr, giving a saving of 1.8 MWh per 1 m<sup>2</sup> of

wall area. The embodied energy within the insulation per energy saved is presented in Table 4-10. For both mineral wool and expanded polystyrene, the embodied energy is less than 1 % of the energy saved.

*Table 4-10 Calculation of embodied energy per energy saving for insulation*

Type of insulation	Embodied energy per m <sup>2</sup> wall	Energy saving per m <sup>2</sup> wall	Embodied energy per energy saving	
	kWh	MWh	kWh <sub>EE</sub> /MWh <sub>saved</sub>	%
<b>Mineral wool (MW)</b>	7.29	1.8	4.05	0.41
<b>Expanded polystyrene (ExPS)</b>	16.7		9.28	0.93

Attainable energy savings depend on a number of aspects; Figure 4-8 shows the effects of percentage of insulation cover, thickness of initial insulation and infiltration levels on calculated values of energy savings.



**Figure 4-8** Energy savings attainable for additional thicknesses of insulation, including effect of (a) proportion of insulation cover (to allow for effects such as thermal bridging), (b) type of house, (c) effect of initial level of insulation, and (d) infiltration rate.

The effect of reduced insulation cover is shown to lower energy savings by up to 26 %. Thus far, this chapter has considered an average U-value for the whole house, but reduced insulation cover can represent the effect of poor efficiency windows or thermal bridging. The potential energy savings are greater for a larger detached house than a smaller mid-terrace house. Energy savings are reduced if the house already has some level of insulation; in Figure 4-8(c), with no initial insulation, an additional 5 cm gives a saving of 71 %, whereas with a starting level of 2.5 cm insulation this saving is found to drop to 53 %. Infiltration is shown to reduce energy savings in Figure 4-8(d), and an additional 7.2 % of savings is shown if infiltration rates are decreased by the installation of insulation, showing a reduction in infiltration rates from 1.0 ach to 0.5 ach.

A maximum energy saving is calculated for 10 cm of MW insulation at 90 % insulation cover and an infiltration rate falling from 1 ach to 0.5 ach following insulation; energy savings are calculated at 72 %. There is no minimum amount of insulation which would be installed, but 1 cm of MW insulation over 20 % of the building envelope and no change in infiltration still affords a 5 % energy saving and therefore this will be considered as the minimal end of the savings scale.

#### 4.5.3.2.3 *Decrease in temperature set-point*

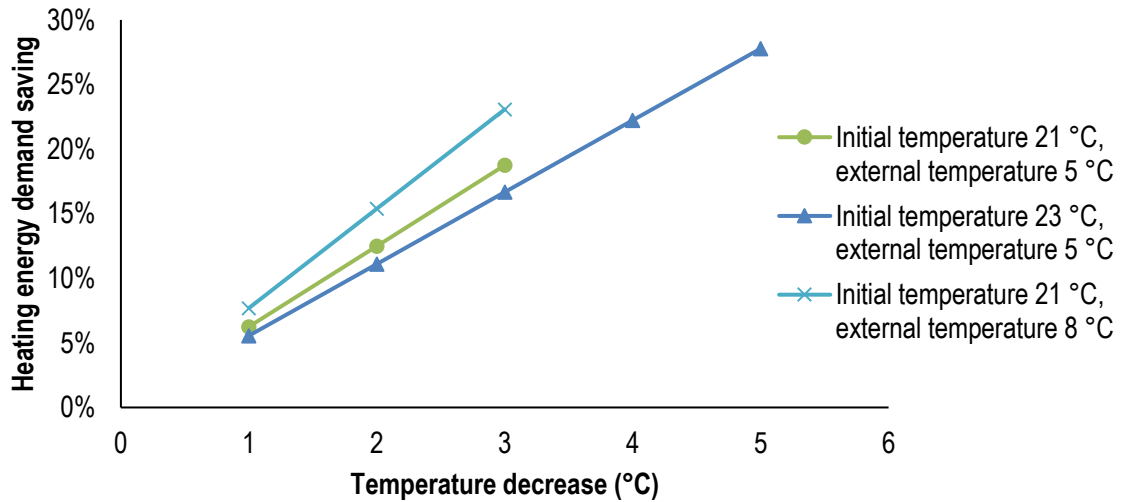
As internal temperature decreases, required energy will decrease. The independent variable driving energy loss is the temperature difference between internal and external air temperature; whilst external temperature cannot be controlled, internal temperature can be. Energy savings are therefore not proportionate to the reduction in internal temperature, but to the reduction in temperature difference, as given in equation (4-31).

$$\text{Energy saving (\%)} = \frac{T_{\text{initial}} - T_{\text{reduced}}}{T_{\text{initial}} - T_{\text{external}}} \quad (4-31)$$

Due to wide temperature variations in the UK climate, a 1 % energy saving cannot be predicted as the uncertainty in  $T_{\text{ext}}$  is too great. However, for a 10 % saving over a winter period (of average temperature 5 °C), a temperature reduction of 1.6 °C (from 21 °C) would be required.

In order to identify an upper limit of the energy savings attainable through internal temperature reduction, a safe minimum internal temperature should be considered, below which health can be negatively impacted; Public Health England recommend that this minimum temperature should be 18 °C (PHE 2014). Therefore, an upper limit of the energy savings attainable through internal temperature reduction (from an initial internal temperature of 21 °C and winter average temperature 5 °C), would be 18 %.

The effect of initial internal temperature and average external temperature on energy savings are shown in Figure 4-9. Potential savings are shown to be lower per reduced temperature degree for reduction from a higher starting point. A higher average external temperature is revealed to increase the attainable energy savings.



**Figure 4-9** Energy savings attainable for temperature set-point decrease. Different lines show effect of initial internal temperature and average external temperature.

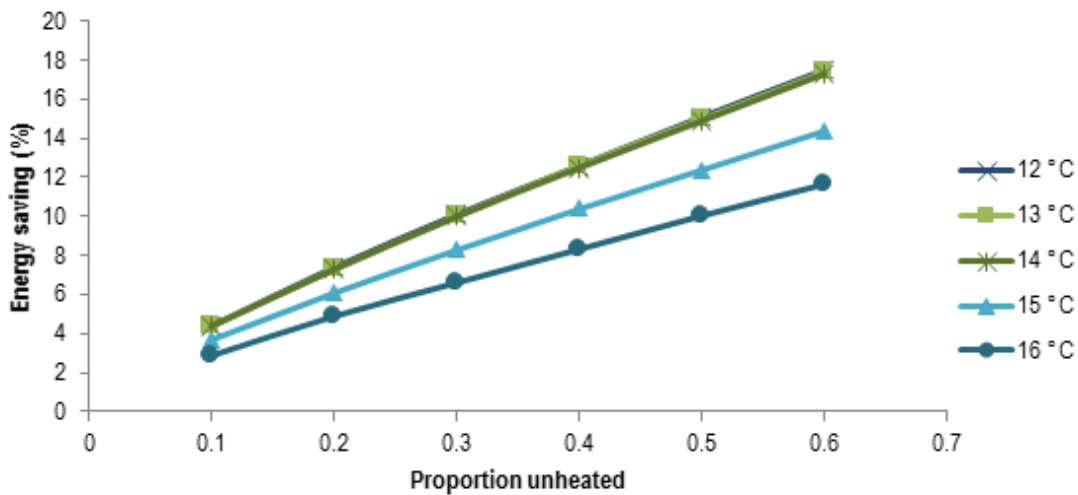
The results shown in Figure 4-9 indicate that energy savings of up to 28 % are possible. However, realistically, a temperature reduction of 2 °C is a realistic maximum and is found to have a maximum saving of 15 %. There is no minimum to the achievable savings, as any temperature reduction will have some effect on reducing energy demand.

#### 4.5.3.2.4 Reduced heated floor space

When considering the energy savings for reduced heated space, the initial hypothesis could be that energy for heating is proportional to the space heated, and therefore to save 10 % of energy, one tenth of the house could be un-heated. However, 'un-heated' spaces still require some heating and a safe lower temperature of 12 °C is used for an unoccupied space as a recommended minimum internal temperature to protect against problems of condensation and mould (BSi 2005). On top of this, heat loss occurs from heated to unheated spaces, and therefore the term 'under-heated' is more appropriate than suggesting these spaces are not heated at all. The intervention of reduced heated floor space has two key parameters; proportion of space under-heated and temperature of under-heated space. Energy savings are not proportional to these key parameters and therefore further analysis is required to understand the scale of energy demand saving achievable through reduced heated floor spaces.

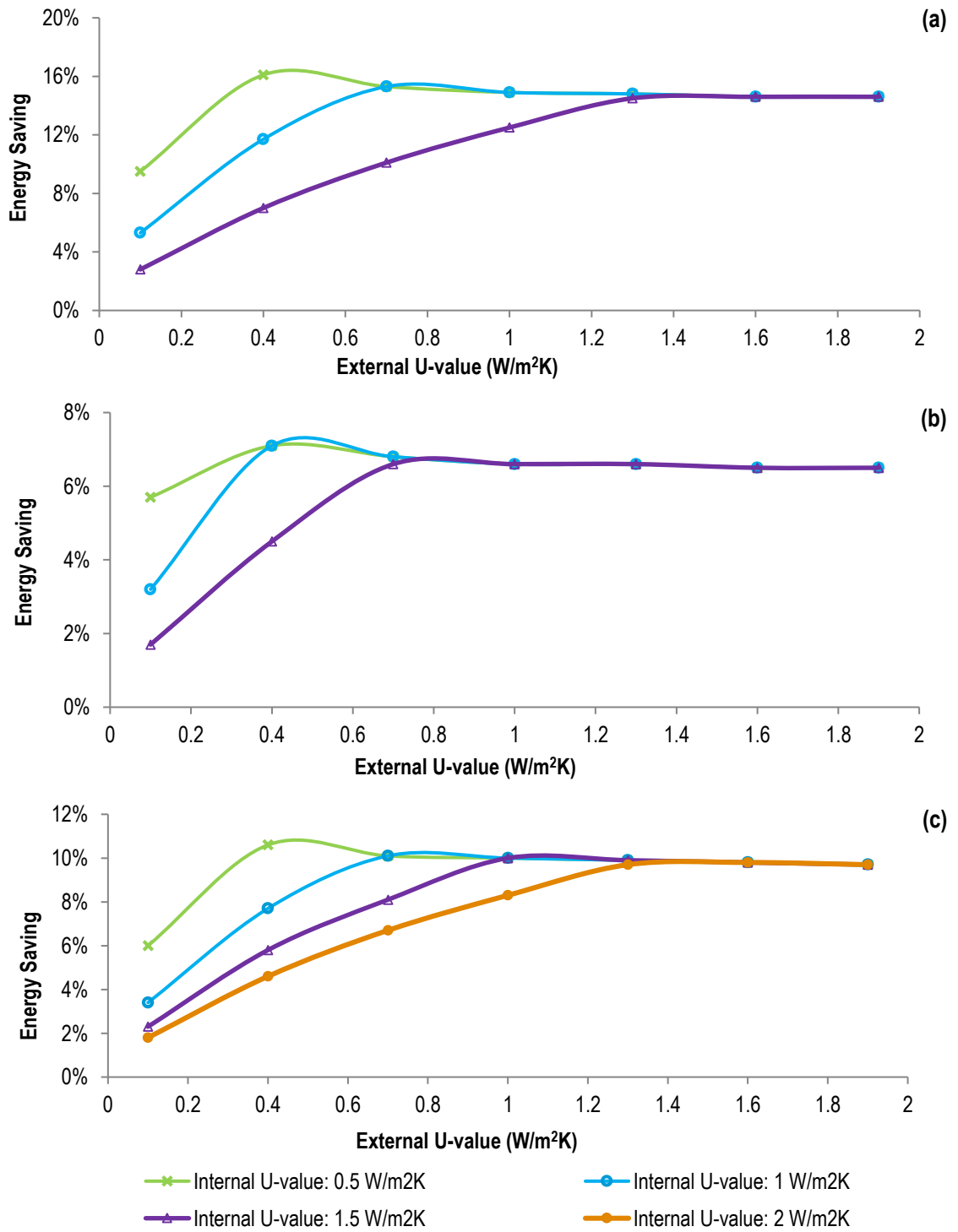
Energy savings attainable by reduced heated floor space are plotted in Figure 4-10 for different under-heated temperatures. Energy savings are shown to be linearly related to the

proportion of the house under heated. Greater savings are calculated for a lower under-heated temperature, but only to a limit; similar energy savings are calculated for under-heated temperature of 12, 13 or 14 °C due to heat transfer from the heated to the under-heated space through the internal walls. Temperatures converge when the heat transfer from the heated spaces to the under-heated spaces is greater than the heat transfer from under-heated spaces to the outside. The value at which under-heated temperatures converge (shown in Figure 4-10 to be 14 °C) is the equilibrium temperature as defined in section 4.4.2 which is a function of the external U-value, internal U-value, and wall area between heated and under-heated space (dictated by arrangement of rooms and number of rooms under-heated), and is independent of the temperature set-points in the heated or under-heated spaces.



*Figure 4-10 Influence of proportion of house which is under-heated on the energy savings at difference values of internal temperature of under-heated space*

Energy savings are investigated as a function of internal and external U-value, and these results are shown in Figure 4-11. Figure 4-11 shows that greater energy savings are attained for higher values of external U-value (greater heat transmission) and for lower values of internal U-value (greater thermal resistance). At higher external U-value, the energy savings tend to a constant value, which is governed by the under-heated floor area and temperature. A maximum possible energy saving is identified as 17 %, enabled by an under-heated proportion of 60 % at a temperature of 14 °C. There is considered to be no minimum energy saving achievable.



**Figure 4-11** Energy savings for partial heating as a function of U-value of external and internal walls. Plots show energy savings for (a) 50 % under-heated floor area, under-heated temperature of 14 °C, (b) 30 % under-heated floor area, under-heated temperature of 16 °C, (c) 30 % under-heated floor area, under-heated temperature of 14 °C.

### 4.5.3.3 Comparison of attainable savings for technologies

The range of savings calculated for the four technology led approaches to heat management are compared in Figure 4-12, showing the range between the minimum and maximum attainable savings.

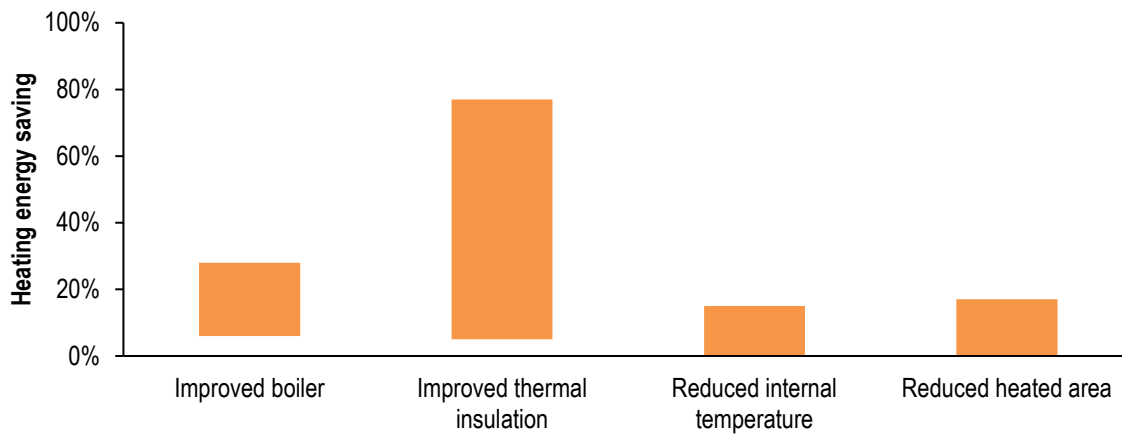


Figure 4-12 Range of savings attainable with heat management options

Improved thermal insulation has shown the widest range of savings, with savings potential up to 72 %. The other three approaches show savings potential up to around 20 %. As a service measurement metric, energy savings allows the range of attainable savings to be compared, with the range representing different existing situations and extent of implementation.

## 4.6. Discussion

The objective of this chapter has been the development of metrics to compare how different technical approaches to heat management can deliver heating thermal comfort with a reduced energy input. For a metric of Energy Service Energy Intensity (ESEI), it was determined that a meso service demand definition is more appropriate than consideration of a micro service unit. Technologies work together within a house to deliver HTC and therefore a single conversion device or passive system cannot be analysed as delivering a unit area at a unit temperature difference for a unit time on its own. Measuring their contribution to a micro-unit metric based on a unit Area-Temperature-Time is therefore not appropriate. Instead, by calculating the energy required to deliver a specified level of service for a fixed period allows for technologies to be compared based on how their installation can contribute to an energy demand reduction within the whole system. A



benefit of ESEI is that it is a clear presentation of the results of the model and allows different technology configurations to be compared without a specific need for the initial situation to be known. However, out of context, and without comparison to other technology configurations, the energy consumption values do not give a clear and meaningful indication of the effectiveness of a technology.

As a comparison metric, Energy Efficiency compared to Ideal Demand (EEID) allows technologies to be compared to each other as well as the whole house system to be compared against its overall potential. It was considered that the definition of an ideal demand was most appropriate based on 'maximum technical efficiency' values of technology parameters rather than for 'maximum thermodynamic efficiency' values. The highest calculated values of EEID was for the improved insulation and this had an energy efficiency of 34 %. The benefit of EEID is that the overall result gives a clear indication of the effectiveness of the current system and the remaining potential to reduce CO<sub>2</sub> emissions. It does not take into account the other non-technical barriers to realising energy efficiency which would compromise the capability of more easily reducing energy demand and CO<sub>2</sub> emissions, however these barriers will need to be overcome in additional non-technical ways.

Energy Saving compared to an Existing Situation (ESES) as a metric fits with the ambition of reducing energy consumption. As a ratio rather than an absolute saving value, ESES makes the results comparable between different types of technology for different definitions of service demand. The approach chosen for ESES in section 4.5.3 shows the range of energy saving potential rather than a single value. Results are very sensitive to the initial state of the house, for some technologies more than others, and therefore this information is required in order to make accurate calculation of expected energy saving for any technology type.

All metrics have shown that improvements to the passive system have the greatest potential for saving energy and delivering the service of HTC with a lower energy demand and CO<sub>2</sub> emissions. As the same overall results can be gained from each of the considered metrics, the exact metric used is not expected to affect conclusions made with respect to recommending EEMs for domestic retrofit.

Energy demand calculation is used as a proxy for CO<sub>2</sub> emissions, but the source of final energy is therefore important. The effect of final energy type on CO<sub>2</sub> emissions was illustrated in section 4.5.1, where an electric resistance heater with a 100 % conversion efficiency was included in the comparison. Despite enabling a reduction in energy demand, Figure 4-4 shows the electric resistance heater leads to significantly higher CO<sub>2</sub> emissions due to the high carbon index for electricity. Embodied energy and carbon were

calculated for all technologies based on a service unit of a day of operation. For all technologies, the embodied energy and carbon were less than 1 % of the overall energy consumption and this demonstrated that the majority of energy is in the direct final energy delivering the service.

This chapter has been based on physical equations, without any consideration of more nuanced aspects of home energy consumption. Simplifications have included the neglect of heat gains which also contribute to satisfying energy demand, the use of a constant average value for external temperature rather than a continually changing value and the neglect of thermal capacity of the building. The large number of simplifications means that the results calculated are not expected to represent energy demand levels or savings in reality. In the next chapter, the building energy model is more sophisticated and includes other aspects of house energy use. Calculated values are also compared to measured values to gain a sense of the accuracy of the model.

## **4.7. Conclusion**

The aim of this chapter has been to identify a metric by which technologies can be compared based on their contribution to delivering a service of HTC with a lower energy demand and resulting CO<sub>2</sub> emissions. In the next chapter, ESEI and ESES metrics will be used to compare energy efficiency technologies and measures for delivering HTC energy service. Within this chapter, technologies have been compared using a simple quasi-steady-state building model and therefore the results generated are of limited validity. In the next chapter, heating energy demand and energy savings will be considered for energy efficiency measures, including in combinations, using a more sophisticated computer building energy model. Due to the negligible contribution of embodied energy and carbon calculated in this work, these are no longer taken into account in the next two chapters.

# Chapter 5 Energy savings for energy service defined by occupancy pattern

## 5.1. Introduction

The aim of this chapter is to compare how energy efficiency technologies and measures (EEMs) contribute to energy savings within a typical UK house for different definitions of energy service. Due to insight gained in Chapter 4 that energy service definition is best made as a meso level description of demand time and temperature, energy service is defined by three hypothetical household occupancy pattern scenarios which are common in the UK. As in Chapter 4, four approaches to improving energy service efficiency are compared, and these remain as interventions of conversion device, passive system, service control and service level. Technologies are modelled singly and also in representative combinations. In order to calculate energy demand values before and after EEM interventions, a model of a typical UK 'hard-to-treat' house is developed using TRNSYS, a commercially available and well used building energy model. The modelling of the EEMs is based on literature data from academia and industry in order to attain the most likely values for model parameters before and after an intervention is adopted.

The following three sections cover the methodological approach to combining aspects of building modelling (section 5.2), service demand (section 5.3) and technologies and energy efficiency measures (section 5.4). The results section (5.5) begins with an investigation of calculated heating energy savings achieved with a range of values within each type of EEM. This is followed by a comparison of the different EEMs and a comparison of savings according to occupancy type. The results of the model are tested in section 5.6 through comparison of calculated results against expected values taken from literature, and sensitivity analysis of the model. The findings from the modelling work are then discussed in section 5.7 and finally the chapter is concluded in section 5.8.

## 5.2. Development of building model

### 5.2.1 Description of building model

For the modelling of energy savings for different EEMs, TRNSYS (TRansient SYstem Simulation) modelling software is used. TRNSYS is a dynamic simulation software which performs energy balance calculations using transient thermodynamic equations. Its merits are in testing the performance of the different parts of the HVAC system and passive design techniques. Components representing a mathematical description of a sub-system, equipment, or thermal and mass transfer process are compiled and assembled to enable a full building simulation. The flexibility enabled by the modular design of TRNSYS is particularly useful for describing novel systems (Abaza 2008; Al-Homoud 2001; Crawley et al. 2008; TRNSYS 2013; Bradley & Kummert 2005; US Department of Energy 2013).

TRNSYS is made up of a suite of programmes; TRNSYS3D is a plug in to GoogleSketchup® which allows the building geometry to be defined, TRNBuild is the interface for the definition of multi-zone building project, and TRNSYS Studio Project is the main visual interface within which projects can be put together. For the rapid comparison of energy efficiency technologies and measures as well as occupancy characteristics, model parameters are specified within a Matlab script developed by the author for this project. The Matlab script edits the TRNSYS input files, calls the TRNSYS simulation to run, and undertakes analysis of the results. The modelling process of simulating the house is shown in Figure 5-1 and the parts of the process are described in Table 5-1. The model process is described in greater detail within Appendix B.1.

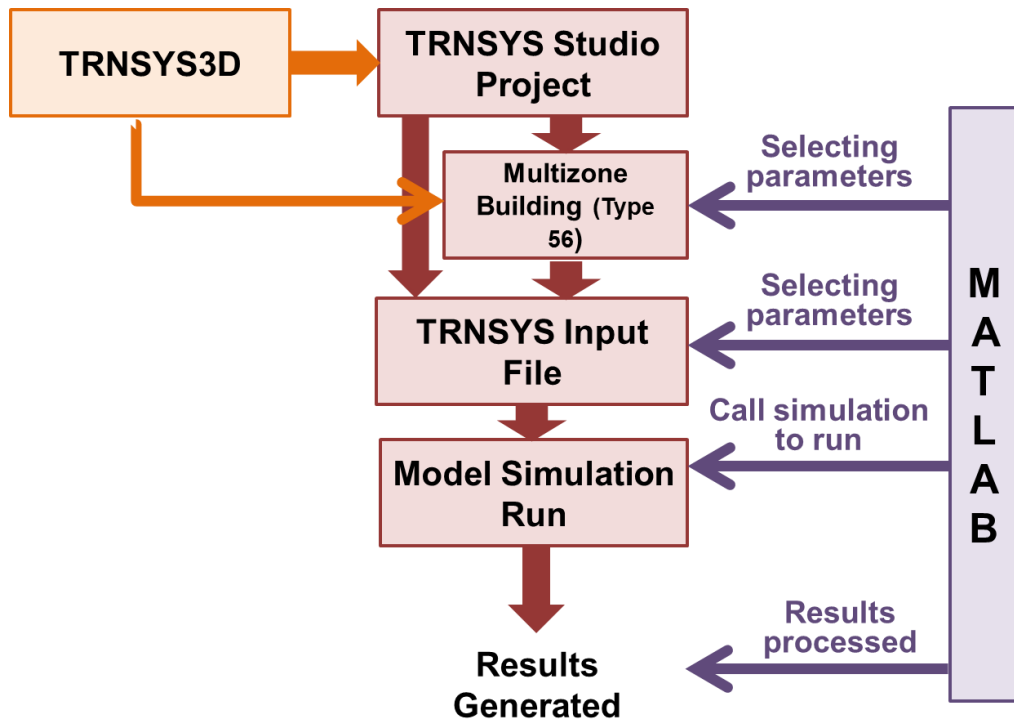


Figure 5-1 Building modelling process

Table 5-1 Description of parts that make up the building modelling process

Part	Description	Program	File generated
TRNSYS3D	Detail building geometry and all adjacent walls	Google Sketchup	TRNSYS3D drawing file (*.idf)
TRNSYS Studio Project	Main simulation interface for project	TRNSYS Simulation Studio	TRNSYS Project file (*.tpf)
Multizone Building (Type 56)	Visual interface for specifying building inputs	TRNBuild	Building description file (*.b17)
TRNSYS Simulation Input file	Contains all details from the project, including inputs and parameters of all 'types' as an input to the model simulation	TRNEdit	TRNSYS Input File (.dck)
Model Simulation Run	The model is run through the TRNSYS Executable, which calls the TRNSYS Input file	TRNExe	Outputs as described in the project, with results displayed in online plotter, or saved to file as specified
MATLAB Model Simulation Control	Building parameters are selected in order to run varying simulations	MATLAB	Results file (*.csv) saved for each simulation listing internal temperatures and heat demand in each zone for each time step. Total heat energy demand for simulation period saved to cumulative results file (Results_writing.csv)

### 5.2.2 Description of model house and parameters

For the comparison of EEMs for a range of occupancy types, a typical UK house is identified. According to the English Housing survey 2012 (DCLG 2012), the most common dwelling is a semi-detached house (aka twin/duplex in which two entirely separate houses are adjoined on one side), accounting for around a quarter of dwelling types in the UK, with an average floor area of 93 m<sup>2</sup>. The geometry of the house used in the model is shown in Figure 5-2. The division of rooms in Figure 5-2 is based on realistic house proportions with insight gained by the author from floor plans for similar houses available online from estate agent websites.

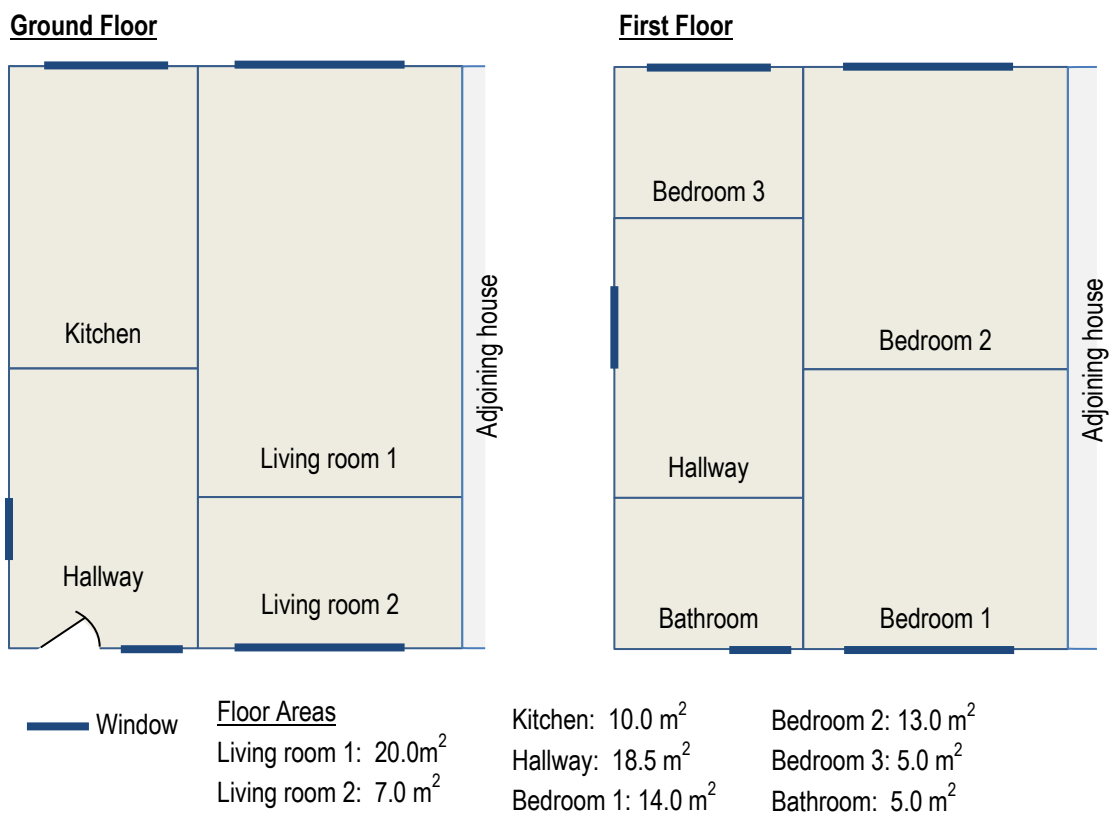


Figure 5-2 Plan of modelled house

The process for including each EEM within the building model is presented in section 5.4, including data selection for the input parameters. For other model parameters, data are based on typical values as found in literature or UK government statistics. These are listed in Table 5-2.

*Table 5-2 Description of modelling variables with justifications for chosen values*

<b>Modelling aspect</b>	<b>Value</b>	<b>Justification</b>
<b>House type</b>	Semi-detached (aka twin/duplex) house	Accounts for around a quarter of houses (DCLG 2012)
<b>House construction</b>	Solid wall construction	Represents around a quarter of UK homes, and those in greatest need of energy efficiency improvements
<b>Floor area</b>	92.5 m <sup>2</sup>	Typical three bedroom semi-detached house
<b>Glazed wall area</b>	Approximately 20 % of the internal floor area of each room (10 % for bathroom)	In line with current planning guidance (GLA 2012)
<b>Weather data</b> (external temperature, humidity and solar radiation)	Meteonorm file for 'London, UK'	Representative of a typical meteorological year for the UK
<b>Heating season</b>	1 <sup>st</sup> October – 30 <sup>th</sup> April	Typical for the UK and suitable for the weather file used
<b>Boundary temperature (for adjoined house)</b>	Identical	Represents the adjoining house being at the same temperature therefore there is no heat transfer
<b>Ground temperature</b>	10 °C	A simplified ground floor heat loss model is adopted whereby heat transfer through the ground is driven by a ground temperature equal to the average annual air temperature (CIBSE 2006a)
<b>Infiltration rate</b>	Constant value of 0.75 air changes per hour (ach)	Representative of typical leaky house
<b>Ventilation rate</b>	-	Infiltration rate is above the recommended minimum value of 0.5 ach (EST 2006; Jaggs & Scivyer 2009), therefore further sources of ventilation are not included
<b>Internal heat gains</b>	-	As a simplification, no internal heat gains have been added into the model; these could be included to simulate aspects of occupancy beyond occupancy pattern such as cooking practices and appliance use. Although heat gains will affect heat demand calculations, by treating all model scenarios the same, the effect of this omission is not expected to affect the comparisons of variations in energy consumption and energy savings from EEMs and occupancy patterns.
<b>Maximum heat input</b>	2 kW in each room	Typical radiator power
<b>Thermal capacity</b>	Twice room volume (J/m <sup>3</sup> K)	Approximation based on typical room contents
<b>Floor plan</b>	As in Figure 5-2	Insight gained from available floor plans of similar homes

### 5.3. Service demand

Households are heterogeneous entities and their demand for the service of heating thermal comfort will vary depending on a wide variety of factors such as house occupancy, use of space and temperature demand. The demand for service in this chapter is dictated by the household's use of their house – what temperature they desired in each room of the house at all times of day.

Previous attempts in literature to categorise households have been discussed in section 2.3.4 and a similar approach will be followed in this chapter. In order to represent a demand for service in this chapter, three household occupancy types will be considered with distinct occupancy patterns. Following the review of occupancy pattern clusters and scenarios used in previous studies as presented in section 2.3.3.2 (Yao & Steemers 2005; Aerts et al. 2014; Guerra-Santin 2011; Motuziene & Vilutiene 2013; de Meester et al. 2013) and known typical UK working or life patterns, three occupancy patterns have been determined for use in this chapter's modelling.

- The first pattern is a working family (WF) whose members are absent during the day but with a regular pattern through the week and can be expected to represent 28 % of the population, including couples and single parents with children (ONS 2013a).
- The second pattern is that of a working couple (WC) who is absent from the house during the day and returns to the house in the evening at varying times through the week; this pattern may represent 28 % of the population (ONS 2013a).
- The final pattern is that of a couple of which one or both remain in the house throughout the majority of the day; this has typically been attributed to a 'retired couple'. However, in recognition that many people remain very active in their retirement, and that there are a range of other reasons for people remaining at home during the day (such as those working from home, those who are jobless and those who are house bound due to disability), this pattern is referred to as daytime-present couple (DPC). A day-time present couple could represent 29 % of the population when including households over 75 (ONS 2013b) and home workers (ONS 2014).

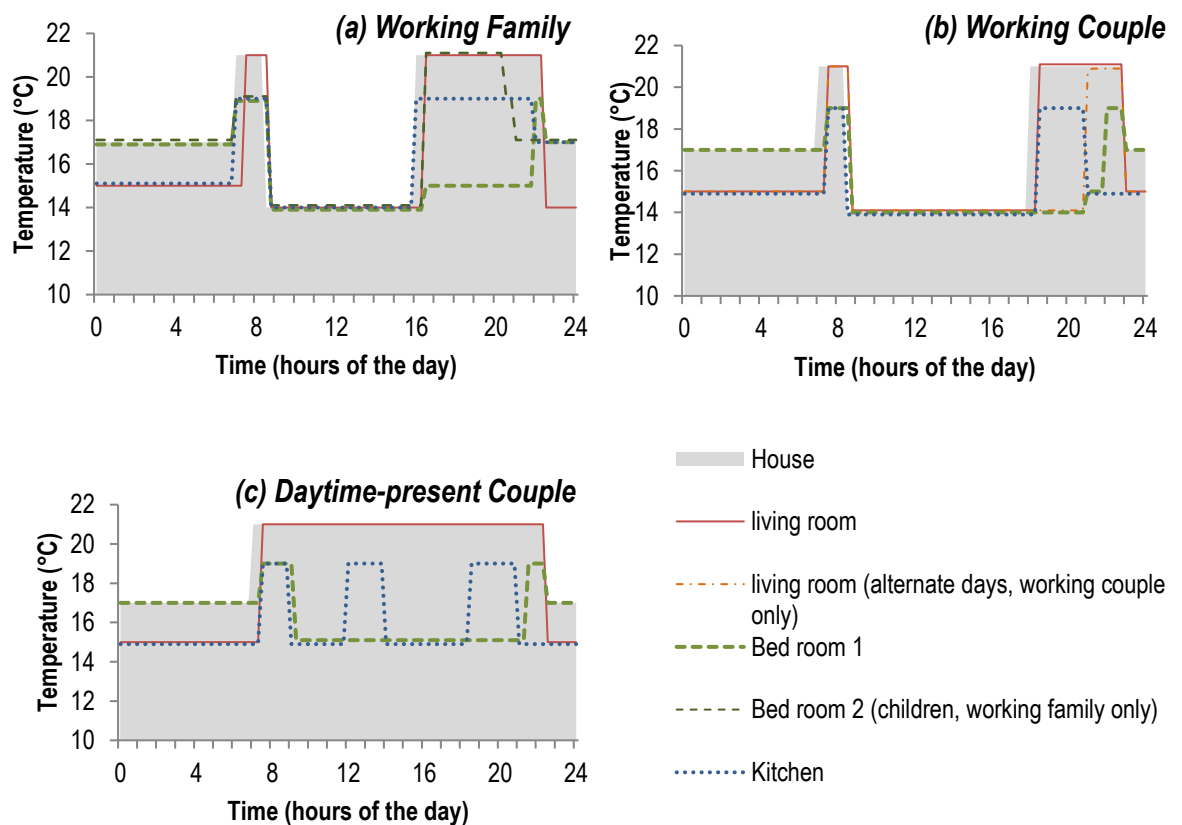
These occupancy profiles are further described in Table 5-3 and displayed in Figure 5-3. Temperature profiles are based on values derived from literature as presented in Table 5-9



(section 5.4.2.4). The same temperature set-points will be used for all three occupancy types.

*Table 5-3 Description of occupancy patterns used in modelling*

Occupancy pattern	Description
<b>Working Family</b>	House occupied by family (2 adults who work externally and 2 children). All occupants are absent 08.30-16.00. When the family is home, all areas of the house are usually occupied.
<b>Working Couple</b>	House occupied by couple (2 adults) who work externally during the day. All occupants are absent during the day, and sometimes in the evenings: four days per week 08.30-18.00, three days per week 08.30-21.00. When the couple is home, the house is partially occupied with one bedroom and one living room often not being used.
<b>Daytime-present Couple</b>	House occupied by couple (2 adults), one or both of whom are usually home during the day. The house is usually only partially occupied, with one bedroom and one living space often not being used.



*Figure 5-3 Ideal temperature profiles in different rooms for each of the three occupancy patterns. Shaded area shows baseline heating control using programmable timer thermostat (some temperature profiles have been off-set for greater visual clarity)*

## 5.4. Technologies and EEMs

### 5.4.1 Technology selection and modelling of energy efficiency measures

From the technologies in Table 2-6, a shortlist has been selected for the purpose of incorporating these different service delivery options into building modelling. The selected technologies are given in Table 5-4 and explained in more detailed below.

*Table 5-4 Shortlist of technologies for consideration within project*

Energy Efficiency measure type		Energy Efficiency measure
<b>A</b>	<b>Conversion device</b>	Boiler upgrade
<b>B</b>	<b>Passive system</b>	Solid wall Insulation
<b>C</b>		Loft Insulation
<b>D</b>	<b>Service delivery</b>	Use of Thermostatic radiator valves (TRVs)
<b>E</b>		Advance heating controls
<b>F</b>	<b>Service level</b>	Reducing internal temperature by 1°C
<b>G</b>		Partial under-heating of house

### 5.4.2 Modelling of energy efficiency measures

In order to compare energy savings attained through the implementation of EEMs, two further steps are needed: each measure identified in Table 5-4 must be incorporated into the building model, and realistic values must be identified for before and after the implementation of each measure. The inclusion of each EEM in the TRNSYS building model is achieved by translating the physical aspects of each measure into model inputs. For the identification of building parameters before and after the introduction of each EEM, data of realistic and typical values are collected from academic and industrial literature. A broad range of parameter values are modelled in order to demonstrate the sensitivity of the model results to the chosen data (the levels of other model parameters are included in Table. B-4 in B.2); the calculated value of savings will depend on both the initial and improved level of each parameter. This literature review and modelling will inform the values chosen for implementation in the following stage of modelling, allowing for the comparison of calculated savings between EEMs.

#### 5.4.2.1 Conversion device: high efficiency condensing boiler

Boiler efficiency is represented in the model as a constant factor within each simulation. For the purpose of modelling, an idealised heating system is represented in which final

energy input for heating is calculated directly from calculated heat demand. The calculated heat demand is assumed to be delivered to the house through radiators, and heat is directly replaced in the central heating fluid from the burning of gas. The boiler is represented by a TRNSYS "equation component" which multiplies the total heat demand in each zone by the efficiency of the boiler and thus calculates the chemical energy in the gas. A typical efficiency of a conventional non-condensing boiler is 70 %, and this value will be used to represent initial boiler efficiency. Although new A-rated condensing boilers have a reported efficiency of over 90 %, in reality, the efficiency of boilers used in homes do not achieve these standards, and an average in-use efficiency of a domestic A-rated condensing boiler was found by Orr et al. (2009) to be 85.6 %. A boiler efficiency of 86 % will therefore be used following a boiler upgrade intervention.

#### 5.4.2.2 *Passive system: insulation of walls and roof*

The standard U-value used for an un-insulated solid wall in the majority of building models (as calculated based on equation (4-6)) is 2.1 W/(m<sup>2</sup>K) (CIBSE 2006a; Anderson et al. 1985). However, published research on a number of empirical trials has shown this value to commonly be lower (higher thermal resistance) with measured values between 0.5 and 2.0 W/(m<sup>2</sup>K) (Stevens & Bradford 2013; Baker 2011; Rye & Scott 2012; Li et al. 2015). Hence, a U-value of 1.4 W/(m<sup>2</sup>K) will be used for modelling the thermal behaviour of uninsulated solid brick walls, as was found to be the median value in a field study by the UK's Energy Saving Trust (EST) (Stevens & Bradford 2013). For an insulated wall, building regulation standards specify that all walls, regardless of whether they are solid or cavity construction, should have a maximum U-value of 0.3 W/(m<sup>2</sup>K). However, this standard is difficult to achieve for solid wall construction and the same field study found an average U-value for solid walls with insulation of 0.44 W/(m<sup>2</sup>K) (Stevens & Bradford 2013).

For the roof, national studies estimate that less than 1 % of UK houses have no roof insulation at all (DECC 2013b) and that a minimum thickness of 0.03m of insulation can be assumed in most houses. Improved insulation is implemented as 0.25 m thickness of mineral wool insulation, typically assigned to the horizontal base of the unheated roof space between the joists, as opposed to on the pitched sides of the roof under the tiles. This thickness of insulation is in accordance with building standards, dictating a maximum U-value of 0.16 W/(m<sup>2</sup>K).

Windows can be the building element with the greatest heat loss, with traditional single glazed windows having a typical U-value of 5.75 W/(m<sup>2</sup>K). Prior to the 1980s most houses were initially built with single glazed windows. With the rapid growth of the double glazing industry in 1980s and 90s, double glazing became standard in new houses

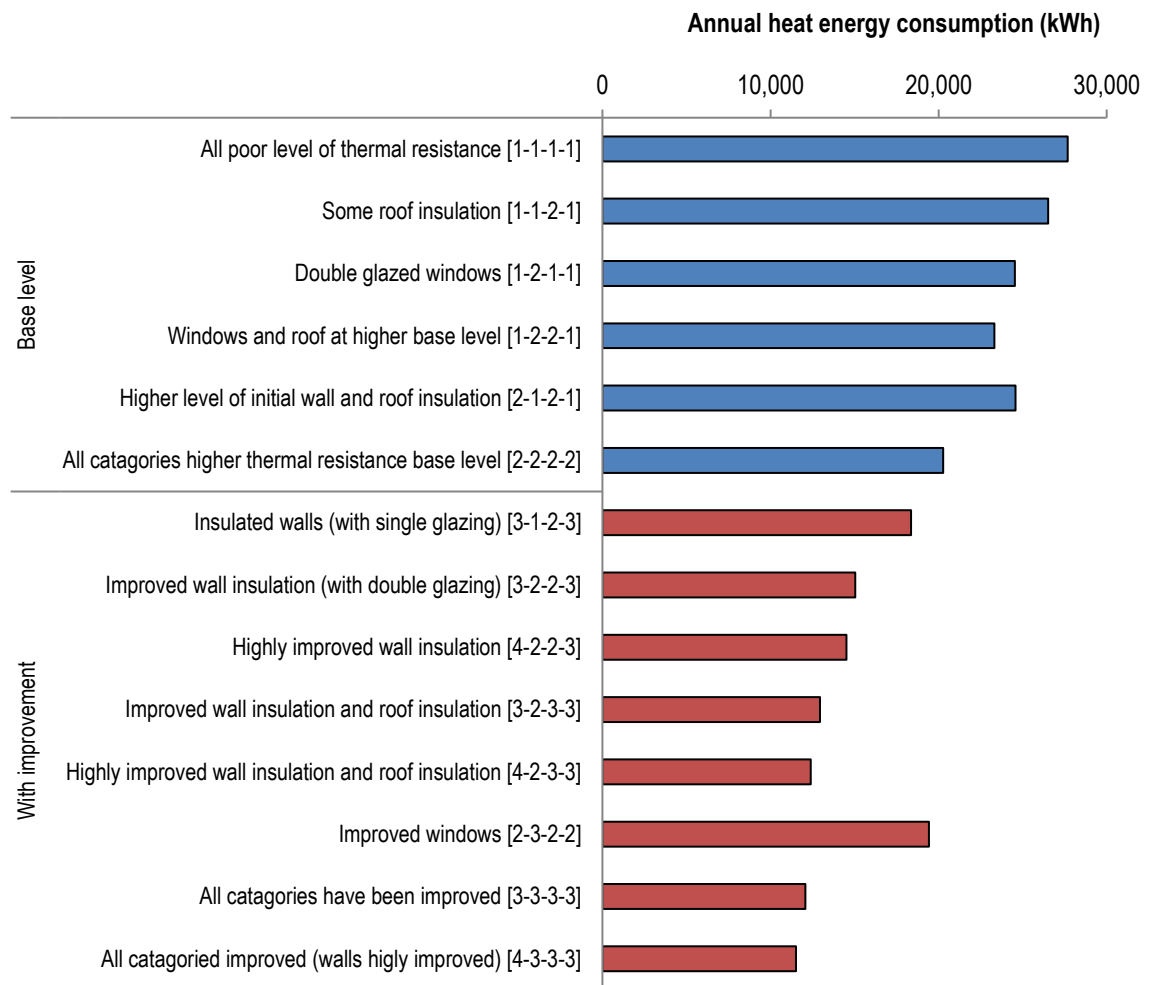
(being stipulated in building regulations since 2006), as did the replacement of conventional single glazing in pre-existing houses. Double glazing enables windows to be manufactured with U-value between 2 and 3 W/(m<sup>2</sup>K), depending on the thickness of the air gap and the emissivity of the glass (CIBSE 2006a). The proportion of homes with double glazing has grown from 51 % in 2001 to 79 % in 2012 (DCLG 2014). Beyond double glazing, high performance triple glazed windows are also available, exhibiting a U-value as low as 1.8 W/(m<sup>2</sup>K), however the uptake of triple glazing is quite low.

The range U-values of walls, windows and roof are presented in Table 5-5 and these represent a scale from 'poor' thermal resistance (ascribed as level 1) to 'good' or 'very good' (ascribed a level 3 or 4 respectively). A number of realistic combinations of thermal resistance of walls, roof and windows have been calculated and are shown in Figure 5-4. These options show the possible state of the house prior to and after intervention (upper and lower section of graph respectively). In all cases, the infiltration rate is also matched to the quality of the building envelope, ranging from a 'poor' standard of 1.0 air change per hour (ach), 'typical' standard of 0.75 ach and 'good' standard of 0.5 ach.

*Table 5-5 Explanation of level of thermal resistance for building elements used in model calculations for Figure 5-4*

Thermal resistance level	Walls	Windows	Roof
<b>Poor</b> 1	Value of U-value for solid wall with no thermal insulation, typically used by CIBSE <sup>1</sup> U-value = 2.1 W/m <sup>2</sup> K	Double glazed windows U-value = 2.1 W/m <sup>2</sup> K	No thermal insulation U-value = 2.1 W/m <sup>2</sup> K
<b>Typical</b> 2	Average reported measured value for un-insulated solid wall U-value = 1.4 W/m <sup>2</sup> K	Double glazed windows U-value = 2.1 W/m <sup>2</sup> K	Small amount of thermal insulation (found in 98 % of houses) U-value = 1.0 W/m <sup>2</sup> K
<b>Good</b> 3	Average reported measured value for insulated solid wall U-value = 0.44 W/m <sup>2</sup> K	High performance triple glazed windows U-value = 1.8 W/m <sup>2</sup> K	Insulation standard of 0.25 m thickness of insulation U-value = 2.1 W/m <sup>2</sup> K
<b>Very good</b> 4	Building standards level for improved solid wall insulation U-value = 0.3 W/m <sup>2</sup> K		

<sup>1</sup> CIBSE: Chartered Institute of Building Service Engineers. A U-value of 2.1 W/m<sup>2</sup>K is typically used in SAP (Standard Assessment Procedure) calculations



*Figure 5-4* Calculated values of heating energy demand for a range of base level thermal resistance and improvements. Numbers in square brackets refer to indication of thermal resistance level in Table 5-5, corresponding to wall, window, roof and infiltration standard

The range of values of heating energy consumption before and after intervention demonstrate the wide range of values of savings which could be calculated depending on which assumptions are made for the parameter values selected for the initial state of the building envelope thermal resistance.

For comparison of modelled values against typical values, more in-depth validation is undertaken in section 5.6. Measured gas consumption values for a similar three bedroom property span a range of 21,400 kWh/yr (upper quartile for a pre-1919 house) to 9,000 kWh/yr (lower quartile of house build post 1999) (DECC 2014c). The modelled values range from 11,500 kWh/yr to 27,680 kWh/yr is therefore the right order of magnitude, but values are towards the upper end (especially once a conversion from heat demand to gas consumption is applied as is given greater consideration in section 5.6).

For the purpose of modelling in this project, the level of thermal resistance of each building element will be based on values measured in empirical studies (quoted in literature) rather than the commonly assumed values and building standards. Therefore, for the thermal

transmittance of a solid wall, an un-insulated wall is ascribed a U-value of 1.40 W/(m<sup>2</sup>K) and an insulated wall is given a U-value of 0.44 W/(m<sup>2</sup>K). For the roof, a base level prior to additional insulation is given a U-value of 1.00 W/(m<sup>2</sup>K). For the simulation of additional insulation, a U-value of 0.16 W/(m<sup>2</sup>K) is used due to a general consensus in the literature and since insulating between rafters in the roof space is more straightforward than other types of insulation. The modelled U-value reductions represent improvements from 'typical' [level 2] to 'good' [level 3] (in reference to Table 5-5). Windows will be double glazed throughout (representing a standard of 'typical' [level 2]).

The construction of other building elements which are not being investigated are taken from standard building constructions in CIBSE guide A (CIBSE 2006a). All building envelope construction elements are described in Table 5-6.

*Table 5-6 Wall, roof and window construction used in model*

<b>Building element</b>	<b>Thermal resistance level</b>	<b>Material</b>	<b>Thickness (m)</b>	<b>U-value (W/(m<sup>2</sup>K))</b>
<b>Wall (Solid wall construction)</b>	Pre-insulation (empirical U-value)	Brick Plaster	0.360 0.045	1.40
	Typical insulated (internal wall insulation)	Brick Insulation (mineral wool) Plasterboard	0.360 0.065 0.020	0.44
<b>Internal walls</b>	Typical construction	Plaster Brick Plaster	0.013 0.215 0.013	1.52
<b>Boundary walls</b>	Typical construction	Plasterboard Brick Plasterboard	0.012 0.220 0.012	1.40
<b>Roof (horizontal base of roof space)</b>	Pre-insulation (empirical U-value)	Insulation (Mineral wool) Plasterboard	0.032 0.012	1.00
	Typical insulated	Insulation (Mineral wool) Plasterboard	0.250 0.012	0.16
<b>Roof tiles</b>	Typical construction	Tiles	0.02	5.26
<b>Windows</b>	Double glazed			2.83
<b>Ground Floor (solid)</b>	Typical construction	Plywood	0.010	0.86
		Concrete	0.100	

### *5.4.2.3 Service control: TRVs and advanced heating controls*

In the case of home heating, the way in which the input of final energy is controlled can enable the service of thermal comfort to be delivered more efficiently by reducing waste. If a room is heated whilst unoccupied, no service is being delivered and therefore energy is consumed for no delivered benefit. Conversely, good control can pre-empt the beginning of an occupied period and therefore ensure that the service is being sufficiently delivered as soon as it is required.

Central heating is most commonly controlled using a combination of wall thermostat, programmable timer and thermostatic radiator valves (TRVs) (Munton et al. 2014). A wall thermostat is typically situated in the main living room or hallway to turn the heating system on and off as internal ambient temperature rises and falls. A programmable timer enables a household to control the schedule of heating throughout the day, including setting heating to switch on before the house is occupied to allow for a warm-up period. TRVs allow temperature set-points to be varied between rooms in the house by use of a thermo-responsive valve controlling the flow of water through each radiator. Beyond these common controls, the innovation in wireless control and the availability of more powerful batteries have led manufacturers to develop advanced heating controls that allow space heating to be regulated in individual rooms (Beizaee et al. 2015). Advanced zonal heating controls (AZHCs) make it possible for the set point temperature of rooms to be adjusted on different time-schedules based on a household's occupancy patterns. AZHCs also have the capability to be controlled remotely, for instance from a computer or smart phone, giving a household flexibility to change the heating times daily around their personal agenda. The ownership of heating controls allow for different heating management options as shown in Table 5-7.

*Table 5-7 Heating management options enabled by heating controls*

Heating management option	Heating controls			
	House thermostat	Heating timer	Thermostatic Radiator Valves (TRVs)	Advanced control – individual room thermostats
<i>Timing of heating controlled by pre-set schedule, no individual temperature control in rooms</i>	X	X		
<i>Timing of heating controlled by pre-set schedule, rooms set at constant varied temperature</i>	X	X	X	
<i>Heating controlled in each room individually by time and temperature set-point</i>				X

The method of heating control is replicated within the building model through temperature set-point schedules. Heating set-point temperature schedules are created for the present work based on data gained for typical occupancy profiles and typical temperatures of internal zones at different times of day, taken from empirical studies in literature and covered in more detail in section 2.3.3. Six varied heating options have been created based on the availability and use of different types of heating controls. These heating options are detailed in Table 5-8.

Table 5-8 Examples of heating schedules for different heating control options - illustrative

Heat Control Option	Description	Example of schedule <sup>1</sup>							
<b>1: House thermostat</b>	Temperature maintained at same temperature throughout day	All rooms	<b>H:</b> 0.00	24.00					
			<b>T:</b> $T_{oh}$	$T_{oh}$					
<b>2: House On-off</b>	Temperature controlled for whole house by switching heating on when in the house and off when out of the house. Includes house thermostat	All rooms	<b>H:</b> 0.00	07.30	08.30	18.30	23.00	24.00	
			<b>T:</b> $T_{of}$	$T_{oh}$	$T_{of}$	$T_{oh}$	$T_{of}$	$T_{of}$	
<b>3: House On-off with TRVs</b>	As for 2, with TRVs in each room such that maximum temperature for each room can be determined	Each room	<b>H:</b> 0.00	07.30	08.30	18.30	23.00	24.00	
			<b>T:</b> $T_{of}$	$T_{or,i}$	$T_{of}$	$T_{or,i}$	$T_{of}$	$T_{of}$	
<b>4: House timer control</b>	Temperature controlled for whole house by programmable timer thermostat, allowing different set-point temperature through day	All rooms	<b>H:</b> 0.00	07.00	08.30	18.00	23.00	24.00	
			<b>T:</b> $T_{n,h}$	$T_{oh}$	$T_{uo}$	$T_{oh}$	$T_{n,h}$	$T_{n,h}$	
<b>5: House timer control with TRVs</b>	As for 5, with TRVs in each room such that maximum temperature for each room can be determined	Each room	<b>H:</b> 0.00	07.00	08.30	18.00	23.00	24.00	
			<b>T:</b> $T_{n,h}$	$T_{or,i}$	$T_{uo}$	$T_{or,i}$	$T_{n,h}$	$T_{n,h}$	
<b>6: Zonal thermostat control</b>	Advanced heating controls which allow for different temperatures to be set in different rooms of the house at different schedules and for heating to be controlled from outside of the house	Living room 1 and 2	<b>H:</b> 0.00	07.00	08.30	18.00	23.00	24.00	
			<b>T:</b> $T_{vr}$	$T_{or,i}$	$T_{uo}$	$T_{or,i}$	$T_{vr}$	$T_{vr}$	
		Kitchen	<b>H:</b> 0.00	07.00	08.30	18.00	21.00	24.00	
			<b>T:</b> $T_{vr}$	$T_{or,i}$	$T_{uo}$	$T_{or,i}$	$T_{vr}$	$T_{vr}$	
		Bedrooms 1 and 2	<b>H:</b> 0.00	07.00	08.30	22.00	23.00	24.00	
			<b>T:</b> $T_{n,i}$	$T_{or,i}$	$T_{uo}$	$T_{or,i}$	$T_{n,i}$	$T_{n,i}$	
		Hallway	<b>H:</b> 0.00	07.00	08.30	18.00	23.00	24.00	
			<b>T:</b> $T_{vr}$	$T_{or,i}$	$T_{uo}$	$T_{or,i}$	$T_{vr}$	$T_{vr}$	

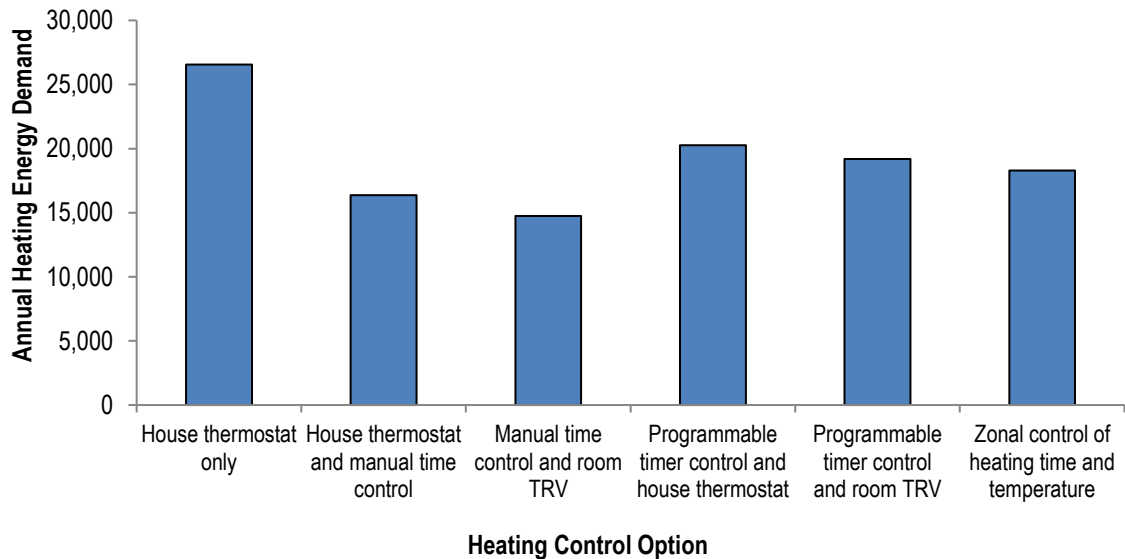
<sup>1</sup> for occupant couple waking at 07.30, leaving house at 08.30, returning from work at 18.30, going to bed at 23.00 [H: Hour, T: Temperature set-point]

**Temperature Key:**  $T_{oh}$  is temperature set-point of the whole house when house is occupied;  $T_{oh,i}$  is temperature set-point of room  $i$  whilst house is occupied (via TRV);  $T_{or,i}$  is temperature set-point of room  $i$  whilst room is occupied (via AZHC);  $T_{of}$  is temperature set-point when the heating is off (for model purpose);  $T_{uo}$  is temperature set-point when the house is un-occupied;  $T_{nh}$  is night time temperature set-point of the house;  $T_{n,i}$  is night time temperature set-point of room  $i$ ;  $T_{vr}$  is set-point temperature of an un-occupied (vacant) room, chosen to be under-heated

Heating energy demand is calculated for the full range of heating control options exhibited in Table 5-8, and these are presented in Figure 5-5. The calculated energy demand for the most basic control of a single house thermostat is over 30 % higher than any other option, demonstrating the savings achievable for some form of timing control. Manual timing control shows a significantly lower energy demand than programmable timing control demonstrating that technology adoption does not always result in energy savings, but may



result in a better delivery of the demanded service (as will be further considered in Chapter 6). The use of TRVs allows different set-point temperatures to be implemented throughout the house, which are calculated to deliver an 11 % and 6 % saving for manual timing control and programmable timing control respectively. The variation in heating energy demand calculated for the range of heating control types reveals the importance of choosing an appropriate base line situation for modelling when energy savings are to be calculated.



*Figure 5-5 Annual heating energy demand calculated for range of heating control options (based on a working family occupancy pattern)*

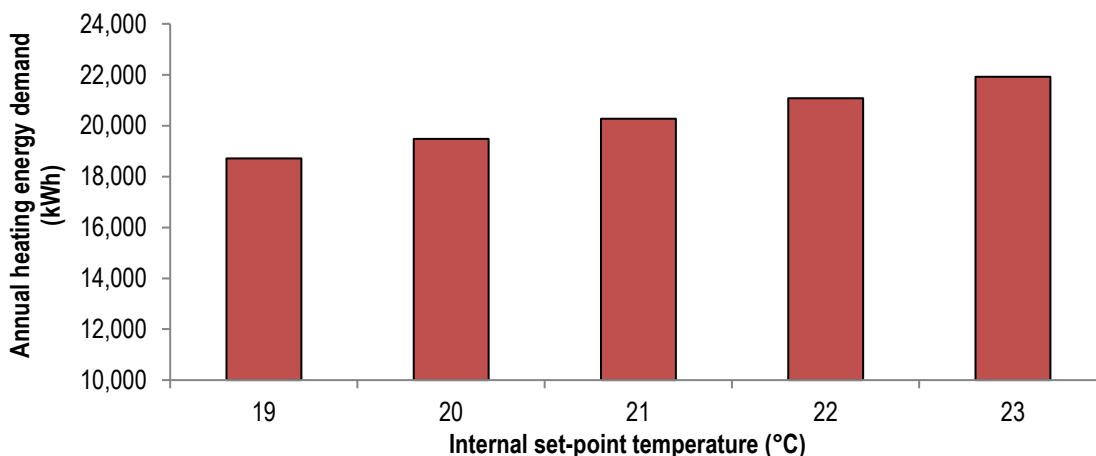
Based on a survey of the existing UK landscape of heating controls (Munton et al. 2014), the initial case for heating controls in the present model is to be a room thermostat and a heating timer. The heating can thus be set to turn on half an hour before an occupancy period and off at the end of it, but set-point temperature is the same throughout the whole house. The same pattern is used throughout the week as studies have shown little difference between the temperature profiles of homes on weekdays and weekends (Huebner, McMichael, et al. 2015; Kane 2013).

A first improvement for service control is the use of TRVs in order to provide an appropriate temperature in each room. The TRV allows temperature setting on a sliding scale, typically 0-5; calibration of TRV setting to temperature varies by model, but typically enables temperature control between 12 °C and 23 °C. A second level of improvement is the introduction of AZHCs with the ability to set different temperatures profile for each room, and to control the heating remotely.

#### 5.4.2.4 *Service level: reduced internal temperature and reduced heated floor area*

Behaviour change interventions have been found to offer significant potential for energy savings. Although the presence of technologies can enable and support behaviour change, the main requirement for implementation is the choice of the occupants. Social theories have proposed that choices and habits associated with home heating are beyond the rational choice of occupants, but for the purpose of this study, it is thought to be beneficial to demonstrate whether a choice to reduce service level can have equivalent energy savings to other technology focussed interventions. The level of service in this chapter has been defined according to two factors; desired internal temperature and floor area of the heated space.

Turning the thermostat down one degree has for a long time been a key message in energy saving behaviour advice. The temperature which homes are heated to may be controlled by a thermostat or by the occupants' perception of warmth. Comfortable temperature is subjective and varies with individuals. Social expectations for household temperatures have changed over time; the temperature of the UK living room has increased in the past decades, suggesting that comfortable temperature can be considered as being flexible (Shove 2003a). Temperature reductions can commonly be endured through additional adaptive behaviour such as increasing clothing. The addition of a thick sweater (0.3 clo of insulation) has been estimated to reduce the required air temperature by around 1 °C (Hunt & Gidmant 1982) or by a range from 0.5 to 2 °C (Palmer et al. 2012). For the investigation of different levels of service demand, a range of internal temperatures from 19 °C to 23 °C have been modelled and are shown in Figure 5-6. The linear relationship between calculated heating energy demand and internal temperature set-point shows that energy savings are directly proportional to a chosen internal temperature reduction (as also shown in section 4.5.3).



*Figure 5-6 Annual heating energy demand calculated for range of internal temperature set-points*

With reference to the work by Shipworth et al. (2010), the initial temperature set-point is chosen as 21 °C in the living room with the inclusion of heating controls allowing slight variation between rooms as shown in Table 5-9. Temperatures in other rooms around the home were varied based on assumed typical temperature settings related to recommended best practice; to set TRVs lower in bedrooms and rooms used less often (EST 2013). Some studies which have investigated temperature behaviours have focussed on bedrooms as well as living rooms, typically showing that bedrooms are heated to a lower temperature than living rooms (Hong et al. 2009; Kane 2013; Kelly 2013; Beizaee et al. 2015). However, there is a lack of similar studies which investigate temperatures in other rooms of the house, and such empirical work would be of benefit to modelling work such as that presented in this thesis.

*Table 5-9 Temperature set-points used for heating control profiles in building model (as referred to in Table 5-8 and Table 5-11)*

Symbol	Description	Temperature (°C) (or TRV setting)
$T_{oh}$	Temperature set-point of the whole house when house is occupied	21
$T_{oh,i}$	Temperature set-point of room $i$ whilst house is occupied (via TRV);	Living room: 21 (TRV: 4) Kitchen: 19 (TRV: 3) Bedroom: 19 (TRV: 3)
$T_{or,i}$	Temperature set-point of room $i$ whilst room is occupied (via AZHC);	Bathroom: 21 (TRV: 4) Hallway: 19 (TRV: 3)
$T_{of}$	Temperature set-point when the heating is off (for model purpose);	12
$T_{uo}$	Temperature set-point when the house is un-occupied;	14
$T_{nh}$	Night time temperature set-point of the house;	17
$T_{n,i}$	Night time temperature set-point of room $i$ ;	Living room: 15 Kitchen: 15 Bedroom: 17 Bathroom: 17 Hallway: 15
$T_{vr}$	Set-point temp of an un-occupied (vacant) room, chosen to be under-heated	15

For the implementation of the EEM, temperature reductions of 1 and 2 °C are to be investigated (and the temperature set-points thus used are detailed in Table 5-10).

*Table 5-10 Temperature set-points throughout house used in initial case and for one or two degree temperature reduction*

Room or Zone	Set-point temperatures ( °C )		
	Initial	1°C reduction	2°C reduction
<b>Indicative internal temperature</b>	21	20	19
<b>House thermostat<sup>1</sup></b>	21	20	19
<b>Living room</b>	21	20	19
<b>Kitchen</b>	19	18	17
<b>Bedroom<sup>2</sup></b>	19	18	17
<b>Bathroom</b>	21	20	19
<b>Hall</b>	19	18	17
<b>Night time</b>	17	16	15
<b>Low temperature set-point when heating off</b>	12	12	12
<b>Low temperature set-point when room unoccupied</b>	15	15	15
<b>Low temperature set-point when house unoccupied</b>	14	14	14

<sup>1</sup> In initial heating scenarios of programmable timer, all rooms are set at this value of house thermostat

<sup>2</sup> This temperature is used for bedroom during waking hours in zonal heating scenarios, but drops to night time temperature during sleeping hours

Partial heating of a house has become less prevalent in the UK with the wide uptake of central heating. The existence of partial house heating may remain unavoidable due to the pressures of fuel poverty, but in other cases it is chosen due to changes in occupancy of a house and rooms becoming surplus. As household characteristics change, for instance with children growing up and moving out, parts of the house cease to be occupied for large periods of time and could be left unheated (or under-heated) for these long periods. Alternatively, if occupancy is lower than maximum at times during the day, such as for one person working from home, parts of the house can be unheated at certain times of the day only, especially with appropriate heating control.

The choice of partial under-heating has been represented in the model as no heating or less heating in un-occupied rooms. These unoccupied rooms are identified as the secondary living room and bedrooms 2 and 3 in households which have fewer than 4 people (working couple and day-time present couple). The method for partial under-heating depends on the technology which has been installed. For no individual room temperature control, under-heated rooms have no heat input (representing radiator flow being manually shut-off). Following the introduction of TRVs, under-heated rooms can have a low temperature set-point, represented by a low TRV setting. With the inclusion of zonal heating control, a similar low heating set point can be employed in those rooms which are unoccupied, with the option of having short periods throughout the day during which the rooms are occupied and heated (such as the secondary living room during the evening). Table 5-11 presents the

heating profiles used in the building model to represent the choice of partial under-heating for different control options.

**Table 5-11** Examples of heating schedules for different partial under-heating control options – illustrative. These form a continuation from heating control options as given in Table 5-8.

Heat Control Option	Description	Example of schedule <sup>1</sup>						
<b>7: House On-off with TRV and partial under-heating</b>	As for 3 in Table 5-8, with TRV level set to lowest in un-used spaces (secondary living room and second bedroom)	Living room 1, Kitchen, Bedroom 1, Hallway	<b>H:</b> 0.00	07.30	08.30	18.30	23.00	24.00
			<b>T:</b> $T_{of}$	$T_{or,i}$	$T_{of}$	$T_{or,i}$	$T_{of}$	$T_{of}$
		Living room 2, Bedroom 2, 3	<b>H:</b> 0.00	07.30	08.30	18.30	23.00	24.00
			<b>T:</b> $T_{of}$	$T_{vr}$	$T_{of}$	$T_{vr}$	$T_{of}$	$T_{of}$
<b>8: House timer control with TRV and partial under-heating</b>	As for 6 in Table 5-8, with TRV level set to lowest in un-used spaces (secondary living room and second bedroom)	Living room 1, Kitchen, Bedroom 1, Hallway	<b>H:</b> 0.00	07.00	08.30	18.00	23.00	24.00
			<b>T:</b> $T_{nh}$	$T_{or,i}$	$T_{uo}$	$T_{or,i}$	$T_{nh}$	$T_{nh}$
		Living room 2, Bedroom 2, 3	<b>H:</b> 0.00	07.00	08.30	18.00	23.00	24.00
			<b>T:</b> $T_{vr}$	$T_{vr}$	$T_{vr}$	$T_{vr}$	$T_{vr}$	$T_{vr}$
<b>9: Zonal thermostat control with partial under-heating</b>	As for 8 in Table 5-8, with temperature level set to low in un-used spaces (secondary living room and second bedroom)  Advanced heating controls which allow for different temperatures to be set in different rooms of the house at different schedules and for heating to be controlled from outside of the house	Living room 1	<b>H:</b> 0.00	07.00	08.30	18.00	23.00	24.00
			<b>T:</b> $T_{vr}$	$T_{or,i}$	$T_{uo}$	$T_{or,i}$	$T_{vr}$	$T_{vr}$
		Living room 2	<b>H:</b> 0.00	07.00	08.30	18.00	23.00	24.00
			<b>T:</b> $T_{vr}$	$T_{vr}$	$T_{vr}$	$T_{or,i}$	$T_{vr}$	$T_{vr}$
		Kitchen	<b>H:</b> 0.00	07.00	08.30	18.00	21.00	24.00
			<b>T:</b> $T_{vr}$	$T_{or,i}$	$T_{uo}$	$T_{or,i}$	$T_{vr}$	$T_{vr}$
		Bedrooms 1	<b>H:</b> 0.00	07.00	08.30	22.00	23.00	24.00
			<b>T:</b> $T_{n,i}$	$T_{or,i}$	$T_{uo}$	$T_{or,i}$	$T_{n,i}$	$T_{n,i}$
		Bedroom 2	<b>H:</b> 0.00	07.00	08.30	22.00	23.00	24.00
			<b>T:</b> $T_{vr}$	$T_{vr}$	$T_{vr}$	$T_{vr}$	$T_{vr}$	$T_{vr}$
		Hallway	<b>H:</b> 0.00	07.00	08.30	18.00	23.00	24.00
			<b>T:</b> $T_{vr}$	$T_{or,i}$	$T_{uo}$	$T_{or,i}$	$T_{vr}$	$T_{vr}$

<sup>1</sup>for occupant couple waking at 07.30, leaving house at 08.30, returning from work at 18.30, going to bed at 23.00

[H: Hour, T: Temperature set-point]. Temperature nomenclature is consistent with Table 5-8

### 5.4.3 Combinations of measures

In reality, households are not restricted to making single changes. For example, when considering insulation of the building shell it is unlikely that wall insulation would be completed in isolation; if the roof is not already well insulated, roof and wall insulation are a likely joint measure. If the availability of finance or threats of disruption are barriers to implementing certain EEMs, equivalent energy savings may be possible through combinations of low or no cost measures. Table 5-12 shows indicators of the barriers to the adoption of the EEMs, including cost, expertise required for installation and operation, and disruption caused by installation and use. Table 5-13 gives the full list of combined measures being considered alongside single measures. In Table 5-12, the conversion device

and passive system improvements show larger barriers with relation to installation and cost, and these are removed by the second third and fourth combination in Table 5-13.

*Table 5-12 Barriers to the adoption of EEMs and the level to which they apply*

<b>EEM</b>	<b>Expertise for installation</b>	<b>Expertise for operation</b>	<b>Financial cost</b>	<b>Disruption of installation</b>	<b>Inconvenience of operation</b>
<b>Boiler replacement</b>	●●●●●	●●000	●●●●0	●0000	●0000
<b>Insulation – roof</b>	●●●00	●0000	●●●00	●●●●●	●0000
<b>Insulation – wall</b>	●●●●●	●0000	●●●●●	●●●●●	●0000
<b>Temperature reduction</b>	●0000	●0000	00000	●0000	●●●00
<b>Partial heating</b>	●0000	●●000	●0000	●0000	●●●00
<b>Zonal heating control</b>	●●000	●●●●0	●●000	●0000	●●●●0

*Table 5-13 Outline of combinations of measures investigated in the present work*

<b>Combination of measures</b>	<b>Justification</b>
Roof and wall insulation	It is realistic to expect that wall insulation would be accompanied by roof insulation if this is not already in place and therefore it is appropriate to consider these as combined EEMs.
Heating controls (TRV or zonal control) <i>plus</i> Partial heating	Partial heating can be achieved more easily with the introduction of more advanced heating controls. In these cases, partial heating is simulated by a set temperature of 15 °C.
Heating controls (TRV or zonal control) <i>plus</i> 1 °C temperature reduction	Improved heating controls can allow for better controlling of the set-point temperature, and facilitate a temperature reduction.
Heating controls (TRV or zonal control) <i>plus</i> Partial heating <i>plus</i> 1 °C temperature reduction	Partial control and temperature reduction are behavioural EEMs and therefore have no financial cost and can be implemented alongside other measures.

## 5.5. Calculation of energy savings achievable with the implementation of EEMs

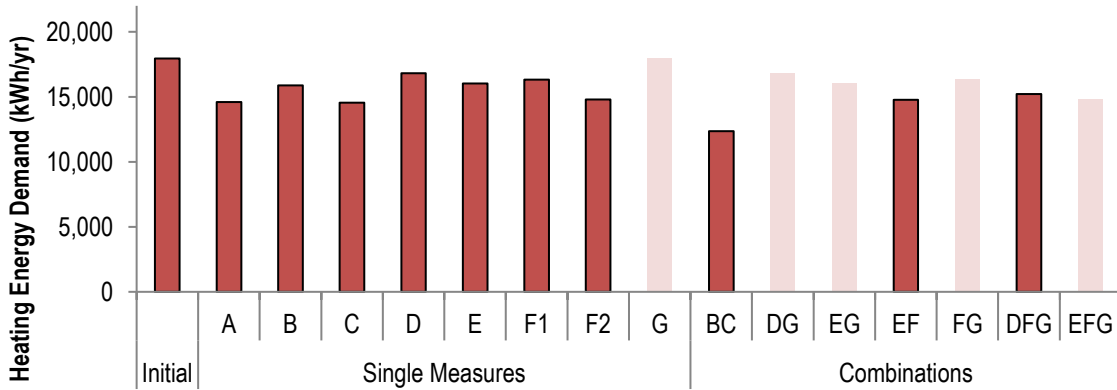
### 5.5.1 Comparison of EEMs in reducing energy demand

For the comparison of different EEM choices and combinations, the values for initial and improved levels of each EEM are presented in Table 5-14. These are implemented as single measures and in combination as shown in Table 5-15. The values of energy demand for heating over a 1 year period are compared in Figure 5-7.

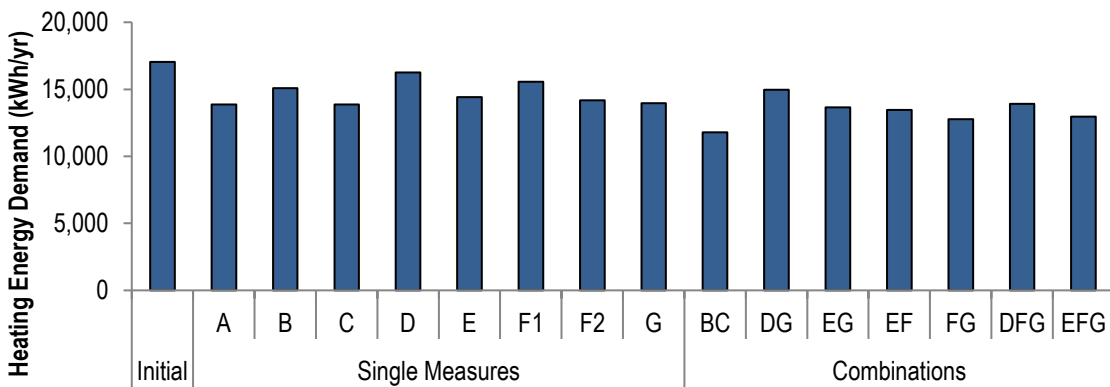
*Table 5-14 Values of energy efficiency measures for before and after the implementation of the intervention*

Energy Efficiency measure type		Energy Efficiency measure	Description	Before	After
<b>A</b>	<b>Conversion device</b>	Boiler upgrade	Energy efficiency of heating system improved	70 %	86 %
<b>B</b>	<b>Passive system</b>	Solid wall Insulation	Thermal transmittance (U-value) of solid walls / Roof improved	1.40 W/(m <sup>2</sup> K)	0.44 W/(m <sup>2</sup> K)
<b>C</b>		Roof Insulation		1.00 W/(m <sup>2</sup> K)	0.16 W/(m <sup>2</sup> K)
<b>D</b>	<b>Service control</b>	Use of Thermostatic radiator valves (TRVs)	Set-point temperature in rooms varied according to temperatures typically desired	All rooms heated to 21°C	Occupied temperature: Living room, Bathroom 21°C; Kitchen, Hallway 19°C, Bedroom 17 °C
<b>E</b>		Zonal heating controls	Alternative option for controlling temperature set point	Programmable thermostat controlling whole house	Individual programmed thermostats with control from outside the house
<b>F</b>	<b>Service level</b>	Reducing internal temperature	Internal temperature set point decreased throughout house	21 °C	1 °C reduction: 20 °C 2 °C reduction: 19 °C (see Table 5-10)
<b>G</b>		Partial under-heating of house	Unoccupied rooms to be unheated	All rooms heated	Secondary living space and bedrooms under-heated in working couple and daytime present couple scenarios

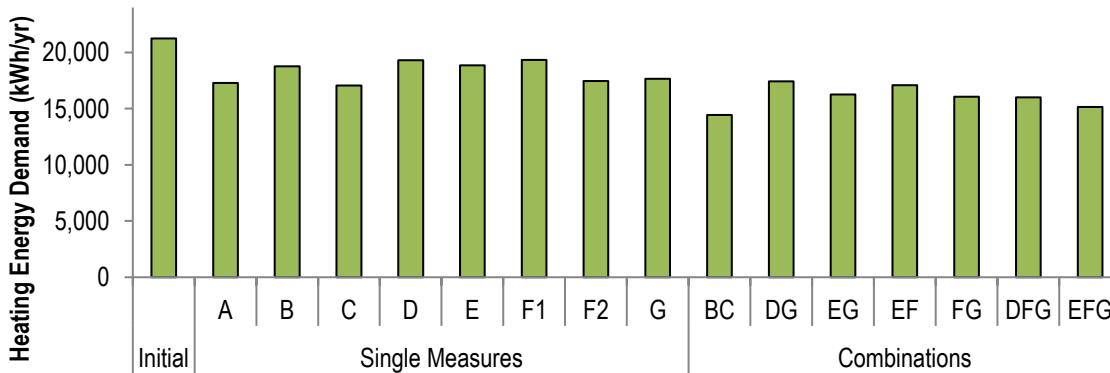
**(a) Working Family**



**(b) Working Couple**



**(c) Daytime-present Couple**



*Figure 5-7 Modelled values of energy demand for heating values for a range of single and combinations of energy efficiency measures. EEMs are given in Key in Table 5-15. Values are calculated for three occupancy patterns which represent (a) working family, (b) working couple, and (c) daytime-present couple. Shaded out bars in (a) are those which do not apply*



## 5.5. Calculation of energy savings achievable with the implementation of EEMs

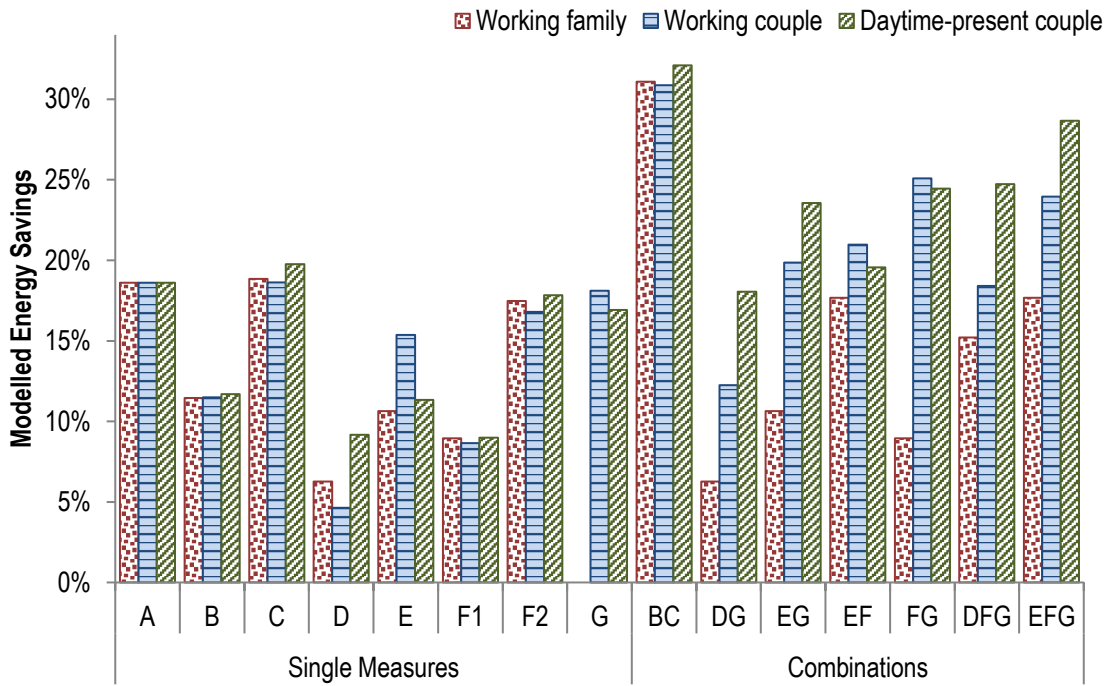
*Table 5-15 Key to EEMs (single and combinations) plotted in Figure 5-7 and Figure 5-8*

Energy Efficiency Measures	Conversion Device	Passive System		Service Control		Service Level		
	A: Boiler upgrade	B: Roof insulation	C: Wall insulation	D: TRVs	E: AZHCs	F: Temperature reduction	G: Partial under-heating	
<b>Single</b>	<i>Initial</i>							
	<b>A</b>							
	<b>B</b>							
	<b>C</b>							
	<b>D</b>							
	<b>E</b>							
	<b>F1</b>						1°C	
	<b>F2</b>						2°C	
	<b>G</b>							
<b>Combinations</b>	<b>BC</b>							
	<b>DG</b>							
	<b>EG</b>							
	<b>EF</b>							1°C
	<b>FG</b>							1°C
	<b>DFG</b>							1°C
	<b>EFG</b>							1°C

Wall insulation (C) is the single measure with the lowest energy demand for all occupancy types, followed by the boiler upgrade (A). Service level measures of temperature reduction (F) and partial heating (G) show potential for significantly reducing energy demand. Comparable energy demand is calculated for improvements in roof insulation (B) and zonal heating controls (E) (in all but working family occupancy pattern). For combinations of measures, energy demand is lowest for full passive system upgrade (insulation of wall and roof (BC)), closely followed in two of the occupancy patterns by service level changes of 1 °C temperature reduction combined with partial heating and zonal heating control (FG, EFG).

### 5.5.2 Comparison of EEM savings across occupancy patterns

The savings in heating energy demand have been calculated compared to the initial scenario. These are shown in Figure 5-8 and are ranked for each occupancy pattern in Table 5-16.



**Figure 5-8** Modelled energy savings for single and combinations of energy efficiency measures for three occupancy patterns. EEMs are given in Key in Table 5-15.

For some EEMs, calculated energy savings are similar for all three occupancy patterns. These include roof (B), wall (C) and combined insulation (BC), boiler upgrade (A) and temperature reductions (F). In contrast, the savings vary greatly between occupancy patterns for heating control measures, partial under-heating and a variety of combinations therein. Partial under-heating (G) shows large savings (17-18 %) in the houses with less than full occupancy (working couple and daytime-present couple), whereas no savings are expected for the working family who would make full use of all rooms of the whole house. Thermostatic radiator valves (D) achieve greater savings for cases with higher occupancy hours; 9 % for the couple present in the daytime whilst only 5 % for the working couple. Zonal heating controls (E) enable greatest savings for the working couple who can make full use of the functionality of controlling heating remotely to coincide with their variable daily pattern. Greater energy saving potential was calculated for the day-time present couple and working couple for whom savings above 20 % were predicted for seven and five EEMs respectively.

5.5. Calculation of energy savings achievable with the implementation of EEMs

*Table 5-16 Energy demand savings calculated for single and combinations of EEMs for three occupancy patterns, ranked and grouped according to level of savings achieved (Italics are used for combined measures, shaded measures are those which do not apply)*

Energy Savings	Working Family %	Working Couple %	Daytime-present Couple %
<i>Initial Demand</i>	<b>17,940 kWh/yr</b>	<b>17,050 kWh/yr</b>	<b>21,260 kWh/yr</b>
<b>&gt;25 %</b>	Roof <b>and</b> Wall insulation 30	Roof <b>and</b> Wall insulation 31 <i>1 °C temp reduction and partial under-heating</i> 25	Roof <b>and</b> Wall insulation 32 <i>1 °C temp reduction, partial under-heating and AZHC</i> 29 <i>1 °C temp reduction and partial under-heating and TRV</i> 25
<b>20-25 %</b>		<i>1 °C temp reduction, partial under-heating and AZHC</i> 24 <i>1 °C temp reduction and zonal heating</i> 21 <i>Partial under-heating and AZHC</i> 20	<i>1 °C temp reduction and partial under-heating</i> 24 <i>Partial under-heating and AZHC</i> 24 Wall insulation 20 <i>1 °C temp reduction and AZHC</i> 20
<b>15-20 %</b>	Wall insulation 19 Boiler upgrade 19 <i>1 °C temp reduction and AZHC</i> 18 <i>1 °C temp reduction, AZHC and partial under-heating</i> 18 Temperature reduced by 2 °C 17 <i>1 °C temp reduction and TRV</i> 15	Wall insulation 19 Boiler upgrade 19 <i>1 °C temp reduction and partial under-heating with TRV</i> 18 Partial under-heating 18 Temperature reduced by 2 °C 17 AZHC 15	Boiler upgrade 19 <i>Partial under-heating with TRV</i> 18 Temperature reduced by 2 °C 18 Partial under-heating 17
<b>10-15 %</b>	Roof insulation 11 AZHC 11	<i>Partial under-heating and TRV</i> 12 Roof insulation 11	Roof insulation 12 AZHC 11
<b>5-10 %</b>	Temperature reduced by 1 °C 9 TRV 6 <i>TRV and partial under-heating</i> 6	Temperature reduced by 1 °C 9 TRV 5	TRV 9 Temperature reduced by 1 °C 9
<b>&lt;5 %</b>	Partial under-heating 0		

## 5.6. Results validation and sensitivity analysis

### 5.6.1 Statistical validation

A residential building is a complex system in which technical aspects such as structural engineering, thermodynamics and heat transfer interact with many human elements; not only how occupants use and live in their house, but also the competence with which the house was constructed and any upgrades are implemented. Consequently, even if the engineering calculations are complete, there will be limitations in how accurately the model can represent reality. Simplification made by the author (for infiltration, ventilation, internal gains and detailed occupant interactions with the house) mean that the modelled results cannot be expected to perfectly represent real world energy use. However, by comparing the simulation values to similar figures from other sources, the results can be critically assessed.

For overall energy consumption, a statistical benchmark has been taken from the UK Government's Department of Energy and Climate Change (DECC) National Energy Efficiency Data-framework (NEED) (DECC 2014c). Greater detail on the statistical validation process is provided in Appendix C.1. The dataset provides measures of gas and electricity use from 3.5 million UK homes for 2012, classified by regional location, house type, number of bedrooms and energy supply. Gas usage figures for a three bedroom semi-detached house in South East England are considered as the best match to the building model in this work based on the external temperature profile match as analysed in Appendix C.1. The chosen year of construction is pre 1919 as 86 % of houses built in this period have a solid wall construction. The level of energy efficiency cannot be ascertained, but is expected to be more representative of the pre-EEM figures as initial values used in the model are based on typical current levels.

Statistical data represents all gas use and therefore conversion is required for comparison to heating gas usage only as calculated in this chapter's model. National statistical data of domestic energy consumption by end use quotes space heating as accounting for 69 % of total gas use (DECC 2014a; DECC 2014b) and therefore this factor will be applied to the statistical benchmark to convert figures to space heating energy only. The adjustment disregards occupancy pattern in making the conversion from total gas use to gas consumed for space heating, due to a lack of more specific data; although gas use for cooking and hot water can be assumed to be lower for a couple than a family, it is not clear how occupancy type would affect the proportion of total gas consumption used for space heating.

In order to validate the individual EEMs, comparable data has been taken from literature. This data comprises statistical average energy savings for insulation and boiler upgrades, an empirical study into energy savings achieved by zonal heating control and modelling work using the Cambridge Housing Model (Hughes 2011) into energy savings by common household 'behaviours'. Model results, statistical benchmarks and representative values for EEM energy savings are presented in Table 5-17.

*Table 5-17 Comparison between model data and data taken from literature for total energy demand and savings due to EEMs*

	Comparison Data					Model data		
	Data type	Sample size	Median Value	Upper quartile	Lower quartile	Working Family	Working Couple	Daytime-present Couple
Annual gas consumption (kWh/yr)	S <sup>1,a</sup>	7000	16,600	21,400	12,300	-	-	-
Annual heating demand / consumption (kWh/yr)	S <sup>1,b</sup>	7000	11,300	14,600	8,400	18,594	17,636	22,202
<b>Energy Efficiency Measures</b>			<b>Energy savings (%)</b>					
Roof insulation	S <sup>2</sup>	20,470	2.8	18	-13	11	11	12
Solid wall insulation	S <sup>2</sup>	830	14.2	31	-3	19	19	20
Boiler upgrade - all house types - 3 bedroom semi-detached	S <sup>2</sup>	13,970 3,410	10.7 12.4	27.9 27.5	-5.7 -7.7	19	19	19
Zonal heating controls	E <sup>3</sup>	1	14.1	-	-	11	15	11
Thermostat temp reduced - 1 °C - 2 °C	M <sup>4</sup>	-	9 13	-	-	9 17	9 17	9 18
Partial under-heating of house	M <sup>4</sup>	-	4	-	-	0	18	17

S: Statistical average; E: Empirical study; M: Model estimates

Data Source: <sup>1</sup>(DECC 2014c); <sup>2</sup>(DECC 2013a); <sup>3</sup>(Beizaee et al. 2015); <sup>4</sup>(Palmer et al. 2012).

Notes: <sup>a</sup> Data for all gas consumption; <sup>b</sup> Data converted to heating demand only by multiplying factor of 0.69;

The model calculated value of annual heating demand is significantly higher than the statistical values for gas space heating consumption. This discrepancy could be due to modelling approximations, such as incorrect assumptions of the state of a typical home prior to energy efficiency improvements or neglect of internal heat gain (including secondary heating using a fuel other than natural gas). Were internal heat gains to have

been included, estimates of typical heat gains within a domestic house can be made based on figures used by Beizaee et al (2015). Approximate annual values of heat gains during the heating season would be 2,000 kWh for the working family, 1,500 kWh for the working couple and 3,200 kWh for the daytime-present couple. If these heat gains were assumed to directly replace heat demand, the modelled annual heating demand values could be reduced to approximately 16,600 kWh, 16,100 kWh and 19,000 kWh for the working family, working couple and day-time present couple respectively. These reduced heat demand values still greatly exceed the statistical values, but other factors could also be taken into account. A number of occupancy related inputs could have been included, such as appliance use, window opening habit and use of secondary heating, but it has been beyond the scope of the project to analyse their effects and instead only occupancy pattern was included in this study. The disagreement could also result from errors in the conversion between calculated space heat demand and measured gas consumption, a step which is very sensitive to the assumed values for boiler efficiency and percentage of gas consumption due to space heating. In reality, heat demand is not always satisfied within a system, but a model assumes that it is; the model in this study uses the method of heat demand calculation typically used in engineering model calculations, but does not represent the actual functioning of a central heating system.

When comparing the model predicted savings with values taken from literature, some EEMs show a good match and others significantly disagree. Zonal heating control and thermostat temperature reduction of 1 °C show a close match between modelled and comparison values. Solid wall insulation and 2 °C thermostat temperature reduction are in fair agreement. Savings values for roof insulation, boiler upgrade and partial under-heating of the house do not correspond. With regards to partial under-heating of the house, this discrepancy could be due to neglecting internal air flow between zones; flow of heat from a warmed room to a cool room would reduce the energy savings overall. However, the comparison value is also the result of modelling work (rather than empirical study) and therefore errors in assumptions by Palmer et al. (2012) could also contribute to the discrepancy. The modelled values for roof insulation and boiler upgrade savings are far higher than the median value taken from DECC's statistics, though they are significantly less than the value of the upper quartile. The broad range of values for measured savings following roof insulation can be due to different states of roof insulation prior to the intervention, or poorly installed insulation which falls short of required building standards. Another reason for the discrepancy between modelled and measured savings could be rebound effects whereby energy savings are compromised by households taking other benefits (such as comfort taking by raising the internal temperature) (Sorrell 2009; Alcott 2005). The rebound effect is further investigated in section 5.6.3.

### 5.6.2 Sensitivity analysis

Sensitivity analysis is a useful process for understanding how each value (whether known with certainty or an assumption) affects the overall result. Internal demand temperature has been identified as the most significant parameter in sensitivity analyses published in other papers (Blight & Coley 2013; Firth et al. 2010; Hughes et al. 2013), followed by heating system efficiency, external temperature, total floor area, storey height and daily heating hours (Hughes et al. 2013). A local sensitivity analysis is conducted on the model used in the present work using a one-at-a-time approach as adopted by Firth et al. (2010). The process for this sensitivity analysis is to vary key input parameters by a small increment above and below the initial set value for the parameter. The model is run for each of these new values and the change in the output parameter is calculated. From these values, a sensitivity coefficient is calculated according to equation (5-1) which is normalised to make these values comparable regardless of the scale and units used according to equation (5-2).

$$\frac{\partial y_i}{\partial k_j} \approx \frac{y_i(k_j + \Delta k_j) - y_i(k_j - \Delta k_j)}{2\Delta k_j} \quad (5-1)$$

$$i = 1, \dots, n \text{ and } j = 1, \dots, m$$

$$S_{ij} = \frac{k_j}{y_i} \frac{\partial y_i}{\partial k_j} \quad (5-2)$$

Where  $y_i$  is the  $i^{\text{th}}$  output variable

$k_j$  is the  $j^{\text{th}}$  input parameter

$\frac{\partial y_i}{\partial k_j}$  is the sensitivity coefficient for output value  $y_i$  and input parameter  $k_j$

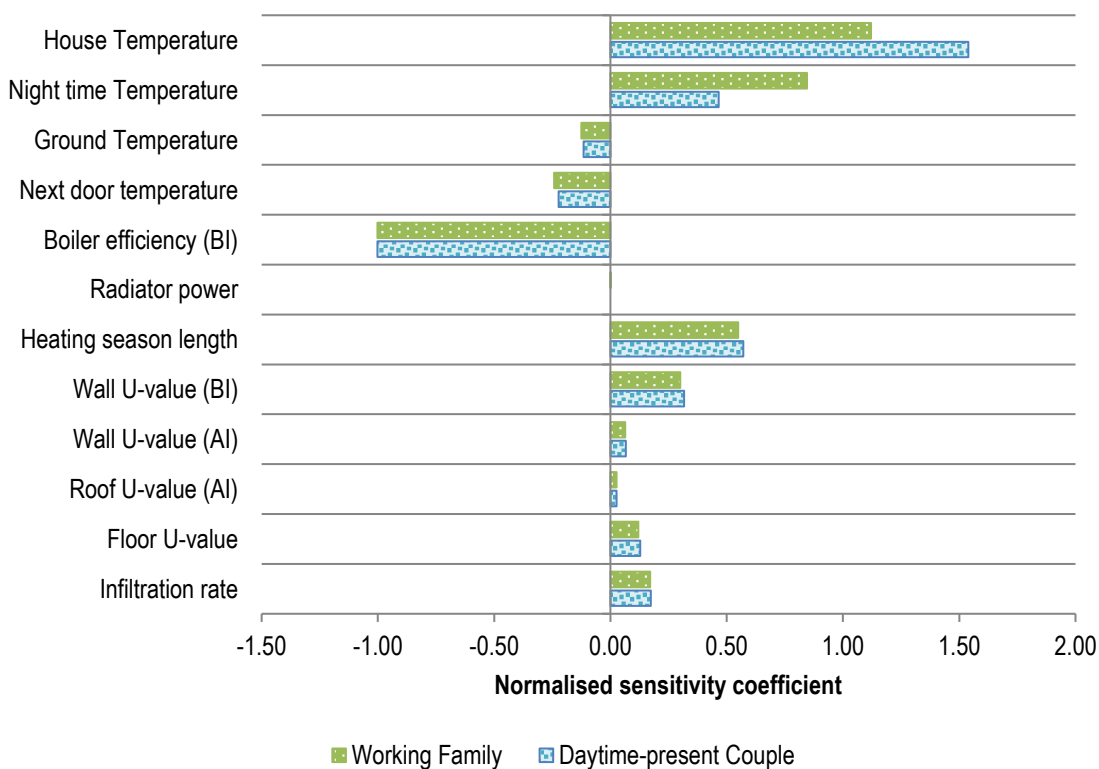
$y_i(k_j \pm \Delta k_j)$  is the value of  $y_i$  when the input parameter has increased or decreased by a small increment  $\Delta k_j$

The size of the incremental change is recommended in literature as 1 % of the initial value. However, a small value such as this can lead to rounding errors in the output value. The linearity of the model response will also affect the sensitivity result; if the model is linear with respect to the input variable, the size of the incremental change will be less important than if the model is non-linear with respect to the input variable. For the sensitivity analysis in the present study, two values are tested, corresponding to  $\Delta k_j = 1\%$  and  $\Delta k_j = 5\%$  of input variable. The calculated values of the corresponding sensitivity coefficient will be compared to each other to determine if the inputs are linear or non-linear as shown in Table 5-18. A criterion for linearity is chosen as a difference in sensitivity coefficient of less than 3 % between an incremental change ( $\Delta k$ ) of 1 % and 5 %. The sensitivity coefficients of each input variable are then compared to each other and this is presented in Figure 5-9. Further details of all calculations are given in Table. C-7 and Table. C-8 in Appendix C.2.

Sensitivity analysis is applied to the working family and daytime present couple occupancy patterns to compare whether the service demand affects the results.

*Table 5-18 Assessment for linearity of normalised sensitivity parameters for EEMs for working couple and daytime-present couple occupancy patterns. Key: BI: Before intervention; AI: after intervention.*

Model Parameter		Normalised Sensitivity coefficient, Sij						Linearity
		Working Family			Daytime Present Couple			
		1 %	5 %	Diff.	1 %	5 %	Diff.	
<b>House Temperature</b>	°C	1.120	1.121	0.1 %	1.540	1.000	0.0 %	L
<b>Night time Temperature</b>	°C	0.851	0.840	-1.3 %	0.463	1.011	-1.1 %	L
<b>Ground Temperature</b>	°C	-0.126	-0.126	0.0 %	-0.115	1.000	0.0 %	L
<b>Next door temperature</b>	°C	-0.242	-0.242	0.0 %	-0.222	1.000	0.0 %	L
<b>Boiler efficiency (BI)</b>	-	-1.000	-1.003	0.2 %	-1.003	0.998	0.2 %	L
<b>Radiator power</b>	kW	0.000	0.000	0.0 %	0.000		0.0 %	L
<b>Heating season length</b>	days	0.576	0.523	-10.2 %	0.536	1.130	-13.0 %	N
<b>Wall U-value (BI)</b>	W/(m <sup>2</sup> K)	0.351	0.250	-40.3 %	0.263	1.403	-40.3 %	N
<b>Wall U-value (AI)</b>	W/(m <sup>2</sup> K)	0.077	0.050	-54.8 %	0.052	1.548	-54.8 %	N
<b>Roof U-value (AI)</b>	W/(m <sup>2</sup> K)	0.025	0.027	7.1 %	0.027	0.928	7.2 %	N
<b>Floor U-value</b>	W/(m <sup>2</sup> K)	0.123	0.117	-5.2 %	0.124	1.055	-5.5 %	N
<b>Infiltration rate</b>	ach	0.172	0.169	-1.3 %	0.172	1.013	-1.3 %	L



*Figure 5-9 Normalised sensitivity parameter comparison of EEMs for working couple and daytime-present couple occupancy patterns*



The sensitivity coefficient is found to be linear for all parameters except building envelope U-value and length of heating season. The model is shown to be most sensitive to the temperature set-point during the daytime and night time and the boiler efficiency. The boiler efficiency has approximately negative directional proportionality whereby a 1 % increase in boiler efficiency leads to a 1 % decrease in heating consumption. House temperature is greater than proportional such that a reduction of 1 % of set-point temperature leads to a reduction in heating consumption of more than 1 %. The model is less sensitive to ground temperature, next door temperature and U-value of the building envelope and therefore the values of these parameters appear to have less effect on the results.

In comparison between the sensitivity coefficients for the working family and daytime-present couples, most parameters show little difference. The exceptions are the temperature related parameters with much greater variation. The daytime-present couple occupancy pattern shows a greater sensitivity to house temperature set-point during the day and this can be attributed to the fact that the house is occupied for a greater length of time during the day. In contrast, the daytime-present couple occupancy pattern is less sensitive to the night-time temperature than the working family occupancy pattern and this may be because more heating during the daytime results in less heating being required at night for the daytime-present couple.

### 5.6.3 Consideration of rebound

Energy savings following energy efficiency improvements can be compromised by rebound effects such as comfort taking. The impact of a comfort taking rebound effect on the energy savings calculated in this chapter have been investigated in the form of a comfort taking of 1 °C internal temperature increase between the initial case (at initial temperature) and following the adoption of an EEM (revised temperatures are given in appendix Table. C-9). The impact of this rebound effect on calculated energy savings is shown in Table 5-19. A loss in savings between 2 % and 6 % is calculated and this varies between the EEMs and occupancy types. Despite this loss in energy savings, a 1 °C comfort taking rebound effect does not change the ranking of any EEMs and therefore the results of this chapter. Inclusion of a rebound effect could however enable the model results to more closely represent the statistical validation results in Table 5-17.

*Table 5-19 Effect of a 1 °C comfort taking rebound effect on calculated savings*

Energy Efficiency Measure	Working Family			Working Couple			Daytime-present Couple		
	Initial savings	Revised saving	Saving reduction	Initial savings	Revised saving	Saving reduction	Initial savings	Revised saving	Saving reduction
<b>B Solid wall Insulation</b>	19 %	12 %	4 %	19 %	13 %	4 %	20 %	12 %	6 %
<b>C Loft Insulation</b>	11 %	5 %	6 %	11 %	6 %	6 %	12 %	4 %	8 %
<b>D Use of TRVs</b>	6 %	2 %	4 %	5 %	1 %	4 %	9 %	3 %	6 %
<b>E Use of AZHCs</b>	11 %	7 %	4 %	15 %	13 %	2 %	11 %	5 %	6 %
<b>G Partial under-heating</b>	-	-	-	18 %	15 %	3 %	17 %	12 %	5 %

## 5.7. Discussion

### 5.7.1 Comparison of energy efficiency measures

In this chapter, seven energy efficiency measures (EEMs) and combinations thereof have been compared based on how they can reduce energy consumption for a typical house over a year's period. These EEMs fit within four approaches to delivering the energy service of heated thermal comfort with less energy demand; improved passive system, higher efficiency conversion device, improved service control and decreased service level. The service demanded has been defined according to three typical occupancy patterns; a working family, a working couple and a daytime-present couple. In single measures or in combination, improved passive system in the form of insulation showed the greatest saving potential for all occupancy patterns. This was followed by a high efficiency boiler. Energy savings achievable through heating control and service level reduction were found to vary more in relation to the occupancy type. Zonal heating controls gave greatest saving potential to the working couple occupancy type whose variable daily pattern is able to make full use of the advanced zonal heating controls (AZHC) functionality of controlling heating remotely. Partial under-heating was calculated as enabling significant energy savings for those households with only two occupants, but was not applicable to the working family who make full use of all space within the house.

These model findings provide insight for the suitability of EEMs for different householder characterisations. For householders motivated by financial savings (cost), all EEMs would be suitable as they delivered energy savings, with the exception of solid wall insulation due

to the high upfront cost. Equivalently, all EEMs are recommended as suitable for householders motivated by environmental protection (climate).

The accuracy of the present model has been assessed through comparison of modelled results with validation data from literature in section 5.6.1, and this has given insight into the reliability of this chapter's findings. The calculated savings values for insulation measures and boiler installation were within the upper and lower quartile range of the empirical statistical data, but were 5 – 9 % higher than the median values and therefore greater validation work is required before the models could be used to confidently make recommendations on the potential for energy savings from these technologies. The discrepancy could be due to rebound effects, calculated in section 5.6.3 to cause a 4 – 8 % reduction in energy savings, or due to greater factors in heating practices not being included in the modelling (as discussed below). Energy saving calculations for EEMs of heating control and a 1 °C reduction in set-point temperature showed better agreement with validation values. A wide discrepancy was found for the level of energy savings expected for partial heating between the present model and results from another model study (Palmer et al. 2012), and therefore empirical validation is required in order to gain a better understanding of the true level of energy savings which can be expected from such a reduction in service level demand. The results of a sensitivity analysis using the one-at-a-time global sensitivity method showed that the model was most sensitive to the values of set-point temperature and boiler efficiency, agreeing with findings of other similar studies (Blight & Coley 2013; Firth et al. 2010; Hughes et al. 2013).

The variations in energy consumption predicted by the model are not as large as have been measured between similar houses (DECC 2013a; Beizaee et al. 2015), and this could be explained by the observation that occupancy characteristics include more than the occupancy patterns discussed here. Other factors, such as opening windows and doors for ventilation, and use of secondary heating will also contribute to the variations in energy consumption for different occupants (as discussed in sections 2.2.1 and 2.2.3.1). The initial state of a building is another key factor in the size of, and variation in, calculated energy savings. In this study, for the sake of simplicity, the initial state of the house and its occupants was based on a 'typical' UK dwelling, but with a larger variation in initial state, a wider range of saving would be expected. The savings calculated will also depend on the extent to which EEMs are implemented.

### **5.7.2 Suitability of energy efficiency measures to occupants**

In reality, the suitability of some EEMs will vary according to the household occupants, and this must always be taken into account when making recommendations for the adoption of such measures. The suitability of EEMs could be further informed by

consideration of heating practices as the way householders attain thermal comfort for themselves. Of the fourteen heating behaviours identified from literature in Table 2-5, length of occupied period or heating period has been most thoroughly covered in the modelling of this chapter, represented in the three occupancy patterns of working family, working couple and daytime-present couple. Temperature set-point and portion of house heated have been investigated as EEMs of lower service level; personal heating is also related to this as a lower temperature set-point can be comfortable with the addition of clothing or other adaptive measures. For households who exhibit practices of personal heating, EEMs of service level could be suitable, unless their level of service is already low. Temperature reduction may not, however, be suitable for those occupants who are elderly or suffering from health conditions, and the use of advanced heating controls will not suit all types of people (as discussed in section 2.3.4.5).

The different types of barriers posed by each EEM were indicated in Table 5-12. When applying this analysis to individual households and buildings, these further context-specific details could take the application beyond the three occupancy patterns explored in this paper, by categorising households according to age, physical ability, tenure type (owned vs rented) or capacity to overcome different barriers. Passive system and conversion device measures resulted in similar savings for all three occupancy types and therefore exhibited greatest resilience to changing households. These measures can therefore be particularly recommended in houses with a high turnover, such as the rental sector. Cost, as a major barrier to adoption of EEMs, has been addressed within this chapter by comparing combinations of low cost measures to higher cost individual measures. Cost constraints of larger measures such as passive system and conversion device upgrade will limit some households more than others. Lower cost measures tend to require greater expertise or present a greater inconvenience, and therefore will only result in maximum savings if suitably matched to the household.

### 5.7.3 Inclusion of additional heating practices

The inclusion of other heating practices, as identified in Table 2-5, could provide further insight into suitability of EEMs for householders with different types of behaviours. Approaches to how these practices could be included within building modelling are explained below:

- **Interaction with heating controls:** Type of thermostat and interaction with the thermostat have been investigated as control EEMs, and the competence of a household to use such controls will affect the adoption potential of such measures. However, thus far controls have been modelled according to their designed

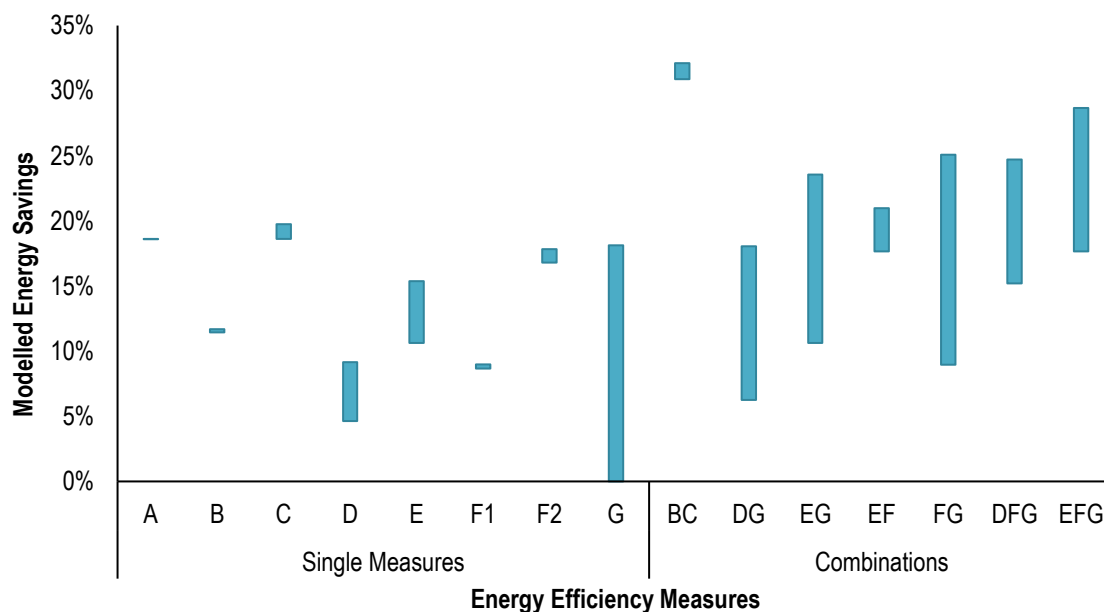
operation mode, but empirical studies have revealed heating control technologies being used in adapted ways and contrary to their desired function. An example is that some occupants control heating by overriding a thermostat to use it like an on-off switch (turning up to 30 °C for 'on' and down to 10 °C for 'off'). Representation of this heating behaviour could be achieved by assigning a wide temperature dead-band to the thermostat during occupied hours and could be more representative of real heating practices.

- **Use of secondary heating:** The use of secondary heating can be split into two types; an additional heating source (such as an electric heater) used when the primary heating source is insufficient to warm the room or house to a comfortable temperature and switched on when the room temperature is deemed too cold, or a 'rustic' type of heat source such as a wood or gas fire which is lit in a living space for heating and 'aesthetic' reasons. Secondary heating can be modelled as a heat gain, and commonly the heat input can be differentiated into convective and radiative heat; secondary heating sources typically emit more radiative power than a conventional central heating system. An aesthetic type of heating source could be modelled on a schedule, such that it is lit for a few hours every evening in the living room. For the supplementary heating type of secondary heating source, a secondary thermostat could be modelled, representing the internal thermostat of an occupant; the heat source could be controlled based on the temperature dropping below a certain level in an occupied space in which it is commonly used. The availability of conditional control within building models (whereby an action is taken depending on a statement being evaluated as TRUE or FALSE), or set-point temperature bounds as upper and lower limits, could enable more realistic representation of the conscious or unconscious decisions upon which heating practices depend. Apart from modelling, use of secondary heating as a heating behaviour could be an indication of a household's priority for comfort over cost or environment. For a householder who is motivated by comfort, savings offered by an EEM may be negated if a sufficient level of warmth is not being delivered and heating is supplemented by the use of secondary heating; this could lead to significantly higher CO<sub>2</sub> emissions, depending on the fuel source of the secondary heating.
- **Internal door opening:** The tendency of a household to leave internal doors open can be expected to impact particularly on EEMs in which different parts of the house are heated differently. Advanced zonal heating control can be compromised if internal doors are not kept predominantly shut between heated and non-heated rooms. Partial heating would also not be effective unless un-heated spaces are shut

off from heated spaces. The effect of open internal doors can be modelled by specifying internal air flow between air nodes or zones in the model. However, it may be more effective to simply avoid recommending these zonal EEMs for occupants who have a preference for keeping internal doors open.

- **Window opening:** Open windows can be modelled as a natural ventilation by specifying a ventilation rate of air at the external temperature. Specifying the rate of ventilation is non-trivial as it relies on factors such as internal and external temperatures and external wind speed. Jack et al. (2015) found a linear relationship between window open area and ventilation rate, with an increase of 2 ach (for the whole house) between window closed and window open by 0.6 m<sup>2</sup>, extrapolated to 3.8 ach per m<sup>2</sup> of opening area. Infiltration is expected to be higher at higher external wind speed (compared to average wind speed of 2.0 m/s on the day of the test), however window opening behaviour was found to be less likely at higher external wind speeds (Fabi et al. 2012).

With the inclusion of such heating practices, the accuracy of the savings prediction may be enhanced, or alternatively, the range of expected savings may be widened. This wider expected range could be displayed graphically in the results figure. Figure 5-10 shows such an example, for the case when the occupancy pattern of the household is uncertain and therefore all three occupancy patterns of working family, working couple and daytime-present couple are displayed on the same plot. The inclusion of a greater number of heating practices would make the range wider and better represent the variety of savings which could be expected following the adoption of an EEM.



**Figure 5-10** Range of modelled energy savings for single and combinations of energy efficiency measures representing the uncertainty of energy savings if occupancy pattern is unknown. EEMs letters are explained in the Key in Table 5-15

## 5.8. Conclusion

The aim of this chapter has been to investigate the effectiveness of energy efficiency measures (EEMs) in reducing the energy required to deliver the service of heating thermal comfort within a typical UK house. As in Chapter 4, EEMs were compared based on the energy demand calculated to deliver a given functional unit of service, in this case a year of thermal comfort as defined by the occupancy pattern, and the energy savings which each EEM could deliver.

Although savings with the full passive system improvements (wall and roof) were calculated to be the highest for each occupancy pattern, they were also identified as being the most expensive, especially for solid wall houses. Combinations of less expensive and less invasive energy efficiency measures were found to deliver similar savings, but present their own barriers to widespread uptake. The savings have been shown to vary depending on the occupancy pattern of the household, and the policy consequences of these findings will be explored in Chapters 7 and 8. Overall, this work has contributed to the understanding of how service demand, in the form of occupancy patterns, affect domestic energy consumption and energy savings for a broad range of energy efficiency technologies and measures.

## Chapter 5. Energy savings for energy service defined by occupancy pattern

Thus far in this thesis, energy service demand has been used to compare EEMs and it has been assumed that all EEMs are delivering the same level of service. The following chapter focusses on how well the service is delivered by each EEM, within which the energy service delivery of heating thermal comfort will be modelled and calculated. By developing ways in which building energy models can compare the level of service delivered, consideration of the level of heating thermal comfort supplied with each EEM can be used in the recommendation of energy efficiency work.



# Chapter 6 Modelling service delivery of heating thermal comfort

## 6.1. Introduction

In the previous two chapters, modelling has been undertaken to calculate the energy demand savings attainable with energy efficiency technologies and measures. However, the calculated results do not give any focus on how well the technologies deliver the service of thermal comfort. The aim of this chapter is to investigate how energy efficiency measures (EEMs) can be compared by building energy models beyond only energy savings, and metrics are used for the measurement of thermal comfort. Four metrics will be used to compare ten EEMs for three occupancy patterns (as used in chapter 5) to gain insight into the effectiveness of different approaches to delivering thermal comfort. To achieve this aim, it is necessary to enhance the building modelling methodology used in Chapter 5 beyond the dynamic heat balance such that it can better represent a heating system in reality.

The chapter begins in section 6.2 with the identification of four metrics for the measurement of the delivery of heating thermal comfort (HTC). The technologies for comparison are mostly the same as in Chapter 5, and these are detailed in section 6.3. The enhanced building modelling methodology is presented in section 6.4. Section 6.5 contains the results generation and analysis for each of the four HTC metrics; averaged temperature (section 6.5.1), temperature profile (section 6.5.2), 'temperature shortfall stack' (section 6.5.3) and 'heating comfort gap' (section 6.5.4). The findings of the work in terms of recommendations for measuring the delivery of HTC and the relative performance of EEMs are discussed in section 6.6, and final conclusions for the chapter are made in section 6.7.

## 6.2. Measurement of service delivery

The literature review in Chapter 2 informed that along with Fanger's steady state energy balance metrics of PMV and PPD, average temperature and measured temperature profile are the two most common indices for thermal comfort measurement. For the measurement of service in this chapter, four options will be considered for thermal comfort delivery metrics. The satisfactory delivery of thermal comfort in this study is being defined as whether or not the desired comfort temperature is met by the modelled internal temperature in each room of the house. Average temperature and modelled temperature profiles will both be investigated in order to see how they can be predicted using building energy modelling software. Further to this, two metrics developed by the author are also utilised, which are a 'temperature shortfall stack' and a 'heating comfort gap' metric. These four metrics are described below and tested for a range of (EEM) in section 6.5.

### 6.2.1 Average temperature and average temperature during occupancy

Average temperature measurement is the simplest metric for comparing delivered service demand. Within domestic building energy research, average indoor temperature has been used as a proxy for thermal comfort (Shrubsole et al. 2015).

Although average temperature is most easily calculated when including an entire modelled period, the time in which average temperature is calculated can significantly affect results. Beizaee (2015) made comparisons of heating control strategies over an extended time period (a 56 day trial), using a temperature metric for the whole house which comprised a floor area weighted average daily air temperature. A conventional heating control strategy was found to deliver a higher average temperature than a zonal heating control approach; average temperature measurement for conventional control was consistently approximately 0.5 °C higher than for zonal control. However, further comparison was undertaken using an eight week average of indoor temperature for each room of the house based only on time when the heating is on, and when the rooms are 'occupied'; for this metric, average temperature was found not to have been affected by the heating control approach. This study demonstrates the importance of measuring thermal comfort delivery when it is required and not throughout the whole day.

In this work, average temperature will be calculated for both an overall average temperature (for a full 24 hour period,  $\bar{T}_{24hr}$ ) and an average temperature during occupied periods only,  $\bar{T}_{occ}$  for comparison. The overall average temperature of room  $j$ ,  $\bar{T}_{24hr,j}$ , will be calculated using a simple mean calculation as in (6-1) where  $T_{int,j}$  is the internal

temperature of room  $j$ ,  $t_{sim}$  is the total length of the simulation, and  $\delta t$  is the length of each time step (such that  $n_{\delta t}$  is the total number of time steps in the simulation).

$$\bar{T}_{24hr,j} = \frac{1}{n_{\delta t}} \sum_{t=0}^{24 \text{ hr}} T_{int,j,t} \quad \text{where } n_{\delta t} = \frac{t_{sim}}{\delta t} \quad (6-1)$$

Average temperature of room  $j$  when occupied,  $\bar{T}_{occ,j}$ , is calculated using the demand temperature profile as in (6-2)<sup>4</sup>

$$\bar{T}_{occ,j} = \frac{\sum \{ T_{int,j} \mid T_{dem,j} \geq T_{set,min,j} \}}{\{ n_{\delta t} \mid T_{dem,j} \geq T_{set,min,j} \}} \quad (6-2)$$

Where  $T_{set,min,j}$  is 20 °C for the living room and 18 °C for the bedroom.

### 6.2.2 Averaged daily temperature profile

Temperature profile is a line graph of modelled temperature as compared to the demanded temperature profile. The profile gives a clear visual comparison of how technologies are delivering HTC compared to the demanded level of service. The benefit of a temperature profile was demonstrated by Beizae et al. (2015) in their comparison of conventional heating control and zonal heating control strategies. Interpretation of results from a temperature profile of a single day showed that although conventional control delivered higher temperatures throughout most of the day, the delivered temperatures were similar for each control strategy during occupied periods, and therefore the delivery of thermal comfort was found not to have been compromised. A temperature profile clearly shows how well the house heating system can respond to changes in demand; where time lags exist (additional time taken to reach the set-point temperature) and where overshoots exist (heating beyond demand either in temperature (higher temperature than required) or time (heating on longer than required)).

The daily temperature profile is produced from the calculated internal temperature in each zone or air node of the model for each time step in the model. The internal temperature profile will vary throughout the day and the daily pattern will vary over the whole modelled period due to the changing external temperature. For the choice of a type of temperature profile with which to compare EEMs, two options are shown in Figure 6-1; (a) shows an extended modelled period, (here 10 days of the full 30 day period are displayed) and (b) shows a single day period made up of a temperature average over every time step

---

<sup>4</sup> Separator notation  $\sum\{a|b\}$  denotes sum of  $a$  for all time steps in which  $b$  is true

within the day. The former option presents lack of clarity when differentiating between different plot lines, especially if it is desired to display a whole modelled period (for example 30 days instead of 10). By averaging temperatures over an extended time period at each time step, an aggregate averaged daily profile can be used to represent the variation of delivered internal temperature between EEMs and allows for greater resolution for the comparison of many EEM scenarios. However, this is achieved at the expense of some loss of detail of thermal comfort satisfaction variation for different days within the modelled period.

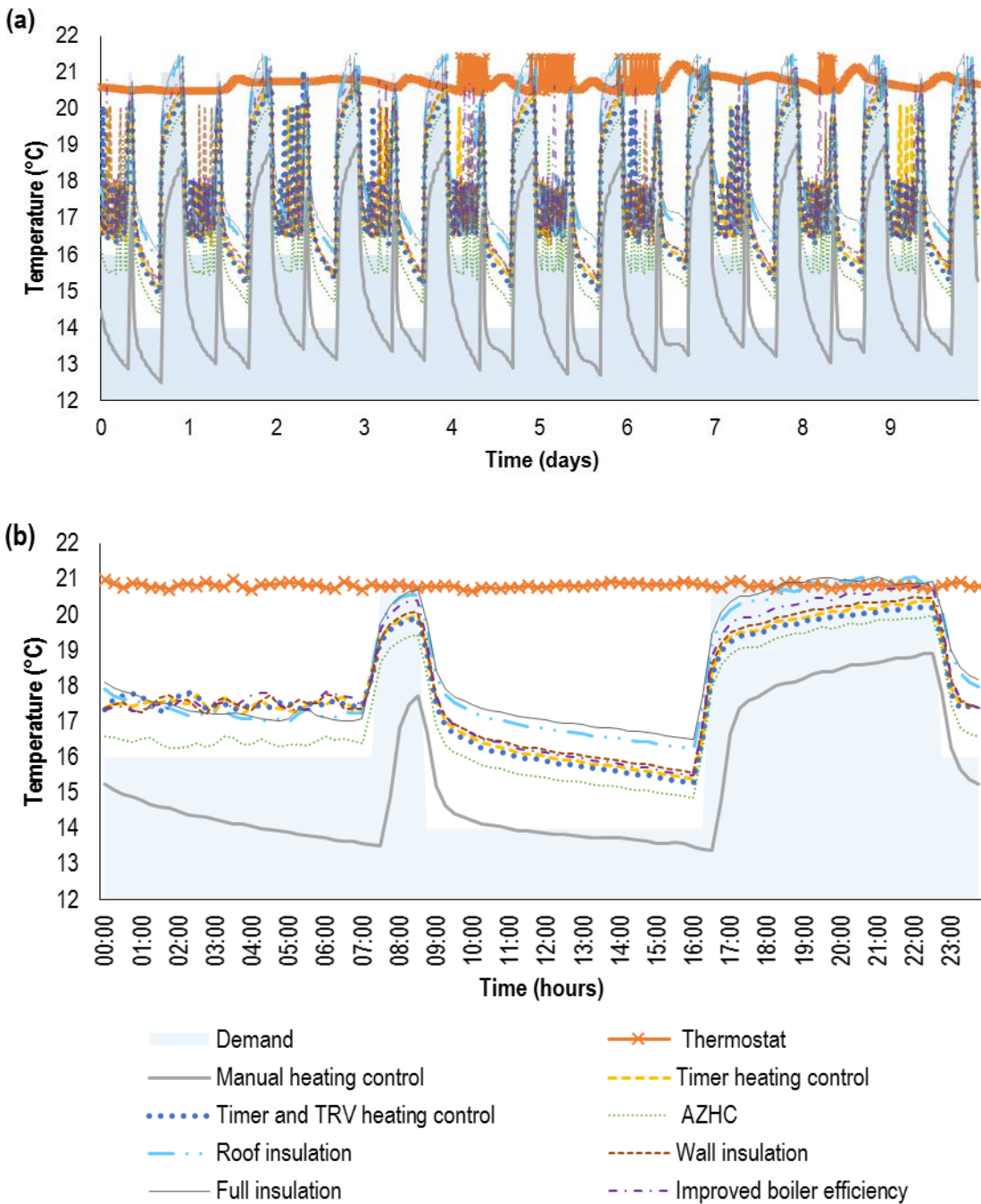


Figure 6-1 Comparison temperature profile plots showing (a) extended time period, (b) time averaged day profile. EEM scenarios are explained in Table 6-1.

### 6.2.3 Temperature shortfall stack

A development upon the temperature profile is named in this work as the ‘temperature shortfall stack’ which is a quantification of the extent to which delivered indoor temperature does not meet the temperature demand. Within the temperature shortfall stack, the time for which a room is below the demand temperature is summed for each integer degree of temperature ‘shortfall’. The stack displays the total hours that the temperature has a shortfall of 1 °C, 2 °C, 3 °C etc., plotted as bars of increasing darkness of colour and showing visually the scale of temperature dissatisfaction for each energy efficiency scenario. A temperature shortfall stack allows technologies to be compared visually based on how well they satisfy the temperature demand and the level of temperature shortfall over an extended period of time.

The calculation of each data bar of hours per average day,  $h_{sf,ij}$  for a shortfall of  $i$  °C in room  $j$  is given in (6-3)<sup>5</sup>, where the bracket notation dictates the occurrence or not of the internal temperature being below the demand temperature,  $n_d$  are the number of days in the modelled period,  $T_{dem,j,k}$  is the temperature demand in room  $j$  at time-step  $k$ ,  $T_{int,j,k}$  is the modelled internal temperature in room  $j$  at time-step  $k$ , and  $\delta t$  is the length of time-step used in the simulation.

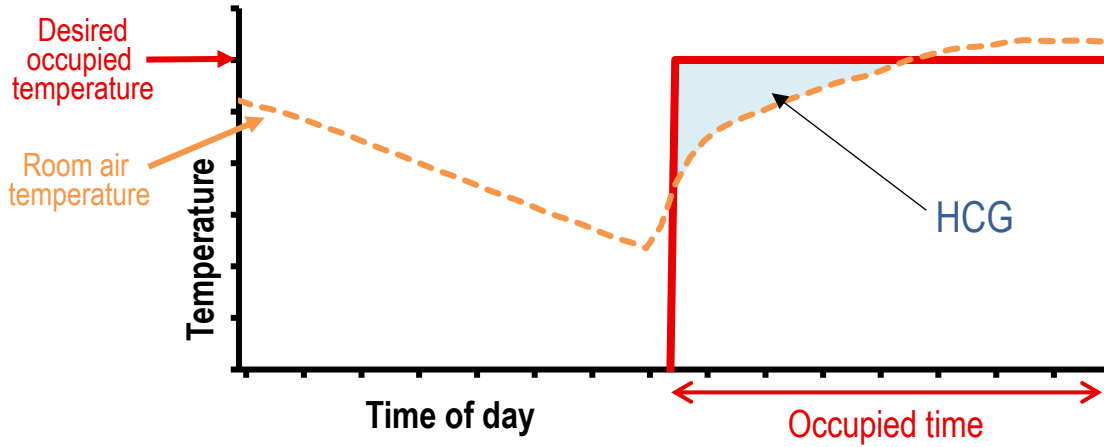
$$h_{sf,ij} = \frac{1}{n_d} \left( \sum_{k=t_{start}}^{k=t_{end}} [ i \leq (T_{dem,j,k} - T_{int,j,k}) < (i + 1) ] \right) \times \delta t \quad (6-3)^5$$

### 6.2.4 Heating comfort gap

Further developing upon the temperature profile and temperature shortfall stack, the heating comfort gap (HCG) is a single metric with which the temperature shortfall can be measured. The HCG is a relatively novel measurement for the extent to which a desired temperature profile has been delivered and is similar to the Weighted Discomfort Time described in Annex F of EN 15251 (European Standard 2006) which, at the time of writing this chapter, has only been found to have been previously used in literature three times (Penna et al. 2014; Atzeri et al. 2014; Carlucci et al. 2014). The HCG is based on the modelled temperature profile compared to the desired temperature profile and is derived

---

<sup>5</sup> Bracket notation denotes  $[P] = 1$  if  $P$  is true,  $[P] = 0$  if  $P$  is false.



*Figure 6-2 Illustration of the calculation of the Heating comfort Gap (HCG)*

from the method for the calculation of degree-days (as described in Box 2-3, representing both the scale of the shortfall and the length of time for which temperature demand is not met. The HCG metric is an integration of the area between the calculated temperature profile and temperature demand profile, for the time when the temperature is below the demand temperature, over an extended period, as illustrated in Figure 6-2, and calculated by equation (6-4).

$$HCG_j = \sum_{k=1}^n \int_{t_{start,k}}^{t_{end,k}} (T_{dem,jk} - T_{int,j} \mid T_{dem,jk} > T_{int,j}) dt \quad (6-4)$$

where  $t_{start,k}$  and  $t_{end,k}$  mark the start and end of the occupied period  $k$  out of  $n$  occupied periods in total,  $T_{dem,j}$  is the demanded temperature of room  $j$  during occupied period  $k$  and  $T_{int,j}$  is the internal temperature calculated by the model for each time step. The result is a single value for each investigated technology for the period of consideration. The accuracy of the HCG metric depends on the accuracy with which the internal temperature profile is modelled and is sensitive to the value of demand temperature which is used.

### 6.3. Energy efficiency technologies and measures

For the exploration of HTC delivery, a similar range of technologies and EEMs are considered as in Chapter 5; these again cover the four service aspects of conversion device, passive system, control (of delivery of heat) and service level. Further heating control options are included to represent a broader baseline of where houses may exist initially

### 6.3. Energy efficiency technologies and measures

(thermostat only control and manual control). The full range of technologies being considered in this chapter is given in Table 6-1.

*Table 6-1 Description of technologies and EEMs*

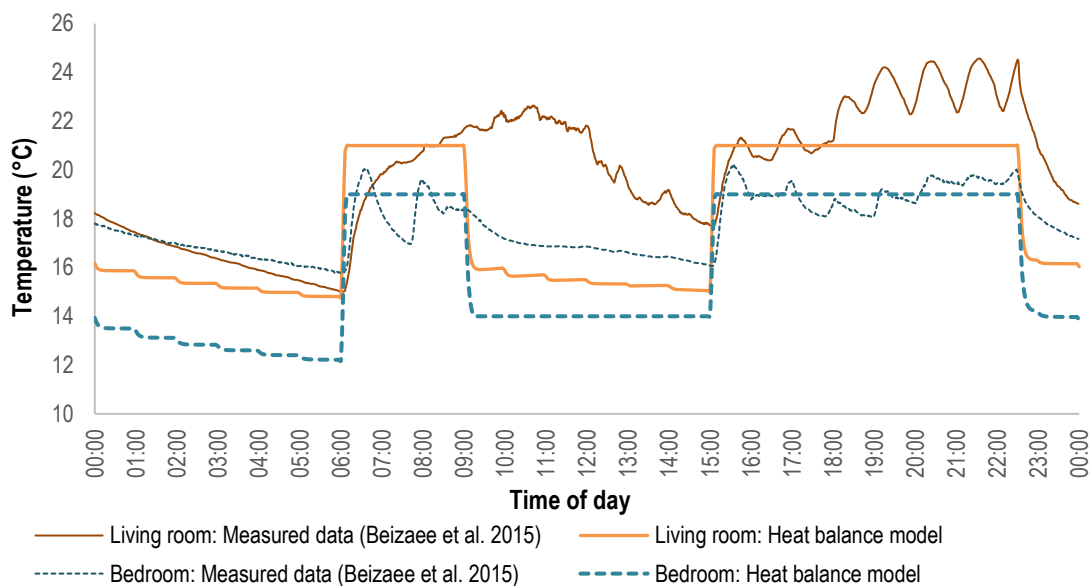
Technology		Description	Other parameters
Control	<b>Thermostat only control</b>	Temperature setting is maintained at 21 °C throughout day.	Boiler efficiency of 75 % Unimproved building envelope <sup>1</sup>
	<b>Manual control</b>	Heating is turned on when house is occupied and turned off when unoccupied and overnight. Temperature is controlled by thermostat at 21 °C.	
	<b>Timer control</b>	Heating is programmed to turn on 30minutes before regular occupancy period and turned off at the end of the occupied period. Temperature is controlled by thermostat at 21 °C.	
	<b>Timer and TRV control</b>	As above, but temperature set-point is varied across rooms of the house (as in Table 5-10).	
	<b>Advanced zonal heating control (AZHC)</b>	Temperature set-point and timing of heating is controlled separately in each room (boiler is still controlled from living room thermostat)	
Passive system	<b>Roof insulation</b>	Insulation of roof rafters to a U-value of 0.16 W/(m <sup>2</sup> K). Other building elements maintaining construction and U-values as given in Table 5-6.	Heating control of timer control as described above Boiler efficiency of 75 %
	<b>Wall insulation</b>	Internal insulation of solid walls to a U-value of 0.45 W/(m <sup>2</sup> K) and infiltration rate is reduced to 0.5 ach. Other building elements maintaining construction and U-values as given in Table 5-6.	
	<b>Full (Roof and wall) insulation</b>	Both roof and wall insulation as described above	
Conversion device	<b>Improved efficiency boiler</b>	Boiler efficiency of 88 %. With this efficiency improvement, power of heating in each room is increased by 10 % (from 1500 W to 1650 W)	Heating control: timer control Unimproved building envelope
Service level	<b>Temperature reduction (1 °C)</b>	Internal temperature reduced by 1 °C in each occupied zone (as detailed in Table 5-10)	Heating control: timer control Unimproved building envelope Boiler efficiency: 75 %

<sup>1</sup>Unimproved building envelope refers to insulation U-values: roof: 1.00 W/(m<sup>2</sup>K); wall: 1.44 W/(m<sup>2</sup>K) and infiltration rate across house of 0.75 ach. Other building elements maintaining construction and U-values as given in Table 5-6.

## 6.4. Building modelling

### 6.4.1 Enhanced building modelling motivation

For all metrics of thermal comfort delivery introduced in section 6.2, there is a requirement that building modelling is able to replicate the service delivery of an elevated internal temperature as accurately as possible. Typical heat balance models are not designed to achieve realistic temperature profiles; Figure 6-3 illustrates the discrepancy between a typical temperature profile as generated by the building model in Chapter 5 and a temperature profile as measured in a real house in response to a predictable heating pattern (Beizaee et al. 2015).



**Figure 6-3** Comparison of modelled temperature by typical heat balance building model used in Chapter 5 and measured temperature profile in real living room, taken from empirical work by Beizaee et al (2015) (Figure 5 therein).

In the modelled temperature profile, the air temperature responds immediately to a rise or fall in temperature set-point. In contrast, the measured temperature profile shows that the temperature lag-time is greater, leading to a smoother temperature profile throughout the day. Another difference is the shape of the temperature profile when a maximum temperature set-point is reached. In the modelled case, the profile is a flat line as the model calculates that the heat input is the exact amount required to maintain this temperature. Conversely, in the measured case, the temperature profile fluctuates as heat input raises the temperature above the set-point and the air takes time to cool back down to the set-point temperature. The clear discrepancy between modelled and measured temperature profile indicates that a modified model approach is required for the modelling of thermal comfort delivery in this chapter.



### 6.4.2 Building energy model development

As in Chapter 5, building modelling in this chapter is undertaken using TRNSYS software. However, the modular approach is used to a greater extent in the present work as additional units can enable the model to be developed to more closely represent a real heating system. The developments to the building energy model (BEM) are best described by comparing the new approach to the typical building energy model approach used in Chapter 5.

A typical building energy model is based on a heat balance. A house at an internal temperature  $T_{int}(t)$  receives heat gains and has heat losses over a time step ( $\delta t$ ), resulting in a new temperature,  $T(t + \delta t)$ .

The calculation of heat input to the house depends on the following criteria:

If:  $T_{int}(t + \delta t) < T_{set}(t + \delta t)$ , then add heat input,  $Q(t + \delta t)$   
 where  $Q(t + \delta t)$  is the energy sufficient to raise  $T_{int}(t + \delta t)$  to  $T_{set}(t + \delta t)$

If:  $T_{int}(t + \delta t) \geq T_{set}(t + \delta t)$ , then no heat input,  $Q(t) = 0$

The model has a maximum value for the rate of heat input, ( $\dot{Q}_{max}$ ), and this dictates the calculated temperature at the end of the time step, ( $T'_{int}$ ):

If:  $Q(t + \delta t) < (\dot{Q}_{max} \times \delta t)$ ,  $T'_{int}(t + \delta t) = T_{set}(t + \delta t)$   
 then:  $Q(t + \delta t)$  is calculated by the model

If  $Q(t + \delta t) > (\dot{Q}_{max} \times \delta t)$ , then:  $T'_{int}(t + \delta t)$  is calculated by the model  
 $Q(t + \delta t) = (\dot{Q}_{max} \times \delta t)$

The above process is followed for each time step throughout the heating period. The temperature profile is made up of values of  $T'_{int}$ , and heat demand is calculated as the sum of heat demand over each time step.

In reality, for a house with temperature heating control, the heating system works in a more dynamic, iterative way. The internal temperature and temperature set-points are compared by the heating control and this sends a signal to the heating system of whether it should be on or not, as follows:

If:  $T_{int}(t + \delta t) < T_{set}(t + \delta t)$ , then signal to heating system = ON

If:  $T_{int}(t + \delta t) \geq T_{set}(t + \delta t)$ , then signal to heating system = OFF

Due to thermal inertia in the heating system, the heat input will not reach maximum rate ( $\dot{Q}_{max}$ ) immediately upon a signal to turn ON, nor will the heat input rate fall to zero immediately upon receiving a signal to turn OFF. A heat input time lag will exist. The temperature profile will be calculated by the model treating the heat input as a heat gain.

The heat demand (energy consumption) will be at a maximum for the time that the heating signal is ON and total heating final energy demand will be calculated as in equation (6-5)

$$Q_{final} = \frac{\dot{Q}_{max}}{\eta} \times t_{|signal\ ON} \quad (6-5)$$

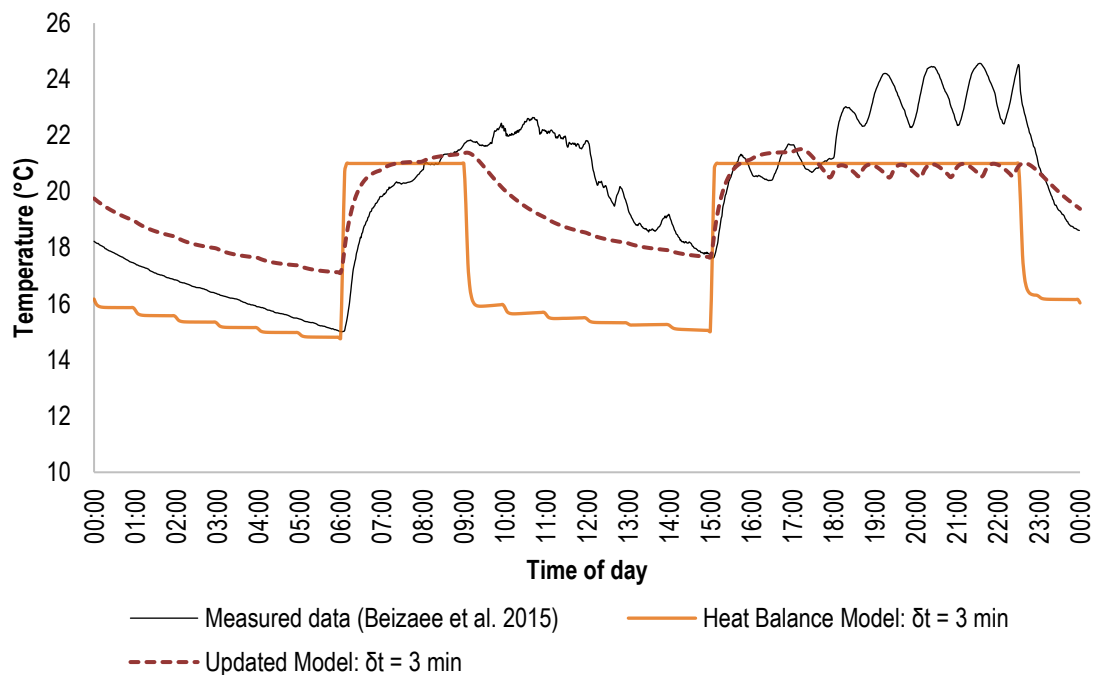
To incorporate this enhanced model approach into the TRNSYS building model, two new TRNSYS components are incorporated, corresponding to a radiator unit and a thermostat controller. These allow for the thermal inertia in the heating system to be included in the model. Further details of the enhanced building model approach are provided in Appendix D.1

### 6.4.3 Model validation

To test the performance of the developed BEM, three profiles are compared in Figure 6-4; a temperature profile generated by the heat balance model used in Chapter 5, temperature profile generated by the enhanced model (after model development as explained above in this section), and a temperature profile as measured in a real house by Beizaee et al. (2015). Modelled temperature profiles are for the living room and are based on the working family occupancy profile with pre-intervention levels of insulation and ‘Timer & TRV’ heating control, equivalent to the ‘conventional control’ used in the real house measurements. For comparison, the simulated temperature set-points used in the empirical study (Beizaee et al. 2015) have been replicated in the models. The modelled temperature profiles are generated with a time-step of 3 minutes which more closely match the time step of 1 minute in the measured data.

Further comparison figures including other occupancy patterns, comparison of 3 minute to 15 minute time steps and living room and bedroom profiles are presented in Figure. D-2 of Appendix D.2. The results of the data comparison between modelled and measured data show that the enhanced model better represents the shape of the temperature profile, including the rate of temperature rise and fall and the occurrence of fluctuation around maximum temperature. However, the rise in temperature during the unoccupied daytime period has not been replicated by the model and this could be explained by differences in solar gains which have not been matched between the weather of the empirical study and the weather file used for modelling. The effect of time-step on the modelled results, as

shown in Figure. D-2, are that a shorter time-step produces a smoother temperature profile, and more severe temperature spikes are calculated when a 15 minute time step is used.



**Figure 6-4** Comparison of modelled temperature profiles between heat balance model (as used in chapter 5), enhanced model (as used in this chapter) and measured data (taken from empirical work by Beizae et al (2015) (Figure 5 therein))

## 6.5. Results

### 6.5.1 Average temperature and average temperature during occupancy

Average modelled temperature values are shown in Figure 6-5, Figure 6-6, and Figure 6-7 for Working Family, Working Couple and Daytime-present Couple occupancy patterns respectively. These figures show overall average temperature and average temperature during occupied periods only for both the living room and bedroom. In each case, the averages of the modelled results (bars) are compared to the averages of the temperature demand profiles (lines).

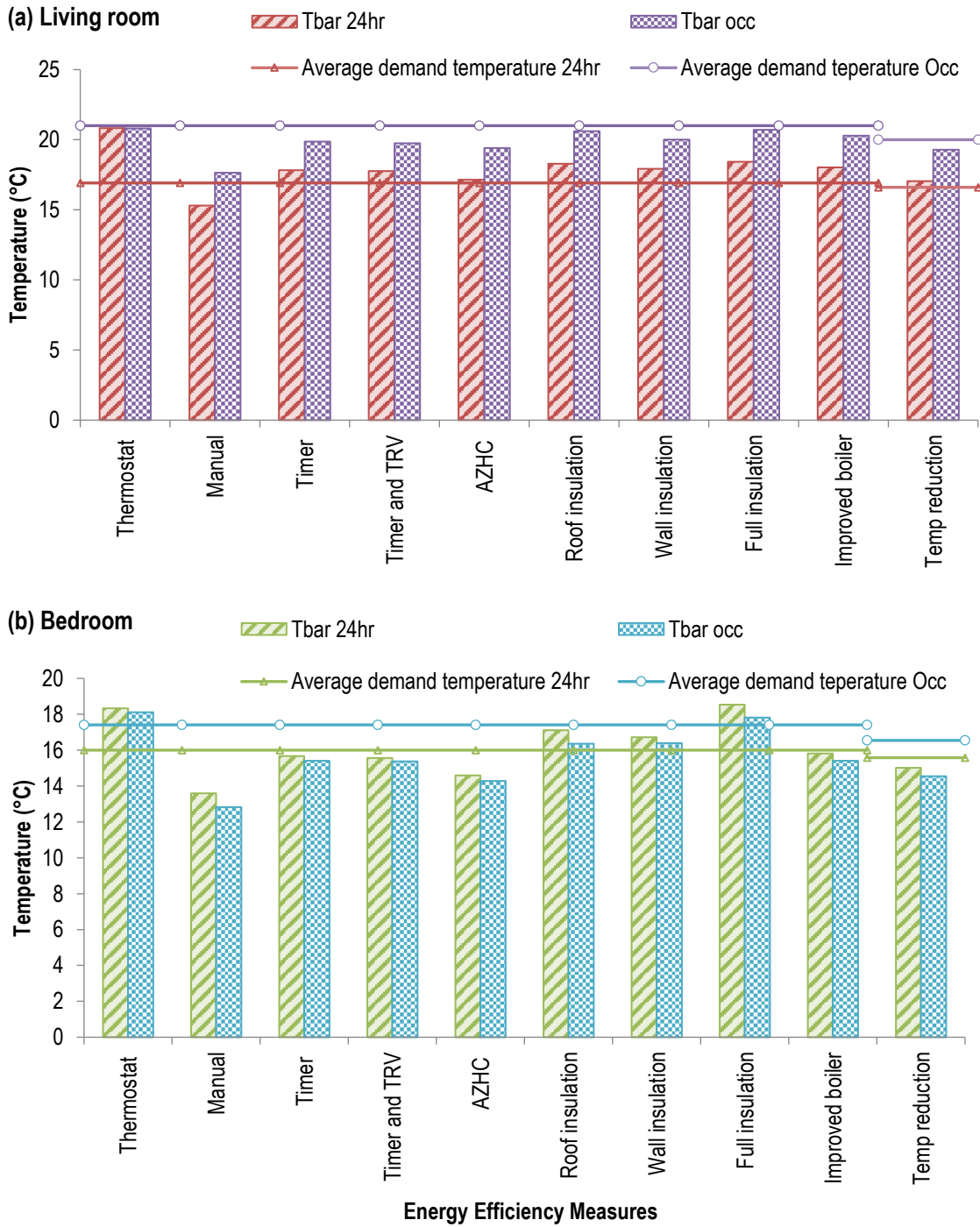
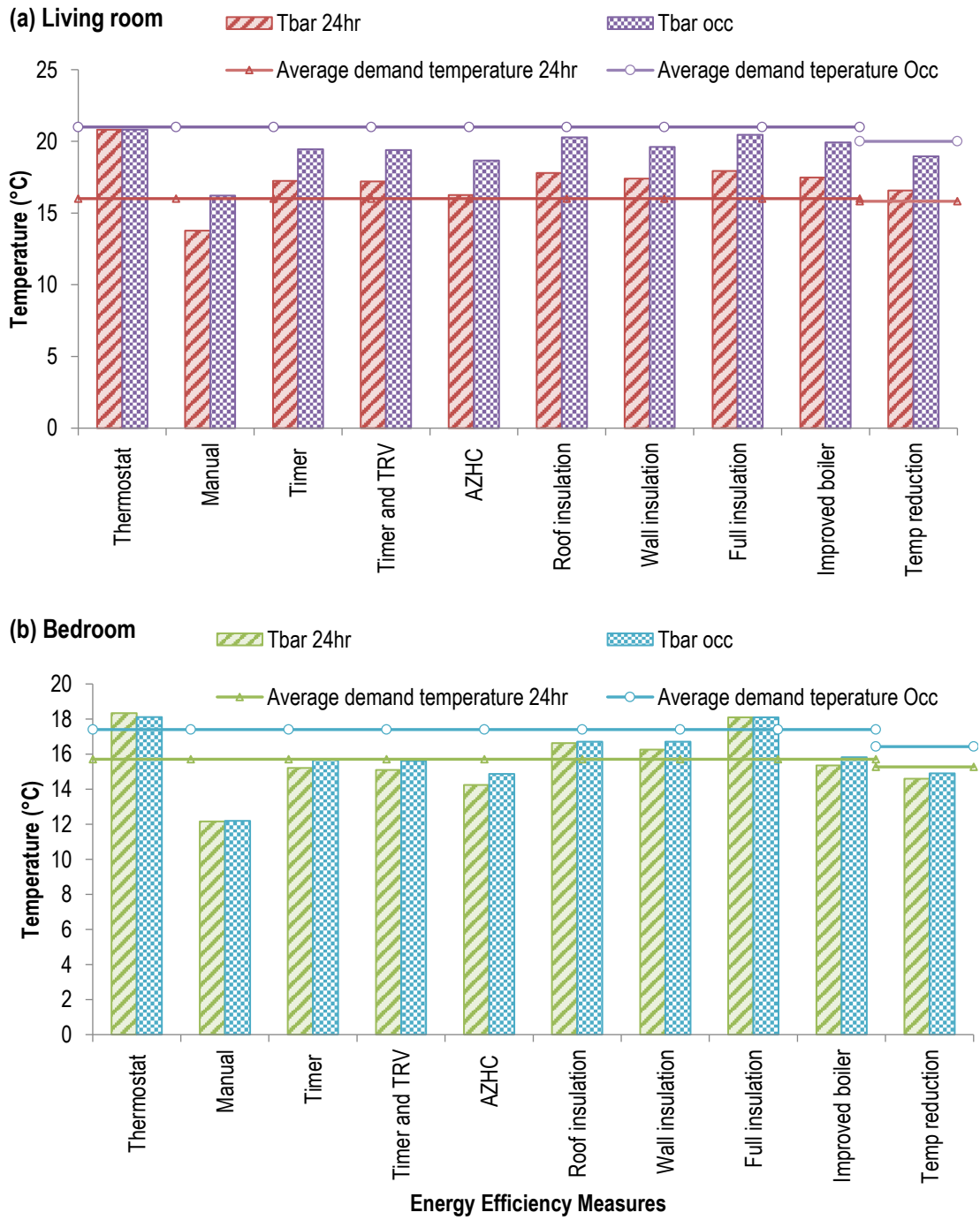
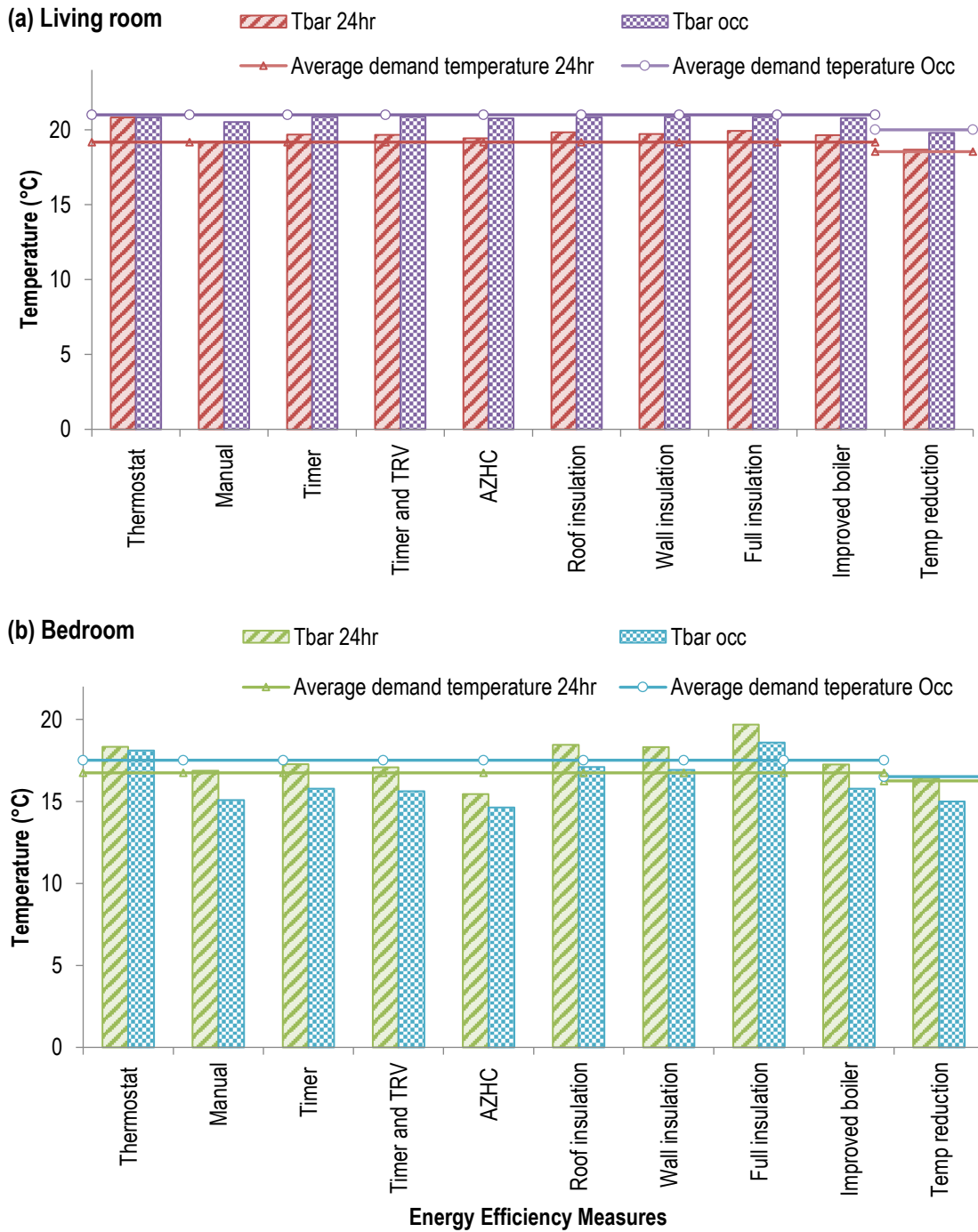


Figure 6-5 Average temperatures and average heated temperatures for Working Family occupancy pattern across the range of energy efficiency measures. (Notation: Tbar refers to  $\bar{T}$ )



**Figure 6-6** Average temperatures and average heated temperatures for Working Couple occupancy pattern across the range of energy efficiency measures. (Notation:  $T_{bar}$  refers to  $\bar{T}$ )



**Figure 6-7** Average temperatures and average heated temperatures for Daytime-present Couple occupancy pattern across the range of energy efficiency measures. (Notation:  $T_{bar}$  refers to  $\bar{T}$ )

To evaluate the average temperature metric, the results given by the overall average temperature metric ( $\bar{T}_{24hr}$ ) and average temperature during occupied time metric ( $\bar{T}_{occ}$ ) are compared. In the living room, when the  $\bar{T}_{24hr}$  metric is used, demand temperature is exceeded by the modelled average temperature for all EEMs in all three occupancy patterns with the exception of manual heating control in the working family and working couple

occupancy patterns. In contrast, for the  $\bar{T}_{occ}$  metric, thermostat only heating control is the only options to satisfy demand temperature for the working family and working couple occupancy patterns.

Compared to the living room, there is a smaller difference between  $\bar{T}_{24hr}$  and  $\bar{T}_{occ}$  and the respective demand temperatures in the bedroom. The modelled average air temperature falls below demand temperature in more cases for the bedroom than the living room; this is particularly true for control options, and demand temperature is met just by thermostat only control and full insulation.

As a comparison of EEMs, average demand temperature is met or exceeded by the thermostat only heating control case in living room and bedroom for all occupancy patterns. Across heating control options, manual control has the lowest levels of modelled average temperature in all cases except the bedroom of the daytime-present couple (Figure 6-7(b)) in which AZHC shows the lowest average temperatures. Insulation shows an increase of the modelled average temperature in the bedroom of each occupancy pattern to greater extent than in the living room, and conversely, heating controls are shown to perform better in the living room than the bedroom in all occupancy patterns. Improved boiler efficiency and temperature reduction show only a small increase in average temperature (as compared to their base case of timer control).

As a metric for comparing satisfaction of demand temperature across EEMs, average temperature is easier to calculate than other options and provides a single value for each EEM scenario which allows it to be used alongside other measures of EEM performance. However, the difference between  $\bar{T}_{24hr}$  and  $\bar{T}_{occ}$ , especially in the heating control options, suggest that the  $\bar{T}_{24hr}$  metric is insufficient to inform about the delivery of thermal comfort and that there is more to know about the patterns of temperature satisfaction.

To develop the metric further, a weighted average temperature for the house can be calculated to bring together the living room and bedroom values (and other rooms in the house as the metric is developed). The weighting factor over which average is taken will affect the results and three options are considered:

- Average by floor area: living room has a floor area of 20 m<sup>2</sup> compared to the bedroom floor area of 14 m<sup>2</sup> and values could be weighted respectively;
- Average by occupied time where all occupied time is included ( $T_{occ,all}$ ): values of occupied time vary for occupancy pattern and bedroom occupancy time includes the whole night (living room - working family (WF): 7hr, working couple (WC):

4.25 hr, daytime-present couple (DPC): 15hr; bedroom - WF: 10.5 hr, WF: 10.5 hr, DPC: 11 hr);

- Average by occupied time where only awake occupied time is included ( $T_{occ,awake}$ ): bedroom occupancy time includes only awake time and not time whilst occupancy are assumed to be sleeping (living room - WF: 7hr, WC: 4.25 hr, DPC: 15 hr; bedroom - WF: 1.5 hr, WF: 2 hr, DPC: 2 hr).

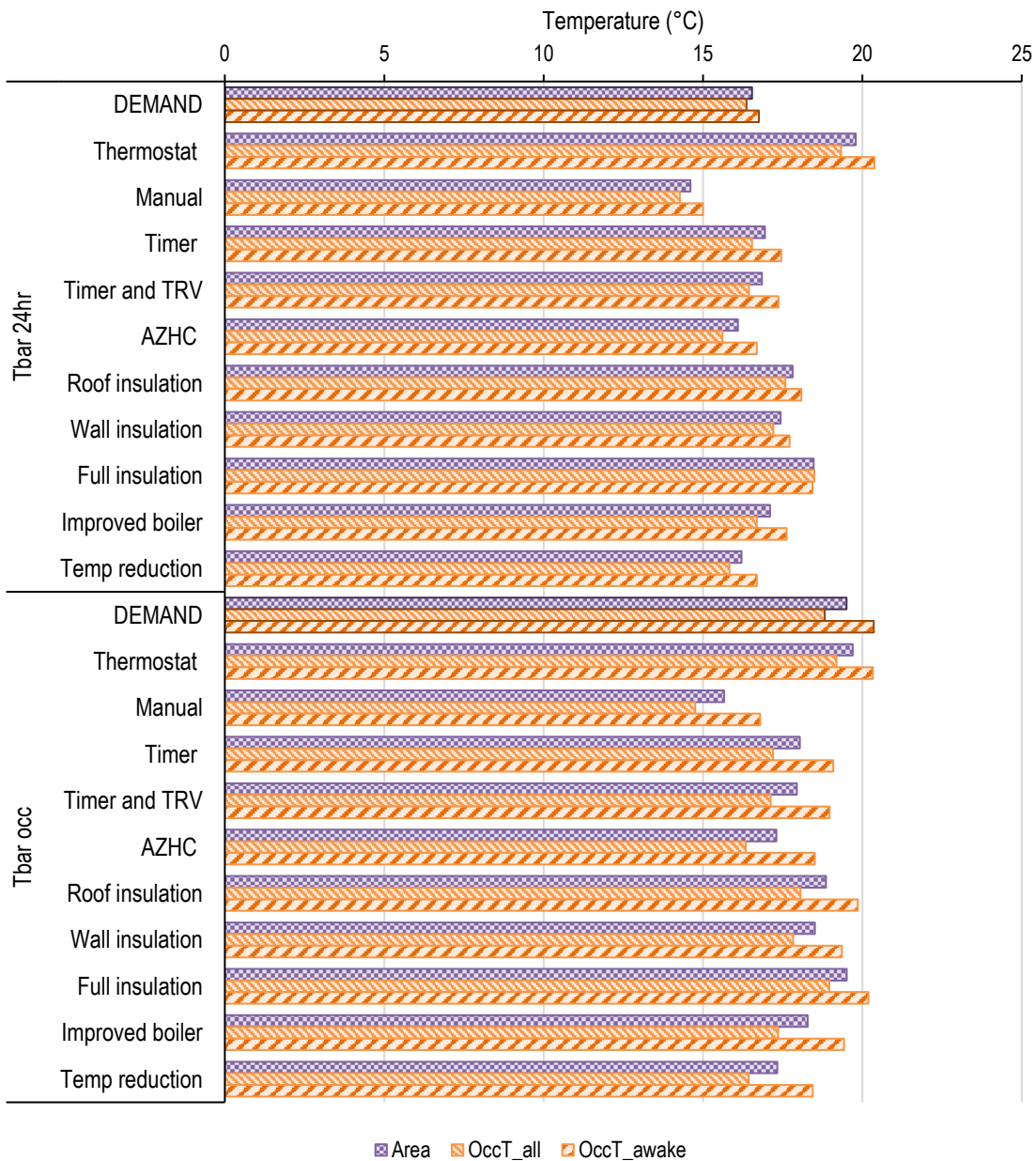


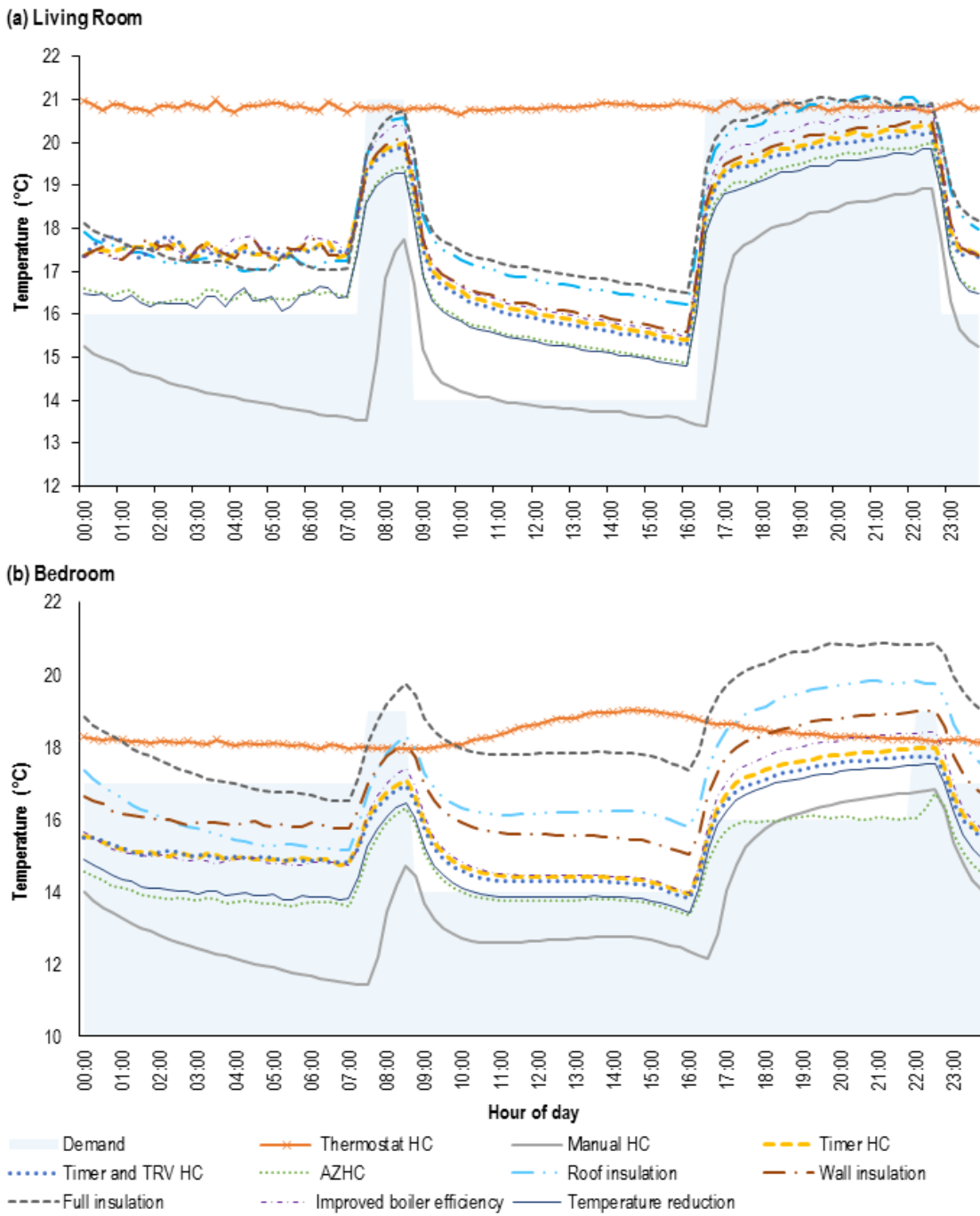
Figure 6-8 Weighted average comparison of working family occupancy pattern. (Notation:  $T_{bar}$  refers to  $\bar{T}$ )



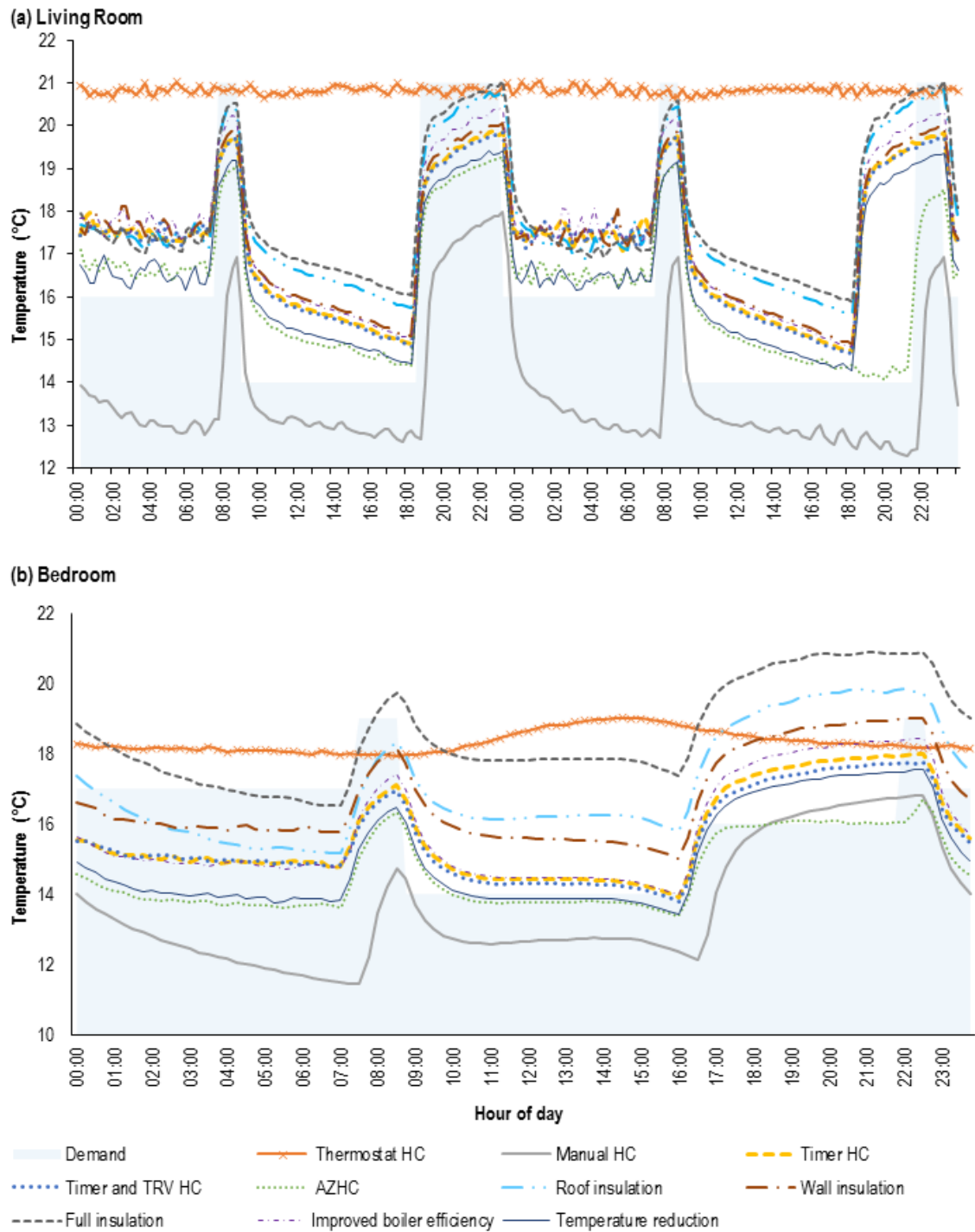
In comparing the three weighting factors, area weighting lies in the middle of the two occupancy time weighting factors. The difference between all occupancy time and occupied and awake time is greater for the  $\bar{T}_{occ}$  than the  $\bar{T}_{24hr}$  average metric. It is recommended that weighting average by floor area is not appropriate; if a household spends most of their time in a smaller room then it is appropriate that the thermal comfort metric would give this room a greater weighting than a larger but predominantly unoccupied room. In the case of these average temperature metrics, it is deemed appropriate that  $\bar{T}_{24hr}$  metric is weighted by the  $t_{occ,all}$  factor, as this therefore remains a low complexity metric to calculate and  $\bar{T}_{occ}$  is weighted by  $t_{occ,awake}$  as it is more representative of the use of the house and the comfort experienced by the occupants.

### 6.5.2 Averaged daily temperature profile

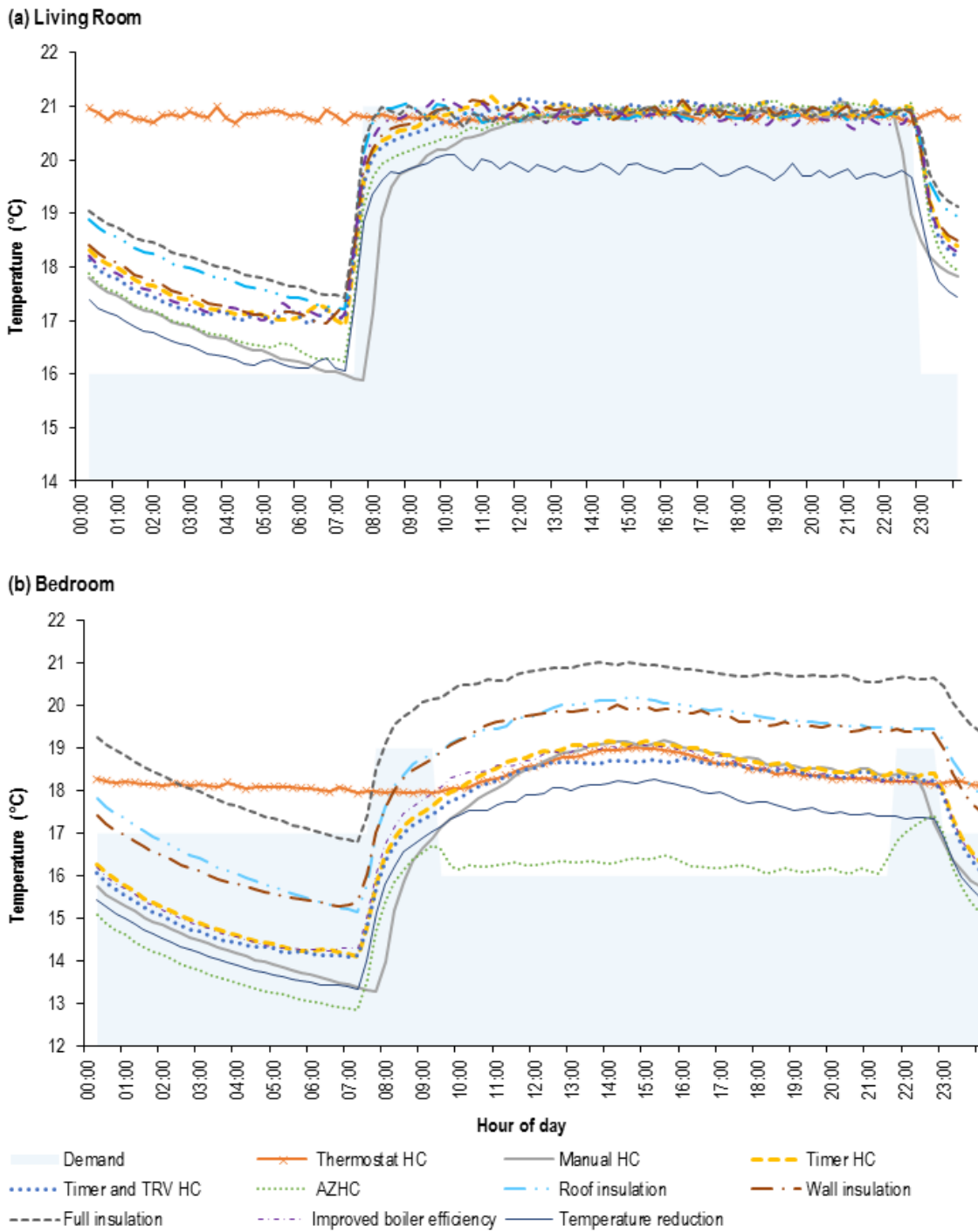
The averaged daily temperature profiles for working family, working couple and daytime-present couple occupancy patterns are presented in Figure 6-9, Figure 6-10 and Figure 6-11 respectively. Separate profiles are given for living room and bedroom. In all profiles, the modelled temperature for each EEM, as averaged at each time step over the modelled period, is displayed as a line, and the demand temperature (different to the set-point temperature used for the heating controls) is displayed as a shaded profile.



**Figure 6-9** Averaged daily temperature profile (averaged on each time step over a 30-day period) for Working Family occupancy pattern showing full range of EEM scenarios (HC: heating control) for (a) Living room internal temperature, and (b) Bedroom internal temperature



**Figure 6-10** Averaged daily temperature profile (averaged on each time step over a 30-day period) for Working Couple occupancy pattern showing full range of EEM scenarios (HC: heating control) for (a) Living room internal temperature, and (b) Bedroom internal temperature. Two day period is shown to represent the two daily patterns exhibited by the Working Couple occupancy pattern



**Figure 6-11** Averaged daily temperature profile (averaged on each time step over a 30-day period) for Daytime-present Couple occupancy pattern showing full range of EEM scenarios (HC: heating control) for (a) Living room internal temperature, and (b) Bedroom internal temperature

Temperature profiles show clearly the differences in the ability of EEMs to deliver the demanded temperature throughout the day. Thermostat only heating control delivers a constant temperature in the living room whether or not this temperature is required by household occupancy, and therefore shows a significant waste of heating energy. The delivered temperature is below the demanded temperature in the bedroom however, and this is likely to be due to the single house thermostat being located in the living room and there being no temperature sensor in the bedroom. AZHC is seen to deliver a closer match between the times at which increased heating is demanded and delivered within the bedroom, and therefore does not heat a room of the house which is not being occupied for an extended period of time. However, the shorter heating period means that the demanded temperature is not reached in most cases, particularly when the occupied period is short. The temperature profile figures indicate that insulation EEMs reduce the rate at which the internal temperature of a house cools down and therefore enables rooms to reach a desired temperature during heating periods more quickly. Heating control options in which the heating can commence thirty minutes prior to an occupancy period (timer, 'timer and TRV', and AZHC) show the temperature reaching the desired level earlier in the occupancy period and therefore delivering a higher level of thermal comfort. In Figure 6-10, the temperature profile displays the effect of the advanced heating control in responding to a variation in occupancy timing exhibited by the working couple occupancy pattern. In the second day period, it can be seen that in all other EEM scenarios the heating switches on at 18:00, and the house is therefore warm but unoccupied for three hours. The AZHC (and manual control) temperature profiles demonstrate the heating turning on only as required (for occupancy commencing at 21:30) and therefore the heating wastage is reduced.

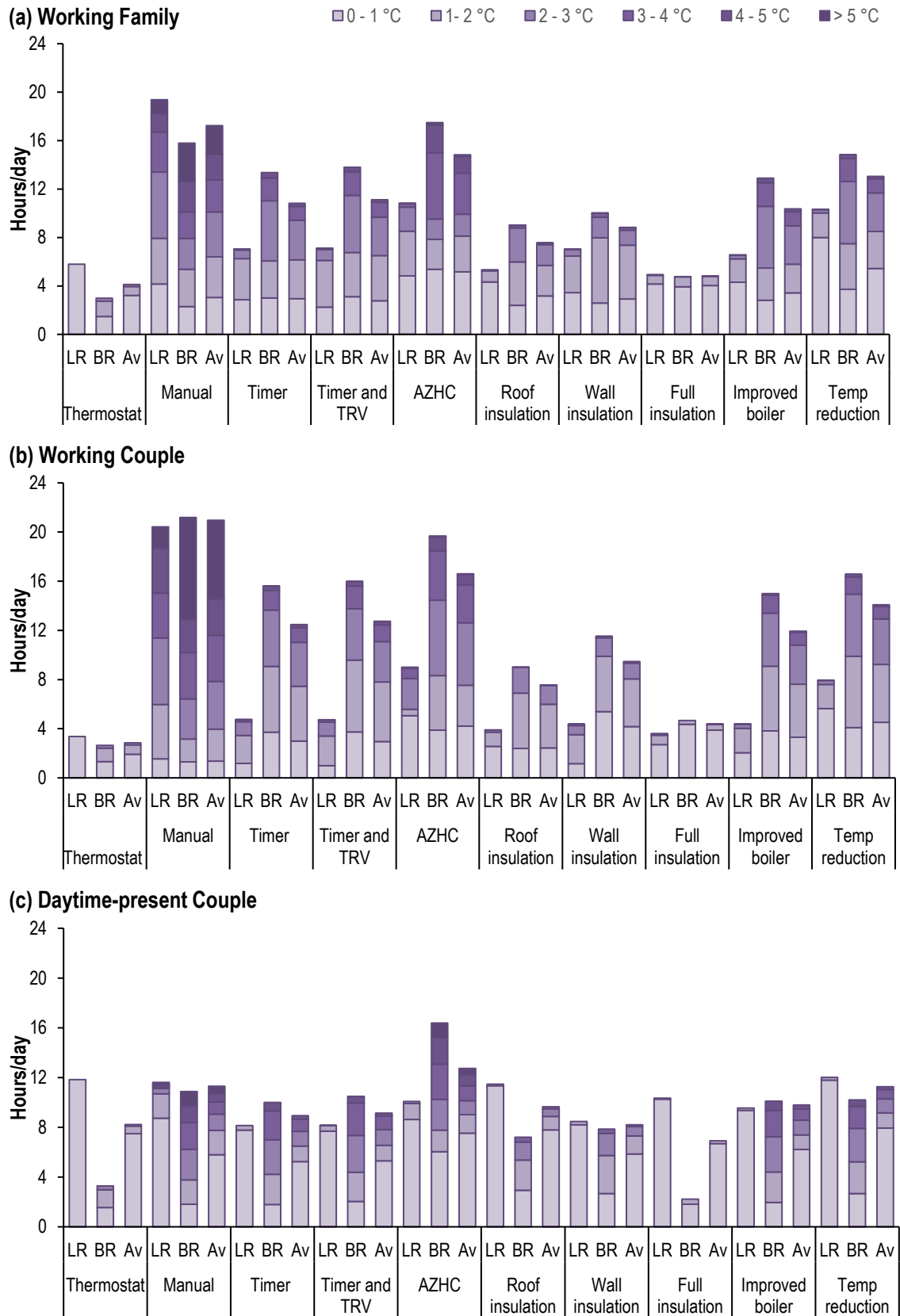
### 6.5.3 Temperature shortfall stack

Temperature shortfall stacks, as calculated using equation (6-3), are displayed in Figure 6-12 for living room and bedroom in all three occupancy patterns. An average is also displayed, weighted by the total occupied time in the living room and bedroom. The height of the bar reveals the averaged amount of time per day that the modelled internal temperature is below the desired temperature. Increasing temperature shortfall is indicated by increasingly darker colour shading.

The results of Figure 6-12 reveal that for all occupants the 'thermostat only' and full insulation cases deliver the highest level of thermal comfort. Manual heating control performs poorly, especially for the working couple and working family where the internal modelled temperature is frequently seen to be multiple degrees below the demand temperature. Temperature shortfall is generally higher in the bedroom than the living room

and this results in average values being increased. Roof or wall insulation show similar numbers of hours at 1 or 2 °C shortfall as timer, 'timer & TRV' and AZHC control, but the heating control options have additional hours at higher temperature shortfall.

The temperature shortfall metric allows for the magnitude of the difference between the internal modelled temperature and the demand temperature to be used to distinguish between EEMs by different types of people. For some occupants or households, a 1 °C shortfall will not affect their perception of comfort too greatly and therefore the first light coloured segment can be discounted from analysis. For others, even a 1 °C temperature shortfall would be uncomfortable and therefore the whole bar would be considered in a comparison of EEMs. The temperature shortfall metric provides additional information beyond the temperature profile as it presents a summation based on data from throughout the modelled period; in the case of full insulation, the temperature profiles in Figure 6-9, Figure 6-10 and Figure 6-11 appears to show that the demand temperature is met throughout the day, whereas the temperature shortfall shows that the demand temperature is not met from 3.5 hr/average day (for working couple) to 12 hours/average day (Daytime-present couple) and therefore the profile average is concealing some information on this.



**Figure 6-12** Temperature shortfall stacks for living room (LR), bedroom (BR) internal temperatures, and a weighted average of the two modelled rooms (Av) for (a) Working family, (b) Working couple, and (c) Daytime-present couple

### 6.5.4 Heating comfort gap

The HCG is a single value metric by which EEMs can be compared. These values are shown in comparative bars in Figure 6-13. The bars of HCG in Figure 6-13 provide similar information to the temperature shortfall stacks in Figure 6-12 but allowing more definitive comparison of the extent to which thermal ‘discomfort’ is alleviated by each EEM.

The main benefit of condensing temperature shortfall into a single metric is to enable a tentative quantitative comparison of satisfaction of thermal comfort with other co-benefits, such as heating energy demand, as shown in the scatter plots in Figure 6-14, Figure 6-15 and Figure 6-16 for the Working Family, Working Couple and Daytime-present Couple occupancy patterns respectively. A comparison of heating energy demand values calculated by the heat balance model used in chapter 5 and the enhanced model used in the present chapter are shown in Figure D-2 in Appendix D.2. The relative energy consumption levels show a fairly close match between the two models. The main difference is the heating demand values calculated for insulation measures: wall insulation is calculated lower in the heat balance model, whilst roof and full insulation are calculated lower in the enhanced model. In the scatter plots of Figure 6-14, Figure 6-15 and Figure 6-16, the strongest options for EEMs are those closest to the (0,0) origin.

The HCG is smaller in the DPC case, particularly in the living room. This may be because a desired temperature can be met more easily for a longer heating period. The HCG is higher in the bedroom than the living room for all occupancy patterns and this can be attributed to the fact that the heating is primarily controlled by the living room thermostat and therefore the bedroom heating is not always able to react when the temperature drops below the set-point temperature. The best performing EEMs are thermostat only and full insulation. For thermostat only control, the heating is continually maintaining a high temperature and therefore is most likely to meet the temperature demand. Full insulation retains heat and therefore the internal temperature is able to increase more rapidly in response to a heating period. Manual heating control performs most poorly as the heating is switched on at the beginning of an occupied period only and has less time to cause a temperature increase. With the exception of thermostat only and manual control, heating control performs better in the living room than the bedroom, and the weighting results in this causing a poorer performance in the averaged metric. The poorer performance of the heating control in the bedroom is due to the position of the primary thermostat controller in the living room as described above. Boiler improvement and temperature reduction are shown to have little effect on the HCG, but even with a 10 % comfort taking, the boiler delivers energy savings. For a change in heating controls from manual control, the heating energy demand is calculated to exhibit an increase of 6 to 34 % but this comes with a



reduction of HCG of 55 to 280 %. AZHC is calculated to enable 3 - 7 % heating energy demand savings compared to timer and TRV only, but at the expense of around 50 % increase in HCG.

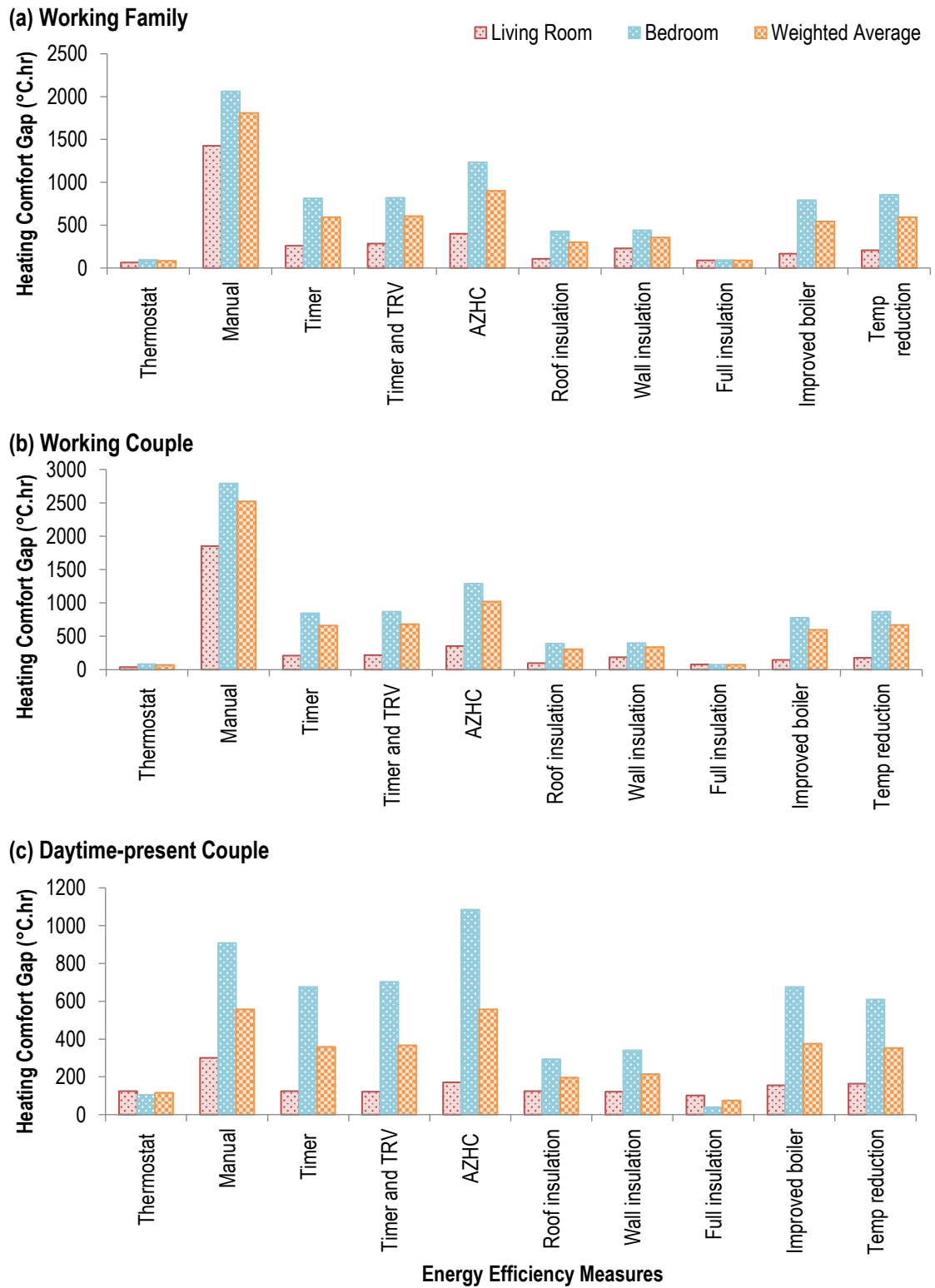
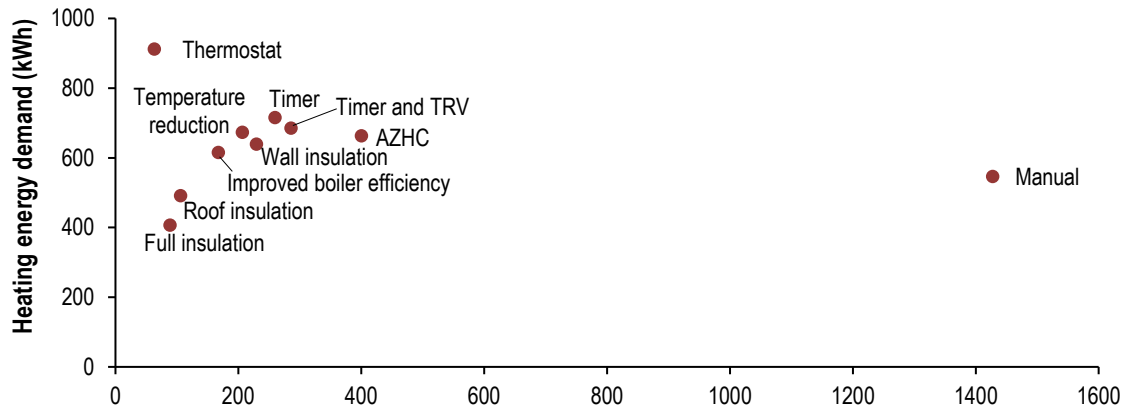
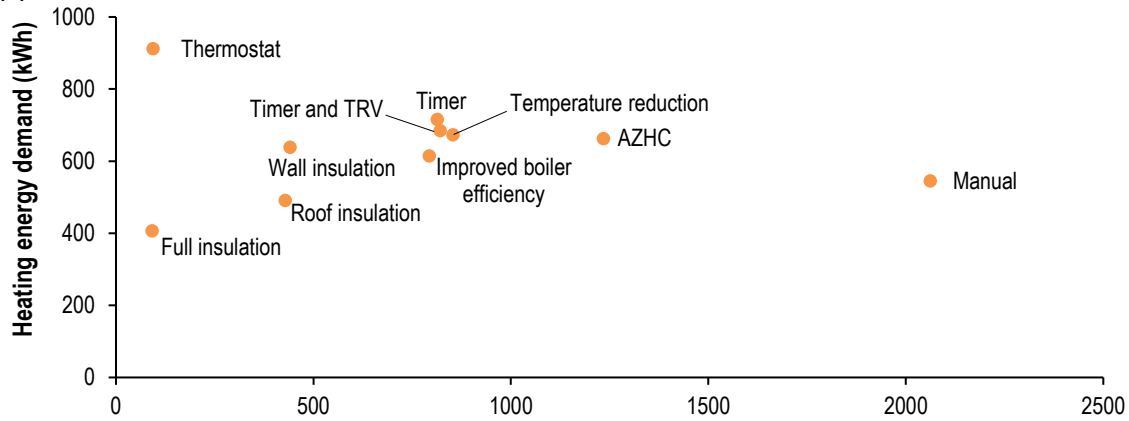


Figure 6-13 Heating Comfort Gap factor for each energy efficiency measure shown for living rooms and bedrooms for (a) Working Family, (b) Working Couple, and (c) Daytime-present Couple Occupancy Patterns

(a) Living Room



(b) Bedroom



(c) Weighted average

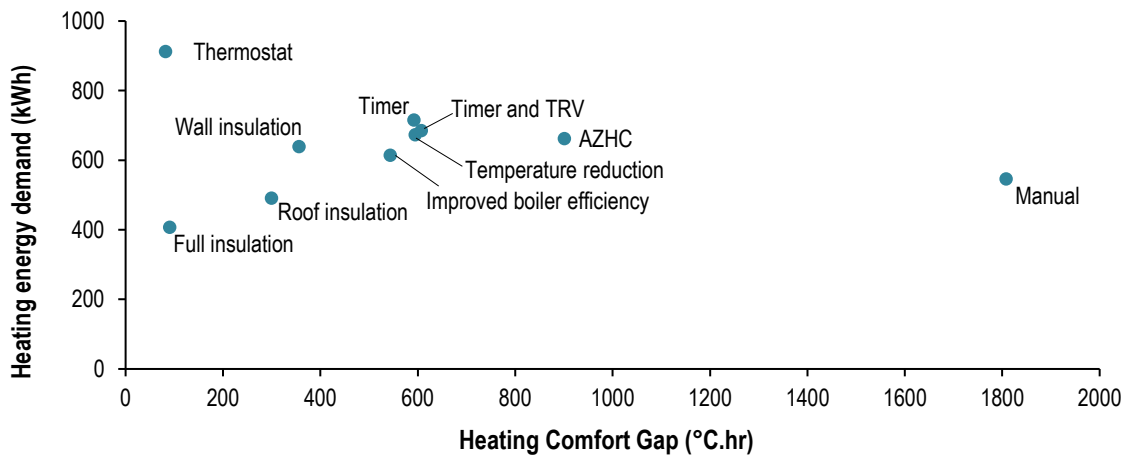
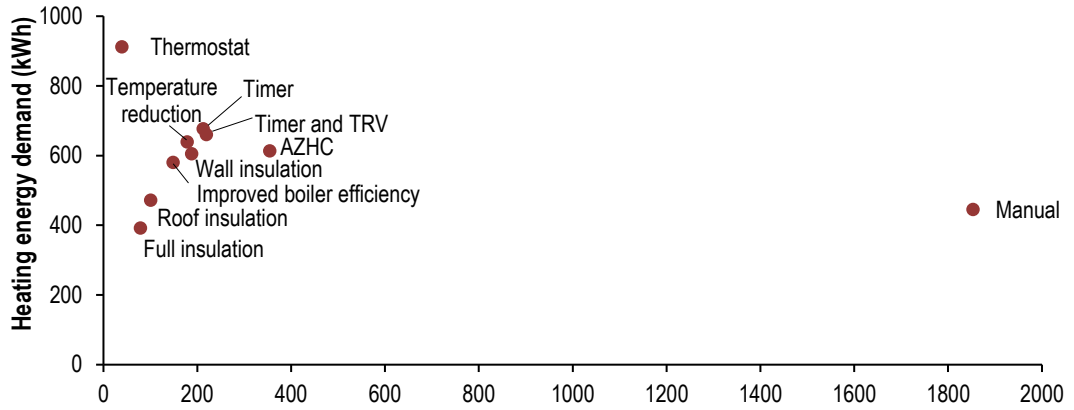
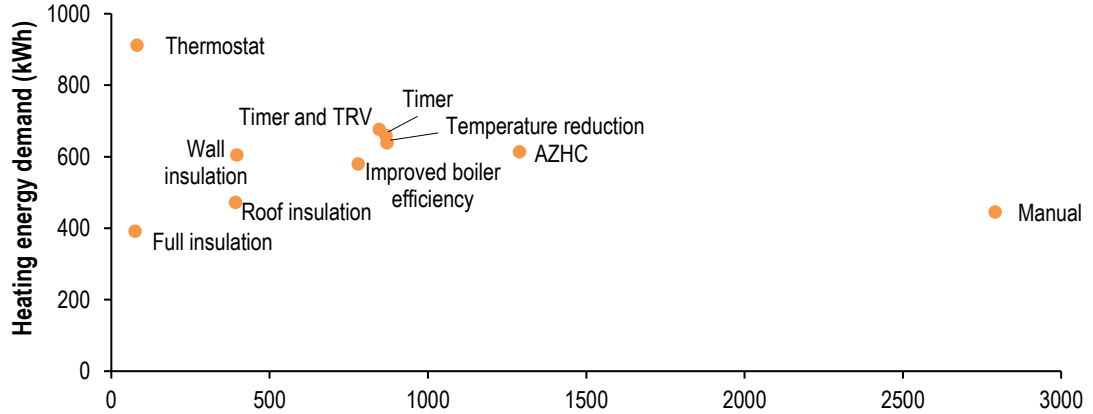


Figure 6-14 Heating Comfort Gap vs Heating energy demand scatter chart for full range of EEM scenarios for Working Family occupancy pattern in (a) living room, (b) bedroom, and (c) weighted average

(a) Living Room



(b) Bedroom



(c) Weighted Average

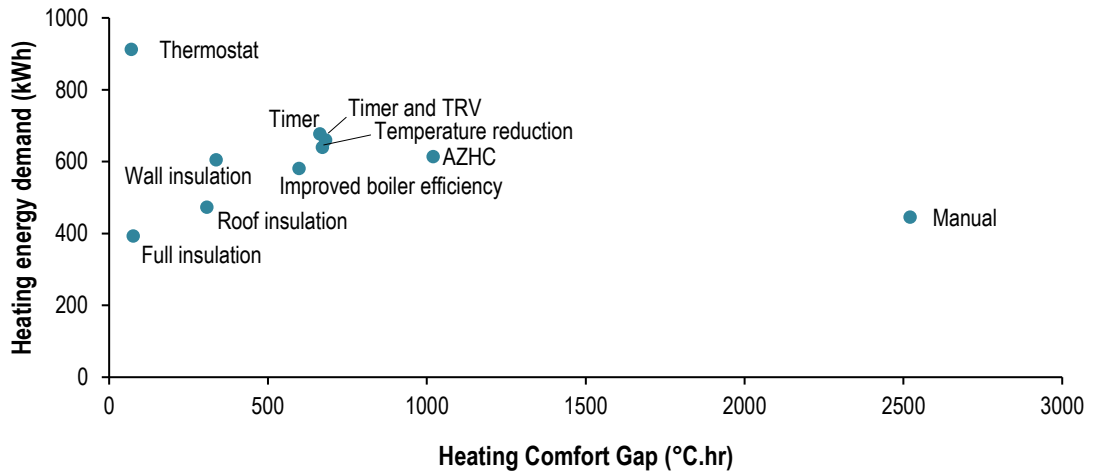
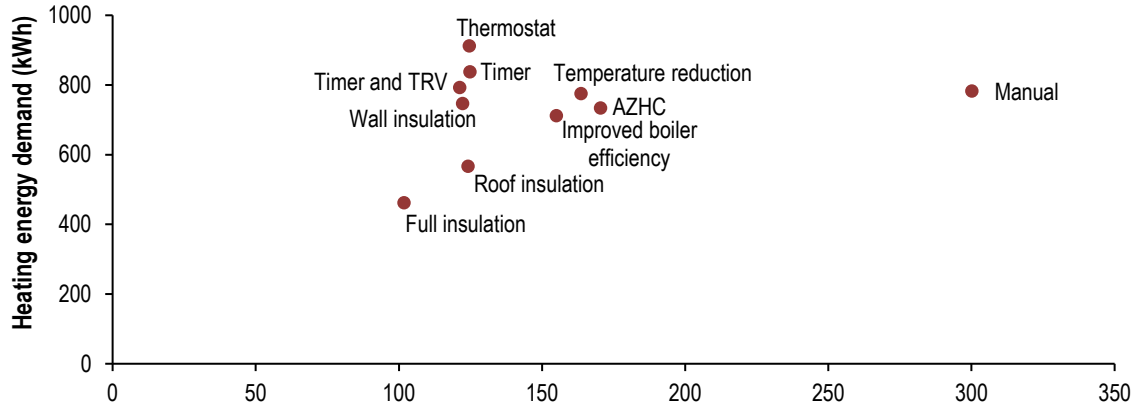
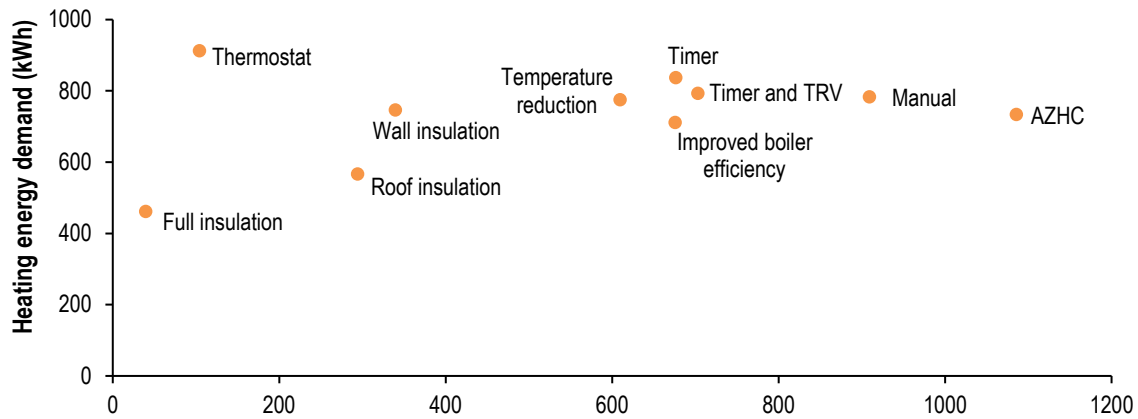


Figure 6-15 Heating Comfort Gap vs Heating energy demand scatter chart for full range of EEM scenarios for Working Couple occupancy pattern in (a) living room, (b) bedroom, and (c) weighted average

(a) Living Room



(b) Bedroom



(c) Weighted average

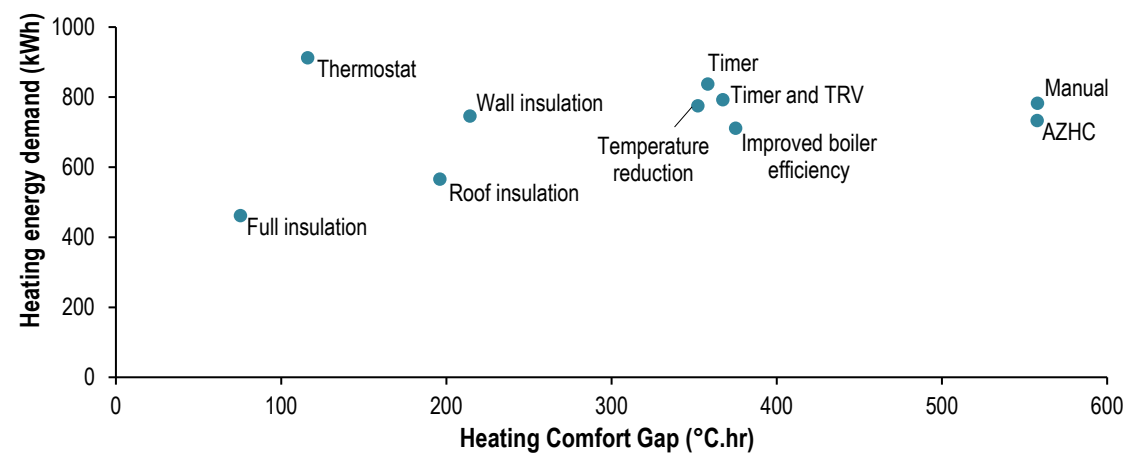


Figure 6-16 Heating Comfort Gap vs Heating energy demand scatter chart for full range of EEM scenarios for Daytime-Present Couple occupancy pattern in (a) living room, (b) bedroom, and (c) weighted average

## 6.6. Discussion

### 6.6.1 Thermal comfort delivery metrics

Four metrics for the measurement of thermal comfort delivery have been presented in this chapter; average temperature (both for the whole time period and for occupied time only), temperature profile (averaged for each time step), ‘temperature shortfall stack’ and ‘heating comfort gap’ (HCG). Each option has strengths and weaknesses which would dictate whether they could be developed further into a tool for building models and energy efficiency decisions.

A metric of average temperature is the most straight forward metric to calculate, and as a single value it makes comparison between different EEMs more straightforward. However, there is a discrepancy between the results if a total average temperature ( $\bar{T}_{24hr}$ ) or average temperature of occupied time only ( $\bar{T}_{occ}$ ) approach is used. Modelled average temperature meets or exceeds demand average temperature in more cases using  $\bar{T}_{24hr}$ , suggesting that  $\bar{T}_{occ}$  should be calculated to provide best information about the delivery of thermal comfort (although it is less trivial to compute). Even if a modelled average temperature meets the demand average temperature, it does not go so far as to provide full information about how well that EEM enables thermal comfort to be satisfied. Meeting an average temperature can be achieved either by consistently maintaining a desired temperature, or by cycling above and below the desired temperature; a suitable metric should be able to tell the difference and a house showing the latter would be seen as falling short of meeting the desired comfort temperature in other metrics.

Temperature profile provides a clear indicator of how demand temperature is met over an average day for each EEM, giving information about the responsiveness of EEMs and the extent of any temperature shortfall. By averaging the data over each time step, the EEMs can be compared with greater clarity than if an extended period is displayed (Figure 6-1(a) made analysis difficult with only 10 days displayed). In order to overcome the inevitable loss of detail from averaging over each time step, averages could be made over simulation periods which share similar conditions such as averaging for particularly cold weather periods and warm periods separately. Temperature profile is less affected by the demand temperature chosen in different rooms throughout the day. The modelled temperature profile could also be compared to a broader range of temperatures during occupied periods; the width of the acceptable temperature range would depend on the sensitivity to temperature of the occupant in question.

In the temperature shortfall stack metric, the EEMs can be compared according to the time for which the modelled internal temperature is below demand comfort temperature (height of bars) and how large this shortfall is (darkness of shading of bar segments). Single bars allow the comparison of multiple EEMs and rooms of the house on the same graph. By converting total hours over the modelled period to averaged hours per day, the results become a more meaningful model output as it is easier to interpret temperature shortfall time relative to a proportion of a day rather than as an abstract large number. The results of the temperature shortfall metric are very sensitive to the choice of comfort temperature used in the model and therefore it is important that this value is appropriately chosen to suit the occupants in each analysis.

The HCG is a relatively novel metric which represents the extent of the temperature shortfall in time and magnitude over any time scale. The HCG metric easily enables comparison with other co-benefits, such as energy demand, via a scatter graph (as in Figure 6-14, Figure 6-15 and Figure 6-16), allowing the satisfaction of thermal comfort to be taken into consideration alongside other factors in decisions regarding energy efficiency recommendations.

Beyond the measurement of heating thermal comfort, the temperature shortfall stack and HCG could be further developed and inverted to measure the temperature overshoot (time for which a space is warmer than the desired temperature). Measuring overshoot could provide information about the potential to shorten a heating period with more advanced control. However, analysis must be sensitive to the fact that a well-insulated house can be expected to have a large overshoot of a high temperature following a heated occupied period as heat is held in the building long after the end of the heating period, but this would not be an indicator of high energy demand; analysis would need to be sensitive to the fact that high values of overshoot should not be interpreted as poor heating management in all cases. Temperature overshoot could also be used as a metric for overheating, but the upper bound of the demand temperature would be higher than the demand temperature used within the present work and would represent a range of maximum acceptable temperatures. This metric could be used as a 'cooling comfort gap' for the time when the space is uncomfortably hot (especially in warmer climates).

Overall, the HCG metric and the average temperature profile plot are recommended as the best ways of measuring and comparing the delivery of thermal comfort for different EEMs. Temperature profile presents a detailed visual comparison of how well EEM can meet temperature demand, including the option of displaying acceptable comfort temperature as a range rather than a single point. By presenting an extended period as an averaged day, the resolution of the figure is improved and allows comparison between EEMs, despite a

loss in detail over the period. The HCG metric, similar to the Weighted Discomfort Time measure (European Standard 2006) is a way of condensing the temperature profile into a single metric, allowing it to be used in multi-criteria analysis alongside energy savings in recommendations for energy efficiency work. HCG is sensitive to the value of temperature demand and therefore care is required that a suitable value is chosen for any particular situation.

### 6.6.2 Comparison of energy efficiency measures

Through the evaluation of four metrics for thermal comfort delivery, results have been generated which allow comparison of ten different states of EEMs. The results of the four metrics are in broad agreement, and vary across occupancy patterns and within the living room and bedroom.

In all cases (for all occupancy patterns in both living room and bedroom), a constant thermostat setting with heating on continually is shown to be the most effective way of ensuring temperature demand is met. However, this heating option was also revealed to have a high heating energy demand (Figure 6-14, Figure 6-15 and Figure 6-16) and the temperature profiles of Figure 6-9, Figure 6-10 and Figure 6-11 show that much of the heating is wasted with heating being on at a high level whilst the house or room is unoccupied or a lower temperature is required. Manual heating control was shown to perform most poorly in the majority of cases, due to the occupied rooms having limited time to warm up. However, it is unrealistic that manual control would perform as modelled as occupants would intervene before the average temperature truly falls to around 15 °C. The temperature profiles of Figure 6-9, Figure 6-10 and Figure 6-11 shows that with manual control the temperature remains far below the demanded comfort temperature in all cases; it is expected that household occupants would leave the heating on for longer periods to warm the house up further in reality, unless they are facing the challenges of fuel poverty.

Beyond thermostat only heating control, all metrics indicate that in the living room, heating controls deliver a significantly higher level of thermal comfort in the living room than in the bedroom. The poorer performance of the heating controls in the bedroom can be attributed to the main temperature sensor being based in the living room, and the bedroom having no direct control over when the heating system is on. It is an important finding that heating controls which are currently common are failing to deliver thermal comfort in bedrooms, and potentially other rooms outside of the living room (or location where the main heating control and central thermostat is based). Some advanced heating systems do enable all room temperature sensors to communicate with the boiler and would be expected to improve results, but these are currently less commonly available

commercially at the time of writing. Another control improvement which could enhance thermal comfort delivery is the capability of controls to learn how long it takes to heat up a room for a given outside air temperature. Such functionality could enable heating to automatically switch on with sufficient time to ensure comfort temperature is reached by the beginning of an occupancy period. TRNSYS has a thermostat unit which represents proportional-integral-derivative (PID) control that allows for temperature control based on past and future error and could enable a better option for advanced heating controls.

Insulation EEMs have shown to perform well and deliver generally high levels of heating thermal comfort. Full insulation has consistently delivered highest levels of heating thermal comfort alongside 'thermostat only' heating control. Throughout all cases, roof insulation has been seen to perform marginally better than wall insulation. Insulation measures are particularly strong performing in the bedroom where other EEMs perform less well. As can be seen in Figure 6-14, Figure 6-15 and Figure 6-16, insulation measures are commonly the EEMs closest to the (0,0) origin and therefore perform well in both low heating energy demand and low HCG.

The effectiveness of improved boiler efficiency can be assessed by making comparison to the timer only control option. Improved boiler efficiency of 17 % is represented in the model by allowing a comfort taking effect such that the improved boiler has 10 % more power. The extent to which boiler improvement delivers thermal comfort improvements varies across the occupancy patterns and rooms; the reduction in the HCG is greater in living rooms than in the bedrooms, and this reduction is three times greater in the DPC occupancy pattern than for the WC occupancy pattern.

In evaluation of temperature reduction (lower heating set-point) as an EEM, comparison is also made to the timer control only. The scatter plots of Figure 6-14, Figure 6-15 and Figure 6-16 show a consistent heating energy saving of around 6 % but HCG value is not consistently lower; in the WF and WC occupancy patterns the effect ranged from a 10-14 % HCG reduction in the living room to a 6-8 % HCG increase in the bedrooms. The effect was greater for the DPC occupancy pattern with HCG reduction of 17 % and 41 % in the bedroom and living room respectively. At a lower set-point temperature, it is expected that the house would be able to reach demand temperature more easily and therefore it is surprising that in some cases a reduction is seen in how well the house meets the demanded comfort temperature.

The results of this chapter provide insight into the suitability of EEMs for household archetypes with a motivation of 'comfort'. Recommendations are that EEMs of improved boiler efficiency, insulation (wall or roof) and heating control using TRVs are suitable for



delivering improved heating thermal comfort. Service control using AZHC and decrease in service level (temperature reduction) are not deemed appropriate.

### **6.6.3 Evaluation of building energy modelling approach**

For the calculation of thermal comfort delivery in this chapter, it is necessary that the model can generate a realistic internal temperature profile. Comparison of the modelled temperature profile generated by the heat balance model used in Chapter 5 with a measured indoor temperature profile taken from literature (Beizaee et al. 2015) showed that an improved modelling approach was required. Consequently, an enhanced model has been developed for use within the present chapter which was shown in Figure 6-4 to better replicate the internal temperature profile of the measured data for a real house. The enhanced modelling approach puts additional requirement onto the modelling tool used for comparison of EEMs, but this chapter has demonstrated the benefit that such an upgrade could enable in terms of measuring the co-benefits for EEM and predicting how they will affect the delivery of energy service of heating thermal comfort.

The modelling method could be further enhanced with additional validation between modelled results and real measurements of internal temperature, particularly for different occupancy patterns and levels of insulation. Rigorous validation of the building model has been beyond the scope of this work, which has been primarily focussed on evaluating metrics of delivered thermal comfort which could be included in BEM outputs alongside energy savings. To further improve the BEM, aspects such as inter-room air-flow and internal heat gains could be included.

### **6.6.4 Representation of real people in analysis**

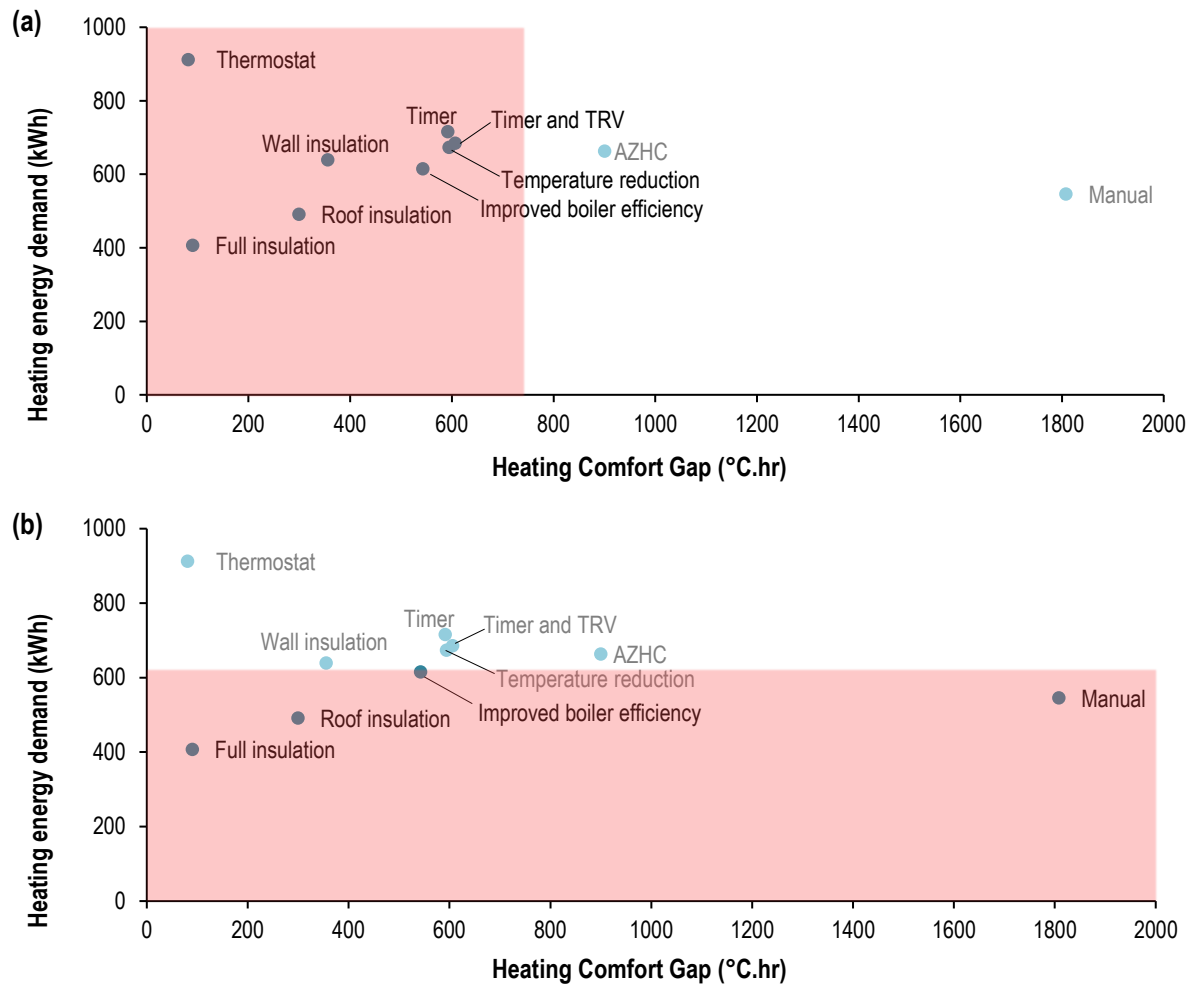
In this chapter, three occupancy patterns have been investigated in order to compare the effects of EEMs on a range of household types. The variation in results between different occupancy patterns demonstrates the importance of including sufficient detail about occupants when modelling specific cases. However, variation in household energy use goes beyond occupancy pattern and therefore other sources of variation should be included in building modelling to continue to increase the accuracy of results.

In all metrics, the calculation of thermal comfort delivery is very sensitive to the definition of the demand temperature and therefore the results are expected to be different for a household which favours lower or higher internal temperatures. The temperature at which people are thermally comfortable will depend on many reasons such as health, physiology, culture and habit. Identifying an accurate value for comfort temperature is difficult as there has commonly been found to be a discrepancy between qualitative and quantitative studies

into what people say they want from their heating and what actions they actually display (as discussed in section 2.3.2). The 'comfort temperature' may be better replaced by a range of temperature which would be considered comfortable by household occupant (e.g. a band of  $21 \pm 0.5$  °C); the level and width of this range would vary for different people. Alternatively, the comfort temperature could be varied throughout the modelled period based on a combination of adaptive model (to compensate for external temperature) and heat balance model (e.g. Predictive Mean Vote (PMV)) (to adjust for metabolic rate and clothing level of people) approaches.

Another effect of household intervention in energy efficiency work is the rebound effect of comfort taking, whereby higher internal temperatures rather than energy savings are the outcome following the introduction of EEMs. To some extent, this work is based upon the assumption that each EEM may lead to an improvement in thermal comfort and therefore some degree of comfort taking. A direct comfort taking effect is included in the modelling of improved boiler efficiency EEM, with a portion of energy saving potential compromised by a rise in heating power in each room. The effect of this comfort taking was a lower energy saving but improved delivery of thermal comfort. Similar effects could be investigated for other EEMs such as raising the temperature set-point of heating controls following the installation of energy efficiency improvements. For some households such as those in fuel poverty, whose heating behaviours may be dictated by what they can afford rather than choice, an increase in comfort is arguably more important than energy savings and by quantifying the benefit to the household of improved thermal comfort, these co-benefits could be brought into housing energy efficiency policy.

The work in this chapter has improved the potential of BEMs to match EEMs to households depending on their preferences or constraints, allowing unsuitable EEMs which are likely to underperform to be eliminated from consideration. A practical application could be for acceptable zones to be identified on the energy demand-HCG scatter plots, as shown in Figure 6-17. Figure 6-17(a) represents a display of results for a household whose occupants are motivated by comfort or sensitive to temperature and therefore could have a HCG threshold. Figure 6-17(b) represents a display of results for a household for whom energy cost or environmental impact are greater concerns and therefore would have a threshold of energy demand. The position of these thresholds would depend on the individuals and further empirical data collection would be able to inform the acceptable level of each threshold for different types of people.



**Figure 6-17** Illustration of zones of suitability where the shaded zone represents the EEMs which would be more suitable for (a) a household motivated by comfort or sensitive to temperature, and (b) a household motivated by cost or environmental impact

## 6.7. Conclusion

The aim of this chapter has been to demonstrate the potential for generating an indicator for thermal comfort satisfaction within BEM which could be used alongside energy demand and energy savings calculations to inform decision makers about the best options for delivering low carbon thermal comfort as an energy service. To achieve this, the building energy model is required to calculate internal temperature more accurately than a typical heat balance model and this was achieved through the modular functionality of TRNSYS using additional radiator and thermostat units. In its present form, there are still differences between the temperature profile calculated by the model and a profile measured in a real house, as shown in Figure 6-4, but the enhanced model developed in this chapter

has been sufficient to perform the analysis required for the present work; further development could enable the model accuracy to improve and strengthen the results of the work.

From the results of this chapter, thermal insulation is shown to lead to greatest satisfaction in thermal comfort as a steeper temperature rise was achieved and a higher temperature was reached during the occupied periods as shown in the temperature profiles in Figure 6-9, Figure 6-10 and Figure 6-11. Heating controls (Timer and TRV and/or AZHC) were able to successfully achieve heating energy demand reduction and improved thermal comfort delivery in some cases (in the living room for the Working Family and Working Couple occupancy patterns), however they were less effective in other cases, particularly in the temperature delivery to the bedroom. Manual heating control was commonly the least successful option for thermal comfort delivery, but did enable low values of heating energy demand. If controls do not deliver acceptable levels of service they will not be adopted, and conversely, if new controls are liable to increase the energy use, the aims of reducing domestic energy consumption are not achieved. Both factors are important when considering making improvements to home heating systems. For true advanced heating controls, the system should be able to learn how long it takes to heat the space for a given outside air temperature and therefore the variation between desired temperature and recorded temperature would be reduced.

Overall, it is recommended that both average temperature profile plots and the HCG metric are incorporated into BEMs. Temperature profile plots give a detailed visual comparison of EEMs' ability to deliver a comfort temperature as well as information about responsiveness. The heating comfort gap (HCG) represents a relatively novel factor for comparing the delivery of thermal comfort alongside energy savings. If an enhanced building modelling approach were to be incorporated into BEMs for use to inform energy efficiency decisions, the co-benefits of EEMs, beyond only energy savings, could be considered when analysing retrofit options. The quantification of the delivery of thermal comfort could also go towards enhancing the information gained in energy efficiency assessments such that improvements in the delivery of thermal comfort could be valued alongside energy savings.

# Chapter 7 Discussion

## 7.1. Introduction

This discussion chapter will provide further exploration of new insights, limitations and broader applications of the work within this thesis, considering in turn technology assessment (section 7.2), energy service theory (section 7.3) and building modelling (section 7.4). Due to the integrative approach of the analytic framework, there will necessarily be some overlap between these topics. The extent to which the questions arising from the analytic framework have been answered will be covered in the conclusion chapter.

## 7.2. Technology assessment

The assessment of technologies carried out in Chapters 4, 5 and 6 provide a new analysis of energy efficiency technologies and measures (EEMs) used for delivering heating thermal comfort (HTC). These findings are herein consolidated followed by a consideration of data availability as a limitation of the present study and finally focus is given to which further technologies could be included for wider application.

### 7.2.1 Comparison of energy efficiency technologies and measures

Four approaches to lower carbon energy service delivery have been covered in the present work and each has shown benefits in certain cases over others. The analysis of Chapter 4 shaped the methodology of how technologies could be evaluated. Rather than assessing how each technology can individually deliver a micro 'unit' of energy service, the contribution of each measure has been compared for reducing energy required to deliver the service demanded in a defined situation. This finding led to three hypothetical occupancy patterns being considered in the analysis of Chapter 5, based on typical

households in the UK where energy saving potential of each EEM was calculated. These measures were then compared based on their delivery of HTC using visual and numeric metrics of thermal comfort delivery in Chapter 6.

An overview of each of the four EEMs is now presented, including their energy saving potential and delivery of heating thermal comfort, the ability of the model to produce results similar to those measured in other studies, the suitability of each EEM to different types of occupancy patterns, and recommendations for policy support.

### *7.2.1.1 Conversion device*

In the majority of the present study, a gas boiler was considered as a conversion device for converting fuel to heat within UK homes. The key parameter of the boiler was the efficiency of the conversion, with old boilers having an efficiency of 70 - 75 % compared to new A-rated condensing boilers having efficiency of up to 88 – 90 %. Small incremental improvements to boiler efficiency can also be made by tuning the temperature of inflowing and outflowing water. For installation of a new boiler, energy savings of 19 % were calculated for the three occupancy patterns; in absolute terms, there were greater savings for the daytime-present couple as the overall energy consumption was higher in this occupancy pattern. For the comparison of thermal comfort delivery, improved boiler efficiency was subjected to a partial rebound effect such that the energy delivery of the heating system increased by 10 %. In general, this led to an improvement of the delivery of thermal comfort, measured as a heating comfort gap (HCG) reduction of over 30 % in the living room of the working family (WF) and working couple (WC), 8 % in the bedroom of the WC, and 2 % in the bedroom of the WF, however a 25 % increase in HCG was measured in the living-room of the daytime-present couple (DPC). When comparing the modelled results to statistical data on energy savings following boiler upgrade (DECC 2013a), the modelled values of 19 % savings in Chapter 5 (without any rebound) and 14 – 15 % saving in Chapter 6 (with rebound) are above the median value of 12.4 % for a 3 bedroom semi-detached house, but within the upper and lower quartile (27.5 % and -7.7 % respectively). The large range between the upper and lower quartile demonstrates the significant extent to which behaviour might affect the savings potential of a new boiler, and the model used in the present work could be improved by incorporating yet more aspects of behaviour as discussed in section 5.7. Additionally, with greater focus on modelling the temperature of the water at all points around the house, the variations in the efficiency of the boiler could be better included in calculations; this is possible using the modular form of TRNSYS but has been beyond the scope of the present study.

Incorrect sizing of a boiler within the heating system of a house can result in it being unable to deliver and maintain a comfortable indoor temperature; an inefficient boiler can mean

that energy is wasted and not converted to useful heat within the room and therefore delivery of HTC is compromised. The benefit of an efficient boiler to both address fuel poverty and reduce energy wastage has been recognised by policy makers and resulted in financial policies offering subsidies for new boilers and money for scrapping an old boiler. It is recommended that such policies stay in place and ensure that all conventional, low efficiency boilers are replaced as soon as possible. However, additional measures should be addressed at the same time such as information dissemination to ensure that the temperature of the heating system is set at the most appropriate value and that the heating system is balanced to allow all rooms to be heated properly.

### 7.2.1.2 *Passive system*

Improvement to the passive system in this work has focussed on insulation of external walls and roof. The key parameter was identified as thermal loss (U-value), [W/(m<sup>2</sup>K)]. Overall, these measures have been demonstrated to perform very well in both reducing energy consumption and delivering thermal comfort. Energy savings due to insulation were similar for all three occupancy patterns, with a calculated saving of 11 – 12 % for roof insulation, 19 – 20 % for internal wall insulation and 30 – 32 % for a combination of both. When considering the delivery of thermal comfort, insulation performed well, especially in the bedroom of each occupancy pattern where it outperformed all other measures (with the exception of thermostat only heating control). Roof insulation demonstrated higher thermal comfort improvements than internal wall insulation and this can be attributed to the greater level of insulation which was assumed possible in the roof than the wall and therefore greater reduction in heat loss. In comparing the modelled energy savings to statistically measured energy savings for insulation (DECC 2013a), the modelled values are fairly optimistic. For roof insulation, the modelled energy savings (11 – 12 %) are significantly higher than the median value of 3 % and are towards the top of the expected range, between an upper quartile of 18 % and lower quartile of -13 %. For solid wall insulation, the modelled energy savings in the range 19 – 20 % are closer to the median value of 14 % and are within the expected range (between an upper quartile of 31 % and lower quartile of -3 %). A 1 °C comfort taking rebound effect was calculated to cause a 6 – 8 % energy saving reduction for loft insulation and a 4 – 6 % energy saving reduction for solid wall insulation. With the inclusion of this effect, the modelled values are closer to the statistical median savings values. Comparison values are not available for combined roof and wall insulation, but it is likely that 30 – 32 % energy savings will be higher than the typical energy savings measured for such energy efficiency improvements.

The consistent performance of passive system upgrade across all occupancy patterns within the analysis of the present work means that passive system improvements are especially

suitable for homes with frequently changing occupants such as the rental sector or social housing. The main barriers to installation of insulation (as identified in Table 5-12) were financial cost and disruption caused by installation. Of the numerous national policies which have attempted to overcome the financial cost of insulation (as discussed in section 2.4.2), rates of insulation increased up until 2013, falling sharply as free installation (CERT/CESP) was replaced by loans for insulation (Green Deal). Even when given away for free, take up of roof insulation had been lower than expected; in an evaluation of non-adoption of loft insulation, 80 % of people identifying ‘hassle’ related reasons (trouble in clearing loft, loss of storage space, disruption in the home) (Dowson et al. 2012; Gilchrist & Craig 2014; Mallaburn & Eyre 2014; Caird et al. 2008). For low income households, insulation and improvement to the building envelope are shown to be the most effective way of tackling fuel poverty and therefore financial support for the insulation of these homes should continue. However, for more affluent households, a different approach is required as the barrier of disruption is more prevalent than upfront cost. As was discussed in literature by Wilson et al. (2015), insulation tends to fit within larger renovation projects and therefore focus should be made on how energy efficiency recommendations can coincide with these large projects. This could be ensured through regulation on energy efficiency standard improvements with home improvement work, such as the consequential improvement rule which was discussed in section 2.4.2, and by ensuring that the key actors in home improvements (tradespeople, DIY shops, magazines) are promoting insulation when most likely to be adopted.

### *7.2.1.3 Service control*

A range of heating control options have been included in this work, enabling heating to be adjusted by temperature, time and location, as well as simulating the capability of advanced controls to be controlled remotely. In Chapter 5, a base-case scenario of timer control was employed, and energy savings are calculated relative to that level. The improved capability of heating controls has proven to deliver greater savings in occupancy patterns which are more varied; modelled savings were greater in the WC (15 % energy savings) compared to the WF and DPC (11 %). However, the more simple addition of thermostatic radiator valves (TRVs) delivered greater savings in the DPC (9 %) compared to the WF and WC (6 % and 5 % respectively). When considering thermal comfort delivery, thermostat-only control and manual control were included in the analysis. Thermostat-only control delivered the highest level of thermal comfort in all modelled cases (but with a high heating energy demand), whilst manual control performed poorly in all cases due to the lack of warm-up time prior to occupancy. For the other control types, heating controls performed better in the living room than the bedroom. Timer and timer-with-TRV controls had very similar values of HCG in all cases. Advanced zonal heating



control (AZHC) delivered a lower level of thermal comfort than timer and timer-with-TRV control options in all cases. This poor delivery of thermal comfort by AZHC is likely to be due to the shorter heating period leading to a lower temperature being reached and the heating being controlled from the living room thermostat rather than from within the bedroom. In comparing the modelled energy savings to measured energy savings, AZHC showed a good match between modelled energy savings (11 – 15 %) and energy savings measured in a study of zonal heating (14 % energy savings) (Beizaee et al. 2015), however the modelling of energy savings for advanced control options could be improved by including the effect of zonal heating on boiler efficiency.

The results of this study have shown that the savings achievable with heating controls do depend on the household, confirming the findings of other work that it is “not the presence or absence of particular controls that is important, but rather how people choose to interact with the technology that really matters.” (Kelly et al. 2013). The interaction of people with controls could be further exemplified within modelling if more aspects of occupancy behaviour were integrated, as described in section 5.7. This study has shown that more advanced control technologies with greater potential for energy saving can compromise the level of thermal comfort delivery.

The major barriers to the take up of more advanced types of heating control are identified in Table 5-12 as expertise for operation and inconvenience of operation. The wide acceptance of heating controls will depend on their ease of use but it is expected that they will remain most suitable for those who are technology competent unless additional help can be given to enable those without sufficient know-how to use the heating controls to their best ability.

Advanced heating controls have previously been identified as a DECC research priority (DECC 2015; Rubens & Knowles 2013), chosen particularly on its potential to reduce the rebound effect from other energy efficiency retrofit work. The results of this work confirm that advanced zonal heating control alongside other measures can deliver equivalent heating energy savings to other more costly and disruptive measures. It is recommended that in order to maintain thermal comfort throughout the house additional advanced capabilities are included in control design, such as enabling communication from all zones of the house rather than only via the central thermostat in the living room, and learning occupancy patterns in order to instigating the start of a heating period based on internal and external temperatures. Without these capabilities, the energy savings offered by the heating controls are diminished and the play-off between energy savings and HTC delivery will need to be optimised for each household based on their values of comfort, cost and environmental awareness.

#### *7.2.1.4 Service level*

Options for reducing the level of service demanded have been represented in this work as temperature reduction and partial under-heating. The energy saving potential of a 1 °C temperature decrease was calculated to be 9 % and for a 2 °C temperature decrease this rose to 17 – 18 %. In comparison to other modelled values for a 1 °C and 2 °C temperature reduction (9 % and 13 % respectively) (Palmer et al. 2012), the scale of energy savings are in agreement, especially for a 1 °C temperature decrease. Partial under-heating has been investigated in most detail within Chapter 4, in which the potential energy savings varied based on two key parameters of proportion of house under-heated and temperature set-point of under heated areas. Savings also depended on the external temperature and the thermal resistance of the internal and external walls of the house. Partial heating was found to be more effective for a house with poorer thermal insulation of external walls and lower thermal transmission of internal walls which prevent internal heat losses from heated to under-heated spaces. In the modelling of Chapter 5, partial under-heating was limited to the secondary living room and secondary bedrooms (a proportion of 22 % of total area), which were heated to 16 °C (compared to 21 °C in occupied rooms). Partial under-heating was not applied to the working family occupancy pattern as it was deemed that the house would be fully occupied. In the WC and DPC, energy savings were calculated as 18 % and 17 % respectively. These modelled values are considerably higher than comparable modelled values of 4 % (heating turned off in 1/6 of home) (Palmer et al. 2012), and therefore additional measured validation is required to further verify what value of the energy savings is realistic through partial heating. In consideration of thermal comfort delivery with a decreased service level demand, a 1 °C temperature reduction was found not to affect the calculated level of thermal comfort delivery (comparison made with timer heating control). This is because the modelled temperature profile decreased to the same extent as the decrease in demand level.

Not all households can reduce their demanded level of service as households in fuel poverty typically have low indoor temperatures and do not heat the whole house already; an EEM of service level reduction is therefore not directed at these households. Instead, a reduction in service level should be promoted predominantly to those with an above average level of service demand (internal temperature above 21 °C and/or large house compared to number of occupants). The acceptance of such an EEM will depend on the values of the household, and the importance of cost or carbon savings as compared to comfort. By showing the energy saving potential of turning the thermostat down or not heating an un-occupied room alongside technology measures, people who feel they want to do ‘their bit’ but don’t know what to do may choose service level reduction options.

There is some disagreement between disciplines as to whether a reduction of service level should be expected at the individual level. Energy saving rhetoric has often focussed around individuals taking small actions which will ‘all add up’. The effectiveness of such an approach is disputed by social practice theorists who believe that the choice of heating practices are dictated by wider social culture and that as internal temperature demand and heated space within a house have increased over time as a cultural norm, a reduction would happen in a similar society wide way. Literature around sufficiency has also supported the notion that reduction in service level demand should be led by government policies and individuals as politically engaged citizens rather than individual consumers choosing to consume less (Shove 2003a).

### **7.2.2 Data availability as a limitation for technology assessment**

A key decision within this project was to not undertake primary data collection and instead rely on data gathered from literature. This decision was made due to the wide range of data required, such as typical values of key parameters for EEM, whole house energy consumption at different levels of each EEM for the purpose of validation, detailed information about heating behaviours such as how people use heating controls and indoor temperature settings, and evidence of changes in energy practices and energy consumption values following energy efficiency retrofit. It was not considered possible within the scope of the thesis to undertake sufficient primary collection for all empirical data requirements, and therefore this work has been based on figures available within academic and industrial literature, with assumptions being explained where relevant. Additional data in the following areas would enable improvements to this work:

- EEMs have been modelled by using data on typical performance taken from industry literature and empirical studies. One example of where these sources differed was in the U-value of a solid wall, as explored in section 5.4.2.2 where the standard values are different to values measured in empirical studies. By using these empirical values, the calculated energy savings are lower than if the standard assumptions had been used, but the calculated savings are still higher than the statistical average. Additional studies on the heat loss through walls are on-going (including how U-value varies for a wall due to external factors) and the results of these studies will help to improve model calculations further.
- Validation has been made through comparison of calculated energy savings to statistical data and by comparison with measured data for both the whole house and for individual EEMs. In comparing whole house energy consumption, the modelled values were higher than statistically measured gas consumption values

and this has been attributed to the omission of heat gains and the significant effect of assumptions on the conversion between heating energy demand and total gas consumption. Better validation would be gained if the modelled scenarios could be matched to a physical house, either as a test house or one which is being lived in (with sufficient knowledge of building and occupant parameters). With this additional validation data, improvements could be made to model parameters used.

- Data for the calculation of embodied energy in technologies was taken from literature. For insulation, accurate data is available for embodied energy and CO<sub>2</sub> for a wide range of insulation types and this makes it possible to include the upstream energy of insulation in a reliable way. However, data was not available for a new condensing boiler and therefore values for embodied energy and embodied carbon had to be estimated based on material composition and other boiler types. Conversely, only one life cycle assessment (LCA) of heating technologies was available and this gave results in terms of CO<sub>2</sub> rather than energy. The estimate values for embodied energy and embodied carbon in technologies showed that their contribution was only a small proportion of energy consumption and therefore it was decided that further LCA work was not a priority in this project. Further work on upstream energy should also include energy for transport, delivery and maintenance of technologies in order to represent the full energy chain.

### **7.2.3 Additional technologies for a wider application**

The majority of this thesis has focussed on the service of thermal comfort, and in particular heating to provide a comfortable temperature. Four approaches to lower carbon energy service delivery have been compared, and in order to further expand the analysis, more types of technologies could be included. For each approach to service delivery already considered, additional options could be investigated such as a furnace as an alternative conversion device (which inputs heat as warm air rather than circulating as hot water), more efficient windows or use of curtains as passive system improvements, or heating controls which can adjust the start of a heating period based on a forecast of the time taken to reach occupied temperature within a room. Also, further stages on the service delivery chain could be investigated, such as renewable generation on site (solar panels or heat pumps) or the effect of higher levels of renewable electricity generation in the grid delivered through a 'green tariff'. These options would broaden the scope for identifying the most promising areas of energy savings whilst still delivering thermal comfort and welfare satisfaction.

The four approaches to energy efficient service delivery could be applied to other services, in which case the methodology would include the identification and modelled comparison of technology aspects of the service delivery corresponding to conversion device, passive system, control and level. To go further within thermal comfort, cooling could be investigated which will be most relevant with a warm climate. Air conditioning is already a major electricity end-use in much of the world, and its use is predicted to increase significantly over the coming decades (Lundgren & Kjellstrom 2013; Henley 2015). In some ways, cooling would be similar to heating in terms of energy efficiency of service delivery, particularly for control and service level (although a temperature increase rather than decrease would be considered). For a conversion device, the 'coolth' generation technologies listed in Table 2-6 are possible examples; air conditioner units, electric chillers and heat pumps. These technologies convert electrical energy or heat energy to mechanical energy or to potential energy within a change in pressure or phase. Air movement technologies can also be considered such as a fan which converts electrical energy into kinetic energy which creates enhanced air movement. For the passive system, heat removal technologies can be considered such as building design for passive cooling and natural ventilation; in many hot countries, passive cooling has been fundamental to building design for centuries and therefore good-practice examples can be used elsewhere. Insulation can also be considered for cooling as heat transfer into the building is reduced.

When broadening consideration from domestic buildings to commercial buildings, technologies typically change; conversion devices are more commonly furnaces with ducting to transport warm air around buildings, and control is typically undertaken by staff members using building management systems. Consideration of service level in commercial buildings will be varied as the differences in perception for different people are more prevalent. It is therefore expected that differences in results would be significant between domestic and commercial buildings, and different again when considering other building usage such as hospitals and schools.

Beyond thermal comfort, the same approach of technology and energy efficiency measure breakdown could be applied to other services, and examples are given for sustenance and hygiene in Table 7-1. Both services can be broken down further; hygiene comprises personal washing, laundry of clothing or cleaning of house, whilst sustenance, can be broken down into food storage and food preparation. Each sub-service can be considered separately but with some overlap.

*Table 7-1 Application of service technology breakdown to energy services of sustenance and hygiene*

		<b>Service : Sustenance</b>	
		<b>Preparation</b>	<b>Storage</b>
<b>EEMS</b>	<b>Conversion Device</b>	Transfer of heat to food: Oven, hob/stove top, microwave	Conversion of fuel to 'coolth': refrigeration system
	<b>Passive System</b>	Retention of heat for cooking: Oven insulation, thickness of pans	Creation of cold or dry place: insulation of refrigerator or freezer, thick walls of pantry or cold store
	<b>Service Control</b>	Cooking temperature, cooking time	Temperature of refrigerator, lifetime of food
	<b>Service Level</b>	Portion size, type of meal, diet	Amount of food stored, proximity to shops, requirement of freezer
		<b>Service : Hygiene</b>	
		<b>Personal</b>	<b>Clothing</b>
<b>EEMS</b>	<b>Conversion Device</b>	Conversion of fuel to hot water: Boiler, solar hot water	Conversion of fuel to hot water: boiler, washing machine
	<b>Passive System</b>	Delivery of water to person: Bath, shower, wash-basin	Washing machine volume, washing machine drum orientation, washing basin
	<b>Service Control</b>	Power of shower	Temperature of wash, use of detergent, spin speed
	<b>Service Level</b>	Frequency of washing events, type of washing events, length of shower, depth of bath	Frequency of washing events, size of washing machine

### 7.3. Energy service theory

Analysis of energy service theory in the literature review (section 2.2) highlighted three themes by which energy service concept can be used to reframe the current system of energy use. The work undertaken within Chapters 4, 5 and 6 is evaluated and the contribution to each theme is expressed in section 7.3.1. This is followed by a consideration of the limitations of the energy service application approach used in this thesis. Finally, the focus is broadened to discuss how the energy service approach could be applied to other services beyond heating thermal comfort.

### 7.3.1 Contribution from this thesis to energy service theory

#### 7.3.1.1 *Energy service energy chain*

The full energy chain from primary energy to welfare was presented in Figure 2-1, and much of the focus of this thesis has been around the energy chain step of final energy to energy service. The four approaches to technical intervention are based around the approaches to service delivery. These were compared for three hypothetical definitions of service demand.

Upstream, the energy supply and distribution step of the chain was a focus of Chapter 4, including calculation of embodied energy and conversion of final energy to resulting CO<sub>2</sub> emissions. Embodied energy was found to account for only a small fraction (less than 1 %) of the total energy demand for service delivery, and for all technologies, the energy required in manufacture is small compared to the modelled energy savings calculated for their use. Data availability for embodied energy is considered as a limitation as described in section 7.2.1 above, and with better data availability, embodied energy could be brought into building modelling, potentially through linking up to technology and materials databases. It was decided not to include the contribution from embodied energy in subsequent chapters due to the small contribution it made to the total energy demand. The translation from energy to CO<sub>2</sub> emissions undertaken in Chapter 4 showed the difference between improved efficiency condensing gas boiler and electric resistance heater as two types of conversion device. Although the electric resistance heater had lower final energy consumption, the calculated value of CO<sub>2</sub> emissions was far higher (in reality, the cost is far higher also, however energy cost was not the focus of this work). This led to the electric resistance heater being discounted from further analysis and as all energy service delivery was thus gas fuelled, comparisons were made in terms of energy only.

For inclusion of the energy service to welfare step, consideration was made for the suitability of technologies and measures for different types of people. Categorisation according to motivation for energy efficiency improvement was informed by the modelling results in this work. The results of energy saving calculations in Chapter 5 were able to inform the suitability for those motivated by financial savings (cost) or environmental concerns (climate). Modelling of the delivery of HTC energy service within Chapter 6 was able to inform on the suitability for those motivated by the warmth of their house (comfort). The culmination of this analysis is presented in Table 7-2 in which EEMs are categorised according to the technical skill or knowhow required and the motivation or priority in heating behaviour. Categorisation according to technical confidence is achieved by considering barriers to technology adoption which relate to skill and knowhow. The usability of heating controls has been previously studied (Combe et al. 2011) and provides

insight that some users lack the technical skill required to operate controls to their full capability. Installation of large technical measures requires the co-ordination of professional tradespeople and installers which requires a different type of householder ability.

*Table 7-2 Suitability of EEMs to occupancy factors of technical confidence and priority in energy efficiency improvement. CD: Conversion device; PS: Passive system; SC: Service control; SL: Service level.*

		<b>Technical Confidence</b>		
		<b>Limited technical skill / knowhow</b>	<b>Skill to use technologies with confidence</b>	<b>Know-how to arrange professionals to carry out work</b>
<b>Motivation for energy efficiency improvement</b>	<b>Comfort</b>	SC: TRVs	SC: TRVs	CD: Boiler upgrade PS: Solid wall Insulation PS: Roof Insulation SC: TRVs
	<b>Cost</b>	SC: TRVs SL: Reducing internal temperature SL: Partial under-heating of house	SC: TRVs SC: AZHC SL: Reducing internal temperature SL: Partial under-heating of house	CD: Boiler upgrade PS: Roof Insulation SC: TRVs SL: Reducing internal temperature SL: Partial under-heating of house
	<b>Climate</b>	SC: TRVs SL: Reducing internal temperature SL: Partial under-heating of house	SC: TRVs SC: AZHC SL: Reducing internal temperature SL: Partial under-heating of house	CD: Boiler upgrade PS: Solid wall Insulation PS: Roof Insulation SC: TRVs SL: Reducing internal temperature SL: Partial under-heating of house

If technologies are recommended and installed inappropriately, the energy savings will be lower than expected and delivery of heating thermal comfort may be compromised. However, the boundaries of each categorisation are not static and some well-designed intervention could enable technologies to overcome barriers. Barriers to technical skill required for heating controls may be reduced by better instructions (printed or delivered verbally) and more intuitive design. For some users, trusted individuals such as family members and advice groups may be able to help overcome difficulty of understanding, or aversion to, new technologies. Barriers posed by access to professionals can be overcome by making available lists of recommended tradespeople by reputable bodies, and advice groups helping to negotiate complicated procedures for arranging work. Suitability due to cost can be affected by governmental policies and grants and also factors of scale, with technologies reducing in price as their market penetration increases. Suitability due to



comfort can be ensured for heating controls by continual development of how the controls work throughout the house and it is preferable if all controllers can communicate with the central boiler.

### *7.3.1.2 Additional insight gained for development of domestic energy service companies*

The focus of this thesis on the energy service concept enables greater insight to be gained on the performance based energy economy and the application to the development of domestic energy service companies. By comparing EEMs for delivery of energy service as well as potential energy savings, this work expands the application to energy efficiency retrofit to move into the realms of the performance based energy economy.

With reference to a domestic energy service company (DESCo) business model, as introduced in section 2.2.2, a key requirement is to predict how EEMs would perform in a specific house. A DESCo would want to ensure that energy efficiency interventions will maintain the promised level of service or to be able to quantify the service delivered. In order to negotiate a certain level of service, the heating comfort gap (HCG) metric could be used within as a service description; the DESCo could be contracted to deliver a specified internal temperature for certain times of the day within a contracted upper limit on HCG. If the service delivery can be empirically measured in the house before and after an energy efficiency intervention, comparisons in service delivery could be made based on averaged temperature profile and HCG in order to assess the performance of the intervention. The inclusion of service level reduction as an energy efficiency measure within the present study highlights how such an intervention could be accounted for within a DESCo service agreement such that a lower service level delivery could be offered at a reduced cost.

Accurate modelling of the performance of EEMs is important for the DESCo business model in order to predict the delivery of the agreed service and the energy savings. Such calculations are necessary in order to arrange a contract with a customer and to forecast company profits based on energy cost savings. The service delivery and cost savings should be calculated as accurately as possible, but where it is not feasible to model each individual house, more accurate estimates could be based upon an understanding of the effects of house type, occupancy pattern and heating behaviours.

### *7.3.1.3 Consideration of sufficiency*

The third theme identified for reference to energy services in the literature was the consideration of energy sufficiency alongside energy efficiency. Some aspects of the energy sufficiency concept have been used or addressed within this thesis, and others justify further consideration.

As a strategy to reduce energy consumption, the present study has incorporated Brischke et al.'s (2015) three interventions which were substitution, reduction and adjustment, as discussed in section 2.2.3. Substitution has been the focus of comparing different technologies and measures to deliver the same service of HTC. Inclusion of reduction has been represented by considering how a change in service level as comparable EEMs (reduced temperature and partial heating). Adjustment has been considered through the inclusion of heating control as EEMs which aim to match the service delivery to the spatial and temporal service demand as well as possible.

Boundaries of what level of service is sufficient could be brought into modelling work as a minimum or maximum level of service, particularly using the modelled output of HTC delivery as developed in Chapter 6. A minimum energy service level could address the provision of a safe level of service and is most applicable to households in fuel poverty. The model could identify EEMs which generate a low temperature profile or high value of HCG as falling short of a safe indoor temperature during occupied periods. A maximum level of energy service could apply if energy savings are lower than they 'should' be (particularly for larger houses). With the introduction of limits and personal carbon allowance, the model could return EEMs which comply with required energy demand levels and confirm the level of service that this would correspond to. If an internal temperature is inputted which exceeds the maximum, the model could automatically calculate the possible energy savings for a lower internal temperature. A descriptive norm approach (an example of a psychology intervention as discussed in section 2.3.2) could be incorporated, providing messages such as 'you could save  $x$  % if you set your thermostat to a value of 21 °C like your neighbours on this street'.

In order to address the discrepancy between an inability to attain an appropriate level of service and rebound effect of increasing demand of service level, there is potential for extra information to be provided in a building model with reference to energy 'needs' and energy 'wants' (as discussed in section 2.2.3). Building models could calculate and display the energy consumption for a healthy level of service (need) separately from the energy used beyond requirement, for ever increasing internal temperature and potentially wasteful behaviours (want). This could be applied to variables of internal temperature, time of heating and amount of house which is heated. To develop the potential for differentiated service need and want however, a safe and healthy level of need must be identified. This could be done by scientific methods (safe temperatures which are not harmful to health), or by quantitative survey of broad public opinions, but would require empirical work to ensure results are reasonable and fair. Considering energy use as split between satisfying need and delivering increasing levels of want, the difference between sufficiency and efficiency could be highlighted in model results. Disparity in levels of delivered service

between different households is a key barrier to financial policies being used to encourage energy efficiency; if some households cannot afford to maintain their homes at a safely warm level, financial instruments such as an energy tax should not be applied to energy at all.

Satisfaction of welfare cannot be modelled as it is subjective and can depend on many varied factors and requirements which change between people as well as at different times and situations for any single person. Many studies have shown that above a certain level of energy service provision welfare is independent of service level and therefore there are no easy criteria for welfare being satisfied. The minimum level of service provision (such as safe internal temperatures) below which it can be assumed that basic needs are not being fulfilled and welfare not delivered should be independent of lifestyle. However, expectations of basic requirements have increased in recent decades such as proportion of house which is heated, or access to certain appliances, and therefore the definition of 'human need' is in flux.

#### **7.3.2 Limitations for energy service application**

##### ***7.3.2.1 Measurement of thermal comfort***

A major assumption within this thesis is that thermal comfort analysis has been limited to internal temperature, without inclusion of other factors, such as humidity, air movement, clothing level and activity level. Clothing level and activity level would dictate a more variable comfort temperature profile throughout the day which could be predicted as an updated input schedule to the model, or alternatively could be based on probability and a schedule could be generated for each simulation run to introduce variability. Humidity and air movement could be treated as additional limits to be satisfied for the delivery of thermal comfort, or could affect the value of the comfort temperature used as an indicator of thermal comfort.

##### ***7.3.2.2 Heating practices***

In order to strengthen the occupancy side of modelling, additional data is required on how people use their house. The discrepancies found in some studies between what people say they do and what they are observed to do (Love 2014; Gauthier & Shipworth 2014) demonstrates the benefit of data collection comprising both qualitative and quantitative aspects, each of which can give added value to the information gained through household behavioural studies.

Although data is available for indoor temperatures, especially from the HES CaRB (Shipworth et al. 2010) and 4M projects (Lomas et al. 2010), additional insight would be

valuable on patterns of internal temperature throughout the house. Typically, studies have focussed on temperatures in living room and bedrooms which does give a good indication of variation within the home, but further data on typical temperatures in other zones of the house could improve the modelling of these spaces.

A number of studies have focussed on variation in heating practices, including following energy efficiency retrofit, but more would be useful. Evidence of how heating practices change, accompanied by measured data on changes in energy consumption and internal environment would enable further validation of the building model, greater inclusion of heating practices in building modelling and rebound effects to be better addressed.

### **7.3.3 Application to other energy services**

The focus of this thesis has mainly been on the energy service of heating thermal comfort, but the analysis application could be applied more widely to other services. Technologies for delivering other services have been suggested in section 7.2.3 above, and these were based on the distinctions of conversion device, passive system, service control and service level as used within the present study. Further application of this approach to energy service consideration would be to continue the focus upon all stages of the energy chain. Upstream, the supply system from primary to final energy can be included as in the present work with calculation of embodied energy, as well as primary energy demand and resulting CO<sub>2</sub> emissions. Inclusion of the energy service – lifestyle – welfare link is enabled by identifying which aspects of practices, either within the household or beyond, would affect the suitability of technology adoption. When defining a service unit as a basis of comparison, consideration of progressive efficiency is recommended (as endorsed by Harris et al. (2008)) so that energy conservation, rather than energy efficiency, is ensured. The definition of service can be developed using the service dimensions framework presented by Jonsson (2011; 2005), as done for heating thermal comfort in Table 3-1. A final consideration for the transfer of the present analysis to other services is which type of modelling is most suitable. For some domestic services, a similar model as created in TRNSYS could be used, for example for services of cooling thermal comfort, illumination and hygiene. However, for other services, systems dynamics models may be more suitable which can include aspects of demand and technology interaction more fully.

## 7.4. Building modelling

The modelling work undertaken in Chapters 4, 5 and 6 have shown developments made in order to better model the energy service being delivered by energy efficiency technologies and measures alongside energy savings attainable. These developments have been consolidated and are discussed in section 7.4.1. Limitations of the building modelling approach are then considered. This section concludes with an examination of broader applications for the building model developed within this thesis, in terms of potential for application to other scenarios and the prospect of developing it into a building modelling tool with a focus on energy service.

### 7.4.1 Developments made in building modelling approach

Within this thesis, a range of heat balance modelling approaches have been used, and this process of development can inform the necessary requirements of building models for use in comparing energy efficiency technologies and energy services. In Chapter 4, key parameters for technologies and measures were identified and a simple quasi-steady-state model was used to gain understanding of how the key parameters affected energy savings. In Chapter 5, EEMs were translated into model parameters within TRNSYS and a Matlab script was used to simplify the process of running multiple simulations for EEM appraisal. The comparison of results with validation figures taken from literature showed that overall, the model overestimated annual energy demand as compared to UK statistical data. This over-estimation is attributed to the fact that some aspects of household energy use were omitted due to simplification (such as heat gains and use of secondary heating), and can also be due to the omission of vacant periods within the property (such as holidays and weekends away). In comparison of energy savings calculated, the savings for passive system and conversion device measures were within the expected range of upper and lower quartile, but higher than the median. This finding suggests that rebound effects are to be expected, or that the quality of EEM installation is lower than specified. The scale of rebound for a 1 °C comfort taking was calculated at 4 – 8 %. The sensitivity analysis showed that energy demand calculations were most sensitive to the choice of internal demand temperature and boiler efficiency. In Chapter 6, the requirements of the building model were increased, and it was upon comparison of modelled temperature profile to measured temperature profile (Beizae et al. 2015) that it was identified that an enhanced model was required. This enhanced model used TRNSYS radiator units and thermostat control modules for the better simulation of a wet radiator system. In temperature profile comparison with measured data, the enhanced model showed better agreement, but work is still required to improve modelling further.

Fourteen heating practices were identified in the literature review and presented in Table 2-3, and of these heating practices, six were included in the modelling of this thesis. Length of heating period was represented by three occupancy patterns in Chapters 5 and 6, and was shown to cause significant variations in energy demand and in the effectiveness of different EEMs (as discussed in section 7.2.1. Temperature set-point was modelled as a service definition variation in Chapter 4 (displayed in Figure 4-5(b)) and although energy demand was different between each temperature set-point preference, the relative performance of each EEM was not changed. Temperature set-point was also considered in section 5.6.3 as a rebound effect and although an increase in temperature following energy efficiency intervention was found to reduce energy savings, the relative performance between EEMs was again unchanged (although rebound effects might be more prevalent for some technologies than others). The use of temperature controls, proportion of house heated, personal heating (reduction in set-point temperature) and varying heating between rooms were considered as EEMs in chapters 4, 5 and 6, and the adoptability of such practices will determine whether they are suitable for specific households. The process for inclusion of additional heating practices in modelling (use of secondary heating, window opening, internal door opening and further representation of use of heating controls) were described in section 5.7 and inclusion of these within modelling could allow further investigation into how the practices affect the variation between EEMs, and whether energy saving levels are compromised by such behaviours.

#### **7.4.2 Limitations of modelling approach**

Deviation is expected between modelled results and measured comparison as not all aspects of the home have been included in detail in the model developed for this work. Internal gains are a modelling aspect which has been neglected, and this is because internal gains vary so much between households. The ground floor has been treated very simply in the modelling, with the temperature held at a constant value of the annual average air temperature (10 °C) and U-value of 0.86 W/(m<sup>2</sup>K). Air flow as infiltration has been included in the model as an air-change of 0.5 – 1.0 of the volume of each room per hour depending on the state of the building envelope. However, air flow between rooms has been neglected.

#### **7.4.3 Broader application for building modelling approach**

##### ***7.4.3.1 Potential for scaling up model for broader application***

Most of this thesis has focused on one individual house type and variation in households has been represented by three cases based on different occupancy pattern. For a broader application, greater variation within occupancy and geography could be incorporated.

There is also further consideration required if the modelling approach were to be scaled up to macro building model application and these are all discussed below.

In the present work, occupancy pattern has been included in analysis as three common but distinct examples; WF, WC and DPC. Household occupancy does, however, vary far more greatly than has been modelled in this work, requiring both more alternative types of occupancy patterns and greater variation within each individual's occupancy pattern. The latter has been attempted in a range of modelling studies by using statistical occupancy pattern generation methodologies (Richardson et al. 2010; Paauw et al. 2009; Aerts et al. 2014). This approach based on the probability of occupancy at times during the day or behaviours such as window opening can help to better represent the variation in occupancy as the effects of energy efficiency work are scaled up nationally.

In order to scale up the results of this analysis to make recommendations for energy efficiency work nationally, the effects of geographical variation must be taken into account. The two more relevant effects of geographical situation are the local climate and the typical housing stock in the region. For the modelling in this thesis, TRNSYS has used a typical meteorological year for London/UK, and this data has been compared to measured data sets from regions in the south of England in the year 2012 in section 5.6.1, showing similar numbers of heating degree days (HDDs). It is expected that regions further north which have lower external temperatures during the heating season and longer heating seasons will be able to gain greater energy savings in real terms, but the comparison of percentage savings between EEMs is expected to be similar.

With regards to the differences in housing types, the present study has focussed on a hard-to-treat solid wall semi-detached house. A simple comparison in Chapter 4 of a detached house (147 m<sup>2</sup> floor area), a semi-detached house (93 m<sup>2</sup> floor area), and a terraced house (80 m<sup>2</sup> floor area) showed the same pattern of heating energy demand savings for five EEMs (conversion device, passive system and control technologies) in each house type. However, to understand whether house type affects energy savings from different EEMs, further investigation is required in the more sophisticated TRNSYS model. Socio-economic and cultural factors are also expected to vary with geography, however there are likely to be large variations in household values and levels of technological competencies within any geographical area too, and therefore these are better considered separately within the household archetypes as discussed above.

A large application of building energy modelling is for planning on a macro scale across cities, regions or countries. The modelling of energy services would therefore need to be scaled up to this level and understanding of factors which dictate adoption and suitability is most applicable when scaling up results to make broad recommendations on the types of

EEMs which should be priorities in national level energy efficiency programmes. In order to do so, individual households would need to be categorised such that similarities between them could be used to inform most appropriate measures, geographical variation across the UK would need to be addressed, and considerations are required for how the building model would be adapted.

When scaling up building modelling to assess the effects of energy efficiency measures on a national scale, the model must necessarily be less complicated and therefore the benefits of the current modelling work could be lost. Models for the prediction of energy savings due to energy efficiency measures on a national scale have already been built, such as the Cambridge Building Model (Hughes 2011), and through this model, comparisons of the effectiveness of different approaches to delivering thermal comfort could be made, such as comparing conversion device, passive system, service control and service level. However, the ability to model the temperature profile due to these measures is more difficult at a larger scale and it is therefore recommended that representative cases are still used to predict how well each EEM type can contribute to the delivery of thermal comfort in different types of houses. These results can then be taken as indicators to be used alongside household archetype recommendations for which EEMs may be more or less suitable for different types of household. Greater representation of the variability of results as displayed in Figure 5-10 would enable a better understanding of how household occupancy and practices can affect expected savings on a macro scale.

#### *7.4.3.2 Development of building modelling tool with focus on energy service*

The ultimate application of this work would be to develop a commercial tool for energy efficiency measures to be recommended based on their ability to deliver lower carbon energy services. Although such a tool has not been developed through this work, key aspects have been identified for what this tool would look like. For the model inputs, the effect of building occupancy has been demonstrated and the methods for including other aspects of heating behaviour were discussed in section 5.7. The sensitivity analysis of section 5.6.2 has shown that the factors of households, house types and energy behaviours with the biggest impact on energy use are temperature set-point and boiler efficiency and therefore efforts should be made to ensure the data for these are as accurate as possible. Finally, there should be an option for indicating the household motivation and technical competency so that the suitability of EEMs can be taken into account. For the model outputs, the work of this thesis has focussed on two model outputs deemed important for the delivery of low carbon energy service; energy saving (which translates as CO<sub>2</sub> emission reduction), and the delivery of the service, which in this case was heating thermal comfort.



If displaying only one type of result, Figure 5-10 demonstrates how variation in household occupant practices could be displayed graphically. Figure 6-14, Figure 6-15 and Figure 6-16 show both energy savings and heating comfort gap (as an indicator of service delivery) on the same plot, and the addition of zones of suitability in Figure 6-17 enhance the results display by indicating which EEMs would and would not be suitable for a certain household.



# Chapter 8 Conclusion

Having reached this final conclusion chapter, consideration returns to the research questions as defined in the introduction. Within the following section (section 8.1), each research question is addressed in turn, and answered based on the new insight gained from the work of this thesis. In section 8.2, policy recommendations are outlined, and in section 8.3, three areas of further work are identified and introduced, showing the potential avenues for the present analysis to be extended into new areas. The chapter then concludes the thesis in section 8.4 with the author's final remarks.

## 8.1. Fulfilment of research questions

The research questions for this thesis were based around the analytic framework illustrated in Figure 3-2. Three areas of theory and practical application were identified which have potential as approaches for reducing domestic energy consumption; these areas were the energy services concept, domestic energy efficiency technologies and measures, and the capabilities of building modelling. Within the analytic framework, the links between these approaches were identified as the areas for analysis and this led to the determination of the following research questions:

- What contribution can energy efficiency technologies make in delivering low carbon energy service?
- How can the delivery of energy service be included in building energy modelling?
- To what extent can building modelling be used as a tool to recommend improvements to existing housing stock?

The work within this thesis has enabled conclusions to be made towards the overall research aim, which was to demonstrate the value of an energy services perspective for the retrofit challenge. These questions will now be considered in light of the work completed within this thesis.

### **8.1.1 Role of technologies in energy service delivery**

The role of technologies in delivering energy service of heating thermal comfort has been considered at each stage of the energy chain, from primary energy to the delivery of welfare. Although technologies have been considered at each stage in previous studies, such an analysis of technologies through the whole energy chain is novel.

The majority of the modelling work within this thesis has been upon the energy chain stage from final energy to energy services. Improvement in energy service efficiency has been considered for four approaches. The first two approaches of conversion device and passive system were introduced by Cullen and Allwood (2010a) and such a distinction has been used in other studies since (Pérez-Lombard et al. 2011; Knoeri et al. 2015). The inclusion of service control and service level alongside conversion device and passive system has been a novel addition to such an analysis.

Comparison of energy efficiency technologies and measures for retrofit based on energy saving have been undertaken in a wealth of previous studies, but the extension to comparing technologies and measures in terms of their service delivery is novel. Such an analysis provides the opportunity for co-benefits of energy efficiency retrofit to be considered.

The results of the modelling work in the present study have shown that passive system improvements perform best, both enhancing the energy service efficiency and the level of delivered service. Full insulation was found in Chapter 4 and Chapter 5 to be the most effective energy efficiency measure in delivering energy savings across all occupancy patterns. Full insulation also showed highest levels of heating thermal comfort delivery across all occupancy patterns in all metrics, with the exception of thermostat control. Insulation performed particularly well in bedrooms compared to other energy efficiency options; heating controls (except thermostat only) performed badly in the bedroom and this can be attributed to the fact that the control is related to the living room thermostat. For energy savings, heating controls for timing of heating were found to be most suitable to the working couple which had a varying occupancy pattern throughout the week. Heating controls for spatial distribution of heating delivered the greatest energy savings for the daytime-present couple occupancy pattern which had the longest time spent in the house. Combinations of heating control and service level measures showed comparable energy

savings to passive system improvements for the working couple and daytime-present couple occupancy patterns, enabling significant reduction in energy demand despite potential barriers for the installation of insulation. Energy efficiency heating control options were found to deliver a lower level of heating thermal comfort than passive system measures, and performed particularly badly in the bedroom compared to the living room. This is likely due to the type of advanced heating control modelled and it is therefore recommended that advanced zonal heating controls should have communication to the boiler from every room in the house.

The analysis of energy efficiency technologies upstream within the supply stage of the energy chain has been included through calculations of embodied energy within technologies and the resulting CO<sub>2</sub> comparison of different retrofit approaches. Embodied energy of technologies was calculated in Chapter 4, but in comparison with final energy per unit defined service, it was found to represent only a small fraction (less than 1 %) of the total energy input. For all considered technologies, the energy savings due to their installation was found to far outweigh the indirect energy input to make the technologies and embodied energy was therefore not included in the modelling of subsequent chapters. The CO<sub>2</sub> emissions resulting from the delivery of heating thermal comfort were also calculated in the analysis of Chapter 4 in which conversion devices of improved efficiency condensing boiler and electric resistance heaters were compared. Although the heating demand was reduced with the electric resistance heaters, the CO<sub>2</sub> emissions were greatly increased due to respective values of CO<sub>2</sub> per kWh of energy for the two fuels. Electric resistance heaters were therefore discounted from further analysis and since all energy service delivery scenarios were gas fuelled, comparison was made for energy only.

Energy efficiency technologies and measures analysis has been extended beyond energy services to lifestyle and welfare through the consideration of suitability of technologies for different types of householders. Persona archetypes found in literature have been consolidated into two aspects of 'motivation for energy efficiency improvement', with divisions of 'comfort', 'cost' and 'climate', and 'technical competency', with factors of 'skill for using technologies', 'know-how for arranging professional installations' (overlap of these two is permitted), and 'lack of technical competency'. Using these two dimensions, a matrix has been created in Table 7-2 in which technologies are categorised by suitability to different household archetypes. By including consideration of 'motivation/meaning' and 'skill/know-how' dimensions within energy efficiency retrofit recommendation, these commonly identified elements of social practice theory are represented within the comparison, whereas usually energy efficiency analyses focus only on the 'material' and 'rules' (either regulatory or social pressure) elements of social practice theory. Without consideration of suitability of energy efficiency technologies and measures, it is likely that

realised energy savings will be compromised and the delivery of heating thermal comfort will be reduced or will be supplemented in an alternative way with a potentially higher CO<sub>2</sub> impact.

When extending beyond heating thermal comfort to other energy services, it is recommended that a similar approach be undertaken. Energy efficiency technologies and measures for comparison can be identified for conversion device, passive system, service control and service level; for each technology type, the energy or CO<sub>2</sub> input to deliver the defined service can be calculated and compared. Comparison should include the indirect energy input such as embodied energy within the technologies, and should be based on primary energy input rather than solely final energy. Suitability of different technologies and measures should be considered based on motivation for energy efficiency improvements, and the consideration of skill/know-how may extend to perception of inconvenience as different service delivery approaches are compared.

### **8.1.2 Representation of energy services through building modelling**

The concept of energy services has been applied to building modelling, and such an application has been attempted only a few times before.

The definition of a unit of service was developed in Chapter 4, where an explicit occupancy situation was identified as an appropriate representation for heating thermal comfort. This decision is at odds with a common definition of service being a heated unit floor area, as such a distinction can create perverse options to improve energy service efficiency whilst not reducing overall energy consumption. The service unit has been defined as an occupied home for a specified period (such as 24 hours, a month or a year) and subsequently three hypothetical occupancy scenarios were created within chapter 5 and 6 to compare energy efficiency technologies and measures for different service definitions.

In the modelling of energy service within Chapter 5, the delivered service was assumed to be equal in each energy efficiency measure. The energy efficiency technologies and measures were compared singly and in some combinations using a heat balance model created in TRNSYS. In Chapter 6, this model was further developed to enable modelling of the delivery of heating thermal comfort (represented as internal temperature in occupied rooms). The TRNSYS model required modification as the typical heat balance model has been shown to exaggerate heat-up and cool-down period, and therefore the generated temperature profile was not representative of a real internal temperature of a house. The model was developed to better simulate the thermal behaviour of the house and this allowed for four metrics of heating thermal comfort service delivery to be compared. The

temperature profile was found to give a useful visual comparison of service delivery, and by averaging over each time step, an extended simulation period can be displayed. The 'Heating Comfort Gap' metric was developed based on the concept of degree day calculation and allowed the level of temperature shortfall (time and temperature below demanded comfort temperature) to be calculated as a single metric. This single metric of service delivery can be displayed alongside the calculated energy demand, allowing the co-benefits of energy efficiency technologies and measures to be compared.

### **8.1.3 Use of building modelling for recommendation of energy efficiency technologies and measures**

For the comparison of energy efficiency technologies and measures, technologies were represented within the TRNSYS building model. Improved boiler efficiency and insulation are more common technologies to model. The inclusion of improved boiler efficiency is achieved by changing the efficiency value in a unit representing the boiler within the model. Insulation is modelled as layers in the building envelope which can be defined by thermal conductivity and thickness. Heating control and partial heating are not so common, and a innovative approach for modelling was used in which temperature set-point profiles were created to represent each scenario. The comparison between different energy efficiency technologies and measures has been enabled by controlling TRNSYS through a Matlab script created by the author, in which text files are edited and appended together to create input files to the model simulation, as explained in Appendix B and Appendix D.

Building modelling has been a useful tool for the present study and has shown potential for making recommendations of energy efficiency technologies and measures for the delivery of heating thermal comfort with lower energy input and resulting CO<sub>2</sub> emissions. However, the model used in the present study produced results which had some variation from validation data. Overall, the energy demand figures were higher than comparable statistical values for a similar home in a similar UK climate. This discrepancy has been attributed to modelling factors which were omitted from the analysis for the purpose of simplification such as heat gains, which if included, would reduce the overall energy demand figures. The calculated energy savings for insulation measures and boiler installation were within the expected range of statistical data, but were significantly higher than the median values and therefore greater validation work is required before the models could be used to give recommendations in real world examples.

Even with a perfectly calibrated model, however, precaution must be taken before expecting a model to replicate a real-world situation. Humans, and therefore householders, are not rational and their behaviours cannot be predicted to an accurate degree. Significant

work is being carried out in trying to close the performance gap between expected and realised energy savings following energy efficiency work, but the gap should not be expected to close entirely. The results of building modelling should be interpreted by a competent professional with an understanding of the limitations of building modelling. When making energy efficiency retrofit recommendations, factors beyond the thermodynamic limits of the model should be taken into consideration such as household practices and suitability of energy efficiency technologies and measures for different types of people. Only then can the greatest levels of energy savings be attained whilst also delivering the desired levels of energy service.

#### **8.1.4 Value of energy service perspective for retrofit challenge**

Through the work of this thesis, three main contributions have been made towards highlighting the value which the energy service perspective can have for the retrofit challenge:

- **The use of metrics for comparison of service demanded and delivered**

An aim of this work was to identify a service unit by which energy service efficiency could be compared for different energy efficiency technologies and measures. The difficulty in doing so stemmed from the fact that energy savings enabled by a change in key parameter depend on the size, shape and configuration of a house, as well as the pattern of demand. The technologies work in combination and therefore cannot be individually compared based on the energy service efficiency concept as illustrated in equation (4-2). Instead, it has been deemed more suitable to consider energy service demand and delivery in terms of the broader requirement of the household and in the case of heating thermal comfort, this was defined by the temperature required throughout the home at different times of day whilst occupied.

- **Requirement on building models to better represent how service is delivered**

The discrepancy illustrated in Figure 6-3, between a temperature profile generated by a typical heat balance model and a measured temperature profile, is expected to be characteristic of similar modelling approaches using dynamic simulation approaches. In steady state simulation models, there is no facility at all to model the resulting temperature profile and therefore the delivery of service cannot be compared in this way. The work within Chapter 6 of this thesis has demonstrated the benefits afforded by an enhanced model which more closely replicates a heating system within a home.

Generation of a visual temperature profile allows for the dynamics of the service delivery to be compared. Further calculation of a single metric, such as the heating comfort gap in



this work, allows for service delivery to be compared to other energy services or further metrics such as cost or CO<sub>2</sub>. Although other building models do generate thermal comfort satisfaction as an output, this is only reliable if the dynamic temperature changes throughout the day are well represented.

In order to develop this application of the energy service concept, further validation work is required. Model validation would involve more in-depth comparison between modelled and measured temperature profile to confirm the success with which the model is replicating a real home environment. The aim should not necessarily be calibration, as calibration to one building will not necessarily mean it is well matched to other buildings. Instead, the accuracy of the modelling should be understood and the uncertainty of the results be considered within resulting analysis.

- **Inclusion of suitability to different types of people to enable full potential of energy efficiency measures (EEMs) to be realised**

Motivated by Nørgård's (2000) extension of the energy system through energy service to welfare satisfaction, a further application of this work to energy service concept has been the inclusion of suitability of EEMs to households. The consideration of archetypes according to motivation and technical competency has demonstrated this application within this thesis. Such a consideration of suitability of EEMs to householders could be included within building modelling or interpretation of model results, but it requires an understanding of the householder within the home which is being considered for retrofit. This step change to considering the building as a home and not just a house is fundamental to the adoption of the energy service concept. By including more aspects of household preference, behaviour or habit, and competency, the use of energy can be better situated within everyday practices and retrofit recommendations will be more appropriate.

## 8.2. Policy recommendations

The decline in funding for energy efficiency retrofit in recent years has coincided with a reduction in the rate of adoption of energy efficiency technologies, but the work of this thesis has shown that energy efficiency retrofit can contribute to energy and CO<sub>2</sub> emission savings and improved delivery of heating thermal comfort to homes. Therefore, with the removal of the Green Deal as the major energy efficiency programme, additional policy support is required to ensure that energy efficiency measures continue to be implemented.

Without such support, the rate of energy efficiency improvement to the UK building stock is likely to reduce and the UK will face difficulty in achieving the ambitious targets to reduce greenhouse gas emissions to 80 % of 1990 levels by 2050.

Policy recommendations can be made from this work which focus upon the policy support for energy efficiency technologies, inclusion of energy service approach within building models and the opportunities for the smart meter roll-out to give householders a greater understanding of the energy which they are using.

- Insulation and improvement of passive system have been shown to be the best way to reduce energy consumption and deliver heating thermal comfort. Boiler improvements have also demonstrated to deliver considerable energy savings for all types of occupancy patterns.
  - Funding needs to continue to be available for those for whom financial barriers exist. It is also recommended that assistance is provided to householders to also overcome non-financial barriers, such as help to clear loft spaces and information about reliable tradespeople.
  - Training and accreditation for installers of energy efficiency measures would ensure that installations maintain a high level required for delivering a good energy performance. Householders would then be able to look out for the accreditation mark when arranging energy efficiency work, as a way to overcoming the difficulties of arranging retrofit work. Such an accreditation was developed through the Green Deal and this training and certification should continue to be promoted to trades people.
  - The legacy of the UK's poor housing stock has become a burden and the challenge of improving the UK's homes will continue for the coming decades. It is recommended that the energy efficiency improvement of homes should be treated as a national infrastructure project rather than individual requirements of householders. Such a recommendation has been advocated by [a range of groups]
- Heating controls were shown to have good comparable energy savings to larger measures and the barriers of cost are lower than for passive system and conversion device improvements.
  - It is therefore recommended that DECC's Smarter Heating Controls Research Program continues, and that the capabilities of advanced heating controls continue to be promoted.

- In order to overcome the poor performance of heating thermal comfort delivery by advance zonal heating control, it is recommended that advanced capabilities extend to all room thermostats communicating with the boiler.
- Heating controls are recommended predominantly to those households motivated by cost or CO<sub>2</sub> emission savings as a play-off exists between these household motivations and whether any energy savings are made.
- Current energy efficiency ratings have been criticised in literature for reflecting the economic performance of homes rather than the energy and carbon efficiency of homes. The energy service approach discussed in this thesis could provide a basis for energy efficiency ratings to be made based on the service being delivered.
  - Coupled with information about household occupancy, the energy service efficiency rating of the home could be calculated based on level of service demanded, giving a better reflection of how the use of the house is contributing to CO<sub>2</sub> emissions.
  - If the service delivery of heating thermal comfort can be included in the building modelling undertaken for the rating, the energy service efficiency of predicted service delivery could be calculated and compared for different technology options.
- Greater transparency about energy use afforded by smart meters could facilitate a shift in focus from energy consumption to energy service delivery. The UK's smart meter roll out could help to promote this greater level of energy awareness.
  - Disaggregation of energy data can be used to partition energy consumption to each end use, such that the gas and electricity required to deliver each energy service can be monitored. Following the energy efficiency retrofit, the change in energy consumption for a specific energy service could then be analysed and this could further enable the evaluation of how technologies and measures contribute to low carbon energy service.
  - There is potential for additional monitors to be linked up to the smart meter home system, and by linking up temperature sensors, the delivery of thermal comfort could also be evaluated following energy efficiency retrofit.
  - The availability of high resolution energy data could enable a better linkage between the behaviour of people and the energy they use, and therefore

provide transparency about how choices of the energy service level affect the cost of energy or the environmental impact of a household. Security and privacy of data is of great importance when considering how household energy data is to be used and appropriate measures should be put in place to allow for researchers to access data with permission whilst not infringing people's confidentiality.

## **8.3. Recommendations for future work**

### **8.3.1 Building model results to include range of savings based on household attributes**

In Chapters 4, 5 and 6, results were predominantly presented as distinct values, based on best available data of model inputs. For each model variable, a single value for modelling has been assumed, but in reality the value exists between expected limits. A range of results between upper and lower bounds would be more representative and provide better information as a model output as illustrated in Figure 5-10. A range of possible results could be generated by running the model using the upper and lower limits of each model input value, and a model interface could allow adjustment of these ranges for more precise results. Beyond a single range bar, the model could run with every configuration and all results could be plotted on the graph within the limits of the range of savings. By giving more information about the range of uncertainty, long term savings could be more appropriately predicted for calculations of financial cost, such as for a new Green Deal type policy or a DESCo type business model (as discussed in section 7.3.1.2 and further in section 8.3.2 below) or for CO<sub>2</sub> savings (such as for Energy Company Obligation calculations and regulations).

### **8.3.2 Development of domestic energy service company business model**

As discussed in section 7.3.1.2, the present work has contributed to the potential development of a domestic energy service company (DESCo) business model, but further work is required to explore such potential further. The focus of this thesis has been limited to building modelling, which would be a necessary part of a DESCo building model in predicting the energy savings and service delivery of potential energy efficiency interventions. Some validation has been undertaken of both the energy saving calculations in Chapter 5 and the temperature profile of the enhanced model in Chapter 6. However,

further empirical work could be undertaken to test the predictions of the model against the performance of technologies in real homes. This would preferably be undertaken through empirical measurements of both energy savings and service level before and after energy efficiency interventions. Such data collection would enable calculation of accurate energy savings and could be used to ensure that the service level, as measured by temperature profile and heating comfort gap metric, are not compromised.

Alongside validation of energy saving and energy service level predictions, an additional important aspect is the economic analysis of how a DESCo business model could work. Ideally the service would be sold as a guaranteed internal temperature for specified periods throughout the day. Cheaper “tariffs” could be offered which allow greater flexibility in the service delivery and higher values of heating comfort gap. This way, occupants could choose their contract based on their preference for ‘cost’ or ‘comfort’.

A main requirement for developing the DESCo business model is to find ways of managing risk and make a financial return whilst ensuring the business prospect is financially attractive to potential customers.

#### **8.3.3 Analysis of exergy efficiency**

Beyond energy efficiency, which is based on the first law of thermodynamics, exergy efficiency is based on the second law of thermodynamics. Exergy is a measure of the quality or usefulness of energy, or the potential of a system of flow to cause change (Rosen et al. 2008). It combines the thermodynamic properties of energy and entropy and the measure of exergetic efficiency can give a better indication of waste within a system than the more commonly used term energy efficiency. The conversion of energy carriers through the energy chain results in loss of exergy at each stage, and some conversions are less exergy efficient than others. For example, the use of high exergy electricity to produce low exergy low-grade heat is a particularly low exergy efficiency conversion. Exergy efficiency analysis has been included in a wide range of studies such as exergy analysis of the UK energy system (Hammond & Stapleton 2001; Brockway et al. 2014), and exergy efficiency of sustainable technologies (Rosen et al. 2008; Hepbasli 2008; Xiaowu & Ben 2005).

The comparison of technological approaches to energy service efficiency within the present work could be developed further by considering exergy within the full energy chain and therefore give further insights into the best approaches to energy use for heating thermal comfort and other energy services.

## 8.4. Final remarks

The motivation for this thesis was to contribute to an understanding of measures needed for climate change mitigation. Due to its large contribution to energy demand and greenhouse gas emissions, domestic energy consumption was identified as the focus and the significant retrofit challenge faced by the UK in particular narrowed this focus to existing buildings. The energy service concept was identified as an alternative perspective for the energy system which can shift the focus of energy planning from an unlimited supply side to a consideration of what people actually want from their energy.

Overall, the greatest energy savings identified were for full passive system improvement, at a level of just over 30 % energy reduction. These savings were predicted based on conservative values of improved building fabric thermal resistance which represent the performance of building retrofit currently. However, this is not sufficient to answer the significant retrofit challenge outlined in the introduction in which the UK's building stock will need to be zero carbon by 2050. In the reality of the coming decades, building energy policy therefore requires a step change in either the quality and standard of building fabric retrofit, de-carbonisation of final energy or an increased rate of replacement house building at high levels of energy performance. Unfortunately, the current direction of policy is reducing support for building retrofit and low carbon energy generation, and new building of houses is not sufficient to supply the current rate of demand, let alone contribute to replacing a greater proportion of existing buildings. The service demand perspective provides another opportunity for reducing energy demand by considering sufficiency alongside energy efficiency. Whilst improved energy efficiency addressed energy wastage, it does not give space to question whether the level of service demanded and delivered is equitable. A change in the level of energy service which people expect, such as smaller spaces heated for a shorter amount of time, would lead to greater energy conservation.

We are at a pivotal time globally in respect of acceptable levels of greenhouse gas emissions and the agreement made at the COP21 UN Climate Conference in Paris in December 2015 to limit global average temperature rise to 2 °C is not seen as ambitious enough. With a greater use of the energy service perspective and the introduction of demand orientated policies, there is potential for breaking the link between development, lifestyles and carbon emissions. An energy service approach in the coming decades can help us to link up the energy we use to the useful service it is delivering for us and the impact this is having on the environment. This improved energy and carbon literacy may be a crucial factor to enabling the right choices to be made to change our lifestyles to be more sustainable.

# References

- Abaza, H., 2008. An Interactive Design Advisor for Energy Efficient Buildings. *Journal of Green Building*, 3(1), pp.112–125.
- Aerts, D., Minnen, J., Glorieux, I., Wouters, I. & Descamps, F., 2014. A method for the identification and modelling of realistic domestic occupancy sequences for building energy demand simulations and peer comparison. *Building and Environment*, 75, pp.67–78.
- Alcott, B., 2005. Jevons' paradox. *Ecological Economics*, 54(1), pp.9–21.
- Alcott, B., 2008. The sufficiency strategy: Would rich-world frugality lower environmental impact? *Ecological Economics*, 64(4), pp.770–786.
- Al-Homoud, M.S., 2001. Computer-aided building energy analysis techniques. *Building and Environment*, 36(4), pp.421–433.
- Allcott, H., 2011. Social norms and energy conservation. *Journal of Public Economics*, 95(9-10), pp.1082–1095.
- Anastaselos, D., Giama, E. & Papadopoulos, A.M., 2009. An assessment tool for the energy, economic and environmental evaluation of thermal insulation solutions. *Energy and Buildings*, 41(11), pp.1165–1171.
- Anderson, B.R., Clarke, J.A., Baldwin, R. & Milbank, N.O., 1985. *BREDEM — BRE Domestic Energy Model: background, philosophy and description*, Watford.
- Ardente, F., Beccali, M., Cellura, M. & Mistretta, M., 2008. Building energy performance: A LCA case study of kenaf-fibres insulation board. *Energy and Buildings*, 40(1), pp.1–10.
- Atzeri, A.M., Cappelletti, F. & Gasparella, A., 2014. Assessment Of Long-Term Visual And Thermal Comfort And Energy Performance In Open-Space Offices With Different Shading Devices. In *International High Performance Buildings Conference*.
- Audenaert, A., Briffaerts, K. & Engels, L., 2011. Practical versus theoretical domestic energy consumption for space heating. *Energy Policy*, 39(9), pp.5219–5227.
- Ayres, R.U., 1995. Life cycle analysis: A critique. *Resources, Conservation and Recycling*, 14(3-4), pp.199–223.
- Ayres, R.U., 1998. Technological Progress: A Proposed Measure. *Technological Forecasting and Social Change*, 59, pp.213–233.
- Baetens, R., Jelle, B.P. & Gustavsen, A., 2011. Aerogel insulation for building applications: A state-of-the-art review. *Energy and Buildings*, 43(4), pp.761–769.
- Baker, P., 2011. *Technical Paper 10: U-values and traditional buildings*, Glasgow.
- Bartiaux, F., Gram-Hanssen, K., Fonseca, P., Ozoliņa, L. & Christensen, T.H., 2014. A practice–theory approach to homeowners' energy retrofits in four European areas. *Building Research & Information*, 42(4), pp.525–538.
- Bates, O. & Hazas, M., 2013. Exploring the Hidden Impacts of HomeSys : Energy and Emissions of Home Sensing and Automation. In *UbiComp'13*. Zurich, Switzerland, pp. 809–814.
- Behar, C. & Chiu, L.F., 2013. Ventilation in energy efficient UK homes : A user experience of innovative technologies. In *ECEEE Summer Study proceedings 2013*. pp. 2389–2399.
- Beizaee, A., Allinson, D., Lomas, K.J., Foda, E. & Loveday, D.L., 2015. Measuring the Potential of Zonal Space Heating Controls to Reduce Energy use in UK homes: the case of un-furbished 1930s dwellings. *Energy and Buildings*, 92, pp.29–44.

## References

- Bertoldi, P., Rezessy, S. & Vine, E., 2006. Energy service companies in European countries: Current status and a strategy to foster their development. *Energy Policy*, 34(14), pp.1818–1832.
- Blight, T.S. & Coley, D. a., 2013. Sensitivity analysis of the effect of occupant behaviour on the energy consumption of passive house dwellings. *Energy and Buildings*, 66, pp.183–192.
- Bosseboeuf, D., Chateau, B. & Lapillonne, B., 1997. Cross-country comparison on energy efficiency indicators: the on-going European effort towards a common methodology. *Energy Policy*, 25(7-9), pp.673–682.
- Bradley, D. & Kummert, M., 2005. New evolutions in TRNSYS – a selection of version 16 features. In *9th International IBPSA Conference*. Montreal, Canada, pp. 107–114.
- Brager, G.S. & de Dear, R.J., 1998. Thermal adaptation in the built environment : a literature review. *Energy and Buildings*, 27, pp.83–96.
- Brischke, L.-A., Leuser, L., Baedeker, C., Lehmann, F. & Thomas, S., 2015. Energy sufficiency in private households enabled by adequate appliances. In *ECEEE Summer Study proceedings 2015*. pp. 1571–1582.
- Bristol Green Doors, 2013. Bristol Green Doors Passive Retrofit Case Study: Easton Road, BS5. *Bristol Green Doors Case Study*. Available at: [http://www.bristolgreendoors.org/sites/bristolgreendoors.org/files/Easton\\_Road\\_Case\\_Study.pdf](http://www.bristolgreendoors.org/sites/bristolgreendoors.org/files/Easton_Road_Case_Study.pdf) [Accessed October 23, 2013].
- Brockway, P.E., Barrett, J.R., Foxon, T.J. & Steinberger, J.K., 2014. Divergence of trends in US and UK aggregate exergy efficiencies 1960-2010. *Environmental science & technology*, 48(16), pp.9874–81.
- Brown, P. & Swan, W., 2012. Technology, users and everyday lives: the installation and use of heating systems and energy efficient technologies in UK households. In *MILEN International Conference: Advancing the research and policy agendas on sustainable energy and the environment*. University of Oslo.
- BSi, 2005. BS 5250:2002 Code of practice for control of condensation in buildings.
- BusinessGreen, 2013. “Conservatory tax” revival hopes thwarted by court ruling. *The Guardian*.
- Caird, S., Roy, R. & Herring, H., 2008. Improving the energy performance of UK households: Results from surveys of consumer adoption and use of low- and zero-carbon technologies. *Energy Efficiency*, 1(2), pp.149–166.
- Cairncross, F., 1997. *Death of Distance: how the communications revolution will change our lives*, Harvard Business School Press.
- Carlucci, S. & Pagliano, L., 2012. A review of indices for the long-term evaluation of the general thermal comfort conditions in buildings. *Energy and Buildings*, 53, pp.194–205.
- Carlucci, S., Pagliano, L. & Sangalli, A., 2014. Statistical analysis of the ranking capability of long-term thermal discomfort indices and their adoption in optimization processes to support building design. *Building and Environment*, 75, pp.114–131.
- CCC, 2010. *The Fourth Carbon Budget: Reducing emissions through the 2020s*, London.
- Chiu, L.F., Lowe, R., Raslan, R., Altamirano-Medina, H. & Wingfield, J., 2014. A socio-technical approach to post-occupancy evaluation: interactive adaptability in domestic retrofit. *Building Research & Information*, 42(5), pp.574–590.
- Christensen, T.H., Gram-Hanssen, K., de Best-Waldhober, M. & Adjei, A., 2014. Energy retrofits of Danish homes: is the Energy Performance Certificate useful? *Building Research & Information*, 42(4), pp.489–500.
- CIBSE, 2006a. *CIBSE Guide A: Environmental Design*, London.
- CIBSE, 2006b. *Degree-days : theory and application (TM41:2006)*, London: CIBSE Publications.
- CIBSE, 2012. *Low and Zero Carbon Energy Technologies: CIBSE Mid Career College Courses (Course material)*.
- Combe, N., Harrison, D., Dong, H., Craig, S. & Gill, Z.M., 2011. Assessing the number of users who are excluded by domestic heating controls. *International Journal of Sustainable Engineering*, 4(1), pp.84–92.



- Consumer Focus, 2012. *Consumers and domestic heating controls: a literature review*, London.
- Cooper, J.S., 2002. LCA Methodology with Case Studies: Specifying Functional Units and Reference Flows for Comparable Alternatives. , (1), pp.337–349.
- Cravioto, J., Yamasue, E., Okumura, H. & Ishihara, K.N., 2014. Energy service satisfaction in two Mexican communities: A study on demographic, household, equipment and energy related predictors. *Energy Policy*, 73, pp.110–126.
- Crawley, D.B., Hand, J.W., Kummert, M. & Griffith, B.T., 2008. Contrasting the capabilities of building energy performance simulation programs. *Building and Environment*, 43(4), pp.661–673.
- Crowley, J., 2001. *The Invention of Comfort*, Baltimore: Johns Hopkins University Press.
- Cullen, J.M. & Allwood, J.M., 2010a. The efficient use of energy: Tracing the global flow of energy from fuel to service. *Energy Policy*, 38(1), pp.75–81.
- Cullen, J.M. & Allwood, J.M., 2010b. Theoretical efficiency limits for energy conversion devices. *Energy*, 35(5), pp.2059–2069.
- Cullen, J.M., Allwood, J.M. & Borgstein, E.H., 2011. Reducing Energy Demand: What Are the Practical Limits? *Environmental science & technology*, pp.1711–1718.
- D'Oca, S., Fabi, V., Corgnati, S.P. & Andersen, R.K., 2014. Effect of thermostat and window opening occupant behavior models on energy use in homes. *Building Simulation*, 7(6), pp.683–694.
- Daly, H.E., 1974. The Economics of the Steady State. *The American Economic Review*, 64(2).
- Daniel, L., Soebarto, V. & Williamson, T., 2015. House energy rating schemes and low energy dwellings: The impact of occupant behaviours in Australia. *Energy and Buildings*, 88, pp.34–44.
- Darby, S., 2007. Enough is as good as a feast – sufficiency as policy. *Energy Policy*, pp.111–120.
- DCLG, 2014. *English Housing Survey: Energy Efficiency of English Housing 2012.*, London.
- DCLG, 2015. *English Housing Survey: Energy efficiency of English housing 2013*, London.
- DCLG, 2012. *English Housing Survey: Headline Report 2010-11*, London.
- DCLG, 2010. *English Housing Survey: Housing stock report 2008*, London.
- de Dear, R.J., 2004. Thermal comfort in practice. *Indoor air*, 14(Suppl 7), pp.32–39.
- DECC, 2014a. *DECC Energy Consumption in the UK: Domestic data tables (2014 update)*,
- DECC, 2014b. *Energy Consumption in the UK (2014) - Chapter 3: Domestic energy consumption in the UK between 1970 and 2013*, London.
- DECC, 2013a. *National Energy Efficiency Data-Framework (NEED) - Part II: Impact of Energy Efficiency Measures in Homes*, London.
- DECC, 2014c. *National Energy Efficiency Data-Framework (NEED): Summary of analysis using the National Energy Efficiency Data Framework*, London.
- DECC, 2014d. *Process Evaluation of the Warm Front Scheme*, London.
- DECC, 2015. Smarter heating controls research program. , pp.1–11.
- DECC, 2013b. *Statistical Release: Experimental Statistics. Estimates of Home Insulation Levels in Great Britain: July 2013*, London.
- DECC, 2012a. *The Energy Efficiency Strategy: The Energy Efficiency Opportunity in the UK*, London: HM Government.
- DECC, 2011. *UK Report on Articles 4 and 14 of the EU End-use Efficiency and Energy Services Directive (ESD)*, London.
- DECC, 2012b. *Which energy efficiency improvements qualify for Green Deal Finance?*, London.
- DEFRA, 2008. *A framework for pro-environmental behaviours*,
- DEFRA, 2015. UK Government conversion factors for Company Reporting. Available at: <http://www.ukconversionfactorscarbonsmart.co.uk/> [Accessed December 16, 2015].
- Demirel, Y., 2012. *Energy: Green Energy and Technology*, London: Springer London.

## References

- Deurinck, M., Saelens, D. & Roels, S., 2012. Assessment of the physical part of the temperature takeback for residential retrofits. *Energy and Buildings*, 52, pp.112–121.
- Dowson, M., Poole, A., Harrison, D. & Susman, G., 2012. Domestic UK retrofit challenge: Barriers, incentives and current performance leading into the Green Deal. *Energy Policy*, 50, pp.294–305.
- Duran, Özlem, 2013. *Empirical validation of 4 typical sample houses by sensitivity analysis (MRes Dissertation)*. Loughborough University.
- Eguaras-Martínez, M., Vidaurre-Arbizu, M. & Martín-Gómez, C., 2014. Simulation and evaluation of Building Information Modeling in a real pilot site. *Applied Energy*, 114, pp.475–484.
- Ekwevugbe, T., 2013. *Advanced Occupancy Measurement Using Sensor Fusion*. De Montford University.
- Ellsworth-krebs, K., 2014. Homes don't use energy people do : Developing a new conceptual understanding of low-energy living. In *BEHAVE2014 – Behavior and Energy Efficiency Conference*. Oxford, pp. 1–9.
- Ellsworth-Krebs, K., Reid, L. & Hunter, C.J., 2015. Home-ing in on domestic energy research: “House,” “home,” and the importance of ontology. *Energy Research & Social Science*, 6, pp.100–108.
- Elsharkawy, H. & Rutherford, P., 2015. Retrofitting social housing in the UK: Home energy use and performance in a pre-Community Energy Saving Programme (CESP). *Energy and Buildings*, 88, pp.25–33.
- EST, 2006. *GPG 268 Energy efficient ventilation in dwellings – a guide for specifiers*,
- EST, 2013. Thermostats and controls. *Energy Saving Trust*. Available at: <http://www.energysavingtrust.org.uk/home-energy-efficiency/thermostats-and-controls> [Accessed November 3, 2014].
- European Standard, 2006. *EN 15251 (2006): Indoor environmental input parameters for design and indoor air quality, thermal environment, lighting and acoustics*,
- Fabi, V., Andersen, R.V. & Corgnati, S.P., 2013. Influence of occupant's heating set-point preferences on indoor environmental quality and heating demand in residential buildings. *HVAC&R Research*, 19, pp.635–645.
- Fabi, V., Andersen, R.V., Corgnati, S.P. & Olesen, B.W., 2013. A methodology for modelling energy-related human behaviour: Application to window opening behaviour in residential buildings. *Building Simulation*, 6(4), pp.415–427.
- Fabi, V., Andersen, R.V., Corgnati, S.P. & Olesen, B.W., 2012. Occupants' window opening behaviour: A literature review of factors influencing occupant behaviour and models. *Building and Environment*, 58, pp.188–198.
- Fanger, P.O., 1967. Calculation of thermal comfort, Introduction of a basic comfort equation. *ASHRAE transactions*, 73(2), pp.III–4.
- Firth, S., Lomas, K.J. & Wright, a. J., 2010. Targeting household energy-efficiency measures using sensitivity analysis. *Building Research & Information*, 38(1), pp.25–41.
- Fouquier, A., Robert, S., Suard, F., Stéphan, L. & Jay, A., 2013. State of the art in building modelling and energy performances prediction: A review. *Renewable and Sustainable Energy Reviews*, 23, pp.272–288.
- Fouquet, R. & Pearson, P.J.G., 2006. Seven Centuries of Energy Services : The Price and Use of Light in the United Kingdom ( 1300-2000 ) 1. *Energy*, 27(1), pp.139–177.
- Friege, J. & Chappin, E., 2014. Modelling decisions on energy-efficient renovations: A review. *Renewable and Sustainable Energy Reviews*, 39, pp.196–208.
- Galvin, R. & Sunikka-Blank, M., 2014. The UK homeowner-retrofitter as an innovator in a socio-technical system. *Energy Policy*, 74, pp.655–662.
- Gauthier, S. & Shipworth, D., 2014. The gap between what is said and what is done : a method for distinguishing reported and observed responses to cold thermal discomfort. , (April), pp.10–13.

- Gazis, E. & Harrison, G.P., 2011. Life Cycle Energy and Carbon Analysis of Domestic Combined Heat and Power Generators. , (June), pp.19–23.
- Gifford, R., Kormos, C. & McIntyre, A., 2011. Behavioral dimensions of climate change: Drivers, responses, barriers, and interventions. *Wiley Interdisciplinary Reviews: Climate Change*, 2(6), pp.801–827.
- Gilchrist, K. & Craig, T., 2014. *Home energy efficiency - review of evidence on attitudes and behaviours*, Edinburgh.
- Gill, Z.M., Tierney, M.J., Pegg, I.M. & Allan, N., 2010. Low-energy dwellings: the contribution of behaviours to actual performance. *Building Research & Information*, 38(5), pp.491–508.
- GLA, 2012. *London plan 2011 Implementation framework. Housing: supplementary planning guidance*, London.
- Glorieux, I. & Minnen, J., 2008. Belgisch tijdsbudgetonderzoek. Available at: [www.time-use.be](http://www.time-use.be).
- Goldstein, N.J., Cialdini, R.B. & Griskevicius, V., 2008. A Room with a Viewpoint: Using Social Norms to Motivate Environmental Conservation in Hotels. *Journal of Consumer Research*, 35(3), pp.472–482.
- Gram-Hanssen, K., 2003. Boligers energiforbrug—sociale og tekniske forklaringer på forskelle. By og byg resultater 029. Statens Byggeforskningsinstitut.
- Gram-Hanssen, K., 2004. Domestic electricity consumption— consumers and appliances. In L. Reisch & I. Røpke, eds. *The ecological economics of consumption*. Cheltenham: Edward Elgar Publishing.
- Gram-Hanssen, K., 2012. Efficient technologies or user behaviour, which is the more important when reducing households' energy consumption? *Energy Efficiency*, 6(3), pp.447–457.
- Gram-Hanssen, K., 2014. Existing buildings – Users, renovations and energy policy. *Renewable Energy*, 61, pp.136–140.
- Gram-Hanssen, K., 2010. Residential heat comfort practices: understanding users. *Building Research & Information*, 38(2), pp.175–186.
- Gram-Hanssen, K., 2011. Understanding change and continuity in residential energy consumption. *Journal of Consumer Culture*, 11(1), pp.61–78.
- de Groot, E., Spiekman, M. & Opstelten, I., 2008. Dutch Research into User Behaviour in Relation to Energy Use of Residences. In *25th Conference on Passive and Low Energy Architecture*. Dublin.
- Groscurth, H., Bruckner, T. & Kummel, R., 1995. Modeling of energy-services supply systems. *Energy*, 20(9), pp.941–958.
- Guerra-Santin, O., 2011. Behavioural Patterns and User Profiles related to energy consumption for heating. *Energy and Buildings*, 43(10), pp.2662–2672.
- Guerra-Santin, O., 2012. Occupant behaviour in energy efficient dwellings: evidence of a rebound effect. *Journal of Housing and the Built Environment*, 28(2), pp.311–327.
- Guerra-Santin, O. & Itard, L., 2010. Occupants' behaviour: determinants and effects on residential heating consumption. *Building Research & Information*, 38(3), pp.318–338.
- Guerra-Santin, O., Itard, L. & Visscher, H., 2009. The effect of occupancy and building characteristics on energy use for space and water heating in Dutch residential stock. *Energy and Buildings*, 41(11), pp.1223–1232.
- Guertler, P., 2012. Can the Green Deal be fair too? Exploring new possibilities for alleviating fuel poverty. *Energy Policy*, 49, pp.91–97.
- Gupta, C.L., 1970. A Systematic Approach to Optimum Thermal Design. *Building Science*, 5(3-4), pp.165–173.
- Gupta, R., Gregg, M., Passmore, S. & Stevens, G., 2015. Intent and outcomes from the Retrofit for the Future programme: key lessons. *Building Research & Information*, 43(4), pp.435–451.
- Gustavsson, L. & Joelsson, A., 2010. Life cycle primary energy analysis of residential buildings.

## References

- Energy and Buildings*, 42(2), pp.210–220.
- Haas, R., 1997. Energy efficiency indicators in the residential sector. *Energy Policy*, 25, pp.789–802.
- Haas, R., Nakićenović, N., Ajanovic, A., Faber, T., Kranzl, L., Müller, A. & Resch, G., 2008. Towards sustainability of energy systems: A primer on how to apply the concept of energy services to identify necessary trends and policies. *Energy Policy*, 36(11), pp.4012–21.
- Haines, V. & Mitchell, V., 2014. A persona-based approach to domestic energy retrofit. *Building Research & Information*, 42(4), pp.462–476.
- Hammond, G.P. & Jones, C.I., 2011a. Embodied Carbon – The inventory of carbon and energy. BG 10/2011. ISBN 978 0 86022 703 8.
- Hammond, G.P. & Jones, C.I., 2011b. Inventory of Carbon & Energy (ICE).
- Hammond, G.P. & Stapleton, a J., 2001. Exergy analysis of the United Kingdom energy system. *Proceedings of the Institution of Mechanical Engineers, Part A: Journal of Power and Energy*, 215(2), pp.141–162.
- Hammond, G.P. & Winnett, a. B., 2006. Interdisciplinary perspectives on environmental appraisal and valuation techniques. *Proceedings of the ICE - Waste and Resource Management*, 159(3), pp.117–130.
- Hansford, P., 2015. *Solid Wall Insulation: Unlocking Demand and Driving Up Standards*, London.
- Harris, J., Diamond, R., Iyer, M., Payne, C., Blumstein, C. & Siderius, H.P., 2008. Towards a sustainable energy balance: Progressive efficiency and the return of energy conservation. *Energy Efficiency*, 1(3), pp.175–188.
- Harris, J., Diamond, R., Iyer, M., Payne, C., Blumstein, C. & Siderius, H.-P., 2007. *Towards a Sustainable Energy Balance : Progressive Efficiency and the Return of Energy Conservation*,
- Harvey, D., 2010. *Energy and the New Reality 1-Energy Efficiency and the Demand for Energy Services*, London: Earthscan.
- Hee, L.K. & Hyuck, Y.J., 2010. A Study on the Estimation Model of the Amount of the Energy Consumption and CO2 Emission according to the Apartment Heating Type. *Journal of the Architectural Institute of Korea Planning & Design*, 26(5), pp.355–362.
- Henley, J., 2015. World set to use more energy for cooling than heating. *The Guardian*.
- Hepbasli, A., 2008. A key review on exergetic analysis and assessment of renewable energy resources for a sustainable future. *Renewable and Sustainable Energy Reviews*, 12(3), pp.593–661.
- Herring, H., 2006. Energy efficiency—a critical view. *Energy*, 31(1), pp.10–20.
- Higginson, S., Mckenna, E., Thomson, M. & Road, A., 2014. Can practice make perfect (models)? Incorporating Social Practice Theory into Quantitative Energy Demand Models. In *BEHAVE2014 – Behavior and Energy Efficiency Conference*. Oxford.
- Higginson, S., Richardson, I. & Thomson, M., 2011. Energy use in the context of behaviour and practice : the interdisciplinary challenge in modelling flexible electricity demand. In *Energy and People: Futures, Complexity and Challenges, 20-21 September*. Oxford University, pp. 20–21.
- Hiller, C., 2012. Influence of residents on energy use in 57 Swedish houses measured during four winter days. *Energy and Buildings*, 54, pp.376–385.
- HM Treasury, 2015. *Fixing the Foundations: Creating a more prosperous nation*, London.
- Höjer, M., Gullberg, A., Pettersson, R. & Ahlroth, S., 2011. *Images of the Future City: Time and Space For Sustainable Development*, Dordrecht: Springer.
- Hong, S.H., Gilbertson, J., Oreszczyn, T., Green, G. & Ridley, I., 2009. A field study of thermal comfort in low-income dwellings in England before and after energy efficient refurbishment. *Building and Environment*, 44(6), pp.1228–1236.
- van Hoof, J., 2008. Forty years of Fanger’s model of thermal comfort: comfort for all? *Indoor air*, 18(3), pp.182–201.
- Hormazabal, N., Gillott, M., Guzman, G. & Revell, G., 2009. The Effect of Technological

- User Control Systems on Occupants of Sustainable Energy Homes. , 1(June), pp.22–24.
- Houck, J. & Rickerson, W., 2009. The Sustainable Energy Utility (SEU) Model for Energy Service Delivery. *Bulletin of Science, Technology & Society*, 29(2), pp.95–107.
- Huebner, G.M., Cooper, J. & Jones, K., 2013. Domestic energy consumption—What role do comfort, habit, and knowledge about the heating system play? *Energy and Buildings*, 66, pp.626–636.
- Huebner, G.M., Hamilton, I., Chalabi, Z., Shipworth, D. & Oreszczyn, T., 2015. Explaining domestic energy consumption – The comparative contribution of building factors, socio-demographics, behaviours and attitudes. *Applied Energy*, 159, pp.589–600.
- Huebner, G.M., McMichael, M., Shipworth, D., Shipworth, M., Durand-Daubin, M. & Summerfield, A.J., 2013. The reality of English living rooms – A comparison of internal temperatures against common model assumptions. *Energy and Buildings*, 66, pp.688–696.
- Huebner, G.M., McMichael, M., Shipworth, D., Shipworth, M., Durand-Daubin, M. & Summerfield, A.J., 2015. The shape of warmth: temperature profiles in living rooms. *Building Research & Information*, 43(2), pp.185–196.
- Hughes, M., 2011. *A guide to the Cambridge Housing Model*, London.
- Hughes, M., Palmer, J., Cheng, V. & Shipworth, D., 2013. Sensitivity and uncertainty analysis of England’s housing energy model. *Building Research & Information*, 41(2), pp.37–41.
- Hunt, D.R.G. & Gidmant, M.I., 1982. A National Field Survey of House Temperatures. *Building and Environment*, 17(2), pp.107–124.
- IEA, 2008. *Energy Technologies Perspectives 2008*, Paris.
- Ingle, A., Moezzi, M., Lutzenhiser, L. & Diamond, R., 2014. Better home energy audit modelling: incorporating inhabitant behaviours. *Building Research & Information*, 42(4), pp.409–421.
- Intini, F. & Kühtz, S., 2011. Recycling in buildings: an LCA case study of a thermal insulation panel made of polyester fiber, recycled from post-consumer PET bottles. *The International Journal of Life Cycle Assessment*, 16(4), pp.306–315.
- ISO, 1997. ISO 13600:1997. Technical Energy Systems - Basic Concepts.
- Jack, R., Loveday, D., Allinson, D. & Lomas, K., 2015. Quantifying the Effect of Window Opening on the Measured Heat Loss of a Test House. *International SEEDS Conference 2015: Sustainable Ecological Engineering Design for Society, Leeds Beckett University, Leeds, UK, 17th-18th September 2015*.
- Jaffe, A.B. & Stavins, R.N., 1994. The Energy-efficiency Gap: What does it mean? *Energy Policy*, 22(10), pp.804–810.
- Jaggs, M. & Scivyer, C., 2009. *A practical guide to building airtight dwellings*,
- Jansen, J.C. & Seebregts, A.J., 2010. Long-term energy services security: What is it and how can it be measured and valued? *Energy Policy*, 38(4), pp.1654–1664.
- Jevons, W.S., 1865. The coal question: can Britain survive? In A. W. Flux, ed. *The Coal Question: An Inquiry Concerning the Progress of the Nation, and the Probable Exhaustion of Our Coal-mines*. New York: Augustus M. Kelley.
- Jochem, E., 2000. *Energy end-use efficiency (World Energy Assessment: Energy and the challenge of sustainability)*,
- Johnston, D., Farmer, D., Brooke-Peat, M. & Miles-Shenton, D., 2014. Bridging the domestic building fabric performance gap. *Building Research & Information*, (April 2015), pp.1–14.
- Johnston, D., Lowe, R. & Bell, M., 2005. An exploration of the technical feasibility of achieving CO<sub>2</sub> emission reductions in excess of 60 % within the UK housing stock by the year 2050. *Energy Policy*, 33(13), pp.1643–1659.
- Jonsson, D.K., 2005. The Nature of Infrasystem Services. *Journal of Infrastructure Systems*, 11(1), pp.2–8.
- Jonsson, D.K., Gustafsson, S., Wangel, J., Höjer, M., Lundqvist, P. & Svane, Ö., 2011. Energy at your service: highlighting energy usage systems in the context of energy efficiency

## References

- analysis. *Energy Efficiency*, 4(3), pp.355–369.
- Judson, E.P. & Maller, C., 2014. Housing renovations and energy efficiency: insights from homeowners' practices. *Building Research & Information*, 42(4), pp.501–511.
- Kahane, A., 1991. New perspectives for energy efficiency and system optimization. *Energy Policy*, 19(3), pp.199–201.
- Kane, T., 2013. *Indoor temperatures in UK dwellings: investigating heating practices using field survey data*. Loughborough University.
- Kane, T., Firth, S., Allinson, D., Irvine, K. & Lomas, K.J., 2010. Does the age of the residents influence occupant heating practice in UK domestic buildings? In *East Midlands Universities Association 2010 Conference - Perspectives in Society: Health, Culture and the Environment*. East Midlands Universities Association.
- Kane, T., Firth, S., Allinson, D., Irvine, K. & Lomas, K.J., 2011. Understanding occupant heating practices in UK dwellings. In *World Renewable Energy Congress 2011, 8-11 May*. Linköping, Sweden, pp. 1126 –1133.
- Kane, T., Firth, S., Lomas, K.J., Allinson, D. & Irvine, K., 2011. Variation of indoor temperatures and heating practices in uk dwellings. In *"Buildings Don't Use Energy, People Do?" – Domestic Energy Use and CO2 Emissions in Existing Dwellings, 28th June 2011*. Bath, pp. 1–10.
- Kelly, S., 2013. *Decarbonising the English residential sector: Modelling policies, technologies and behaviour within a heterogeneous building stock*. University of Cambridge.
- Kelly, S., Crawford-Brown, D. & Pollitt, M.G., 2012. Building performance evaluation and certification in the UK: Is SAP fit for purpose? *Renewable and Sustainable Energy Reviews*, 16(9), pp.6861–6878.
- Kelly, S., Shipworth, M., Shipworth, D., Gentry, M., Wright, A., Pollitt, M.G., Crawford-Brown, D. & Lomas, K.J., 2013. Predicting the diversity of internal temperatures from the English residential sector using panel methods. *Applied Energy*, 102, pp.601–621.
- Kneifel, J., 2010. Life-cycle carbon and cost analysis of energy efficiency measures in new commercial buildings. *Energy and Buildings*, 42(3), pp.333–340.
- Knoeri, C., Steinberger, J.K. & Roelich, K., 2015. End-user centred infrastructure operation: towards integrated end-use service delivery. *Journal of Cleaner Production*, pp.1–11.
- Korjenic, A. & Bednar, T., 2011. Impact of lifestyle on the energy demand of a single family house. *Building Simulation*, 4, pp.89–95.
- Kusenbach, M., 2003. Street Phenomenology. *Ethnography*, 4(3), pp.455–485.
- Li, F.G.N., Smith, A.Z.P., Biddulph, P., Hamilton, I.G., Lowe, R., Mavrogianni, A., Oikonomou, E., Raslan, R., Stamp, S., Stone, A., Summerfield, A.J., Veitch, D., Gori, V. & Oreszczyn, T., 2015. Solid-wall U -values: heat flux measurements compared with standard assumptions. *Building Research & Information*, 43(2), pp.238–252.
- Lightfoot, H.D., 2007. Understand the three different scales for measuring primary energy and avoid errors. *Energy*, 32(8), pp.1478–1483.
- Lomas, K.J., Bell, M.C., Firth, S., Gaston, J.K., Goodman, P., R, L.J., Namdeo, A., Rylatt, R.M., Allinson, D., Davies, G.Z., Edmondson, L.J., Galatioto, F., Brake, A.J., Guo, L., Hill, G., Irvine, K.N., Taylor, S.C. & Tiwary, A., 2010. *4M: Measurement, modelling, mapping and management the carbon footprint of UK cities*. Technical Report, Oxford.
- Lomas, K.J. & Kane, T., 2013. Summertime temperatures and thermal comfort in UK homes. *Building Research & Information*, 41(3), pp.259–280.
- Love, J., 2012. Mapping the impact of changes in occupant heating behaviour on space heating energy use as a result of UK domestic retrofit. In *Retrofit 2012*. Salford.
- Love, J., 2014. *Understanding the interactions between occupants, heating systems and building fabric in the context of energy efficient building fabric retrofit in social housing*. (PhD Thesis) University College London.
- Lovins, A.B., 1976. Energy Strategy - The road not taken? *Foreign Affairs*, pp.65–96.
- Lovins, A.B., 2011. *Reinventing Fire: Bold Business Solutions for the New Energy Era*, White river

- Junction, VT: Chelsea Green Publishing.
- Lowe, R., Chiu, L.F., Raslan, R. & Altamirano, H., 2011. *Retrofit insights: perspectives for an emerging industry report*, London.
- Lundgren, K. & Kjellstrom, T., 2013. Sustainability Challenges from Climate Change and Air Conditioning Use in Urban Areas. *Sustainability*, 5(7), pp.3116–3128.
- Ma, L., Allwood, J.M., Cullen, J.M. & Li, Z., 2012. The use of energy in China: Tracing the flow of energy from primary source to demand drivers. *Energy*, 40(1), pp.174–188.
- Macalister, T., 2015. UK solar panel subsidy cuts branded “huge and misguided.” *The Guardian*.
- Madsen, L.V., 2014. Can Comfort be Practised? In *BEHAVE2014 – Behavior and Energy Efficiency Conference*. Oxford.
- Magnier, L. & Haghghat, F., 2010. Multiobjective optimization of building design using TRNSYS simulations, genetic algorithm, and Artificial Neural Network. *Building and Environment*, 45(3), pp.739–746.
- Majcen, D., Itard, L. & Visscher, H., 2015. Statistical model of the heating prediction gap in Dutch dwellings: Relative importance of building, household and behavioural characteristics. *Energy and Buildings*, 105, pp.43–59.
- Mallaburn, P.S. & Eyre, N., 2014. Lessons from energy efficiency policy and programmes in the UK from 1973 to 2013. *Energy Efficiency*, 7(1), pp.23–41.
- Marino, A., Bertoldi, P., Rezessy, S. & Boza-Kiss, B., 2011. A snapshot of the European energy service market in 2010 and policy recommendations to foster a further market development. *Energy Policy*, 39(10), pp.6190–6198.
- Marshall, E., 2015. Use of smart metering data to enhance the delivery of energy efficiency policies. In *World Sustainable Energy Days, Young Researchers Conference*. Wels, Austria.
- McKenna, E., Krawczynski, M. & Thomson, M., 2015. Four-state domestic building occupancy model for energy demand simulations. *Energy and Buildings*, 96, pp.30–39.
- McLoughlin, F., Duffy, A. & Conlon, M., 2012. Characterising domestic electricity consumption patterns by dwelling and occupant socio-economic variables: An Irish case study. *Energy and Buildings*, 48(July 2009), pp.240–248.
- de Meester, T., Marique, A.-F., De Herde, A. & Reiter, S., 2013. Impacts of occupant behaviours on residential heating consumption for detached houses in a temperate climate in the northern part of Europe. *Energy and Buildings*, 57, pp.313–323.
- Modi, V., McDade, S., Lallement, D. & Saghir, J., 2005. *Energy Services for the Millennium Development Goals*, New Haven, CT.
- Morris-Marsham, C., 2012. *Delivering energy efficiency in the UK through Domestic Energy Service Companies (DESCos) (MRes dissertation)*. Loughborough University.
- Motuziene, V. & Vilutiene, T., 2013. Modelling the Effect of the Domestic Occupancy Profiles on Predicted Energy Demand of the Energy Efficient House. *Procedia Engineering*, 57, pp.798–807.
- Munton, A.G., Wright, A.J., Mallaburn, P. & Boait, P., 2014. *How heating controls affect domestic energy demand: A Rapid Evidence Assessment*, London.
- Nakićenović, N., 1993. Energy Conversion, Conservation, and Efficiency. *Energy*, 18(5), pp.421–435.
- Nakićenović, N., Gilli, P.V. & Kurz, R., 1996. Regional and global exergy and energy efficiencies. *Energy*, 21(3), pp.223–237.
- Nakićenović, N., Grubler, A., Ishitani, H., Johansson, T.B., Marland, G. & Moreira, J.R., 1996. *Chapter B Energy Primer in Contribution of Working Group II to the Second Assessment Report of the Intergovernmental Panel on Climate Change*,
- Nørgård, J.S., 2000. Models of energy saving systems: the battlefield of environmental planning. *International Journal of Global Energy Issues*, 13, pp.102–122.
- Oldfield, P., 2015. UK scraps zero carbon homes plan. *The Guardian*.

## References

- ONS, 2014. *Characteristics of Home Workers, 2014*,
- ONS, 2013a. *Families and Households, 2013*,
- ONS, 2011. *Ownership of consumer durables increases into 2010*, London.
- ONS, 2013b. *Population Estimates for UK, England and Wales, Scotland and Northern Ireland, Mid-2013*,
- Oreszczyn, T., Hong, S.-H., Ridley, I. & Wilkinson, P., 2006. Determinants of winter indoor temperatures in low income households in England. *Energy and Buildings*, 38(3), pp.245–252.
- Orr, G., Lelyveld, T. & Burton, S., 2009. *Final Report: In-situ monitoring of efficiencies of condensing boilers and use of secondary heating*, Cheltenham.
- Osz, K., 2014. Understanding Heating Practices : The Example of TRV Use. In *BEHAVE2014 – Behavior and Energy Efficiency Conference*. Oxford.
- Oughton, D.R., Hodkinson, S. & Brailsford, R.M., 2008. Boilers and firing equipment. In *Faber & Kells Heating & Air-Conditioning of Buildings*. Taylor and Francis.
- Owen, A., Mitchell, G. & Gouldson, A., 2014. Unseen influence—The role of low carbon retrofit advisers and installers in the adoption and use of domestic energy technology. *Energy Policy*, 73, pp.169–179.
- Paauw, J., Roossien, B., Aries, M.B.C. & Guerra-Santin, O., 2009. “Energy pattern generator”: understanding the effect of user behaviour on energy systems. In *First European Conference on Energy Efficiency and Behaviour*. Maastricht, pp. 1–12.
- Palmer, J. & Cooper, I., 2013. *Housing energy fact file*, London.
- Palmer, J., Terry, N. & Pope, P., 2012. *How much energy could be saved by making small changes to everyday household behaviours?*, London.
- Papadopoulos, a. M. & Giama, E., 2007. Environmental performance evaluation of thermal insulation materials and its impact on the building. *Building and Environment*, 42(5), pp.2178–2187.
- Papadopoulos, A.M., 2005. State of the art in thermal insulation materials and aims for future developments. *Energy and Buildings*, 37(1), pp.77–86.
- Pargana, N.G.S.C., 2012. *Environmental impacts of the life cycle of thermal insulation materials of buildings Nuno Gonçalo Sequeira Correia Pargana Dissertation submitted to obtain the degree of Master in Environmental Engineering*. Technico Lisboa.
- Parity, 2012. *Parity Masterplan sample report: Victorian Terrace*,
- Passive House Institute, 2013. Refurbishment with Passive House components. Available at: [http://passiv.de/en/02\\_informations/04\\_refurbishment/04\\_refurbishment.htm](http://passiv.de/en/02_informations/04_refurbishment/04_refurbishment.htm).
- Patterson, M.G., 1996. What is energy efficiency? Concepts, indicators and methodological issues. *Energy Policy*, 24(5), pp.377–390.
- Pedrasa, M.A. a., Spooner, E.D. & MacGill, I.F., 2011. A novel energy service model and optimal scheduling algorithm for residential distributed energy resources. *Electric Power Systems Research*, 81(12), pp.2155–2163.
- Pedrasa, M.A. a., Spooner, E.D. & MacGill, I.F., 2009. Improved Energy Services Provision through the Intelligent Control of Distributed Energy Resources. In *IEEE Bucharest Power Tech Conference*. Bucharest, pp. 1–8.
- Peeters, L., de Dear, R.J., Hensen, J. & D’Haeseleer, W., 2009. Thermal comfort in residential buildings: Comfort values and scales for building energy simulation. *Applied Energy*, 86(5), pp.772–780.
- Peffer, T., Pritoni, M., Meier, A., Aragon, C. & Perry, D., 2011. How people use thermostats in homes: A review. *Building and Environment*, 46(12), pp.2529–2541.
- Pelenur, M.J. & Cruickshank, H.J., 2012. Closing the Energy Efficiency Gap: A study linking demographics with barriers to adopting energy efficiency measures in the home. *Energy*, 47(1), pp.348–357.
- Penna, P., Prada, A., Cappelletti, F. & Gasparella, A., 2014. Multi-objectives optimization of



- Energy Efficiency Measures in existing buildings. *Energy and Buildings*, 95, pp.57–69.
- Pérez-Lombard, L., Ortiz, J. & Maestre, I.R., 2011. The map of energy flow in HVAC systems. *Applied Energy*, 88(12), pp.5020–5031.
- Pérez-Lombard, L., Ortiz, J., Maestre, I.R. & Coronel, J.F., 2012. Constructing HVAC energy efficiency indicators. *Energy and Buildings*, 47, pp.619–629.
- Pérez-Lombard, L., Ortiz, J. & Velázquez, D., 2012. Revisiting energy efficiency fundamentals. *Energy Efficiency*, 6(2), pp.239–254.
- Petersdorff, C., Boermans, T., Harnisch, J., Joosen, S. & Wouters, F., 2002. *The Contribution of Mineral Wool and other Thermal Insulation Materials to Energy Saving and Climate Protection in Europe*, Cologne.
- PHE, 2014. *Minimum home temperature thresholds for health in winter – A systematic literature review*,
- Phylipsen, G.J.M., 2010. *Energy Efficiency Indicators: Best practice and potential use in developing country policy making*, Utrecht.
- Pilkington, B., Roach, R. & Perkins, J., 2011. Relative benefits of technology and occupant behaviour in moving towards a more energy efficient, sustainable housing paradigm. *Energy Policy*, 39(9), pp.4962–4970.
- Power, A., 2008. Does demolition or refurbishment of old and inefficient homes help to increase our environmental, social and economic viability? *Energy Policy*, 36(12), pp.4487–4501.
- Van Raaij, W.F. & Verhallen, T.M.M., 1983. Patterns of residential energy behaviour. *Journal of Economic Psychology*, 4, pp.85–106.
- Ravetz, J., 2008. State of the stock—What do we know about existing buildings and their future prospects? *Energy Policy*, 36(12), pp.4462–4470.
- Reister, D.B. & Devine, W.D., 1981. Total costs of energy services. *Energy*, 6(4), pp.305–315.
- Rhoads, J., Pennell, N., Freer, K. & Pender, R., 2010. *Low Carbon Retrofit Toolkit A roadmap to success*,
- Richardson, I., 2010. *Integrated high-resolution modelling of domestic electricity demand and low voltage electricity distribution networks*. Loughborough University.
- Richardson, I., Thomson, M. & Infield, D., 2008. A high-resolution domestic building occupancy model for energy demand simulations. *Energy and Buildings*, 40(8), pp.1560–1566.
- Richardson, I., Thomson, M., Infield, D. & Clifford, C., 2010. Domestic electricity use: A high-resolution energy demand model. *Energy and Buildings*, 42(10), pp.1878–1887.
- Rijal, H.B., Tuohy, P., Humphreys, M. a., Nicol, J.F., Samuel, a. & Clarke, J., 2007. Using results from field surveys to predict the effect of open windows on thermal comfort and energy use in buildings. *Energy and Buildings*, 39(7), pp.823–836.
- Rodriguez, M. & Calderon, C., 2014. Modelling approaches for retrofitting energy systems in cities. *disP - The Planning Review*, 50(3), pp.76–89.
- Roelich, K., Knoeri, C., Steinberger, J.K., Varga, L., Blythe, P.T., Butler, D., Gupta, R., Harrison, G.P., Martin, C. & Purnell, P., 2015. Towards resource-efficient and service-oriented integrated infrastructure operation. *Technological Forecasting and Social Change*, 92, pp.40–52.
- Rosen, M.A., Dincer, I. & Kanoglu, M., 2008. Role of exergy in increasing efficiency and sustainability and reducing environmental impact. *Energy Policy*, 36(1), pp.128–137.
- Rubens, S. & Knowles, J., 2013. *What people want from their heating controls: a qualitative study. A report to the Department for Energy and Climate Change. New Experience. DECC*, London.
- Rudge, J., 2012. Coal fires, fresh air and the hardy British: A historical view of domestic energy efficiency and thermal comfort in Britain. *Energy Policy*, 49, pp.6–11.
- Rye, C. & Scott, C., 2012. *The SPAB research report 1: U-value report*,
- Rysanek, a. M. & Choudhary, R., 2012. A decoupled whole-building simulation engine for rapid exhaustive search of low-carbon and low-energy building refurbishment options.

## References

- Building and Environment*, 50, pp.21–33.
- Rysanek, a. M. & Choudhary, R., 2013. Optimum building energy retrofits under technical and economic uncertainty. *Energy and Buildings*, 57, pp.324–337.
- dos Santos, A.H.C., Fagá, M.T.W. & dos Santos, E.M., 2013. The risks of an energy efficiency policy for buildings based solely on the consumption evaluation of final energy. *International Journal of Electrical Power & Energy Systems*, 44(1), pp.70–77.
- Sathaye, J., 2010. *Energy Efficiency Indicators Methodology Booklet*, Berkeley, CA.
- Schipper, L., Unander, F., Murtishaw, S. & Ting, M., 2001. Indicators of Energy Use and Carbon Emissions: Explaining the Energy Economy Link. , pp.49–81.
- Shippee, G.E., Commission, A.C. & State, A., 1996. The Future for Energy Service Companies : Changes and Trends. *The Electricity Journal*, 9(6), pp.80 – 84.
- Shipworth, M., Firth, S., Gentry, M.I., Wright, A.J., Shipworth, D.T. & Lomas, K.J., 2010. Central heating thermostat settings and timing: building demographics. *Building Research & Information*, 38(1), pp.50–69.
- Short, S., 2003. The United Kingdom 2000 Time Use Survey.
- Shove, E., 2010. Beyond the ABC: climate change policy and theories of social change. *Environment and Planning A*, 42(6), pp.1273–1285.
- Shove, E., 2003a. *Comfort, Cleanness and Convenience: The social organisation of normality*, Oxford: Berg Publishers.
- Shove, E., 2003b. Converging Conventions of Comfort, Cleanliness and Convenience. , (Spaargaren 1997).
- Shove, E., 1998. Gaps, barriers and conceptual chasms: theories of technology transfer and energy in buildings. *Energy Policy*, 26(15), pp.1105–1112.
- Shove, E. & Pantzar, M., 2005. Consumers, Producers and Practices: Understanding the invention and reinvention of Nordic walking. *Journal of Consumer Culture*, 5(1), pp.43–64.
- Shrubsole, C., Das, P., Milner, J., Hamilton, I.G., Spadaro, J.V., Oikonomou, E., Davies, M. & Wilkinson, P., 2015. A tale of two cities: Comparison of impacts on CO2 emissions, the indoor environment and health of home energy efficiency strategies in London and Milton Keynes. *Atmospheric Environment*, 120, pp.100–108.
- Silva, A.S. & Ghisi, E., 2014. Uncertainty analysis of user behaviour and physical parameters in residential building performance simulation. *Energy and Buildings*, 76, pp.381–391.
- Sorensen, B., 2004. *Renewable Energy: Its physics, engineering, use, environmental impacts, economy and planning aspects* 3rd ed., Amsterdam; Boston: Elsevier Academic Press.
- Sorrell, S., 2010. Energy, Economic Growth and Environmental Sustainability: Five Propositions. *Sustainability*, 2(6), pp.1784–1809.
- Sorrell, S., 2009. Jevons' Paradox revisited: The evidence for backfire from improved energy efficiency. *Energy Policy*, 37(4), pp.1456–1469.
- Sorrell, S., 2007. The economics of energy service contracts. *Energy Policy*, 35(1), pp.507–521.
- Sorrell, S., Mallet, A. & Nye, S., 2011. *Barriers to industrial energy efficiency: a literature review*, Vienna.
- Sovacool, B.K., 2011. Conceptualizing urban household energy use: Climbing the “Energy Services Ladder.” *Energy Policy*, 39(3), pp.1659–1668.
- Spataru, C., Gillott, M. & Hall, M.R., 2010. Domestic energy and occupancy: a novel post-occupancy evaluation study. *International Journal of Low-Carbon Technologies*, 5(3), pp.148–157.
- Stafford, A., Gorse, C. & Shao, L., 2011. *The Retrofit Challenge : Delivering Low Carbon Buildings*, Leeds.
- Stemmers, K. & Yun, G.Y., 2009. Household energy consumption: a study of the role of occupants. *Building Research & Information*, 37(5-6), pp.625–637.
- Steg, L., 2008. Promoting household energy conservation. *Energy Policy*, 36(12), pp.4449–4453.

- Steinberger, J.K., van Niel, J. & Bourg, D., 2009. Profiting from negawatts: Reducing absolute consumption and emissions through a performance-based energy economy. *Energy Policy*, 37(1), pp.361–370.
- Steinberger, J.K. & Roberts, J.T., 2010. From constraint to sufficiency: The decoupling of energy and carbon from human needs, 1975–2005. *Ecological Economics*, 70(2), pp.425–433.
- Stevens, G. & Bradford, J., 2013. Do U-value insulation? England's field trial of solid wall insulation. In *ECEEE Summer Study proceedings 2013*. pp. 1269–1280.
- Striebig, B., Ogundipe, A. & Papadakis, M., 2015. *Engineering Applications in Sustainable Design and Development*, CL Engineering.
- Summerfield, A.J., Lowe, R.J., Bruhns, H.R., Caeiro, J.A., Steadman, J.P. & Oreszczyń, T., 2007. Milton Keynes Energy Park revisited: Changes in internal temperatures and energy usage. *Energy and Buildings*, 39(7), pp.783–791.
- Szokolay, S.V., 2007. *Introduction to Architectural Science: The basis of sustainable design*, Oxford: Architectural Press.
- Toftum, J., Andersen, R.V. & Jensen, K.L., 2009. Occupant performance and building energy consumption with different philosophies of determining acceptable thermal conditions. *Building and Environment*, 44(10), pp.2009–2016.
- TRNSYS, 2013. TRNSYS: Transient System Simulation Tool (Homepage). Available at: <http://www.trnsys.com/> [Accessed August 15, 2013].
- Tuominen, P., Klobut, K., Tolman, A., Adjei, A. & de Best-Waldhofer, M., 2012. Energy savings potential in buildings and overcoming market barriers in member states of the European Union. *Energy and Buildings*, 51, pp.48–55.
- UK GBC, 2015. Over 200 businesses urge Chancellor to reconsider scrapping zero carbon (Press Release). *UK Green Building Council*.
- UK Government, 2008. *Climate Change Act 2008*, London: HMSO.
- UK Government, 2014. Planning Portal: Solid Wall Insulation. Available at: <http://www.planningportal.gov.uk/planning/greenerhomes/energysaving/solidwallinsulation> [Accessed December 9, 2015].
- US Department of Energy, 2013. Building Energy Software Tools Directory. *Energy Efficiency and Renewable Energy Building Technologies Office*. Available at: [http://apps1.eere.energy.gov/buildings/tools\\_directory/](http://apps1.eere.energy.gov/buildings/tools_directory/) [Accessed August 14, 2013].
- US Department of Energy, 2012. *Life-Cycle Assessment of Energy and Environmental Impacts of LED Lighting Products*. Prepared by: Navigant Consulting, Inc.
- Vaughan, A., 2016. UK solar power installations plummet after government cuts. *The Guardian*.
- Vine, E., 2005. An international survey of the energy service company (ESCO) industry. *Energy Policy*, 33(5), pp.691–704.
- Vlasova, L. & Gram-Hanssen, K., 2014. Incorporating inhabitants' everyday practices into domestic retrofits. *Building Research & Information*, 42(4), pp.512–524.
- Wang, S., Yan, C. & Xiao, F., 2012. Quantitative energy performance assessment methods for existing buildings. *Energy and Buildings*, 55, pp.873–888.
- Watson, M. & Shove, E., 2008. Product, Competence, Project and Practice: DIY and the dynamics of craft consumption. *Journal of Consumer Culture*, 8(1), pp.69–89.
- Weber, L., 1997. Some reflections on barriers to the efficient use of energy. *Energy Policy*, 25(10), pp.833–835.
- Wei, S., Jones, R. & de Wilde, P., 2014. Driving factors for occupant-controlled space heating in residential buildings. *Energy and Buildings*, 70, pp.36–44.
- Whitmarsh, L., O'Neill, S. & Lorenzoni, I., 2011. Climate change or social change? Debate within, amongst, and beyond disciplines. *Environment and Planning A*, 43(2), pp.258–261.
- Widén, J., Lundh, M., Vassileva, I., Dahlquist, E., Ellegård, K. & Wäckelgård, E., 2009. Constructing load profiles for household electricity and hot water from time-use data—

## References

- Modelling approach and validation. *Energy and Buildings*, 41(7), pp.753–768.
- Widén, J. & Wäckelgård, E., 2010. A high-resolution stochastic model of domestic activity patterns and electricity demand. *Applied Energy*, 87(6), pp.1880–1892.
- de Wilde, P., 2014. The gap between predicted and measured energy performance of buildings: A framework for investigation. *Automation in Construction*, 41, pp.40–49.
- Wilson, C. & Chatterton, T., 2011. Multiple models to inform climate change policy: a pragmatic response to the “beyond the ABC” debate. *Environment and Planning A*, 43(12), pp.2781–2787.
- Wilson, C., Crane, L. & Chryssochoidis, G., 2015. Why do homeowners renovate energy efficiently? Contrasting perspectives and implications for policy. *Energy Research & Social Science*, 7, pp.12–22.
- Wirl, F., 1995. Impact of Regulation on Demand Side Conservation Programs. *Journal of Regulatory Economics*, 52, pp.43–62.
- Wyatt, P., 2013. A dwelling-level investigation into the physical and socio-economic drivers of domestic energy consumption in England. *Energy Policy*, 60, pp.540–549.
- Xiaowu, W. & Ben, H., 2005. Exergy analysis of domestic-scale solar water heaters. *Renewable and Sustainable Energy Reviews*, 9(6), pp.638–645.
- Yang, L., Yan, H. & Lam, J.C., 2014. Thermal comfort and building energy consumption implications – A review. *Applied Energy*, 115, pp.164–173.
- Yang, S., Shipworth, M. & Huebner, G.M., 2015. His, hers or both's? The role of male and female's attitudes in explaining their home energy use behaviours. *Energy and Buildings*, 96, pp.140–148.
- Yao, R. & Steemers, K., 2005. A method of formulating energy load profile for domestic buildings in the UK. *Energy and Buildings*, 37, pp.663–671.
- Yohanis, Y.G. & Mondo1, J.D., 2010. Annual variations of temperature in a sample of UK dwellings. *Applied Energy*, 87(2), pp.681–690.
- Zero Carbon Hub, 2010. *Carbon compliance for tomorrow's new homes: A review of the modelling tool and assumptions. Topic 4: Closing the gap between designed and built performance*, London.
- Zhang, T., Siebers, P.-O. & Aickelin, U., 2012. A three-dimensional model of residential energy consumer archetypes for local energy policy design in the UK. *Energy Policy*, 47, pp.102–110.
- Zhao, H. & Magoulès, F., 2012. A review on the prediction of building energy consumption. *Renewable and Sustainable Energy Reviews*, 16(6), pp.3586–3592.

# Appendix

## Appendix A Embodied energy calculations for Chapter 4

### A.2 Derivation of values for embodied energy and carbon

*Table. A-1 Values for calculation of embodied energy and carbon in condensing boiler compared to CHP engine*

	Embodied energy	Embodied Carbon
<b>Materials of construction, total</b>	6853.5 MJ	409.5 kgCO <sub>2</sub>
<b>Boiler fraction of total</b>	5277 MJ = 1.47 MWh	282.6 kgCO <sub>2</sub>

*Table. A-2 Values for calculation of embodied energy and carbon in condensing boiler compared approximated to equivalent mass of stainless steel*

	Embodied energy	Embodied Carbon
<b>Stainless steel</b> <sup>6</sup>	56.70 MJ/kg	6.15 kgCO <sub>2</sub> e/kg
<b>40kg Stainless steel boiler</b>	2268 MJ = 0.63 MWh	246.0 kgCO <sub>2</sub>

*Table. A-3 Values for calculation of embodied energy and carbon in electric resistance heater compared to equivalent mass of steel (95 %) and nickel (5 %)*

	Embodied energy	Embodied Carbon
<b>Steel (UK (EU) average recycled content)</b>	20.10 MJ/kg	1.46 kgCO <sub>2</sub> e/kg
<b>Nickel</b>	165 MJ/kg	12.40 kgCO <sub>2</sub> e/kg
<b>Electric resistance heater total</b>	68 MJ = 19 kWh	2.01 kgCO <sub>2</sub> e
<b>Total for 6 heaters in the house</b>	114 kWh	12.0 kgCO <sub>2</sub> e

<sup>6</sup> From ICE database (Hammond & Jones 2011b)

Appendix A Embodied energy calculations for Chapter 4

**Table. A-4** Calculation of embodied energy of insulation delivering a thermal resistance,  $R_{ins}$  of  $1.33 (m^2K)/W$

Type of insulation	Density	Embodied...		Conductivity of insulation	Required insulation <sup>1</sup>		Embodied energy/carbon per m <sup>2</sup> wall		
	kg/m	Energy [MJ/kg]	Carbon [kgCO <sub>2</sub> e/kg]	W/(mK)	Thickness [m]	Mass [kg]	MJ	kWh	kgCO <sub>2</sub> e
<b>Mineral wool (MW)</b>	48	16.6	1.28	0.033	0.044	2.11	35.0	9.7	2.7
<b>Expanded polystyrene (ExPS)</b>	24	109.2	4.39	0.023	0.031	0.73	80.2	22.3	3.2

<sup>1</sup> Insulation for  $R_{ins} = 1.33 (m^2K)/W$  for 1 m<sup>2</sup> of wall

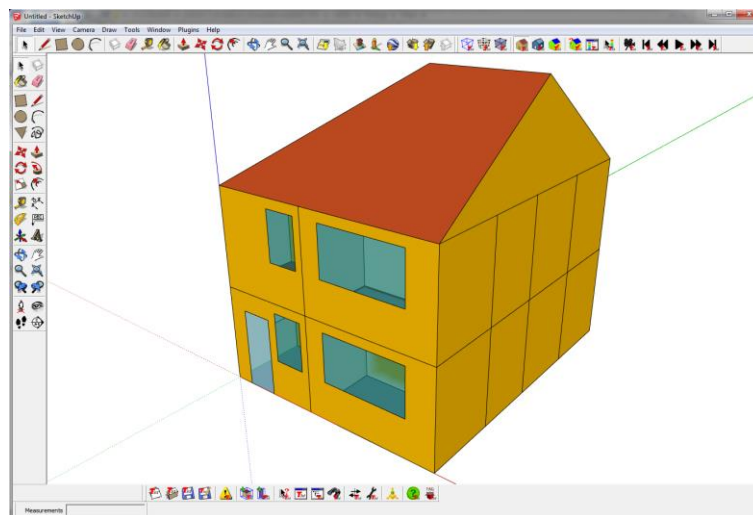
## Appendix B Building model development for Chapter 5

### B.1 Outline of modelling process

TRNSYS is made up of a suite of programs: the TRNSYS Simulation Studio, the simulation engine (TRNDll.dll), its executable (TRNExe.exe), and the building input data visual interface (TRNBuild.exe). In addition, a TRNSYS plug-in to GoogleSketchup® can be used to define building geometry (imported as a .idf file). A Matlab script has been developed for this project which runs the model simulation with varied input parameters, as well as generating and analysing results. The way by which these parts contribute to the modelling process is shown in Figure 5-1 and Table 5-1 in section 5.2. Each part is described in greater detail below.

#### B.1.1 *TRNSYS3D: Definition of building geometry*

The process begins by identifying the building geometry of the house to be modelled. The geometry is inputted using a TRNSYS plug-in to GoogleSketchup® called TRNSYS3D, ensuring that all adjacent walls are identified and matched. A screen shot of TRNSYS3D within GoogleSketchup® is shown in Figure. B-1.



*Figure. B-1* Screen shot TRNSYS3D within GoogleSketchup® for the definition of building geometry

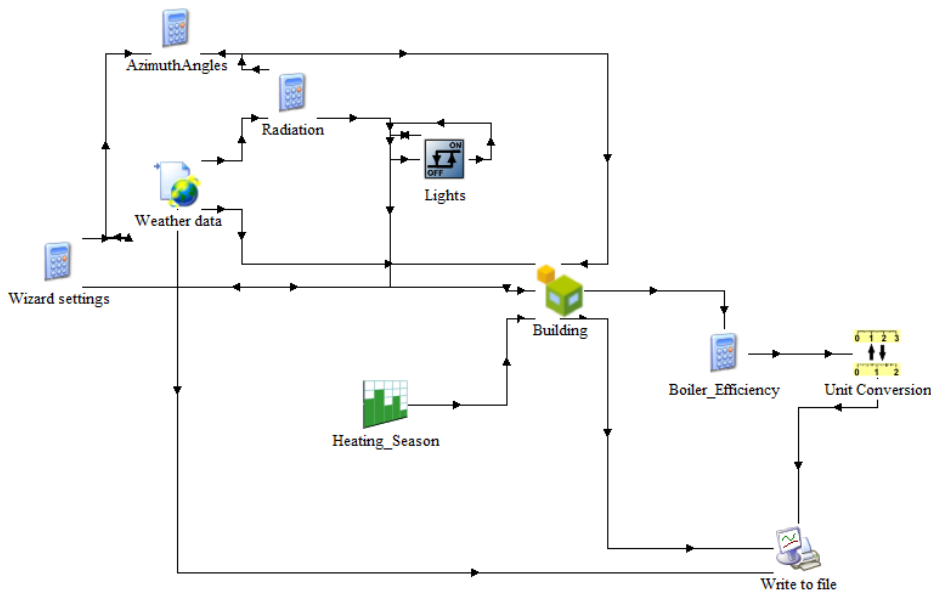
#### B.1.2 *TRNSYS Simulation Studio*

TRNSYS Simulation Studio is the main visual interface within which projects can be put together. Individual components are referred to as 'Type-\*\*', denoting their unique number reference. These can be connected together such that outputs of one are inputs to another.

Module 'types' used in the building model are given in Table. B-1. For a building simulation project, the house geometry created within TRNSYS3D is imported into TRNSYS using the Multi-zone Building Project Wizard within TRNSYS Simulation Studio. The multi-zone building is then specified within a specialised programme called TRNBuild. Details of the building are imported into the simulation studio as a building description file (\*.bui) which contains all the information required to simulate the building. Options such as simulation time length and time-step length are also specified in the TRNSYS Studio. A screen shot of the TRNSYS simulation studio is displayed in Figure. B-2.

*Table. B-1 Module 'Types' used in TRNSYS building model*

Type Name and Number	Description
<b>Type-15 Weather data reading and processing</b>	Reads in a standard format weather file and outputs weather parameters <sup>7</sup>
<b>Type-56 Multi-zone Building</b>	Performs simulation of building (further explanation below)
<b>Type-65 Online plotter</b>	Writes specified outputs to file and displays plots on screen
<b>Type-57 Unit Conversion routine</b>	Converts between units (in this model, from power in kJ/hr to kW)
<b>Equation</b>	Allows user defined equations to be inputted which aren't represented by another module



*Figure. B-2 Screen shot of TRNSYS Simulation Studio*

<sup>7</sup> Type-15 reads TMY2 (Typical Meteorological Year) data for a chosen location (other weather data files are also supported).



### B.1.3 TRNBuild: Multizone building

The main details of the building model are inputted within the building visual interface, TRNBuild, a screen shot of which is given in Figure. B-3. Specified within TRNBuild is all of the information required for the simulation of the thermal behaviour of the building. For each building zone, physical aspects of thermal simulation can be specified: construction of building envelope elements (walls, floor, ceiling and windows), infiltration, ventilation, heating, cooling, heat gains and comfort parameters. These are described in Table. B-2.

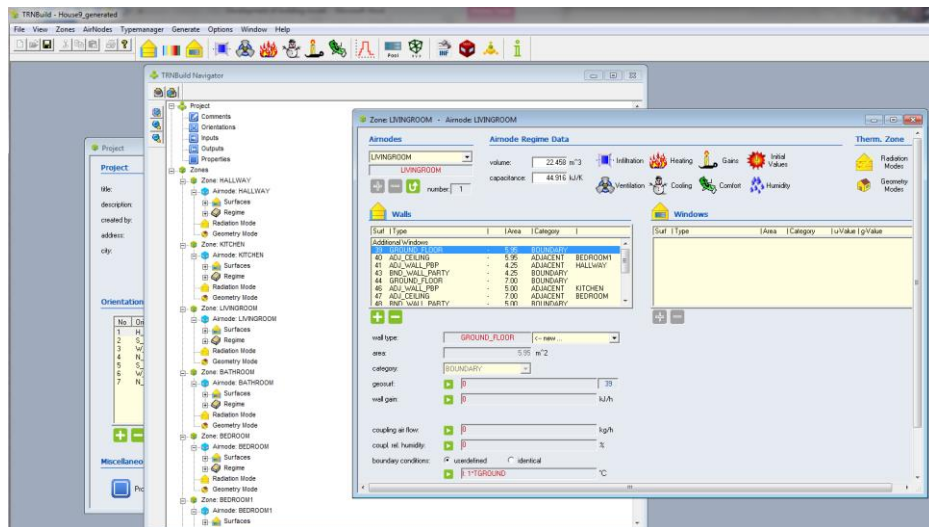


Figure. B-3 Screen shot of TRNBuild

*Table. B-2 Description of physical aspects of model*

<b>Physical aspect of thermal simulation</b>	<b>Description</b>	<b>Inputs</b>
<b><i>Building envelope construction</i></b>	Specification of building envelope construction elements as the combination of layers of materials	Thickness and properties of each layer within walls, ground, roof. Selection of window type
<b><i>Heating schedule</i></b>	Time and temperature of heating set-point throughout the day in each room	Time and temperature of heating set point
<b><i>Internal heat gains</i></b>	Specification of thermal gains within each room	Convective and radiative power of heat gain and absolute humidity of heat gain
<b><i>Ventilation and Infiltration rates</i></b>	Specification of ventilation (controlled) and infiltration (uncontrolled) air change within each room	Air change rate of infiltration and ventilation. for ventilation, temperature and humidity of incoming air can be specified
<b><i>Heating</i></b>	Definition of heating type in each room	Temperature set-point (described in heating schedule), heating power, proportion of heating power as convective or radiative, humidity of heating output
<b><i>Thermal capacitance of room</i></b>	Specification of thermal capacitance of air and furniture within room	Approximation of thermal capacitance based on expected content of room
<b><i>Temperature of adjoining external environment</i></b>	Specification of temperature of environment on the boundary of the rooms	For walls with boundary to the outside, external temperature is used, taken from weather file. For walls with internal boundaries, calculated temperatures are used. For walls with boundaries to an adjoining house, temperature may be user defined or set to be identical to the internal temperature of the zone.

In essence, the building model in TYPE-56 is an energy balance model, driven by the user inputted set-point temperature. The internal temperature that is reached by each rooms of the house is a combination of the set temperature given for the zone, the power of the radiator and the thermal resistance of the building envelope. The modelled temperature is governed by the modelling process; each time step the heat out of and into the zone is calculated which determines the change in internal energy of the zone and therefore the temperature of the zone at the next time step. The calculated temperature is compared to the set point temperature; if the room temperature is above the set point temperature, no heat input is called. If the temperature is below the set point, the heat required to raise the room temperature to the set-point level is calculated. If the required heat input is greater than the maximum heater output, the maximum will be inputted and the internal temperature will be below the set-point for that time step (as calculated by the energy balance).

TRNBuild writes all simulation details to a building description file (\*.b17), and this file is read by the simulation engine as the model is run.

#### ***B.1.4 Running of the simulation: TRNExe***

With all simulations details now specified, the model is run using the TRNSYS executable TRNExe. The TRNExe computes output results over each time step, displaying these results on the online plotter, as well as writing these results to output files where required.

#### ***B.1.5 Managing simulation variations: Matlab***

In order to allow for different configurations of EEM and occupants to be compared quickly using the model, a MATLAB script has been written which allows for the Building description file (\*.b17) and TRNSYS Input File (.dck) to be re-written with the alternative input parameters. These options are described in Table. B-3. The Matlab script allows multiple options to be specified and the simulation executed using a command line call-up. The script then performs some simple processing of the generated results file to calculate the total energy demand for heating for the simulation period which is written to a collated results file for later analysis.

*Table. B-3 Modelling parameters controlled through MATLAB script*

<b>Type of model Parameter</b>	<b>Model parameter</b>
<b><i>Simulation factors</i></b>	Simulation length (Start time / stop time) Time step Length of heating season House type Adjacent house temperature
<b><i>Occupancy factors</i></b>	Occupant type Internal temperatures Bedroom window infiltration Secondary heating power schedule
<b><i>Technology factors</i></b>	Insulation level for external wall and roof Thermal resistance of windows Heat control type Radiator power Airtightness of walls

## B.2 Model values for investigation of savings from individual technologies used in Chapter 5

*Table. B-4 Values of model parameters used in section 5.4.2 for the calculation of savings from individual technologies*

Variable	Energy efficiency measure being investigated				
	Boiler efficiency	Level of Insulation	Heating control	Service level	
				Temperature reduction	Partial under-heating
<b>Boiler efficiency</b>		70 %	70 %	70 %	70 %
<b>Thermal transmittance, <math>W/(m^2K)</math></b>					
<b>Wall</b>	1.44		1.44	1.44	1.44
<b>Roof</b>	1.00		1.00	1.00	1.00
<b>Window</b>	2.83		2.83	2.83	2.83
<b>Internal temperature set-point</b>	21 °C	21 °C	21 °C		21 °C
<b>Heating control type</b>	Programmable timer control	Programmable timer control		Programmable timer control	
<b>Occupancy type</b>	Working Family	Working Family	Working Family	Working Couple	Working Couple

## Appendix C Model validation for Chapter 5

The purpose of using a building model is to represent a real world situation within a computer simulation, and therefore model validation is required to confirm how close the model results are to reality. Validation can be undertaken using statistical data, to give a typical range of results across a broad sample, using empirical measured data to give a one-to-one comparison for the model to represent a specific situation, or by comparing results to the modelled results calculated in other studies.

A residential building is a complex system in which technical aspects such as structural engineering, thermodynamics and heat transfer interact with many human elements, not only how occupants use and live in their house, but also the competence with which the house was constructed and any upgrades are carried out. Consequently, even if the engineering calculations are complete, there will be limitations in how accurately the model can represent reality. The validation process is therefore less about attempting to calibrate a model with an aim to return results as close to measured values as possible, and more about understanding the limitations of the model and using this knowledge to appropriately inform conclusions.

### C.1 Statistical validation

Statistical benchmarking has been undertaken using the data set made available by the National Energy Efficiency Data-framework (NEED) produced by the UK Government's Department of Energy and Climate Change (DECC) (DECC 2014c). The dataset provides measures of gas and electricity use from 3.5 million UK homes for 2012; average figures comprise mean, median, upper and lower quartiles for gas and electricity consumption. Data is classified by regional location, house type, number of bedrooms and energy supply. With such a large data set available, analysis is required to identify the options which best represent the modelled house; the available options and process for choosing the most appropriate are presented in Table. C-1.

**Table. C-1** Categories of statistical data available in NEED database with indication of choice made for statistical benchmark.

<b>Category</b>	<b>Options</b>	<b>Choice for statistical benchmark</b>
<b>Region</b>	East Midlands, East of England, London, North East, North West, South East, South West, Wales, West Midlands, Yorkshire and The Humber	South East. Further analysis presented in section C.1.1
<b>Property type</b>	Detached, Semi-detached, End terrace, Mid terrace, Bungalow, Purpose built flat, Converted flat	Semi-detached house being modelled (floor area of 93 m <sup>2</sup> )
<b>Year of construction</b>	Pre 1919, 1919-44, 1945-64, 1965-82, 1983-92, 1993-99, Post 1999	Pre 1919 for pre-insulation, average of 1945-64, 1965-82 for post-insulation. Further analysis presented in section C.1.2
<b>Number of bedrooms</b>	1 bedroom, 2 bedrooms, 3 bedrooms, 4 bedrooms, 5 or more bedrooms	3 bedroom house being considered (floor area of 93 m <sup>2</sup> )
<b>Gas present</b>	Yes, No	Yes (gas heating being considered)
<b>Electricity type</b>	Standard, Economy7	Standard (Economy7 is typical of electric heating)

Further to the identification of statistical data for gas usage, values must be made comparable to heat energy demand values generated by the building model, as covered in section C.1.3.

### **C.1.1**      *Selection of region*

The decision of which dataset to select is made based on the best matching of the local weather to the weather used within the model; heating degree days (HDD) is to be used as the weather indicator for comparison. In this work, the model takes weather data from the Meteonorm weather file for London which represents a Typical Meteorological Year (TMY2). NEED is based on data from 2012, across ten regions of the UK. For a statistical benchmark, the NEED data for the region with the closest weather match is selected.

In order to identify which region to take data from for the statistical benchmark, weather data for the year 2012 has been attained from a publically available dataset<sup>8</sup> for location in

---

<sup>8</sup> Degree day data has been taken from Stark Software International at <http://www.degree-days-for-free.co.uk/>

the South East of England. For calculation of Heating Degree-days (HDD), a base temperature of 15.5 °C is used. The total HDDs for each location are compared to the total HDDs in the Meteonorm weather data file. Of the 19 locations considered, the eight locations with the best match ( $\pm 100$  HDDs) are given in Table. C-2. These eight locations are within three regions of the NEED data-set and

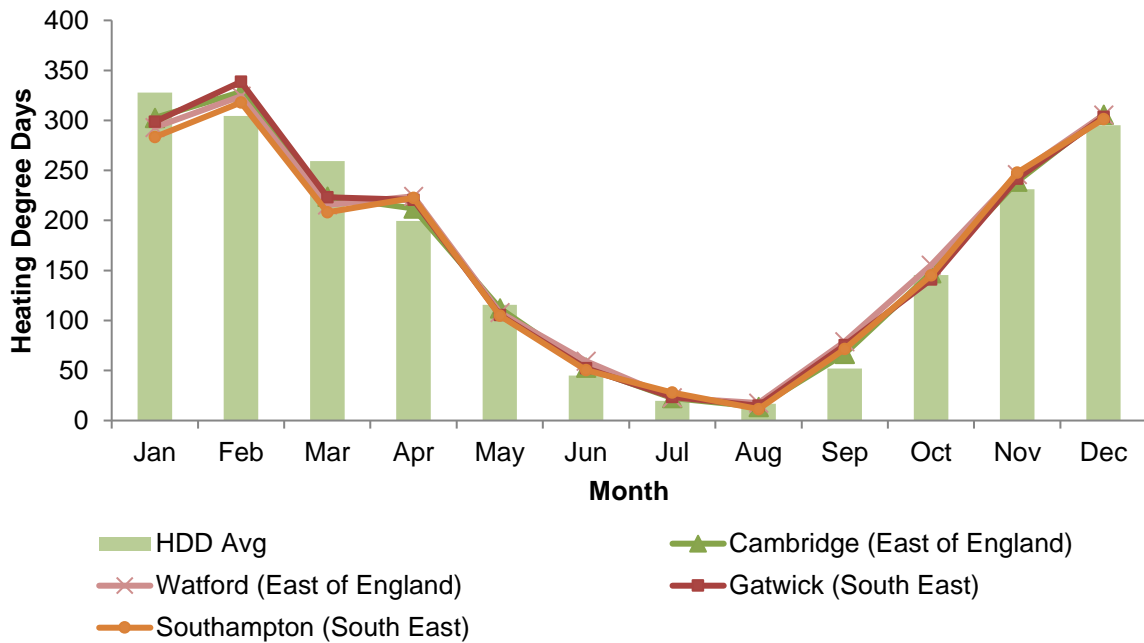
Table. C-3 presents the average total heating degree days and standard deviations for these regions. The monthly HDDs for the four locations with the best match ( $\pm 50$  HDDs) are shown in Figure. C-1. For individual locations, Cambridge (East of England) has the closest value and also shows closest agreement with the Meteonorm data by monthly totals. South East England has the closest agreement by NEED region. London is next closest, but has a large standard deviation due to the large difference between Croydon (1903.8 HDDs) and Enfield (2097.6 HDDs).

*Table. C-2 Total Heating Degree Days (HDDs) for year 2012*

Weather location	NEED region	Total HDDs
<b>Meteonorm (dataset for London, UK)</b>		2012.5
<b>Croydon</b>	London	1903.8
<b>Gatwick</b>	South East	2038.3
<b>Cambridge</b>	East of England	2027.3
<b>Enfield</b>	London	2097.6
<b>Guilford</b>	South East	2093.8
<b>Southampton</b>	South East	1991.8
<b>Slough</b>	South East	1914.0
<b>Watford</b>	East of England	2050.5

*Table. C-3 Average total HDDs and standard deviation for regions within NEED dataset (DECC, 2014d)*

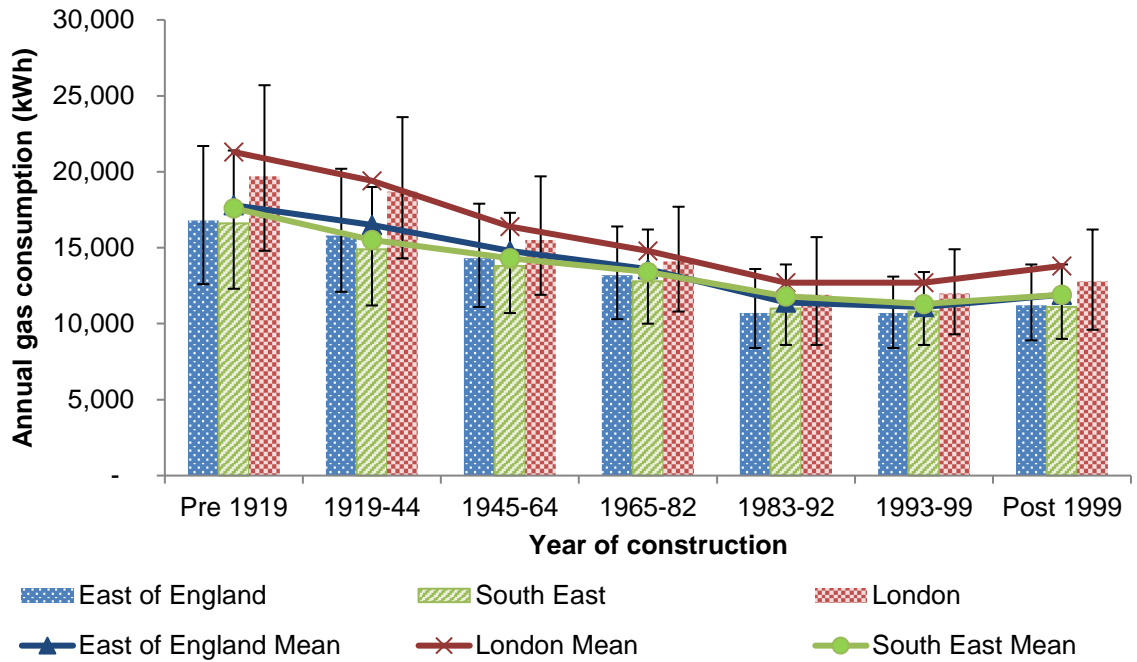
NEED region	Average HDDs	Standard deviation
<b>Meteonorm (dataset for London, UK)</b>	2012.5	
<b>East of England</b>	2038.9	16.4
<b>London</b>	2000.7	137.0
<b>South east</b>	2009.5	76.1



**Figure. C-1** Comparison of total monthly HDDs (year 2012) for four locations against HDDs in Meteororm data set

Gas consumption data from the NEED data base for 3 bedroom houses with gas supply and with standard electricity tariff (suggesting gas fuelled heating) are shown in Figure. C-2 for regions of East of England, South East and London across all years of construction. The aim of this comparison is to assess how closely matched the different data sets are. The figure shows that the data for East of England and South East are similar for both mean and median gas consumption, whereas consumption figures for London are higher across all data. As the house being considered is more general to the rest of the UK, it is most appropriate to use data from South East England.





**Figure. C-2** Statistical values for annual gas consumption from NEED data-set for regions of East of England, South East and London. Coloured bars represent median values and error bars represent upper and lower quartile

### C.1.2 Selection of year of construction

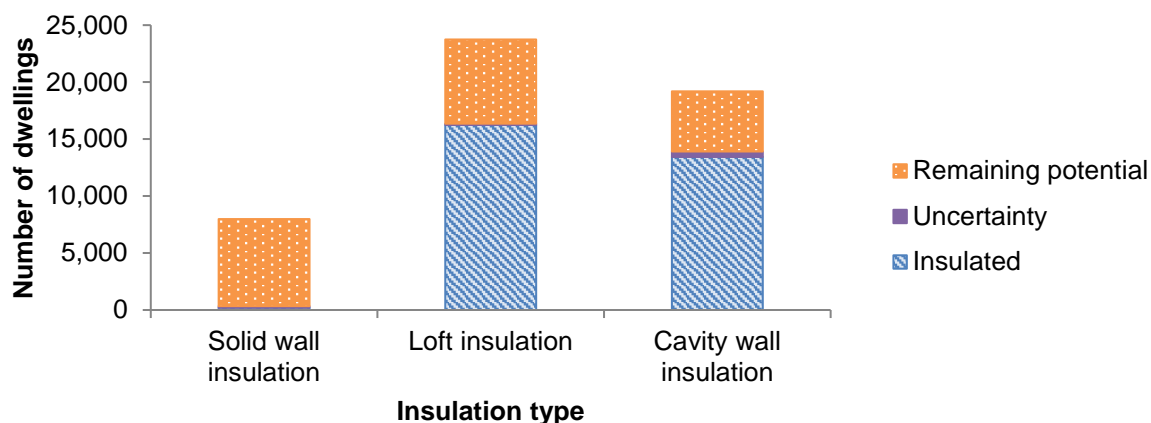
The next decision is which year of data to use, which will depend on what type of house is being considered.

In this project, solid wall houses are being considered as these are typically defined as 'hard to treat' properties. Figure. C-3 shows the construction of UK houses by material and shows that for the period 1919-1944, solid masonry represented approximately half of construction, and pre 1919 the majority of construction was solid masonry.



**Figure. C-3** House wall types by year of construction for UK houses taken from (DCLG, 2010)

Figure. C-4 shows the proportion of dwellings insulated, by insulation type. The figure reveals that only 3 % of solid walls are insulated compared to 70 % of cavity walls and 68 % of lofts. In 1985, building regulations required external wall U-values of 0.6 W/(m<sup>2</sup>K) as a maximum, resulting in cavity wall insulation being installed as standard after this time. The effect of this change in building standards can be seen in Figure. C-2 whereby the data for homes built since 1983 all show similar annual energy consumption and the majority can be assumed to have been built with cavity wall insulation.



*Figure. C-4* Number of properties with solid, cavity wall and loft insulation out of broad sample of UK homes (Taken from (DCLG, 2010))

The houses in the middle of these two bands, 1945-1982 can be assumed to have a majority of cavity wall construction, 70 % of which have had cavity wall insulation retrofitted in. These represent a post insulation house type and have been combined in Table. C-4 to give a post-insulation bench-mark, taking average values for the mean and median, and highest and lowest values for the upper and lower quartile respectively.

*Table. C-4* Derivation of statistical benchmark for post-insulated dwelling (data from (DECC, 2014d))

Year of construction	Annual gas consumption (kWh)			
	Mean	Upper quartile	Median	Lower quartile
<b>1945-64</b>	14,300	17,300	13,800	10,700
<b>1965-82</b>	13,400	16,200	12,800	10,000
<b>Combined</b>	13,850	17,300	13,300	10,000

It is recognised that the values for energy consumption in **Table. C-4** are representative of cavity wall insulation whereas the un-insulated values are for solid wall, however, these benchmark values are acceptable for showing the range of values between upper and lower quartiles.

### C.1.3 Conversion of heat demand to gas consumption

The final consideration is how to accurately convert gas consumption of the NEED data benchmarks to heating demand calculated in the model. This conversion either requires modelling other end uses which also consume gas, or making an informed assumption of the proportion of gas consumption due to heating. The modelling of hot water and cooking systems, including the factors which determine their demand, is outside the scope of this work and therefore the latter option will be selected.

DECC publish national statistical data on energy use, including domestic energy consumption by end use (DECC 2014a; DECC 2014b). Table C-5 shows the data for gas use by energy end use for the UK and reveals that space heating accounts for 68 % of total gas use.

*Table. C-5 Total UK domestic gas consumption by end-use. Taken from Table 3.02 in (DECC, 2014a)*

End use	Total domestic	Space	Water	Cooking	Lights and appliances <sup>3</sup>
<b>Gas consumption (TWh)</b>	450.9	305.2	82.4	11.7	51.7
<b>Percentage of total</b>		68 %	18 %	3 %	11 %

The breakdown by end use is achieved through modelling using the Cambridge Housing Model v2.5 developed by Cambridge Architectural Research Ltd which is closely linked to SAP 2009 and represents housing across the UK.

Table C-6 displays the final values of the benchmark for domestic heating consumption.

*Table. C-6 Benchmark values determined for gas consumption for space heating*

Year of construction	Annual gas consumption (kWh)			
	Mean	Upper quartile	Median	Lower quartile
<b>Un-insulated (pre 1919)</b>	12,108.8	14,723.2	11,420.8	8,462.4
<b>Insulated (1945-82)</b>	9,528.8	11,902.4	9,150.4	6,880.0

## C.2 Sensitivity Analysis

*Table. C-7 Results of sensitivity analysis for Working Family Occupancy Pattern*

Model Parameter (DPC)		Initial set value for input ( $k_j$ ) and output ( $y_i$ ) parameter		Incremental change in input parameter, $\Delta k_j$		Overall Change in output variable, $\Delta y_i$		Sensitivity coefficient, $\partial y_i / \partial k_j$		Normalised Sensitivity coefficient, $S_{ij}$		Linearity <sup>1</sup>
		$k_j$	$y_i$	1 %	5 %	1 %	5 %	1 %	5 %	1 %	5 %	
House Temperature	°C	21.0	17451.3	0.2 [20.8-21.2]	1.0 [20-22]	372.1	1862.4	930.2	931.2	1.12	1.12	L
Night time Temperature	°C	17.0	17451.3	0.2 [16.8-20.8]	1.0 [16.1-17.9]	349.4	1725.3	873.6	862.7	0.85	0.84	L
Ground Temperature	°C	10.0	17451.3	0.1 [9.9-10.1]	0.5 [9.5-10.5]	-43.9	-219.4	-219.5	-219.4	-0.13	-0.13	L
Next door temperature	°C	19.0	17451.3	0.2 [18.8-19.2]	1.0 [18.0-20.0]	-89.0	-444.8	-222.5	-222.4	-0.24	-0.24	L
Boiler efficiency (BI <sup>2</sup> )	-	0.700	17451.3	0.007 [0.69-0.71]	0.035 [0.665-0.735]	-349.1	-1749.5	-24932.9	-24992.9	-1.00	-1.01	L
Boiler efficiency (AI <sup>2</sup> )	-	0.880	13881.7	0.010 [0.870 – 0.890]	0.044 [0.836-0.924]							
Radiator power	kW	2.00	17451.3	0.02 [1.98-2.02]	0.10 [1.90-2.10]	0.0	0.0	0.0	0.1	0.00	0.00	L
Length of Heating season	days	211	17451.3	2 [209-213]	10 [201-221]	190.5	864.3	47.7	43.2	0.58	0.53	N
Wall U-value (BI)	W/(m <sup>2</sup> K)	1.400	17451.3	0.014 [1.386-1.414]	0.070 [1.330-1.470]	87.6	437.0	4378.0	3121.5	0.35	0.25	N
Wall U-value (AI)	W/(m <sup>2</sup> K)	0.440	14131.7	0.01 [0.43-0.45]	0.03 [0.41-0.47]	69.2	223.6	2472.2	1597.0	0.08	0.05	N
Roof U-value (BI)	W/(m <sup>2</sup> K)	0.99	17451.3	0.01 [0.98-1.01]	0.05 [0.95-1.05]		195.0	0.0	1949.5	0.00	0.11	
Roof U-value (AI)	W/(m <sup>2</sup> K)	0.160	15508.9	0.002 [0.158-0.162]	0.008 [0.152-0.168]	9.7	41.9	2432.5	2619.4	0.03	0.03	N
Floor U-value	W/(m <sup>2</sup> K)	0.816	17451.3	0.008 [0.808-0.824]	0.040 [0.776-0.856]	42.2	200.2	2634.4	2503.0	0.13	0.12	N
Infiltration rate	ach	0.750	17451.3	0.008 [0.742-0.758]	0.038 [0.713-0.788]	63.9	299.5	3993.1	3940.4	0.17	0.17	L

<sup>1</sup>Linearity refers to whether model has a linear (L) or non-linear (N) relationship to input variable; <sup>2</sup> BI: Before Intervention, AI: After Intervention

**Table. C-8** Results of sensitivity analysis for Daytime-Present Couple Occupancy Pattern

Model Parameter (DPC)		Initial set value for input ( $k_j$ ) and output ( $y_i$ ) parameter		Incremental change in input parameter, $\Delta k_j$		Overall Change in output variable, $\Delta y_i$		Sensitivity coefficient, $\partial y_i / \partial k_j$		Normalised Sensitivity coefficient, $S_{ij}$		Linearity <sup>1</sup>
		$k_j$	$y_i$	1 %	5 %	1 %	5 %	1 %	5 %	1 %	5 %	
House Temperature	°C	21.0	17451.3	0.2 [20.8-21.2]	1.0 [20-22]	618.1	3090.5	3090.3	3090.5	3.08	3.08	L
Night time Temperature	°C	17.0	17451.3	0.2 [16.8-20.8]	1.0 [16.1-17.9]	232.1	1148.3	1160.5	1148.3	0.94	0.93	L
Ground Temperature	°C	10.0	17451.3	0.1 [9.9-10.1]	0.5 [9.5-10.5]	-48.4	-242.1	-484.1	-484.1	-0.23	-0.23	L
Next door temperature	°C	19.0	17451.3	0.2 [18.8-19.2]	1.0 [18.0-20.0]	-98.7	-493.3	-493.4	-493.3	-0.44	-0.44	L
Boiler efficiency (BI <sup>2</sup> )	-	0.700	17451.3	0.007 [0.69-0.71]	0.035 [0.665-0.735]	-421.5	-2112.6	-60214.3	-60359.4	-2.00	-2.01	L
Boiler efficiency (AI <sup>2</sup> )	-	0.880	13881.7	0.010 [0.870 – 0.890]	0.044 [0.836-0.924]							
Radiator power	kW	2.00	17451.3	0.02 [1.98-2.02]	0.10 [1.90-2.10]	0.0	0.0	0.0	0.0	0.00	0.00	L
Length of Heating season	days	211	17451.3	2 [209-213]	10 [201-221]	242.1	1070.8	121.0	107.1	1.21	1.07	N
Wall U-value (BI)	W/(m <sup>2</sup> K)	1.400	17451.3	0.014 [1.386-1.414]	0.070 [1.330-1.470]	111.2	554.8	11122.0	7925.6	0.74	0.53	N
Wall U-value (AI)	W/(m <sup>2</sup> K)	0.440	14131.7	0.01 [0.43-0.45]	0.03 [0.41-0.47]	86.2	278.3	6154.3	3975.7	0.16	0.10	N
Roof U-value (BI)	W/(m <sup>2</sup> K)	0.99	17451.3	0.01 [0.98-1.01]	0.05 [0.95-1.05]		238.4		4768.4	0.00	0.22	
Roof U-value (AI)	W/(m <sup>2</sup> K)	0.160	15508.9	0.002 [0.158-0.162]	0.008 [0.152-0.168]	11.8	50.8	5895.0	6351.3	0.05	0.05	N
Floor U-value	W/(m <sup>2</sup> K)	0.816	17451.3	0.008 [0.808-0.824]	0.040 [0.776-0.856]	54.2	256.9	6776.2	6423.3	0.26	0.25	N
Infiltration rate	ach	0.750	17451.3	0.008 [0.742-0.758]	0.038 [0.713-0.788]	78.3	367.3	9793.7	9665.5	0.35	0.34	L

<sup>1</sup> Linearity refers to whether model has a linear (L) or non-linear (N) relationship to input variable; <sup>2</sup> BI: Before Intervention, AI: After Intervention

### C.3 Rebound Effect

*Table. C-9 Temperature set-points throughout house used in initial case and for a 1 °C comfort taking rebound effect*

Room or Zone	Set-point temperatures (°C )	
	Initial	1°C rebound
<b>Indicative internal temperature</b>	21	22
<b>House thermostat<sup>1</sup></b>	21	22
<b>Living room</b>	21	22
<b>Kitchen</b>	19	19
<b>Bedroom<sup>2</sup></b>	19	19
<b>Bathroom</b>	21	21
<b>Hall</b>	19	19
<b>Night time</b>	17	17
<b>Low temperature set-point when heating off</b>	12	12
<b>Low temperature set-point when room unoccupied</b>	15	16
<b>Low temperature set-point when house unoccupied</b>	14	15

<sup>1</sup> In initial heating scenarios of programmable timer, all rooms are set at this value of house thermostat

<sup>2</sup> This temperature is used for bedroom during waking hours in zonal heating scenarios, but drops to night time temperature during sleeping hours

## **Appendix D Building model development for Chapter 6**

### **D.1 Description of enhanced building energy model methodology**

#### *D.1.1 Description of TRNSYS model*

For improvement of the building energy model to be more representative of reality, the Type 56 building model as used in Chapter 5 is enhanced with the use of two new TRNSYS components. The Radiator unit (Type 320) allows the specification of water parameters and thermal inertia in the heating system. The heat output is connected to the building (Type 56) as a heat gain and thermal inertia maintains heat input beyond when the heating system is to turn heating off. The Thermostat Controller (5-stage room thermostat) (Type 108) compares the internal temperature and temperature set-point to give a signal to the radiator unit. The parameters used to model the radiators and thermostat controller are given in Table. D-1 and Table. D-2 respectively. A controller is used for the living room in all heating control modes and an additional controller is used in the bedroom for the timer and TRV and AZHC heating control options. The set-point temperature schedule is read from the Type 56 building unit for the living room or bedroom as appropriate. All other rooms have heating simulated through the heating function of the Type 56 building unit as in Chapter 5. The heating energy demand is calculated from an output of the radiator unit for the living room 1 and bedroom 1 (heat injected in radiator) and uses the value of heat demand calculated in the Type 56 building unit for the remaining rooms. The heating energy demand is converted to final energy demand in an equation unit (division by the boiler efficiency factor). A screen-shot of the TRNSYS model is shown in Figure. D-1.

Appendix D Building model development for Chapter 6

*Table. D-1 Values of parameters in radiator units TRNSYS building model*

Parameter	Unit	Value
Length of supply pipe 1	m	2
Length of exhaust pipe 2	m	2
Pipe diameter	m	0.025
Horizontal or vertical pipe	-	0 (horizontal)
Emissivity of outer surface	-	0.5
Specific heat of fluid	kJ/(kg.K)	4.19
Maximum mass flow rate	kg/hr	1768
Radiative fraction of total power at nominal conditions (dt=60)	-	0.2
Nominal power of radiator (dt=60)	W	Living room: 2000; Bedroom: 1500
Radiator exponent (convection + radiation)	-	1.3
Radiator thermal capacitance (metal + fluid)	kJ/K	150
Initial radiator temperature	°C	25
<b>Input</b>		
Supply temperature	°C	55
Inside room temperature (type 56: star node temperature)	°C	(from Type 56: star node temperature)
Mass flow rate control	-	(from Type 320 control)

*Table. D-2 Values of parameters in thermostat units in TRNSYS building model*

Parameter	Unit	Value
No of oscillations permitted	-	5
1st stage heating in 2nd stage?	-	1 (1 <sup>st</sup> stage heating remains on)
2nd stage heating in 3rd stage?	-	1 (2nd stage heating remains on)
1st stage heating in 3rd stage?	-	1 (1 <sup>st</sup> stage heating remains on)
1st stage cooling in 2nd stage?	-	1 (1 <sup>st</sup> stage cooling remains on)
Temperature dead band	°C	1
<b>Input</b>		
Monitoring temperature	°C	(from Type 56: living room temperature)
1st stage heating set-point	°C	20
2nd stage heating set-point	°C	9
3rd stage heating set-point	°C	7
1st stage cooling set-point	°C	24
2nd stage cooling set-point	°C	26



## D.1 Description of enhanced building energy model methodology

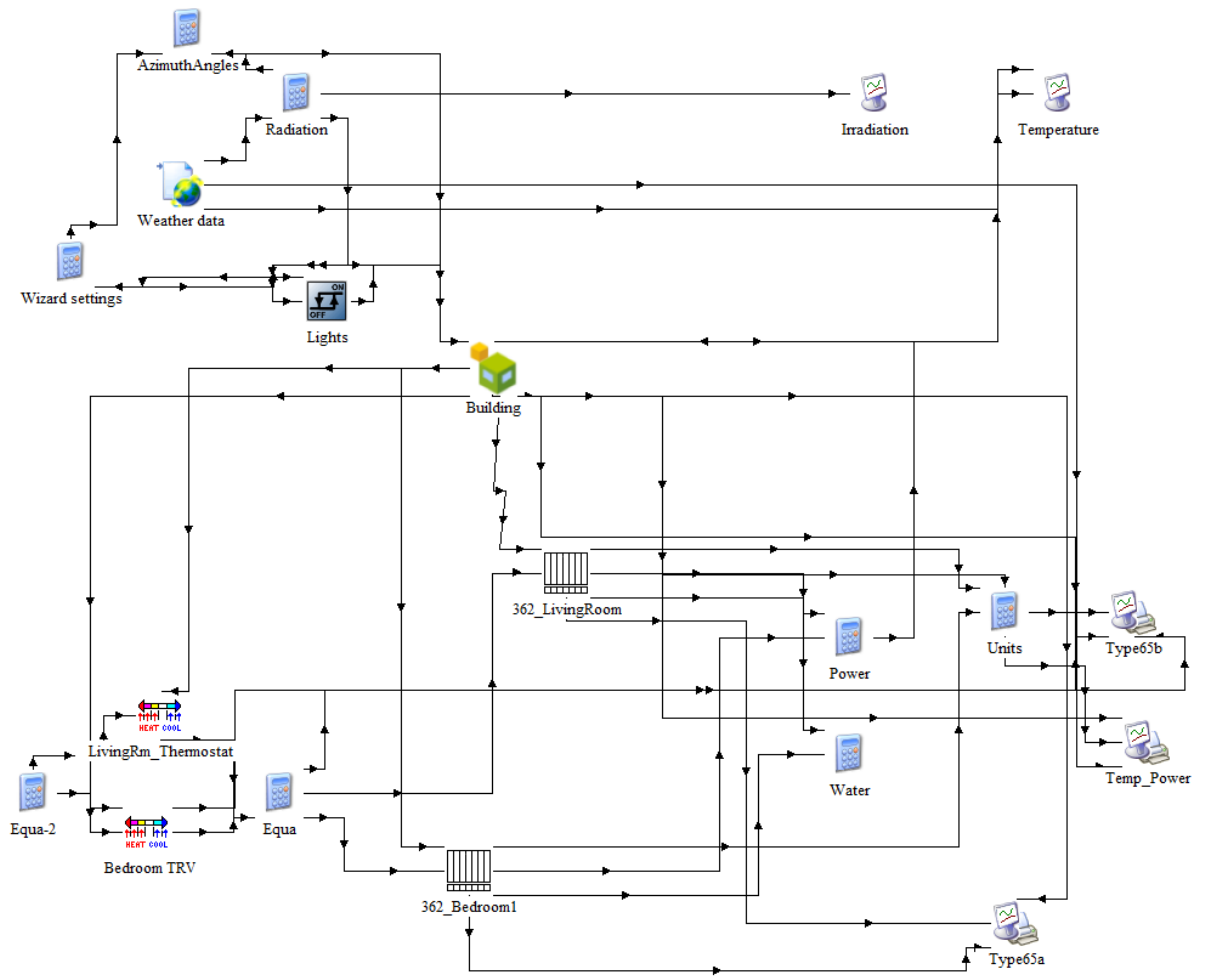


Figure D-1 Screen shot of the TRNSYS Simulation Studio

### D.1.2 Description of Matlab process to run model

Having developed the TRNSYS building model with enhanced capability to model the internal temperature in the living room and bedroom, Matlab is used to run the model for the multiple cases covering ten EEMs and three occupancy patterns. The building modelling methodology involves four steps. In step 1 and 2, dummy variables are replaced in the building description file and TRNSYS input file respectively so that these input files to the TRNSYS simulation contain the correct parameters for each simulation. Dummy variables are replaced in text files using a Matlab “REPLACEIFILE” command. In step 3 the simulation is run in TRNSYS and results files are generated. In step 4 results are analysed.

#### Step 1: Building description file (\*.b17)

The building description file (\*.b17) is built of three sub-files:

*File 1:* definition of temperatures in predefined schedules

*File 2:* selection of heating file and occupant type

*File 3:* definition of building envelope elements (external walls and roof)

Values of each parameter are defined in the Matlab script and dummy variables in each file are replaced with the required model syntax. The final building description file (\*.b17) is made by appending together the three sub-files within the Matlab script.

### **Step 2: TRNSYS input file (\*.dck)**

Parameters are replaced in the template file:

- Start, stop and step time of simulation
- Power and temperature set-point schedule of radiators
- Results file name

All parameters are defined in the Matlab script

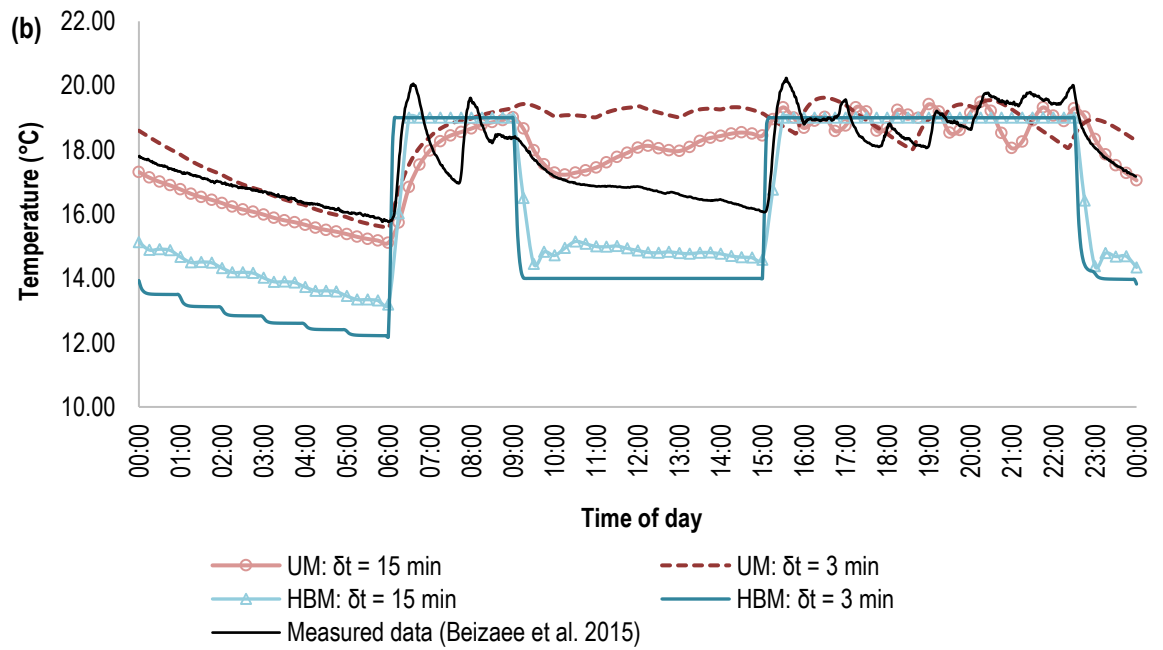
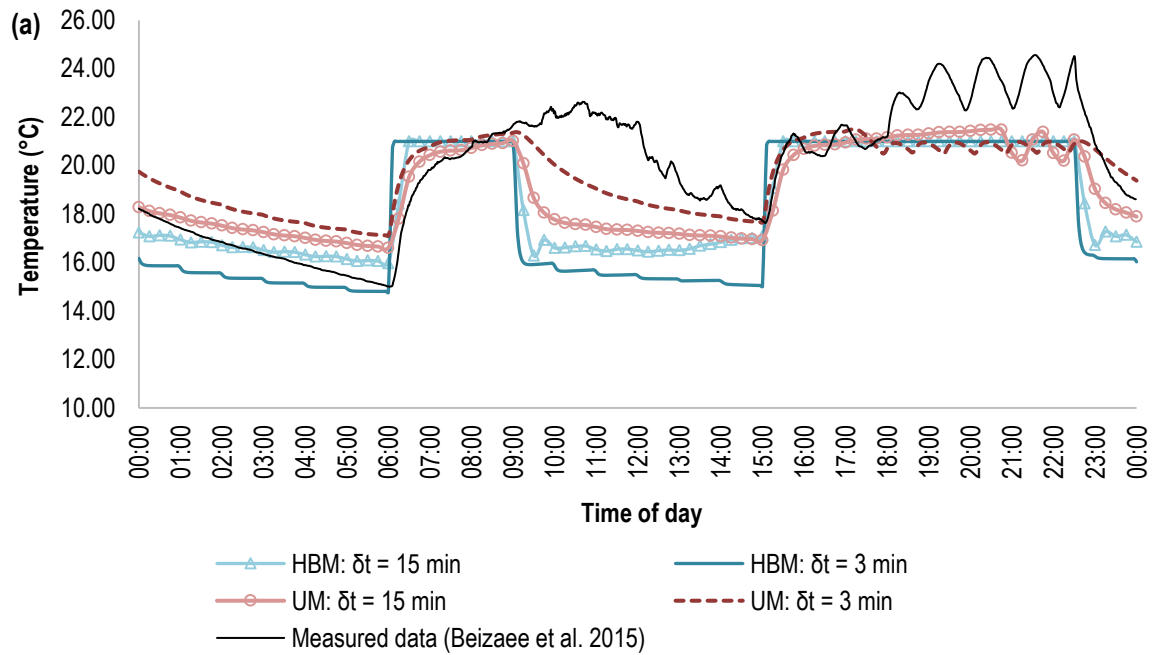
### **Step 3: Simulation run**

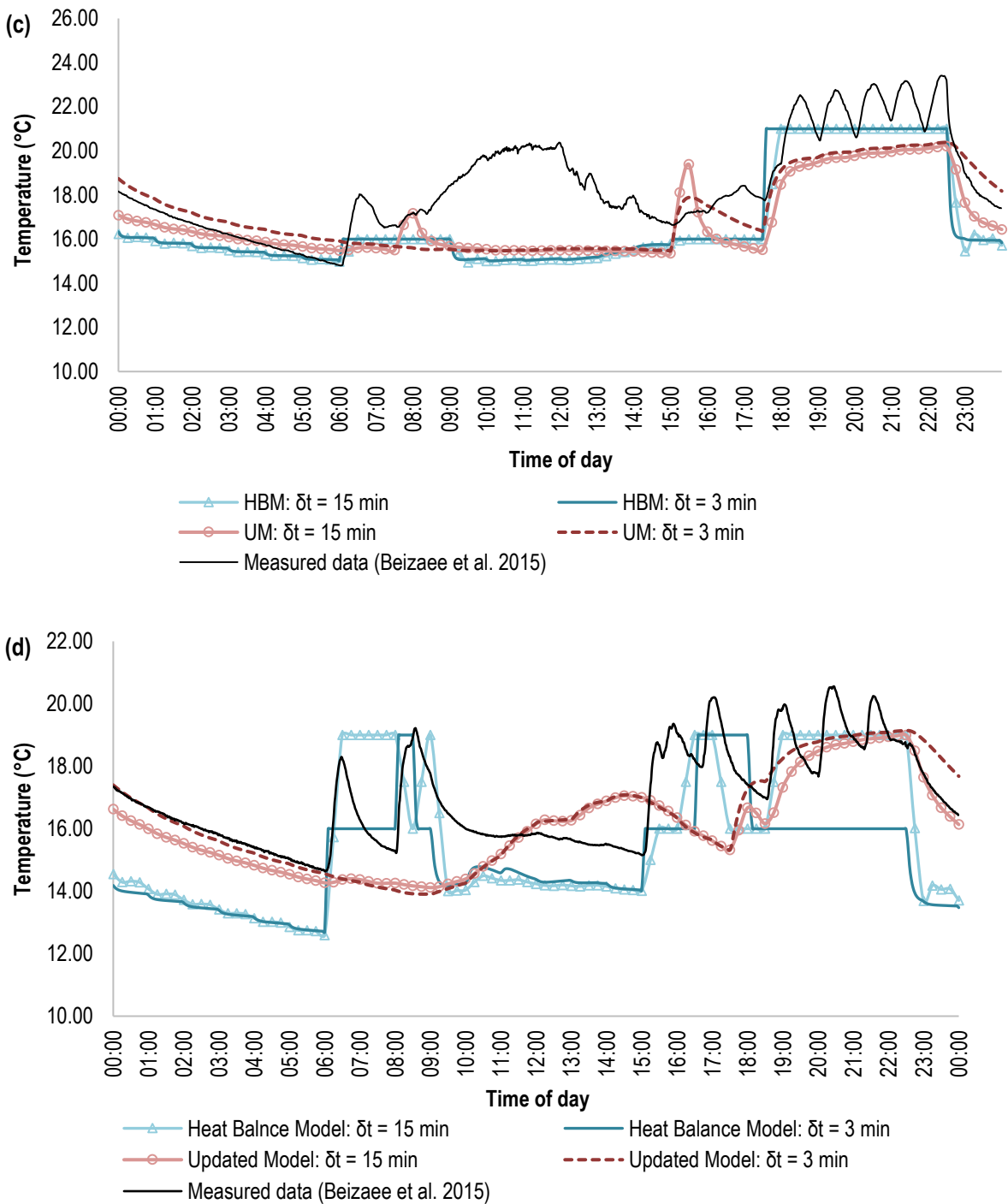
TRNSYS is called to run in Matlab script using generated Building description file (\*.b17) and TRNSYS input file (\*.dck).

### **Step 4: Results analysis**

Results analysis involves the generation of a separate file for the living room and bedroom of each occupancy pattern. These files comprise the ideal temperature profile and modelled profile for each EEM scenario. Each results file is imported into a Microsoft Excel template in which the results for each metric are calculated and figures are generated.

## D.2 Comparison of modelled and measured temperature profile

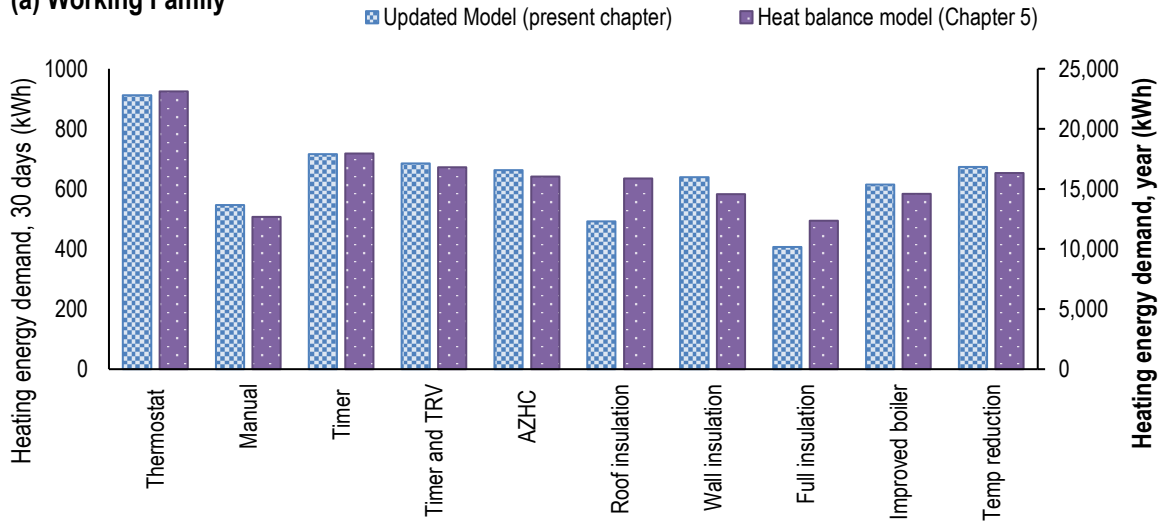




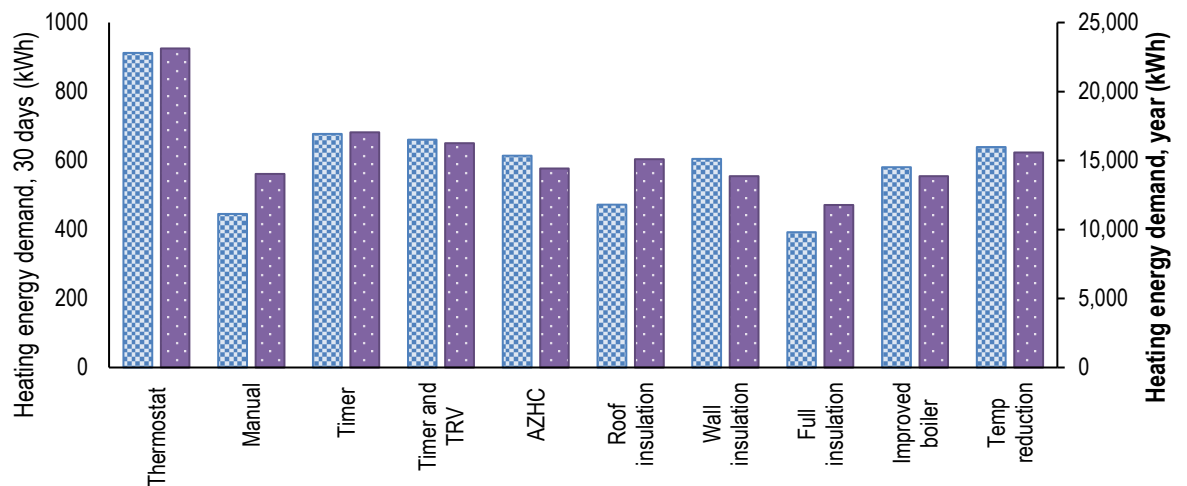
**Figure. D-2** Comparison of temperature profile taken from representative 24 hour period in heat balance model as used in Chapter 5, enhanced model as used in the present chapter and measured data (taken from empirical work by Beizaee et al (2015) (Fig 5 therein)). Profiles are shown for (a) Living room with heating control by heating timer and TRVs (termed ‘conventional control’ by Beizaee et al.), (b) Bedroom with heating control by heating timer and TRVs, (c) Living room with AZHC (termed ‘zonal control’ by Beizaee et al.), and (d) Bedroom with AZHC. All figures show difference between time step ( $\delta t$ ) of 3 minutes and 15 minutes.

### D.3 Comparison of heating demand calculations between building model approaches

(a) Working Family



(b) Working Couple



(c) Daytime-Present Couple

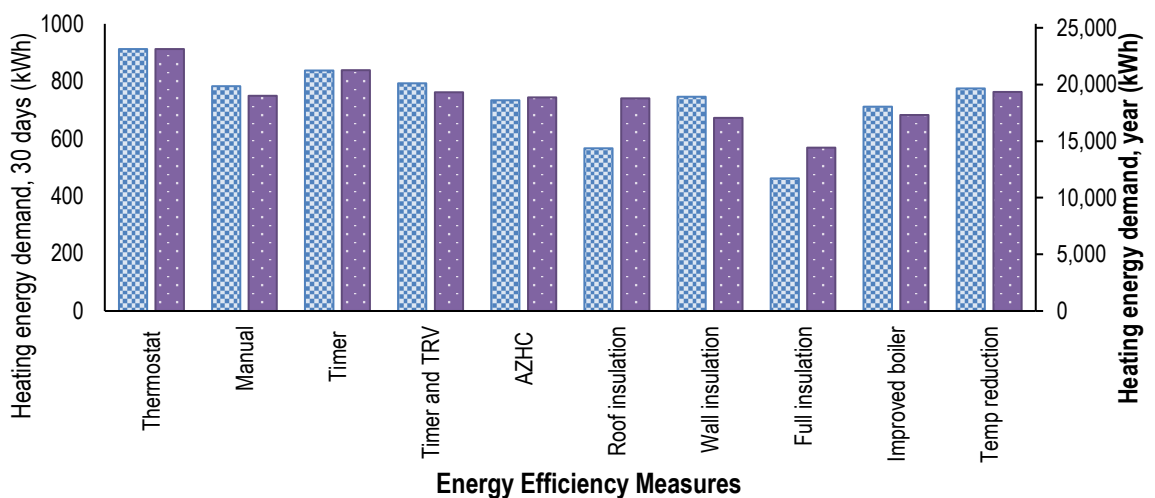


Figure D-3 Comparison of heating energy demand calculated in heat balance model (Chapter 5) and enhanced model (present chapter)