

Rana, K. P. S. & Khan, S. (2008). A DAQ card based mixed signal virtual oscilloscope. *Measurement*, 41(9), pp. 1032-1039. doi: 10.1016/j.measurement.2008.02.005



**CITY UNIVERSITY
LONDON**

[City Research Online](#)

Original citation: Rana, K. P. S. & Khan, S. (2008). A DAQ card based mixed signal virtual oscilloscope. *Measurement*, 41(9), pp. 1032-1039. doi: 10.1016/j.measurement.2008.02.005

Permanent City Research Online URL: <http://openaccess.city.ac.uk/15835/>

Copyright & reuse

City University London has developed City Research Online so that its users may access the research outputs of City University London's staff. Copyright © and Moral Rights for this paper are retained by the individual author(s) and/ or other copyright holders. All material in City Research Online is checked for eligibility for copyright before being made available in the live archive. URLs from City Research Online may be freely distributed and linked to from other web pages.

Versions of research

The version in City Research Online may differ from the final published version. Users are advised to check the Permanent City Research Online URL above for the status of the paper.

Enquiries

If you have any enquiries about any aspect of City Research Online, or if you wish to make contact with the author(s) of this paper, please email the team at publications@city.ac.uk.

A DAQ card based mixed signal virtual oscilloscope

K.P.S. Rana ^{a,*}, S.H. Khan ^b

^a *Instrumentation and Control Engineering Department, Netaji Subhas Institute of Technology, Dwarka, Sector - 3, New Delhi, PIN-110 075, India*

^b *City University, School of Engineering and Mathematical Sciences, Electrical, Electronic and Information Engineering, Northampton Square, London, UK*

Received 1 August 2007; received in revised form 3 December 2007; accepted 20 February 2008

Available online 29 February 2008

Abstract

Complex signals find many applications in SONAR, RADAR, Echo Location Systems and for studying the resonant frequencies. Digital Storage Oscilloscopes (DSO) is used these days for acquisition and display of routine signals. This instrument, found in every measurement laboratory, though potent in displaying simple periodic waveforms like sinusoids fails when frequency-varying time signals are applied. This problem surfaces because the underlying technique of oscilloscope used to trigger the waveform does not acquiesce with complex signals like chirp. Ready solution to this problem is the mixed signal oscilloscope. This is a costly solution and small laboratories cannot afford to have the costly instruments. In this paper, a cost effective DAQ card based mixed signal virtual oscilloscope is proposed to study the complex signals. An intelligent technique, Weighted Hamming Distance (WHD) algorithm was used to accurately trigger the complex waveforms. Also for frequency domain analysis, Joint Time Frequency Analysis (JTFA) techniques were used. A LabVIEWTM based virtual instrument was designed and developed with a capability to acquire, display and analyze the triggered signal. The integrated programming language LabVIEWTM was chosen as it offers many simple ready to use functions. In a way the proposal offers a cost effective, fast and flexible solution to treat the complex signals. The need to create such solutions is the consequence of costly hardware systems. The deficiency of conventional hardware, scheme for the virtual oscilloscope for complex signals with some real time experimental results are presented in this work.

Keywords: Virtual instrumentation; Chirp signal; Data acquisition; Triggering; Complex signals; JTFA

1. Introduction

For the last two decades there has been a tremendous progress in computer technology. Measurement domain is no longer left unaffected. The way measurements are being done is totally revolution-

ized. Computer based measurement or say virtual instrumentation is gradually replacing the costly bench top instrumentation as it offers flexible, fast and cost effective solutions. Various classical instrumentation systems namely Oscilloscope, Multimeters and Spectrum analyzers, etc. are almost phased out by their counter part virtual instrumentation. Our research extends the trend and demonstrates the development of the computer based mixed signal digital oscilloscope. [9,10].

* Corresponding author. Tel.: +91 11 25099050x2167; fax: +91 11 25099022.

E-mail address: kpsrana1@gmail.com (K.P.S. Rana).

Conventional signals such as the sinusoids have a constant frequency and the amplitude only varies with time throughout the signal definition. On the other hand, complex signals can be defined in this context as signals in which all the parameters vary. Fig. 1 shows a typical complex signal i.e. Linear Chirp.

Variation of amplitude and frequency with time can easily be understood by having a look at the signal. This requires a visually stable display of signal. The complex signal offers challenges for acquisition, display and analysis. Even the conventional modern age DSO is not capable of displaying and analyzing complex signals because these instruments employ simple triggering technique like level trigger. The conventional technique of voltage trigger apparently fails when complex signals like chirp are analyzed on DSO. This is due to the very fact that these instruments consider chirp as a conventional sine wave and trigger for each cycle of the sine wave instead of triggering for the complete chirp cycle. This analysis of the chirp signal as several sine waveforms of different frequencies leads the DSO to display them as sinusoids in quick succession. As this rapid change occurs at a very high rate and because of human eye not registering events occurring faster than 1/20th of a second the display appears as several overlapped sine waves. In the recent work [1], a new triggering technique was proposed for the complex signals based on WHD. Subsequent sections present the solution to the problem. For analysis of the complex signals in frequency domain JTFA technique is utilized and implemented [2–6].

DSO uses the level trigger to display the waveform applied to it. This leads to trigger interval and the number of samples for this trigger interval is computed and these numbers of samples are displayed. The DSO considers the interval as the fundamental time period of the whole waveform and thus takes that much samples from its buffer and starts displaying it in quick succession. With simple waveform like a sine wave, level trigger can achieve

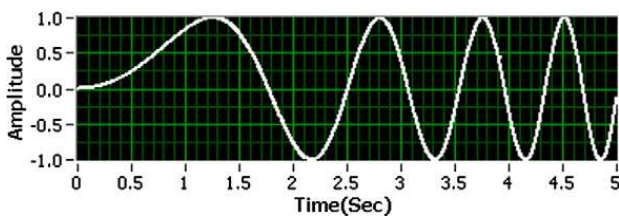

Fig. 1. Chirp waveform.

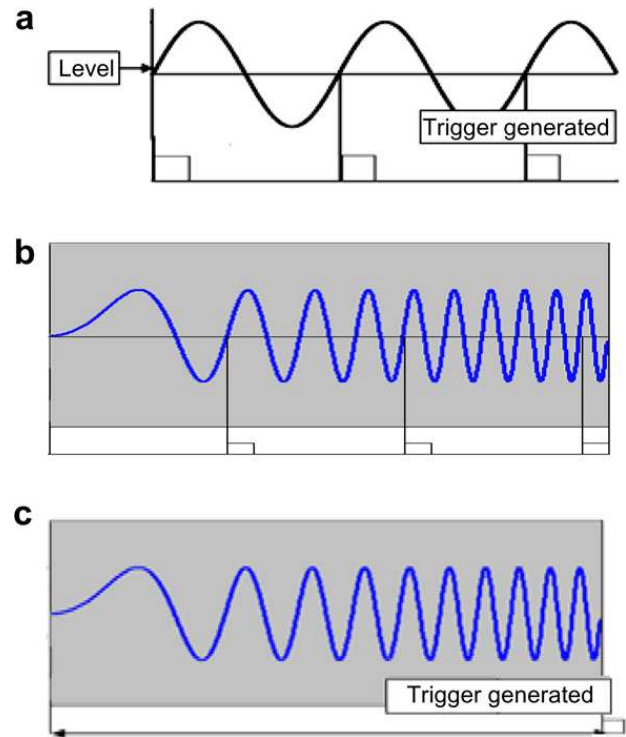

Fig. 2. (a) Level trigger on periodic sine wave. (b) Level trigger application on a chirp signal. (c) Correct trigger for a chirp signal.

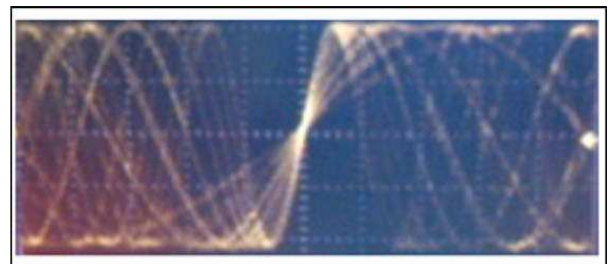

Fig. 3. Visually unstable display of Chirp on DSO.

stable display because trigger interval contains same number of cycles. This is shown in Fig. 2a.

Now for the complex signal as shown in Fig. 2b, level triggering produces a trigger interval having variable number of cycles for the same number of samples/time resulting in a visually unstable display.

The actual trigger interval should be one complete cycle for a chirp signal as indicated in Fig. 2c. Having done this the repeated chirp signal for this time duration will be displayed without any overlapping components as long as the entire time period is displayed.

To observe the shortcomings experimentally in display of complex signals on the oscilloscope, Tektronix dual channel signal generator AFG-3022 (250 MS/s, 25 MHz) was used to generate a chirp

signal by choosing the sweep mode to sine waveform with its frequency varying linearly with respect to time. This signal was fed to Tektronix TDS-2022 (2 GS/s, 200 MHz) dual-channel DSO. The overlapping display as shown in Fig. 3 was observed.

2. Intelligent method of triggering

Accurate triggering lies solely on correct identification of the time period of waveform under consideration. For this purpose, pattern recognition scheme was implemented to identify the pattern in the signal [1] and thus obtain the time period of one complete cycle of the chirp. First, a fixed number of samples ‘N’ are taken as reference pattern. Then the signal is shifted by one sample to form the test pattern. This pattern is then tested for its ‘closeness’ to the reference pattern. ‘Closeness’ can be defined as the distance by which test pattern is away from reference pattern.

WHD is used as the decision function for closeness. Hamming distance is defined for two binary vectors as the number of ‘different’ bits in two given vectors. In WHD the ‘different’ bits are given their binary weighting according to the bit position and their weights are summed up. WHD of two binary n bit number x and a is given by

$$WHD(x, a) = \sum_{k=0}^{n-1} [2^k (x^k \oplus a^k)] \tag{1}$$

If X and A are two binary vectors of n-bits element, then WHD for these two vectors is computed by summing up the element by element WHD and is given by

$$WHD(X, A) = \sum_{\text{element}} WHD(x, a) = \sum_{k=0}^{n-1} [2^k (x^k \oplus a^k)] \tag{2}$$

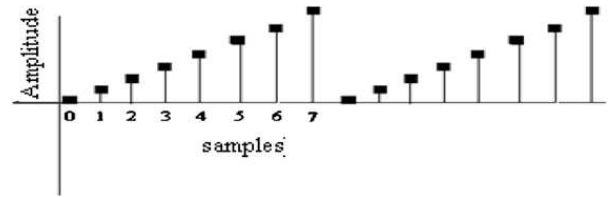

Fig. 4. Test signal.

For a vector of dimension N, the samples are shifted ‘N’ times and its closeness is computed at each shift. When these computations are done, the difference in the signals is found to be minimum (ideally zero when no noise) when the cycle repeated itself. Following are the major steps involved and implemented for intelligent trigger mechanism.

1. Acquiring the long enough signal using DAQ card and to convert the decimal values of samples into binary form.
2. A fixed number (N) of binary samples are stored in array. The stored samples are shifted by a fixed number of samples, n (=1, in this case).
3. The original saved samples and the shifted samples are XORed bit-by-bit. The result is then multiplied by a factor of 2ⁱ, where i represent the position of bit.
4. The summation of all the resulting values gives the WHD for nth shifts.
5. A plot of WHD vs. ‘n’ is made and the minimum is calculated by peak detection method. The difference between two successive minima is the trigger interval in number of samples.
6. The number of samples multiplied by the sampling rate results in trigger interval (in seconds).

As a test case WHD algorithm is implemented for the following triangular waveform in Fig. 4. The waveform is sampled at 8 points per cycle. Each sampled value is 3 bit length. The step by step implementation is given below.

Test signal:	0.01	1.03	2.005	3.0	4.03	5.1	6.07	7.02	
Binary form:	000	001	010	011	100	101	110	111	
Shifted signal									
For WHD (1):	001	010	011	100	101	110	111	000	
WHD (1)=	001+	011+	001+	111+	001+	011+	001+	111=	11000 ₂ = 24 ₁₀
For WHD (2):	010	011	100	101	110	111	000	001	
WHD (2)=	010+	010+	110+	110+	010+	010+	110+	110=	100000 ₂ = 32 ₁₀
For WHD (3):	011	100	101	110	111	000	001	010	
WHD (3)=	011+	101+	111+	101+	011+	101+	111+	101=	101000 ₂ = 40 ₁₀

For WHD (4):	100	101	110	111	000	001	010	011	
WHD (4)=	100+	100+	100+	100+	100+	100+	100+	100=	$100000_2 = 32_{10}$
For WHD (5):	101	110	111	000	001	010	011	100	
WHD(5)=	101+	111+	101+	011+	101+	111+	101+	011=	$101000_2 = 40_{10}$
For WHD (6):	110	111	000	001	010	011	100	101	
WHD (6)=	110+	110+	010+	010+	110+	110+	010+	010=	$100000_2 = 32_{10}$
For WHD (7):	111	000	001	010	011	100	101	110	
WHD (7)=	111+	001+	011+	001+	111+	001+	011+	001=	$11000_2 = 24_{10}$
For WHD (8):	000	001	010	011	100	101	110	111	
WHD (8)=	000+	000+	000+	000+	000+	000+	000+	000=	0

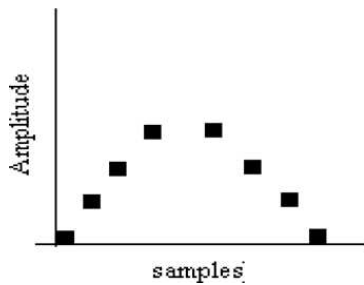

Fig. 5. Output WHD waveform.

WHD waveform is plotted using WHD (1), WHD (2), ..., WHD(8) and the location of the minima gives the triggering interval. Fig. 5 shows the WHD waveform also clearly indicating the trigger interval at 8th sample.

The WHD VI (Fig. 6) was developed for this task. It takes the waveform, whose triggering interval is to be found, and the no of samples, on which computation is to be done, as input and outputs the sample at which minima occurs along with the value of minima and the WHD waveform. For a typical

chirp signal WHD waveform is obtained as shown in Fig. 7. The number of samples between two consecutive minima is equal to the number of samples in one cycle of the waveform. The product of the number of samples with the sampling interval is the triggering interval of the input signal. Thus, the virtual instrument could also display complex waveforms with considerable ease. Fig. 7 shows triggering interval of 5 cycles.

3. Frequency domain analysis

For simple signals the frequency analysis is performed by traditional tools like FFT. For such signals the Fourier Transform works well as their frequency components remain constant throughout the signal existence and hence there is no need for the time – frequency relationship. In case of complex signals the frequency varies with time. FFT fails to analyze these signals as it gives information about the frequency and its amplitude. Time information is

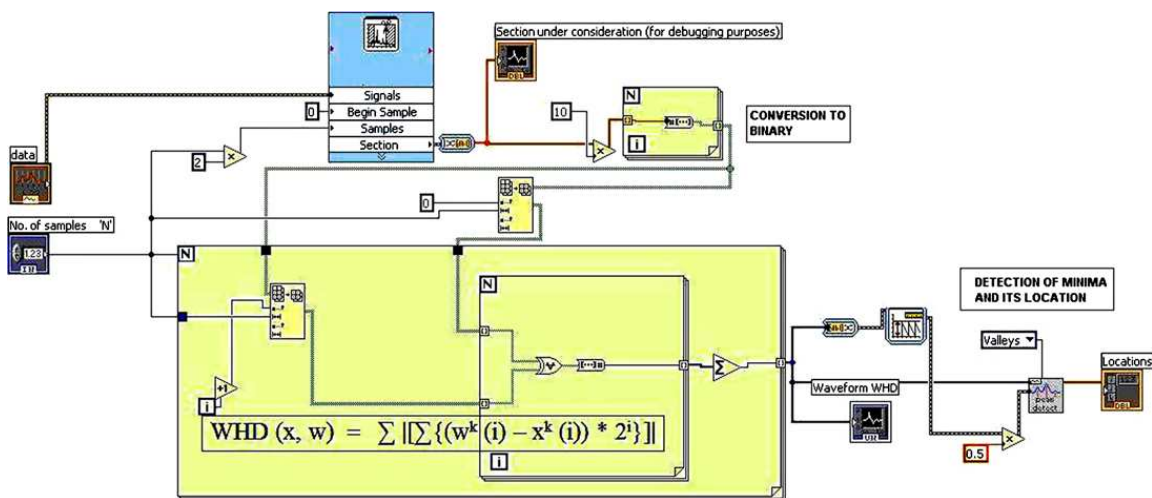

Fig. 6. WHD VI code.

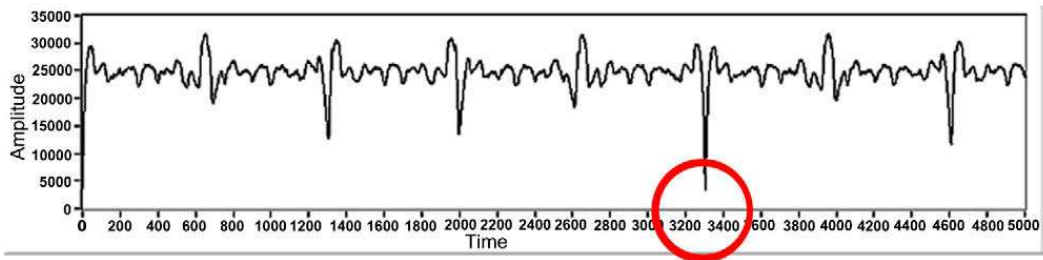

Fig. 7. WHD waveform showing trigger intervals.

lost. In order to overcome this difficulty, there are JTFA tools like Short Time Fourier Transform (STFT) and Wavelet Transform. These are implemented for the signals under consideration. The STFT is a modified form of Fourier Transform. In this technique the signal is multiplied with a window function and their product's Fourier Transform (2).

$$\text{STFT} = \int [x(t) * w(t - \tau)] e^{-j\omega t} dt \quad (3)$$

The main principle behind this technique is that the window function (w) breaks down the signal into segments of small finite duration. The frequency component of the signal during this segment is assumed to be constant. By computing the Fourier Transform for this segment the frequency vs. amplitude information is obtained. Then the window is moved to another segment by a step having the same duration as the previous one giving the frequency component for that segment. Thus the frequency for different time intervals gives time – frequency relationship.

However, there is a disadvantage with this technique. The size of the window function used is fixed, thus STFT will have same resolution for low and high frequencies. Resolution is the certainty by which one can determine time or frequency information. It is generally seen that a larger window leads to a better frequency resolution and a smaller window leads to better time resolution. Thus, it depends upon the user whether he wants frequency or time resolution. Even if there is a need for change of resolution, the user has to do the same manually.

To overcome the resolution problem, a more advanced technique called Wavelet Transform is used these days. In this the window size can be altered, using a scaling parameter ' a '. The equation for Wavelet Transform is given as

$$\text{WT}(a,b) = \frac{1}{\sqrt{a}} \int x(t) \varphi^* \left(\frac{t-b}{a} \right) dt \quad (4)$$

where

a is the scaling parameter,
 b is the translation parameter,
 $x(t)$ is the signal to be analyzed and
 $\varphi(t)$ is the wavelet function

The wavelet function $\varphi(t)$ is known as the mother wavelet. Its scaled and time shifted versions are known as the daughter wavelets. These daughter wavelets having varying size offer different frequency and time resolutions at different frequencies. The scale parameter a represents the frequency component in an inverse relation. Thus the value of scale is inversely proportional to frequency component.

Initially the wavelet function has scale $a = 1$ and is placed at the starting of the signal. The wavelet transform and thus the frequency component of that segment. Then the wavelet function is moved by b steps and the wavelet transform is computed for that segment. This procedure is continued till the end of the signal. Thus Wavelet transform for $a = 1$ and all the time steps till the end of signal gets computed. Similarly the wavelet function is again placed at the start of the signal but with changed value of scale a . The procedure is continued till the Wavelet transform for each scale and time step combination has been computed.

It can be observed that the computation of Wavelet Transform leads to a lot of redundancy. To reduce the redundancy, the scale values and the time steps can be linked using dyadic sampling. $a = 2^n$ and $b = k \cdot 2^n$ where n and k are integers. This leads to reduction in redundancy. This is called Discrete Wavelet Transform (DWT).

4. Implementation

A DAQ card based virtual instrument was designed and developed in LabVIEW™ programming environment. This virtual instrument has the

capability to generate intelligent software trigger as described above for complex waveforms like chirp. The main decisions during design of the virtual instrument are: choosing the data acquisition card and, what is equally important, choosing the set of features the instrument should offer. The choice of the data acquisition card has a great influence on the efficiency of the whole instrument [7,8].

Particular DAQ cards are differentiated by price and, the specification it offers. A low cost NI-PCI-6035E, 16bit, 200KS/s card was chosen. The hardware was programmed at maximum sampling rate. A separate problem is designing software, which, in that case, is the main part of the instru-

ment design phase. The major features of the developed virtual instrument are:

- The capability to acquire and process simple and complex waveforms.
- Dual channel mode: The instrument is capable of displaying two inputs simultaneously and can perform simple math operations between the two.
- Auto set: Runs the WHD code to re-compute the trigger interval for the new signal and thus achieve a stable display. In case, the two inputs do not have the same frequency, the LCM of the trigger intervals of A and B is found to so

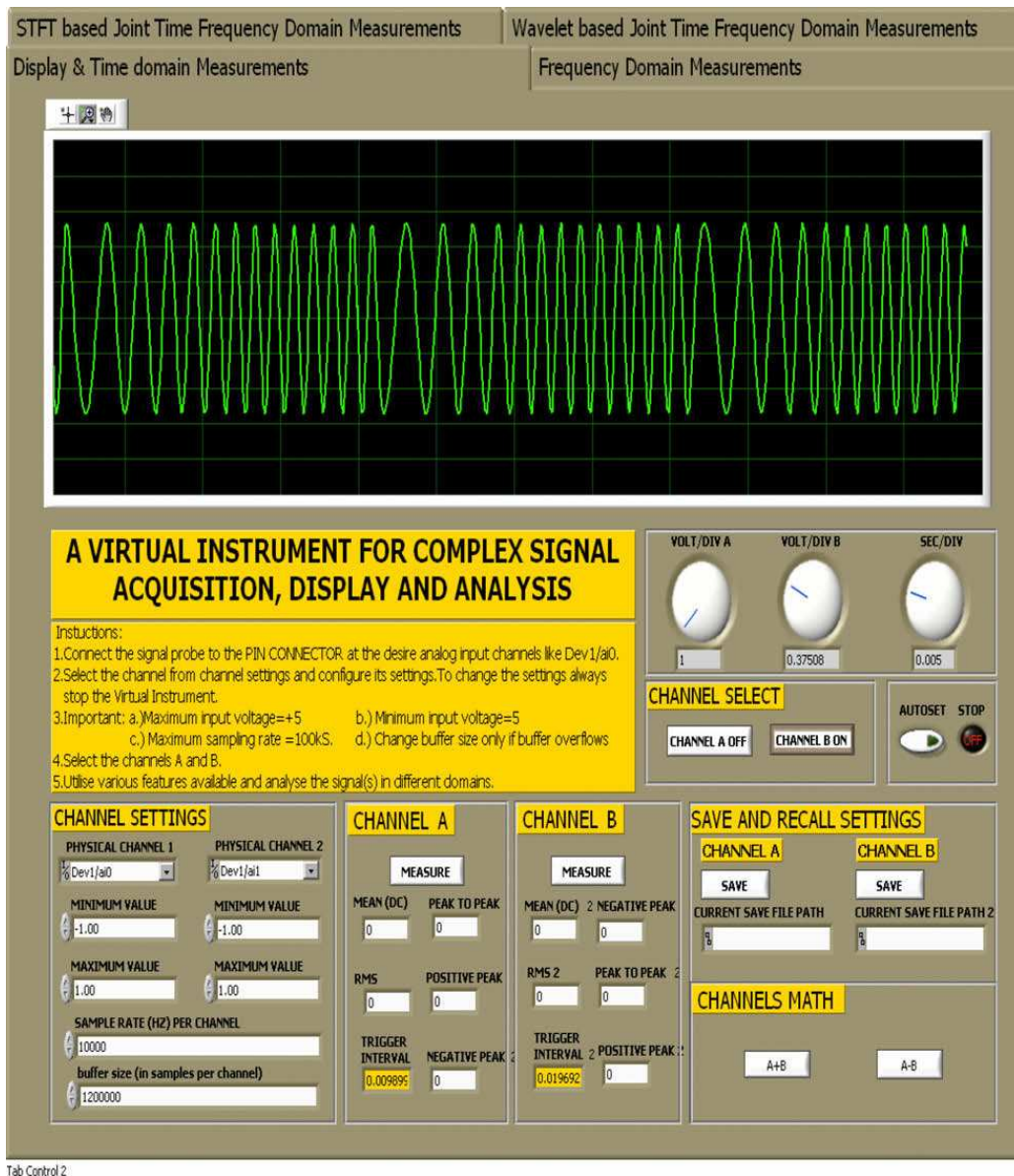

Fig. 8. Front panel of the virtual instrument showing display and time-domain measurements.

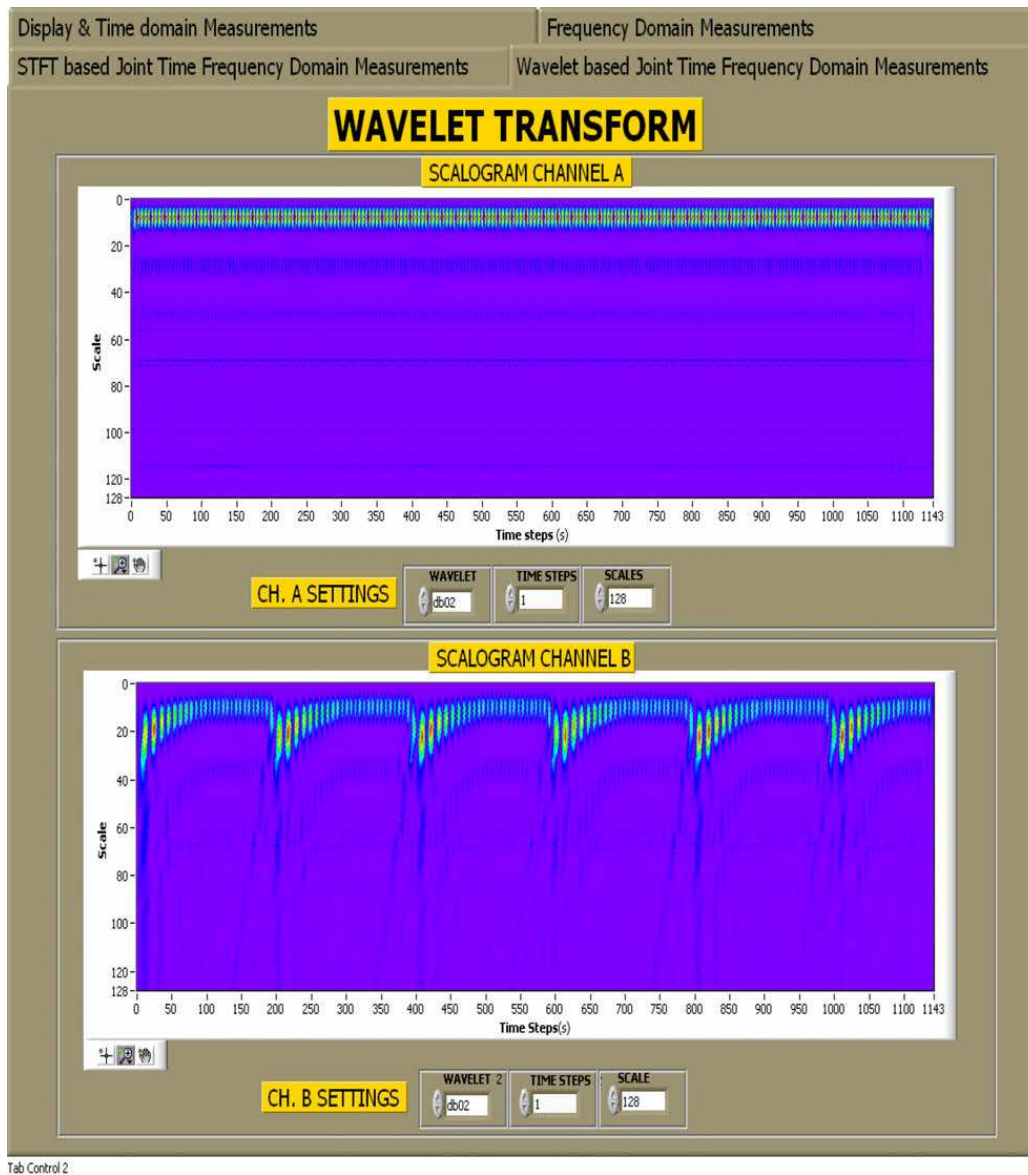

Fig. 9. The results of wavelet transform implemented in the virtual instrument. (Channel A analyzing sine signal and Channel B analyzing a chirp signal).

that integral number of cycles of both the channels can be shown simultaneously.

- Time domain measurements: The signals being displayed in time domain are measured on various parameters
 - Amplitude
 - Peak to peak
 - Mean (DC)
 - RMS.
- Frequency Domain Analysis: The plot of Magnitude vs. frequency, Phase vs. frequency and the facility to choose the windowing function.
- STFT based Joint Time Frequency Analysis (JTFA): The spectrogram with the additional

choices of the plotting the graph with scale in decibels, windowing functions and the window length for STFT analysis.

- Wavelet based Joint Time Frequency Analysis (JTFA): The scalogram which plots scales vs. time steps, choice of time-frequency sampling parameters like time steps and scales and the choice of wavelet functions.

For the frequency domain analysis, DSP toolkit available with LabVIEW™ software was utilized. Standard functions are available in the toolkit. The virtual instrument thus developed is intelligent as it takes different actions with different signals contrary

to a digital storage oscilloscope. Trigger implemented enables us to obtain the correct value of the time period and a stable display. Analysis of complex signals can also be performed using this instrument. Fig. 8 shows the front Panel of the virtual instrument showing Time-domain measurements. Fig. 9 shows the time frequency relationship on both the channels. Channel A analyses the sine signal and channel B analyses the chirp signal. As seen clearly the chirp signal shows the varying frequency with time.

5. Limitations of developed virtual instrument

Samples for few cycles are required to determine the triggering interval. One need to optimize the appropriate sampling rate and the number of samples to be processed. The processing time taken by the WHD technique is directly proportional to the number of samples and hence to the sampling rate as the higher sampling rate leads to the more number of samples per cycle. The time required to compute trigger also depends upon the speed of the computing system. For large amount of data (if high sampling rates us fixed), computationally heavy WHD algorithm and other features for more analysis, the buffer might overflow leading to loss of data. Every time the input waveform is changed user has to do retriggering.

6. Conclusion and discussion

Successful development of the virtual instrument with the capability of acquiring, displaying and analyzing complex signals is done. The instrument over-

comes the shortcomings of the DSOs, found commonly in laboratories, in achieving stable display for complex signals. The developed instrument is cost effective and flexible in nature and had the large number of features to choose from. The modern age technology i.e virtual instrumentation is utilized to showcase the power of the computer towards the measurement systems. The VI developed is expected to go a long way in the instrumentation area.

References

- [1] Shakeb A. Khan, A.K. Agarwala, D.T. Shahani, A new triggering method for oscilloscope based on associative memory technique, in: SCNA 2003 – International Workshop on Soft Computing Techniques in Instrumentation, Measurement and Related Applications.
- [2] Raghuvver M. Rao, Ajit S. Bopardikar, Wavelet transforms: introduction to theory and applications, Pearson Education Asia, 2002.
- [3] Christian Blatter, Wavelets a Primer, University Press, 1998.
- [4] Agostino Abhate, Casimer M. Decusatis, Pankaj K. Das, Wavelets and Subbands, Birkhauser, 2002.
- [5] Amara Graps, An introduction to wavelets, IEEE Computational Science and Engineering Magazine 2 (1995) 2.
- [6] Xiao Ping Zhang, Li-Sheng Tian, Ying-Ning Peng, From wavelet series to discrete wavelet transform, IEEE Transactions on Signal Processing 44 (1) (1996).
- [7] R. Bishop, Lab view 7 Express, second ed., Prentice Hall, New York, 2004.
- [8] L. Wells, J. Travis, Lab View for Everyone, Prentice Hall, Englwood Cliffs, NJ, 1997.
- [9] Zrudsky, Pichler, Virtual instrument for instantaneous power measurement, IEEE Transactions on Instrumentation and Measurement 41 (4) (1992).
- [10] Bhunia, Giri, Kar, et al., A low cost PC based virtual oscilloscope, IEEE Transactions on Education 47 (2) (2004).