

Nadimi, S., Divall, S., Fonseca, J., Goodey, R.J. & Taylor, R.N. (2016). An addendum for particle image velocimetry in centrifuge modelling. Paper presented at the The 3rd European Conference on Physical Modelling in Geotechnics, 1-3 Jun 2016, Nantes, France.



**CITY UNIVERSITY
LONDON**

[City Research Online](http://www.city.ac.uk/researchonline/)

Original citation: Nadimi, S., Divall, S., Fonseca, J., Goodey, R.J. & Taylor, R.N. (2016). An addendum for particle image velocimetry in centrifuge modelling. Paper presented at the The 3rd European Conference on Physical Modelling in Geotechnics, 1-3 Jun 2016, Nantes, France.

Permanent City Research Online URL: <http://openaccess.city.ac.uk/14874/>

Copyright & reuse

City University London has developed City Research Online so that its users may access the research outputs of City University London's staff. Copyright © and Moral Rights for this paper are retained by the individual author(s) and/ or other copyright holders. All material in City Research Online is checked for eligibility for copyright before being made available in the live archive. URLs from City Research Online may be freely distributed and linked to from other web pages.

Versions of research

The version in City Research Online may differ from the final published version. Users are advised to check the Permanent City Research Online URL above for the status of the paper.

Enquiries

If you have any enquiries about any aspect of City Research Online, or if you wish to make contact with the author(s) of this paper, please email the team at publications@city.ac.uk.

An addendum for particle image velocimetry in centrifuge modelling

S. Nadimi, S. Divall, J. Fonseca, R. Goodey & R.N. Taylor
City University London, UK

ABSTRACT: Image-based analysis is a growing field in geotechnical engineering and has a wide range of applications from measuring particle size distribution to observing the three dimensional internal deformation of granular materials. In centrifuge modelling, pre-failure deformation can be captured from the visible vertical plane of the models. This paper describes a new set-up for measuring a two dimensional displacement field using particle image velocimetry (PIV). The system makes use of the texture (intensity of pixel) of images to determine the accurate pattern of pre-failure ground movements. A complementary metal oxide semiconductor (CMOS) sensor is employed rather than a charged couple device (CCD) sensor used in previous studies. Three examples are presented: (1) synthetic experiment using a sliding bed equipped with LVDT behind the window of a strong box to make and measure controlled displacements; (2) strip footing test on glass ballotini under vertical loading; (3) ground movement generated during a shaft construction in clay. These examples provide a range of tests with artificial texture and demonstrate the most important parameters governing the experimental set-up and image analysis. The possibility of using PIV for grain scale investigations is discussed. The study highlights the benefits of new technology and provides guidelines to minimise artefacts in image processing.

1 INTRODUCTION

1.1 Image-based analysis in geotechnics

Image-based techniques present a unique opportunity for presenting an accurate geometrical description of the soil behaviour in geotechnical testing without the need for direct sample contact. Various techniques have been developed to process 2D planar and 3D volumetric images and measure deformation. Stanier et al. (2015) describes the recent advances in algorithms for 2D image processing. Take (2015) presents 2.5D method for field monitoring of surface settlement using six digital cameras. Fonseca et al. (2013) characterised the internal structure of soil using 3D x-ray images. Nadimi et al. (2015) employed image-based meshing to present microstructure of a sand in computational domain. All the above studies used images of soil as input data.

1.2 Application in centrifuge modelling

A key development in geotechnical centrifuge modelling has been to record pre-failure deformation from the vertical plane of a soil model visible through a clear Perspex window using digital image analysis techniques pioneered by Taylor et al.

(1998). This technique relied on the tracking of artificial targets. Particle Image Velocimetry (PIV) also known as Digital Image Correlation (DIC) uses image pixel intensity values to infer incremental displacements and strain fields. This technique has been used widely in computational fluid dynamics to map out spatial distribution of flowing particles and has been adopted by White et al. (2003) for application to centrifuge testing.

The area of interest is discretised into a mesh. The incremental displacement can be found by searching for the pixel intensity values (image texture) of an element in a target image that matches with a reference image. The assessment of texture similarity is performed using a cross correlation framework. This has become a standard technique for centrifuge testing.

A new set-up has been developed for centrifuge modelling which can reduce costs. Open-source software and low cost hardware provide an efficient image-based system for measuring displacement fields in geotechnical monitoring and testing. Three examples are described that assess the performance of the system. Finally, the possibility of quantifying particle-scale behaviour within large-scale observation of boundary value problems is investigated.

2 NEW SET-UP

2.1 Hardware

The camera is the main hardware component. There are generally two main types of imaging sensors incorporated into cameras: charged couple device (CCD) and complementary metal oxide semiconductor (CMOS). Figure 1 shows the mechanism of both sensors. CMOS technology, also referred to as Active Pixel Sensor (APS), presents the opportunity to integrate millions of transistors on a single silicon circuit which leads to a large array of pixels, each with its own readout amplifiers, whereas in a CCD sensor, a single amplifier converts the charge into a readout voltage. The main advantages of CMOS compared to CCD for instrumentation are compactness, low mass, low power and radiation hardness, as noted by Waltham (2013). But, CMOS tend to have increased level of noise over CCD, as separate amplifiers are used for each pixel.

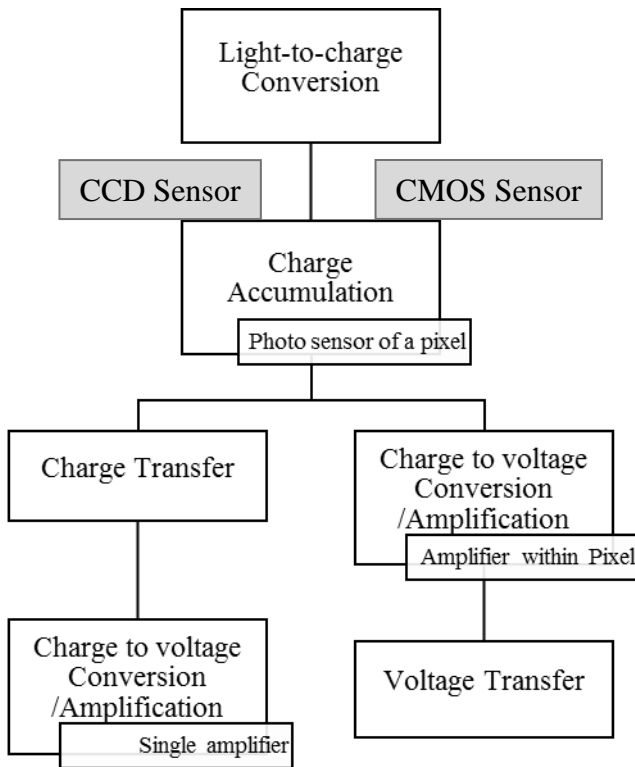

Figure 1. Difference between mechanisms of CCD and CMOS sensors.

The error induced by CCD sensor for PIV application was reported by Legrand et al. (2014). This includes shortcomings in frame transfer and generating readout smearing due to leak out of charges.

Advances in technology over the past decade have significantly reduced the gap between the two types of sensors. Here, the five-megapixel low-noise CMOS sensor that can achieve CCD image quality (based on signal-to-noise ratio and low-light sensitivity) while preserving the size, cost, and integration advantages of CMOS, incorporated into the Imaging Source DFK 72AUC02 colour camera has been em-

ployed. It has an active imaging pixel array of 2592H×1944V with external dimensions of 36×36×25mm and mass of 70g (Figure 2). It is capable of capturing 6 images per second.

The sensitivity of a sensor can be presented as the ratio of incident photons to detected photons (quantum efficiency) with respect to wavelength of light. The spectral sensitivity of the sensor used in this study is shown in Figure 3. This information can be used for pre-processing of images which will be explained later.

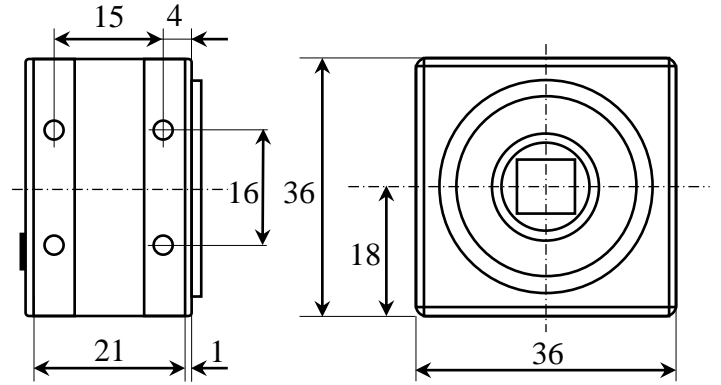

Figure 2. Dimensional Diagram for camera used here.

The choice of shutter is important for recording of dynamic events and rapid movement of rigid bodies. As the intention was to model quasi-static events, the rolling shutter was used.

In order to ensure adequate image contrast, an LED strip light was used to illuminate the vertical visible plane of the model. The light during flight can be adjusted using a dimmable 3 channel LED driver which is controlled via a remote switch in the centrifuge control room. This has a lower power consumption and lower operating temperature compared with the fluorescent light tubes previously used.

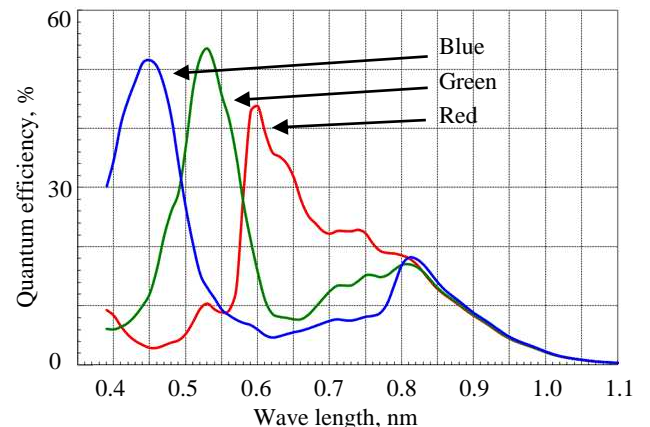

Figure 3. Spectral response of CMOS in DFK 72AUC02

2.2 Software

Two programs are required, 1) Image Acquisition, 2) Image Analysis. A LabVIEW based virtual instru-

ment has been developed for image acquisition which allows the real-time preview of video streams, control of readout colour signals, size of field of view (FOV), resolution of images, remote capture and storage of data.

Regarding PIV analysis, there are several open source and closed source free PIV codes to process the captured images: e.g. GeoPIV (White et al. 2003), OpenPIV (Taylor et al. 2010), PIVlab (Thielicke & Stamhuis, 2014) and GeoPIV-RG (Stainer et al. 2015). In the later code, a first order shape function was introduced which allows the element to deform. This provides better prediction for geotechnical applications, in particular the response of carbonate sand which shows high compressibility. In the next section three examples are presented and the adopted PIV algorithm is stated for each case.

3 APPLICATIONS

3.1 Synthetic experiment

In order to verify the performance of the set-up, a series of synthetic experiments has been conducted. These experiments involved the controlled movement of a sliding bed equipped with an LVDT (Linear Variable Differential Transformer) behind the window of a strong box to consider the effect of

window thickness on refraction of light and measured displacements. This case also investigates the effect of element size and image texture on PIV precision.

Two experiments are reported here with different locations for the moving plane: a) at the bottom of FOV and b) at the middle of FOV. Known targets have been machined using a CNC mill with a positional precision of $15\mu\text{m}$ on the inner side of window. For each test, six PIV analyses were carried out using GeoPIV code (zero-order deformation), in which the image was covered by 10×10 , 20×20 , 30×30 , 40×40 , 50×50 , 60×60 pixels elements, respectively. As noted by White et al. (2003) a larger PIV mesh improves precision, but where an element contains both moving and constant displacement zones, e.g. shear bands in geotechnical events, the precision reduces. It is suggested that the mesh should be matched with the deformation zone. Figure 4 shows a general view of this case, including camera, FOV, sliding bed, LVDT and PIV result of first experiment. There was a discrepancy of $5\mu\text{m}$ for the first experiment and $3\mu\text{m}$ for the second experiment between PIV results and LVDT readings.

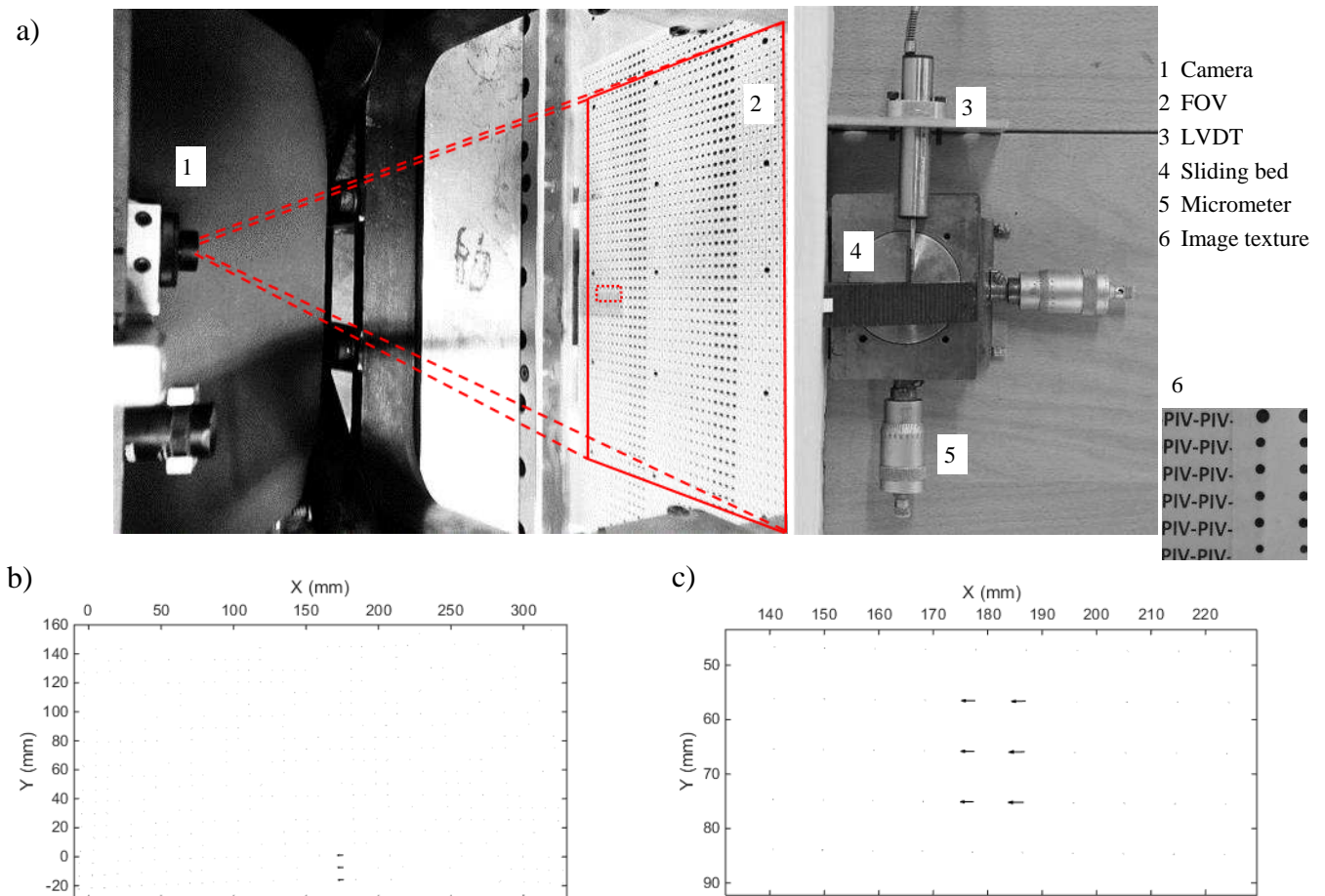

Figure 4. Synthetic experiment, a) set-up, including camera, sliding bed, strongbox window and LVDT; b) displacement arrows for case a; c) zoomed view of case b.

3.2 Ballotini-footing interaction

The interaction of a strip footing on a sample of uniform graded glass ballotini was used to investigate the sensitivity of a granular material to rapid increase of stress level in centrifuge modelling. Here, image processing of this case study is presented. The detail of physical modelling was described by Nadimi et al. (2016).

The terminology ‘texture mapping’ is used to describe how an image texture was obtained. Figure 5(a) shows two image textures that have been assessed for this experiment. Image texture 1 was mapped by pouring strip lines of black dyed glass ballotini. Image texture 2 is a mix of dyed and non-dyed glass ballotini. Information about the physical and mechanical behaviour of dyed materials and different methods for granular mixing are provided in Nadimi et al. (2016).

To characterise the texture of an input image, a statistical measure of randomness (entropy) has been used, defined as:

$$E = -\sum P(x) \cdot \log_2 P(x) \quad (1)$$

$P(x)$ is the probability mass function and, in this case, contains the histogram counts. E is a scalar value representing entropy of image. The value of E is about 6.5 for both cases, i.e. image texture 1 and

image texture 2. But in the case of strip lines, the probability of repetition of texture in the neighbouring element is high which can lead to some errors in horizontal displacements. Therefore, granular mixing was chosen as a texture mapping method.

The PIV analysis has been conducted using GeoPIV. The mesh contains 321 elements with the size of 40×40 pixels. The Region of Interest (RoI) is shown in Figure 5(b). The vertical and horizontal displacements are shown in Figure 5(c) and 5(d), respectively. Figure 5(e) represents the deformation mechanism using resultant displacement arrows. This provides the required information for comparison of deformation mechanisms in varied gravity environment.

It is important to note that the PIV results for elements that contain known targets can be miscalculated as the known target does not move with soil movement. Therefore, it is suggested the elements with known targets should be excluded from the final results. The GeoPIV-RG provides a function to exclude known targets from the mesh.

3.3 Shaft construction in clay

An investigation into the ground movements generated during a shaft construction in clay, this case aims to understand how various spatial layouts of a

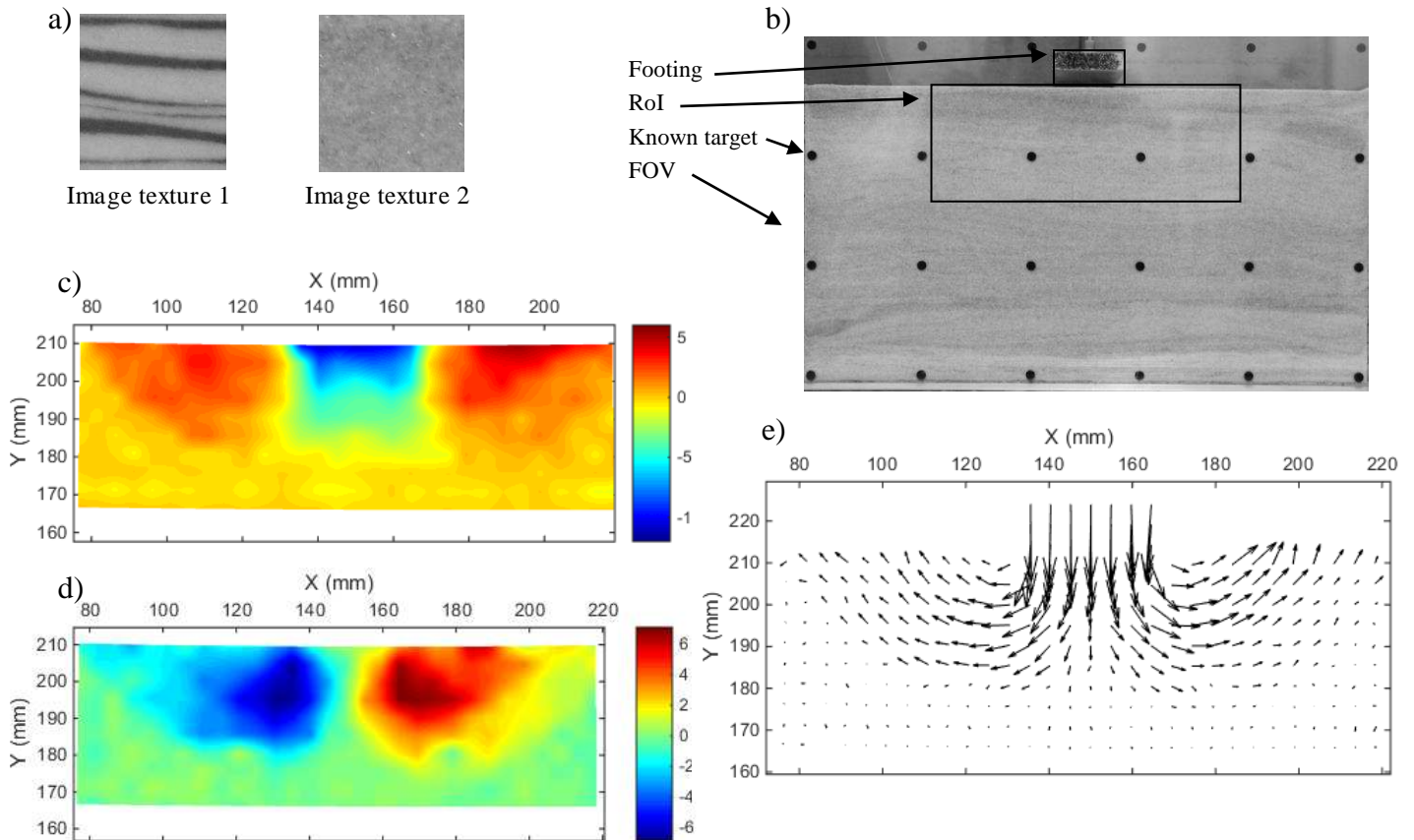

Figure 5. Ballotini-footing interaction, a) Image textures, b) general view, c) vertical displacement, d) horizontal displacement, e) resultant displacement arrows.

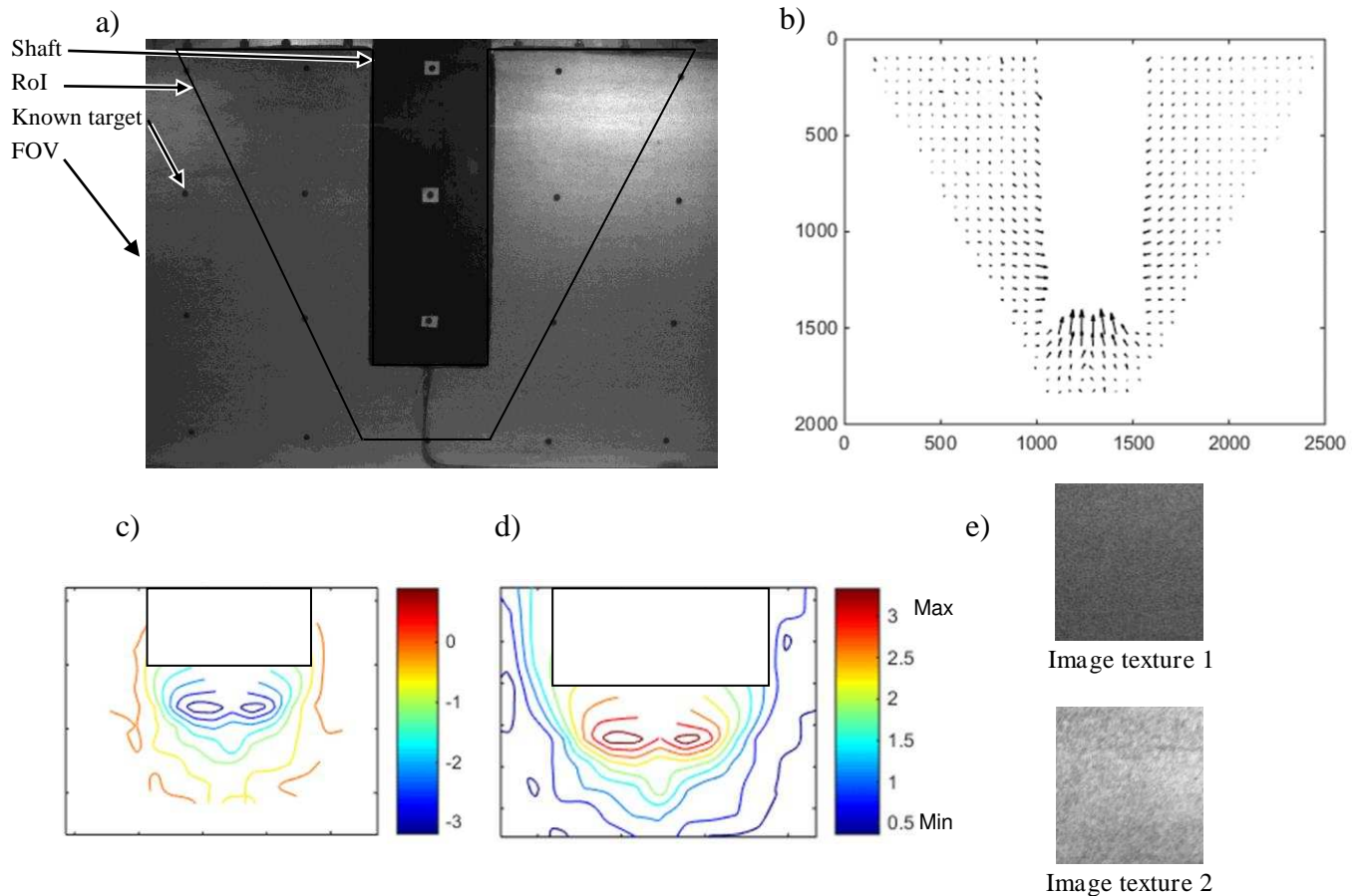

Figure 6. Shaft construction in clay, a) a general view of captured image, b) surface vertical displacement c) deformation around bottom of shaft, e) image texture.

shaft impact on an existing tunnel lining. More details about the tests were reported by Divall and Goodey (2016).

The texture mapping was conducted using a gravity fed air brush gun. Dyed sand particles have been applied to the vertical plane of the soil model. In order to investigate the importance of illumination on image texture quality, lighting intensity was managed to be higher in the right side of captured images compared with the left side. This is shown in image texture 1 and 2 in Figure 6(e). Texture analysing shows a value of 6.92 for the right side of image and 5.56 for the left side of image. The PIV analysis has been conducted using GeoPIV. The left side shows higher level of noise due to lower intensity of light.

Figure 6(a) shows a general view of test. The deformation pattern is presented in Figure 6(b). Vertical and resultant displacement contours around the bottom of the shaft, where the conventional instrumentation is not possible to use, are shown in Figure 6(c) and 6(d), respectively.

4 POTENTIAL SOURCES OF ERROR

The potential sources of error can be related to hardware and software. Real cameras have some

level of noise which depends on the sensor type. The level of noise can be modified by altering the shutter type and light intensity. Noise in the sensor is related in part to the signal level detected on the sensor. It should be noted that for those channels in which the sensitivity is lower and the subsequent amplification higher, the noise in those channels will also be amplified and will be higher. Therefore, to reduce the level of noise, colour channels with higher sensitivity should be used. This can be conducted during image acquisition or pre-processing of the images.

As the curvature of a lens surface introduces some distortion in images, it is important that the RoI is within the location of control targets.

Image texture, element size, and texture quality can affect the results. The absence of texture in an element leads to some noise for that element. An image with high randomness can have elements with multiple correlation peaks due to a repeating pattern. Therefore a good texture should have high randomness without repetition in neighbouring elements. As mentioned before, the larger the element size, the higher the precision, but it has to be taken into account that elements on a shear band may show some errors. Therefore, the mesh has to be carefully generated considering the deformation mechanism.

5 MICROSACLE STUDIES

The possibility of investigating particle scale behaviour by observation of boundary value problems using the same series of images is discussed here. This has been raised by Stainer and White (2013).

Particle rearrangement, including rotation and translation, is known to control the failure of geomaterials. Oda and Kazame (1998) explored the significance of particle rotation on the granular response and have shown that particles in a shear band experience significant rotation. The question is raised as to whether the current PIV code can capture particle rotation and translation.

In order to perform this, the domain needs to be discretised for individual particles and texture needs to be mapped for each particles. O'Sullivan et al (2003) proposed an approach for capturing particle rotation using the discrete element method (DEM). This can be adopted for quantifying particle rotation in centrifuge modelling.

The ratio of pixel size over mean diameter of particles is a common parameter for describing the resolution of images for micro-scale studies. A larger the number of particles in an assembly leads to lower resolution. Therefore, the larger the FOV, the lower the number of pixels per particle. Therefore, there is a need to employ a camera with a larger sensor or decrease the FOV to make particle scale studies possible.

6 CONCLUSIONS

This paper has provided an updated addendum for PIV analysis for geotechnical centrifuge modelling. Three examples have been presented. Important parameters governing performance of hardware and software have been discussed. Camera sensor, shutter and illumination have to be carefully chosen and optimised. Image texture, element size and control targets may affect the precision. The important findings include:

- A simple method for texture analysis that can be carried out before testing to avoid repeating texture problems.
- To reduce the noise of images, colour channels with low efficiency can be filtered out during acquisition or using MATLAB functions.
- In clayey soil, spraying dyed sand using a gravity fed air brush and rolling them into soil body can provide adequate texture.

ACKNOWLEDGMENTS

The first author would like to express thanks to City University London for his doctoral scholarship.

REFERENCES

- Divall, S. & Goodey, R. 2016. Shaft construction in clay. Proceeding of the 3rd European Conference on Physical Modelling in Geotechnics, Nantes, France.
- Fonseca, J., O'Sullivan, C., Coop, M.R. & Lee, P.D. 2013. Quantifying the evolution of soil fabric during shearing using scalar parameters. *Géotechnique* 63 (10): 818-829.
- Legrand, M., Nogueira, J., Vargas, A.A., Ventas, R. & Rodriguez-Hidalgo, M.C. 2014. CCD image sensor induced error in PIV application. *Meas. Sci. Technol.* 25, 065207.
- Nadimi, S., Fonseca, J., Barreto, D. & Taylor, R.N. 2016. Revisiting the particle size effects in centrifuge modelling. Proceeding of the 3rd European Conference on Physical Modelling in Geotechnics, Nantes, France.
- Nadimi, S., Fonseca, J., Taylor, R.N. (2015a). A microstructure-based finite element analysis of the response of sand, 6th Int. Sym. on deformation characteristics of geomaterials, Buenos Aires, Argentina.
- Oda and Kazame, 1998. Microstructure of shear bands and its relation to the mechanisms of dilatancy and failure of dense granular soils, *Géotechnique* 48(4): 465-481.
- O'Sullivan C., Bray J.D., Li S.F. 2003. A new approach for calculating strain for particulate media, *International Journal for Numerical and Analytical Methods in Geomechanics* 27: 859-877
- Stanier, S.A. & White, D.J. 2013. Improved image-based deformation measurement for the centrifuge environment. *Geotechnical Testing Journal* 36(6): 915-927.
- Stanier, S.A. Blaber, J., Take, W.A. & White, D.J. 2015. Improved image based deformation measurement for geotechnical applications. *Canadian Geotechnical Journal* (In press).
- Take W. A. 2015. Thirty-Sixth Canadian Geotechnical Colloquium: Advances in visualization of geotechnical processes through digital image correlation. *Canadian Geotechnical Journal* 52(9):1199-1220.
- Taylor, R.N., Grant, R., Robson, S. & Kuwano, J. 1998. An image analysis system for determining plane and 3D displacement in soil models. Proceeding of the International Conference on Centrifuge Modelling, Centrifuge 98, Tokyo, Japan.
- Taylor, Z.J.; Gurka, R.; Kopp, G.A. & Liberzon, A. 2010. Long-Duration Time-Resolved PIV to study unsteady aerodynamics, *IEEE Transactions on Instrumentation and Measurement* 59(12): 3262-3269.
- Thielicke, W. & Stamhuis, E.J. 2014. PIVlab-Towards user-friendly, affordable and accurate Digital Particle Image Velocimetry in MATLAB. *Journal of Open Research Software* 2(1): e30.
- Waltham, N. 2013. CCD and CMOS sensors. In: Huber, M.C.E., Pauluhn, A., Culhane, J.L., Timothy, J.G., Wilhelm, K. & Zehnder, A. *Observing Photons in Space*. ISSI Scientific Report Series. New York: Springer. pp. 423-442.
- White, D.J., Take, W., & Bolton, M. 2003. Soil deformation measurement using particle image velocimetry (PIV) and photogrammetry. *Géotechnique* 53(7): 619-631.