

Kyriacou, P. A., Crerar-Gilbert, A., Langford, R. M. & Jones, D. P. (2009). Measurement of photoplethysmographic signals in human abdominal organs. *Measurement*, 42(7), pp. 1027-1031.  
doi: 10.1016/j.measurement.2009.03.004



**CITY UNIVERSITY  
LONDON**

[City Research Online](#)

**Original citation:** Kyriacou, P. A., Crerar-Gilbert, A., Langford, R. M. & Jones, D. P. (2009). Measurement of photoplethysmographic signals in human abdominal organs. *Measurement*, 42(7), pp. 1027-1031. doi: 10.1016/j.measurement.2009.03.004

**Permanent City Research Online URL:** <http://openaccess.city.ac.uk/13356/>

### **Copyright & reuse**

City University London has developed City Research Online so that its users may access the research outputs of City University London's staff. Copyright © and Moral Rights for this paper are retained by the individual author(s) and/ or other copyright holders. All material in City Research Online is checked for eligibility for copyright before being made available in the live archive. URLs from City Research Online may be freely distributed and linked to from other web pages.

### **Versions of research**

The version in City Research Online may differ from the final published version. Users are advised to check the Permanent City Research Online URL above for the status of the paper.

### **Enquiries**

If you have any enquiries about any aspect of City Research Online, or if you wish to make contact with the author(s) of this paper, please email the team at [publications@city.ac.uk](mailto:publications@city.ac.uk).

# Measurement of photoplethysmographic signals in human abdominal organs

P.A. Kyriacou<sup>a,\*</sup>, A. Crerar-Gilbert<sup>b</sup>, R.M. Langford<sup>c</sup>, D.P. Jones<sup>a</sup>

<sup>a</sup>*School of Engineering and Mathematical Sciences, City University, London EC1V 0HB, UK*

<sup>b</sup>*Department of Anaesthesia, St. George's Hospital, London, UK*

<sup>c</sup>*Anaesthetic Laboratory & Department, St. Bartholomew's Hospital, London, UK*

---

## A B S T R A C T

There is a need for reliable continuous monitoring of abdominal organ oxygen saturation (SpO<sub>2</sub>). Splanchnic ischaemia may ultimately lead to cellular hypoxia and necrosis and contribute to the development of multiple organ failure and increased mortality. A reflectance electro-optical photoplethysmographic (PPG) probe and signal processing system were developed. Satisfactory PPG signals from abdominal organs (bowel, liver and kidney) and the finger were obtained from 12 anaesthetised patients. There were no statistically significant differences between the average PPG amplitudes recorded from the abdominal organs and those obtained simultaneously from the finger. These observations suggest that pulse oximetry can be a valid monitoring technique for abdominal organs such as the bowel, liver and kidney.

---

### Keywords:

Pulse oximetry

Photoplethysmography

PPG

Splanchnic perfusion

Abdominal perfusion

Organ perfusion

---

## 1. Introduction

Measurement of blood oxygen saturation (SpO<sub>2</sub>) from an extremity such as the finger cannot always accurately reflect splanchnic oxygen saturation values. In many critically ill patients, poor tissue oxygenation is due to disordered regional distribution of blood flow, despite high global blood flow and oxygen delivery. Splanchnic ischaemia could ultimately lead to cellular hypoxia and necrosis and could well contribute to the development of multiple organ failure and increased mortality [6]. Rapid detection of a significant change in tissue oxygenation could enable earlier and more successful intervention and restoration of splanchnic blood flow and could improve survival in critically ill patients [6].

Techniques used to measure tissue oxygenation such as polarographic oxygen electrodes, luminescent oxygen probes, magnetic resonance spectroscopy and positron

emission tomography remain research tools [6]. Fluid tonometry for estimating intestinal hypoxia, is expensive, intermittent, operator dependent and time consuming [6]. Methods such as laser Doppler, Doppler ultrasound, and intravenous fluorescein have been previously explored to assess intestinal ischaemia in animals [9,3,2,7]. Many of these techniques are complex and expensive and none of them directly measures oxygenation. Therefore, there is a need for a simple, reliable, and continuous method for estimating abdominal organ SpO<sub>2</sub>. Animal studies have also shown that pulse oximetry could be used to monitor intestinal oxygen saturation [7]. The feasibility of estimating blood oxygen saturation in humans has been demonstrated by a study using a commercial transmission pulse oximeter on the colon [8]. However, there are difficulties in applying commercial pulse oximeters to measurements in abdominal human organs. The design of current commercial probes makes them difficult or not possible to apply onto the solid abdominal organs, difficult to sterilise and not suitable for leaving in the abdomen for prolonged postoperative monitoring.

---

\* Corresponding author. Tel.: +44 207040 8131.

E-mail address: P.Kyriacou@city.ac.uk (P.A. Kyriacou).

Pulse oximetry has been one of the most significant technological advances in clinical monitoring in the last two decades [10]. Pulse oximetry is a non-invasive photometric technique (pulse oximeter sensors are usually placed on the digit or earlobe that provides information about the arterial blood oxygen saturation ( $SpO_2$ ) and heart rate, and has widespread clinical applications. Pulse oximeters estimate arterial oxygen saturation by shining light at two different wavelengths, red and infrared, through vascular tissue. In this method the pulsatile photoplethysmographic (ac PPG) signal associated with cardiac contraction is assumed to be attributable solely to the arterial blood component. The amplitudes of the red and infrared ac PPG signals are sensitive to changes in arterial oxygen saturation because of differences in the light absorption of oxygenated and deoxygenated haemoglobin at these two wavelengths. From the ratios of these amplitudes, and the corresponding dc PPG components, arterial blood oxygen saturation is estimated. Hence, the technique of pulse oximetry relies on the presence of adequate peripheral arterial pulsations, which are detected as photoplethysmographic (PPG) signals.

As a preliminary to constructing a suitable pulse oximeter for monitoring abdominal organ  $SpO_2$ , this paper describes the development and application of a system for the measurement of PPG signals from the surfaces of the bowel, liver and kidney. Some of the clinical results of this study have been reported by Crerar-gilbert et al. [1]. The aim of this paper is to discuss in more depth the instrumentation and physiological measurement aspects of the work and to present some quantitative results.

## 2. Methods

### 2.1. Instrumentation

A reflectance electro-optical abdominal organ PPG probe comprising miniature infrared (880 nm) and red (655 nm) emitters (ELCOS GmbH) and a photodetector has been constructed (Fig. 1). Constant current circuits provided a total of 40 mA of pulse current to each pair of emitters in parallel. The silicon diode photodetector is

mounted between the red and infrared emitters to detect radiation back scattered by the tissue. A separation of 5 mm between the emitters and the photodetector provides good signal-to-noise ratio and adequate pulsatile signals. The emitters and the photodetector are mounted on a thin copper board ( $20 \times 3.5 \times 1.0$  mm). A six-core cable carries the power to the emitters in the probe from the PPG processing system and also the detected PPG signals from the photodetector. This cable is electrically screened to minimise electromagnetic interference. The probe was designed to fit into a conventional disposable transparent gastric tube, 20 French gauge, which is sealed at the distal end [4,5]. A reflectance finger PPG probe, identical to the abdominal organ probe, was also constructed to facilitate comparisons between the two sites, abdominal organ versus finger.

An isolated data acquisition and processing system, comprising two identical channels has been developed to detect, process, record and display the red and infrared ac and dc PPG signals from the abdominal organs and the finger. All technical details of the processing system are described by Kyriacou et al. [5]. The output PPG signals from the processing systems are digitised using a 16-bit analogue-to-digital card (ADC) (National Instruments DAQ-Card-AI-16XE-50) and further analysed by a virtual instrument implemented in *Labview* on a laptop computer (*Dell Latitude Cpi D266XT*). PPG traces corresponding to infrared and red wavelengths from the abdominal organs, together with PPG traces from the identical finger probe, are obtained simultaneously and displayed on the laptop screen.

### 2.2. Patients and measurements

After obtaining approval from the Local Research Ethics Committee and informed, written consent, 12 adult patients undergoing elective surgery under general anaesthesia were studied. The seven women and five men ranged in age between 29 and 78 years, with an average age of  $52 \pm 4$  years. Table 1 summarises patients' details.

The study was observational and patients' surgical and anaesthetic management were as per routine. Induction with propofol (short-acting intravenous sedative agent

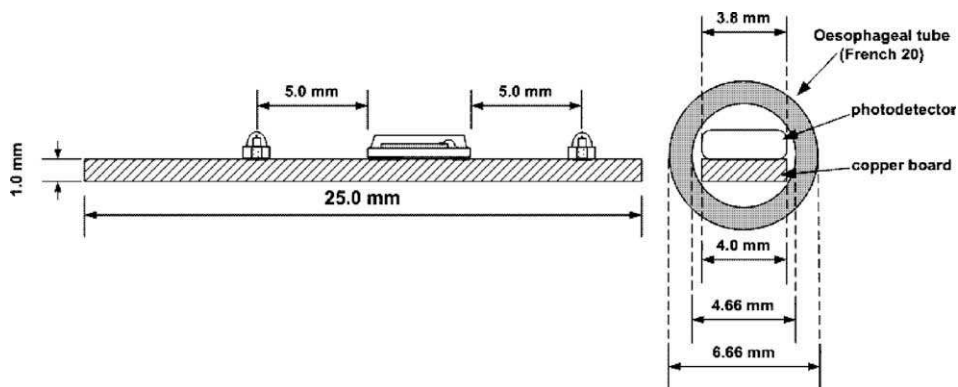

**Fig. 1.** Side and cross sectional view of the reflectance electro-optical abdominal organ PPG probe. In the cross sectional view the probe is shown inserted in the gastric tube.

**Table 1**

Details of the patients used for the abdominal PPG study.

Patients	Sex	Age	Surgical procedures
1	F	49	Anterior sphincteroplasty
2	F	29	Bowel resection
3	F	38	Colectomy with ileo-rectal anastomosis
4	F	57	Repair of incisional hernia
5	M	54	Pancreatico-duodenectomy and right adrenalectomy
6	F	47	Laparotomy
7	M	57	Whipples procedure
8	F	47	Biliary reconstruction, re-do choledochojejunostomy
9	M	31	Cystoscopy, urethric stenting, abdomino perineal excision of ileoanal pouch
10	M	78	Biliary bypass
11	M	62	Laparotomy, defunctioning colostomy
12	F	70	Laparotomy, defunctioning colostomy

used for the induction of general anaesthesia) 2–3 mg/kg and fentanyl (powerful opioid analgesic) 1–2 µg/kg was followed by atracurium (neuromuscular-blocking drug used adjunctively in anaesthesia to facilitate endotracheal intubation and to provide skeletal muscle relaxation during surgery) 0.5 mg/kg, tracheal intubation and intermittent positive pressure ventilation. Anaesthesia was maintained with inhalation method using 1–2% isoflurane and 50–70% nitrous oxide in oxygen. Patients received intravenous boluses of fentanyl, morphine and atracurium as clinically indicated. All patients were haemodynamically stable and well oxygenated.

The reflectance abdominal probe and the identical reflectance finger probe were used for the simultaneous recording of PPG signals from the abdominal viscera and from the finger. Both probes were connected to the *Processing system*. The *Virtual instrument* was used for the acquisi-

tion of the PPG signals. To facilitate comparison studies between red and infrared ac and dc PPG signals from the two channels (abdominal viscera and finger), the hardware and software gains of the *Processing system* and *Virtual instrument* were identical for both channels. A commercially available transmission type pulse oximeter probe was also used on an adjacent finger to record finger SpO<sub>2</sub>.

The abdominal PPG probe was inserted into a sealed, disposable size 20 French gauge gastric tube. Sealing of the sterile gastric tube, for prevention of contamination, was achieved aseptically by cutting off the blind tip and inserting it retrogradely into the distal lumen. The PPG probe, mounted on the end of a semi-rigid cable, was then passed down the gastric tube to its final position with the probe approximately 0.5 cm from the sealed end. After the abdomen was opened the gastric tube containing the probe was passed to the surgeon and it was applied gently to the surface of each abdominal organ so that the emitted light was reflected from its surfaces (Fig. 2). General theatre and operating lights were switched off. Simultaneous ac and dc PPG traces from each abdominal organ and the finger were recorded for approximately 2 min.

### 2.3. Data analysis and statistics

Data files recorded by the *LabVIEW Virtual instrument* software were analysed offline. Patients were only accepted into the final analysis if measurable visceral PPGs were present for at least one abdominal organ. The amplitudes of the visceral and finger ac PPG signals for each patient were measured on printouts from *LabVIEW* manually and the means and standard deviations ( $M \pm SD$ ) were calculated. The statistical significance of the mean difference between the PPG amplitudes at the investigated abdominal organs and the finger was assessed by performing a

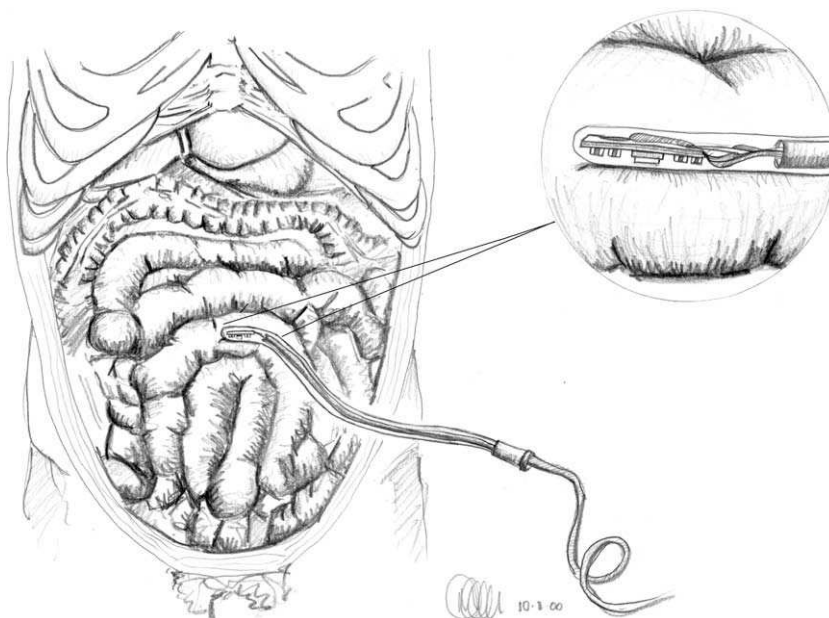

**Fig. 2.** Reflectance abdominal organ PPG probe placed on the surface of the human bowel.

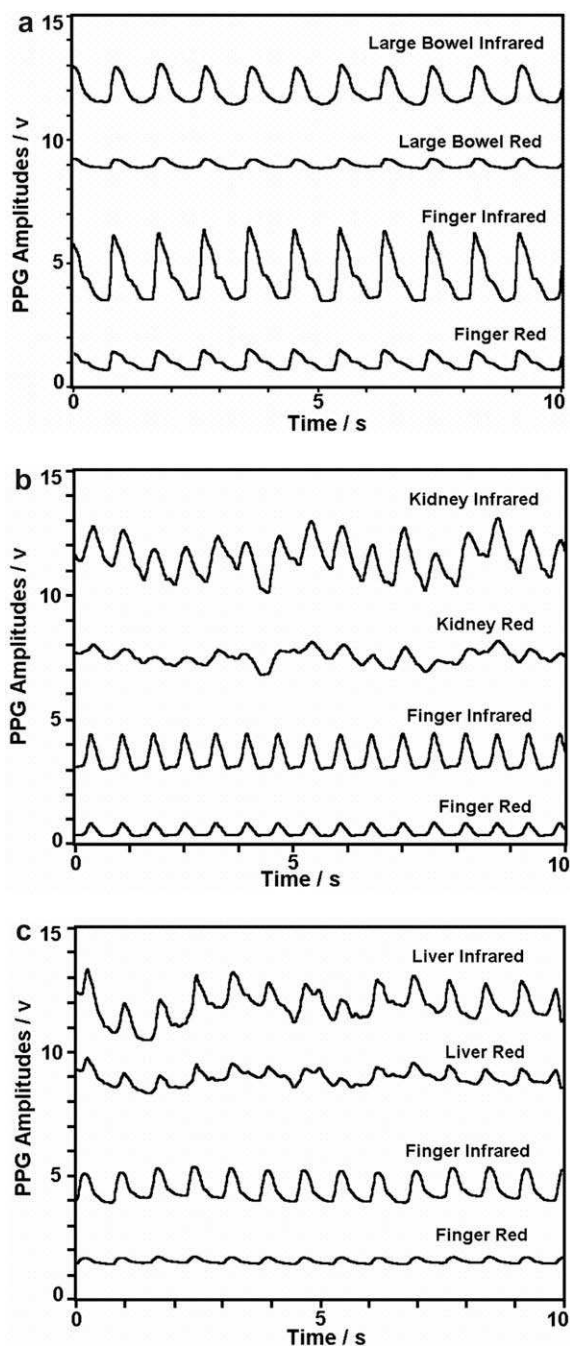

**Fig. 3.** (a) ac PPG traces from simultaneous measurements at the bowel and finger; (b) ac PPG traces from simultaneous measurements at abdominal organs (kidney and liver) and the finger.

**Table 2**

Mean ( $\pm$ SD) of ac peak-to-peak PPG amplitudes (V) at two wavelengths at the three abdominal organs and the finger.

	Mean ac PPG amplitudes (V)			
Investigated organ	Bowel (V)	Liver (V)	Kidney (V)	Finger (V)
Infrared IR(880 nm)	1.02 ( $\pm$ 0.38)	0.84 ( $\pm$ 0.31)	1.02 ( $\pm$ 0.62)	1.33 ( $\pm$ 0.73)
Red R(655 nm)	0.43 ( $\pm$ 0.18)	0.40 ( $\pm$ 0.10)	0.36 ( $\pm$ 0.16)	0.44 ( $\pm$ 0.23)
Number of patients (n)	12	8	6	11

One-Way Analysis of Variance (ANOVA) for both infrared and red wavelengths using *SigmaStat* (SPSS Ltd., Birmingham, UK). One-way ANOVA is used in this case to test for differences among the PPG measurements obtained from the four organs. The data were normally distributed, checked by performing the Kolmogorov-Smirnov normality (K-S) test. This K-S test is a goodness of fit test used to determine whether the underlying distribution of a single finite sample differs significantly from a normal distribution. A value of  $p < 0.05$  was considered statistically significant.

### 3. Results

Measurable PPG signals were obtained from the surface of the bowel in all 12 patients, and depending on intra-operative accessibility, also from the liver (8 patients) and the kidney (6 patients). Typical PPG traces obtained from the large bowel, kidney and liver, together with finger PPG traces at both wavelengths are shown in Fig. 3. The low frequency artefact present on the liver and kidney traces was due to movement of the handheld probe as these areas were more difficult to access resulting in less steady contact between the probe and organ.

Table 2 gives the mean  $\pm$  SD of the ac PPG amplitudes at both wavelengths at the three investigated abdominal organs and the finger. The PPG signals obtained from the abdominal organs and the finger had similar amplitudes and reasonably high signal-to-noise ratios. These results are also illustrated in Fig. 4.

The ANOVA test showed that there were no statistically significant differences between the PPG amplitudes recorded from the abdominal organs and those from the finger.

### 4. Discussion

Abdominal organ PPG signals at red and infrared wavelengths have been obtained with adequate signal-to-noise ratio from patients undergoing elective abdominal surgery under general anaesthesia. This appears to be the first quantitative report of PPG signals from human abdominal organs. The mean PPG amplitudes from both hollow and solid abdominal organs are not significantly different from those obtained simultaneously from a finger for both wavelengths, although there is considerable variability. The primary objective of this work was to measure the amplitude of PPG signals from various abdominal organs. However, some random comparisons of online estimation of  $SpO_2$  from the abdominal organs



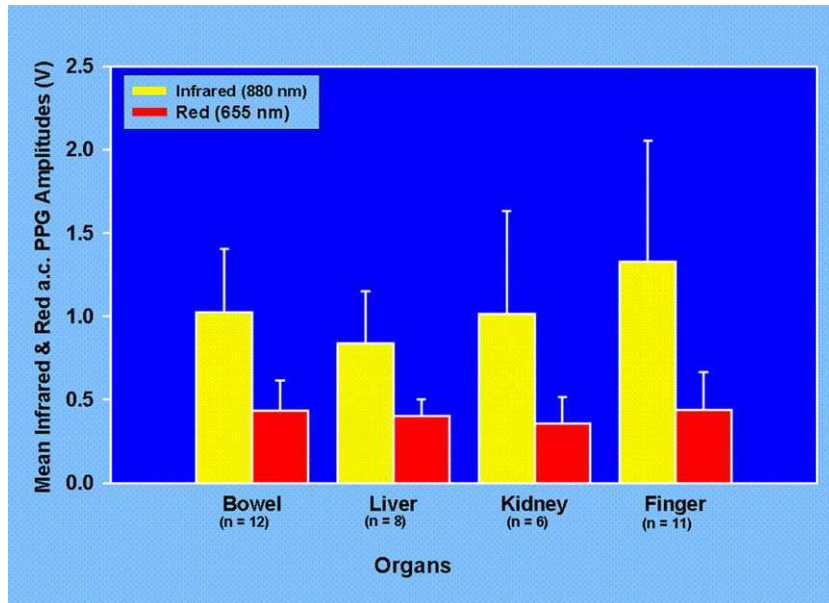

Fig. 4. ac Peak-to-Peak PPG Amplitudes, Mean ( $\pm$  SD), at two wavelengths from the three abdominal organs and the finger.

showed good agreement with SpO<sub>2</sub> values obtained simultaneously from the commercial finger pulse oximeter.

The developed probe is envisaged to be left in the abdomen, for post operative monitoring of blood oxygen saturation, where the surgeon will suture/secure the probe (located within a sterile transparent drainage tube) on the organ of interest and then pass the tube outside the abdomen where the probe will be connected to the processing system. The removable of the tube which contains the probe will be done in the same way as the surgeon usually removes a drainage tube.

## 5. Conclusion

Currently there is no available technique that can be used routinely for the assessment of abdominal blood oxygen saturation. In an attempt to develop a pulse oximeter for measuring blood oxygen saturation in the abdomen of critically ill patients this study describes an electro-optical probe for the investigation of photoplethysmographic signals from various abdominal organs during open laparotomy for the first time. The fact that satisfactory PPG signals could be acquired from all investigated abdominal organs supports the hypothesis that pulse oximetry can be used as a monitoring technique for abdominal organs such as the bowel, liver and kidney. Further work needs to be carried out to validate this hypothesis.

## Acknowledgements

We gratefully acknowledge the support of the Joint Research Board of St. Bartholomew's Hospital, and also Professor N. Williams for his clinical support for this study.

## References

- [1] A. Crerar-gilbert, P.A. Kyriacou, D.P. Jones, R.M. Langford, Assessment of photoplethysmographic signals for the determination of splanchnic oxygen saturation in humans, *Anaesthesia* 57 (5) (2002) 442–446.
- [2] J. Denobile, P. Guzzetta, K. Patterson, Pulse oximetry as a means of assessing bowel viability, *J. Surg. Res.* 48 (1990) 21–23.
- [3] J.J. Ferrara, D.L. Dyess, M. Lasecki, S. Kinsey, C. Donnell, G. Jurkovich, Surface oximetry. A new method to evaluate intestinal perfusion, *Am. Surg.* 54 (1988) 10–14.
- [4] P.A. Kyriacou, A.R. Moye, D.M.A. Choi, R.M. Langford, D.P. Jones, A system for investigating oesophageal photoplethysmographic signals in anaesthetised patients, *Med. Biol. Eng. Comput.* 37 (1999) 639–643.
- [5] P.A. Kyriacou, S. Powell, R.M. Langford, D.P. Jones, Esophageal pulse oximetry utilizing reflectance photoplethysmography, *IEEE Trans. Biomed. Eng.* 49 (11) (2002) 1360–1368.
- [6] F. Lemaire, G. Apolone, L. Blanch, J.Y. Fagon, P. Foex, G. Hedenstierna, D. Morel, P. Parsons, A. Pesenti, G. Ramsay, G. Simbruner, A.S. Slutsky, Tissue hypoxia. How to detect, how to correct, how to prevent?, *Intensive Care Med* 22 (1996) 1250–1257.
- [7] P.H. Macdonald, P.K. Dinda, I.T. Beck, C.D. Mercer, The use of oximetry in determining intestinal blood flow, *Surg. Gynecol. Obstet.* 176 (1993) 451–458.
- [8] K. Ouriel, W.M. Fiore, J.E. Geary, Detection of occult colonic ischaemia during aortic procedures: use of an intraoperative photoplethysmographic technique, *J. Vasc. Surg.* 7 (1988) 5–9.
- [9] W. Pearce, D. Jones, G. Warren, E. Bartle, T. Whitehill, R. Rutherford, The use of infrared photoplethysmography in identifying early intestinal ischaemia, *Arch. Surg.* 22 (1987) 308–310.
- [10] J.G. Webster, *Design of Pulse Oximeters*, Institute of Physics Publishing, Bristol, 1997.