

McGuinness-Abdollahi, Z., Thaha, M. A., Ramsanahie, A., Ahmed, S., Kyriacou, P. A. & Phillips, J. P. (2015). Intraoperative monitoring of intestinal viability: Evaluation of a new combined sensor. *Engineering in Medicine and Biology Society (EMBC), 2015 37th Annual International Conference of the IEEE, 2015*, pp. 5126-5129. doi: 10.1109/EMBC.2015.7319545



**CITY UNIVERSITY
LONDON**

[City Research Online](#)

Original citation: McGuinness-Abdollahi, Z., Thaha, M. A., Ramsanahie, A., Ahmed, S., Kyriacou, P. A. & Phillips, J. P. (2015). Intraoperative monitoring of intestinal viability: Evaluation of a new combined sensor. *Engineering in Medicine and Biology Society (EMBC), 2015 37th Annual International Conference of the IEEE, 2015*, pp. 5126-5129. doi: 10.1109/EMBC.2015.7319545

Permanent City Research Online URL: <http://openaccess.city.ac.uk/13279/>

Copyright & reuse

City University London has developed City Research Online so that its users may access the research outputs of City University London's staff. Copyright © and Moral Rights for this paper are retained by the individual author(s) and/ or other copyright holders. All material in City Research Online is checked for eligibility for copyright before being made available in the live archive. URLs from City Research Online may be freely distributed and linked to from other web pages.

Versions of research

The version in City Research Online may differ from the final published version. Users are advised to check the Permanent City Research Online URL above for the status of the paper.

Enquiries

If you have any enquiries about any aspect of City Research Online, or if you wish to make contact with the author(s) of this paper, please email the team at publications@city.ac.uk.

Intraoperative Monitoring of Intestinal Viability: Evaluation of a New Combined Sensor

Zahra Abdollahi*, Mohamed A. Thaha*, Anthony Ramsanahie, Shafi Ahmed, Panayiotis A. Kyriacou, *Senior Member, IEEE* and Justin P. Phillips, *Member, IEEE*

Abstract— A dual wavelength photoplethysmography (PPG) and laser Doppler flowmetry (LDF) sensor was developed to investigate the suitability of these techniques for monitoring bowel viability intraoperatively. Clinical measurements were obtained from thirty patients undergoing bowel surgery. Three measurements were performed at different stages of the operation. The amplitude of infrared PPG decreased from the baseline measurement to the pre-anastomosis measurement by 36% and LDF flux decreased by 21% for the same measurements. An increase of 33% in amplitude for infrared PPG was observed from the pre-anastomotic to post-anastomosis measurement; the equivalent increase was not seen for LDF flux. The results revealed that the sensor could potentially indicate changes in perfusion and blood flow at critical phases of surgery, thereby assisting in the early detection of inadequate blood supply in bowel tissue. The results also suggest that laser Doppler is more sensitive to movement artefact compared to PPG.

I. INTRODUCTION

Removal of segments of small and large bowel is one of the commonest surgical procedures performed worldwide. Bowel resection is undertaken for a variety of conditions and includes ischaemia, bleeding, strictures, and obstruction [1]. Colorectal cancer is the third commonest cancer in the western world [2], and when detected early is often cured with surgical removal of the cancer bearing bowel and the associated lymph glands. In advanced cases of colorectal cancer, surgery is still relevant to address a tumour, which is bleeding, or one that is causing obstruction [3].

The critical steps in any bowel resection surgery include freeing the segment of the bowel from the adjacent structures (mobilisation), sealing the blood vessels (artery and or vein) supplying the segment of the bowel (pedicle ligation), removal of the diseased segment with adequate margins (resection), and joining together the healthy cut ends (intestinal anastomosis) to give continuity [4]. Anastomotic leak is still a dreaded complication resulting from break down of the anastomosis resulting in spillage of fluids from inside the bowel lumen into the abdominal cavity and may

lead to serious life-threatening infection. Despite the developments in technology and surgical techniques, the mortality risk from an anastomotic leak remains significant at 10 – 15% [5]. Adequate perfusion at the resected ends of the bowel is key to a successful outcome in intestinal anastomosis. During surgery, the surgeon prior to constructing an anastomosis assesses the adequacy of perfusion at the cut ends by a series of steps. This includes observing the colour, temperature and movement of the bowel limbs, and blood flow at the small vessels near the cut edges. Such assessment is subjective and is limited by observer variability influenced by the experience of the surgeon and may be prone to errors in judgment.

Quantitative evaluation of intestinal viability through objective measurement has been attempted since 1976 [6]. In the hope of finding an ideal monitoring technique to assess intestinal viability, several techniques have been introduced like pulse oximetry, near infrared and visible spectrophotometry (NIRS & VLS), and laser Doppler flowmetry [7]. To date, however, no ideal monitoring method is available for day-to-day clinical use, indicating the need for continued investigation in this field.

Hence, in an attempt to address this clinical need, a new sensor with a combination of PPG and LDF was developed as an intra-operative monitoring tool to assess intestinal viability. This paper presents the design and development of the new sensor and also provides the results from the preliminary *in vivo* study evaluating its performance in patients undergoing bowel resection.

II. MATERIALS AND METHODS

A. PPG/LDF processing system

A PPG/LDF system was constructed to pre-process, record and display raw PPG and LDF signals from the bowel tissue surface on a laptop computer. The main parts of the system are: a combined probe, PPG instrumentation unit (PPG unit) and the laser Doppler flux monitor (LDF monitor). The PPG unit consists of a small box (30 x 28 x 9 cm) containing a power supply unit (two 12 V 2.2 Ah sealed lead-acid batteries), LED current sources and a custom-made signal processing circuit with the associated combined probe and a notebook computer (Fig. 1).

The PPG signals and the perfusion signal from the laser Doppler flowmeter were acquired and recorded using a 14-bit data acquisition card (USB6009, National Instruments, TX, USA) at a sampling frequency of 100 Hz. A LabVIEW (National Instruments Inc. Austin, TX, USA) virtual instrument (VI) was implemented to display the raw PPG and

Zahra McGuinness-Abdollahi, Panayiotis A. Kyriacou and Justin P. Phillips are with the School of Mathematics, Computer Science and Engineering, City University London, EC1V 0HB, UK.

Mohamed A. Thaha is with the Bart's and The London School of Medicine & Dentistry, Blizard Institute, Queen Mary University of London, London, UK and the Royal London Hospital, Bart's Health NHS Trust, London, UK.

Anthony Ramsanahie and Shafi Ahmed are with the Royal London Hospital, Bart's Health NHS Trust, London, UK

*ZM-A (e-mail: Zahra.Abdollahi.1@city.ac.uk) and MAT (e-mail: m.a.thaha@qmul.ac.uk) are joint first authors and contributed equally.

LDF signals on the notebook computer. A simplified block diagram of the processing system is shown in Fig. 2.

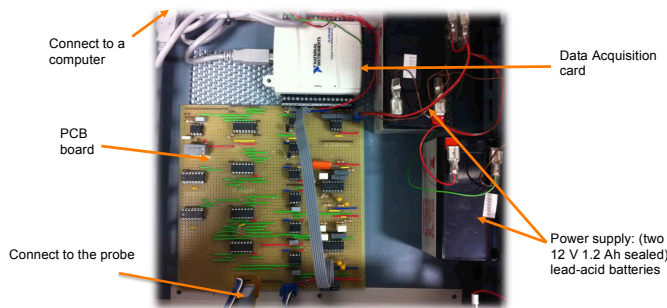

Figure 1. Instrumentation: unit containing Data acquisition card, PCB board, power supply unit and the connection to the computer and probe.

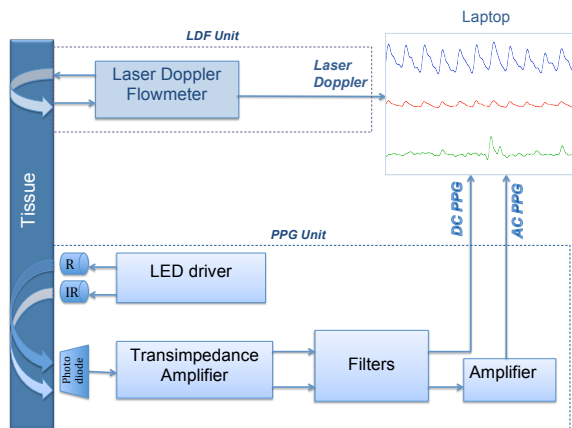

Figure 2. Basic block diagram of the PPG/LDF processing system.

B. Combined PPG/LDF probe

A combined PPG/LDF probe was constructed consisting of two main modules; a pulse oximeter reflectance sensor and a LDF fiber tip.

The reflectance sensor is a printed circuit board (PCB) measuring 32 (l) x 8 (w) x 1.5 (h) mm, consisting of a red and an infrared LEDs and a photodetector. Surface mounted ceramic type red LED and infrared LED were used with peak emission wavelength of 628 nm and 940 nm respectively. The detector used is a surface mounted silicon PIN photodiode, sensitive to light in the 400 nm to 1100 nm range with the radiant sensitive area of 7 mm². The separation distance from the center of the photodiode to the center of each LED was set to be 7 mm. A commercial titanium laser Doppler disc probe (Moor Instruments VP8C, Moor Instruments Ltd., UK) was also incorporated into the sensor at a distance of 7 mm from the center of the photodiode.

Fig. 3 shows a three-dimensional concept of the combined probe. Commercial software Altium Designer (Altium limited, Sydney, Australia) was used to design the sensor. The probe was designed to be small enough to allow introduction through a 10 - 12 mm laparoscopic trocar during the surgery.

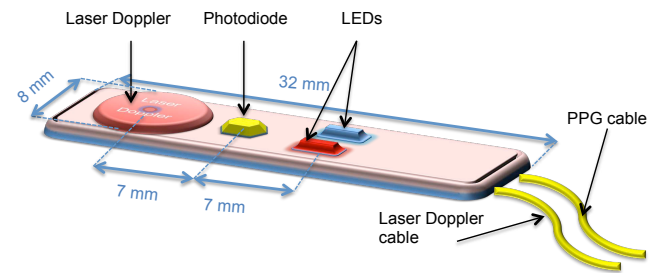

Figure 3. The three-dimensional concept of the combined probe.

C. Preliminary clinical evaluation

Clinical validation of the performance of the probe was undertaken in a prospective study involving thirty patients undergoing bowel resection. The inclusion criteria included (a) adult patients (age 17 – 95 years) undergoing planned bowel resection, (b) able to give informed consent, and (c) no previous major bowel resection. Emergency surgery was a specific exclusion criterion. The study commenced after obtaining ethical approval (National Research Ethics Service (NRES) Research Ethics Committee London: City & East). A standard protocol was followed for simultaneously recording the PPG and LDF signals for one minute by placing the probe on the outer surface of the bowel segment at three different phases of surgery: pre-mobilisation, pre-anastomosis after resection, and post-anastomosis. Care was taken to limit optical interference during measurement by turning off the theatre overhead lights and the laparoscopic light source. Despite all attempts to get all three measurements in each trial as planned, it wasn't possible in all subjects. This was mostly due to insufficient time to complete the measurements without unacceptably delaying the operation, failure to detect good quality PPG or LDF signals due to poor contact with the tissue surface, or other technical reason. The acquired signals were then compared for the differences in amplitude of PPG signals and the LDF flux at the three stages. The pre-mobilisation measurement was considered the baseline value for the purpose of the study.

Fig. 4 shows a picture of the PPG/LDF recording during surgery.

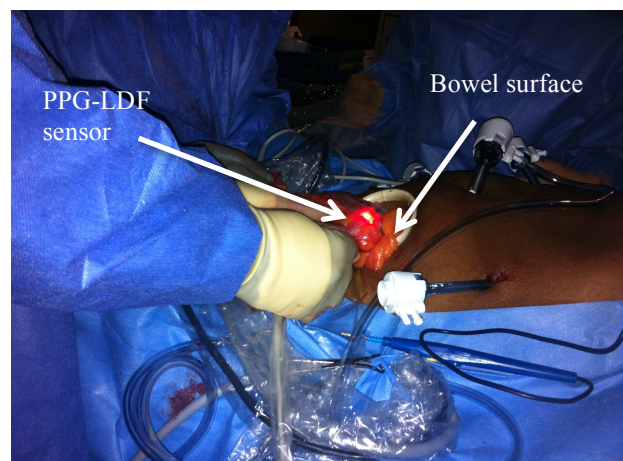

Figure 4. *In vivo* monitoring of bowel perfusion during operation. The surgeon is applying the sensor on the surface of the bowel just after preparing it for an anastomosis.

LabChart 7 software (ADInstruments) was used for the calculation of the average amplitude for AC PPG and LDF flux. 10-second periods of each measurement were selected for the data analysis (in some measurements the acquired data were excluded from the data analysis process due to insufficient duration of good quality signals mostly because of motion artefacts).

III. RESULTS

Good quality photoplethysmographic and laser Doppler signals were obtained from the combined probe in most cases. In the 30 patients (16M, 14F mean age (\pm SD) = 67 (\pm 15.5), age range 33 - 91), the total number of measurements in all investigated sites was 58; 17 pre-mobilisation, 19 pre-anastomosis and 22 post-anastomosis.

A. Pre-Mobilisation Measurements

Seventeen measurements were acquired before mobilisation and were considered ‘baseline’. The mean (\pm SD) IR and R AC amplitudes averaged for all subjects were 486 (\pm 301) mV and 409 (\pm 255) mV respectively, and the mean LDF flux averaged for all subjects was 62.4 (\pm 63.2) PU.

B. Pre and Post Anastomosis Measurements

A total of 63 pre and post anastomosis measurements were acquired. The mean IR AC in pre-anastomosis was 313 (\pm 155) mV, for R it was 333 (\pm 174) mV and for LDF it was 49.3 (\pm 48.1) PU. The mean IR AC amplitude at post-anastomosis for IR, R, and LDF was 416 (\pm 297) mV, 354 (\pm 204) mV and 45.6 (\pm 45.2) PU respectively. The amplitude of IR and R PPGs at post-anastomosis increased from pre-anastomosis.

Bar graphs of the mean (\pm SD) amplitude at all three measurements for R and IR respectively are shown in Fig. 5 and Fig. 6 for comparison. The mean (\pm SD) LDF flux was also obtained and the results are shown in a bar graph in Fig. 7.

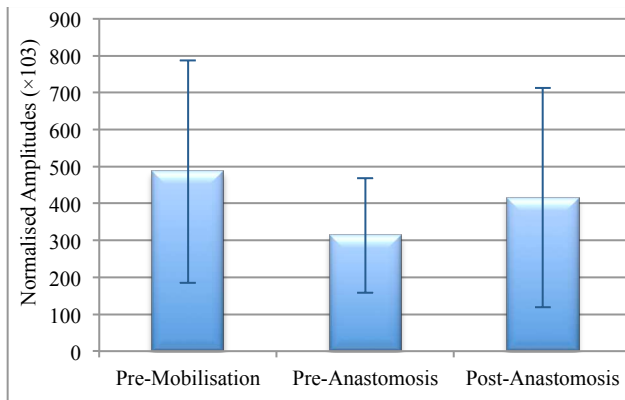

Figure 5. Mean (\pm SD) of normalised AC IR PPG amplitudes averaged for all patients at pre-mobilisation (n=14), pre-anastomosis (n=18) and post-anastomosis (n=16), (n: the actual number included in the data analysis).

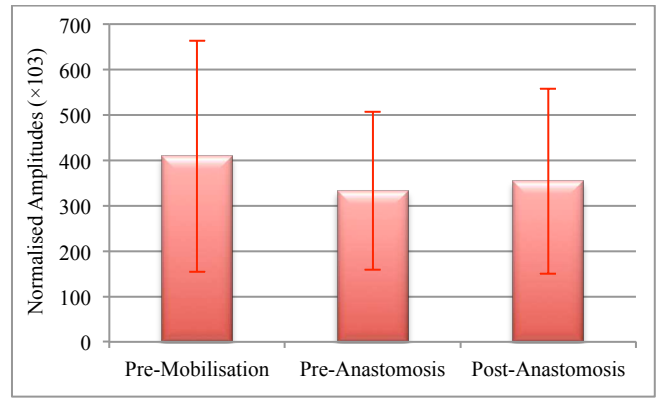

Figure 6. Mean (\pm SD) of normalised AC R PPG amplitudes averaged for all patients at pre-mobilisation (n=10), pre-anastomosis (n=11) and post-anastomosis (n=11), (n: the actual number included in the data analysis).

As seen in Fig. 7 the LDF flux decreases from pre-mobilisation to pre-anastomosis (62.4 PU to 49.3 PU). The LDF flux also slightly decreases from pre-anastomosis to post-anastomosis (49.3 PU to 45.6 PU).

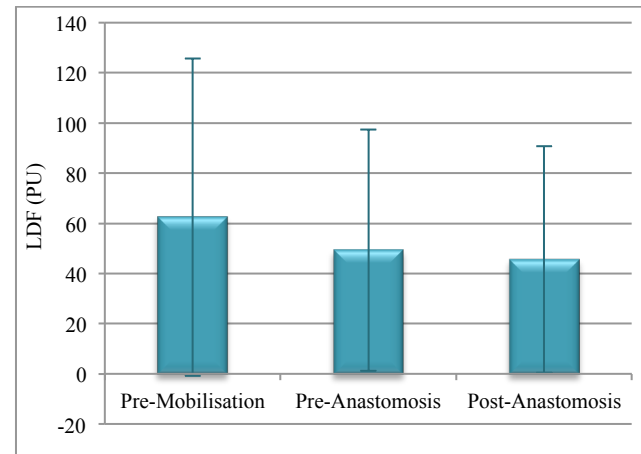

Figure 7. Mean (\pm SD) flux (PU) averaged for all patients at pre-mobilisation (n=13), pre-anastomosis (n=14) and post-anastomosis (n=17), (n: the actual number included in the data analysis).

IV. DISCUSSION AND CONCLUSIONS

Our preliminary results indicate that good quality PPG and LDF signals could be obtained in most cases from the external surface of the bowel during operation. In total, 58 measurements were obtained from all the different sites (17 pre-mobilisation, 19 pre-anastomosis, 22 post-anastomosis). The differences in AC PPG amplitude and also LDF flux acquired from different measurements were calculated. We observed wide standard deviations (\pm SD) across all the measurements (Fig. 5-7) mainly due to a large variability in PPG amplitudes and LDF flux for all patients. The large SD could be further explained due to differences in the density of blood vessels at the investigation site from one patient to another.

As expected, the PPG amplitude at pre-anastomosis decreased from the pre-mobilisation (baseline) value, reflecting one of the key surgical steps, i.e. clamping of the

main blood vessel to the segment of the bowel that was being resected. In the current study, no attempts were made to interpret the critical PPG values that are needed at the cut ends to ensure healthy bowel ends prior to anastomosis. However, the study did observe a positive change in the PPG amplitude at the bowel limbs before and after the anastomosis. This increase of 33% in amplitude for IR (313 mV to 416) and 6% for R (333 mV to 354) that was observed after anastomosis could indicate an improved blood volume and flow across the anastomosis once the restoration of bowel continuity is completed and the bowel returned to its normal anatomical position without any undue tension. This may indicate technical adequacy. Future studies should explore the magnitude of this change in a larger number of patients to allow correlating it with clinical outcomes after anastomosis. This objective measurement could then become a predictive variable that may guide timely intervention if an anastomotic leak is suspected.

The flux at pre-anastomosis decreased from pre-mobilisation by 20%, which was expected due to the reduction in blood flow to the bowel segment following vascular ligation. Although, the LDF flux before and after anastomosis changed slightly, this was not statistically significant. An expected increase in flux after anastomosis is not seen in the study possibly due to any changes being masked by motion artefacts, which LDF is highly sensitive to. Future studies are being planned to improve the ergonomics of the probe through design modifications to address this important technical issue.

In conclusion, we report the design and development of a novel dual PPG/LDF sensor to monitor intestinal viability during surgery. The exploratory pilot, feasibility clinical study on 30 patients undergoing bowel resection indicates that this system is capable of acquiring good quality PPGs and LDF signals intra-operatively. Further research is planned to re-design the probe to improve its ergonomics and efficiency. This will be followed by clinical validation in a larger group of patients with correlation to short and medium term clinical outcomes anticipating development of a novel sensor suitable for daily clinical use.

REFERENCES

- [1] R. G. Holzheimer and J. A. Mannick, (2001) *Surgical Treatment: Evidence-Based and Problem-Oriented*. Munich: Zuckschwerdt, Prt 3.
- [2] S. Doughan, V. Bennett, and F. Sagias, (2013) *A rare metastases of a colorectal primary to the clavicle*. Int J Surg Case Rep. 2013; 4(5): 470-472.
- [3] S. L. Wong, (2009) *Lymph Node Counts and Survival Rates After Resection for Colon and Rectal Cancer*. Gastrointest Cancer Res, 3(2 Suppl 1): S33-S35.
- [4] A. R. Adrouny, (2002) *Understanding Colon Cancer*. Univ. Press of Mississippi, Medical, Page 146.
- [5] S. D. Shah, C. A. Andersen, (1981) *Prediction of Small Bowel Viability Using Doppler Ultrasound*. Ann. Surg vol 194, no 1, 97-99.
- [6] L. Hulten, M. Jodal, J. Lindhagen, O. Lundgren, (1976) *Colonic blood flow in cat and man as analysed by an inert gas washout technique*. Gastroenterology. 70(1): 36-44.

- [7] L. Urbanavicius, P. Pattyn, D. V. de Putte, D. Venskutonis (2011) *How to assess intestinal viability during surgery: A review of techniques*. World J Gastrointest Surg 27; 3(5): 59-69