

Budidha, K. & Kyriacou, P. A. (2014). Investigation of Pulse Transit Times utilizing multisite reflectance photoplethysmography under conditions of artificially induced peripheral vasoconstriction. 2014 36th Annual International Conference of the IEEE Engineering in Medicine and Biology Society (EMBC), pp. 1965-1968. doi: 10.1109/EMBC.2014.6943998



**CITY UNIVERSITY
LONDON**

[City Research Online](#)

Original citation: Budidha, K. & Kyriacou, P. A. (2014). Investigation of Pulse Transit Times utilizing multisite reflectance photoplethysmography under conditions of artificially induced peripheral vasoconstriction. 2014 36th Annual International Conference of the IEEE Engineering in Medicine and Biology Society (EMBC), pp. 1965-1968. doi: 10.1109/EMBC.2014.6943998

Permanent City Research Online URL: <http://openaccess.city.ac.uk/11697/>

Copyright & reuse

City University London has developed City Research Online so that its users may access the research outputs of City University London's staff. Copyright © and Moral Rights for this paper are retained by the individual author(s) and/ or other copyright holders. All material in City Research Online is checked for eligibility for copyright before being made available in the live archive. URLs from City Research Online may be freely distributed and linked to from other web pages.

Versions of research

The version in City Research Online may differ from the final published version. Users are advised to check the Permanent City Research Online URL above for the status of the paper.

Enquiries

If you have any enquiries about any aspect of City Research Online, or if you wish to make contact with the author(s) of this paper, please email the team at publications@city.ac.uk.

Investigation of Pulse Transit Times utilizing multisite reflectance photoplethysmography under conditions of artificially induced peripheral vasoconstriction

K Budidha, *Member, IEEE*, and P A Kyriacou, *Senior Member*,

Abstract—Pulse Transit Time (PTT) is the time it takes for an arterial pulsation to travel from the heart to a peripheral site. In recent times, PTT has been advocated as a marker for assessing increased vascular resistance. However, the reliability of PTT as a marker for cardiovascular risks and its inverse relation to beat-to-beat blood pressure is still being investigated. In order to validate the technique as a reliable marker of vascular resistance, PTT measurements were made using photoplethysmographic (PPG) signals obtained from multiple measurement sites in 12 healthy volunteers undergoing right hand immersion in ice water for 30 secs. PTT measurements were made from the ear canal (EC), the left (LIF) and right index fingers (RIF) using custom made photoplethysmographic probes. Activation of the sympathetic nervous system during the ice water immersion caused an increase in vascular resistance, which is associated with an increase in mean arterial pressure and a decrease in PTT in all measurement sites. However, the change in PTT was much larger in the RIF when compared to the LIF and the EC. This demonstrates the cerebral flow auto-regulation and the profound peripheral vasoconstriction seen in the right hand. After the ice immersion period, the mean PTT measured from the EC returned to baseline, whereas the LIF PTTs exceeded baseline values. This is due to the local vasodilation resulted from the activation of a thermoregulatory mechanism.

I. INTRODUCTION

Heart attack and stroke are the two prominent causes of death worldwide, and are both a direct consequence of increased vascular resistance. In the UK alone there were almost 180,000 deaths from cardiovascular diseases in 2010, of which heart attack accounts to 55% of the deaths and stroke accounts to 27% [1]. In recent times, non-invasive measurement techniques such as Photoplethysmography (PPG) has been used to index these cardiovascular risks [2].

Photoplethysmography is an optoelectronic technique used to measure blood volume changes in the body by shining light into the vascular tissue, and measuring the changes in light absorbance produced during arterial pulsations. Several new methods using PPG have been previously described to assess cardiovascular risks such as, Heart Rate Variability (HRV) [3], Pulse Transit Time (PTT) [4], beat-by-beat pulse double normalized pulse volume analysis [5] and Pulse Wave Velocity (PWV) [6], etc. Of all the methods, PTT has

been advocated to be one of the more reliable markers for variations in cardiovascular related reactivity.

PTT is defined as the time it takes for pressure pulsations to travel from the left ventricle to a peripheral site. The velocity (PWV) of the pulse propagating through the arteries is given as the pulse propagation distance (PPD) divided by time.

$$PWV = \frac{PPD}{PTT} \quad (1)$$

An acute raise in the Blood Pressure (BP) causes vascular resistance to increase and hence the arterial walls become stiffer leading to an increase in the velocity of the pulse wave propagation. Conversely, as the BP decreases the vascular resistance decreases leading to drop in the PWV [7]. Therefore, the pulse transit time is indirectly proportional to the BP.

Although many studies have previously shown that PTT is capable of predicting changes in BP and vascular tone over a short period of time, its reliability as a marker for cardiovascular risks, its inverse relation to beat-to-beat blood pressure, and the accuracy of the methods used to calculate PTT are often questioned and are still being investigated [8], [9]. Also, the relative changes in PTTs measured from multiple sites simultaneously in response to a raise in BP has not been investigated previously. Such investigation would enable comprehensive understanding of auto regulation in the human body, and would help determine the relationships between PTT, heart rate, BP, and arterial resistance. This would also help validate PTT as a method for assessing cardiovascular risks.

In this context a study was carried out on 12 healthy volunteers undergoing a cold pressor test. The aim of the study was to monitor cardiovascular reactivity to an induced stress stimuli and the neutralizing auto-regulatory response, by measuring PPGs from centrally and peripherally perfused sites. Using the PPG signals and the R-wave of the ECG signal, the study aims to calculate PTTs from multiple sites and investigate the changes in PTTs measured during and after the cold pressor test. The three measurement locations are the ear canal (EC) which is centrally perfused [10], the right index finger (RIF) and the left index finger (LIF) which are peripherally perfused.

Manuscript received March 17, 2014.

K. Budidha is with the School of Engineering and Mathematical Sciences, City University London, London UK (✉karthik.budidha.l@city.ac.uk).

P. A. Kyriacou is with the School of Engineering and Mathematical Sciences, City University London, London UK (✉p.kyriacou@city.ac.uk)

II. METHODS AND MATERIALS

A. Measurement system

The measurement system was designed and developed to simultaneously detect, sample, record and display PPG, ECG and temperature signals. The block diagram of the entire measurement system is shown in Fig. 1.

The ear canal PPG probe is a headphone shaped PPG probe consisting of a micro optic reflectance sensor and the sensor casing [10]. The micro-optic reflectance sensor is a small Printed Circuit Board (PCB) consisting of an infrared surface mount Light Emitting Diode (LED) and a surface mount photodetector. The peak emission wavelength of the infrared LED is 870 nm . The photodetector used is a flattop photodiode with an active area of 0.65 mm^2 and peak sensitivity at 900 nm . The separation distance from the centre of the photodiode to the centre of each LED is 5 mm . The sensor casing was 3D printed using rigid opaque material (*Object VeroWhite plus rgd835*). Two reflectance finger PPG probes, optically identical to the ear canal probe were also developed to facilitate calculation of PTT from the left and right hand and also allow comparisons between PTTs calculated from the ear canal and the fingers. The finger probe was encapsulated with in a conventional pulse oximeter clip. To avoid direct contact between the optical components and the skin all the sensors were sealed using medical graded clear epoxy resin (*DYMAX 141-M, Dymax Corporation, Torrington, CT*). Fig. 2 shows all the three PPG sensors used in the experiment. Two thermistor based temperature sensors were used to monitor the temperature of the right and left hand during the study. The thermistor used was *TSD202A*, - fast response thermistors from *BIOPAC systems, Inc*. A lead I ECG amplifier was developed to monitor the R waves of the QRS complex of the ECG signal, which was used as a timing reference for the PPG signals obtained from the fingers and the ear canal.

The main instrumentation unit comprises of emitter driver circuits, amplifiers, and filters for conditioning the detected signals prior to analogue-to-digital conversion and sampling. The instrumentation is powered by two 9V PP3 Nimh rechargeable batteries (*Digimax*). A 16-bit data acquisition card (*DAQpad-6211, National instruments corporation, Austin, Texas*) was used to digitise the PPG, ECG and

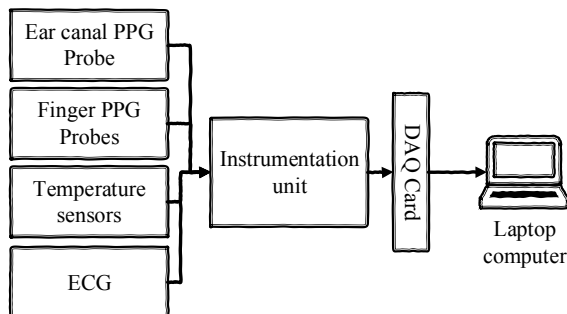

Fig. 1: Block diagram of the measurement system.

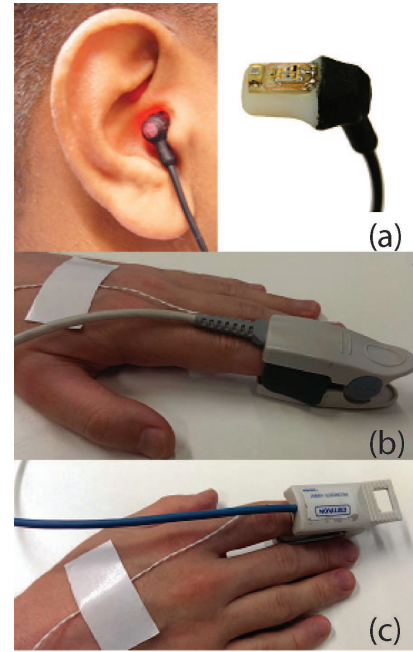

Fig. 2: (a) The ear canal PPG probe, (b) the left index finger PPG probe and (c) the right index finger PPG probe.

the temperature signals acquired from the instrumentation unit. A virtual instrument (VI) system is implemented on LabVIEW (*National Instruments Inc. Austin, TX, USA*) on a personal computer for data acquisition and real time display of the PPG, ECG and temperature signals.

B. Subjects

A cold pressor study was carried out on 12 healthy volunteers, 4 – ♂, 8 – ♀, aged between 18-36 (*mean age SD: 26.2 4.8 years*) with the approval of City University London Senate Research Ethics Committee. Volunteers with any history of cardiovascular diseases were excluded from the study. The experimental protocol was clearly explained to all the participants and a written consent was obtained from all the participants prior to the experiment. The subjects were asked not to smoke and exercise for at least two hours before the experiment.

C. Experimental protocol

The experiments were carried out in the Biomedical Engineering Research laboratory, School of Engineering and Mathematical Sciences, City University London under room temperatures between $22 \pm 2^\circ\text{C}$. Upon arrival, all the volunteers were asked to rest for 10 min to acclimatize, during which the informed consent was obtained. During the study, all the subjects were made to sit in a comfortable chair, with both hands resting on soft cushions, arranged to a height equivalent to their heart position. Once the volunteer was comfortable in the position, the finger PPG probes were attached to the index fingers of right and left hands, the ear canal probe was placed 9 mm deep in to the auditory canal, two thermistors were attached to the index fingers of

the right and left hands and a three lead ECG cable was connected to the Ag-AgCl ECG electrodes (*SKINTACT, F-WA00*) placed on the right arm, left arm, and left leg. Once all the sensors were in place, baseline readings were obtained from all the volunteers for at least 2 *min* before they were notified with a countdown (3 →) to slowly start immersing their right hand into the ice bath maintained at approximately 1°C. After 30 *sec* into the ice bath, the volunteer was once again notified to slowly remove their right hand out of the ice bath and place it back on the surface. Monitoring was continued until the skin temperature of the right hand of the volunteer has reached to at least 22°C.

D. Data analysis

The recorded PPG, ECG and temperature signals were extracted separately for analysis in MATLAB (*The Math Works Inc.*). The PPG and ECG signals were preprocessed to remove noise. The PPG signals were filtered using an equiripple band-pass filter with cut-off frequencies 0.4Hz and 10Hz. The ECG signal was filtered using an equiripple low pass filter with a cut-off frequency of 40Hz. The mean amplitude of the AC infrared PPG signals acquired from the EC, the RIF and the LIF and the change in temperature of both hands were compared.

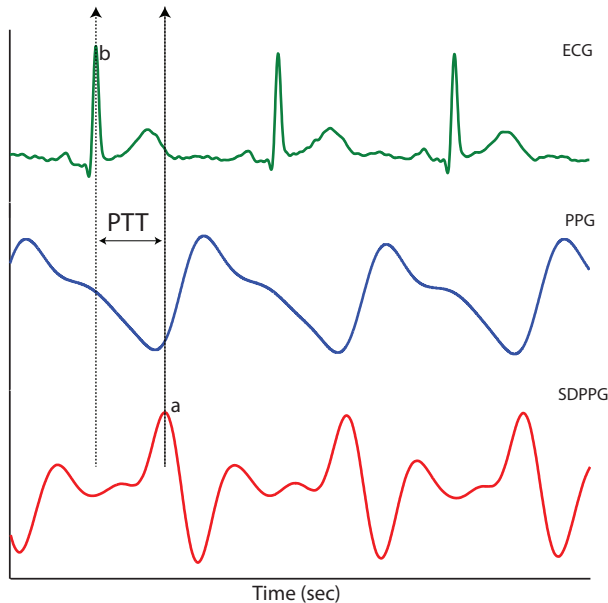

Fig. 3: Shows the ECG, PPG and second derivate photoplethysmographic signal (SDPPG) signals. PTT is the time difference between points 'a' and 'b'.

The R-wave peak of the ECG signal was extracted for the entire signal to calculate PTT. PTT was calculated by using the foot of the PPG and the R-wave peak of the ECG signal. To increase accuracy and the detection rate of the inflection points and to make the interpretation easier, the second derivative analysis was performed on all the PPG signals using the SavitzkyGolay method, with a window

width of 51 points. The first peak of the second derivate photoplethysmographic signal (SDPPG) represents the foot of the PPG. By finding the time difference between the R wave peak of the ECG signal and the peak of the SDPPG, PTT was calculated (Fig. 3). Using the SDPPG signals from the EC, the LIF, and the RIF, mean PTTs were calculated for all three stages of the experiment (before, during and after the ice immersion) for each volunteer.

III. RESULTS

The infrared AC PPG signals acquired from the EC, the RIF and the LIF, and the simultaneously acquired temperature signals from both right and left index fingers of a randomly selected volunteer are shown in Fig. 4. Once the right hand was immersed into the ice bath, the amplitude of the PPG signals acquired from the RIF have significantly reduced. This is expected due to the profound vasoconstriction resulting from the drop in temperature of right hand.

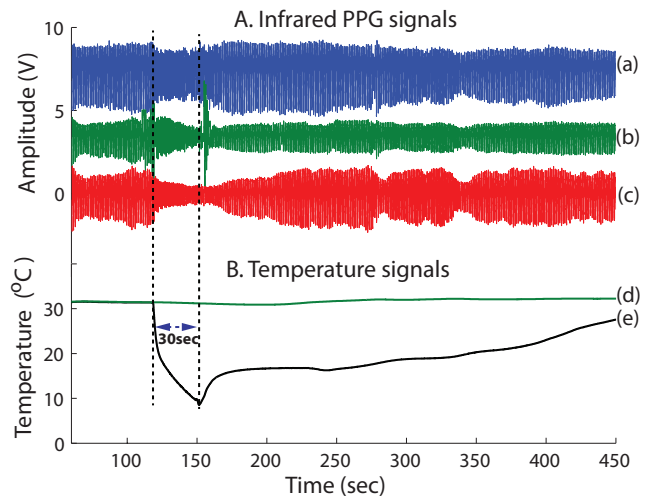

Fig. 4: A. Infrared AC PPG signals recorded from (a) the ear canal, (b) the right index finger and (c) the left index finger of a volunteer. B. Simultaneously obtained temperature reading from (d) the left index finger and (e) the right index finger of the same volunteer for a period of 6 min.

However, a significant drop in the amplitude of the PPG signals obtained from the LIF were also observed, although the temperature of left hand remained relatively constant throughout the experiment. On the contrary, no significant changes were observed in the amplitude of the PPG signals

TABLE I: Changes in PTT (\pm SD) calculated from all three locations during all three phases of the experiment

Location	Before immersion	During immersion	After immersion
EC	134.06 \pm 25.9 ms	123.82 \pm 23.4 ms	134.34 \pm 32.1 ms
RIF	195.86 \pm 26.3 ms	164.61 \pm 41.9 ms	187.37 \pm 40.5 ms
LIF	207.65 \pm 30.3 ms	184.95 \pm 34.4 ms	234.16 \pm 38.7 ms

acquired from the EC. This demonstrates the differences in peripheral and cerebral flow auto-regulation.

The mean PTT values calculated using the PPG signals acquired from ear canal, left index finger and right index finger during all three stages of the experiments are shown in Table. I. Also, the data is graphically displayed with the use of Box and Whiskers plot in Fig. 5. During the ice water immersion, the sudden change in temperature forces the thermoregulatory center to stimulate the sympathetic nervous system, in order to maintain homeostasis. This leads to an increase in vascular resistance of peripheral blood vessels. This in turn causes the blood pressure and heart rate to increase, and hence a drop in PTT. Similar effect was observed in all the volunteers participating in this study.

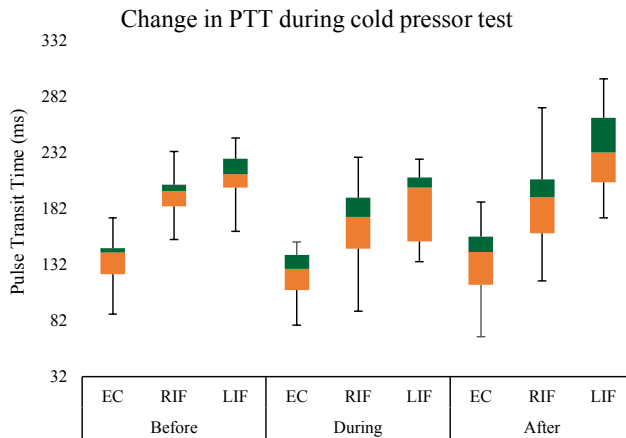

Fig. 5: Box and Whiskers plot demonstrating the change in PTT measured from three different location during the cold pressor test.

As soon as the right had was immersed into the ice water, the PTT values dropped across all measurement locations. However, the percentage drop in mean PTT measured from the RIF was higher than the LIF and the EC. PTTs measured from the RIF have dropped by 16%, whereas the PTT measured from the LIF and the EC have dropped by 11% and 8% respectively. After the ice immersion period, the mean PTT measured from the EC and the RIF returned to baseline, whereas the LIF PTT exceeded baseline values. This is due to the local vasodilation resulted from the activation of a thermoregulation mechanism. This demonstrates that the cerebral flow is much more resistant to quick changes in BP compared to peripheral blood flow.

IV. CONCLUSION

From these observations, it is suggested that PTT measurements made using PPGs from different locations can be used as an effective parameter for estimating local vascular resistance and hence as a potential diagnostic tool for cardiovascular diseases.

REFERENCES

[1] N. Townsend, K. Wickramasinghe, and P. Bhatnagar, *Coronary Heart Disease Statistics 2012*, 1st ed. British Heart Foundation.

[2] M. F. O'Rourke, A. Pauca, and X.-J. Jiang, "Pulse wave analysis," vol. 51, no. 6, pp. 507–522.

[3] K. Shafqat, S. K. Pal, S. Kumari, and P. A. Kyriacou, "Changes in heart rate variability in patients under local anesthesia," vol. 2007, pp. 299–302.

[4] L. A. Geddes, M. H. Voelz, C. F. Babbs, J. D. Bourland, and W. A. Tacker, "Pulse transit time as an indicator of arterial blood pressure," vol. 18, no. 1, p. 7174.

[5] G. Tanaka, Y. Sawada, and K.-i. Yamakoshi, "Beat-by-beat double-normalized pulse volume derived photoplethysmographically as a new quantitative index of finger vascular tone in humans," vol. 81, no. 1, pp. 148–154.

[6] A. T. R. Devin B McCombie, "Adaptive blood pressure estimation from wearable PPG sensors using peripheral artery pulse wave velocity measurements and multi-channel blind identification of local arterial dynamics," vol. 1, pp. 3521–4.

[7] R. Smith, J. Argod, J. Pepin, and P. Levy, "Pulse transit time: an appraisal of potential clinical applications," vol. 54, no. 5, pp. 452–457.

[8] J. Proena, J. Muehlsteff, X. Aubert, and P. Carvalho, "Is pulse transit time a good indicator of blood pressure changes during short physical exercise in a young population?" vol. 2010, pp. 598–601.

[9] H. Gesche, D. Grosskurth, G. Kchler, and A. Patzak, "Continuous blood pressure measurement by using the pulse transit time: comparison to a cuff- based method," vol. 112, no. 1, pp. 309–315.

[10] K. Budidha and P. A. Kyriacou, "The human ear canal: investigation of its suitability for monitoring photoplethysmographs and arterial oxygen saturation," vol. 35, no. 2, pp. 111–128.